

Parts Catalog



PF16E

Electric Fryer

Model: PF16E

5/5/2023 Rev B

IMPORTANT!

TO EXPEDITE SHIPMENT OF PARTS, ALWAYS SPECIFY MODEL, REV,
PART NUMBER, AND SERIAL NUMBER OF UNIT.

GLOBE FOOD EQUIPMENT COMPANY

2215 East River Road
Dayton, Ohio 45439

Parts Department

Toll Free 1-800-745-6238 · Fax (937) 290-0585

E-Mail: info@globefoodequip.com

Website: www.globefoodequip.com

Not for resale

Table of Contents

Description

Page

PF16E Electric Fryer

4

PF16E Wiring Diagram

6



PF16E Electric Fryer

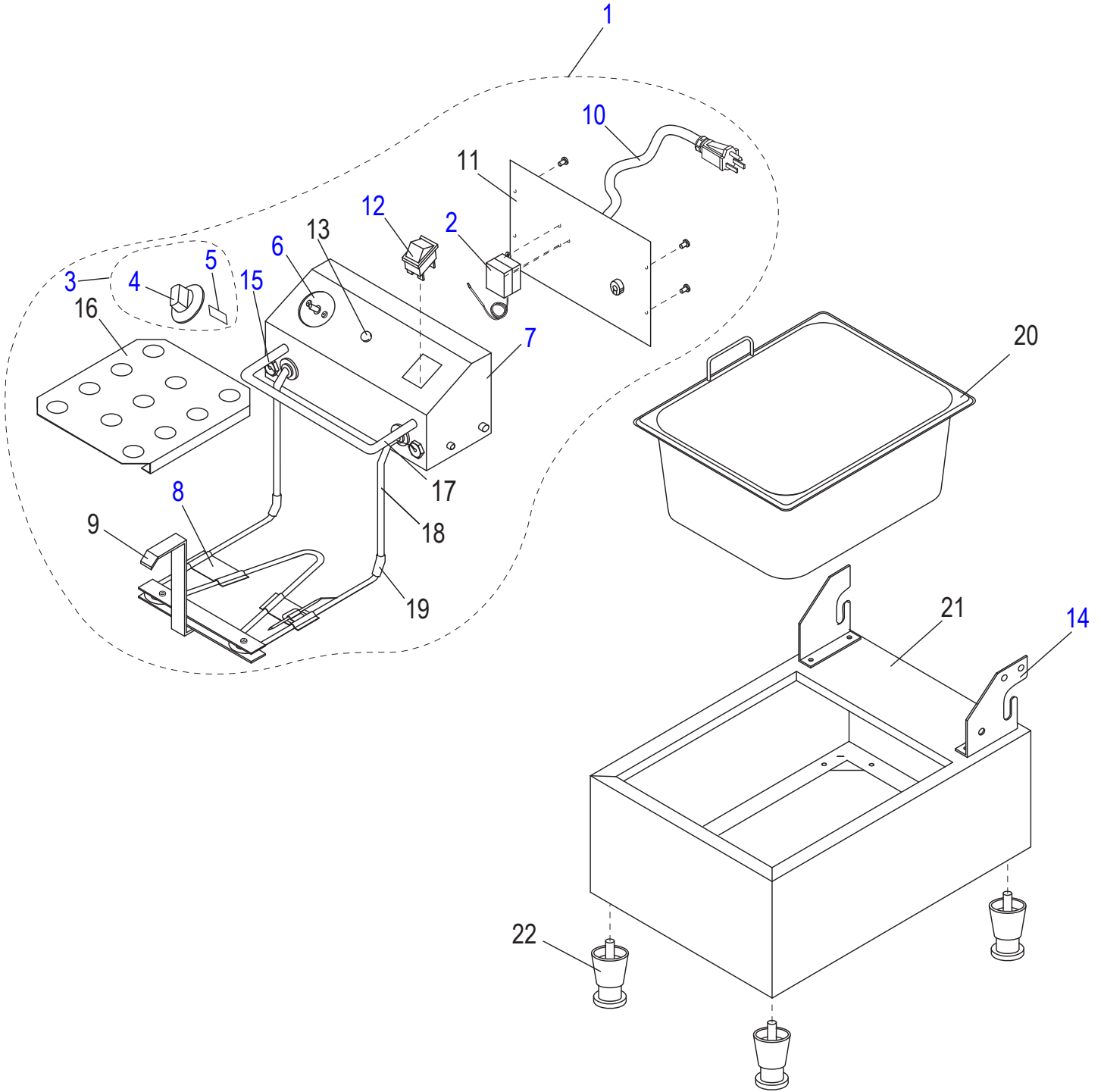



PF16E Electric Fryer

Item	Part Number	Description	Qty	Serial Number
1	U06051471101	Control Box Assembly (Front Hook)	1	PF16E0001111 ->
2	U00577	Thermal Reset	1	
3	U01033	Knob Kit	1	
4		Dial	1	
5		Spring Plate	1	
6	U03051220008	Thermostat	1	
7		Control Enclosure	1	
8	U01051025402	Tube Clamp (Right)	2	
8	U00766	Tube Clamp (Left)	1	
9	U00584	Element Handle	1	
10	U03021205013	Power Cord (240V)	1	
11		Back Cover Plate	1	
12	U03041215027	Power Switch	1	
13	U03091240006	Indicator Light	1	
14	U01051025556	Flange Assembly (Left)	1	
14	U00765	Flange Assembly (Right)	1	
15	U02121165001	Stuffing Nut	2	
16	U01051025555	Element Cover	1	
17		Basket Hook	1	
18	U03061225047	Heating Element	1	
19	U01051025128	Wire Clamp	2	
20	U01121063044	Pan (Retractable Handles)	1	Used w/Front Hook Baskets
21		Fryer Cabinet	1	
22	U01021005002	Foot	4	
23	U02053	Overlay	1	(Not Shown)
24	U02043	Wire Harness	1	(Not Shown)
25	U00579	Strain Relief	1	(Not Shown)



PF16E Wiring Diagram

