

# Parts Catalog



**GSP30B**

## Label Printing Scale

**Model: GSP30B**

03/22/2019 Rev. B

IMPORTANT!

TO EXPEDITE SHIPMENT OF PARTS, ALWAYS SPECIFY MODEL, REV,  
PART NUMBER, AND SERIAL NUMBER OF UNIT.

## **GLOBE FOOD EQUIPMENT COMPANY**

2215 East River Road

Dayton, Ohio 45439

### **Parts Department**

Toll Free 1-800-745-6238 · Fax (937) 290-0585

E-Mail: [info@globefoodequip.com](mailto:info@globefoodequip.com)

Website: [www.globefoodequip.com](http://www.globefoodequip.com)

Not for resale



# Table of Contents

**Description**

**Page**

GSP30B Scale Assembly

3

GSP30B Thermal Print Head Assembly

5

GSP30B Wiring Diagram

9



# GSP30B Scale Assembly

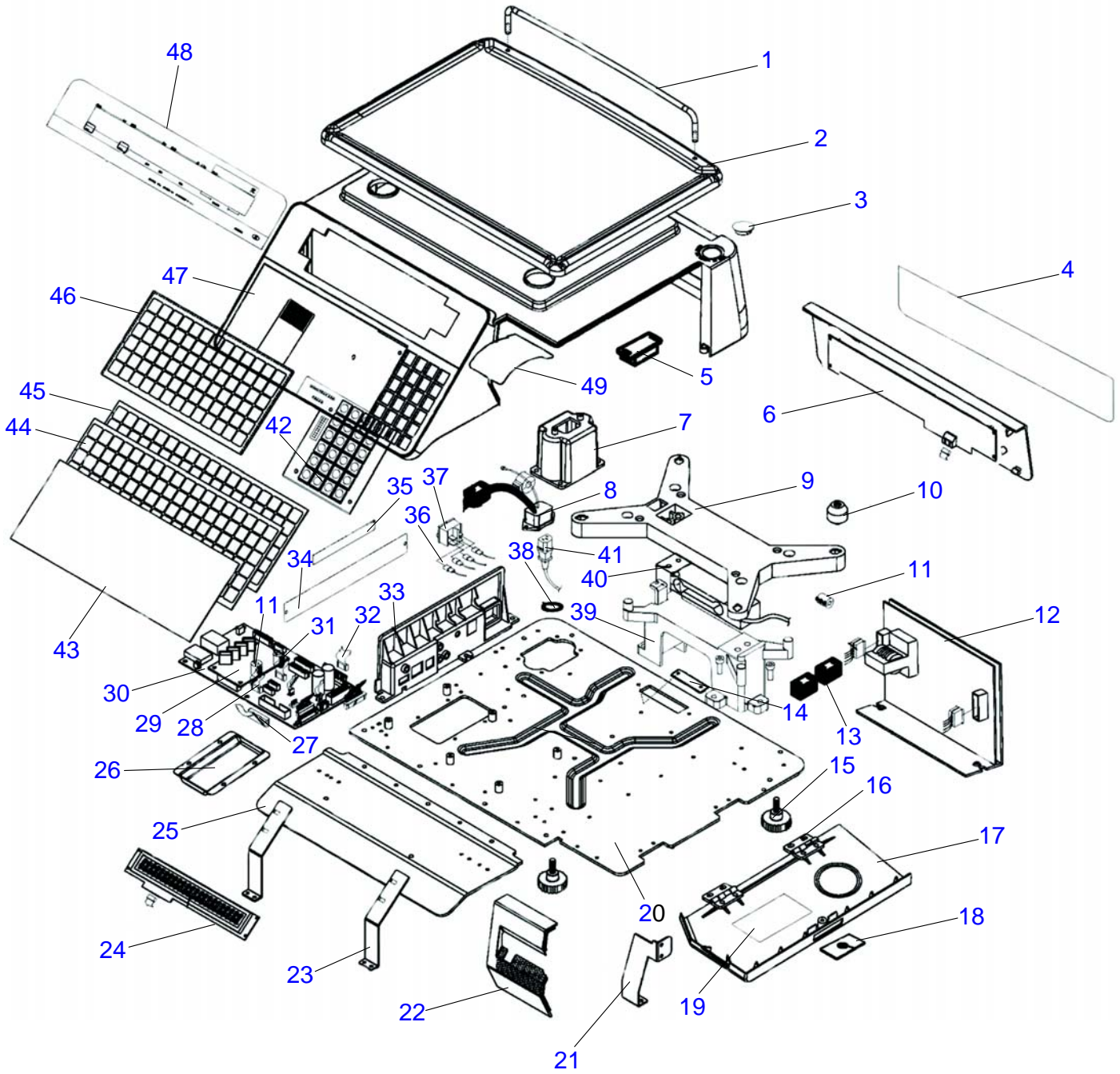



## GSP30B Scale Assembly

Item	Part Number	Description	Qty	Serial Number
1		Platter Guard	1	
2	E00830	Platter	1	
3		Level Bubble Decal	1	
4		Display Sheet	1	
5		Magnet	1	
6		Customer Display	1	
7		Power Outlet Support	1	
8		C4 Power Harness	1	
9		Support Plate	1	
10	E00918	Rubber Platter Support	4	
11		Ferrite Core	3	
12		Power Supply	1	
13		Ferrite Core	1	
14		Base Cover Bracket	1	
15	E00919	Adjustable Foot	4	
16		Hinge	2	
17		Printer Side Cover	1	
18		Magnet Bracket	1	
19		Printer Decal	1	
20		Base Plate	1	
21		Print Bracket	1	
22		Printer Front Cover	1	
23		Front Display Bracket	2	
24		LCD Display	2	
25		Front Display Base	1	
26		Access Cover	1	
27		S2 Keyboard Harness	1	
28		S2 Display Harness	1	
29		A+D Power Board	1	
30		Main Power Board	1	
31		C3 Display Harness	1	
32		S2 Power Harness	1	
33		Connector Bracket	1	
34		Data Plate	1	
35		UNI-3 Sheet	1	
36		C3 Power Harness	1	
37	E00839	Power Switch	1	
38		Ground Cord Label	1	
39		Load Cell Bracket	1	
40		Load Cell Assembly	1	
41	E00920	Power Cord	1	
42		Numeric Board	1	
43	E00825	Keyboard Cover	1	
44	E00826	Overlay (w/Blank Keys)	1	
45	E01049	Keyboard Sheet	1	
46	E00827	Keypad Membrane	1	
47		Upper Cover	1	
48		Operator Display Sheet	1	
49		Thermal Protector Sheet	1	
50	E01795	Fuse	1	(Not Shown)



# GSP30B Thermal Print Head Assembly

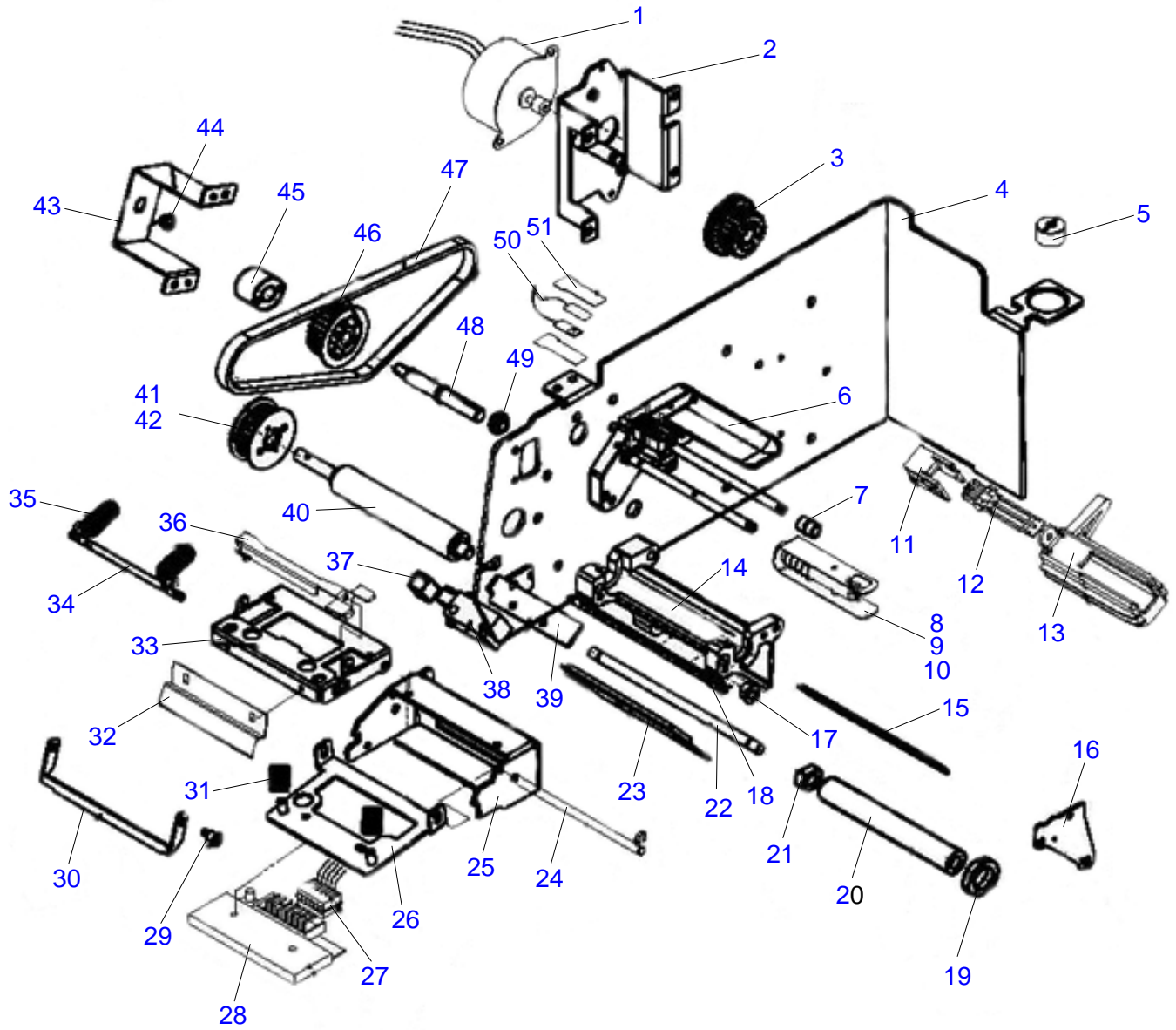



## GSP30B Thermal Print Head Assembly

Item	Part Number	Description	Qty	Serial Number
1		Stepper Motor	1	
2		Motor Bracket	1	
3		Stepper Motor Dual Gear	1	
4		Printer Frame	1	
5		Level Bubble	1	
6	E00869	Label Support	1	
7	E00870	Axle Bush	16	
8		Bobbin Bracket	1	
9		Bobbin Spring	1	
10		Bobbin Shaft	1	
11	E89283001	Label Guide Holder	1	
12	E89285804	Label Guide Lever	1	
13	E00914	Label Holder	1	
14		Label Guide	1	
15		Fixed Bracket	1	
16		Label Guide Cover	1	
17		Left Bushing	2	
18		Axis (02)	1	
19		Label Guide	1	
20		POM Shaft	1	
21		Bushing	1	
22		Axis (01)	1	
23		Peel Off Bracket	1	
24		Shaft 1	1	
25		Print Head Frame	1	
26		Print Head Bracket	1	
27		S2 Thermal Head Print Harness	1	
28	E00879	Thermal Print Head Assembly	1	
29		Cutter Screw	2	
30		Cutter Bracket	1	
31		Print Head Bracket Tension Spring	2	
32		Label Tear Bar	1	
33		Print Head Lock Bracket	1	
34		Print Head Hold Axis	1	
35		Spring Coil	2	
36		Print Head Push Bracket	1	
37		Peel Sensor Harness	1	
38		Reflector Photo Interrupter	1	
39		Peel Sensor Bracket	1	
40		Rubber Roller	1	
41		Drive Gear	1	
42		Drive Gear Cover	1	
43		Timing Belt Bracket	1	
44		Belt Bushing	1	
45		Gear Bushing	1	
46		Timing Belt Rewind Gear	1	
47		Timing Belt	1	
48		Timing Belt Rewind Axis	1	
49		Belt Bushing	1	
50	E00886	Label Sensor Assembly	1	(Incl. E00911, E00912, E00913)
50		Harness, Label Sensor C5	1	
50		LED	1	
50		Photo TR	1	



## **GSP30B Thermal Print Head Assembly**

---

Item	Part Number	Description	Qty	Serial Number
51	E00883	Sensor Bracket	2	



*INTENTIONALLY LEFT BLANK PAGE*



# GSP30B Wiring Diagram

