

# Parts Catalog



**GSGDUE14D**

## **Electric Sandwich Grills**

**Model: GSGDUE14D**

5/5/2023 Rev C

IMPORTANT!

TO EXPEDITE SHIPMENT OF PARTS, ALWAYS SPECIFY MODEL, REV,  
PART NUMBER, AND SERIAL NUMBER OF UNIT.

## **GLOBE FOOD EQUIPMENT COMPANY**

2215 East River Road  
Dayton, Ohio 45439

### **Parts Department**

Toll Free 1-800-745-6238 · Fax (937) 290-0585

E-Mail: [info@globefoodequip.com](mailto:info@globefoodequip.com)

Website: [www.globefoodequip.com](http://www.globefoodequip.com)

Not for resale



# Table of Contents

**Description**

**Page**

GSGDUE14D 14 Inch Double Grill Components (Smooth)

4

GSGDUE14D Wiring Diagram

6



# GSGDUE14D 14 Inch Double Grill Components (Smooth)

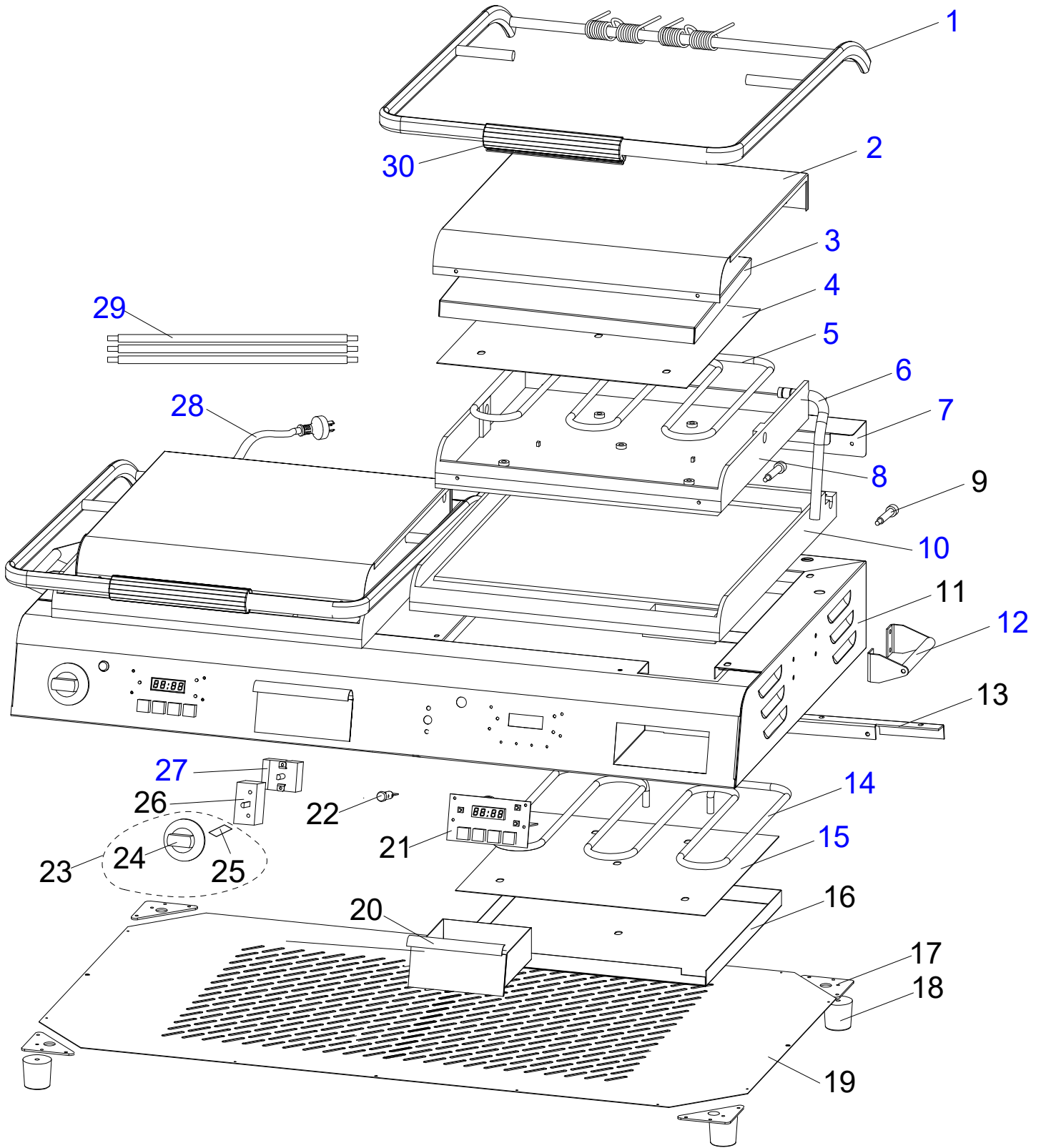



## GSGDUE14D 14 Inch Double Grill Components (Smooth)

| Item | Part Number  | Description                | Qty | Serial Number       |
|------|--------------|----------------------------|-----|---------------------|
| 1    | U00681       | Handle Assembly            | 2   |                     |
| 2    | U00682       | Top Cover                  | 2   |                     |
| 3    | U01071040244 | Upper Insulating Plate     | 2   |                     |
| 4    | U00684       | Upper Press Plate          | 2   |                     |
| 5    | U03061225116 | Upper Element              | 2   |                     |
| 6    | U00701       | Left Wiring Cover          | 1   |                     |
| 6    | U01021005045 | Right Wiring Cover         | 1   |                     |
| 7    | U00685       | Back Baffle                | 2   |                     |
| 8    | U00687       | Upper Left Plate (Smooth)  | 1   |                     |
| 8    | U00688       | Upper Right Plate (Smooth) | 1   |                     |
| 9    | U00690       | Adjust Nut                 | 4   |                     |
| 10   | U00692       | Lower Plate (Smooth)       | 2   |                     |
| 11   | U00693       | Body Assembly              | 1   |                     |
| 12   | U00694       | Side Handle Kit            | 2   |                     |
| 13   | U00695       | Adjustment Plate           | 2   |                     |
| 14   | U03061225117 | Lower Element              | 2   |                     |
| 15   | U00696       | Lower Press Plate          | 2   |                     |
| 16   | U00697       | Lower Insulating Plate     | 2   |                     |
| 17   | U00519       | Triangle Plate             | 4   |                     |
| 18   | U02121165003 | Foot Kit                   | 4   |                     |
| 19   | U00698       | Bottom Cover               | 1   |                     |
| 20   | U06051471181 | Drip Tray                  | 2   |                     |
| 21   | U01781       | Timer Assembly (220V)      | 2   |                     |
| 22   | U03091240006 | Indicator Light            | 2   |                     |
| 23   | U01033       | Knob Kit                   | 2   | (Incl. items 24-25) |
| 24   |              | Dial                       | 2   |                     |
| 25   |              | Spring Plate               | 2   |                     |
| 26   | U03041215033 | ON/OFF Switch              | 2   |                     |
| 27   | U03051220022 | Thermostat                 | 2   |                     |
| 28   | U00699       | Powercord (220V)           | 1   |                     |
| 29   | U00700       | Wire Harness               | 2   |                     |
| 30   | U00035       | Grip                       | 2   |                     |
| 31   | U01497       | Overlay                    | 1   | (Not Shown)         |



# GSGDUE14D Wiring Diagram

