

Parts Catalogue

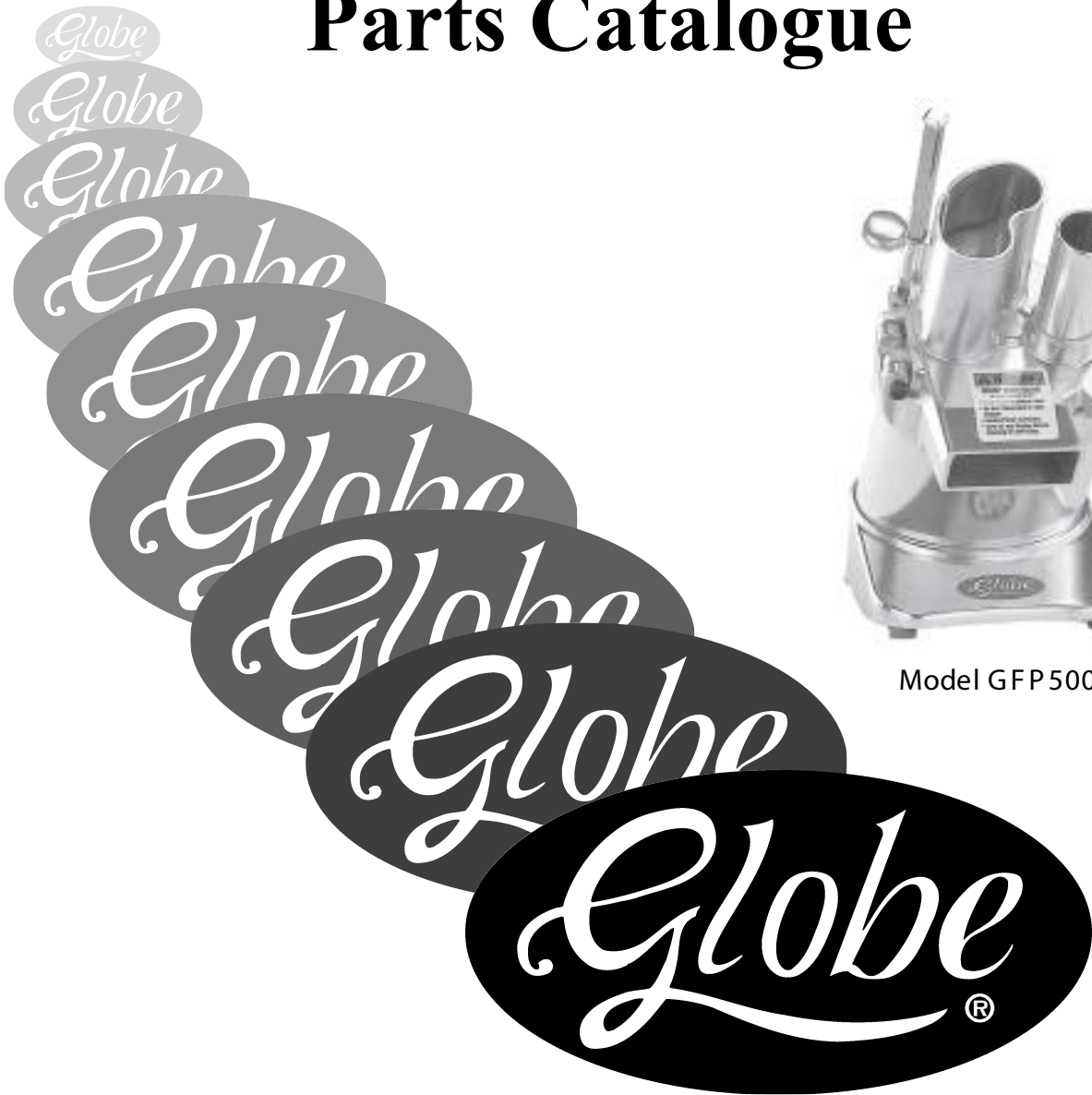

Model GFP 500

FOOD PROCESSORS

MODEL: GFP 500/550

3-6-2007

IMPORTANT!

TO EXPEDITE SHIPMENT OF PARTS, ALWAYS SPECIFY MODEL, REV,
PART NUMBER, AND SERIAL NUMBER OF PROCESSOR.

GLOBE FOOD EQUIPMENT COMPANY

P.O. Box 3209

Dayton, Ohio 45439

Parts Department

Toll Free 1-800-745-6238 • Fax (937) 290-0585

E-Mail: globeinfo@globeslicers.com

Website: www.globeslicers.com

GFP 500/550 BODY

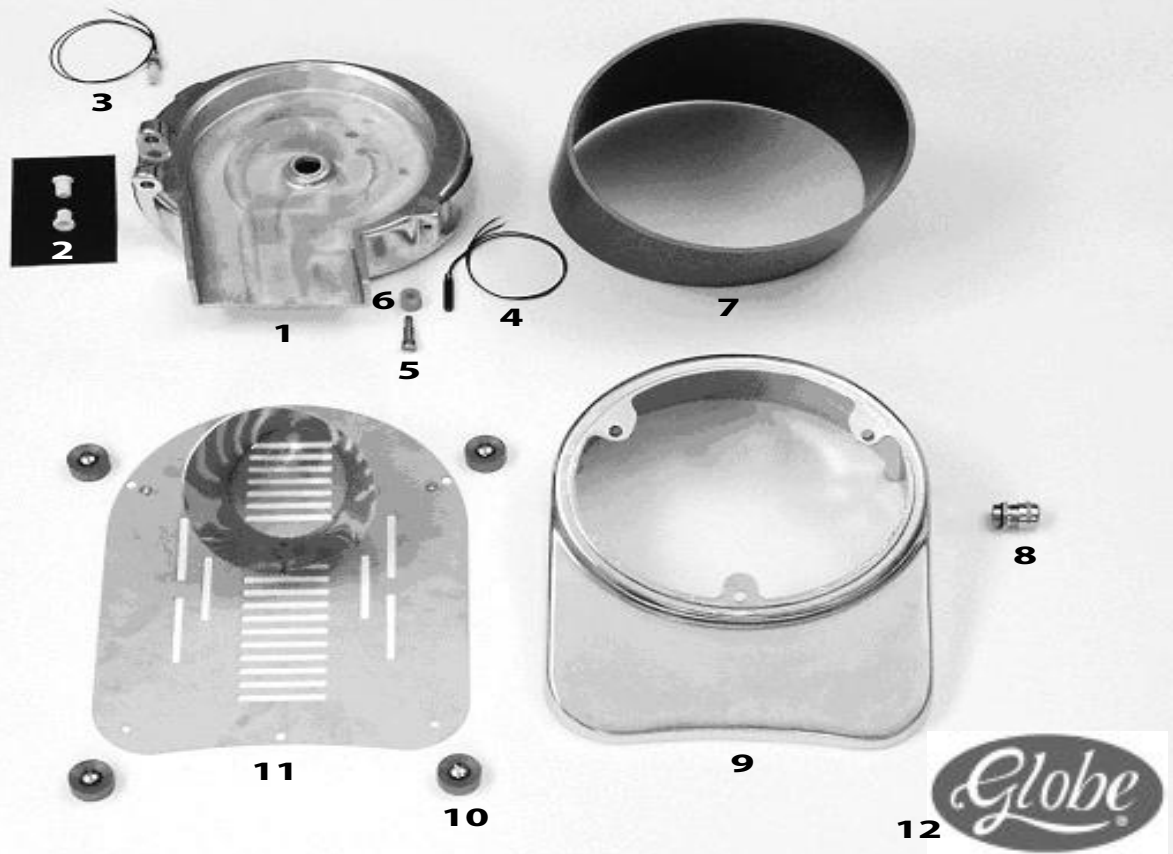

1.	UPPER HOUSING ASSEMBLY (COMPLETE)	F3511630
A.	UPPER HOUSING	F3511609
2.	BUSHINGS	F3521102
3.	REED SWITCH (GLIDE ROD) WHITE	F7084018
4.	REED SWITCH (ON/OFF) BLACK	F7084015
5.	LATCH ROLLER SCREW	F3511618
6.	LATCH ROLLER	F3511607
7.	HOUSING CENTER	F3511624
8.	STRAIN RELIEF	F7063023
9.	HOUSING LOWER	F3511612
10.	FOOT	F3521104
NOT SHOWN	FOOT SCREW	F8023102
11.	BOTTOM ENCLOSURE	F3511641
NOT SHOWN	BOTTOM ENCLOSURE SCREW	F8032182
12.	LABEL	871-3

GFP 550 HINGE LID

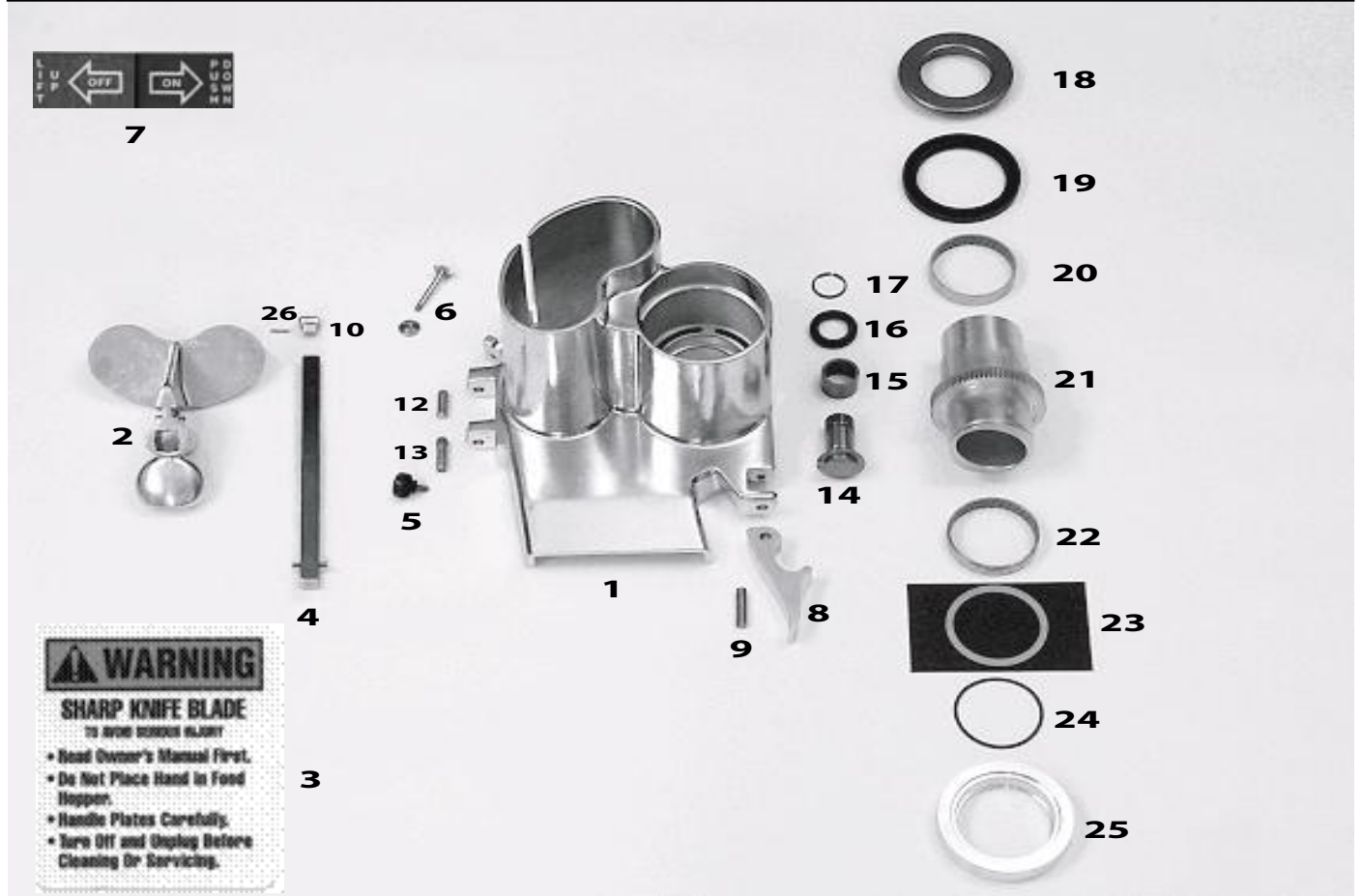

WARNING
SHARP KNIFE BLADE
 TO AVOID SCORCH BLUNT

- Read Owner's Manual First.
- Do Not Place Hand in Food Hopper.
- Handle Plates Carefully.
- Turn Off and Unplug Before Cleaning Or Servicing.

1.	HINGE LID ASSEMBLY (INCLUDES ALL PARTS)	F3111603
A.	HINGE LID	F3511601
2.	ALUMINUM FOOD PUSHER	F3511602
3.	WARNING LABEL	F000003
4.	GLIDE ROD SET	F3511646
5.	KNURL SCREW KNOB	F7313001
6.	AXLE & 2 KNURL NUTS	F3511644
	AXLE KNURL NUT	F3521602
7.	ON/OFF LABEL	F000002
8.	LATCH ASSEMBLY	F3511639
9.	PIVOT LATCH PIN	F3511118
10.	END PIECE	F3511123
12.	SHORT HINGE PIN	F3511645
13.	LONG HINGE PIN	F3511120
14.	PINION SHAFT	F3511129
15.	PINION BUSHING	F8211365
16.	LIP SEAL	F8261854
17.	CLIP RING	F8152204
18.	SEAL RING	F3511128
19.	LIP SEAL	F8263744
20.	SLIDE BEARING	F7339004
21.	INLET	F3511168
22.	SLIDE BEARING	F7339004
23.	LIP SEAL	F3521109
24.	O-RING	F8252384
25.	INSERT RING	F3511182
26.	GLIDE ROD PIN	F8182228

GFP 500 HINGE LID



7

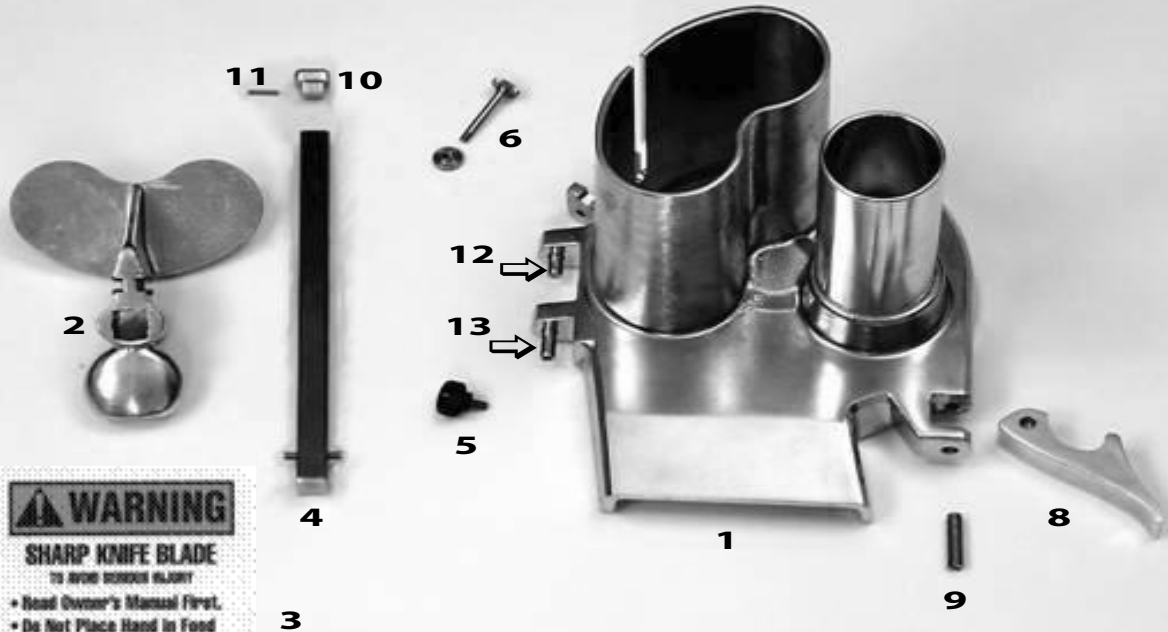

WARNING
SHARP KNIFE BLADE
 To avoid serious injury

- Read Owner's Manual first.
- Do Not Place Hand in Food Nipper.
- Handle Plates Carefully.
- Turn Off and Unplug Before Cleaning or Servicing.

1.	HINGE LID ASSEMBLY (INCLUDES ALL PARTS)	F3111610
A.	HINGE LID	F3511610
2.	ALUMINUM FOOD PUSHER	F3511602
3.	WARNING LABEL	F0000003
4.	GLIDE ROD SET	F3511646
5.	KNURLED SCREW KNOB	F7313001
6.	AXLE & 2 KNURL NUTS	F3511644
	AXLE KNURL NUT	F3521602
7.	ON/OFF LABEL	F0000002
8.	LATCH ASSEMBLY	F3511639
9.	PIVOT LATCH PIN	F3511118
10.	END PIECE	F3511123
11.	PIN	F8182228
12.	SHORT HINGE PIN	F3511645
13.	LONG HINGE PIN	F3511120

GFP 500/550 ELECTRICAL

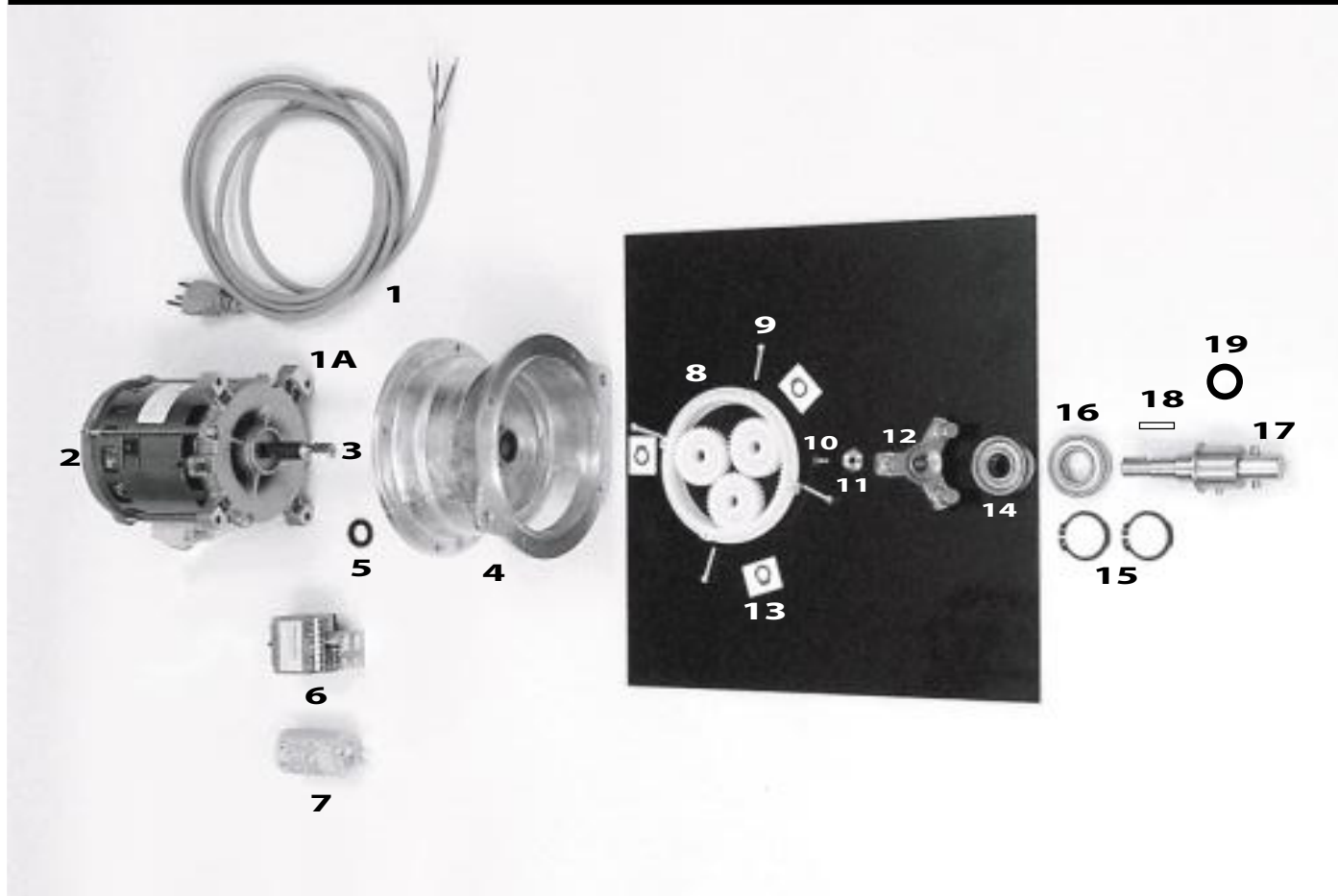

1.	CORD	132-3
1A.	ENDSHIELD	F3521114
2.	MOTOR ASSEMBLY	F3521112
3.	MOTOR PINION GEAR	F3521101
4.	GEAR/MOTOR FLANGE	F3511615
5.	LIP SEAL	F8261304
6.	RELAY/POWER SUPPLY	F7079003
7.	CAPACITOR	F7051008
8.	GEAR ASSEMBLY	F7335002
9.	SCREWS (4 REQUIRED)	F8013121
10.	SPINDLE SCREW	F8031331
11.	SPINDLE WASHER	F8131031
12.	GEAR SPINDLE	F3511619
13.	SNAP RING (3 REQUIRED)	F8152084
14.	LOWER BEARING	F8226033
15.	SNAP RING (BEARING, 2 REQ)	F8151294
16.	UPPER BEARING	F8224433
17.	DRIVE SHAFT	F3511616
18.	KEY	F8165393
19.	DRIVE SHAFT LIP SEAL	F8261944
NOT SHOWN	GREASE	521
NOT SHOWN	MOTOR MOUNT SCREWS (4 REQ)	F8013211
NOT SHOWN	MOTOR MOUNT WASHER (4 REQ)	F8141036
NOT SHOWN	MOTOR COOLING FAN	F1521654

GFP500/550

