

Parts Catalog



GEG36

Medium Duty Electric Griddle

Model: GEG36

5/5/2023 Rev. E

IMPORTANT!

TO EXPEDITE SHIPMENT OF PARTS, ALWAYS SPECIFY MODEL, REV,
PART NUMBER, AND SERIAL NUMBER OF UNIT.

GLOBE FOOD EQUIPMENT COMPANY

2215 East River Road
Dayton, Ohio 45439

Parts Department

Toll Free 1-800-745-6238 · Fax (937) 290-0585

E-Mail: info@globefoodequip.com

Website: www.globefoodequip.com

Not for resale

Table of Contents

Description

Page

GEG36 Electric Griddle Components

4

GEG36 Electric Griddle Schematic

6



GEG36 Electric Griddle Components

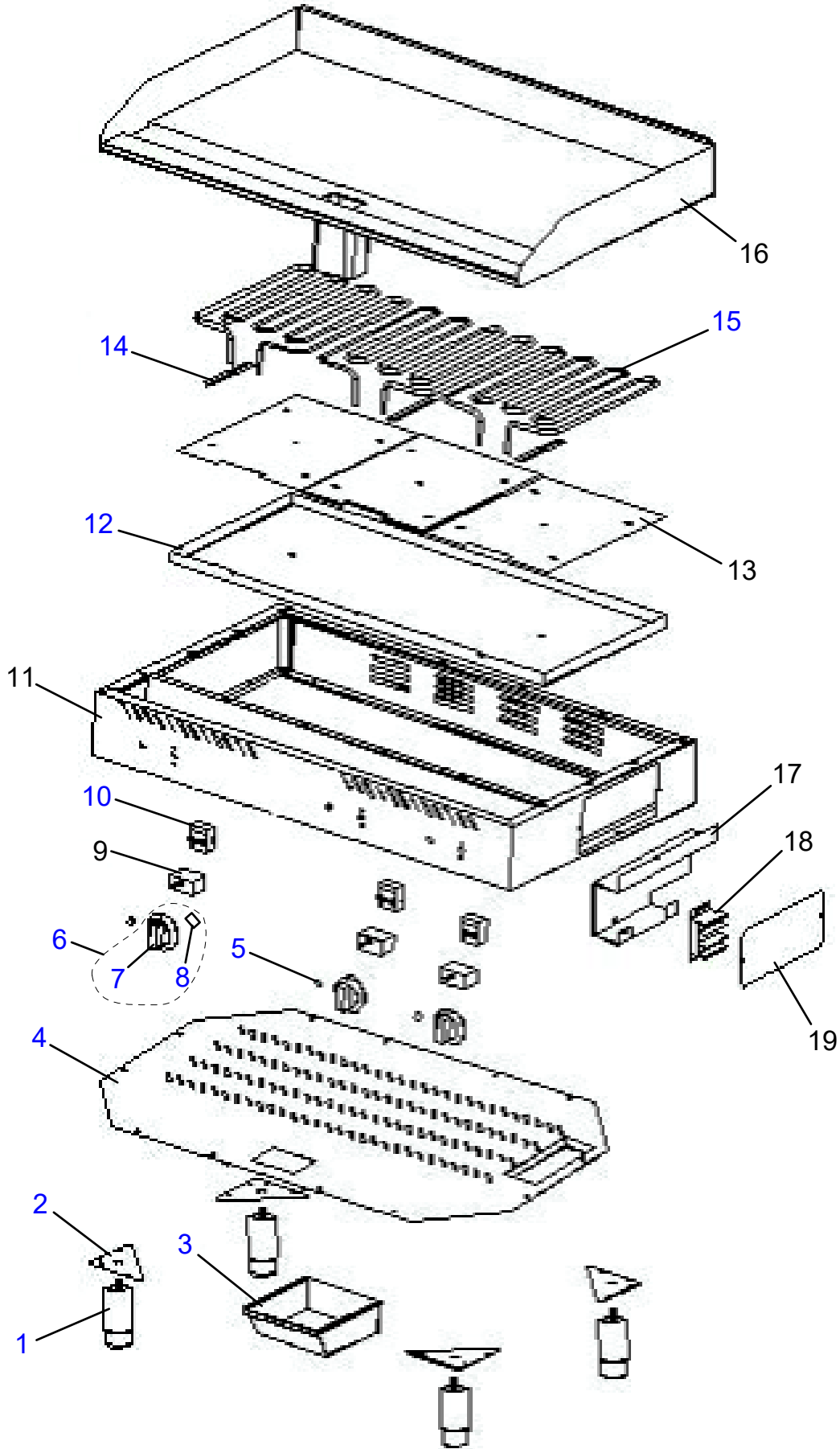



GEG36 Electric Griddle Components

Item	Part Number	Description	Qty	Serial Number
1	U01021005165	Foot	4	
2		Plate	4	
3	U01051025574	Drip Tray	1	
4	U06051470641	Base Plate	1	
5	U03091240006	Indicator Light	2	
6	U01033	Knob Kit	2	
7		Dial	1	
8		Spring Plate	1	
9	U03041215033	ON/OFF Switch	2	
10	U03051220048	Thermostat	2	
11		Enclosure Assembly	1	
12	U01071040230	Insulation Plate	1	
13	U01991090036	Element Plate	2	
14	U01051027329	Sensor Plate	2	
15	U03061225104	Heating Element	2	
16		Plate, Griddle	1	
17	U01051027332	Connection Box	1	
18	U03081235018	Terminal Block	1	
19	U01051027359	Connection Box Cover	1	
20	U02539	Overlay	(Not Shown)	1
21	U03021205011	Powercord (240V)	(Not Shown)	1



GEG36 Electric Griddle Schematic

- NOTE:**
1. USE ONLY COPPER WIRE FOR SUPPLY CONNECTIONS. WIRE TO BE SUITABLE FOR AT LEAST 90°C (194°F). USE WIRE GAUGE SHOWN OR LARGER.
 2. ALL INTERNAL WIRING IS #14 GAUGE.

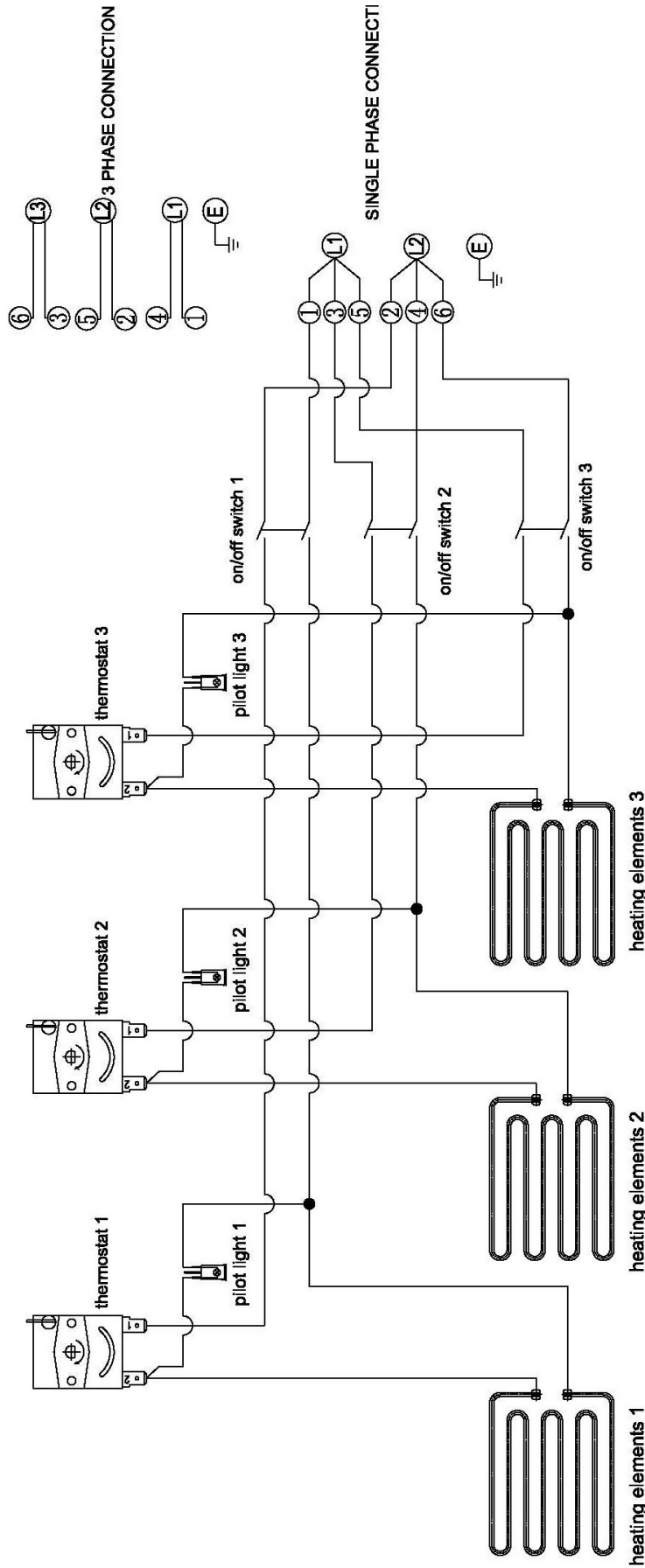

NOMINAL AMPS PER LINE			
208V ~ 3 PHASE	240V ~ 3 PHASE		
6,300 WATTS		8,400 WATTS	
L1	L2	L1	L3
17.49	17.49	20.21	20.21
AWG #10	AWG #10	AWG #10	AWG #10
		AWG #8	AWG #6
		30.29	35
		1 PH	1 PH
		208V	240V