

Parts Catalog



G12E-220-240501

Slicing Machine

Model: **G12E-220-240501**

5/22/23 Rev A

IMPORTANT!

TO EXPEDITE SHIPMENT OF PARTS, ALWAYS SPECIFY MODEL, REV,
PART NUMBER, AND SERIAL NUMBER OF UNIT.

GLOBE FOOD EQUIPMENT COMPANY

2215 East River Road
Dayton, Ohio 45439

Parts Department

Toll Free 1-800-745-6238 · Fax (937) 290-0585

E-Mail: info@globefoodequip.com

Website: www.globefoodequip.com

Not for resale

Table of Contents

Description	Page
G12E Base Components	4
G12E Chute Components	8
G12E Knife and Sharpener Components	10
G12E Electrical Components	12
G12E Wiring Diagram - 220, 50 Hz, 1PH	14



G12E Base Components

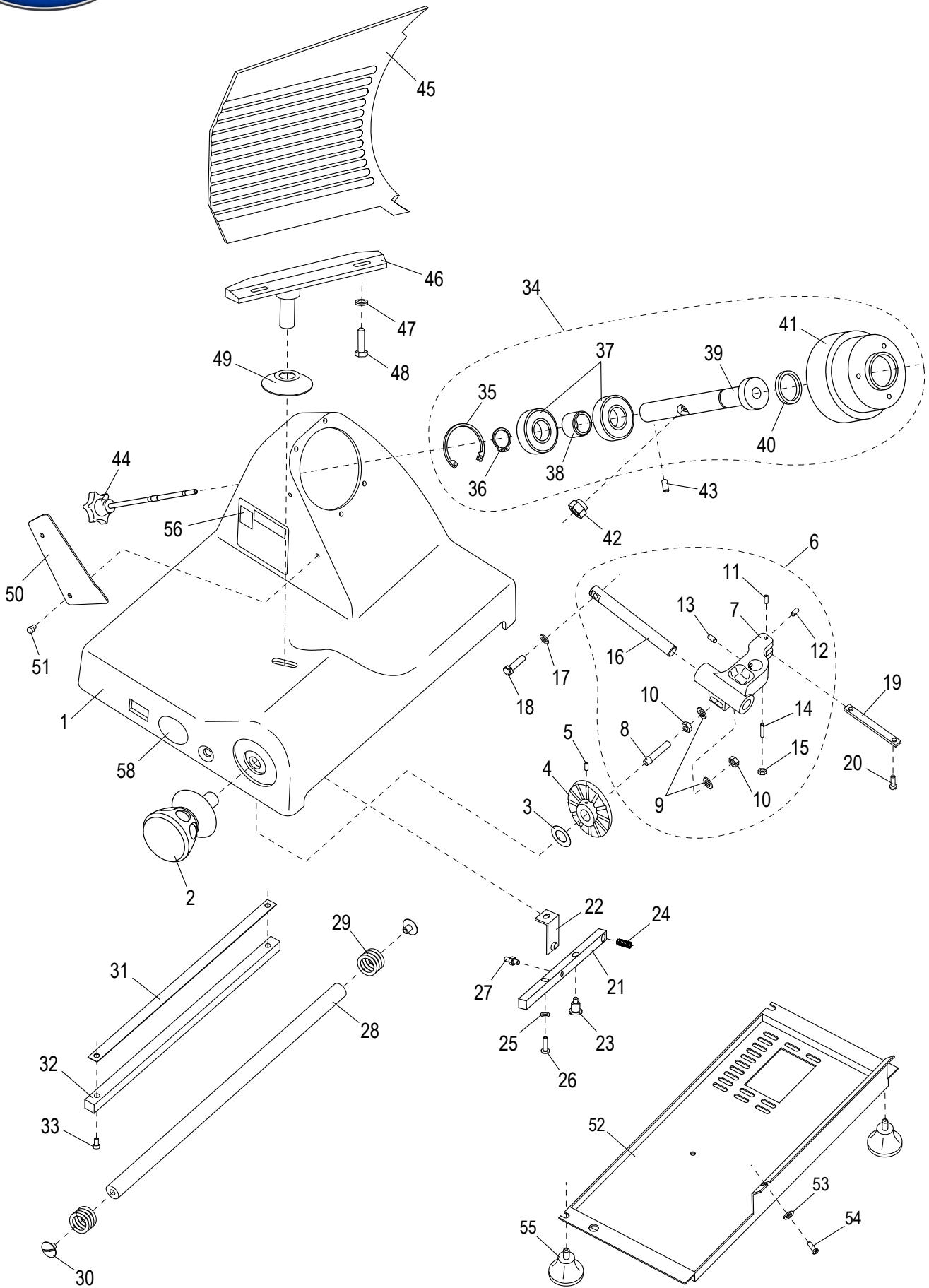



G12E Base Components

Item	Part Number	Description	Qty	Serial Number
1		Slicer Base	1	
2	M00234	Table Adjustment Knob	1	
3	M003	Wave Washer	1	
4	M00235	Cam	1	
5	H00181	Set Screw	2	
6	M305	Table Slide Assembly	1	
7		Table Slide	1	
8	M03026	Threaded Rod	1	
9	X08101	Washer M8x16mm Flat	2	
10	H00192	Hex Nut M8-1.25,13mm Width,4 mm Height-Zn	2	
11	H00182	Set Screw M5x10 Flat Pt Slotted - Zn	1	
12	H00185	Set Screw	1	
13	H00186	Set Screw M8-1.25x10 Cup Pt. Hex Socket - BO	2	
14	H00188	Set Screw	1	
15	X30186	Hex Nut M5-0.8 OD-8, TH-4mm, Zinc	1	
16	MR36	Table Slide Rod	1	
17	X08101	Washer M8x16mm Flat	2	
18	H00116	Hex Head Screw M6-1.0x20 - Zn	2	
19	M016	Table Slide Plate	1	
20	H00061	Hex Head Screw M5x10, Zinc	2	
21	M00295	Release Lever	1	
22	M00296	Release Lever Bracket	1	
23	M02473	Screw	1	
24	M00298	Spring	1	
25	H00063	Flat Washer, M5, Zinc	1	
26	H00187	Cheese Hd Screw M5-0.8x16 Slotted - Zn	1	
27	M00292	Threaded Rod	1	
28	M059	Round Slide Rod	1	
29	M061	Spring	2	
30	M060	Screw	2	
31	M063	Wear Strip	1	
32	M062	Square Slide Bar	1	
33	H00056	Screw	2	
34	M319	Knife Hub Assembly	1	
35		Retaining Ring, Internal	1	
36	H00195	Retaining Ring, External	1	
37	M020	Bearing (6204 6RS)	2	
38		Spacer, Knife Pulley	1	
39		Shaft, Knife Hub	1	
40	MR12/7	Oil Seal	1	
41		Pulley, Knife Hub	1	
42	MCR61	Knife Hub Nut	1	
43	H00184	Set Screw	1	
44	M00225	Knife Cover Release Knob	1	
45	M00232	Table	1	
46	M00227	Table Support	1	
47	X08101	Washer M8x16mm Flat	2	
48	H00196	Screw	2	
49	M00646	Hole Cover	1	
50	M02476	Slice Deflector	1	
51	MCC23	Thumb Screw	2	
52	M02477	Bottom Cover	1	
53	H00063	Flat Washer, M5, Zinc	1	



G12E Base Components

Item	Part Number	Description	Qty	Serial Number
54	H00061	Hex Head Screw M5x10, Zinc	1	
55	M115	Foot	4	
56	M91022	Warning Label	1	
57	82-F	French Warning Label (Not Shown)	1	
58	M91021	Globe Logo	1	



INTENTIONALLY LEFT BLANK PAGE



G12E Chute Components

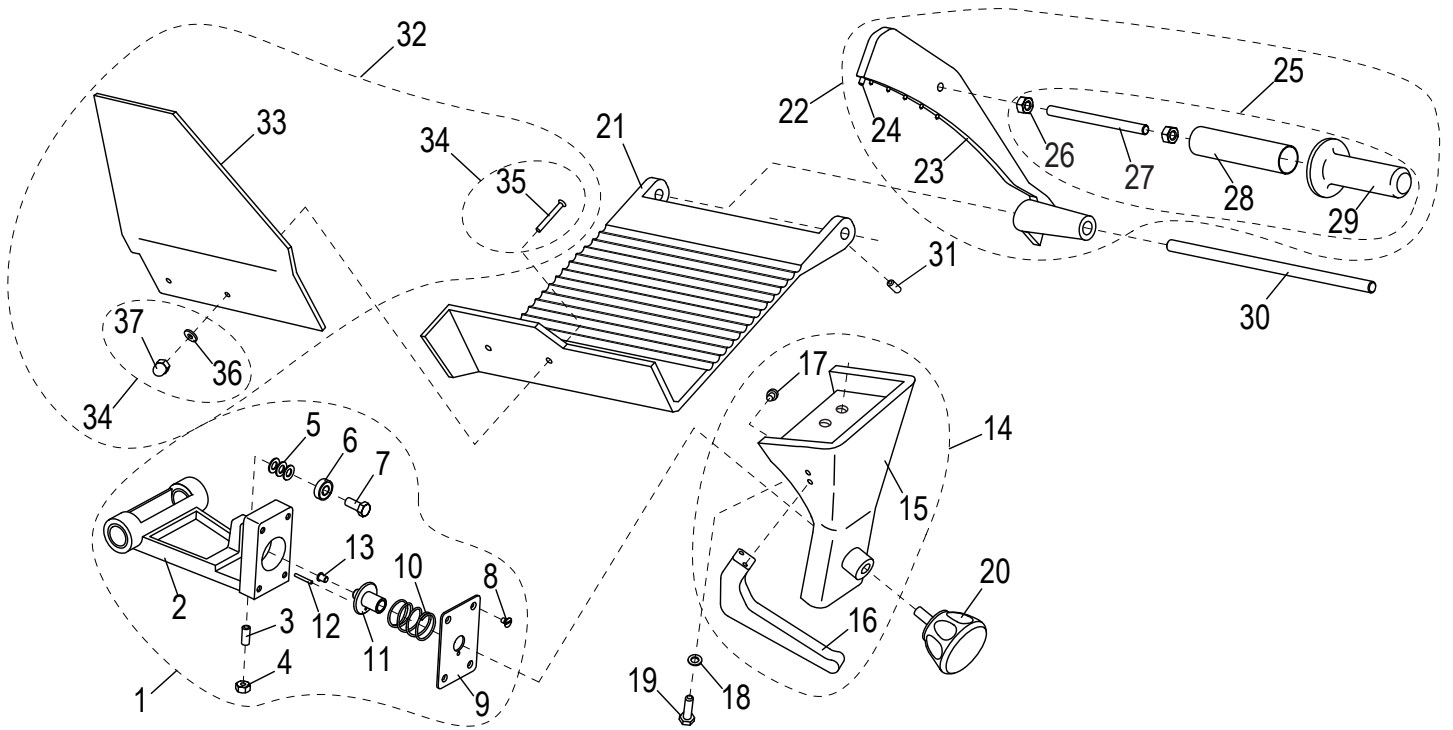



G12E Chute Components

Item	Part Number	Description	Qty	Serial Number
1	M00172	Chute Slide Assembly (Incl. items 2-13)	1	
2		Chute Slide	1	
3	M053	Brass Stud	1	
4	H00192	Hex Nut M8-1.25,13mm Width,4 mm Height-Zn	1	
5	X08101	Washer M8x16mm Flat	3	
6	M056	Bearing (608 2RS)	1	
7	M00306	Screw	1	
8	H00309	Screw	4	
9	M00175	Plate	1	
10		Release Spring	1	
11	M00173	Internal Release	1	
12	M00307	Threaded Rod	1	
13	M00308	Release Cap	1	
14	M00176	Chute Support Assembly (Incl. items 15-17)	1	
15		Chute Support	1	
16	M067	Chute Support Handle	1	
17	H00156	Ext. Hex Hd M6x1.0x12 mm Screw Zinc 8.8	2	
18	X08101	Washer M8x16mm Flat	2	
19	H00117	Hex Head Screw M8x20 - Zn	2	
20	M00312	Chute Support Knob	1	
21	M00177	Chute	1	
22	M00179	End Weight Assembly (Incl. items 23-29)	1	
23		End Weight	1	
24	MC39	Bumper	1	
25	M00342	End Weight Handle Kit (Incl. items 26-29)	1	
26	H00341	Nut	2	
27	M00339	Threaded Rod	1	
28	M00340	Spacer	1	
29	MCC40/1	End Weight Handle	1	
30	M00178	End Weight Rod	1	
31	H00199	Set Screw	1	
32	M00169	Hand Guard Kit	1	
33		Hand Guard	1	
34	M00651	Hardware Kit	1	
35		Hand Guard Mounting Screw	2	
36		Hand Guard Washer	2	
37		Hand Guard Nut	2	



G12E Knife and Sharpener Components

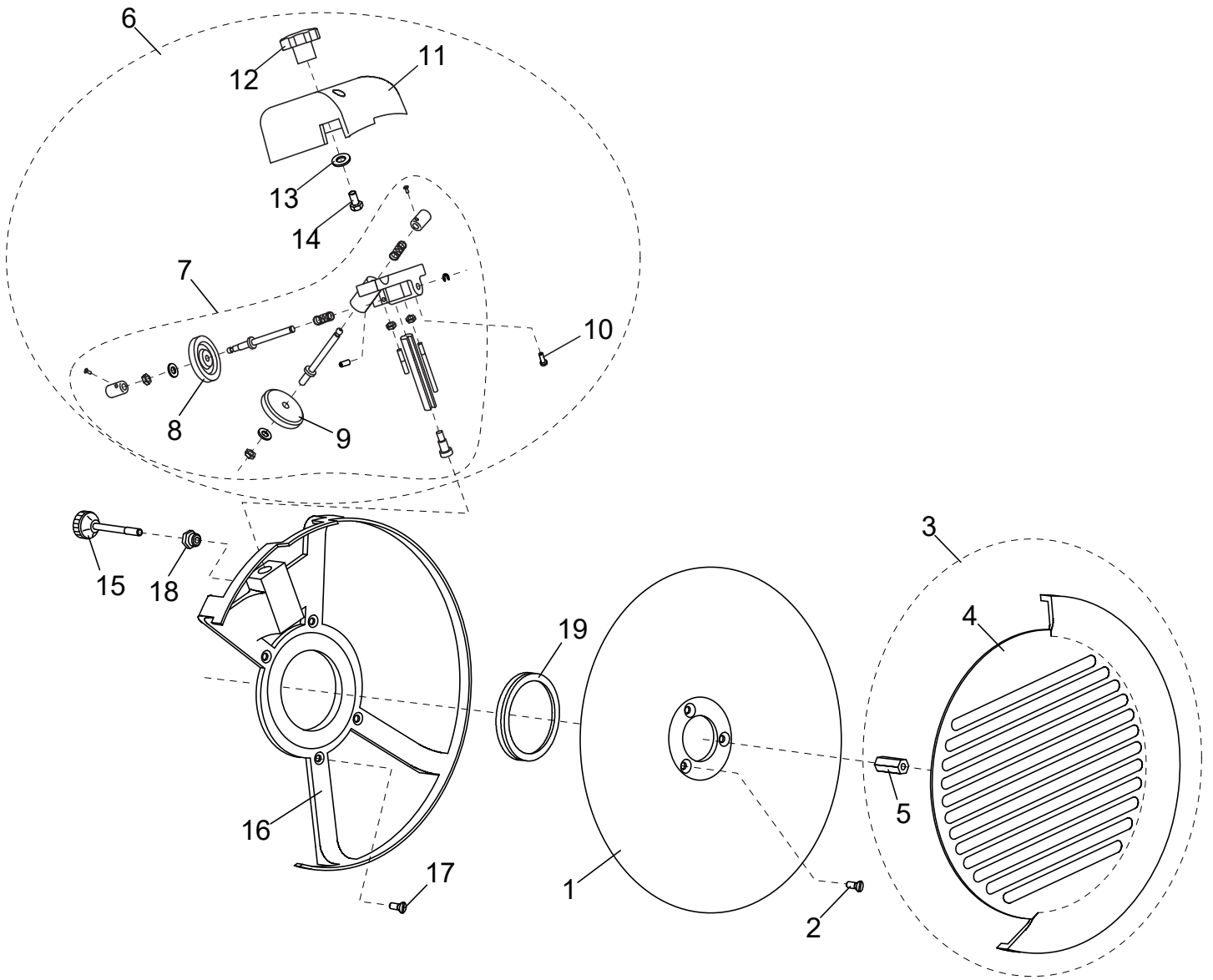



G12E Knife and Sharpener Components

Item	Part Number	Description	Qty	Serial Number
1	M00328	Knife	1	
2	H00201	Screw	3	
3	M349	Knife Cover Kit	1	
4		Knife Cover	1	
5	M049A	Insert	1	
6	M377	Complete Sharpener Assembly	1	
7	MC017	Sharpener Assembly	1	
8	M092	Deburring Stone	1	
9	MCC17	Sharpening Stone	1	
10	H00187	Cheese Hd Screw M5-0.8x16 Slotted - Zn	2	
11	M074	Sharpener Cover	1	
12	M075	Sharpener Cover Knob	1	
13	M035	Flat Washer ID 6.5 OD 12 TH 1.5 mm Zinc	1	
14	H00197	Hex Hd Screw M6x15 - Zn	1	
15	M096	Sharpener Release Knob	1	
16	M044	Rim Guard	1	
17	H00435	Screw	4	
18	M045	Insert	1	
19	MGI77/5	Knife Seal	1	

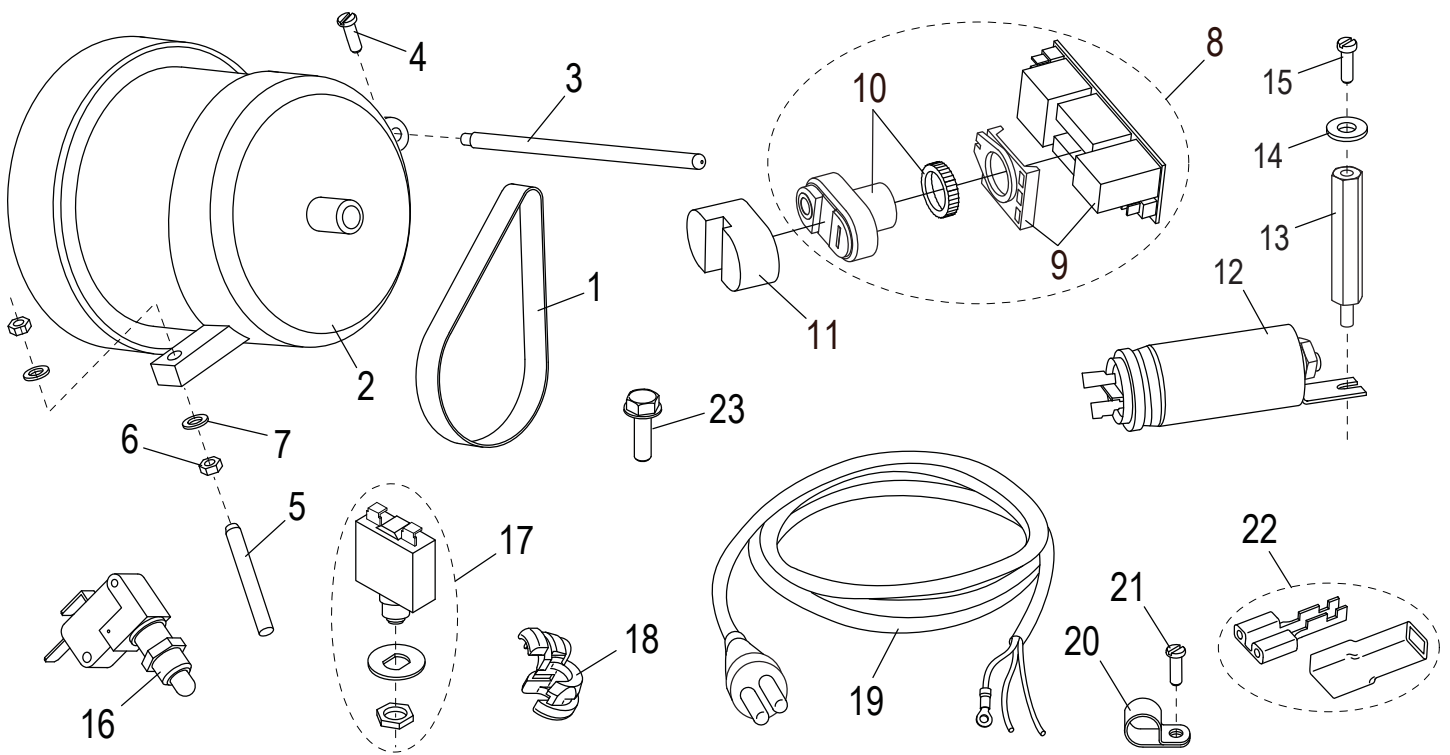



G12E Electrical Components

Item	Part Number	Description	Qty	Serial Number
1	M024	Belt	1	
2	M02479	Motor (230V/50HZ)	1	
3	M031	Pin	1	
4	H00189	Cheese Hd Screw M4-0.7x10 Slotted - Zn	1	
5	M033	Threaded Rod	1	
6	M034	Hex Nut M6x1.0 OD 10 mm TH 5 mm Zinc	2	
7	M035	Flat Washer ID 6.5 OD 12 TH 1.5 mm Zinc	2	
8	M02557	Power Switch Assembly	1	
9	M00351	Electrical Card	1	
10	M00350	Power Switch	1	
11	M00349	Power Switch Cover	1	
12	M02481	Capacitor	1	
13	M00358	Standoff	1	
14	M035	Flat Washer ID 6.5 OD 12 TH 1.5 mm Zinc	1	
15	H00061	Hex Head Screw M5x10, Zinc	1	
16	M026	Microswitch	1	
17	M038	Reset Switch	1	
18	M111	Strain Relief	1	
19	M02478	Power Cord	1	
20	M03023	Cable Clamp	1	
21	H00061	Hex Head Screw M5x10, Zinc	1	
22	M00233	Terminal & Insulator	12	
23	M00334	Ground Screw	1	

