

# Parts Catalog



**FS14**

## **Flywheel Slicer**

**Model: FS14**

5/12/2023 Rev B

IMPORTANT!

TO EXPEDITE SHIPMENT OF PARTS, ALWAYS SPECIFY MODEL, REV,  
PART NUMBER, AND SERIAL NUMBER OF UNIT.

## **GLOBE FOOD EQUIPMENT COMPANY**

2215 East River Road  
Dayton, Ohio 45439

### **Parts Department**

Toll Free 1-800-745-6238 · Fax (937) 290-0585

E-Mail: [info@globefoodequip.com](mailto:info@globefoodequip.com)

Website: [www.globefoodequip.com](http://www.globefoodequip.com)

Not for resale



# Table of Contents

Description	Page
FS14 Machine Base Components	4
FS14 Flywheel Components	6
FS14 Knife Blade Components	10
FS14 Carriage Assembly Components	12
FS14 Advacement Cart Components	16
FS14 Product Tray Components	20
FS14 Sharpener Assembly Components	24



# FS14 Machine Base Components

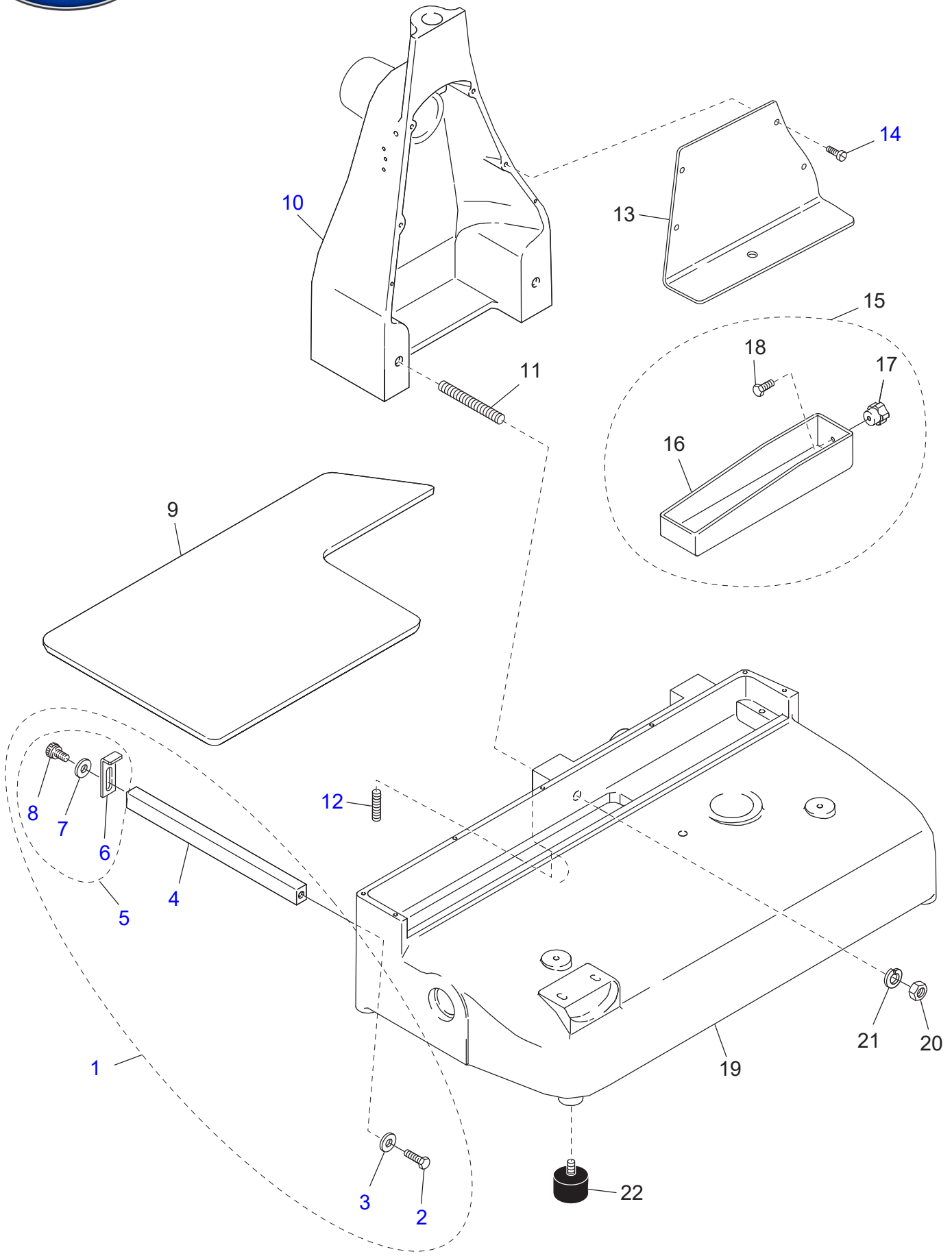



## FS14 Machine Base Components

Item	Part Number	Description	Qty	Serial Number
1	R01590	Support Bar Assembly	1	
2	H01571	Screw M8-1.25x25 mm, Hex Hd	2	
3	X30197	Ext. Hex Hd Screw M8-1.25x25mm, SS	2	
4	R01360	Support Bar	2	
5	R01919	Hardware Kit, Support Bracket	1	
6	R01361	Support Bracket, Tray	2	
7	H01573	Washer M4x12mm	2	
8	H01574	Thumb Screw	2	
9	R02574	Tray, SS	1	
10		Knife Housing	1	
11		Screw Stud M12-1.75x70mm	2	
12		Screw Stud M8-1.25x30mm	2	
13	R01364	Chain Guard	1	
14		Screw M3-0.5x7mm Flat Hd	4	
15	R01591	Drip Tray Assembly	1	
16		Drip Tray	1	
17	R01365	Knob Kit	1	
18	H01682	Nut M5-0.8 Hex	1	
19		Slicer Base	1	
20		Nut M12-1.75 Hex	2	
21	H00023	Flat Washer, M12 - Zn	2	
22	R01369	Foot	4	
23	R02010	Warning Label	1	(Not Shown)



# FS14 Flywheel Components

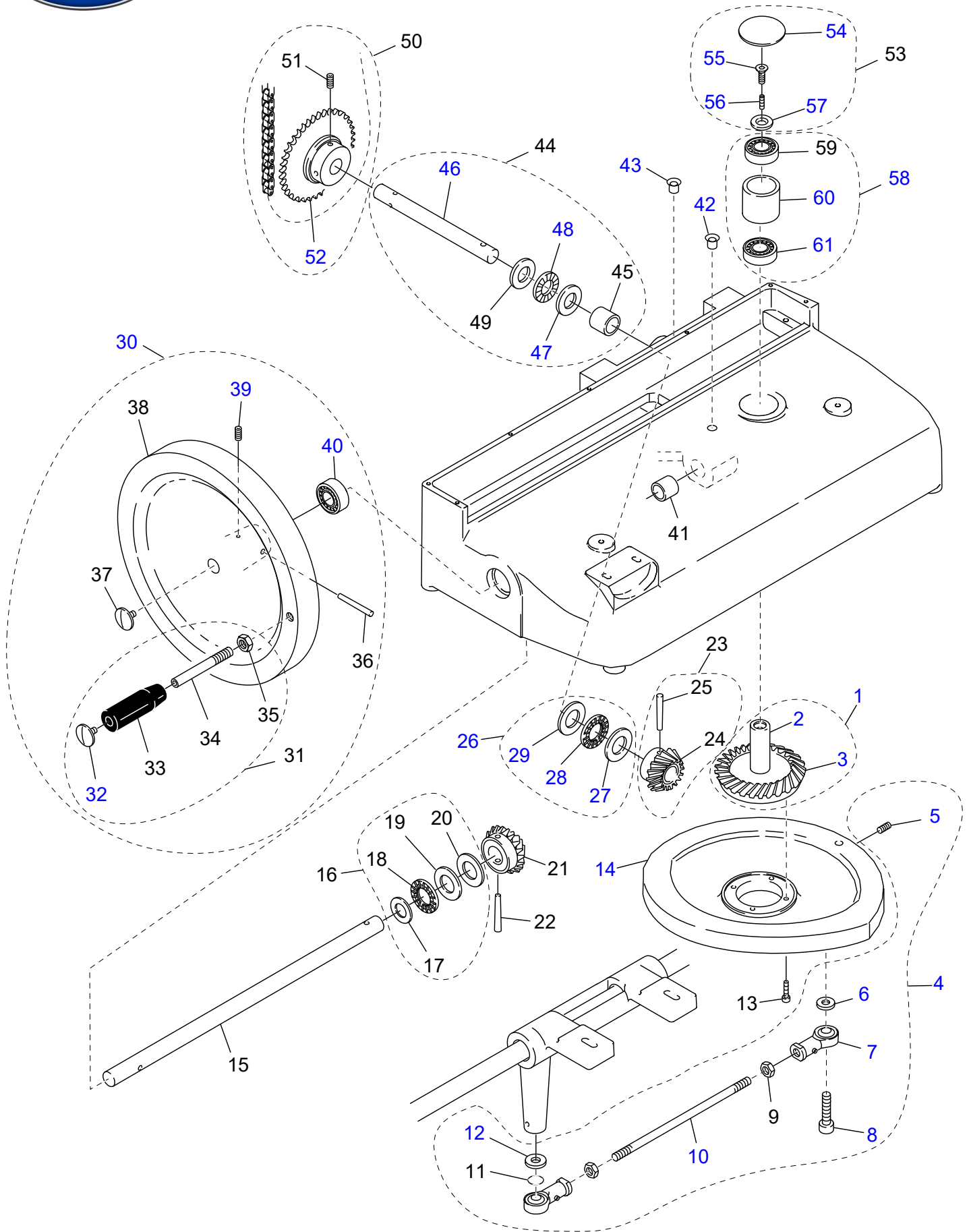



## FS14 Flywheel Components

Item	Part Number	Description	Qty	Serial Number
1	R01592	Bevel Gear Assembly	1	
2	R01373	Gear Shaft	1	
3	R01374	Bevel Gear	1	
4	R01593	Tie Rod Assembly	1	
5	H01683	Set Screw M6-1.0 x .7mm	4	
6	H00023	Flat Washer, M12 - Zn	1	
7		Tie Rod Joint	2	
8	H01684	Cap Screw M12-1.75x45mm Socket Hd	2	
9		Nut M12-1.25 Hex Jam	2	
10		Tie Rod	1	
11		O-ring M12	1	
12	H00023	Flat Washer, M12 - Zn	1	
13	H01878	Cap Screw, Socket Hd	4	
14		Inertia Chute Drive	1	
15	R01377	Flywheel Shaft	1	
16	R01597	Bearing Kit	1	
17		Axle Bearing	1	
18		Axle Bearing	1	
19		Axle Bearing	1	
20		Axle Bearing	1	
21	R01378	Gear	1	
22	R01595	Tapered Pin	1	
23	R01596	Gear & Tapered Pin Assembly	1	
24	R01379	Gear	1	
25	R01595	Tapered Pin	1	
26	R01597	Bearing Kit	1	
27		Axle Bearing	1	
28		Axle Bearing	1	
29		Axle Bearing	1	
30	R01957	Flywheel Assembly	1	
31	R01598	Handle Assembly	1	
32	R01687	Chrome Screw	1	
33		Operating Handle, Flywheel	1	
34	R01381	Pin M12-1.75x50 mm	1	
35		Nut M12-1.25 Hex Jam	1	
36	R01595	Tapered Pin	1	
37	R01687	Chrome Screw	1	
38		Flywheel	1	
39	H01683	Set Screw M6-1.0 x .7mm	1	
40	R01688	Bearing	1	
41	R01383	Bushing	1	
42	R01384	Oil Fitting	1	
43	R01384	Oil Fitting	1	
44	R01599	Gear Shaft Assembly	1	
45	R01383	Bushing	1	
46	R01384	Oil Fitting	1	
47		Axle Bearing	1	
48		Axle Bearing	1	
49		Axle Bearing	1	
50	R01600	Lower Chain Sprocket Kit	1	
51	H01683	Set Screw M6-1.0 x .7mm	1	
52		Sprocket	1	
53	R01877	Cap Assembly	1	



## FS14 Flywheel Components

---

Item	Part Number	Description	Qty	Serial Number
54	R01689	Cap	1	
55	H01690	Screw M8-1.25x20mm Socket Hd Cap	1	
56		Set Screw M5-0.8x30mm	1	
57	H00121	Flat Washer, Large Diameter M8 x 20 x 2 - Zn	1	
58	R01601	Bevel Gear Bearing Assembly	1	
59	R01692	Bearing	1	
60		Spacer	1	
61	R01692	Bearing	1	



*INTENTIONALLY LEFT BLANK PAGE*



# FS14 Knife Blade Components

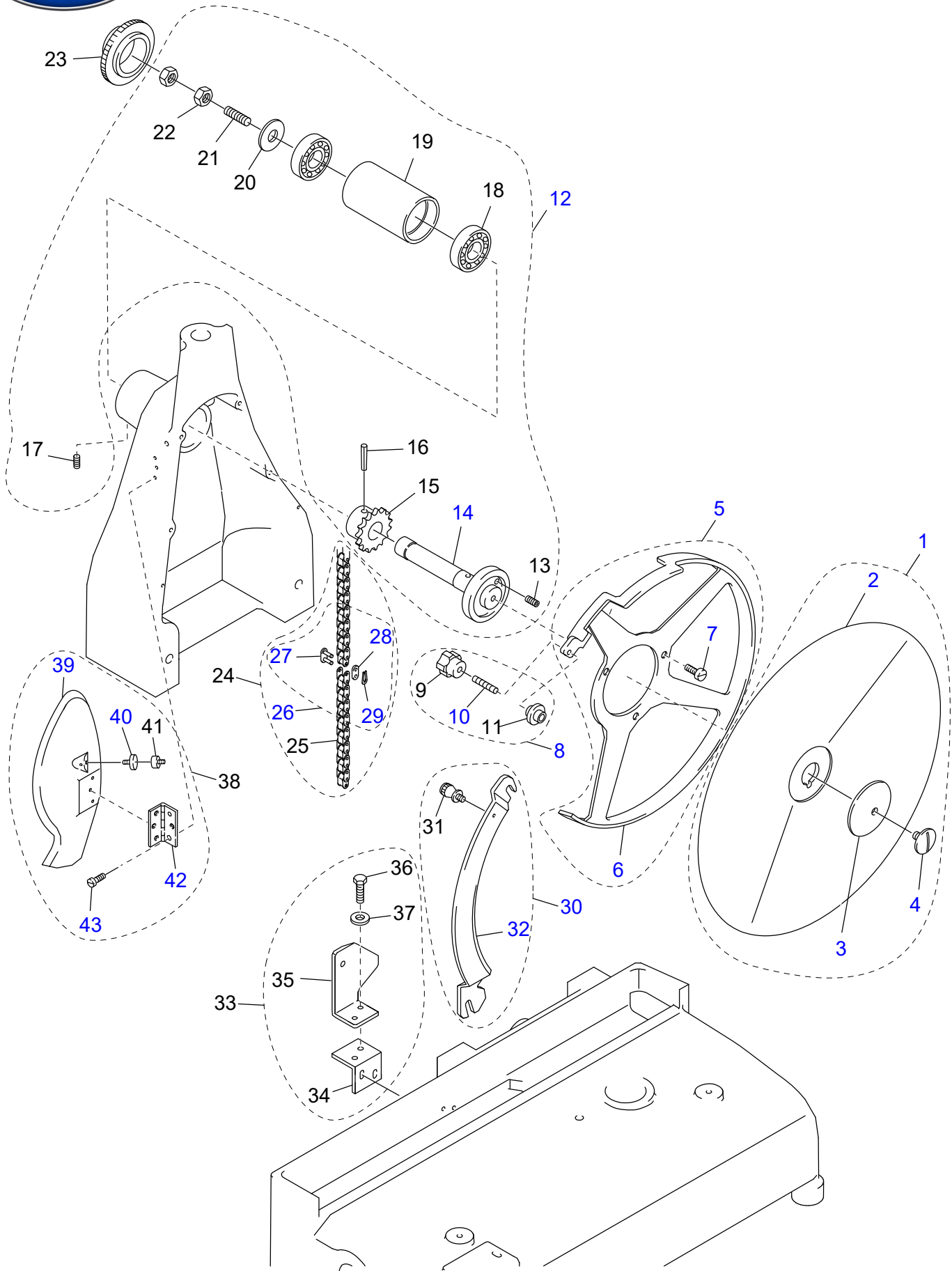



## FS14 Knife Blade Components

Item	Part Number	Description	Qty	Serial Number
1	R01784	Knife Securing Kit	1	
2	R01386	Knife	1	
3		Washer, Knife	1	
4	R01687	Chrome Screw	1	
5	R01602	Rim Guard Assembly	1	
6		Rim Guard, Knife	1	
7		Screw M6-1.0x13mm Flat Hd	3	
8	R01695	Rim Guard Knob Assembly	1	
9		Set Screw	1	
10		Thumb Screw	1	
11		Spacer	2	
12	R01603	Knife Bearing Assembly	1	
13		Set Screw M6-1.0x11mm Socket Hd	1	
14		Bearing and Shaft	1	
15		Gear	1	
16	R01595	Tapered Pin	1	
17		Set Screw M6-1.0x9mm Socket Hd	1	
18	R01692	Bearing	2	
19		Bearing Sleeve	1	
20	H01572	Washer M8x32mm	1	
21		Set Screw M8-1.25x20mm	1	
22	H01028	Nut M8	2	
23	R01614	Knife Shaft Cap	1	
24	R01604	Drive Chain Assembly	1	
25	R01605	Drive Chain	1	
26	R02562	Chain Connector	1	
27		Chain Link	1	
28		Chain Link	1	
29		Chain Link	1	
30	R01705	Knife Guard Assembly	1	
31	R01704	Thumb Screw	1	
32		Knife Guard	1	
33	R01607	Lower Bracket Assembly	1	
34		Bracket	1	
35		Bracket	1	
36		Screw M6-1.0x12mm Hex Hd	2	
37	M035	Flat Washer ID 6.5 OD 12 TH 1.5 mm Zinc	2	
38	R01610	Slice Deflector Assembly	1	
39		Slice Deflector	1	
40	R01613	Magnet	1	
41	H01707	Screw M5x13mm Flat Hd Slotted	1	
42	R01611	Hinge	1	
43	H01708	Thumb Screw	3	



# FS14 Carriage Assembly Components

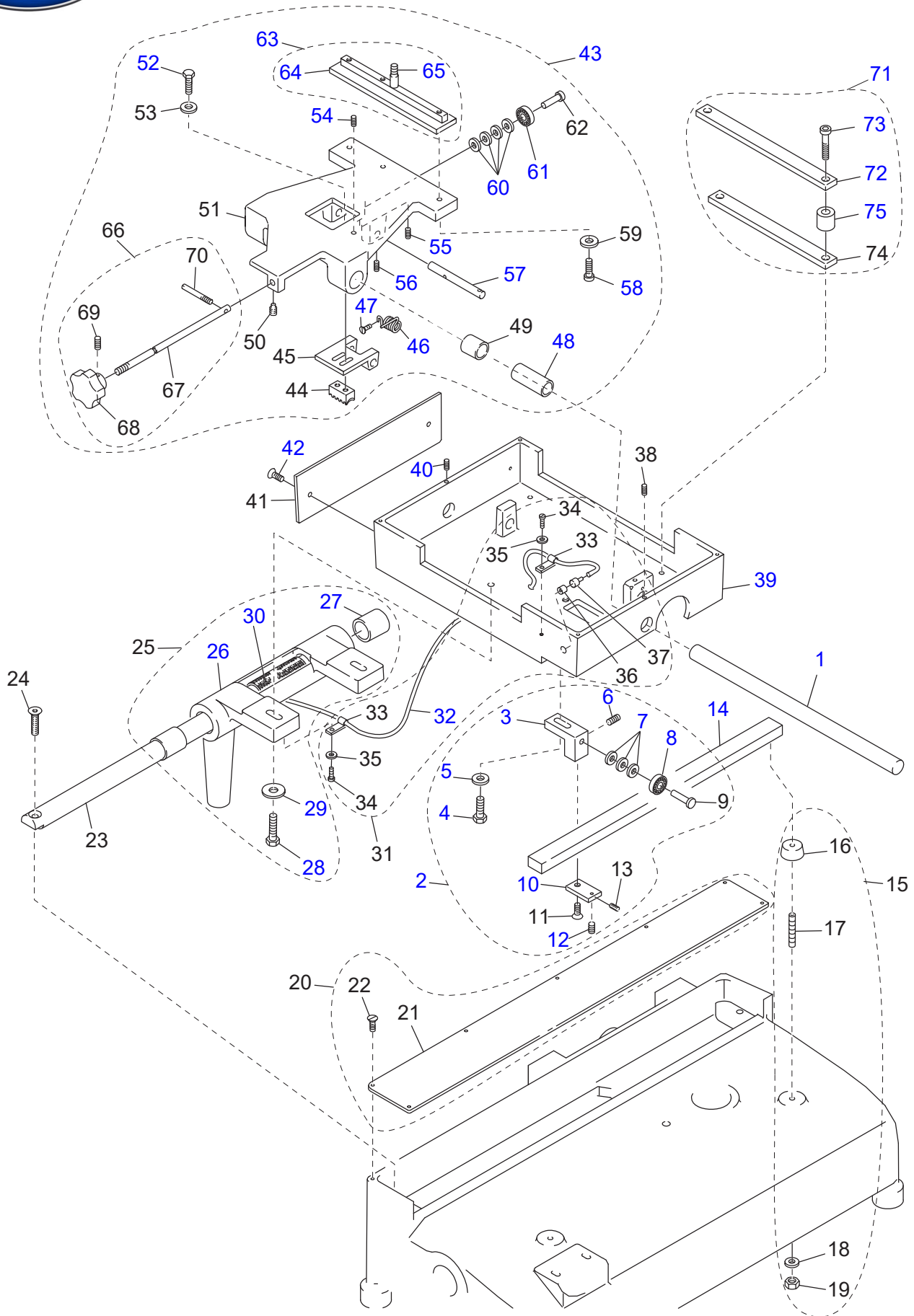



## FS14 Carriage Assembly Components

Item	Part Number	Description	Qty	Serial Number
1	R01785	Slide Rod	1	
2	R01615	Bearing Assembly, Slide Bar	1	
3		Support Bracket, Slide Bar	1	
4	X30197	Ext. Hex Hd Screw M8-1.25x25mm, SS	1	
5		Washer M8	1	
6		Set Screw M5x0.8x7mm Hex Socket	1	
7		Washer M8	3	
8	R01692	Bearing	1	
9		Pin	1	
10		Nut Plate	1	
11		Screw M6x1.0x6mm Socket Hd	1	
12		Set Screw M8x1.25x8mm	1	
13		Set Screw M5x0.5x39mm Socket Hd	1	
14	R01618	Slide Bar	1	
15	R01619	Slide Rod Mount Assembly	2	
16		Bumper, Rubber	2	
17		Set Screw M6x1.0x50mm Socket Hd	2	
18		Washer M6x20mm	2	
19		Acorn Nut M6-1.0mm	2	
20	R01621	Slide Rod Cover Assembly,	1	
21		Cover, Slide Bar	1	
22		Screw M8-39x0.5 Hex Hd	7	
23	R01623	Slide Rod	1	
24	H01690	Screw M8-1.25x20mm Socket Hd Cap	1	
25	R01624	Slide Assembly	1	
26		Slide	1	
27	R01383	Bushing	2	
28		Screw M8-1.25x40mm Hex Hd	2	
29	H01572	Washer M8x32mm	2	
30	R01626	Felt Insert	1	
31	R01627	Oil Supply Tube Assembly	1	
32		Tube, Oil Supply	1	
33		Loop Clamp	2	
34		Screw M4-0.7x10mm Flat Hd	2	
35		Washer M4x12mm Flat	2	
36	R01384	Oil Fitting	1	
37		Inox Compass	1	
38		Screw M6-1.0x15mm Socket Hd Cap	1	
39		Carriage Base	1	
40		Screw M6-1.0x15mm Socket Hd Cap	1	
41	R01631	Back Carriage Cover	1	
42		Screw M6-39x0.5 mm Phillips	2	
43	R01632	Carriage Mechanism Assembly	1	
44	R01803	Comb Block	1	
45		Support Mount, Carriage	1	
46	R01803	Comb Block	1	
47		Screw M4-0.7x10mm Flat Hd	1	
48	R01383	Bushing	1	
49	R01383	Bushing	1	
50		Set Screw M5-0.8x17mm Socket Hd	1	
51		Slide, Carriage	1	
52		Screw M6-1.0x13mm Hex Hd	2	
53		Washer M6x12mm Flat	2	



## FS14 Carriage Assembly Components

Item	Part Number	Description	Qty	Serial Number
54		Set Screw M6-1.0x10mm Socket Hd	1	
55		Set Screw M6-1.0x8mm Socket Hd	2	
56		Set Screw M5-0.8x8mm Socket Hd	1	
57		Pin, Tapered	1	
58		Screw M6-1.0x22mm Hex Hd	3	
59	M035	Flat Washer ID 6.5 OD 12 TH 1.5 mm Zinc	3	
60	M035	Flat Washer ID 6.5 OD 12 TH 1.5 mm Zinc	4	
61	R01692	Bearing	1	
62		Screw M6-1.0x22mm Hex Hd	1	
63	R01635	Product Holder Mount Assembly	1	
64		Mount, Product Holder	1	
65		Mount Stud, Product Holder	1	
66	R01637	Fast Forward Knob Assembly	1	
67		Rod, Fast Forward	1	
68		Knob, Fast Forward	1	
69		Set Screw M6-1.0x8mm Socket Hd	1	
70	R01381	Pin M12-1.75x50 mm	1	
71	R01640	Slide Bar Assembly, Inner Carriage	1	
72		Slide Bar, Inner Carriage	1	
73		Screw M6-1.0x16mm Socket Hd Cap	2	
74		Slide Bar, Inner Carriage	1	
75		Spacer	2	



*INTENTIONALLY LEFT BLANK PAGE*



# FS14 Advacement Cart Components

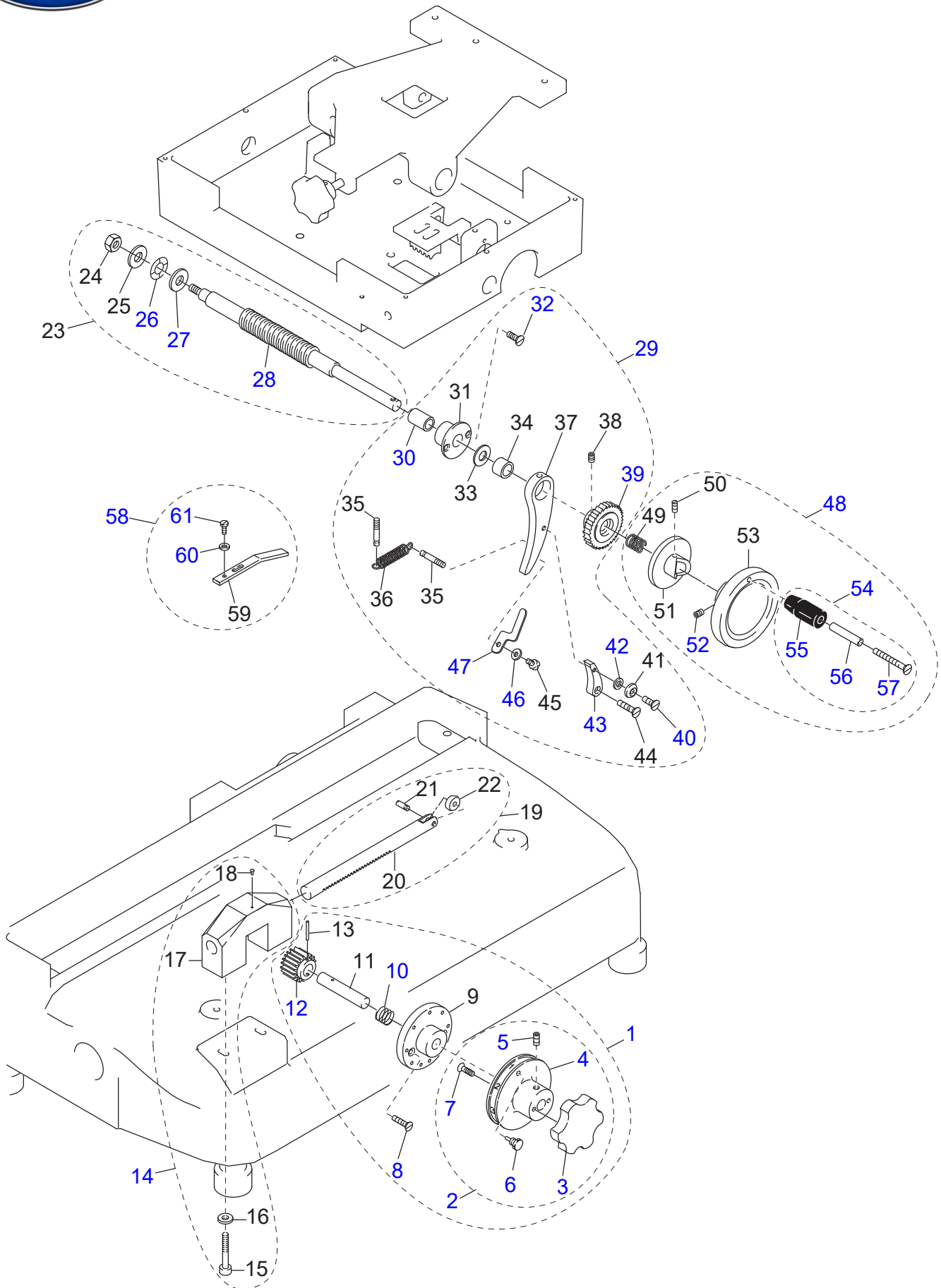



## FS14 Advacement Cart Components

Item	Part Number	Description	Qty	Serial Number
1	R01643	Control Knob Assembly	1	
2	R01645	Index Knob Assembly	1	
3		Control Knob, Thickness	1	
4		Index Guide	1	
5		Set Screw M6-1.0x8mm Socket Hd	1	
6		Screw M6-1.0x10mm Hex Hd	2	
7		Screw M4-0.7x15mm Flat Hd	2	
8		Screw M5-0.8x17mm Flat Hd	2	
9		Index Guide Cam	1	
10		Spring	1	
11		Pin	1	
12		Gear	1	
13		Pin, Tapered	1	
14	R01648	Index Mount Assembly	1	
15		Screw M6-1.0x45mm Socket Hd Cap	2	
16		Washer M6 Flat	2	
17		Mount, Index	1	
18		Revit	1	
19	R01650	Toothed Shaft Assembly	1	
20		Cam Pin	1	
21		Set Screw	1	
22		Plastic Roller	1	
23	R01652	Feed Screw Shaft Assembly	1	
24	H01028	Nut M8	2	
25		Washer M8	1	
26		Washer M6x12mm Flat	1	
27		Wave Washer	1	
28		Shaft, Feed Screw	1	
29	R01654	Skip Latch Assembly	1	
30	R01383	Bushing	1	
31		Bushing, Feed Screw	1	
32		Screw M4-0.7x10mm Flat Hd	2	
33		Washer M14x15IDx25ODmm Oversized	1	
34		Spacer	1	
35		Pin M5x0.8x26mm	2	
36		Spring	1	
37		Skip Latch, Large	1	
38		Set Screw M6-1.0x4mm Socket Hd	1	
39		Gear	1	
40		Screw M5-0.8x16mm Flat Hd	1	
41		Washer M5x15ODmm Flat	2	
42		Washer M5x12ODmm Flat	1	
43		Skip Latch, Small	1	
44		Screw M5-0.8x20mm Flat Hd	1	
45		Screw M4-0.7x6mm Hex Hd	1	
46		Washer M5x10ODmm Flat	1	
47		Spring, Skip Latch	1	
48	R01657	Handwheel Assembly	1	
49		Spring	1	
50		Set Screw M5-0.8x10mm	1	
51		Plate, Handwheel	1	
52		Set Screw M6-1.0x9mm Socket Hd	1	
53		Handwheel	1	



## FS14 Advacement Cart Components

---

Item	Part Number	Description	Qty	Serial Number
54	R01848	Product Holder Handle Assembly	1	
55		Sliding Product Holder Operating Handwheel	1	
56		Pin	1	
57		Pin M6-1.0x50mm Flat Hd	1	
58	R01660	Spring Bracket Assembly	1	
59		Bracket	1	
60		Washer M4x11OD mm Flat	2	
61		Screw M4-0.7x10mm Flat Hd	2	



*INTENTIONALLY LEFT BLANK PAGE*



# FS14 Product Tray Components

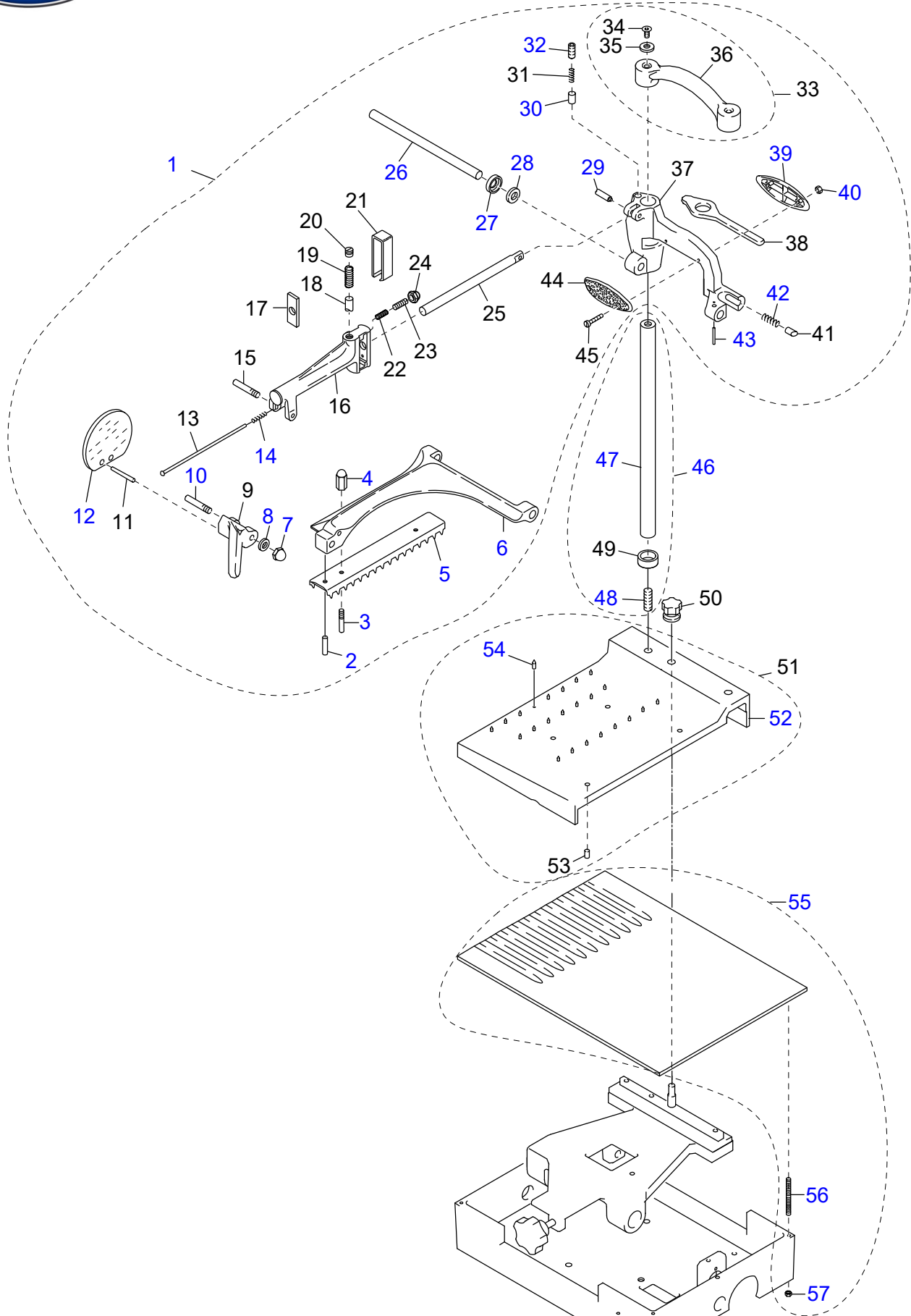



## FS14 Product Tray Components

Item	Part Number	Description	Qty	Serial Number
1	R01662	Arm Assembly	Incl. items 2-45)	1
2		Bumper		1
3		Stud, Threaded		2
4		Acorn Nut, Long		2
5		Grip Plate		1
6		Grip Plate Arm		1
7	H01938	Acorn Nut		1
8	H01898	Washer		4
9		Lever		1
10	H01897	Threaded Rod		1
11		Pin 8mm Tapered		1
12	R01899	Lever Guard		1
13		Rod		1
14		Spring		1
15		Pin		1
16		Lever Arm		1
17		Plate		1
18		Plug, Brass Tension		1
19		Spring		1
20		Set Screw M10x1x10.5mm Hollow		1
21		Cover, Lever Arm		1
22		Spring		1
23		Set Screw M6x1x14mm Hollow		1
24	H01938	Acorn Nut		1
25		Lever Arm Rod		1
26		Arm Rod, Grip Plate		1
27		Spacer		1
28		Bushing		1
29		Pin		1
30		Plug, Brass Tension		1
31		Spring		1
32		Set Screw		1
33	R01663	Pusher Handle Assembly	(Incl. items 34-36)	1
34		Screw		2
35	H01898	Washer		2
36		Handle		1
37		Handle Support		1
38		Pusher Lever		1
39		Grip, Back		1
40		Nut		2
41		Plug, Brass Tension		1
42		Spring		1
43		Pin		1
44		Grip, Front		1
45		Screw M3x0.5mm		2
46	R01665	Slide Rod Assembly	(Incl. items 47-49)	1
47		Slide Rod, Arm		2
48		Set Screw		2
49		Spacer		2
50	R01891	Product Holder Release Knob		1
51	R01667	Sliding Product Holder Assembly	(Incl. items 52-54)	1
52		Holder, Sliding Product		1
53		Set Screw		4



## FS14 Product Tray Components

---

Item	Part Number	Description	Qty	Serial Number
54		Steel Pin	24	
55	R01669	Carriage Base Cover Kit	1	
56		Rod, Threaded	4	
57		Nut	4	



*INTENTIONALLY LEFT BLANK PAGE*



# FS14 Sharpener Assembly Components

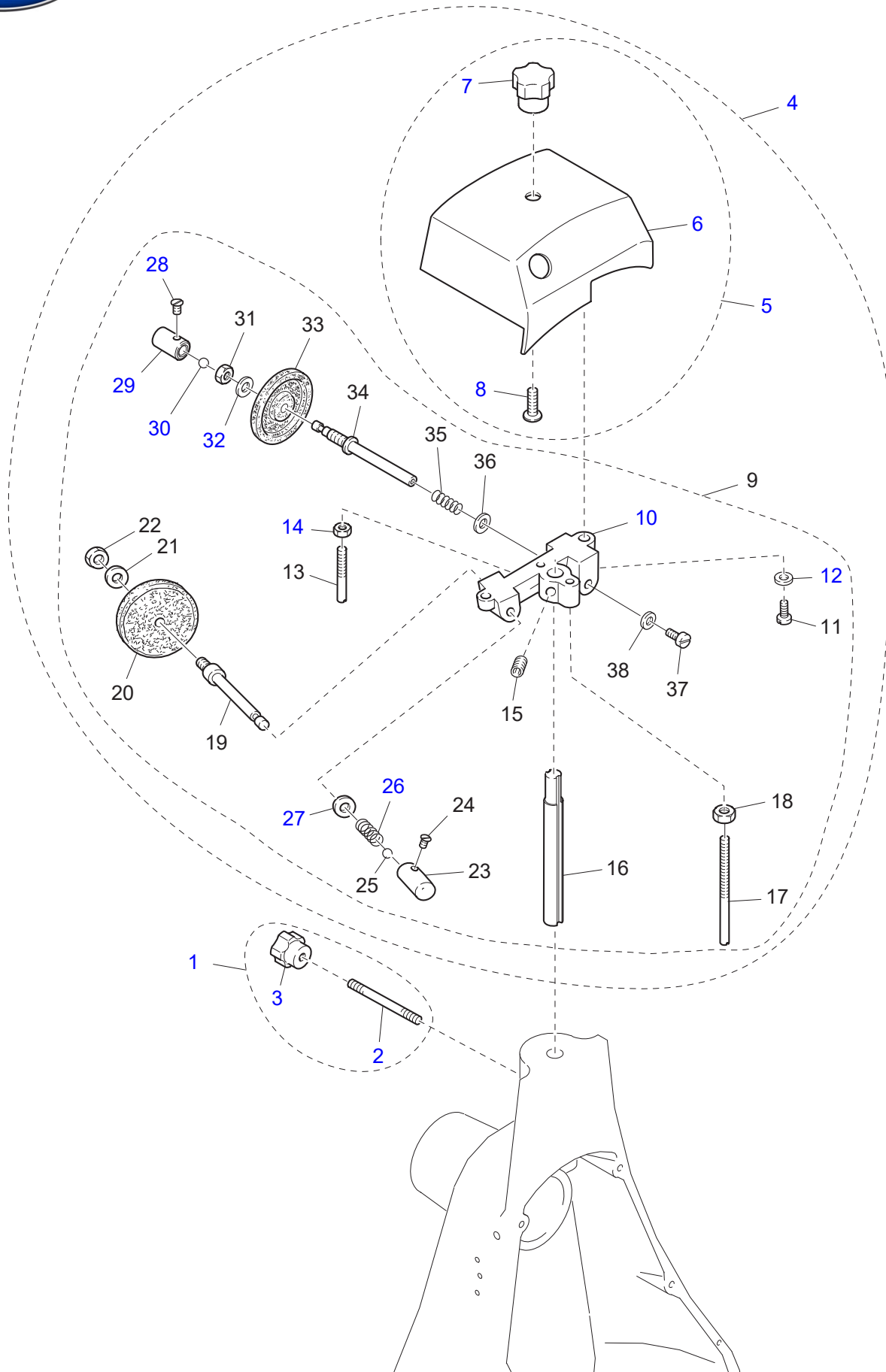



## FS14 Sharpener Assembly Components

Item	Part Number	Description	Qty	Serial Number
1	R01670	Sharpener Release Knob	1	
2		Pin	1	
3		Release Knob, Sharpener	1	
4	R01671	Sharpener Assembly	1	
5	R01673	Sharpener Cover Assembly	1	
6		Cover, Sharpener	1	
7	R01855	Sharpener Cover Knob	1	
8	H01690	Screw M8-1.25x20mm Socket Hd Cap	1	
9	R01672	Sharpener Assembly No Cover	1	
10		Housing, Sharpener	1	
11		Screw M5-0.8x16mm Flat Hd	2	
12	H01861	Washer M4x10OD mm Flat	2	
13		Pin	1	
14	H01682	Nut M5-0.8 Hex	1	
15		Set Screw M6-1.0x8mm Hex Hd	1	
16		Shaft, Sharpener	1	
17		Pin	1	
18	H01682	Nut M5-0.8 Hex	1	
19		Shaft, Sharpener Stone	1	
20	R01854	Sharpening Stone	1	
21		Washer M6x13 OD mm Flat Hd	1	
22		Nut M6-1.0x10mm Hex	1	
23		Push Button, Sharpener	1	
24		Screw 45-1.45x3mm Flat Hd	1	
25		Bearing, Ball	1	
26		Spring	1	
27	H01573	Washer M4x12mm	1	
28		Screw 45-1.45x3mm Flat Hd	1	
29		Push Button, Sharpener	1	
30		Bearing, Ball	1	
31		Nut M6-1.0x10mm Hex	1	
32		Washer M6x13 OD mm Flat Hd	1	
33	R01865	Deburring Stone	1	
34		Shaft, Sharpener Stone	1	
35		Spring	1	
36	H01573	Washer M4x12mm	1	
37		Screw 39-.5x5mm Flat	1	
38		Washer M2.5x60 OD mm Flat	1	