

Model FS12



Model #: _____

Serial #: _____

Date of Purchase: _____



**Instruction Manual for the Flywheel Slicer
Model: FS12**

For all after sales support, visit www.globefoodequip.com

- **Complete the Warranty Registration**
- **Find an Authorized Servicer**
- **View Parts Catalogs**

For additional Technical Support call Globe at 1-866-260-0522.

- IMPORTANT SAFETY NOTICE -

This manual contains important safety instructions which must be strictly followed when using this equipment.

Maintain this manual for reference.

Index

ATTENTION OWNERS AND OPERATORS.....	4
KEY COMPONENTS OF THE SLICER	5
GLOBE SLICER SAFETY TIPS	6
INSTALLATION	7-8
OPERATING INSTRUCTIONS.....	9-12
CLEANING & SANITIZING.....	13-16
KNIFE SHARPENING	17-19
INSPECTIONS, SIMPLE MAINTENANCE AND REPAIR	21-25
TROUBLESHOOTING GUIDE	27
LIMITED SLICER WARRANTY	28



GLOBE FOOD EQUIPMENT CO.
2153 DRYDEN RD.
DAYTON, OH 45439
Toll Free: 800-347-5423
PHONE: 937-299-5493
FAX: 937-299-8623
E-MAIL: info@globefoodequip.com
WEBSITE: www.globefoodequip.com

Attention Owners and Operators

Globe's equipment is designed to provide years of safe and productive processing of food products as long as the equipment is used in accordance with the instructions in this manual and is properly maintained. Importantly, unless the operator is adequately trained and supervised, there is a possibility of serious injury. Owners of this equipment bear the responsibility to make certain that this equipment is used properly and safely. Strictly follow all of the instructions contained in this manual and the requirements of local, state and federal law.

Owners should not permit anyone to touch this equipment unless they are over 18 years of age, are adequately trained and supervised, and have read and understand this manual. Owners should also ensure that no children, customers, visitors or other unauthorized personnel come in contact with this equipment. Please remember that Globe cannot anticipate every circumstance or environment in which its equipment will be operated. It is the responsibility of the owner and the operator to remain alert to any hazards posed by the function of this equipment, particularly the sharp knife blade and all moving parts. If you are ever uncertain about a particular task or the proper method of operating this equipment, ask your supervisor.

To prevent illness caused by the spread of food-borne pathogens, it is important to properly clean and sanitize the entire slicer as any surface of the slicer can become contaminated. It is the responsibility of the slicer owner/operator to follow all guidelines, instructions and laws as established by your local and state health departments and the manufacturers of chemical sanitizers.

When cleaning your slicer, pay particular attention to cracks, broken seams and any area that may collect food debris. If your slicer, or any of its parts, is damaged or broken, it may become more difficult to properly clean and sanitize the unit. If your slicer is damaged or needs repair, contact an experienced service individual immediately to ensure the slicer can be properly sanitized. If you have any questions, please contact Globe at 1-800-347-5423.

This manual offers information to supplement your procedures to improve the sanitization of your machine and contains a Safety Tips section listing a number of precautions to follow to help promote safe use of this equipment. Throughout the manual you will see additional warnings to help alert you to potential hazards.

Warnings affecting your personal safety are indicated by:



or



Warnings related to possible damage to the equipment are indicated by:



A wall chart with safety instructions is included with this equipment. This wall chart should be posted near the slicer within easy view of the operator. You should make certain that this manual is available for easy reference by any operator. Globe has put several warning labels in the English language on the slicer. French and Spanish labels are also available and can replace the English labels at the owner's discretion. If the warning labels, the wall chart, or this manual are misplaced, damaged or illegible, or if you require additional copies, please contact your nearest representative or Globe directly for these items at no charge.

Please remember that this manual, the wall chart and the warning labels do not replace the need to be alert, to properly train and supervise operators, and to use common sense when using this equipment.

Key Components of the Slicer

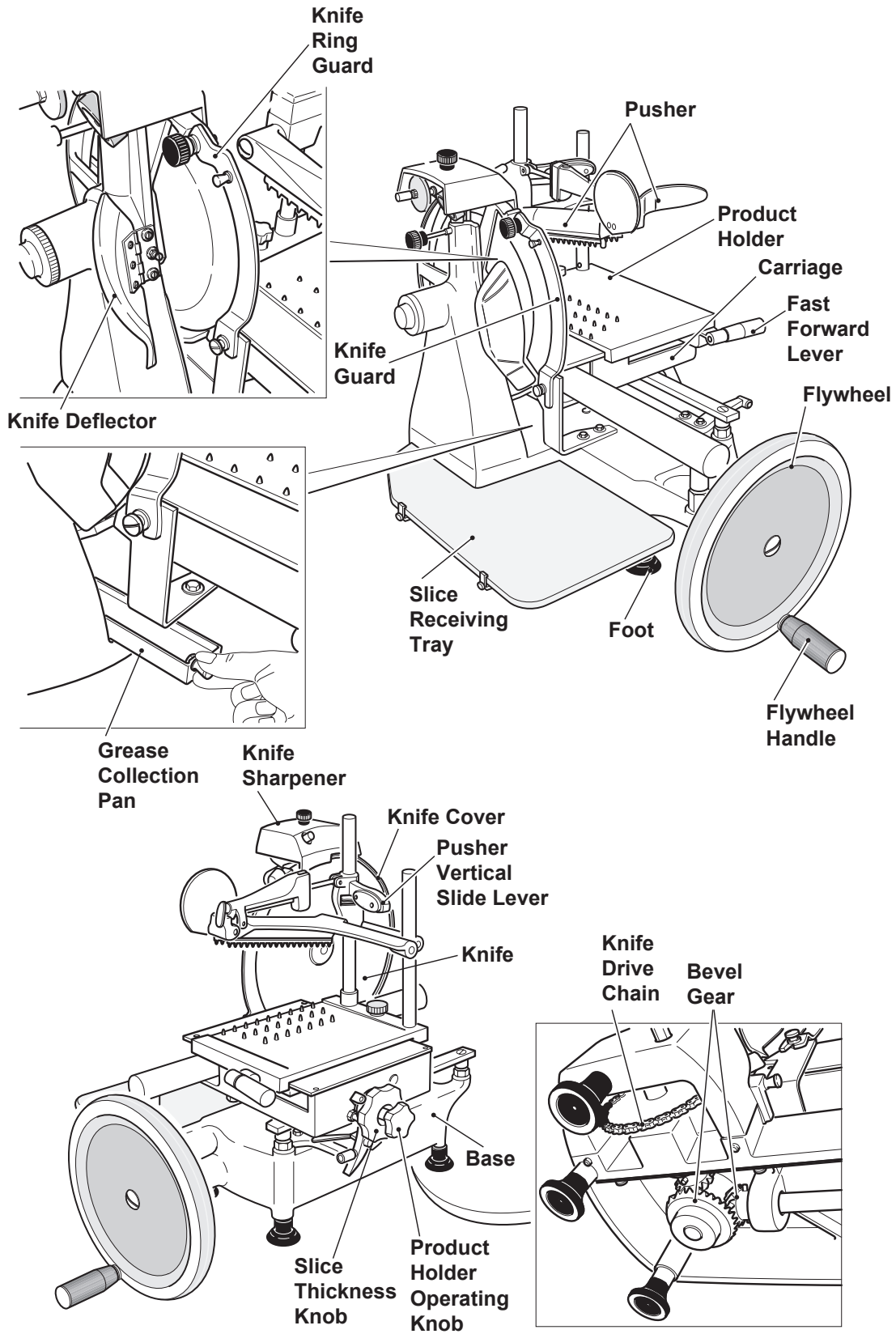

Globe Slicer Safety Tips

 **WARNING**



SHARP KNIFE BLADE

TO AVOID SERIOUS PERSONAL INJURY:

- **NEVER** touch slicer before reading and completely understanding everything in this instruction manual. You must be at least 18 years old and have had proper training and authorization from your supervisor.
- **ONLY** install the slicer on a level nonskid surface that is nonflammable and is located in a clean, well-lit work area away from children and visitors.
- **NEVER TOUCH KNIFE.** Keep hands and arms away from all moving parts, hold only the pusher handle.
- **NEVER OPERATE** slicer without knife cover and knife sharpener securely installed.
- **NEVER HOLD THE FOOD PRODUCT WHILE SLICING.** Hold only the pusher handle to slice.
- **BEFORE CLEANING, SERVICING, OR REMOVING ANY PARTS** always turn the slice thickness control knob counter-clockwise until it stops.
- **ALWAYS** properly clean and sanitize your slicer. To prevent illness or death caused by the spread of food-borne pathogens, it is important to properly clean and sanitize the entire slicer as any surface of the slicer can become contaminated. It is the responsibility of the slicer owner/operator to follow all guidelines, instructions and laws as established by your local and state health departments and the manufacturers of chemical sanitizers.

Installation

UNPACKING

1. Unpack the slicer immediately after receipt. If the machine is found to be damaged, save the packaging material and contact the carrier within fifteen (15) days of delivery and immediately contact your source of the equipment. **You have no recourse for damage after fifteen (15) days of receipt.**
2. With the slicer you should receive: wall chart, lubricating oil and an instruction manual. Contact Globe or your local supplier if you did not receive all of these items.



THIS UNIT IS FOR INDOOR COMMERCIAL USE ONLY.

TO AVOID SERIOUS PERSONAL INJURY PROPERLY INSTALL SLICER IN ADEQUATE WORK AREA

- **ALWAYS** install equipment in a work area with adequate light and space.
 - **ONLY** operate on a solid, level, nonskid surface that is nonflammable.
 - **NEVER** bypass, alter, or modify this equipment in any way from its original condition. Doing so can create hazards and will void warranty.
 - **NEVER** operate slicer without the knife cover and knife sharpener securely installed.
 - **NEVER** operate slicer without the warning labels attached to slicer (see Key Components and Simple Maintenance and Repair sections) and the Globe wall chart posted within view of operator.
3. Read this manual thoroughly before installation and operation. **DO NOT** proceed with installation and operation if you have any questions or if you do not understand everything in the manual. Contact your local representative or Globe first. ***Make sure to clean and sanitize your entire slicer before use. Refer to this manual for cleaning and sanitizing guidelines.***

Installation

INSTALLATION OF SLICER ON THE STAND BASE

USE AT LEAST TWO PEOPLE TO MOVE SLICER TO OPERATING LOCATION. NEVER ATTEMPT TO MOVE SLICER ALONE.

1. Make sure stand base is level and that all three feet are correctly level on the ground (Figure 8-1).

MAKE SURE ALL SLICER FEET ARE POSITIONED ON TOP OF THE STAND BASE. NO PART OF THE SLICER FEET SHOULD HANG OVER STAND BASE.

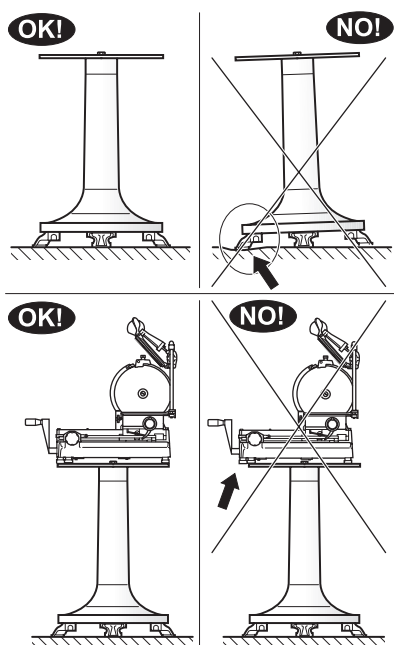

Figure 8-1

STAND BASE CAN BECOME TOP HEAVY ONCE SLICER IS INSTALLED. WHEN MOVING THE STAND BASE, MAKE SURE TO ONLY MOVE ON A SMOOTH, EVEN SURFACE.

2. Carefully lift the slicer and position on the stand base.
3. Remove the plastic bag from slicer.
4. Inspect slicer to make sure all parts have been provided.
5. Make sure knife cover and knife sharpener are in place.
6. Make sure warning labels are properly positioned and legible and the instruction manual is available near slicer.
7. Complete warranty registration online at www.globefoodequip.com/support/warranty-registration-form.
8. Post the provided wall chart in a visible area near slicer. Refer to the wall chart and the Owner's Manual for proper cleaning, sanitizing and inspection of the slicer.

9. Refer to the procedures outlined in Cleaning & Sanitizing section to clean the slicer before use.
10. Contact your local representative, or Globe directly, if you have questions or problems with the installation or operation of the slicer.

INSTALLATION OF SLICER WITHOUT THE STAND BASE

1. Select a location for the slicer that has a level, solid, nonskid surface that is nonflammable and is in a well-lit work area that is away from children and visitors (Figure 8-2).

USE AT LEAST TWO PEOPLE TO MOVE SLICER TO OPERATING LOCATION. NEVER ATTEMPT TO MOVE SLICER ALONE.

2. Carefully move the slicer and position on a level, solid, nonskid surface.
3. Remove the plastic bag from slicer.
4. Inspect slicer to make sure all parts have been provided.
5. Make sure knife cover and knife sharpener are in place.
6. Make sure warning labels are properly positioned and legible and the instruction manual is available near slicer.
7. Complete warranty registration online at www.globefoodequip.com/support/warranty-registration-form.
8. Post the provided wall chart in a visible area near slicer. Refer to the wall chart and the Owner's Manual for proper cleaning, sanitizing and inspection of the slicer.
9. Refer to the procedures outlined in Cleaning & Sanitizing section to clean the slicer before use.
10. Contact your local representative, or Globe directly, if you have questions or problems with the installation or operation of the slicer.

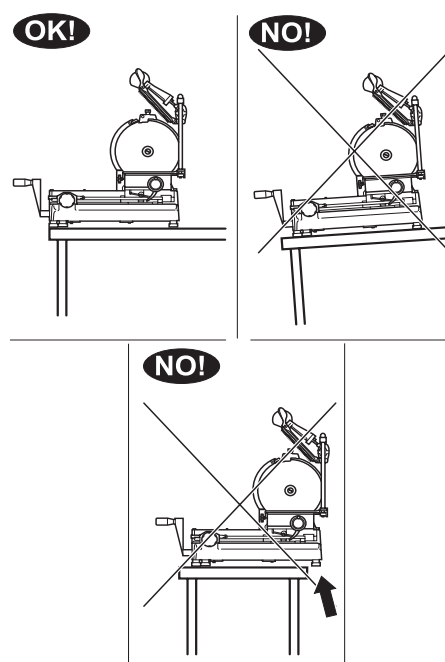

Figure 8-2

Operating Instructions

⚠️ WARNING



SHARP KNIFE BLADE

TO AVOID SERIOUS PERSONAL INJURY:

- **NEVER** touch slicer before reading and completely understanding everything in this instruction manual. You must be at least 18 years old and have had proper training and authorization from your supervisor.
- **ONLY** install slicer on a level nonskid surface that is nonflammable and is located in a clean, well-lit work area away from children and visitors.
- **NEVER TOUCH KNIFE.** Keep hands and arms away from all moving parts, hold only the food pusher.
- **NEVER OPERATE** slicer without knife cover and knife sharpener securely installed.
- **NEVER HOLD FOOD PRODUCT WHILE SLICING.** Hold only the pusher to slice.
- **DO NOT CATCH SLICES WITH YOUR HAND.** Let slices drop onto the receiving area.
- **BEFORE CLEANING, SERVICING, OR REMOVING ANY PARTS** always turn slice thickness knob counter-clockwise until it stops.

PLACE PRODUCT ON PRODUCT HOLDER



Do not slice frozen food or food with bones (meat and fish). Damage to slicer can occur.

1. Turn the flywheel handle (6) clockwise in order to move the carriage (5) to its forward position (towards the operator) (Figure 9-1).

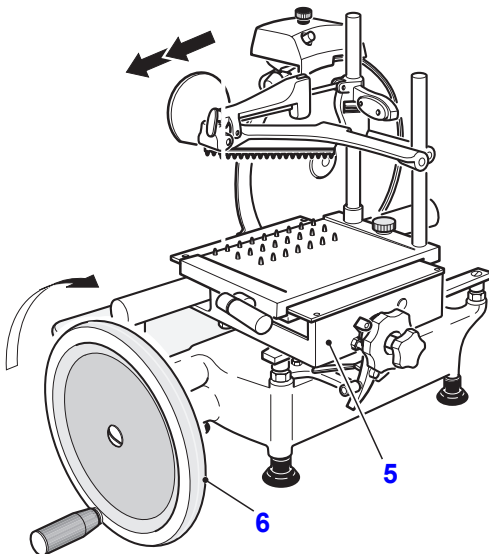

Figure 9-1

2. Turn the product holder operating handwheel (12) clockwise or gently press down on the fast forward lever (11) to move the product holder (4) away from the knife (Figure 9-2).

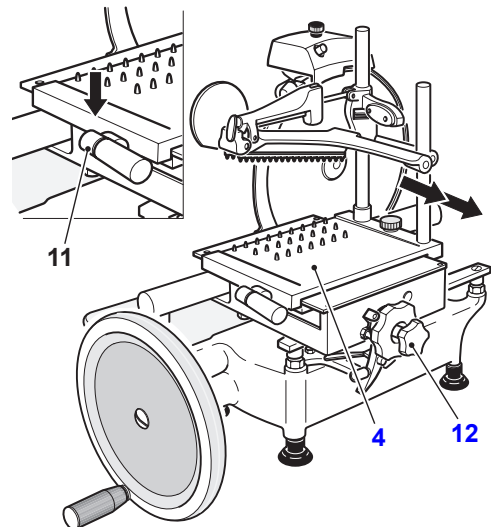

Figure 9-2

Operating Instructions

- Position the food product to be sliced on the product holder (4).
- Use the pusher vertical slide lever (10) to adjust the pusher (3) to hold product in place (Figure 10-1).

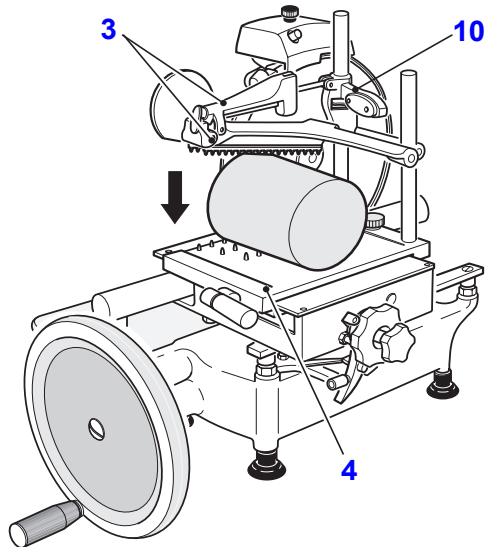

Figure 10-1



Failure to hold the food product firmly in place on the product holder with the pusher could cause the machine to cut uneven slices.

- Pull the slice thickness control dial (13) out towards operator and turn clockwise to the desired setting (Figure 10-2).

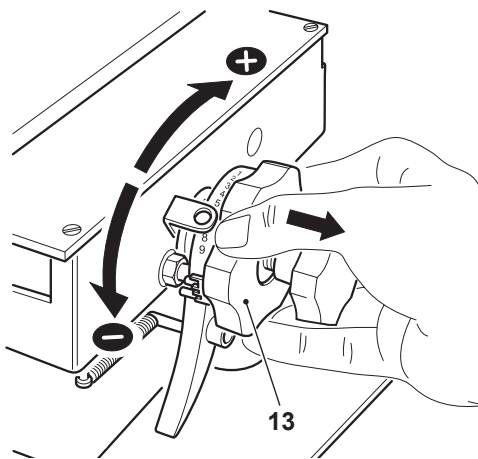

Figure 10-2

- Turn the product holder operating handwheel (12) counterclockwise or gently press down on the fast forward lever (11) to move the product holder (4) towards the knife (Figure 10-3.)



Leave a space between the product to be sliced and the knife blade between 0.5 cm and 1.0 cm.

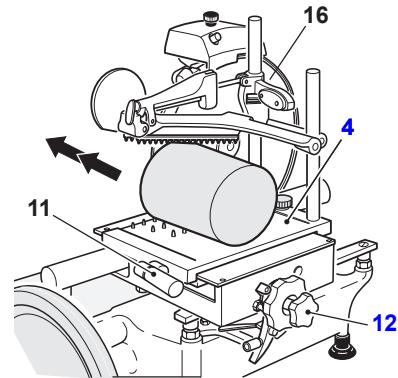

Figure 10-3

SLICING THE FOOD PRODUCT



BE ALERT. The next step will expose the knife.

- Loosen, but do not remove the top and bottom knobs (9a) on the knife guard (9) (Figure 10-4).
- Use the knife guard thumb screw (9b) to lift the knife guard (9) up and to the left of the top and bottom knife guard spacers (9c).
- Tighten the top and bottom knobs (9a) on the knife guard (9).

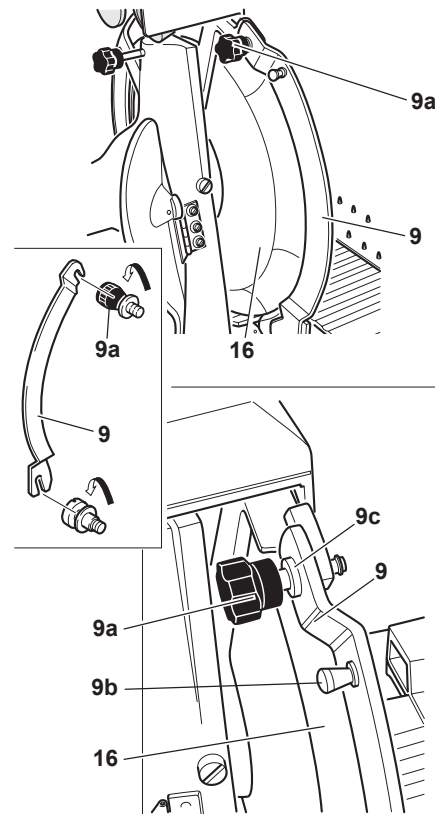

Figure 10-4

Operating Instructions

4. Hold the handle (6) to turn the flywheel (7) clockwise in order to begin knife (16) rotation and movement of the product holder (4) (Figure 11-1).



DO NOT turn the flywheel (7) counter-clockwise. Serious damage to the slicer can occur.

5. Turn the flywheel handle (6) 4 to 5 times in order for the food product to touch the knife (16).

Note: The carriage (5) moves forward (away from the operator), the knife (16) slices the product. Guided by the slice deflector (2), the slice is detached and drops onto the slice receiving tray (1).

Note: As the carriage (5) returns (towards the operator), a mechanical device is operated that moves the product holder (4) sideways towards the knife (16).

6. Use the slice thickness knob (13) to set the amount of sideways movement.

7. Once slicing is complete, stop turning the flywheel handle (6) to stop the knife (16) rotation.

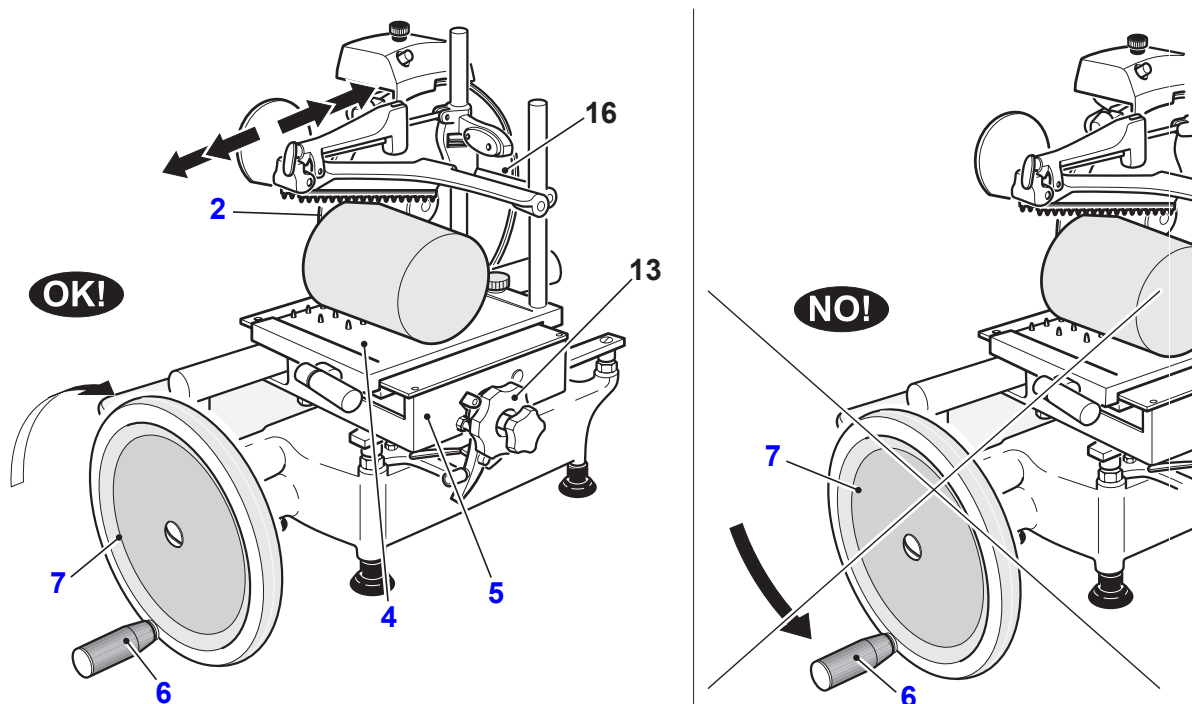

Figure 11-1

Operating Instructions

- Turn the product holder operating handwheel (12) clockwise or gently press down on the fast forward lever (11) to move the product holder (4) away from the knife (16) (Figure 12-1).

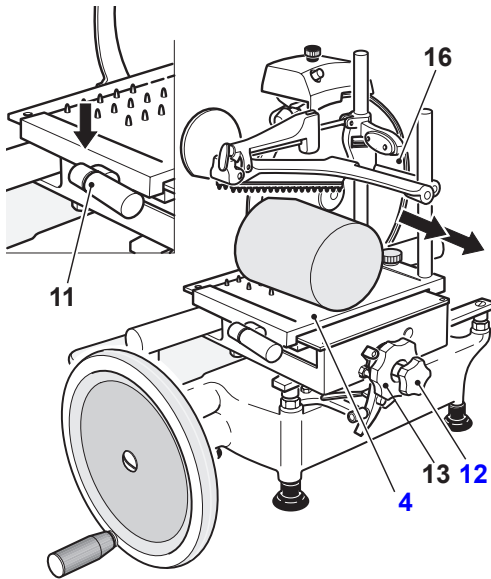

Figure 12-1

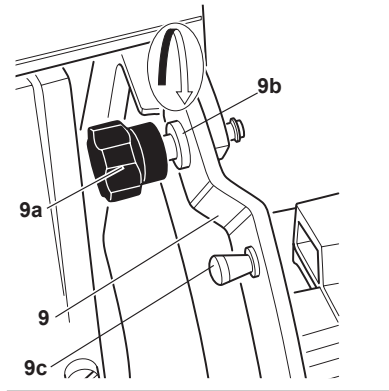

Figure 12-2

- Pull the slice thickness knob (13) out towards operator and turn counter-clockwise to zero (0) until it stops.

- Press the pusher vertical slide lever (10) and lift the pusher (3) to remove the food product from the holder (4) (Figure 12-3).



BE ALERT. The next step will expose knife.

- Close the knife guard (9). Loosen, but do not remove, the top and bottom knobs (9a) on the knife guard (9) (Figure 12-2).
- Use the knife guard thumb screw (9c) to lift the knife guard up and to the right of the top and bottom knife guard spacers (9b).
- Tighten the top and bottom knobs (9a) on the knife guard (9).



Do not leave the slicer without the knife guard (9) closed. Serious personal injury can occur.

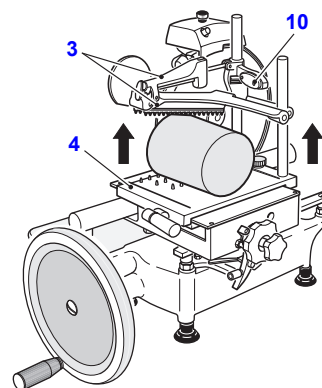
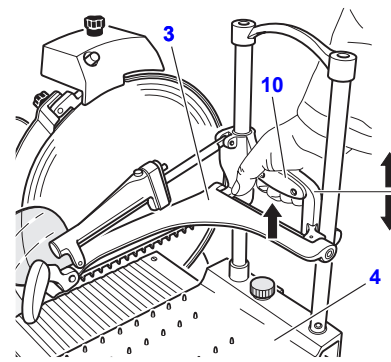

Figure 12-3

Cleaning & Sanitizing

⚠ WARNING



SHARP KNIFE BLADE

TO AVOID SERIOUS PERSONAL INJURY TO THE SLICER OPERATOR AND CUSTOMERS:

- **NEVER** touch slicer before reading and completely understanding everything in this instruction manual. You must be at least 18 years old and have had proper training and authorization from your supervisor.
- **BEFORE CLEANING, SERVICING OR REMOVING ANY PARTS**, turn slice thickness knob counter-clockwise until it stops.
- **NEVER** attempt to remove knife or knife ring guard from slicer. They must remain on slicer for proper operation, sharpening and cleaning.

⚠ WARNING

To prevent illness or death caused by the spread of food-borne pathogens, it is important to properly clean and sanitize the entire slicer as any surface of the slicer can become contaminated. It is the responsibility of the slicer owner/operator to follow all guidelines, instructions and laws as established by your local and state health departments and the manufacturers of chemical sanitizers.



Once your slicer makes contact with food product, the entire slicer, including removable parts, must be thoroughly cleaned and sanitized. This process is to be repeated at least every 4 hours using these procedures and information; and must comply with additional laws from your state and local health departments.



As with all food contact surfaces, it is extremely important to properly sanitize the entire slicer and to closely follow the instructions on your quaternary sanitizer container to make sure proper sanitation is achieved to kill potentially harmful bacteria.

Note: It may be desirable to wear non-cutting safety gloves during the cleaning operation.

IMPORTANT: If a chemical sanitizer other than chlorine, iodine or quaternary ammonium is used, it must be applied in accordance with the EPA-registered label use instructions. Excessive amounts of sanitizer and use of products not formulated for stainless steel or aluminum may VOID your warranty.

Sanitizer concentration must comply with section 4-501.114, Manual and Mechanical Warewashing Equipment, Chemical Sanitization - Temperature, pH, Concentration, and Hardness of the FDA Food Code.

For more information on proper kitchen and equipment sanitation, visit www.servsafe.com provided by the National Restaurant Association (NRA).

⚠ CAUTION

- **DO NOT** hose down, pressure wash or pour water on slicer.
- **NEVER** use a scrubber pad, steel wool or abrasive material to clean slicer.
- **It is extremely important to follow the instructions on the sanitizer container to make sure** proper sanitation is achieved. Allow the parts to air dry before placing them back on slicer!

DO NOT use bleach, products containing sodium hypochlorite or other caustic/strong detergents on slicer base or removable parts. These products will discolor and destroy the parts.

Slicer components are easily disassembled without the use of special tools. It may be desirable to wear non-cutting safety gloves during the cleaning operation.

Cleaning & Sanitizing

DISASSEMBLY & CLEANING

1. Remove the grease collection pan (18) (Figure 14-1).

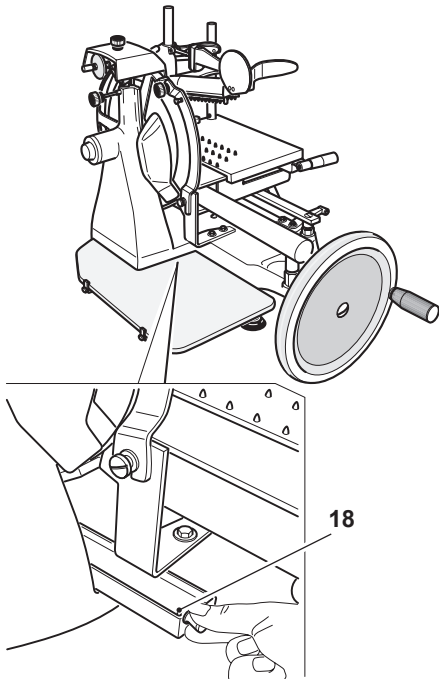

Figure 14-1

2. Unscrew knob (34) to remove the product holder (4) complete with pusher (3) (Figure 14-2).

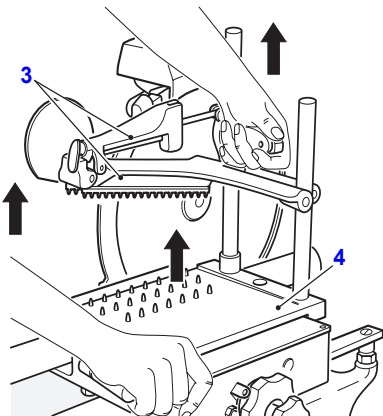
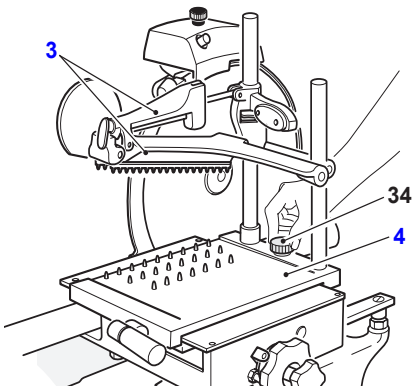



Figure 14-2

3. Place all removable parts in a three compartment sink with warm water and a mild detergent solution; soak, clean, and thoroughly scrub all surfaces using a solution of mild detergent and warm water. Removable parts include: product holder, pusher, slice receiving tray and knife sharpener. Use a soft spongy cloth and, if necessary, a nylon brush for the spiked areas of the product holder (4) and pusher (3).

4. Rinse in hot water only and dry with soft spongy cloths.

 ALWAYS clean the knife (16) with the knife guard (9) fitted behind it in the safety position (Figure 14-3).

5. Carefully wash and rinse the top and bottom of knife (16) by wiping from the center of knife outward.

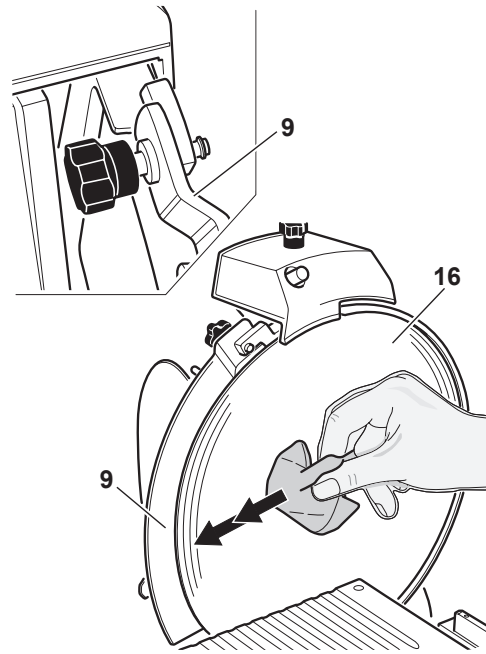

Figure 14-3

6. Soak a cloth in mild detergent and warm water solution.

Cleaning & Sanitizing

- Carefully insert the cloth between the knife (16) and knife ring guard (14). While holding the cloth between knife (16) and knife ring guard (14), work it along the inside surface of ring guard (14). Repeat this procedure as necessary (Figure 15-1).

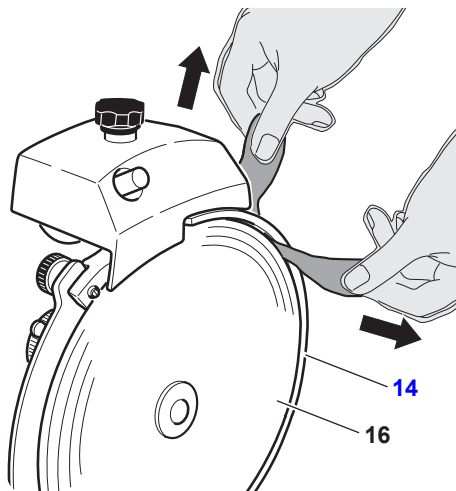

Figure 15-1

- Remove the slice receiving tray (1). Loosen two screws (1a) to release slice receiving surface (1) from the retaining clips (1b) (Figure 15-2).
- Wash the slice receiving tray (1) with warm water and normal dishwashing detergent.

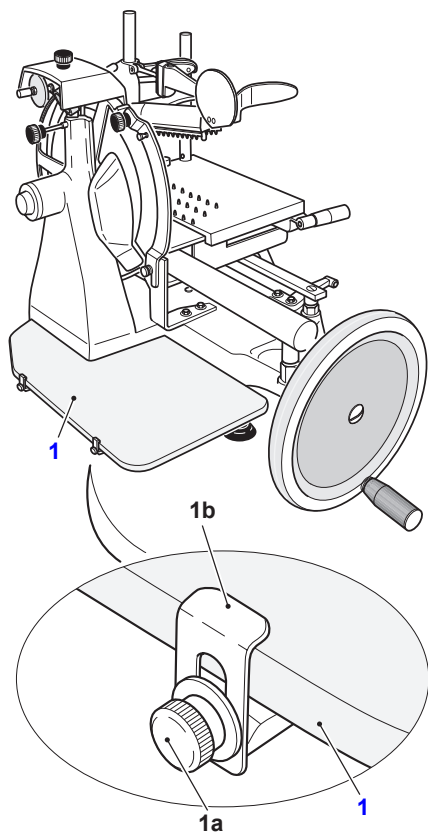

Figure 15-2

REINSTALL REMOVABLE PARTS

- Reposition the product holder (4).
- Place the product holder (4) complete with pusher (3) on the carriage (5) (Figure 15-3).

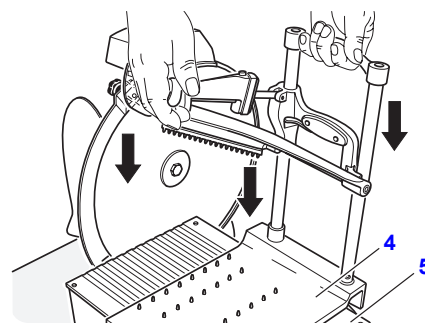

Figure 15-3

- Tighten knob (34) on product holder (4) to secure product holder and pusher (3) to carriage (5) (Figure 15-4).

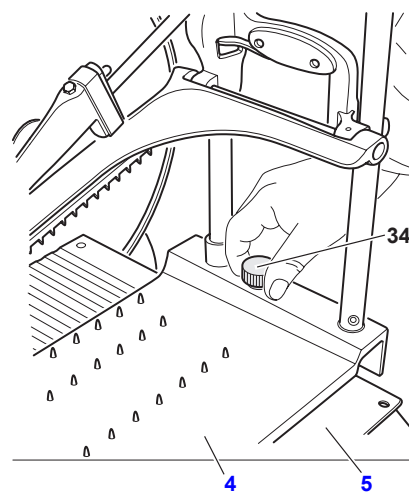

Figure 15-4

Cleaning & Sanitizing

4. Install the slice receiving tray (1). Tighten two screws (1a) that fasten the slice receiving tray (1) to the retaining clips (1b). (Figure 16-1).

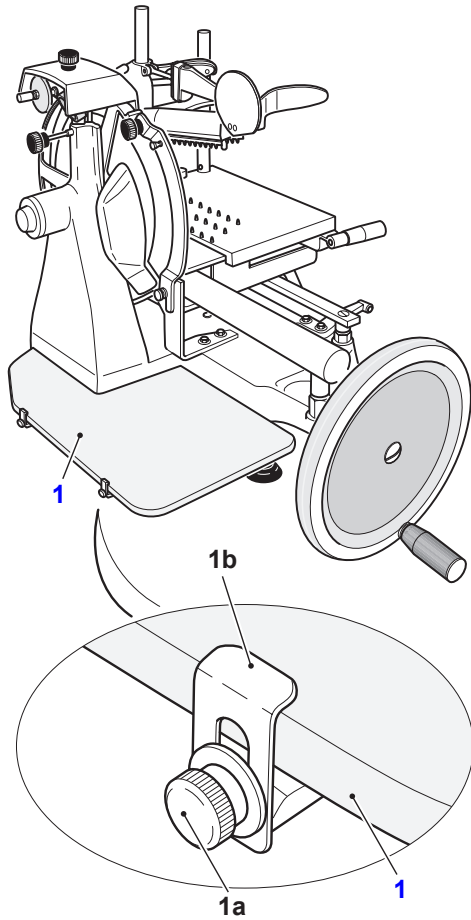

Figure 18-1

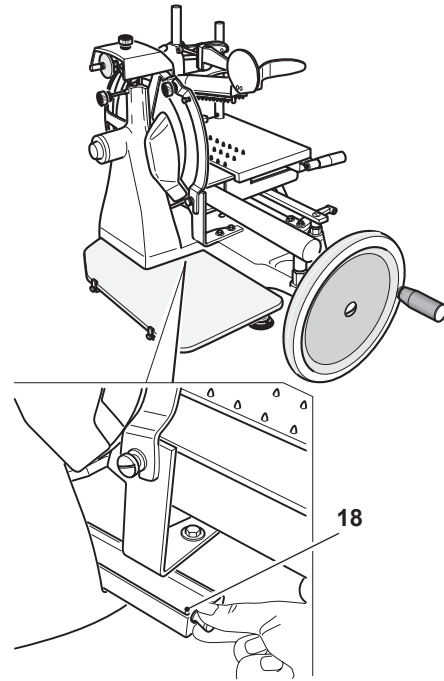

Figure 18-2

5. Install the grease collection pan (18) (Figure 16-2).

Knife Sharpening

WARNING



SHARP KNIFE BLADE

TO AVOID SERIOUS PERSONAL INJURY:

- **NEVER** touch slicer before reading and completely understanding everything in this instruction manual. You must be at least 18 years old and have had proper training and authorization from your supervisor.
- **NEVER** touch rotating knife.
- **ALWAYS** keep hands clear of all moving parts.
- **ALWAYS** turn slice thickness knob counter-clockwise until it stops and pull product holder completely towards you before sharpening.
- **NEVER** sharpen knife unless knife cover is installed.

WHEN AND HOW OFTEN TO SHARPEN KNIFE

1. Indications of a dull knife are excess waste (or “tail”) on the unsliced portion remaining in pusher.
2. The knife needs to be sharpened periodically to provide consistent slices and maximum food product yield. Sharpening knife lightly every few days is more effective than heavy sharpening at less frequent intervals.

PREPARING TO SHARPEN

1. Pull the slice thickness control dial (13) out towards operator and turn counter-clockwise to set to “0” (Figure 19-1).

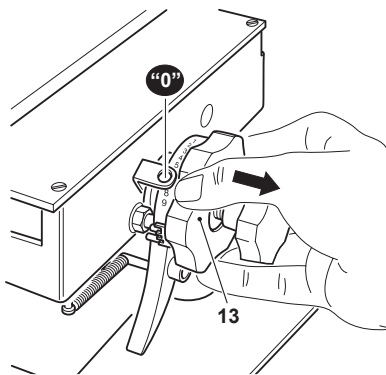



Figure 19-1

2. Clean and dry both sides of knife before sharpening. Refer to Cleaning & Sanitizing section.

 **ALWAYS** sharpen with the knife guard (9) securely in place.

3. Close the knife guard (9). Loosen, but do not remove, the top and bottom knobs (9a) on the knife guard (9) (Figure 17-2).
4. Use the knife guard thumb screw (9c) to lift the knife guard up and to the right of the top and bottom knife guard spacers (9b).

5. Tighten the top and bottom knobs (9a) on the knife guard (9).

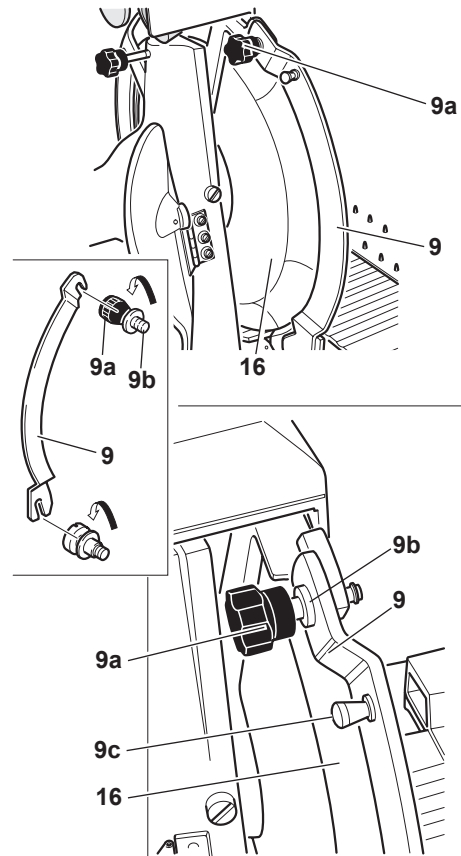

Figure 19-2

Knife Sharpening

6. Turn the product holder operating handwheel (12) clockwise or gently press down on the fast forward lever (11) to move the product holder (4) away from the knife (16) (Figure 18-1).

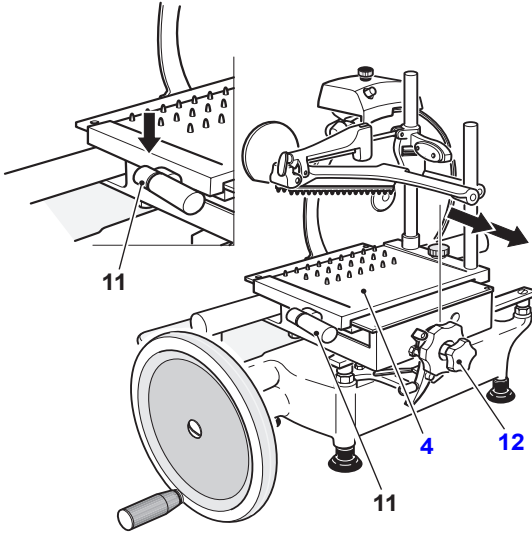

Figure 18-1

7. Loosen the knife sharpener knob (38) holding the knife sharpener (17) in place (Figure 18-2).
8. Lift the knife sharpener (17) and turn 180° (Figure 18-3).
9. Carefully lower the knife sharpener (17). The knife (16) will automatically be centered between the two grinding wheels (Figure 18-4).
10. Tighten the knife sharpener knob (38) (Figure 18-5).

Figure 18-2

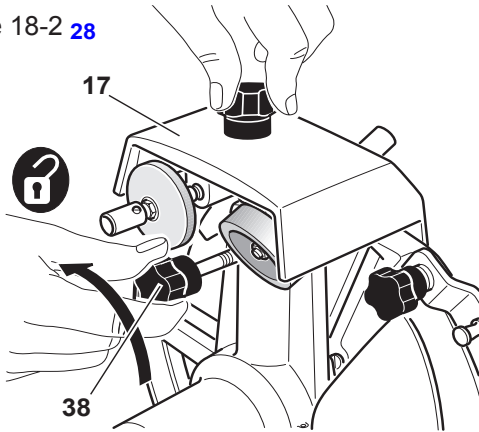

Figure 18-3

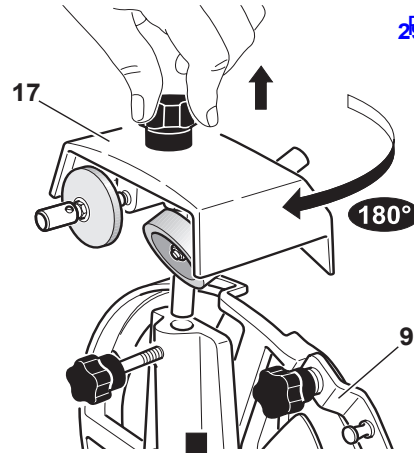

Figure 18-4

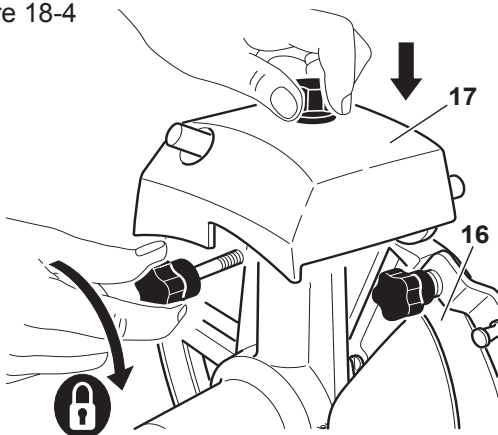
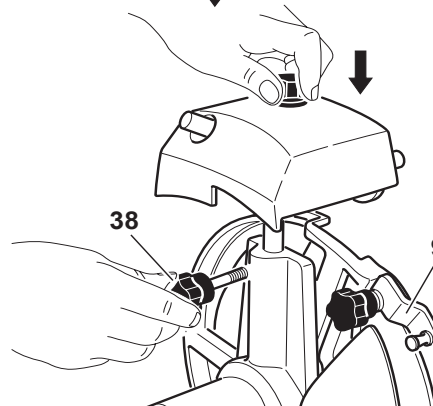

Figure 18-5



Knife Sharpening

11. Turn the flywheel handle (6) clockwise and press the "X" button. Perform about 20 to 30 knife revolutions (Figure 19-1).
12. Stop turning the flywheel handle (6) to stop the knife rotation. Use a pencil to check that a slight burr has formed on the knife edge.
13. Turn the flywheel handle (6) clockwise and press the "K" button.



Do not exceed 1 or 2 knife revolutions in order to prevent the knife edge from springing back, creating a reverse burr.

14. Return the sharpener to its original position.

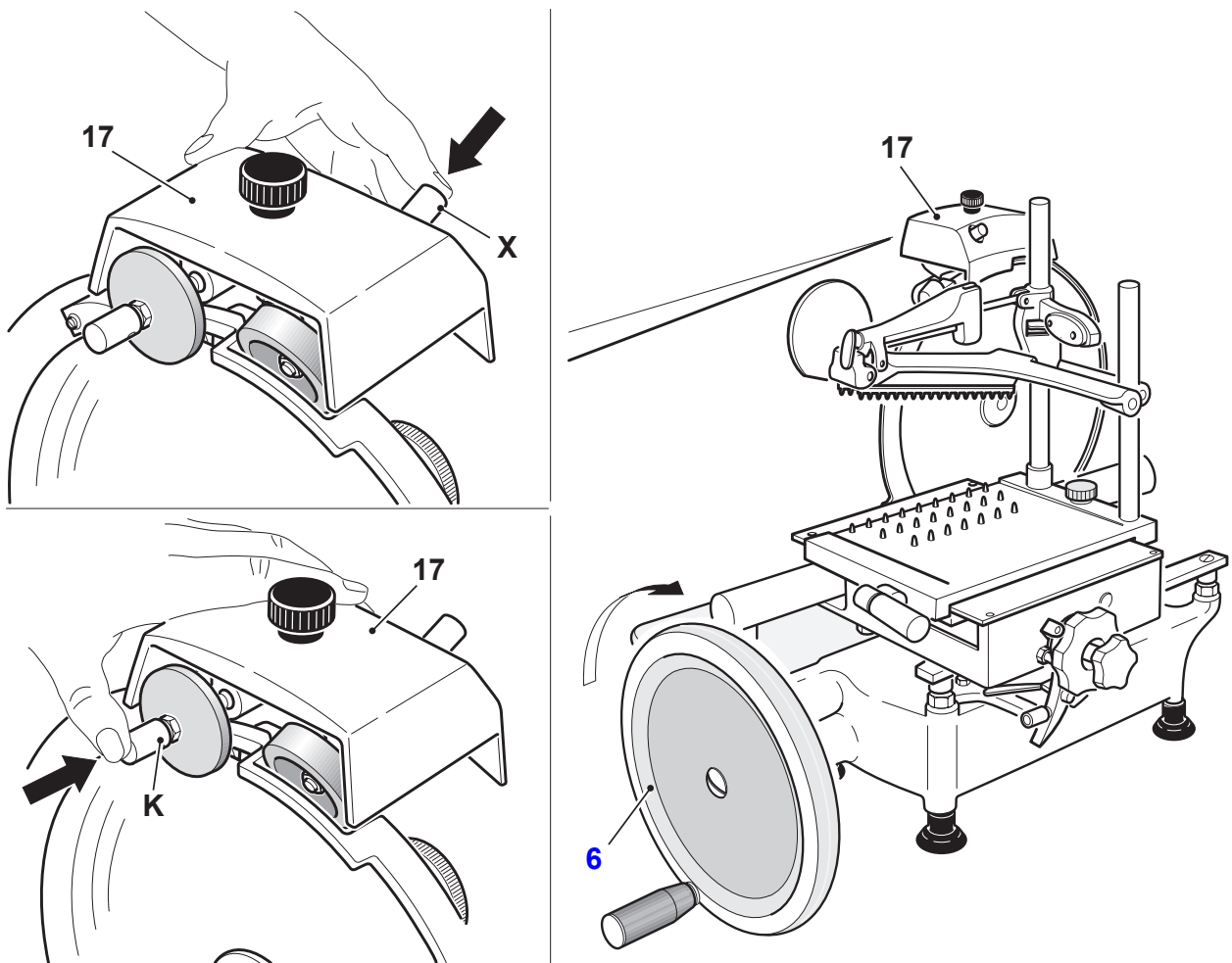

Figure 19-1

Intentionally Left Blank

Inspections, Simple Maintenance, and Repair

⚠ WARNING



SHARP KNIFE BLADE TO AVOID SERIOUS PERSONAL INJURY:

- **NEVER** touch slicer before reading and completely understanding everything in this instruction manual. You must be at least 18 years old and have had proper training and authorization from your supervisor.
- **BEFORE CLEANING, SERVICING, OR REMOVING ANY PARTS** always turn slice thickness knob counter-clockwise to zero (0) until it stops.
- **NEVER TOUCH KNIFE.** Keep hands and arms away from all moving parts.
- **DO NOT** tamper with, bypass or remove any safety devices or guards.
- **AFTER EACH USE, ALWAYS** turn the slice thickness knob counter-clockwise to zero (0) until it stops.
- **USE ONLY GLOBE PARTS AND ACCESSORIES** properly installed.

INSPECTING THE SLICER

INSPECT THE SLICER FOR DAMAGED OR BROKEN PARTS. A thorough visual inspection should be made of the entire slicer and its parts. Globe urges the owner/operator to inspect all components often and for an authorized service agent to inspect the entire slicer at least every 6 months, including all parts that are detachable for cleaning and sanitizing. This inspection should include looking for damaged parts and areas that may be more difficult to clean and sanitize.

⚠ WARNING

IF DAMAGE IS FOUND OR PARTS ARE MISSING, THE SLICER MUST BE REMOVED FROM SERVICE UNTIL IT IS REPAIRED BY AN AUTHORIZED SERVICER.

Inspections, Simple Maintenance, and Repair

LUBRICATION

Various slicer parts need to be lubricated periodically using Globe oil. Globe oil is a light, tasteless, odorless mineral oil that will not contaminate or impart odors or taste to sliced food products.



DO NOT USE VEGETABLE OIL TO LUBRICATE SLICER. VEGETABLE OIL WILL DAMAGE THE SLICER.

Oil carriage guide rail, product holder and lubrication points.

1. Once a week, apply 2 to 3 drops of lubricant to the carriage (5) guide rail (Figure 22-1).
2. Use the product holder operating handwheel (12) to slide the carriage (5) back and forth 3 to 4 times.
3. Apply 2 to 3 drops of lubricant to the product holder (4).
4. Turn the product holder operating handle (12) or gently press down on the fast forward lever (11) to move the product holder (4) back and forth 3 to 4 times.
5. Apply 2 to 3 drops of lubricant to the guide rails (36).
6. Turn the flywheel handle (6) clockwise 3 or 4 times to move the product holder (4) back and forth in order to lubricate the guide rails.
7. Wipe excess lubricant with a paper towel.

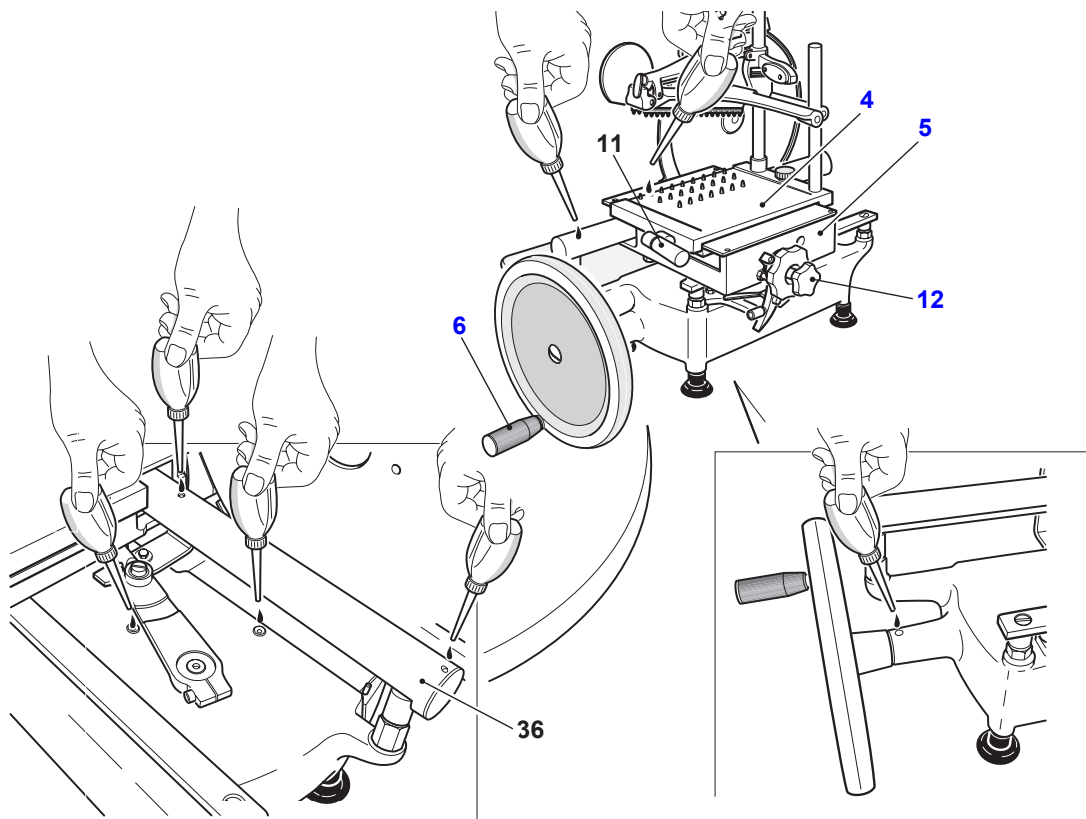

Figure 22-1

Inspections, Simple Maintenance, and Repair

8. Apply 2 to 3 drops of lubricant to the pusher (10) of the pusher's (3) vertically sliding lever (Figure 23-1).
9. Press the pusher level (10) to slide the pusher (3) up and down 3 to 4 times.
10. Wipe excess lubricant with a paper towel.

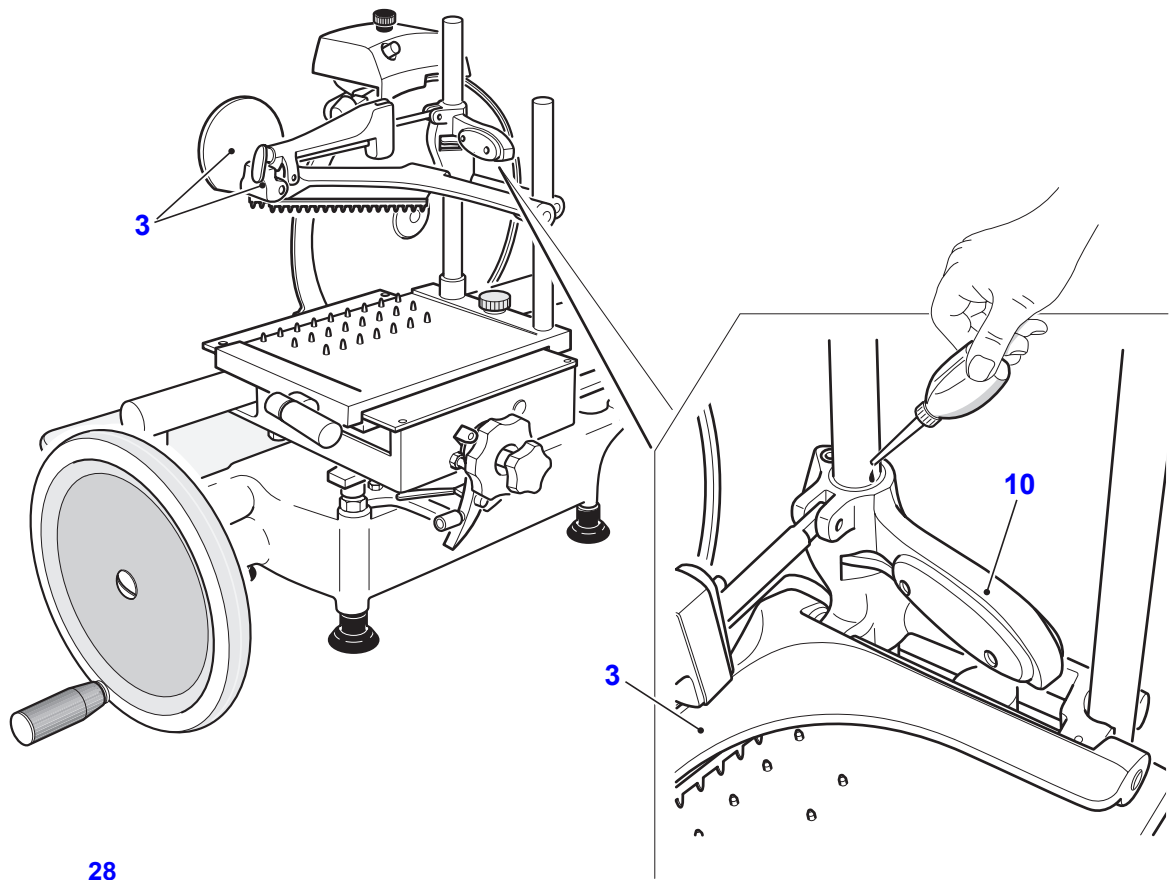

Figure 23-1

Intentionally Left Blank

Inspections, Simple Maintenance, and Repair

Oil Chain.

Every 6 months proceed as follows:

1. Lift the slicer and apply 3 to 4 drops of the supplied lubricant to the oil chain (19) and bevel gears (20) (Figure 25-1).



Do not use vegetable oil.

2. Wipe excess lubricant with a paper towel.

Knife Sharpening.

1. Sharpen the knife (16) periodically or at least once every 6 months as described in Knife Sharpening.

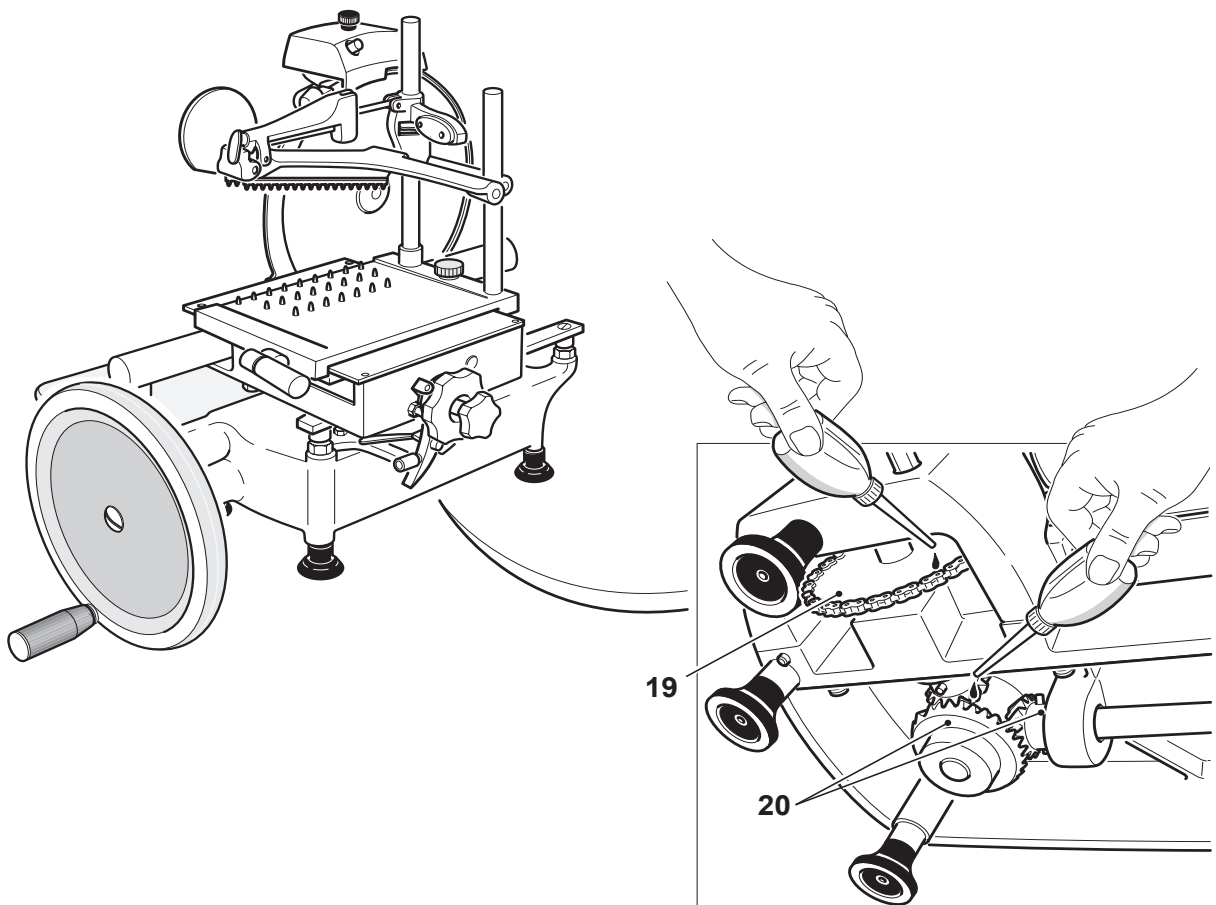

Figure 25-1

Intentionally Left Blank

Troubleshooting Guide

PROBLEM	CAUSE	SOLUTION
Difficulty in slicing; excessive resistance when the product is in contact with the knife.	Dull Knife.	Sharpen the knife.
	Product is overly mature or too dry.	Tenderize product before slicing.
	Slicing begins with product in contact with the knife.	Turn the flywheel handle 4 to 5 times before the product touches the knife.
Slices are of irregular thickness.	The pusher fails to secure the product correctly.	Reposition the pusher in order to secure the product correctly.
	Dull Knife.	Sharpen the knife.
Ragged cuts, poor yield.	The pusher fails to secure the product correctly.	Reposition the pusher in order to secure the product correctly.
	Dull Knife.	Sharpen or have new knife installed
Slices are empty in the middle.	The product is too soft (not mature enough).	Press the pusher harder.
	Dull Knife.	Sharpen the knife.
Slices disintegrate into several pieces; they are not sliced cleanly.	Dull Knife.	Sharpen the knife.
	Knife too small	Replace the knife.

If problems persist and the assigned solution does not remedy the issue, please call our Service Department at 866-260-0522.

Limited Slicer Warranty

Globe Food Equipment Company (“GFE”) warrants to the original purchaser of new equipment that said equipment, when installed in accordance with our instructions within North America and subjected to normal use, is free from defects in material or workmanship for a period of two years on parts with a lifetime guarantee on stones in the sharpening system. The labor warranty is one year from installation or 18 months from actual shipment date, whichever date occurs first.

THIS WARRANTY IS IN LIEU OF ALL OTHER WARRANTIES, WHETHER EXPRESSED OR IMPLIED. GFE EXPRESSLY DISCLAIMS ANY IMPLIED WARRANTY OF MERCHANTABILITY OR EXPRESSED OR IMPLIED WARRANTY OF FITNESS FOR A PARTICULAR PURPOSE.

GFE’S OBLIGATION AND LIABILITY UNDER THIS WARRANTY IS EXPRESSLY LIMITED TO REPAIRING AND REPLACING EQUIPMENT WHICH PROVES TO BE DEFECTIVE IN MATERIAL OR WORKMANSHIP WITHIN THE APPLICABLE WARRANTY PERIOD. All repairs pursuant to this Warranty will be performed by an Authorized Designated GFE Service Location during normal working hours. IN NO EVENT SHALL GFE BE LIABLE FOR INCIDENTAL OR CONSEQUENTIAL DAMAGES TO BUYER OR ANY THIRD PARTY, INCLUDING, WITHOUT LIMITATION, LOSS OF PROPERTY, PERSONAL INJURY, LOSS OF BUSINESS OR PROFITS OR OTHER ECONOMIC LOSSES, OR STATUTORY OR EXEMPLARY DAMAGES, WHETHER IN NEGLIGENCE, WARRANTY, STRICT LIABILITY OR OTHERWISE.

This warranty is given only to the first purchaser from a retail dealer. No warranty is given to subsequent transferees.

This warranty does not cover product failures caused by: failure to maintain, neglect, abuse, damage due to excess water, fire, normal wear, improper set up and use. Periodic maintenance including lubrication and sharpening are not covered.

This Warranty is not in force until such time as a properly completed, digitally signed, Installation/Warranty Registration has been received by GFE within 30 days from the date of installation. Complete warranty registration at: www.globefoodequip.com/support/warranty-registration-form.

Example of items not covered under warranty, but not limited to just these items:

1. Acts of God, fire, water damage, burglary, accident, theft, vandalism.
2. Freight damage.
3. Improper installation or alteration of equipment.
4. Use of generic or after market parts.
5. Repairs made by anyone other than a GFE designated servicer.
6. Lubrication.
7. Expendable wear parts, knife, rubber boots, blown fuses, lamps.
8. Cleaning of equipment.
9. Misuse or abuse.

THE FOREGOING WARRANTY PROVISIONS ARE A COMPLETE AND EXCLUSIVE STATEMENT BETWEEN THE BUYER AND SELLER. GFE NEITHER ASSUMES NOR AUTHORIZES ANY PERSONS TO ASSUME FOR IT ANY OTHER OBLIGATION OR LIABILITY IN CONNECTION WITH SAID EQUIPMENT.

WARRANTY REGISTRATION
GO TO WWW.GLOBEFOODEQUIP.COM
TO FILL OUT AND SUBMIT YOUR WARRANTY REGISTRATION.

WWW.GLOBEFOODEQUIP.COM/SUPPORT/WARRANTY-REGISTRATION-FORM