

Parts Catalog



E220

Slicing Machine

Model: E220

05/22/2023 Rev B

IMPORTANT!

TO EXPEDITE SHIPMENT OF PARTS, ALWAYS SPECIFY MODEL, REV,
PART NUMBER, AND SERIAL NUMBER OF UNIT.

GLOBE FOOD EQUIPMENT COMPANY

2215 East River Road
Dayton, Ohio 45439

Parts Department

Toll Free 1-800-745-6238 · Fax (937) 290-0585

E-Mail: info@globefoodequip.com

Website: www.globefoodequip.com

Not for resale

Table of Contents

Description	Page
E220 Slicer Base Components	4
E220 Chute Components	6
E220 Knife & Sharpener Components	8
E220 Electrical Components	10
E220 Wiring Diagram	12

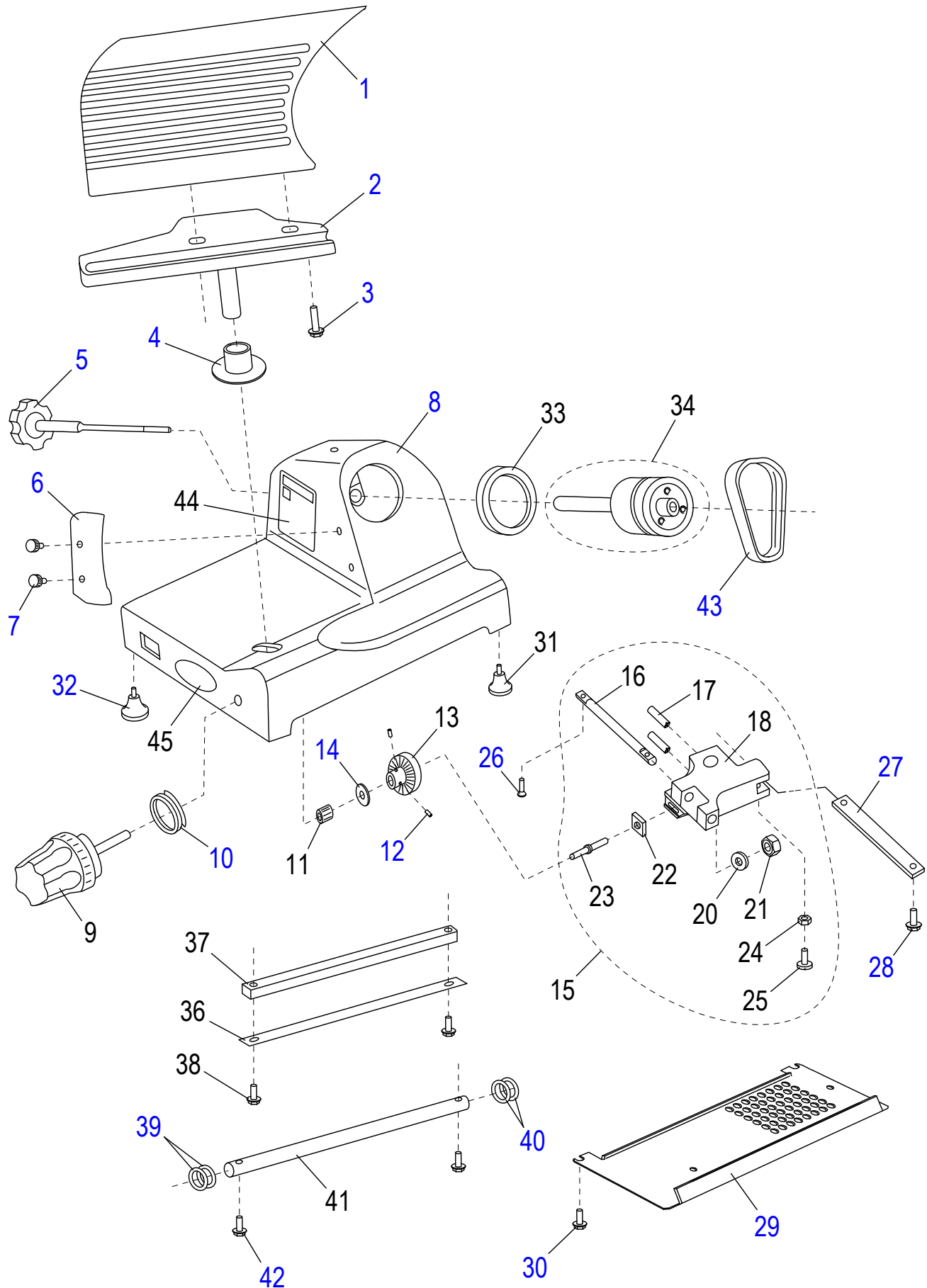



E220 Slicer Base Components

Item	Part Number	Description	Qty	Serial Number
1	G00069	Table	1	
2	G00074	Table Support	1	
3	H00043	Hex Head Screw M6 x 25 mm- Zn	0	
4	G00076	Hole Cover	1	
5	G00077	Knife Cover Release Knob	1	
6	G00078	Slice Deflector	1	
7	22-A	Screw	2	
8		Aluminium Base	1	
9	G00079	Index Knob	1	
10	G00081	V Seal	1	
11	G00082	Sleeve	1	
12	H00047	Set Screw, M5x5 Flat Pt, Hex Socket - BO	2	
13	27	Cam	1	
14		Wavy Washer	1	
15	ET33	Table Slide Assembly	1	
16		Table Adjustment Shaft	1	
17	H00048	Set Screw, M8x8 Cup Pt, Hex Socket - BO	2	
18		Table Slide	1	
19		Bearing, Table Slide (Not Shown)	2	
20	H00014	Flat M6 Washer - Zn	1	
21	H00020	Hex Nut, M6	1	
22	H00044	Square Nut M6 - Zn	1	
23		Indexing Cam Conic Shaft	1	
24	H00028	Hex Nut M5 - Zn	1	
25	H00049	Screw, Slotted Cyl Hd M5x16 - Brass	1	
26	M048	Flat Hd Screw M5x0.8x16 mm, Zinc 8.8 Slotted	2	
27		Plate, Table Adjustment	1	
28	H00061	Hex Head Screw M5x10, Zinc	2	
29	G00084	Bottom Cover	1	
30	H00061	Hex Head Screw M5x10, Zinc	4	
31	D40	Foot (4/Set)	4	
32	G00085	Large Foot	2	
33	ET52C	V Seal (Optional)	1	
34	G00088	Drive Hub Assembly	1	
35	H00053	Retaining Ring, Internal (Not Shown)	1	
36	G00090	Wear Strip	1	
37	G00091	Square Slide Bar	1	
38	H00054	Cap Screw, Hex Washer Head M5 x 18 - Zn	2	
39	H00057	Spring	4	
40	H00059	O-Ring	1	
41	G00093	Round Slide Rod	1	
42	H00054	Cap Screw, Hex Washer Head M5 x 18 - Zn	2	
43	55	Belt	1	
44	81	Warning Label	1	
45	83-A	Chefmate Logo	1	

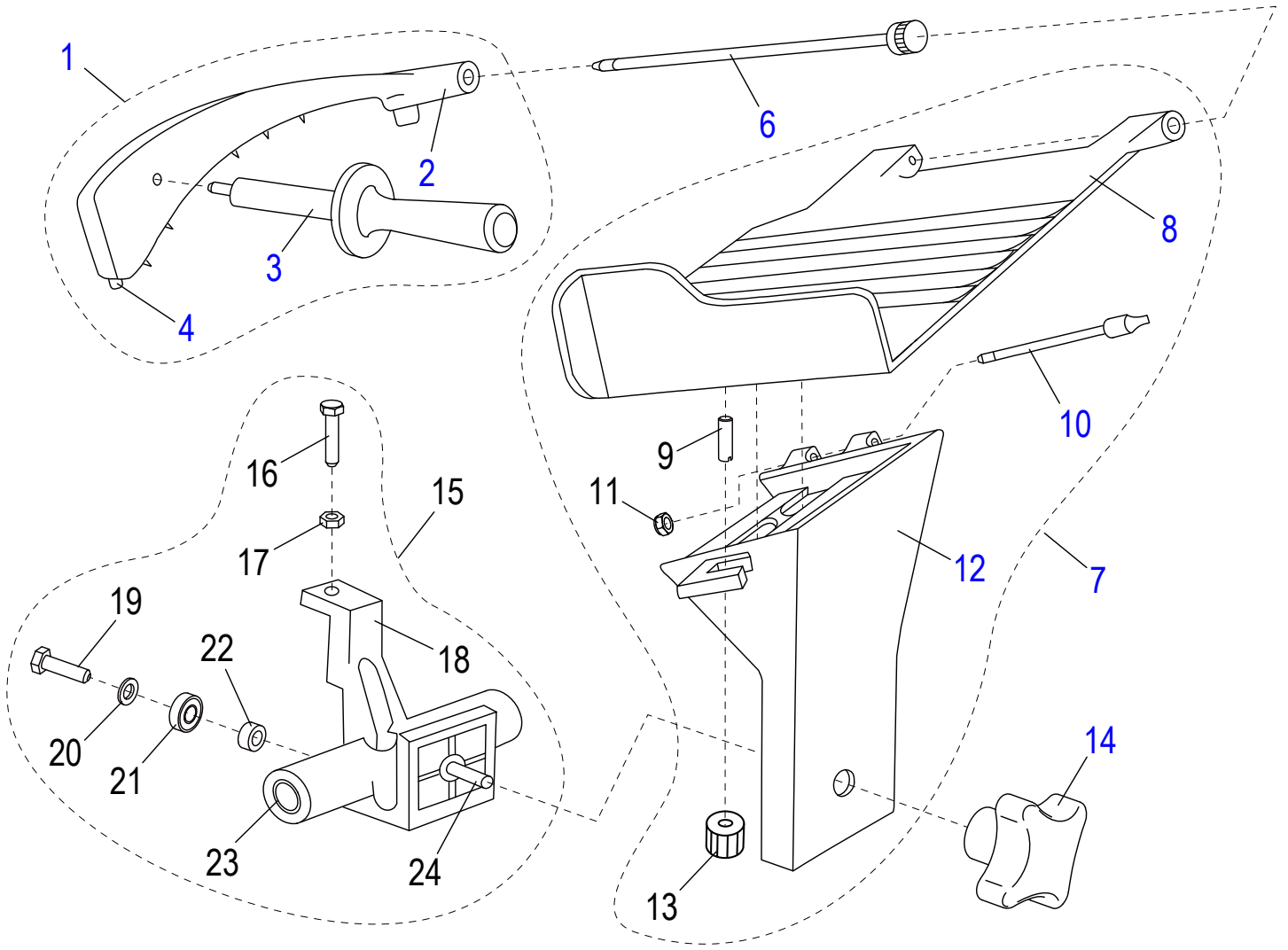



E220 Chute Components

Item	Part Number	Description	Qty	Serial Number
1	G00122	End Weight Assembly	1	
2		End Weight	1	
3	G00124	End Weight Handle	1	
4	G00125	Bumper	1	
5		Bushing (Not shown)	2	
6	G00128	End Weight Rod	1	
7	G00135	Complete Chute Assembly	1	
8	G00131	Food Chute	1	
9	H00060	Set Screw, M6x16 Flat Pt Slotted - Zn	1	
10	G00138	Chute Unlock Pin	1	
11	H00064	Hex Nut, Nylon Insert M5	1	
12	G00140	Chute Support	1	
13	G00141	Carriage Unlock Knob	1	
14	72	Chute Support Knob	1	
15	G00144	Chute Slide Assembly	1	
16	H00145	Screw, Hex Head M6 x 20 mm - Nylon	1	
17	M034	Hex Nut M6x1.0 OD 10 mm TH 5 mm Zinc	1	
18		Chute Slide	1	
19	H00043	Hex Head Screw M6 x 25 mm- Zn	1	
20	M035	Flat Washer ID 6.5 OD 12 TH 1.5 mm Zinc	1	
21	MCA29	Bearing (626 2RS)	1	
22		Spacer	1	
23		Bushing (Not Shown)	2	
24	46-A	Threaded Rod	1	

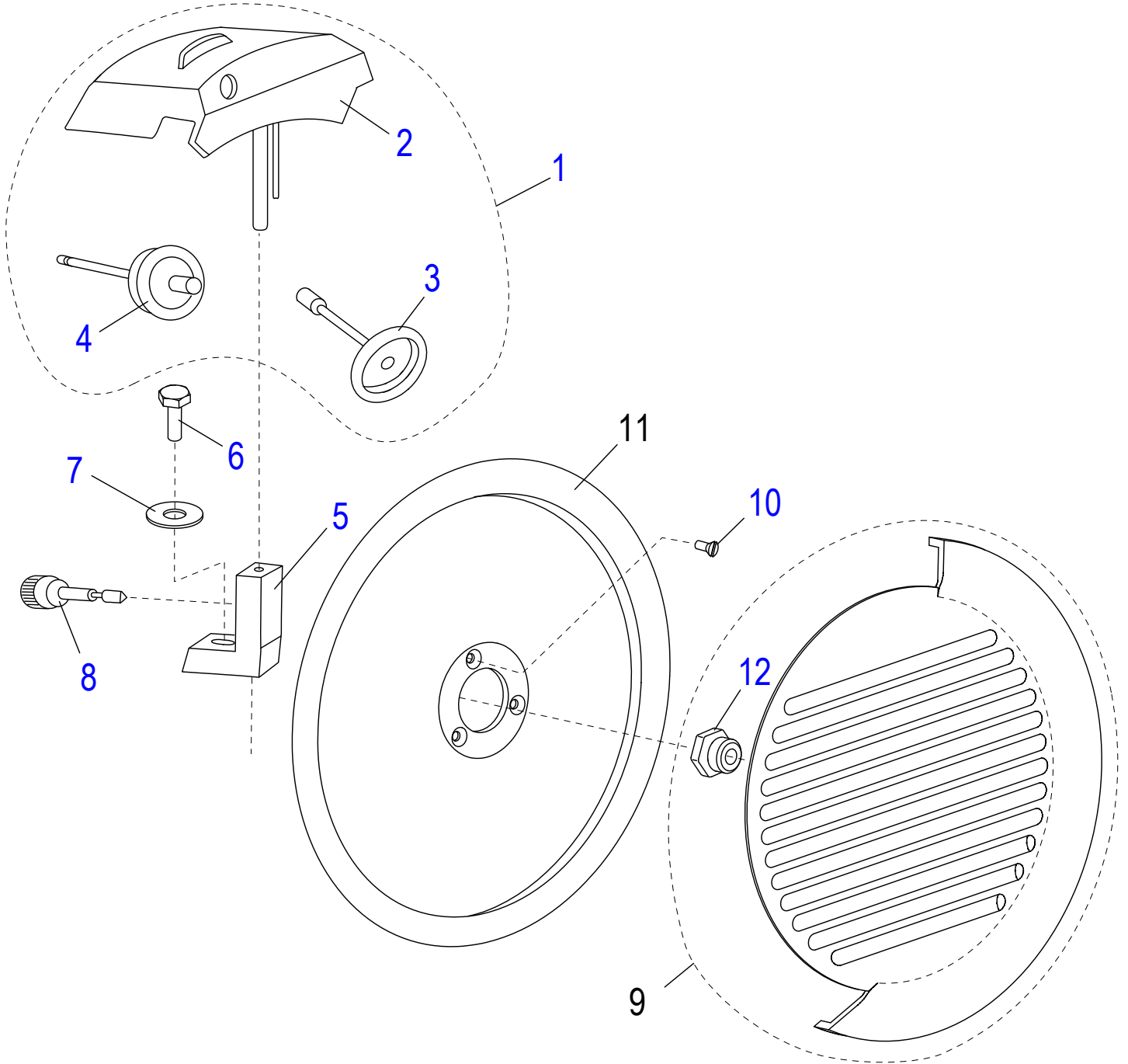



E220 Knife & Sharpener Components

Item	Part Number	Description	Qty	Serial Number
1	G00098	Sharpener Assembly	1	
2	G00094	Sharpener Cover	1	
3	G00105	Sharpening Stone (Coarse)	1	
4	G00108	Deburring Stone (Fine)	1	
5	G00112	Sharpener support	1	
6	H00116	Hex Head Screw M6-1.0x20 - Zn	1	
7	H00120	Flat Washer M6x18mm	1	
8	10-B	Sharpener Adjustment Knob	1	
9	G00113	Knife Cover	1	
10	56-A	Flat HD Screw- Slotted, ZINC-8.8	3	
11	56	Knife	1	
12	59-A	Insert	1	

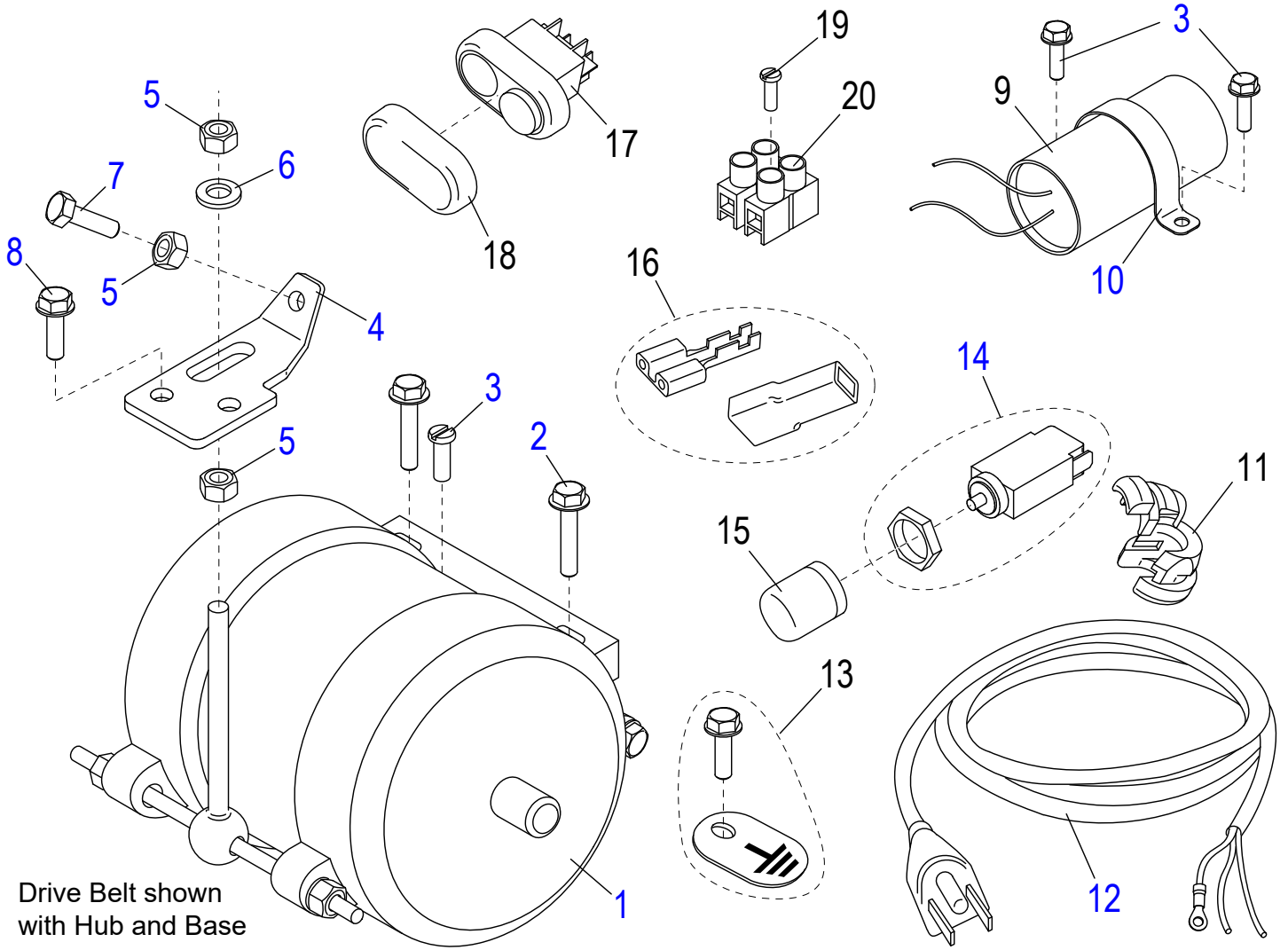

Drive Belt shown with Hub and Base



E220 Electrical Components

Item	Part Number	Description	Qty	Serial Number
1	G00151	Motor (115V/60Hz/2.3A)	1	
2	H00055	Cap Screw, Hex Washer Head M5 x 23 - Zn	2	
3	H00061	Hex Head Screw M5x10, Zinc	1	
4		Belt Tightener Plate	1	
5	M034	Hex Nut M6x1.0 OD 10 mm TH 5 mm Zinc	3	
6	M035	Flat Washer ID 6.5 OD 12 TH 1.5 mm Zinc	1	
7	H00043	Hex Head Screw M6 x 25 mm- Zn	1	
8	H00061	Hex Head Screw M5x10, Zinc	3	
9	ET31	Capacitor	1	
10		Capacitor Holder	1	
11	877	Strain Relief	1	
12	132-3	Power Cord	1	
13	G00152	Ground Screw	1	
14	89	Reset Switch	1	
15	G00154	Reset Switch Cover	1	
16	G00167	Terminal & Insulator	6	
17	ET28-1	Power Switch	1	
18	G00153	Power Switch Cover	1	
19	M029	Screw	1	
20	G00155	Terminal Block w/Screw	1	



E220 Wiring Diagram

