



Induction Counter-Top Series

R·T·C·S[®] Dual Base-Line Models

Installation, Operation and Maintenance Manual



models

GI-SH/DU/BA 7000
GI-SH/DU/BA 10000

Original Instructions

Part Number 4532290 Rev.3 12/15



READ THIS MANUAL

▲Warning

Read this manual thoroughly before installing, operating, or performing maintenance on the equipment. Failure to follow instructions in this manual can cause property damage, injury or death.

This manual must always be available for reference at the place of operation.

This manual is intended for kitchen consultants, cabinet designers, fabricators, installers, owners and operators of our appliances.

Owners, consultants, fabricators and designers:

In order for the induction appliance to function safely and normally, you must read and understand all specific and critical requirements when designing the location and the counter for the appliance.

Installers, operators and staff:

For your safety and safety of the others, you must observe all safety instructions during installation, operation and maintenance of the equipment.

Should you require technical assistance, call your factory authorized service agent or distributor. **Always have your model and serial number available when you call.**

Your Factory Authorized Service Agent

Service Agent Telephone Number

Your Local Equipment Supplier

Supplier Telephone Number

Model Number

Serial Number

Date of Installation

ABOUT THIS MANUAL

Throughout this manual, the induction appliance model indicated on the cover page is referred to as **appliance, induction appliance or equipment.**

A period (.) is used in this manual as the decimal separator.

Original measurements are in metrics. Measurements in imperial are provided for reference.

Not ALL models, options and accessories are available in all geographical regions. Please consult your local equipment supplier for the availability of the specific products in your region.

INSPECT THE SHIPMENT

Thoroughly inspect the equipment upon delivery. Immediately report to the delivery carrier, any damage that occurred during transportation and request for a written inspection report from a claim inspector.

Your shipment might include small packages of fasteners or silicone strips for installation. Keep all packages.

KEEP THE PACKING SLIP

The packing slip attached to the shipment contains detailed information on all components. Keep the packing slip for reference.

Safety Notices

DEFINITIONS

⚠ DANGER
 Indicates a hazardous situation that, if not avoided, will result in death or serious injury. This applies to the most extreme situations.

⚠ Warning
 Indicates a hazardous situation that, if not avoided, could result in death or serious injury.







⚠ Caution
 Indicates a hazardous situation that, if not avoided, could result in minor or moderate injury.

Notice
 Indicates information considered important, and is used to address practices not related to physical injury. For example, messages relating to property damage.

NOTE: Indicates useful, extra information about the procedure you are performing.

Reference: ANZI Z535.6-2011

SAFETY SYMBOLS AND WARNINGS ON THE APPLIANCE

	This symbol alerts you to a hazardous situation that WILL or COULD cause serious bodily harm or death. Be alert and implement relevant safety precautions.
	DANGER - HIGH VOLTAGE This dangerous voltage warning symbol indicates a risk of electric shock and hazards from dangerous voltage.
	Electromagnetic Field
 Warning  RISK OF FIRE OR ELECTRIC SHOCK! DO NOT OPEN! To reduce the risk of fire or electric shock, do not remove or open cover. No user serviceable parts inside. Refer servicing to qualified personnel.	
CAUTION  ATTENTION DISCONNECT FROM SUPPLY CIRCUIT BEFORE OPENING	

DISCLAIMERS

⚠ DANGER
 Disregarding any safety instructions may cause harm to people, the surroundings, and the equipment. Garland is not responsible for any damages or personal injury caused by failure to observe any safety requirements. Risks involved when disregarding safety precautions include, but not limiting to:

- Death or injury caused by electric shock.
- Burn injury caused by contacting overheated cooking surface, cookware, or oil and grease.
- Damage to the equipment caused by using unsuitable cookware.

⚠ DANGER
 Do not install or operate equipment and/or accessories that have been misused, abused, neglected, damaged, or altered from that of original manufactured specifications.

⚠ DANGER
 Contact the manufacturer if you intend to make any changes on the equipment. For safety reasons, always use genuine parts and accessories approved by the manufacturer or authorized representative. Refer to the warranty documents for your equipment.

⚠ DANGER
 Owners and operators are cautioned that maintenance and repairs must be performed by an authorized service agent using only genuine replacement parts. The manufacturer will have no obligation with respect to any product that has been improperly installed, adjusted, operated or not maintained in accordance with national and local codes and/or installation instructions provided with the product or any product that has its serial number defaced, obliterated or removed, and/or which has been modified or repaired using unauthorized parts or by unauthorized service agents.

⚠ DANGER
 Improper installation, adjustment, alteration, service, or maintenance of this appliance or installation of a damaged appliance can result in DEATH, INJURY, EQUIPMENT DAMAGE, and void the warranty.

⚠ DANGER
 All utility connections and fixtures must be maintained in accordance with local and national codes.

⚠ Warning

Do not store or use gasoline or other flammable vapors or liquids in the vicinity of this or any other appliance. Never use flammable oil soaked cloths or combustible cleaning solutions for cleaning.

⚠ Warning

This appliance is not intended for use by persons (including children) with reduced physical, sensory or mental capabilities, or lack of experience and knowledge, unless they have been given supervision concerning use of the appliance by a person responsible for their safety. Do not allow children to play with this appliance.

⚠ Warning

This product contains chemicals known to the State of California to cause cancer and/or birth defects or other reproductive harm. Operation, installation, and servicing of this product could expose you to airborne particles of glass-wool or ceramic fibers, crystalline silica, and/or carbon monoxide. Inhalation of airborne particles of glass-wool or ceramic fibers is known to the State of California to cause cancer. Inhalation of carbon monoxide is known to the State of California to cause birth defects or other reproductive harm.

⚠ Warning

Authorized Service Representatives are obligated to follow industry standard safety procedures, including, but not limited to, local/national regulations for disconnection / lock out / tag out procedures for all utilities including electric, gas, water and steam.

Notice

This appliance is not approved or authorized for home or residential use, but is intended for commercial applications only. The manufacturer and/or authorized representative will not provide service, warranty, maintenance or support of any kind other than in commercial applications.

Notice

Routine adjustments and maintenance procedures outlined in this manual are not covered by the warranty.

NOTE: Proper installation, care and maintenance are essential for maximum performance and trouble-free operation of your equipment. Visit our website www.mtwkitchencare.com for manual updates, translations, or contact information for service agents in

your area.

CORRECT DISPOSAL OF THIS PRODUCT

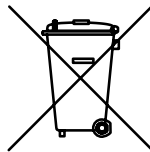

This marking shown on the product indicates that the product should not be disposed as household waste or regular commercial waste. Instead it shall be handed over to the applicable collection point for the recycling of electrical and electronic equipment. By ensuring this product is disposed correctly, you will help prevent potential harm to the environment or human health, which could otherwise be caused by inappropriate waste handling of this product.

For more detailed information regarding recycling of the product, please contact your local city office or your waste disposal service.

⚠ DANGER

Induction appliances, sent for disposal, can be brought back into operation and their use must be avoided.

NOTE: The appliance is built with common electrical, electromechanical and electronic parts. No batteries are used.

NOTE: The owner and operator are responsible for the proper and safe disposal of the appliance.

Table of Contents

Safety Notices

Definitions.....	3
Safety symbols and Warnings on the Appliance	3
Disclaimers.....	3
Correct Disposal of This Product.....	4

Section 1 General Information

Description of Product.....	7
Application	7
Compliances	7
Components and Features	7
Serial Plate Location	8
Model Number.....	8
Serial Number.....	8
Accessories.....	8

Section 2 Installation

Installation safety—Disclaimer	9
Installation Safety—Clearance and Ventilation.....	9
Personal Protection	10
Installation Safety—Electrical.....	10
Specifications	11
Dimensions: SH/DU/BA 3500 (7kW), SH/DU/BA 5000 (10kW)	11
Installation Clearance	12
Parallel installation and Clearance	12
Electrical Specifications.....	13
Electrical Cables	13
Operating Conditions	13
Weights	13
Installation Instructions	14
Location of the Induction Appliance	14
Ventilation Requirements.....	14
Adjusting and Locking the Feet.....	14
Commissioning	15
Function Test.....	15

**Section 3
Operation**

Operation Safety—Disclaimer 16
 Operation Safety—Personal Protection..... 16
Important Rules—Operation and Maintenance..... 18
Proper Induction Cookware 19
 Condition 19
 Round bottom Wok pans..... 19
 Material 19
 BOIL TEST 19
 Size of Pan 20
Placing Pan On A Cook Zone 20
Power Control 21
 Power Level Settings..... 21
Automatic Pan Detection, No Pan No Heat 22
Reading the Signals from An Indicator Lamp 22
When Appliance Is Idle..... 22

**Section 4
Maintenance**

Maintenance Safety—Disclaimer 23
 Dangerous Electrical Voltage 23
 Maintenance Safety—Cleaning 23
 Personal Protection 24
Daily Cleaning and Maintenance 25
 Glass Cleaning 25
 Stainless Steel case 25
 Visual Inspection of Silicone Seal 25
Weekly Cleaning and Maintenance 25
 Air Intake Filter, Countertop Models 25
 Air Intake Filter, Built-In Models 26
Yearly Maintenance..... 26

**Section 5
Troubleshooting**

Dangerous Electrical Voltage 27
Common Problems..... 27
Symptoms 27
Boil Test 27
Troubleshooting Without Error Code / Flash Code 28
Troubleshooting — Error Code / Flash Code..... 28
Wearable Parts List..... 30

Section 1

General Information

Description of Product

Built with a robust construction, our induction appliances are compact and powerful with the revolutionary RTCS® or RTCSmp® Technology (Realtime Temperature Control System).

The RTCS®/RTCSmp® Technology monitors continuously in realtime, the energy supply, temperature of the cook zone, and the state of the components such as the induction coil. This monitoring system ensures the most efficient energy transfer, as well as maximizes safety:

- Safety functions such as Pan Detection and Boil Dry Protection are therefore guaranteed.
- The appliance generates power only when a pan is in contact with the cook zone surface.
- When a malfunction occurs, the integrated fault diagnostic system reports the malfunction instantly.

Application

The RTCS®/RTCSmp® induction appliances are designed as compact equipment for use on the surface of a counter or table.

Many applications throughout the day with your appliance are possible, such as cooking, warming up, keeping warm, flambéing, and roasting of food. All these applications are possible because:

- Temperature control is instantaneous and precise. Instant energy transmission from inverter coil to the bottom of cookware, allows for fast startup time.
- High power is possible for braising application and quick saute.
- High power also means you can heat up a large stockpot quickly (3.5kW coil or above).

NOTE: To guarantee the reliability and performance of the appliance, you must use the recommended types and sizes of pans with the appliance. See section 3 Operation.

Compliances



- **North American models:**
ETL listed in compliance with UL 197, CSA C22.2 No.109, NSF-4. Complies with FCC part 18, ICES-001
- **CE models** comply with the latest European Norms:
EN 60335-1, EN 60335-2-36, EN 62233 (EMC/EMV)
Complies with EU-norms for EMC immunity.

Components and Features

Your induction appliance comes fully assembled.

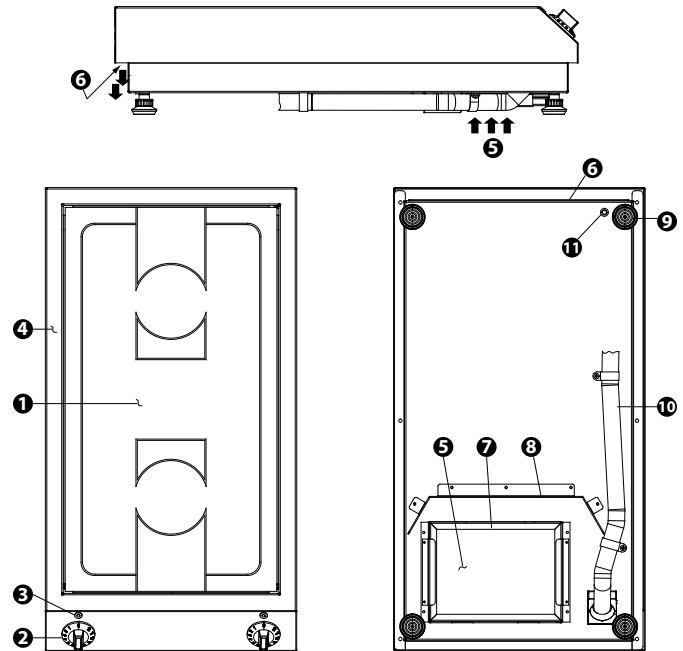

	Indicates the direction of airflow.
1	Ceran® Glass Cook-Top, dual cook-zones
2	Rotary power switch, allows for continuously variable power adjustment. Dial is marked 0 to 12 power levels. The front control panel is sloped for ease of operation.
3	Indicator lamp <ul style="list-style-type: none"> • Illuminates when the appliance is ON. • Blinks when the appliance is in Pan Detection Mode. • Blinks at intervals when a malfunction occurs More details in sections 3 Operation and 5 Troubleshooting.
4	CrNi-steel exterior structure.
5	Fresh air intake. An integrated fan pulls air in through the filter to cool the electronics.
6	Air exhaust vent, allows hot exhaust to escape.
7	Air filter, cleans the intake air. The filter is removable, reusable and dishwasher-safe.
8	Air deflector, prevents hot exhaust from the rear to be pulled back into the appliance through the fresh air intake opening.
9	Feet that are height adjustable and lockable.
10	Power supply cable and plug included, 1.8-meter [6-foot] long (exception 440V appliance).
11	Grounding bolt

Serial Plate Location

The serial plate specifies the model number, serial number, and electrical specifications of the appliance.

See illustration below for location.

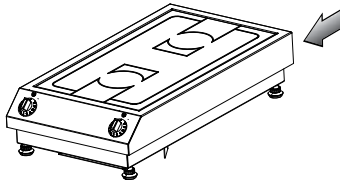

Model Number

The model number is located on the serial plate. This manual covers the following models:

SH/DU/BA 3500¹ SH/DU/BA 5000²

¹3500 Watts per cook zone, total of 7000 Watts

²5000 Watts per cook zone, total of 10000 Watts

READING THE MODEL NUMBER

Example: **SH/DU/BA 3500**



1	Product Series	SH = Slim Hob
2	Multi-Zone	DU = Dual Cook Zones
3	Function	BA = Base Line Cooktop
4	Power (Watt)	3500, 5000 (per Cook Zone)

MARKETING IDENTIFIER

Marketing identifier is used when specifying the product on specification sheet and other marketing literature. This product is identified as:

GI-SH/DU/BA 7000

GI-SH/DU/BA 1000

Serial Number

The serial number is located on the serial plate.

READING THE SERIAL NUMBER

Example: **BA01 . 00014 . 1214**



1	Type of induction appliance: BA = Base Line Series (Counter-Top Cook-Top) IN = Built-In Series WO = Counter Wok Series MO = Module Line Series HO = Hold Line Series GR = Griddle Line Series
2	Last two(2) or three(3) digits of the appliance article number or part number that can be found on the invoice or the packing slip.
3	A sequential number: <ul style="list-style-type: none"> • A 4-digit sequence number indicates that the appliance is not RTCS® nor RTCSmp®. • A 5-digit sequence number indicates that the appliance is either a RTCS® or RTCSmp® appliance. • A RTCSmp® appliance is marked as such on the serial plate.
4	Month of manufacture: 01, 02, 03, 04, ...
5	Year of manufacture: 2014 (14), 2015 (15), ...

Accessories

Induction cooking equipment requires **Induction Ready** pans to operate. Please consult your equipment supplier for a list of our pan selection and prices.



Section 2 Installation

INSTALLATION SAFETY—DISCLAIMER

DANGER

Installation must be carried out by registered installation contractors only.

The contractors are responsible for interpreting all instructions correctly and performing the installation in compliance with all applicable national and local regulations.

The warning signs and serial plates on the equipment must strictly be followed.

Warning

This equipment is intended for indoor use only. Do not install or operate this equipment in outdoor areas.

Warning

To avoid instability, the installation area must be capable of supporting the combined weight of the equipment and food product. The equipment must be level side to side and front to back.

Caution

Consultants, fabricators and designers must consult their counter-top suppliers when designing an appropriate support structure and clearance for the counter-top and the installation.

Notice

Induction equipment that is not installed correctly will have warranty voided.

INSTALLATION SAFETY—CLEARANCE AND VENTILATION

DANGER

Risk of Fire or Shock or Equipment Failure

All minimum clearances must be maintained. Air intake vents and exhaust vents must not be blocked or be restricted by the installation.

Caution

This equipment must only be operated under an approved ventilation system in accordance with all applicable national and local regulations. Exceptions may apply.

Notice

The maximum ambient temperature for the induction appliance to operate must not exceed 40°C [104°F].

Failure to provide adequate ventilation will cause the appliance to overheat, to reduce power, or to shutdown.

NOTE: Always maintain enough space between and around the equipment for maintenance and service.

INSTALLATION SAFETY—ELECTRICAL**⚠ DANGER**

All electrical connections must be carried out by a certified electrical contractor, who is responsible for the correct rating and installation of the appliance. The contractor has to comply with all legal safety regulations and all applicable national and local electrical codes.

⚠ Warning

Markings and warning labels mounted directly on the equipment must be observed at all times and kept in a fully legible condition.

⚠ Warning

This equipment must be positioned so that the plug is accessible unless other means for disconnection from the power supply, such as circuit breaker or disconnect switch, is provided.

⚠ Warning

CE Induction Appliance only: If ground fault current protective switches are used, they must be provided with selective activation and designed for a minimum fault current of 30mA.

Notice

Ensure the supply voltage and the line current match the specifications given on the serial plate affixed to the appliance. Wrong voltage will damage the appliance. A stable power supply must be provided.

Notice

Always refer to the serial plate on the appliance to verify the electrical data. When the data listed on the serial plate is different than that listed in this manual, contact the manufacturer or the authorized representative.

Notice

All cables must be routed, protected and tension free.

PERSONAL PROTECTION**⚠ DANGER**

All utilities (gas, electric, water and steam) must be OFF to all equipment and locked out of operation according to national/regional, as well as company approved practices during installation, maintenance and servicing. Always allow appliance to cool.

⚠ DANGER

Use appropriate safety equipment during installation, maintenance and servicing.

⚠ DANGER

Never stand, sit, or lean on the equipment! They are not designed to hold the weight of an adult, and may collapse or tip if misused in this manner.

⚠ DANGER

To avoid cardiac pacemaker malfunction, consult your physician or pacemaker manufacture about effects of electromagnetic field on your pacemaker.

⚠ Warning

Markings and warning labels mounted directly on the equipment must be observed at all times and kept in a fully legible condition.

⚠ Warning

Risk of burns from high temperatures. You may get burnt if you touch any of the parts during operation. Surfaces close to the cooking area including side panels may get hot enough to burn skin. Use extreme caution to avoid coming in contact with hot surfaces or hot grease. Wear personal protective equipment.

⚠ Caution

Use caution when handling metal surface edges of all equipment.

Specifications

DIMENSIONS: SH/DU/BA 3500 (7KW), SH/DU/BA 5000 (10KW)

Measurements in millimeter and [inch].

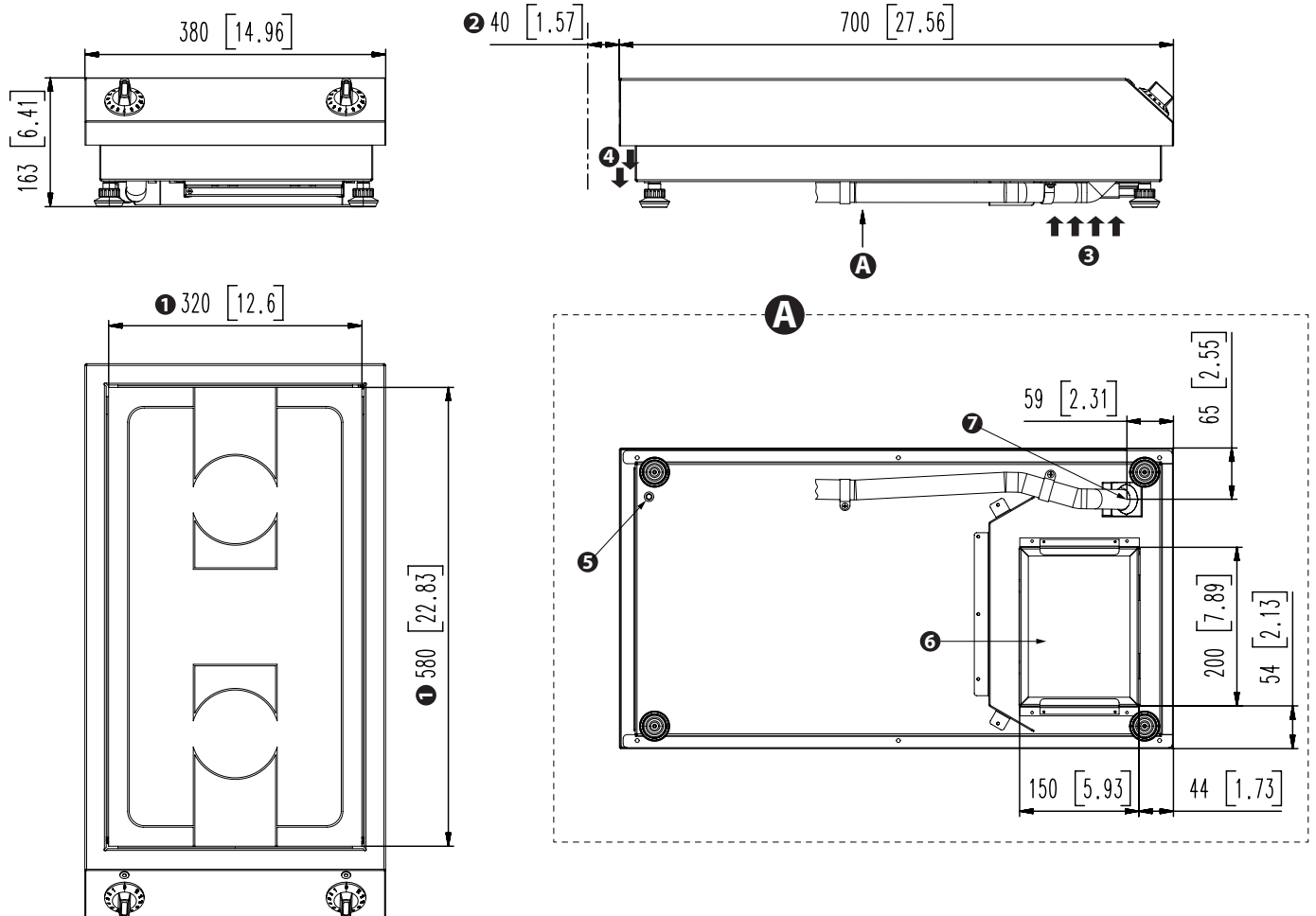

➔	Indicates the direction of airflow
1	Dimension of the Ceran® glass cook-top
2	Distance to wall or other obstruction, minimum = 40mm [1.57"]
3	Fresh air supply
4	Air exhaust
5	Grounding bolt
6	Fresh air intake and air filter
7	Mains power cable

INSTALLATION CLEARANCE

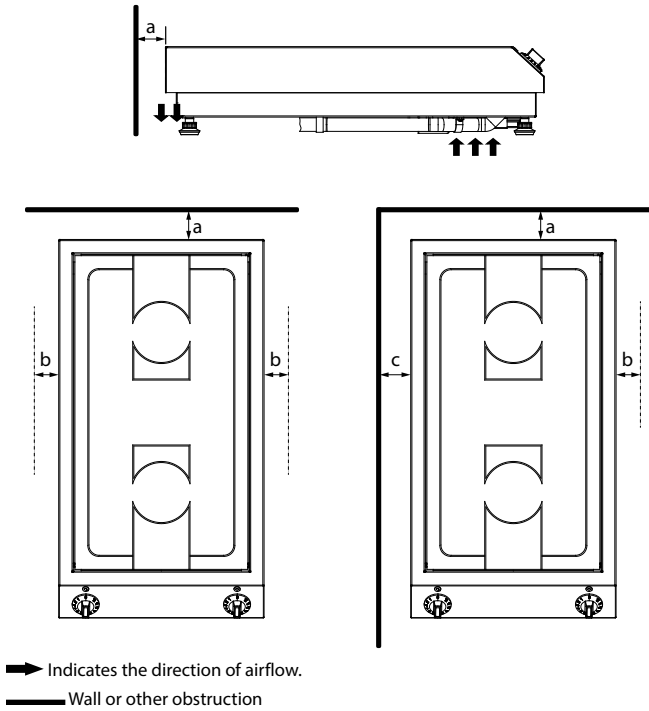

Dimension **a** — minimum clearance, air exhaust
 Dimension **b** — minimum body clearance, sides
 Dimension **c** — minimum clearance, if appliance is installed in a tight space or corner (left side, right side, or both)

Model	a		b		c	
	mm	inch	mm	inch	mm	inch
BH/DU/BA	40	1.57	20	0.79	40	1.57

PARALLEL INSTALLATION AND CLEARANCE

A gap between two SH/DU/BA units is not required.

Notice
 The orientation of each appliance in a parallel configuration will affect the ventilation requirements. Ensure the final installation meets all operating and ventilation requirements.



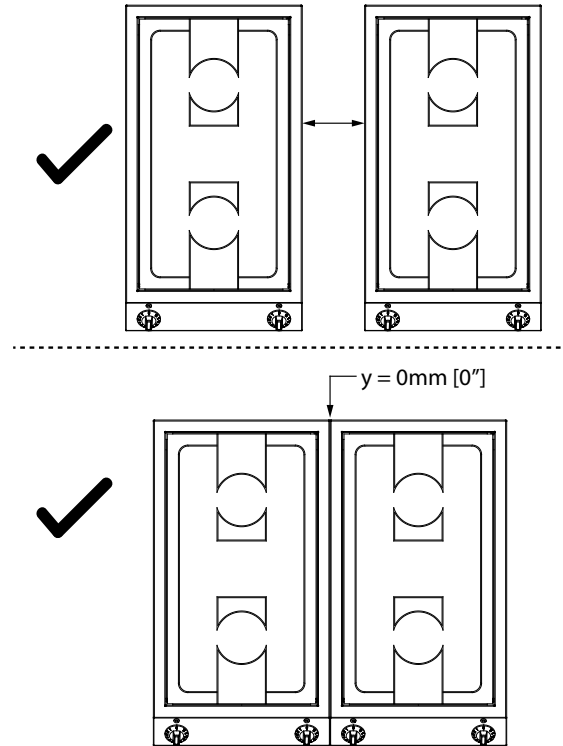

NOTE: Consideration for Operation. Consider the sizes of typical frying or wok pans and include adequate space in between the equipment for ease of operation.



Dimension **y** — minimum gap required

Model	y	
	mm	inch
BH/DU/BA	0	0

ELECTRICAL SPECIFICATIONS

Model	Power	Voltage (50/60 Hz)	Plug
SH/DU/BA 3500	7000W (2x3500W) 22A	208V 3Φ	 NEMA 15-30P
	7000W (2x3500W) 11A	400V 3Φ	 EU 5-Pole
	7000W (2x3500W) 10A	440V 3Φ	plug not included
SH/DU/BA 5000	10000W (2x5000W) 30A	208V 3Φ	 NEMA 15-50P
	10000W (2x5000W) 16A	400V 3Φ	 EU 5-Pole
	10000W (2x5000W) 15A	440V 3Φ	plug not included

Notice

440V Appliance: The electrician must equip the appliance with a mains power plug in compliance with all applicable national and local regulations.

ELECTRICAL CABLES

Power supply cable and plug included, 1.8-meter [6-foot] long (exception 440V appliance).

OPERATING CONDITIONS

For the appliance to function properly, the following conditions must be maintained.

Maximum Tolerance of the Nominal Supply Voltage	+6 /-10 %
Network Impedance (Zmax.)	0.25Ω
Supply frequency	50/60 Hz
Ingress Protection class	IP X3
Minimal Diameter of Induction Pan	12cm [5"]
Maximum Ambient Temperature	In Storage, -20°C to +70°C [-4°F to +158°F]
	In Operation, +5°C to +40°C [+41°F to +104°F]
Maximum Relative Air Humidity	In Storage, 10% to 90%
	In Operation, 30% to 90%

WEIGHTS

Model	Net Weight	
	kg	lb
SH/DU/BA 3500 (7kW, 2x3500W)	22	48.5
SH/DU/BA 5000 (10kW, 2x5000W)	24	52.9

Installation Instructions

LOCATION OF THE INDUCTION APPLIANCE

Caution

Do not position the air intake vent near steam or heat exhaust of another appliance.

- The induction appliance must be installed on an even, flat, non-combustible surface.
- The surface must be able to withstand a load of 80kg [176.4lb] per appliance that is listed in this manual.
- Ensure the induction appliance is stable and will not slide or fall down.
- The induction appliance must not be installed or placed near or on a hot surface.
- The induction appliance must be level.
- Similar to other electronic equipment, induction equipment is sensitive to moisture and high heat. Protect the induction appliance from heat, steam and grease generated by other equipment, such as oven, deep fryer, pasta cooker, steamers, and water bath.
- The controls on the front panel must not be blocked or obstructed.
- Keep the induction appliance away from combustible materials, vapors or liquids.

VENTILATION REQUIREMENTS



Read and understand all installation safety instructions regarding Clearance and Ventilation at the beginning of this chapter.

- See also [Operating Conditions](#) on page 13.
- See also [Installation Clearance](#) on page 12.
- Ensure the induction appliance does not take in hot ambient air or steam from another appliance, especially when the appliance is installed next to heat generating equipment such as fryers or ovens.

ADJUSTING AND LOCKING THE FEET

The feet on the appliance are height-adjustable and lockable.

Optional. To prevent the appliance from slipping, Tabletop Self-Adhesive Foot Pads can be purchased for the feet. Insert the feet into the Foot Pads and the feet can then be affixed to the surface of the counter or table.

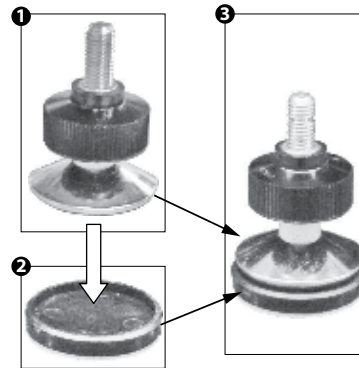

1. Foot Complete Assembly, part number 95000120
2. Tabletop Self-Adhesive Foot Pad, part number 72264020 (set of four).
3. Foot and non-slip pad assembled.

To adjust the height of the appliance:

1. Rotate the feet counter-clockwise to lower the appliance. Or rotate the feet clockwise to raise the appliance.

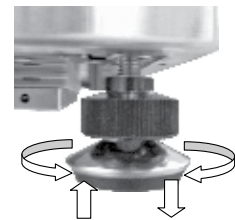

2. To lock the feet into position, rotate the locks counter-clockwise until the locks are tightened against the bottom of the appliance.

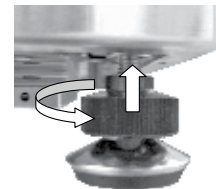

3. The feet are locked.

NOTE Ensure the appliance is level.



COMMISSIONING

Read and understand all installation safety instructions regarding Electrical and Personal Protection.

1.

Warning

Ensure the control knobs are in the 0 (OFF) position BEFORE connecting the appliance to the electrical supply.

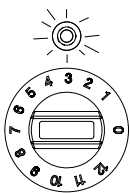
**ON-Position**

Any position other than "0" is pointing to the Indicator lamp. The lamp is on.

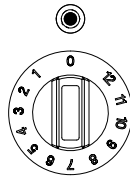
**OFF-Position**

"0" is pointing to the indicator lamp. The lamp is off.

2. Remove all objects from the glass-top and examine the glass.

Caution

Do not continue if the glass-top is cracked, chipped or damaged in any other way. Contact an authorized service agency for assistance.

3. Connect the appliance to power supply.
4. Perform an operation test. See instructions in [Function Test](#) on page 15.

Function Test

- Read and understand all installation safety instructions regarding Personal Protection.
- Observe also ALL operation safety requirements in section 3 Operation.

Testing procedure:

1. Examine the cookware for induction cooking:
 - Pans must be induction ready. See details in section 3 Operation.
 - Minimum pan size: Pan must have bottom diameter larger than 12cm [5"]. Otherwise, the pan will not be heated. This is a safety feature. The sensors do not detect pan smaller than this minimum size.
2. Put some water in an induction pan and place it in the center of the cook-zone.
3. Turn the control knob to a ON-position. The indicator lamp illuminates and the water is heated.

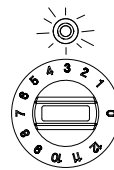
**ON-Position**

Any position other than "0" is pointing to the Indicator lamp. The lamp is on.

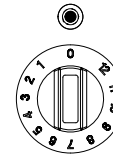
**OFF-Position**

"0" is pointing to the Indicator lamp. The lamp is off.

4. Remove the pan away from the cook-zone.
NOTE: When power transmission to the pan bottom stops, the indicator lamp blinks.
5. Place the pan back on the cook-zone. The heating process resumes.
NOTE: The indicator lamp illuminates continuously again when energy is being transferred to the pan.
6. Turn the control knob to the OFF/"0"-position. The heating process stops; the indicator lamp goes off.

If the appliance does not function as expected despite using quality induction pans, refer to section 5 Troubleshooting.

To test the efficiency of a pan for induction cooking, refer to section 5 Troubleshooting.

Section 3 Operation

OPERATION SAFETY—DISCLAIMER

⚠ DANGER

The on-site supervisor is responsible for ensuring that operators are made aware of the inherent dangers of operating this equipment.

⚠ DANGER

Risk of fire/shock/equipment failure. **All minimum clearances must be maintained. Do not obstruct vents or openings.**

⚠ Warning

This equipment is intended for indoor use only. Do not install or operate this equipment in outdoor areas.

Notice

The reliability of the appliance can only be guaranteed when it is used properly. The appliance must always be operated within the limits and/or the operating conditions provided in this manual.

Notice

Avoid dropping any hard objects onto the equipment. Damages to the heating surface will shorten the life cycle of the equipment or incur high service costs.

Notice—Models with Glass-Top Use Only Induction Suitable Cookware

Use only induction suitable cookware with proper sizes and made of proper material. The induction suitable cookware must be in good condition without any uneven, arched or partially detached bottoms.

Using unsuitable cookware can cause the appliance to fail prematurely, void your warranty, or incur high service costs.

Notice—Induction Griddles / Braising Pans

NEVER heat any cooking pan on the griddle plate or in the braising pan. Heating cooking pan with these equipment will damage these equipment. Heat only food products on the griddle plate or in the braising pan.

OPERATION SAFETY—PERSONAL PROTECTION

Notice

Induction appliances are more powerful, heat up pans quicker, and cook food faster than conventional cooking equipment. Your induction appliance will require different use and care than other conventional equipment.

Do not operate the equipment without reading this manual and understanding all safety requirements.

⚠ DANGER

If any part of the appliance is cracked or broken, **Stop and Immediately Turn Off the appliance.** Only if it is possible and safe, disconnect the equipment from main power supply. Do not touch any parts inside the appliance.

Disconnect electric power at the main power disconnect for all equipment being serviced.

Failure to disconnect the power at the main power supply disconnect could result in serious injury or death. The power switch DOES NOT disconnect all incoming power.

Contact an authorized service agency for assistance.

⚠ DANGER

Do not operate any appliance with a damaged or pinched cord or a damaged plug. All repairs must be performed by a qualified service company.

⚠ DANGER

Keep power cord AWAY from HEATED surfaces. DO NOT immerse power cord or plug in water. DO NOT let power cord hang over edge of table or counter.

⚠ DANGER

To avoid cardiac pacemaker malfunction, consult your physician or pacemaker manufacture about effects of electromagnetic field on your pacemaker.

⚠ DANGER

Never stand, sit, or lean on the equipment! They are not designed to hold the weight of an adult, and may collapse or tip if misused in this manner.

⚠ Warning**Short Cook Time**

Induction appliances cook food faster than conventional cooking equipment. To avoid overheating and burning, check the cooking process frequently. Never leave the appliance unattended during operation.

⚠ Caution

Metallic objects are heated up very quickly when placed on the cook zone during operation. To avoid injury, DO NOT place any objects such as closed cans, aluminum objects (aluminum foils), cutlery, jewelry, or watches on the appliance.

DO NOT place any object such as paper, cardboard, or cloth on the cooking surface, because this creates a fire hazard.

DO NOT place credit cards, phone cards, tapes, or any objects that are sensitive to magnetism on the appliance.

DO NOT use the appliance for storage. DO NOT place any paper products, cooking utensils, cutlery, plastic vessels or food on the appliance.

Notice

Do not use the cooktop for food preparation such as cutting and chopping.

⚠ Warning

Risk of burns from high temperatures. You may get burnt if you touch any of the parts during operation. Surfaces close to the cooking area including side panels may get hot enough to burn skin. Use extreme caution to avoid coming in contact with hot surfaces or hot grease. Wear personal protective equipment.

Cooking with Induction Glass-Tops Models**⚠ Warning****Never Leave An Empty Pan On Cooktop**

Induction appliances heat up empty pans very quickly. Never operate the appliance with an empty pan. Do not pre-heat pan. Always put food products, water or oil into the pan before turning on the appliance. Failure to do so will result in irreparable damage.

Notice**Broil-Dry Protection**

Cook zones are monitored by temperature sensors. The sensors can detect overheating at the base of a cooking pan.

When an overheated pan (overheated oil, empty pan) is detected, the appliance stops transferring energy to the pan immediately. You must turn off the appliance and let it cool down before re-starting the appliance.

⚠ Caution**Do Not Touch Overheated Appliance**

To avoid burn injuries, do not touch the appliance when a pan is overheated and take all the necessary precautions when removing the overheated pan.

⚠ Warning

Steam can cause serious burns. Always wear some type of protective covering on your hands and arms when removing lids or pans from the appliance. Lift the lid or pan in a way that will direct escaping steam away from your face and body.

Cooking with Induction Griddles/Braising Pans**⚠ Caution****Induction Griddles / Braising Pans**

A suitable grease-collecting means must be in place before operating appliance.

Important Rules—Operation and Maintenance

Follow these simple rules to ensure reliable and repeatable performance of your induction equipment:

1 Keep kitchen temperature below 40°C [105°F].

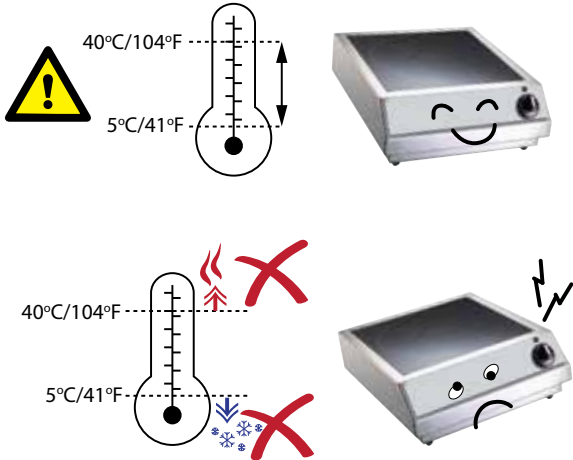

4 Use only pans that fits the glass. Do not use oversized pans.

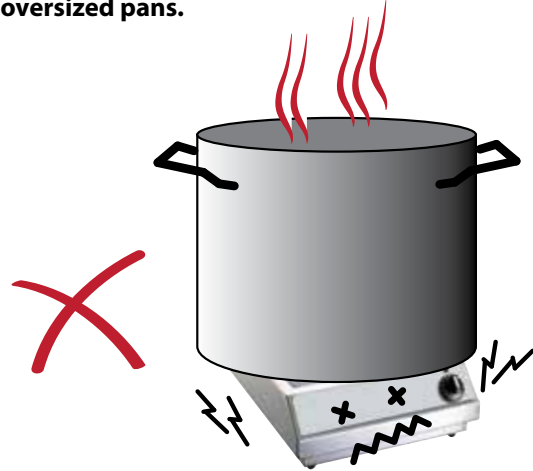

2 Never place your induction equipment next to any grease generating or heat generating equipment.

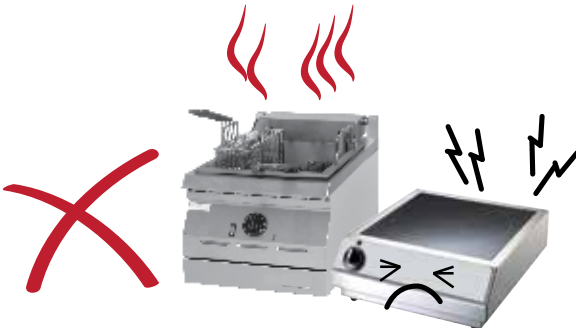

5 Never pre-heat the pan. Place the pan on the cook zone only when you are ready to cook.

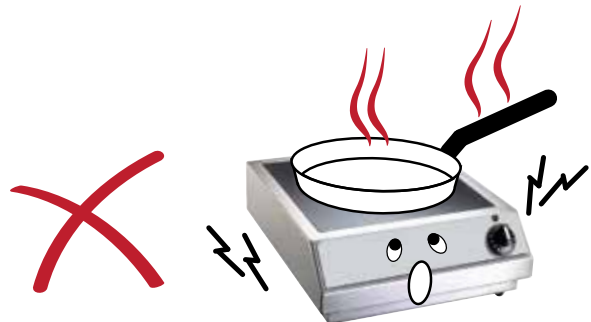

3 Clean the intake filter at least once a week or as often as required.

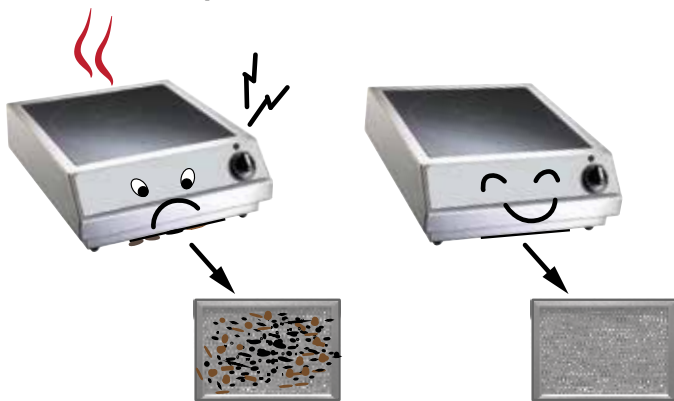

6 Do not use dented pans because it will cause damages to the electronics.

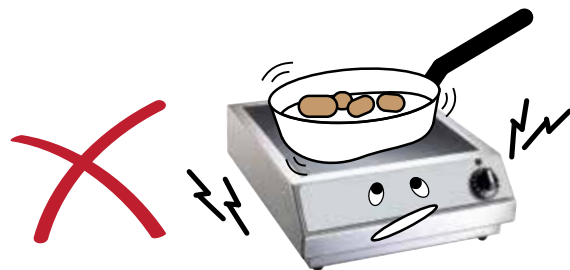

Proper Induction Cookware

CONDITION

- Pans with layer separation (outward and inward bubbles), arching or partially detached bottoms must be replaced.
- When these pans are used, the sensors under the glass-top cannot detect temperature correctly. These pans will overheat the sensors and eventually will damage the sensors and the generator. (Below, examples of good and bad pans in cross-sections.)

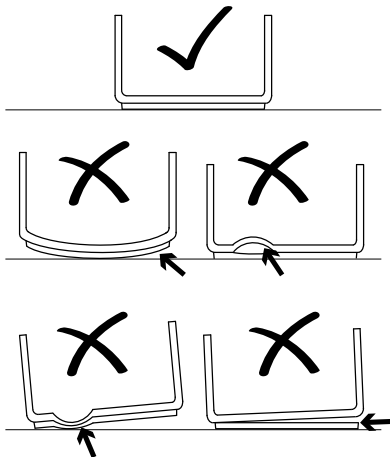

ROUND BOTTOM WOK PANS

- For models with Ceran® Glass Wok Bowls:

Notice-Wok Equipment

Use Wok Pans with Correct Contour

The wok pans used must be the correct contour to the Ceran® glass bowl. To reduce premature failures such as overheating, wok pans should not touch the glass but only sit onto the upper flange.

To guarantee the correct contour, we offer a selection of wok induction pans. Please consult your equipment supplier for details.



MATERIAL

- **USE** cookware made of **conductive and magnetic** materials. If the pan bottom attracts a magnet, the pan is suitable for induction cooking. Look for cookware that is labeled **suitable for induction** or with an induction compatible symbol.

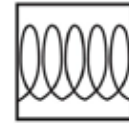

- **DO NOT USE** cookware made of aluminum, copper, glass, ceramics or conventional stainless steel.

- NOTE—Aluminum inserts on bottom:

Cookware base inserted with areas of aluminum reduces the magnetic area for induction cooking. The appliance may supply less energy to the cookware or have difficulties in detecting the pan.

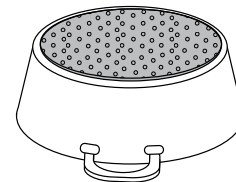

- NOTE—Non-magnetic cookware with a small magnetic base:

The exposed non-magnetic metal on the base may affect the induction field and subsequently, less energy may be supplied to the cookware.

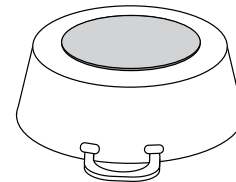

BOIL TEST

To test the efficiency of a pan for induction cooking, perform a boil test. See instructions in section 5 Troubleshooting.

SIZE OF PAN

- **MINIMUM SIZE:** The bottom of pan must have a **minimum diameter of 12cm [5"]** (below, dotted lines). Otherwise, the pan will not be heated. This is a safety feature such that the sensors do not detect small metal objects, such as jewelry, and transmit energy to heat up the small object.

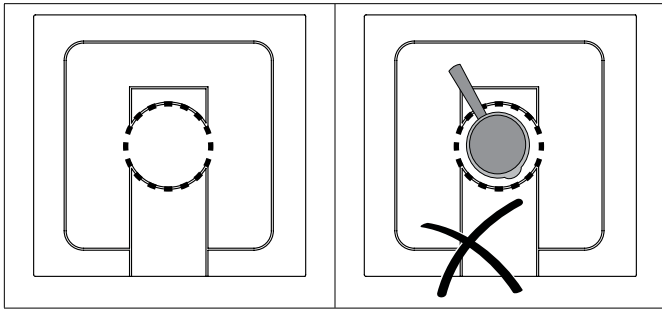

- **DO NOT USE OVERSIZED PAN!** The bottom of the pan must fit the glass. When a hot, oversized pan covers the silicone seal underneath, the heat from the pan may dry out the silicone overtime. When the silicone seal dries out and breaks, liquid can penetrate into the appliance and damage the electronics.

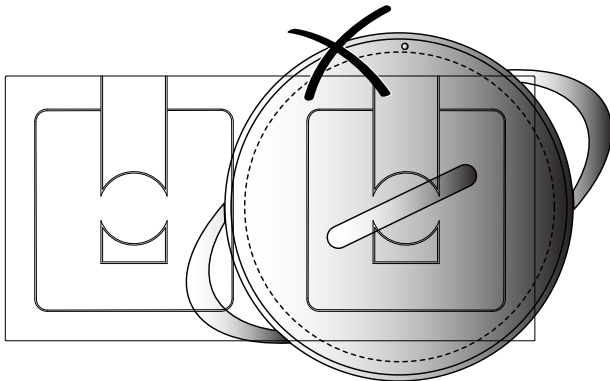

(A dual cook-top is shown as an example.)

- **PAN MUST FIT THE GLASS!** The best pan to use is the one with a bottom that fits the coil (below, dotted lines).

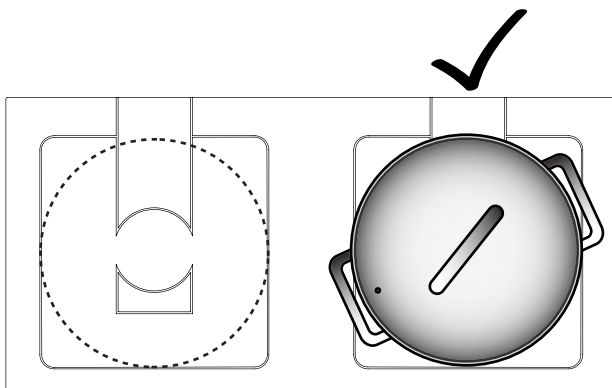

(A dual cook-top is shown as an example.)

Placing Pan On A Cook Zone

Each cook zone of our appliances is equipped with the latest RTCS® or RTCSmp® sensors. These sensors monitor temperature and cookware continuously in realtime.

To obtain optimal results from the sensors, you must **always place pan in the center of the cook zone**. Otherwise, the bottom of the pan is heated unequally and the food inside the pan may burn.

- **PLACE MAXIMUM ONE PAN PER COOK ZONE.**

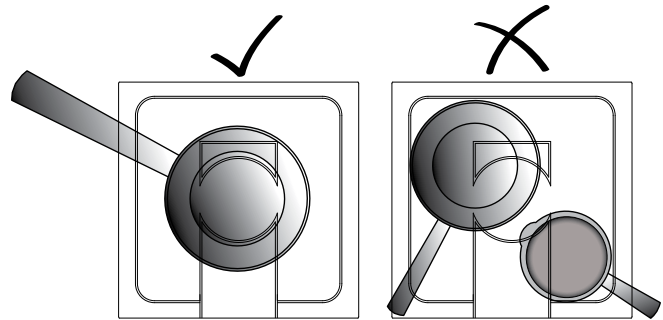

- **ALWAYS PLACE PAN IN THE CENTER OF A COOK ZONE.**

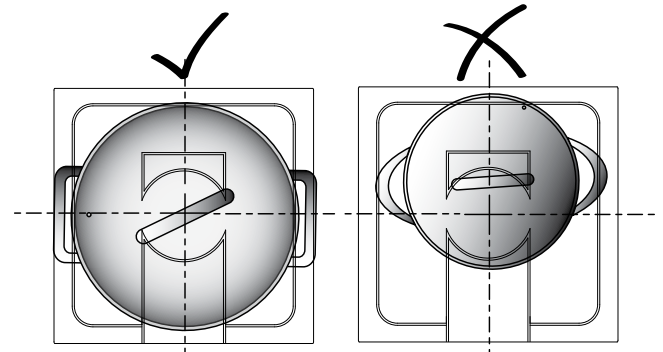

- **PAN MUST NOT COVER MORE THAN ONE COOK ZONE ON A DUAL OR ON TWO SINGLE UNITS.**

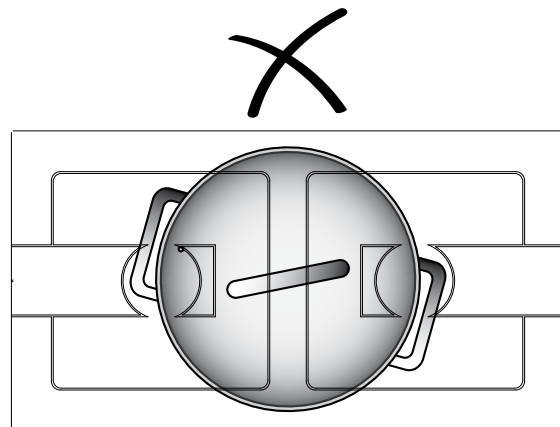

Power Control

Set the desired power level by turning the control knob and the appliance is immediately ready for operation.

- Power level (1) = lowest power
- Power level (9) = highest power for BH models only
- Power level (12) = highest power

When the indicator lamp shines continuously, energy is being supplied to the bottom of the cookware.

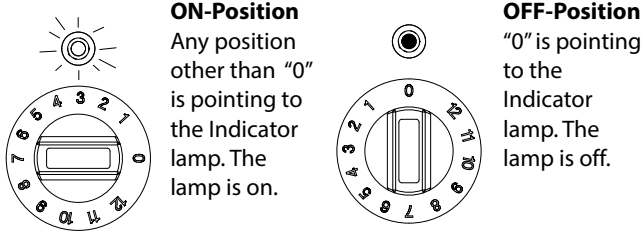

POWER LEVEL SETTINGS

The Power Diagrams (below) show that the difference in power output between two higher power levels is much larger than that between two lower power levels.

This power level and output relationship gives you a fine simmer-rate control in the low power range, and an instant response in the high power range.

POWER DIAGRAM 1: POWER LEVEL 0 TO 12

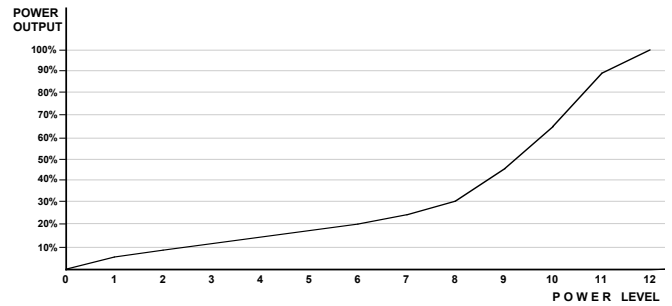

The settings from (1) to (9) span the lower 50% of the total Power Output; the settings from (10) to (12) cover the 50% to 100% output range.

POWER DIAGRAM 2: POWER LEVEL 0 TO 9

(BH models only)

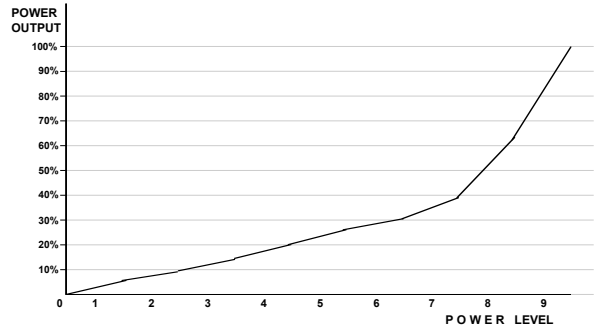

The settings from (1) to (7) span the lower 50% of the total Power Output; the settings from (8) to (9) cover the 50% to 100% output range.

Automatic Pan Detection, No Pan No Heat

When a temperature or a power level is selected, the appliance supplies energy only when a pan is placed in the cook zone.

When you remove the pan from the cook zone, the appliance stops power supply immediately. If the pan is put back in the cook zone, power supply resumes.

NOTE: Pan with a bottom diameter smaller than 12cm or 5" is not detected by the system.

Reading the Signals from An Indicator Lamp

PAN DETECTION MODE: The appliance is in Pan Detection mode when it is ON but without any pan sitting on the surface of the cook zone. The indicator lamp flashes.

As soon as a pan is put into the cook zone, the pan engages the heating process and the indicator lamp stops flashing and remains bright. However, the indicator lamp will keep flashing if the appliance is unable to detect the pan or an unsuitable pan is used.

When a fault occurs, the indicator lamp flashes at intervals. See section 5 Troubleshooting.

When Appliance Is Idle

BEST PRACTICE:

When the induction appliance is not in use, always put the control knob in the 0 (OFF) position.

Notice

Switch the appliance OFF if you take the cookware away for a while. This will prevent the heating process to start automatically and unintentionally when a pan is placed back on the heating area. If any person needs to use the induction appliance, he/she will have to turn the appliance ON intentionally.

Section 4 Maintenance

MAINTENANCE SAFETY—DISCLAIMER

⚠ DANGER

It is the responsibility of the equipment owner to perform a Personal Protective Equipment Hazard Assessment to ensure adequate protection during maintenance procedures.

⚠ Warning

A good maintenance of the appliance requires regular cleaning, care and servicing. The site-supervisor and the operator must ensure all components relevant to safety are in perfect working order at all times.

NOTE: Cleaning tools and supplies are not provided.

DANGEROUS ELECTRICAL VOLTAGE

⚠ DANGER

Do not open the appliance. Maintenance and servicing work other than cleaning as described in this manual must be done by an authorized service personnel.

⚠ DANGER

If any part of the appliance is cracked or broken, **Stop and Immediately Turn Off the appliance.** Only if it is possible and safe, disconnect the equipment from main power supply. Do not touch any parts inside the appliance.

Disconnect electric power at the main power disconnect for all equipment being serviced.

Failure to disconnect the power at the main power supply disconnect could result in serious injury or death. The power switch DOES NOT disconnect all incoming power.

Contact an authorized service agency for assistance.

MAINTENANCE SAFETY—CLEANING

⚠ Warning

Never use a high-pressure water jet for cleaning or hose down or flood interior or exterior of the equipment with water. Ensure that no liquid can enter into the equipment.

⚠ Warning

Allow heated equipment / glass surface to cool down before attempting to clean, service or move.

⚠ Warning

When cleaning the exterior, care should be taken to avoid front power switch and the electrical cords. Keep water and cleaning solutions away from these parts.

⚠ Caution

Do not use caustic cleaners on any part of the equipment. Use mild, non abrasive soaps or detergents, applied with a sponge or soft cloth.

⚠ Caution

Ensure to remove all residues of cleaning agents from the cooking surfaces. Use a clean moist cloth to wipe off any such surfaces.

⚠ Caution

Using commercial cleaning fluids or chemicals: Read the directions for use and precautionary statements before use. Pay attention to the concentration of cleaner and the length of time the cleaner remains on the food-contact surfaces or equipment surfaces.

Notice

Inspect and Clean Fresh Air Intake Filter

We strongly recommend using air intake filters in all installations to protect the equipment from grease particles. A dirty, blocked air intake filter blocks the air vent and can cause damages to the electronic components. Inspect, clean or replace the air intake filters at least once a week or as often as necessary.

⚠ Warning

Inspect Silicone Seal

When the silicone seal is broken, water penetration could cause the appliance to fail, and any malfunction could cause personal harm.

PERSONAL PROTECTION**⚠ DANGER**

All utilities (gas, electric, water and steam) must be OFF to all equipment and locked out of operation according to national/regional, as well as company approved practices during installation, maintenance and servicing. Always allow appliance to cool.

⚠ DANGER

Use appropriate safety equipment during installation, maintenance and servicing.

⚠ DANGER

Never stand, sit, or lean on the equipment! They are not designed to hold the weight of an adult, and may collapse or tip if misused in this manner.

⚠ DANGER

To avoid cardiac pacemaker malfunction, consult your physician or pacemaker manufacture about effects of electromagnetic field on your pacemaker.

⚠ Warning

Markings and warning labels mounted directly on the equipment must be observed at all times and kept in a fully legible condition.

⚠ Warning

Risk of burns from high temperatures. You may get burnt if you touch any of the parts during operation. Surfaces close to the cooking area including side panels may get hot enough to burn skin. Use extreme caution to avoid coming in contact with hot surfaces or hot grease. Wear personal protective equipment.

⚠ Caution

Use caution when handling metal surface edges of all equipment.

Daily Cleaning and Maintenance

GLASS CLEANING



NOTE: The cleaning of Ceran® glass is identical to cleaning other similar glass surfaces. You may use any regular glass cleaning products available from a hardware store.

You may use a razor blade scraper or a non-scratching sponge to remove tough residues. When scraping, place your razor blade scraper at an angle of about 20° to 30° from the glass. Then wipe clean the glass with a cleaning product.

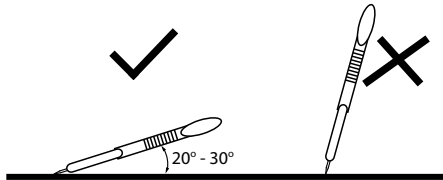

STAINLESS STEEL CASE

1. For any appliance with stainless steel case or stainless steel flange, clean the stainless steel surface using a soft cloth with a mild detergent and/or a food-safe liquid cleaner designed to clean stainless steel.
2. Wipe dry with a soft clean cloth.

VISUAL INSPECTION OF SILICONE SEAL

Inspect the silicone seal around the glass perimeter or the joint between the appliance and the counter surface. Call for service immediately if you notice:

- Cracks on the silicone seal.
- The silicone seal comes away from the glass/housing or moves when you press down on the seal.

Weekly Cleaning and Maintenance

AIR INTAKE FILTER, COUNTERTOP MODELS

1. The air intake filter is located on the bottom of the appliance. To remove, slid out the filter from the holder.

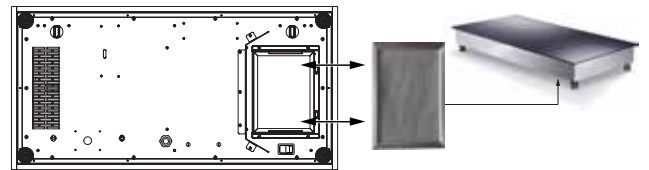
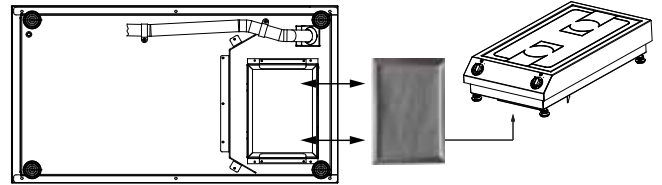
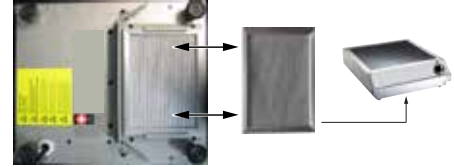

2. The filter is dishwasher-safe.

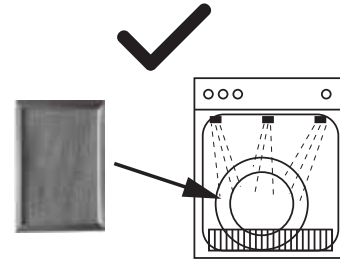

3. The filter must be DRY before you put it back into the holder.

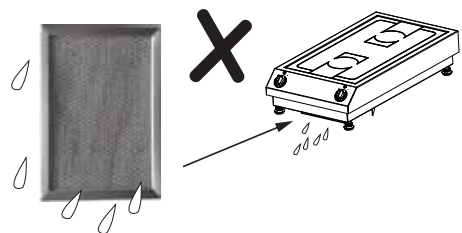
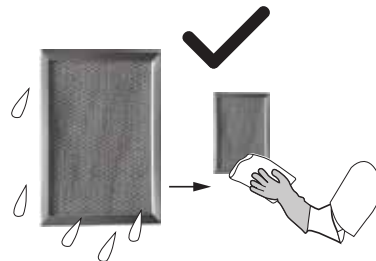

AIR INTAKE FILTER, BUILT-IN MODELS

For Air Intake Kits part numbers: 95000020, 9500021, 95000085.

1. Locate the filter, which is inserted into a holder mounted onto the cabinet.
2. When a plastic holder is used, slid out the filter from the holder.

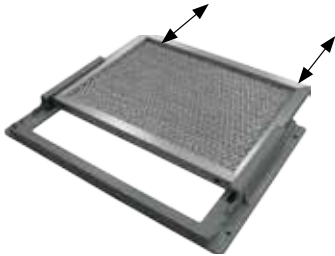

When a metallic holder is used, press down on the corners as shown to pop out the filter. If the filter doesn't move, try the opposite corners. The filter is pressure fitted into the holder.

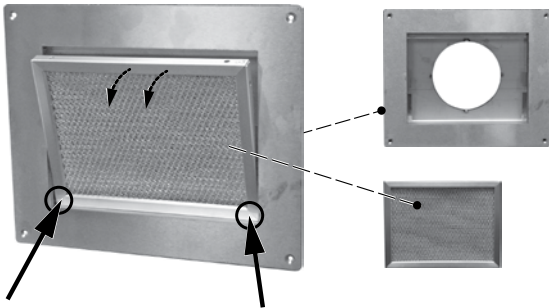

3. The filter is dishwasher-safe.

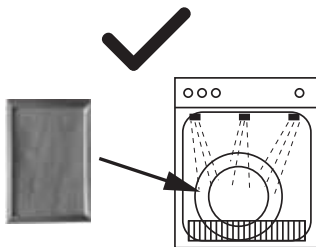

4. The filter must be DRY before you put it back into the holder.

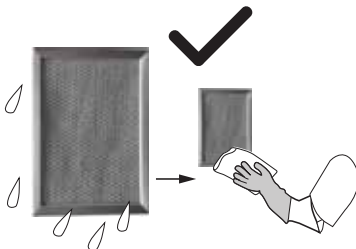
**Yearly Maintenance**

Best Practice: Have the induction appliance examined once a year by an authorized technician.

Section 5

Troubleshooting

DANGEROUS ELECTRICAL VOLTAGE

DANGER

If any part of the appliance is cracked or broken, **Stop and Immediately Turn Off the appliance**. Only if it is possible and safe, disconnect the equipment from main power supply. Do not touch any parts inside the appliance.

Disconnect electric power at the main power disconnect for all equipment being serviced.

Failure to disconnect the power at the main power supply disconnect could result in serious injury or death. The power switch DOES NOT disconnect all incoming power.

Contact an authorized service agency for assistance.

DANGER

Do not open the appliance. Maintenance and servicing work other than cleaning as described in this manual must be done by an authorized service personnel.

Warning

Markings and warning labels mounted directly on the equipment must be observed at all times and kept in a fully legible condition.

NOTE: If a problem arises during operation of your induction appliance, follow the Troubleshooting Charts before calling service. Routine adjustments and maintenance procedures are not covered by the warranty.

Common Problems

One or more of the following conditions may affect the function or cause the induction equipment to fail:

- Using unsuitable cookware such as non-induction pans, oversized pans, or damaged pans.
- High ambient temperature.
- Inadequate ventilation causing hot air to re-enter through the air intake slots.
- Dirty air intake filter.
- Empty pan is left on the hob when the appliance is ON.

Symptoms

- When a malfunction occurs, the appliance may be in one of the following states:
 - The appliance switches off immediately.
 - The appliance continues to operate in a power reduction mode.
 - The appliance continues to operate normally.
- Appliance equipped with an indicator lamp or a digital display, see section *Troubleshooting Chart — Error Code / Flash Code*.
- Appliance without an indicator lamp / digital display, or the lamp is malfunction, see section *Troubleshooting Without Error Code / Flash Code*.
- NOTE:
 - The cooling fan starts when the ambient temperature in the control area exceeds 55°C [130°F].
 - At heat sink temperature higher than 70°C [160°F], the controller automatically reduces power to keep the appliance in normal operating conditions. The cooker runs in a non-continuous mode. This mode can be heard.

Boil Test

To test the efficiency of a pan for induction cooking, perform a boil test.

This test is not applicable to griddles and braising pans. NEVER heat any cooking pan on a griddle plate or in a braising pan.

(Test for 3.5kW or 5.0kW Induction Coil)

Perform a boil test to verify the performance of a pan for induction cooking.

- Add one liter of cold water into the pan (optimal when use pan with bottom diameter of 24cm) and bring it to boil. Compare the total boil time to the guideline below:
 - 3.5kW Coil, approx. 140 seconds
 - 5.0kW Coil, approx. 85 seconds

If time to boil exceeds the above guideline, then the pan is not suitable for achieving optimal efficiency. Please contact your supplier to purchase suitable induction pans.

If the induction appliance does not function as expected despite using quality induction pans, refer to the troubleshooting charts.

Troubleshooting Without Error Code / Flash Code

Symptom	Possible Cause	Action
Pan does not heat up on glass-top. No heat to griddle or braising pan. Indicator lamp is OFF (dark). Digital display is OFF (dark).	No power supply.	Check incoming power supply (Example, power cable plugged into the wall socket). Check kitchen main fuse box.
	Control knob is in OFF-position.	Turn control knob to an ON-position.
	Defective equipment	Put knob in OFF-position. Only if possible and safe, disconnect the appliance from the power supply. Contact an authorized service agency.
Pan does not heat up and indicator lamp blinks continuously. If Indicator lamp blinks at intervals, see next section. (Not applicable to griddles or braising pans.)	Pan is too small.	Use a suitable pan with bottom diameter larger than 12cm[5"].
	Pan is not placed in the center of the hob; pan is not detected by sensor.	Move the pan to the center of the hob.
	Unsuitable pan.	Select only induction-ready cookware.
	Defective equipment	Put knob in OFF-position. Only if possible and safe, disconnect the appliance from the power supply. Contact an authorized service agency.
Poor heating, indicator lamp / digital display is ON	Air-cooling system is obstructed.	Verify that air vents are not obstructed. Ensure the fresh air filter is clean.
	Unsuitable pan. (Not applicable to griddles or braising pans.)	Select various induction-ready cookware for induction cooking. Then compare the results.
	Ambient temperature is too high. The cooling system is not able to keep the appliance in normal operating conditions.	Verify that no hot air is taken in by the fan. Reduce the ambient temperature. The intake air temperature must be lower than 40°C [104°F].
	One phase is missing (for equipment with three phase supply only).	Check incoming power supply (Example, power cable plugged into the wall socket). Check kitchen main fuse box.
	Defective equipment	Put knob in OFF-position. Only if possible and safe, disconnect the appliance from the power supply. Contact an authorized service agency.
Appliance does not react to control knob positions	Defective control switch.	Put knob in OFF-position. Only if possible and safe, disconnect the appliance from the power supply. Contact an authorized service agency.
Power/heating level seems to be reduced, fan is working	Air-cooling system is obstructed. Internal fan is dirty.	Verify that air vents are not obstructed. Ensure the fresh air filter is clean. Contact an authorized service agency.
Power/heating level seems to be reduced, fan does not work	Defective fan or fan control.	Put knob in OFF-position. Only if possible and safe, disconnect the appliance from the power supply. Contact an authorized service agency.
After a long period of continuous operation, the power/heating level seems to be reduced	Overheated induction coil; cooking area is too hot. Overheated pan. Pan is empty.	Switch the appliance off. Safely remove pan, if any. Wait until the appliance has cooled down before turning it ON again.
Small metallic objects (e.g. spoon) are heated up in the cook zone.	Pan detection function is defective.	Put knob in OFF-position. Only if possible and safe, disconnect the appliance from the power supply. Contact an authorized service agency.

Troubleshooting — Error Code / Flash Code

• **Appliance equipped with an indicator lamp:**

The indicator lamp flashes to signal a specific problem. To find the possible cause, count the number of short flashes after each long flash.

Example: “— — ...” The lamp gives a long flash for 0.6 seconds. Then it gives 4 short flashes (indicated by the dots in the example). The sequence repeats until the error is canceled.

• **Appliance equipped with a digital display:**

The display may show an error code, example: E04.

Number of Flashes (Indicator Lamp)	Error Code (Display)	Problem	Action
.....		Normal Operation.	Normal Operation.
1 “— . — . — .”	E01	Unsuitable induction cooking pan. Internal wiring/coil connection malfunction. (1)	Check pan material. Contact an authorized service agency.
2 “— .. — .. — ..”	E02	Unsuitable induction cooking pan. Coil/software overcurrent. (1)	Check pan material. Contact an authorized service agency.
3 “— ... — ... — ...”	E03	Air-cooling system obstructed. Fan malfunction. Internal heat sink overheated. (1)	Let appliance cool down. Verify that air vents are not obstructed. Check and clean air filter. Contact an authorized service agency.
4 “— — —”	E04 E17 E18 E27 E28 E41 E42 E43 E44 E45 E46	Overheated cook zone. Overheated pan detected. Sensor failure. Overheated or defective sensor. (1) NOTE: Errors E41 to E46, griddles and braising pans may continue to operate.	Let appliance and/or pan cool down. Check pan material. Verify that air vents are not obstructed. Check and clean air filter. Contact an authorized service agency.
5 “— — —”	E05	Power switch/potentiometer error. (1)	Contact your authorized service agency.
6 “— — —”	E06 E30	Ambient temperature too high (the cooling system is not able to keep the induction appliance in normal operating conditions). Internal component overheated. (1)	Let appliance cool down. Verify that air vents are not obstructed. Check and clean air filter. Verified that no hot air is taken in by the fan. Reduce the ambient temperature. The intake air temperature must be lower than 40°C [104°F]. Contact an authorized service agency.
7 “— — —”	E29 E47	Generator component failure. Problem with control wiring. Warning from overheated pan / cooking empty sensor or coil connection failed. (1) NOTE: E47 on griddles/braising pans indicates that griddle plate is too hot.	Let equipment/ pan cool down. Check food in the pan or empty pan. Contact an authorized service agency.
8 “— — —”	E21 E24 E25 E26	Sensor error from heat sink or CPU. Board overheated. Ambient temperature beyond normal operating range. (1)	Verify that air vents are not obstructed. Check air filter. Reduce ambient temperature. Contact an authorized service agency.
10 “— — —”	E10	Internal electronic failure. (1) or (2)	Contact an authorized service agency.
No flash code	E11	Multi-Line model only: 24V Voltage too low. (1).	Contact your authorized service agency to check power connection, 24V, power board and display.
No flash code	E12 E13	Power reduction. Warning of high heat sink temperature. Cook zone temperature too high. Sensor warning of high temperature. (2)	Let equipment/ pan cool down. Check pan material. Verify that air vents are not obstructed. Check and clean air filter. Verified that no hot air is taken in by the fan. Reduce ambient temperature. The intake air temperature must be lower than 40°C [104°F]. Contact an authorized service agency.
No flash code	E19 E20	Warning of high internal temperature. (2)	Let equipment/ pan cool down. Check pan material. Verify that air vents are not obstructed. Check and clean air filter. Verified that no hot air is taken in by the fan. Reduce ambient temperature. The intake air temperature must be lower than 40°C [104°F]. Contact an authorized service agency.
No flash code	E22	Griddle only. RTCS/CU sensor defect. (1)	Contact an authorized service agency.

(1) The appliance switches off immediately.

(2) The appliance continues to operate in a power reduction mode.

(3) The appliance continues to operate normally.

Wearable Parts List

Photo	Part Number	Description
	7000015	Silicone Seal PACTAN 7076, 310ml. For installation and water-tight seal.



GARLAND
1177 KAMATO ROAD, MISSISSAUGA, ONTARIO, CANADA. L4W1X4

888-442-7526
WWW.GARLAND-GROUP.COM

Every new piece of Manitowoc Foodservice equipment comes with KitchenCare™ and you choose the level of service that meets your operational needs from one restaurant to multiple locations.

StarCare – Warranty & lifetime service, certified OEM parts, global parts inventory, performance audited

ExtraCare – CareCode, 24/7 Support, online/mobile product information

LifeCare – Install & equipment orientation, planned maintenance, KitchenConnect™, MenuConnect

Talk with KitchenCare™ • 1-844-724-CARE • www.mtwkitchencare.com



To learn how Manitowoc Foodservice and its leading brands can equip you, visit our global web site at www.manitowocfoodservice.com, then discover the regional or local resources available to you.

