



## Gem-12D Digital Brewer – Instructions

### Important Safeguards/Conventions

This appliance is designed for commercial use. Any servicing other than cleaning and maintenance should be performed by an authorized Wilbur Curtis service center.

- Do NOT immerse the unit in water or any other liquid
- To reduce the risk of fire or electric shock, do NOT open top panel. No user serviceable parts inside. Repair should be done only by authorized service personnel.
- Keep hands and other items away from hot parts of unit during operation.
- Never clean with scouring powders, bleach or harsh implements.

#### Conventions



**WARNINGS – To help avoid personal injury**



**Important Notes/Cautions – from the factory**



**Sanitation Requirements**

**Your Curtis ADS System is Factory Pre-Set and Ready to Go... Right from the Carton.**

Following are the Factory Settings for your interLock Coffee Brewing Systems:

- **Brew Temperature** = 200°F
- **Water Bypass** = ON - Recommended, 36 cup brew
- **Brew Volume** = Set to 36 cup vessel requirements.
- **Sleep Mode** = Off

System Requirements:

- **Water Source** 20 – 100 PSI (Minimum Flow Rate of 1 GPM)
- **Electrical:** See attached schematic for standard model or visit [www.wilburcurtis.com](http://www.wilburcurtis.com) for your model.

### SETUP STEPS

The unit should be level (left to right and front to back), located on a solid counter top. Connect a water line from the water filter to the brewer. NOTE: Some type of water filtration device must be used to maintain a trouble-free operation. (In areas with extremely hard water, we suggest that a sedimentary and taste & odor filter be installed.) This will prolong the life of your brewing system and enhance coffee quality.



The National Sanitation Foundation requires the following water connection:

1. A quick disconnect or additional coiled tubing (at least 2x the depth of the unit) so that the machine can be moved for cleaning underneath.
2. In some areas an approved backflow prevention device may be required between the brewer and the water supply.

1. A 3/8" NPT x 1/4" Flare elbow has been supplied for water line connection. Use tubing sized sufficiently to provide a minimum of 1.0 GPM.
2. To hookup the InterLock grinder, Locate the jack labeled "Class 2 Wiring Only" on brewer and grinder. Connect the two with the cable plug.
3. Connect the unit to an appropriate electrical power circuit.
4. Turn on the toggle (STANDBY/ON) switch behind the unit. The heating tank will start to fill. When the water level in the tank rises to the correct volume, the heating elements will energize automatically. With ADS Systems there is no danger of element burnout caused by an empty tank.
5. The heating tank will require 20 to 30 minutes to reach operating temperature (200°F) as indicated by the READY-TO-BREW indicator.
6. Prior to brewing, dispense 12 ounces of hot water through the hot water faucet.
7. Brew a cycle of at least 12 ounces, to purge the water lines of any air that may be trapped after filling.

### BREWING INSTRUCTIONS

1. Brewer should be ON (Confirm at rear toggle switch, then press the ON/OFF button). Ready-to-Brew should be ON.
2. Place an empty Satellite on the warmer deck, under the brewcone and press the warmer switch.



3. Place a clean filter into the brewcone.



4. Fill brewcone with ground coffee.

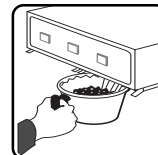

5. Transfer filled brewcone to brewer.

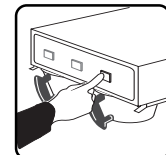

6. Press Brew button. Brewing will begin immediately.

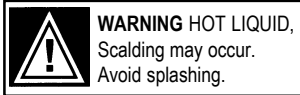

**WARNING HOT LIQUID.**  
Scalding may occur.  
Avoid splashing.



**CAUTION:** Please use this setup procedure before attempting to use this brewer. Failure to follow the instructions can result in injury or the voiding of the warranty.

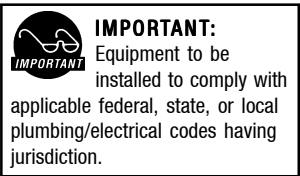

**IMPORTANT:** Equipment to be installed to comply with applicable federal, state, or local plumbing/electrical codes having jurisdiction.

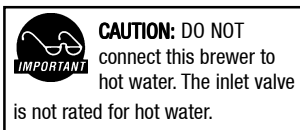

**CAUTION:** DO NOT connect this brewer to hot water. The inlet valve is not rated for hot water.



**WARNING TO AVOID SCALDING.** Do not remove brewcone while brew light is flashing.



ISO 9001 REGISTERED

WILBUR CURTIS COMPANY  
Montebello, CA 90640

# STEPS TO PROGRAMMING

**WARNING** These steps involve working with hot water. Scalding may occur if care is not taken against spilling.

## PROGRAMMING ONLY REQUIRED IF FACTORY SETTINGS MUST BE CHANGED

**IMPORTANT** – Before entering the program mode, allow the unit to reach brewing temperature, then press the BREW button to dispense at least 12 ounces of water to clear any air that may be trapped within the water lines.

**NOTE:** For ALL functions you must first enter the programming mode.

### Brew Temperature – Factory Pre-Set to 200°F







Function to set brew temperature, 170° to 204°F. Brew temperature will be indicated by READY-TO-BREW light blinking.

#### ENTERING THE PROGRAM MODE #1

- Turn OFF the power from the Control Panel by pressing .
- Press and HOLD  and press and RELEASE .
- Continue HOLDING  until  starts blinking; RELEASE.

#### CONFIRM/RESET BREW TEMPERATURE - Factory Preset to 200°



ENTER THE PROGRAMMING MODE #1:

- Press  for two seconds, then RELEASE.
-  will start blinking. Each blink equals 2° F, starting at 170°.
- To change Temperature, press and HOLD .
-  will start QUICK flashing. Each QUICK flash equals 2° F. After reaching 204°, temperature starts over at 170°.
- RELEASE  when the desired temperature is reached.
- To set and exit, press .

### BREW VOLUME - Factory Preset to Brewer Requirements



#### CHANGE BREW VOLUME

ENTER THE PROGRAMMING MODE #1

- Press and HOLD  until hot water starts running from sprayhead; then RELEASE.
- When desired volume is reached, press  again to stop flow.
- To set and exit, press .

### BREW CYCLE COUNTER

#### ENTER THE PROGRAM MODE #2

- Turn OFF the power from the Control Panel by pressing .
- Press and HOLD  and press and RELEASE .
- Continue HOLDING  until  STOPS blinking; RELEASE.

#### TO ACCESS BREW CYCLE COUNTER

ENTER THE PROGRAMMING MODE #2:

-  will now start a pattern of LONG and SHORT blinks.
- This pattern identifies the number of brew cycles. SHORT blinks indicate the brew number from one [1] to nine [9]. LONG blinks separate the 1's, 10's, 1,000's and 10,000's.

### SLEEP MODE (220V Models Only) – Factory Preset to Disabled



This function conserves energy by automatically reducing tank temperature to 140° F when the unit sits idle for more than two hours. To recover, simply press any BREW (or Grind button if InterLocked) or ON/OFF button. Once the water in the tank reaches brewing temperature, the brew cycle will automatically start. Recovery is indicated by a yellow RECOVERY light on the membrane control panel. Recovering from a SLEEP mode is faster and more efficient than heating after switching off the power.

#### SLEEP MODE – Factory Preset to DISABLED

To ENABLE Sleep Mode:

- UNIT MUST BE ON. Press and HOLD  until **SLEEP** light turns ON; press  again. Sleep Mode is now ENABLED.

To DISABLE Sleep Mode:

- UNIT MUST BE ON. Press and HOLD  until **SLEEP** light turns OFF; press  again. Sleep Mode is now DISABLED.

### WARMERS

#### Adjusting the Temperature

Gemini Warmers feature three temperature settings. Warmers are rated at 100W with High (100%); Med (60%); Low (30%).

Pressing the WARMER button once will place it on HIGH; A second time MED; Third time LOW as indicated by the warmer lights. A fourth press of the warmer button turns off the warmer.

When the system is turned off at the ON/OFF button, it will remember the last warmer setting. Additionally, if the warmer is off, the unit is designed to automatically turn the warmer on (MED setting) when the next brew cycle is started.

### BYPASS FLOW ADJUSTMENT

1. Slide brew cone out to expose bypass outlet. Place one measuring cup under the bypass fitting, and another measuring cup under the brew cone outlet. Press the LARGE brew button for 15 seconds, then press the ON/OFF button to stop the brew cycle.
2. Divide the number of ounces collected from the bypass outlet into the total ounces collected from the sprayhead and bypass. This will determine the percentage of bypass.
3. To increase or decrease the volume of bypass water, turn the adjustment screw on the bypass valve as indicated. Clockwise for less water; counterclockwise for more water.
4. You must reprogram the brew volume to maintain the proper total amount of coffee brewed into the insulated server. Reprogramming is required every time you make a bypass adjustment or change to a different sprayhead.

# PARTS DIAGRAMS GEM-12D

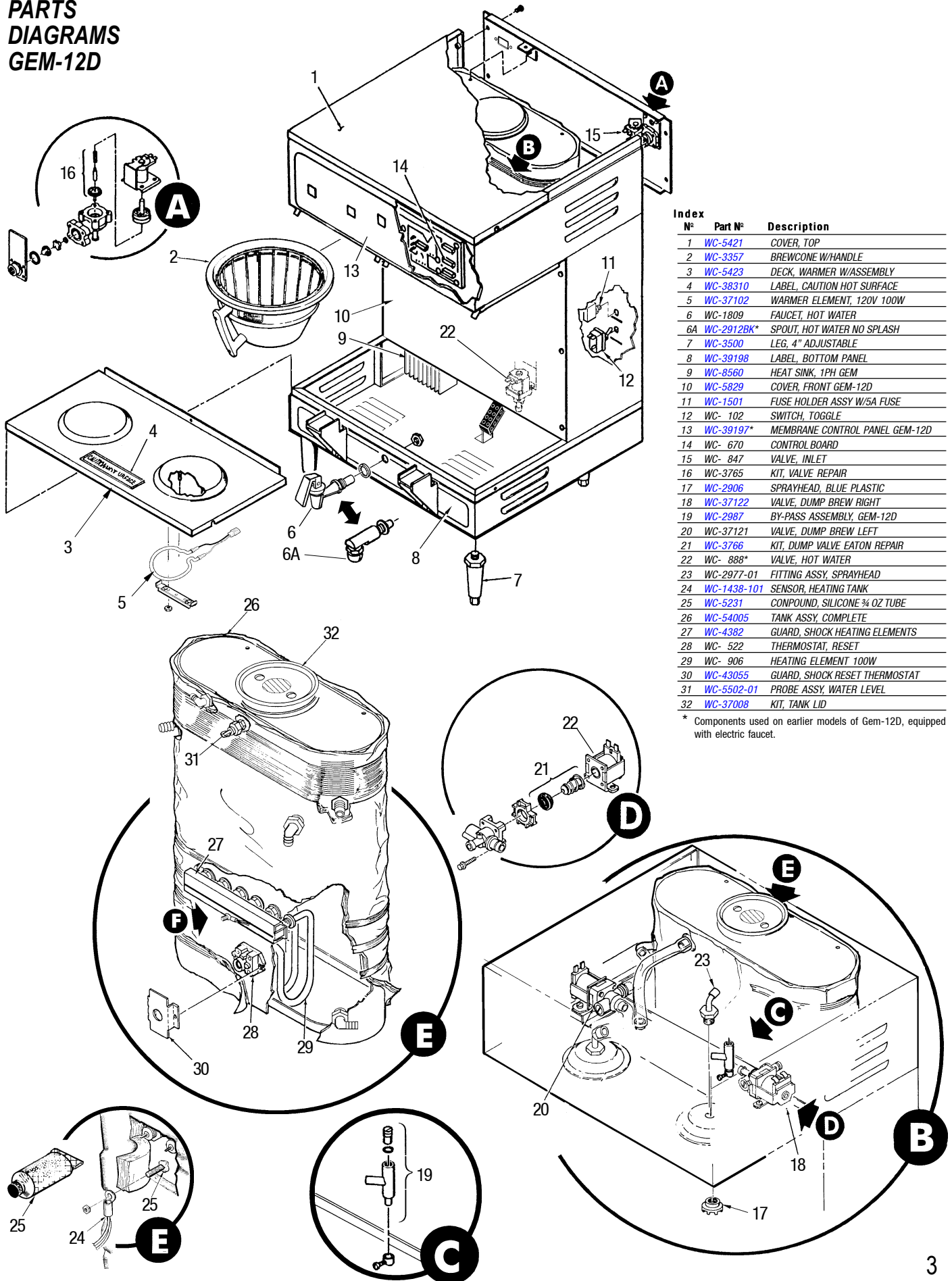

Index N°	Part N°	Description
1	WC-5421	COVER, TOP
2	WC-3357	BREWCONE W/HANDLE
3	WC-5423	DECK, WARMER W/ASSEMBLY
4	WC-38310	LABEL, CAUTION HOT SURFACE
5	WC-37102	WARMER ELEMENT, 120V 100W
6	WC-1809	FAUCET, HOT WATER
6A	WC-2912BK*	SPOUT, HOT WATER NO SPLASH
7	WC-3500	LEG, 4" ADJUSTABLE
8	WC-39198	LABEL, BOTTOM PANEL
9	WC-8560	HEAT SINK, 1PH GEM
10	WC-5829	COVER, FRONT GEM-12D
11	WC-1501	FUSE HOLDER ASSY W/5A FUSE
12	WC- 102	SWITCH, TOGGLE
13	WC-39197*	MEMBRANE CONTROL PANEL GEM-12D
14	WC- 670	CONTROL BOARD
15	WC- 847	VALVE, INLET
16	WC-3765	KIT, VALVE REPAIR
17	WC-2906	SPRAYHEAD, BLUE PLASTIC
18	WC-37122	VALVE, DUMP BREW RIGHT
19	WC-2987	BY-PASS ASSEMBLY, GEM-12D
20	WC-37121	VALVE, DUMP BREW LEFT
21	WC-3766	KIT, DUMP VALVE EATON REPAIR
22	WC- 888*	VALVE, HOT WATER
23	WC-2977-01	FITTING ASSY, SPRAYHEAD
24	WC-1438-101	SENSOR, HEATING TANK
25	WC-5231	COMPOUND, SILICONE ¼ OZ TUBE
26	WC-54005	TANK ASSY, COMPLETE
27	WC-4382	GUARD, SHOCK HEATING ELEMENTS
28	WC- 522	THERMOSTAT, RESET
29	WC- 906	HEATING ELEMENT 100W
30	WC-43055	GUARD, SHOCK RESET THERMOSTAT
31	WC-5502-01	PROBE ASSY, WATER LEVEL
32	WC-37008	KIT, TANK LID

\* Components used on earlier models of Gem-12D, equipped with electric faucet.

# Electrical Schematics

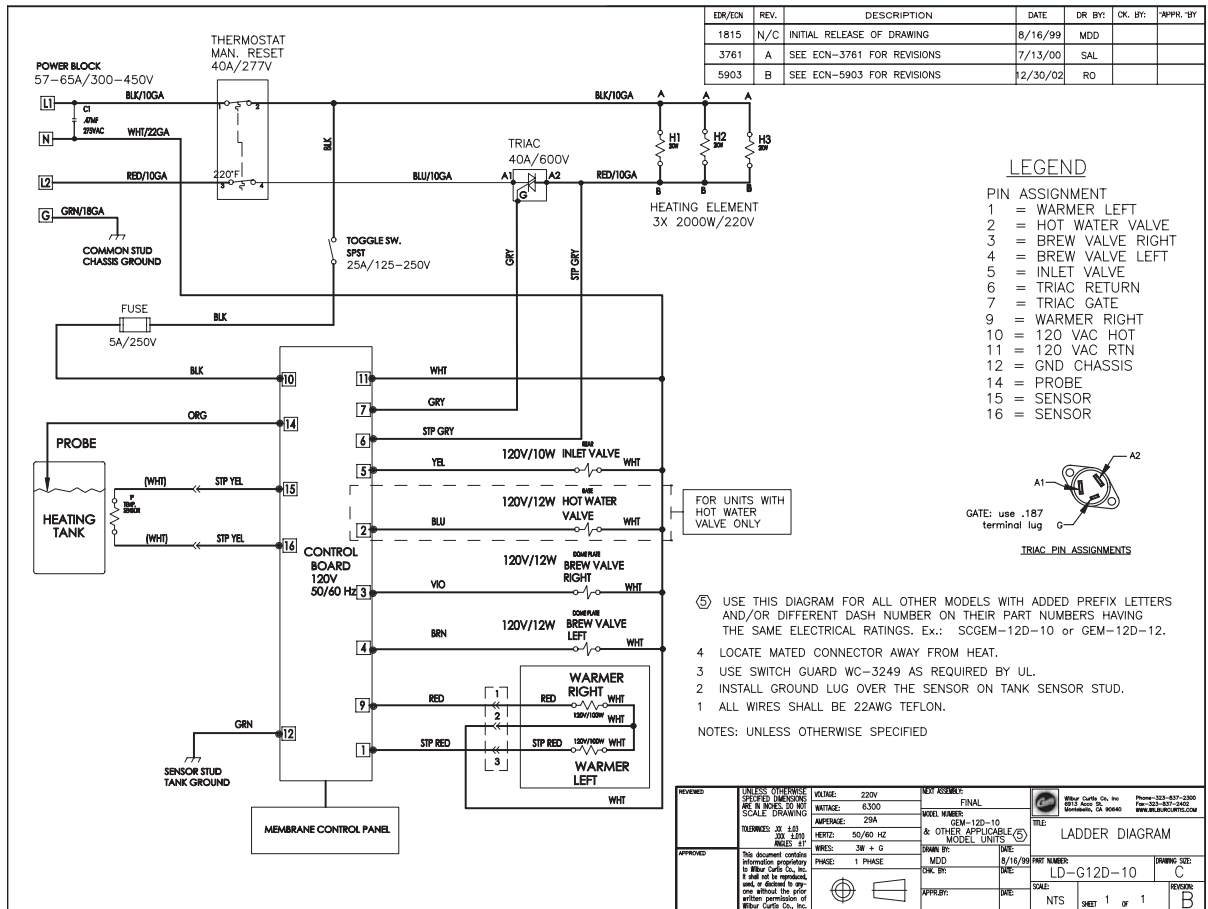

## WARRANTY We hereby certify that the products manufactured by the Wilbur Curtis Company, Inc., are, to the best of our knowledge, free from all defects and faulty workmanship.

The following warranties and conditions are applicable:

- **90 Days for Labor and 1 Year Parts from Date of Purchase from Factory:** This warranty covers all electrical parts, fittings and tubing.
- **40 Months or 40,000 Pounds of Coffee from a set of Grinding Burrs. (ADS Grinders)**
- **2 Years from Date of Purchase:** This warranty covers electronic control boards and leaking or pitting of a stainless steel body of a Brewer or Um.
- **90 Days from Date of Purchase:** On replacement parts that have been installed on out of warranty equipment

All in-warranty service calls must have prior authorization from the manufacturer. For an RMA (Return Merchandise Authorization) number, call the Technical Service Department at 1-800-995-0417. The Wilbur Curtis Company will allow up to 100 miles, round trip, per in-warranty service call.

### CONDITIONS & EXCEPTIONS

The warranty covers original equipment at time of purchase only. The Wilbur Curtis Company, Inc., assumes no responsibility for substitute replacement parts installed on Curtis equipment that have not been purchased from the Wilbur Curtis Company, Inc. The Wilbur Curtis Company will not accept any responsibility if the following conditions are not met. The warranty does not cover and is void under these circumstances:

- 1) Improper operation of equipment. The equipment must be used for its designed and intended purpose and function.
- 2) Improper installation of equipment. This equipment must be installed by a professional, certified technician and must comply with all local electrical, mechanical and plumbing codes.
- 3) Wilbur Curtis Company will not be responsible for the operation of equipment at other than the stated voltages on the serial plate.
- 4) Abuse or neglect (including failure to periodically clean or remove lime accumulations). Manufacturer is not responsible for variation in equipment operation due to excessive lime or local water conditions.
- 5) Replacement of items subject to normal use and wear. This shall include, but is not limited to, light bulbs, shear disks, "O" rings, gaskets, canister assemblies, whipper chambers and plates, mixing bowls, agitation assemblies and whipper propellers.
- 6) Any faults resulting from inadequate water supply. This includes, but is not limited to, excessive or low water pressure, and inadequate or fluctuating water flow rate.
- 7) All repairs and/or replacements are subject to our decision that the workmanship or parts were faulty and the defects showed up under normal use.
- 8) All labor shall be performed during regular working hours. Overtime charges are the responsibility of the owner.
- 9) Charges incurred by delays, waiting time, or operating restrictions that hinder the service technician's ability to perform service is the responsibility of the owner of the equipment. This includes institutional and correctional facilities.
- 10) All claims under this warranty must be submitted to the Wilbur Curtis Company Technical Service Department before return of the unit to the factory.
- 11) All equipment returned to us must be repackaged properly in the original carton. No units will be accepted if they are damaged in transit due to improper packaging.
- 12) Damaged in transit.
- 13) The resetting of safety thermostats and circuit breakers, programming and temperature adjustments are the responsibility of the equipment owner.

**NO UNITS OR PARTS WILL BE ACCEPTED WITHOUT A RETURN MERCHANDISE AUTHORIZATION (RMA). RMA NUMBER MUST BE MARKED ON THE CARTON OR SHIPPING LABEL.**

All in-warranty service calls must be performed by an authorized service center, where service is available. Call the factory for location near you.



### WILBUR CURTIS CO., INC.

6913 Acco St., Montebello, CA 90640-5403 USA  
 Phone: 800/421-6150 ♦ Fax: 323-837-2410

♦ Technical Service Phone: 800/995-0417 (M-F 5:30A - 4:00P PST) ♦ E-Mail: techservice@wilburcurtis.com  
 ♦ Web Site: www.wilburcurtis.com

FOR THE LATEST SPECIFICATION INFORMATION GO TO WWW.WILBURCURTIS.COM