



OPERATING INSTRUCTIONS

TOP MOUNT HEATED HOLDING



**Heated Holding Food Warmers
With Dial Face Controls
or HDM Controls**

FWE TOP MOUNT HEAT SYSTEM

***FWE Heated Holding Cabinets
Keep your food "oven fresh" longer!***



PST-32



PST-16



TST-13D

Shown with optional
Lexan door

CONGRATULATIONS...

...and thank you for purchasing an FWE Top Mount heated serving cabinet. Your unit has been designed and manufactured under rigid controls to assure you the most efficient service. It is a full time unit, and may be used continuously.

Please take a moment to read through this booklet of important information pertaining to your cabinet. By following a routine of proper use and care described on the following pages, your cabinet will last for many years.

IMPORTANT: Your **Manufacturer Registration Card** must be returned within 30 days after initial delivery to activate the warranty.

FWE TOP MOUNT MOBILE HEATED CABINETS

INSTALLATION AND CARE

SERIAL AND MODEL NUMBER

These numbers are found on the nameplate (serial tag) affixed to the unit by the electrical cord. Please record them in this booklet, in the space provided on page 5. When ordering parts and/or service, you will need to provide this information. The voltage and amperage of the unit are also stamped on the serial tag.

UNPACKING

After uncrating your cabinet, remove all tape and padding which held all doors, shelves, racks, cord, etc., in place during shipment.

ELECTRICAL REQUIREMENTS AND GROUNDING

FWE standard models operate on 110/120 volt, 60 Hz, 1 ph, A.C. (unless ordered otherwise), and are equipped with a three prong grounding cord plug for your protection against possible shock hazards. Be sure to plug only into a properly grounded three prong wall receptacle. If you have any questions with regard to adequate wiring or grounding in your building, a qualified electrician should be contacted before using your cabinet. The amperage of your cabinet is stamped on the serial tag attached to the unit.

DO NOT, UNDER ANY CIRCUMSTANCES, CUT OR REMOVE THE GROUNDING PRONG FROM THE CORD PLUG.

WARNING: ONLY A QUALIFIED ELECTRICIAN SHOULD ATTEMPT TO REPAIR OR REPLACE ELECTRICAL COMPONENTS OR WIRING.

BE SURE THAT MODEL IS UNPLUGGED FROM ELECTRICAL SOURCE BEFORE REMOVING CONTROL PANEL.

FIVE TOP MOUNT MOBILE HEATED CABINETS

CARE AND CONTROLS

CLEANING

Keep your cabinet clean by simply wiping the interior and exterior, as needed, with a damp cloth or sponge and a mild soapy solution.

NEVER USE ABRASIVES, ACIDS, OR STRONG CLEANERS.

Do not flood or allow electrical parts to become wet. The interior tray slide assemblies and humidifier pans are removable for easy cleaning.

A stainless steel cleaner/polish is recommended for the exterior to maintain a "like-new" appearance.

DO NOT USE WAX OR STRONG CLEANERS ON DOOR GASKETS OR VINYL TRIM.

CONTROLS

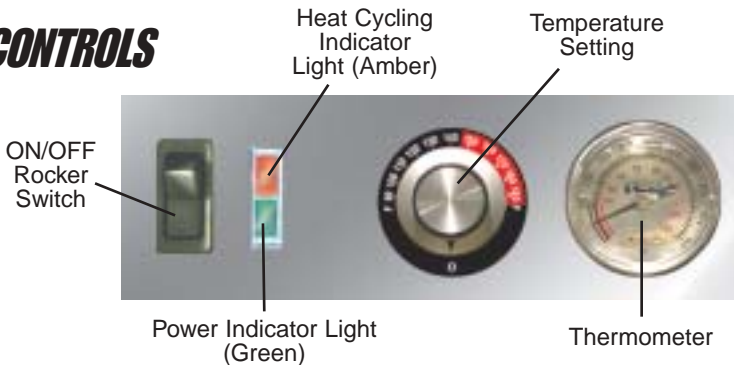

The control panel is equipped with an adjustable thermostat (to 190°F) for temperature selection, an operational range thermometer to show the actual internal temperature of the cabinet, a 20 amp ON/OFF rocker switch, a green power indicating light to tell you when the cabinet is on, and an amber indicating light that illuminates when the heating element is activated and cycling.

Your cabinet may have been custom ordered with Protected Security Controls or Hidden Controls are pre-set at factory.

GENERAL OPERATING INSTRUCTIONS

PRE-HEAT CABINET BEFORE LOADING FOOD

1) PLUG CABINET INTO A PROPERLY GROUNDED POWER RECEPTACLE. Press ON/OFF switch to “ON” position. The red indicating light will come on and remain on until power switch is turned to “OFF”, or the unit is unplugged.

2) SELECT A TEMPERATURE SETTING. For most foods, a holding temperature of 150° - 160°F should be adequate.

3) FOR BEST RESULTS, PRE-HEAT CABINET FOR 30 MINUTES, HEATING UP THE INTERIOR STAINLESS STEEL WALLS.

When the cycling light goes off, the cabinet “air” has reached the temperature which you selected in step 2. By pre-heating cabinet at least 30 minutes, even after the cycling light has gone off, you are heating up the stainless steel wall interior. This retains cabinet heat for faster recovery times.

By thoroughly pre-heating the unit before each use, you heat up the interior stainless steel and obtain the best holding results from your cabinet.

Note: Preheat longer for double-door cabinets.

4) LOAD THE CABINET. During the loading procedure, keep the doors closed as much as possible. After loading is completed, do not open doors again until you are ready to serve.

Load cabinet with your **HOT** foods.

GENERAL OPERATING INSTRUCTIONS

PUT HOT FOOD INTO A HOT CABINET

5) TRANSPORTING HOT FOODS. Your cabinet is equipped with a positive transportation latch to assure safety during transportation. Before moving the cabinet, keep it plugged in and wait until the amber cycling light goes off. This recovery takes only a short time, and allows the internal temperature to again reach the setting you have selected. As soon as the cycling light goes off, unplug the cabinet and wheel to serving area. Plug the cabinet into an electrical outlet at the serving location (if available), so that the thermostat will re-activate and automatically hold your pre-selected temperature.

**CAUTION:
HOLDING FOOD AT
TEMPERATURES OF
LESS THAN 140°F
MAY BE DANGEROUS.**

**TEMPERATURES
UNDER 140°F
PROMOTE THE GROWTH
OF HARMFUL BACTERIA
AND TOXINS IN
SOME FOODS.**

PARTS LIST

FIVE PARTS DEPARTMENT: 815 459 7500

CASTERS

5" rigid
5" swivel with brake

PART NUMBER

CSTR 5 R-2
CSTR 5 SB-2

HARDWARE

Push handle, aluminum bar, 12.5"
Push handle, aluminum bar, 21.5"
Spacers for push handles
Bolts, hex head for handles
Door gasket (by the foot)
Bumper insert, black vinyl

HDL 12.5 AL
HDL 21.5 AL
SPCR125x.330
B1/4-20x32NZ
GSKT DR
BMPR INSERT

CONTROL PANEL COMPONENTS

ON/OFF rocker switch, unlighted
Pilot light, green & amber
Knob for thermostat (Pointer)
Thermometer

SWH RCK E1
LT PLT A/G
KNB H6
T-METER H1

TRAY SLIDES

Tray slides, pair (TST models)
Tray slides, pair (UHST models)

SLD TS245
SLD UHS245

Other Replacement Parts are available. Your Model Number and Serial Number are required when requesting Parts or Service. These numbers are listed on your Serial Tag located by the power cord.

TROUBLE-SHOOTING CHART

Check this list first before you call for service...

PROBLEM	POSSIBLE CAUSE	REMEDY
TEMP TOO HOT	1A] Adjustable thermostat set too high 1B] Thermostat needs re-calibrating**	1A] Set thermostat at a lower temperature (no lower than 140°F). 1B] Loosen screw in thermostat knob and remove knob. Adjust set screw in hollow stem with small blade screwdriver by turning CLOCK-WISE . 1/4 turn lowers temperature approximately 10°F. DO NOT REMOVE SET SCREW.
TEMP NOT HOT ENOUGH	2A] Opening door unnecessarily 2B] Thermostat set too low 2C] Cord plug pulled out from outlet 2D] Fuse blown - no power to outlet 2E] Thermostat out of calibration**	2A] Keep door closed and latched shut as much as possible. 2B] Set thermostat at a higher temperature. 2C] Replug cord into proper outlet. 2D] Have a qualified electrician check power and fuse box. 2E] Loosen set screw in thermostat knob and remove knob. Adjust set screw in hollow stem with small blade screwdriver by turning COUNTER-CLOCKWISE . 1/4 turn raises temperature approximately 10°F. DO NOT REMOVE SET SCREW.
NO HEAT AT ALL	3A] Cabinet not plugged into outlet 3B] Thermostat knob at " OFF " 3C] Rocker switch at " OFF " position 3D] Fuse Blown - no power to outlet 3E] Thermostat needs replacing 3F] Heating element burned out*	3A] Plug cabinet into properly grounded electrical outlet. 3B] Adjust thermostat knob to temperature setting required. 3C] Turn switch to " ON " position. 3D] Have a qualified electrician check power to fuse box. 3E] Unplug cabinet from electrical source. Loosen set screw in thermostat knob and remove knob. Remove control panel, disconnect wires from terminals on thermostat, and remove 2 screws holding thermostat to control panel. Replace thermostat with new one, and re-install control panel and thermostat knob. 3F] Unplug cart from electrical source. Remove screws holding heating element in place. Gently pull element away from back wall a few inches to expose wire connections. Disconnect wires, and replace element with new one. Reconnect wires, secure element with screws.

** NOTE: CALIBRATION IS EXCLUDED FROM FWE WARRANTY. Thermostats on all units are calibrated at the factory prior to shipping. Due to conditions in transit, beyond our control, occasionally units will need to be re-calibrated prior to use. This is a simple procedure for which instructions are given above. (1B, 2E)

* Heating element will either function or not function. Only a slight warmth indicates a problem with the thermostat, not the element.

FWE TOP MOUNT MOBILE HEATED CABINETS

WIRING DIAGRAM

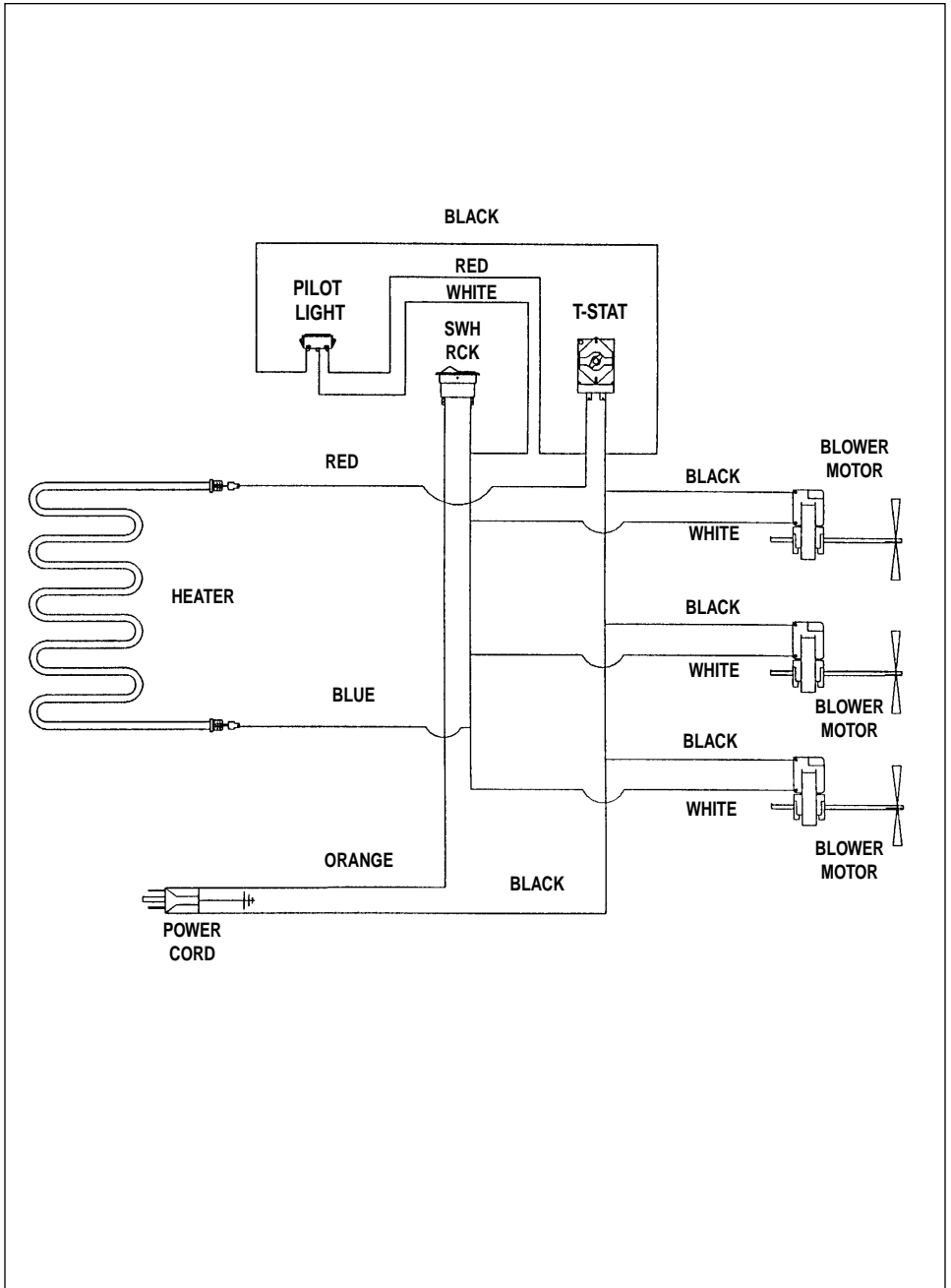

FWE TOP MOUNT MOBILE HEATED CABINETS

LIMITED TWO YEAR WARRANTY

FWE / Food Warming Equipment Company, Inc. (Seller) warrants to the original purchaser, subject to the exceptions and conditions below, that FWE manufactured equipment shall be free from defects in material or factory workmanship, under ordinary use for the purpose for which it is designed. The effective warranty period is as follows:

PARTS: Seller will furnish without charge to the original purchaser, FOB Sellers' factory, replacement parts for repairs to all new standard catalog products and factory custom / modified units, which in Seller's sole judgement, prove defective in materials or workmanship under normal and proper use with the reserved right to request the return of any part claimed to be defective, prior to issuing replacement part or authorizing warranty service, for a period of two (2) years from date of original shipment from Seller's plant, *except for equipment used in a **Correctional Environment / Facilities**, which is warranted for a period of one (1) year from date of original shipment from Seller's plant.*

LABOR: Seller's labor warranty shall be performed by a Seller-approved Service Agency who must contact Seller to obtain a Warranty Service Authorization (WSA) number prior to performing any repairs. If service is required during overtime periods, the difference between overtime and standard labor rates shall be paid by the purchaser. Seller does not assume any responsibility for any charges not expressly authorized, incidental to the repair or replacement of equipment covered by this warranty, nor charges exceeding, in Sellers sole judgement, normal and customary amounts. Only approved travel charges will be allowed. Seller's labor warranty shall be from the date of original shipment date from Seller's plant for a period of one (1) year, *except for equipment used in a **Correctional Environment / Facilities** which is warranted for a period of six (6) months.*

This warranty is for normal usage and does not apply to any product or parts thereof that have been misused, altered, or where Seller's operating instructions or specific voltage is not observed; nor shall this warranty apply to defective products or parts resulting from accident following date of original shipment, nor extend to or cover removal, installation, reinstallation or calibration, or service calls or cost of repairs undertaken by a customer. This warranty is also subject to the following:

- 1.] Customer returning the warranty registration card, accompanying Sellers original shipment, to Seller within thirty (30) days of receipt;
- 2.] Giving immediate notice of any allegedly defective part or product to Seller; and
- 3.] Customer, at Sellers request, returning said defective parts or product to Seller.

This is the sole warranty applicable to the merchandise. It is expressly understood that Seller's liability hereunder is limited to the repair or replacement, at Seller's option, of products or parts, defective materials or workmanship as provided above. Seller's judgement as to the cause and nature of any defect will be final. Seller shall in no case be responsible for special or consequential damages or any other obligation or liability with respect to products sold by Seller.

This warranty, as stated above, applies to equipment installed in the Continental United States. FWE equipment installed outside the Continental United States shall carry parts coverage only. All labor costs are approved on a discretionary basis, based on like repairs in the Continental U.S. This warranty shall stand in whole or in part as allowed by law. Any exclusion of a part of this warranty, as may be allowed by law, shall not void balance of warranty.

This is a limited warranty pursuant to the Consumer Product Warranties Act, 15 U.S. Code. section 2303.
© 2003 Food Warming Equipment Co., Inc.

The best designed . . .
The best built . . .
The best performing units on the market!



◇ Retherm Cabinets

◇ Self-Propelled Transports

◇ Heated Banquet Cabinets

◇ Universal Bulk Food Cabinets



◇ Utility Carts

◇ Refrigerators, Freezers and Convertibles

◇ Prisoner & Correctional Tray Delivery



◇ Hospital Tray Delivery Carts

◇ Portable Bars and Back-ups

FWE[®]

WE OFFER SALES AND SERVICE WORLDWIDE

Food Warming Equipment Company, Inc.

P.O. Box 1001

Crystal Lake, IL 60039-1001

Manufacturing Facilities:

7900 S. Route 31

Crystal Lake, IL 60014

FWE Parts Department:

815 459 7500

Errors subject to correction. All specifications
subject to change without notice.
© 08 Food Warming Equipment Company, Inc.

FAX:

815 459 7989