

Grill Grease Caddy

■ Model: LS3-60-EU-GG



March 2024 Edition

Table of Contents

- General Information** 3
 - Overview 3
 - Parts Breakdown w/ Part Numbers (Caddy) 4
 - Caddy Part Numbers Chart 5
 - Parts Breakdown w/ Part numbers (Motor) 6
- Caddy Operation** 7
 - Operation 7
 - Pre-Heating the Caddy 8
 - Disposing the Oil 9
- The Electronics** 10
 - Motor Housing 10
 - Heating and Pump Lights 11
 - Electronics Troubleshooting 12
 - Wiring Diagrams 13
- The Motor and Pump** 14
 - Resetting the Motor 14
 - Troubleshooting the Motor 15
 - Replacing the Pump Head and/or Motor 16
 - Replacing the Motor and Pump Head 18
- Hardware** 19
 - Replacing the Heater Belt 19
- Troubleshooting** 21
 - Troubleshooting 21
 - Preventive maintenance 22
 - Wiring Diagrams (Enlarged) 23

General Information: Overview

The Grill Grease System works with any of Frontline International’s used oil systems to complete your Smart Oil Management program.

The Grill Grease System collects your grill grease throughout the day then pumps it into any of our used containment tanks. Solids are collected in an extra-large sediment basket. The safe silicone heater prevents congealing.



Construction/Features

- 100% stainless-steel construction
- Safe silicone heater to prevent congealing
- Swivel front and rear casters with brakes
- Extra-large sediment basket
- Power switch and break-away power cord
- Easy, quick-connect fittings
- 115-230 V 3.5 A 1/2HP motor
- Five-gallon-per-minute pump (19 liters)
- Easy to clean seamless construction
- UL, UL Sanitation listed
- One-year warranty on parts and labor

Benefits

- No manual handling of grill grease
- Simple system fits under grill drains
- Grill grease drains into top opening throughout the day
- Insurance and Workers’ Comp savings
- Less employee downtime
- Labor savings and greater employee safety
- Cleaner grounds and public image
- Avoid pollution fines

Installation and Operation Specifications

| | |
|--|---|
| Model | LS3-60-EU-GG Grill Grease Caddy |
| Power Requirements | 115-230 V 3.5 A, 50/60 Hz |
| Installation Space Requirements | 16.125 in. l x 17.188 in. w x 21.15 in. h (409.6 mm x 436.6 mm x 537.21 mm) |
| Shortening Capacity | 60 lb/8 Gal (27.2 kg/575 l) |
| Shipping Weight | 72 lb/130 lb on pallet (32.7 kg / 59 kg on pallet) |

Caddy Parts Breakdown

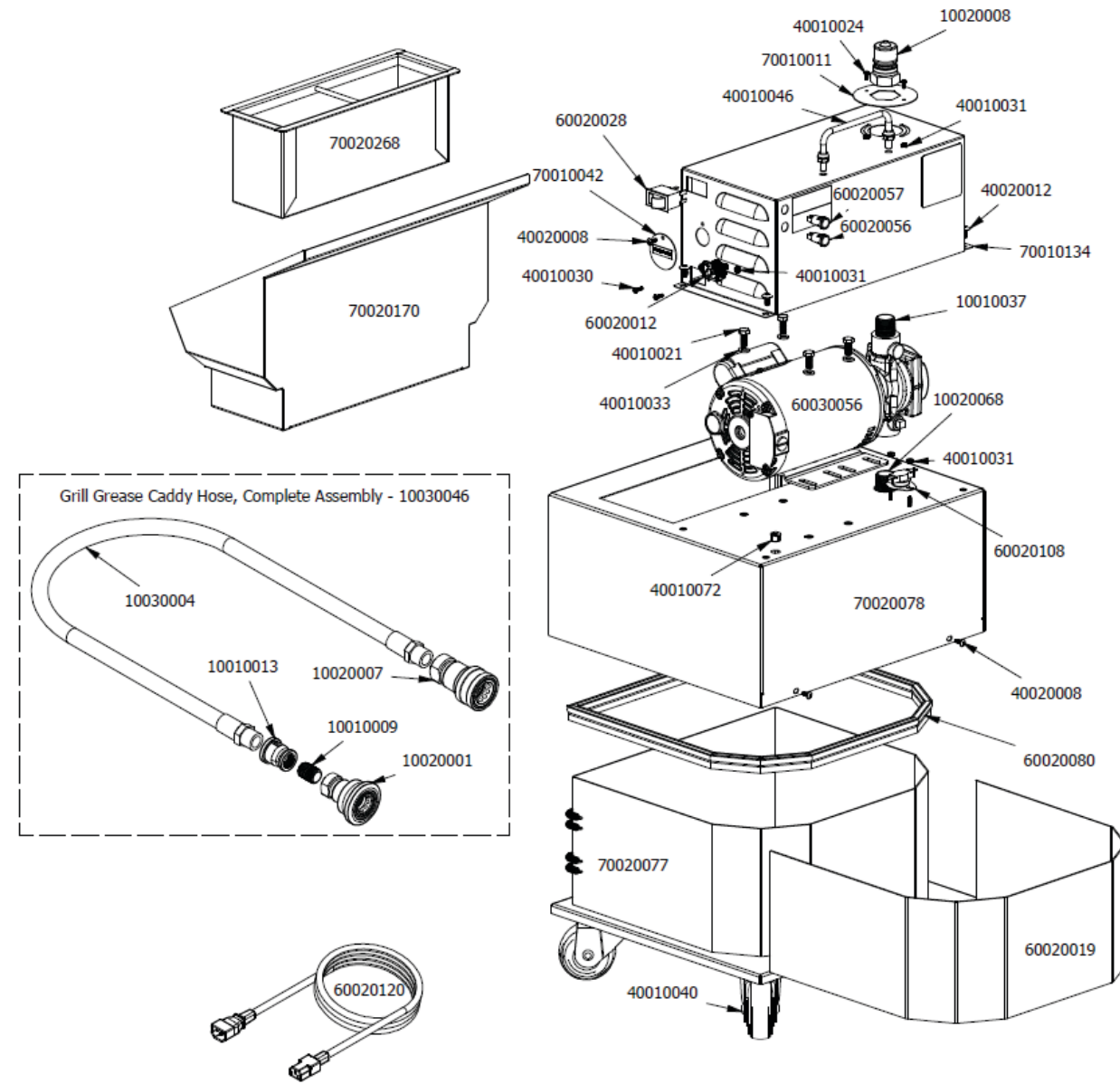

Caddy Part Numbers

| Part # | Description | Qty |
|----------|---|-----|
| 10010037 | 3/4" Galv. Close Nipple | 1 |
| 10020008 | 3/4" Quick Disconnect Fitting, Nipple, Food Grade | 1 |
| 10020068 | Grill Grease Caddy Suck Pipe | 1 |
| 10030046 | Grill Grease Caddy Hose Assembly | 1 |
| 10010009 | 1/2" Galv. Close Nipple | 1 |
| 10010013 | 3/4" to 1/2" Galv. Reducing Coupler | 1 |
| 10020001 | 1/2" Quick Disconnect Fitting, Coupler, Food Grade | 1 |
| 10020007 | 3/4" Quick Disconnect Fitting, Coupler, Food Grade | 1 |
| 10030004 | .750 White Kleenflow Hose, 48" L x 3/4" NPT | 1 |
| 40010021 | 5/16" - 18 x 3/4" Unslotted Hex Screw | 4 |
| 40010024 | 6-32 x 3/8" Panhead Screw | 2 |
| 40010030 | 6-32 x 1/2" Panhead Screw | 2 |
| 40010031 | 6-32 Hex Keps Nut | 6 |
| 40010033 | 5/16" Medium Split Lockwasher | 4 |
| 40010046 | Grill Grease Caddy Handle | 1 |
| 40010072 | 1/2" Split Locking Grommet | 1 |
| 40020008 | 10-24 x 1/2" Truss Head Screw | 5 |
| 40020012 | 1/4" - 20 Truss Head Screw | 4 |
| 60020012 | Panel Mount Receptacle for Molded Female Caddy Cord | 1 |
| 60020019 | 240V 250W Heater Belt | 1 |
| 60020028 | On/Off Rocker Switch | 1 |
| 60020056 | Amber Indicator Light 240V, 2W | 1 |
| 60020057 | Red Indicator Light 240V, 2W | 1 |
| 60020108 | 3/4" Disc Thermostat | 1 |
| 60020120 | Caddy Power Supply Cord, IEC for Control Panel | 1 |
| 60030056 | HR5 Motor & Pump | 1 |
| 70010011 | Grill Grease Disconnect Ring | 1 |
| 70010042 | Motor Reset Cover | 1 |
| 70010134 | LS-3-60GG Motor Cover | 1 |
| 70020077 | Grill Grease Caddy Rolling Chasis | 1 |
| 40010040 | 3" Swivel Caster, Poly Wheel | 4 |
| 60020080 | Edge Grip Gasket | 1 |
| 70020078 | LS-1-60GG Body Complete Assembly | 1 |
| 70020170 | Grill Grease Caddy Chute | 1 |
| 70020268 | LS-3-60GG Filter Basket | 1 |

Motor Parts Breakdown

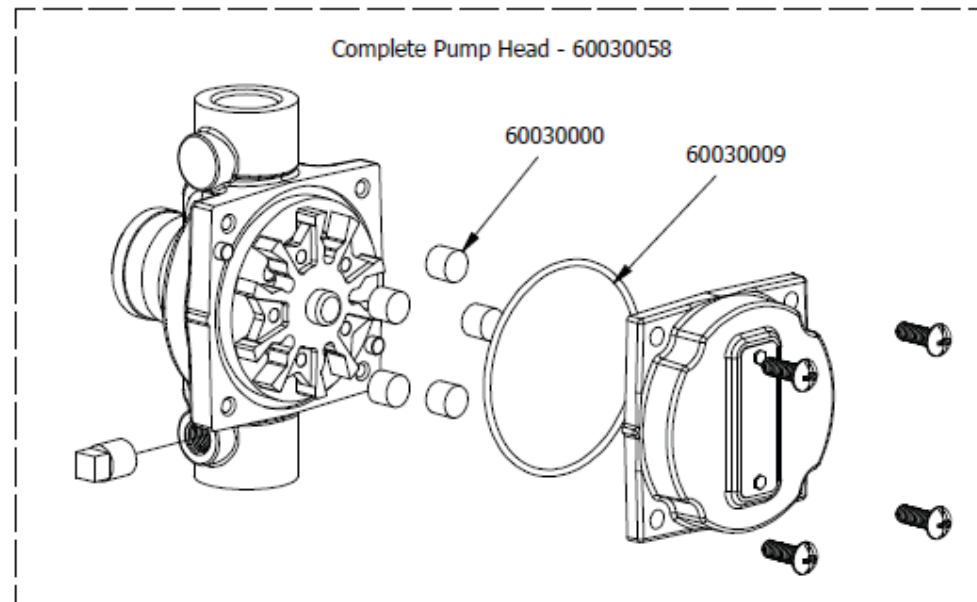
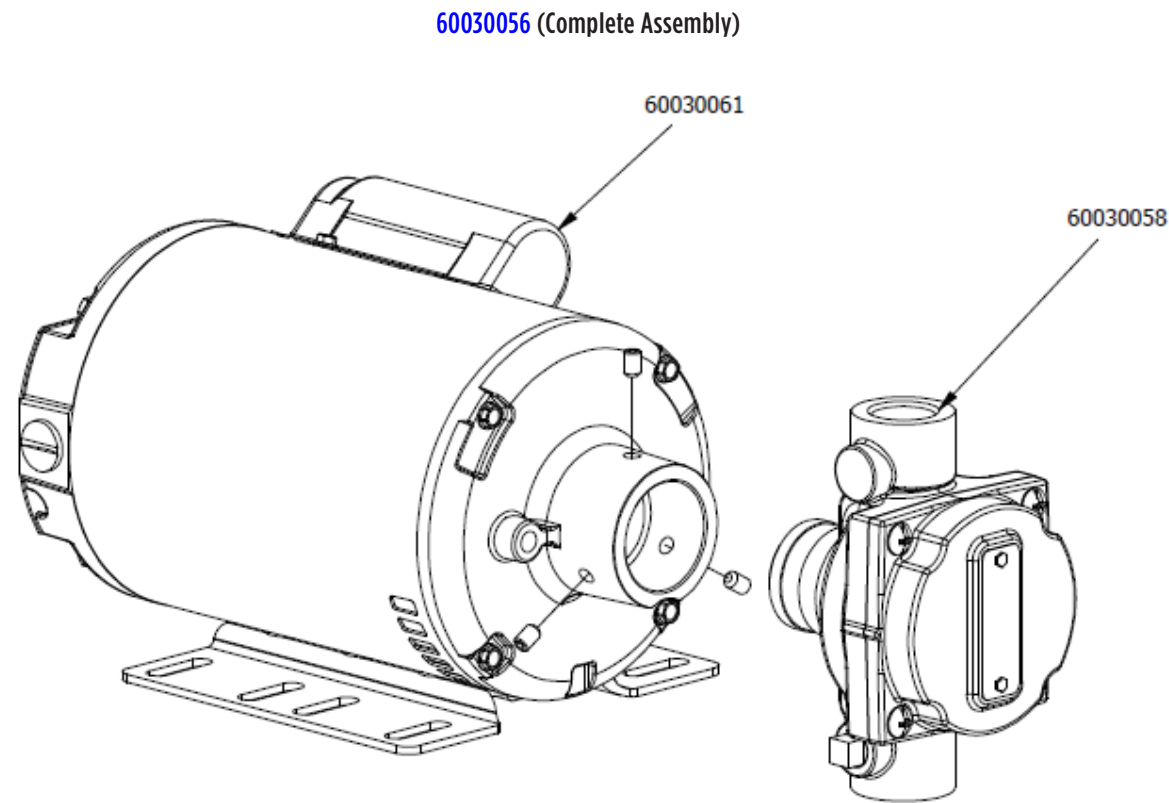

Caddy Operation: Operation

UNDERSTANDING THE SYSTEM

Using the caddy for your used oil has a few main processes. Its core uses are:

- 1) Removing used oil from fryers or traps
- 2) Heating up the used oil
- 3) Disposing the used oil

Pre-Heating the Caddy

- Heating the caddy is important to maintain the health and condition of the caddy.
- If the used oil is left in the caddy and cooled down it can potentially lead to clogs and damage to the unit.
- Make sure to pre-heat the caddy or immediately dispose of the used oil.

Disposing the Used Oil

- Disposing of used oil is the main purpose of the caddy this allows you to transport and store in a proper, contained enclosure for the removal of used oil from your location.
- Following the guidelines for proper operation of the caddy will improve workflow and productivity of your business.



Pre-Heating the Caddy

Powering the Caddy

When connecting the caddy up to the tank to heat the unit:

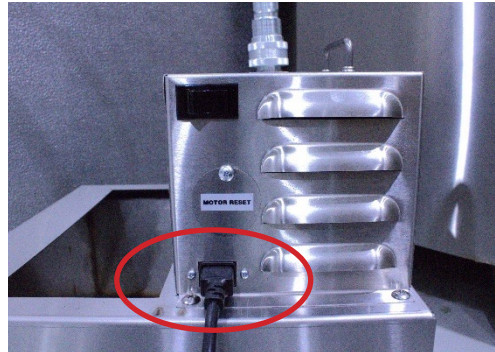

Step 1: Connect the power cord to the plug on the electrical housing of the caddy.



Step 2: Connect the power cord to the front of the control panel.

Control Panel Operation

To start the Pre-Heat process, touch anywhere on the screen with the tank percentage displayed.



Step 1: Push the “Pre-Heat Caddy” button on the control panel.



Step 2: The heating progress bar will show up on the bottom of the screen.



Step 3: After the heating process time has passed, a message will appear on the control panel display.

Step 4: Proceed with the oil disposing process...

Disposing the Oil

Connecting the Caddy to the Tank

When connecting the caddy to the tank to dispose of the oil:



Step 1: Connect the caddy hose to the top of the caddy outlet. Then connect the hose to the tank inlet.



Step 2: Connect quick disconnect to top of motor housing.

Control Panel Operation

To start the disposing process, touch anywhere on the screen with the tank percentage displayed.



Step 1: Push and hold down the Dispose button.



Step 2: Once all oil is drained from caddy, you can release the button.

Electronics: Motor Housing

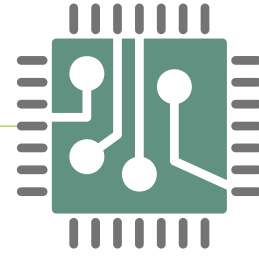

Rocker Switch

The rocker switch is used for toggling the power on and off the unit.

Motor Reset Plate

This plate covers the motor reset button. Move plate to the side for access to the switch.

Power Cord Inlet

This plug inlet is for the male end of the power cord, used for both the power cord to wall and the power cord to tank.

Pump Power Light

The pump power light will illuminate when the temperature reaches 120° F/49° C.

Heater Power Light

The heater light will illuminate when the unit is powered and heating up.

Heating and Pump Lights

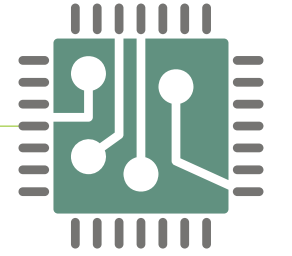

Pump Power Light (Green light)

The pump power light will light up when the caddy is heated around 120° F/49° C.
It normally takes around 20-30 minutes for this light to illuminate.

Heater Power Light (Amber light)

When the caddy is plugged into a power source, the amber heater power light will light up.
This light lets you know the heater is on and warming up.

Troubleshooting

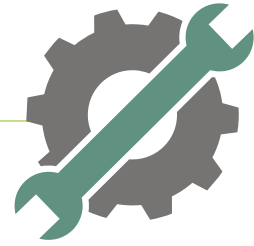

| Issues | Troubleshooting Steps | Components | Resolutions |
|---------------------------|--|------------------------|---|
| On/off switch not working | <ul style="list-style-type: none"> • Check for power to the unit • Test voltage • Check power cords | On/off switch | <ul style="list-style-type: none"> • Check if switch toggles to both sides • Check connection of terminals • Check condition of harness |
| | | Wiring | <ul style="list-style-type: none"> • Check connection of terminals • Check condition of harness |
| | | Power cords/receptacle | <ul style="list-style-type: none"> • Check if power cords are connected • Check condition of cords • Check power at control panel outlet |
| Breaker tripping | <ul style="list-style-type: none"> • Check for shorts and clogs in the lines | Harness | <ul style="list-style-type: none"> • Check for shorts in the different components of the electrical system |
| | | Hose/suck pipe | <ul style="list-style-type: none"> • Check for clogs in the hose and suck pipe |
| | | Pump head | <ul style="list-style-type: none"> • Check that the rollers are not damaged or missing |
| | | Electronic housing | <ul style="list-style-type: none"> • Check for shorts in the rocker switch or power port |

Wiring Diagrams

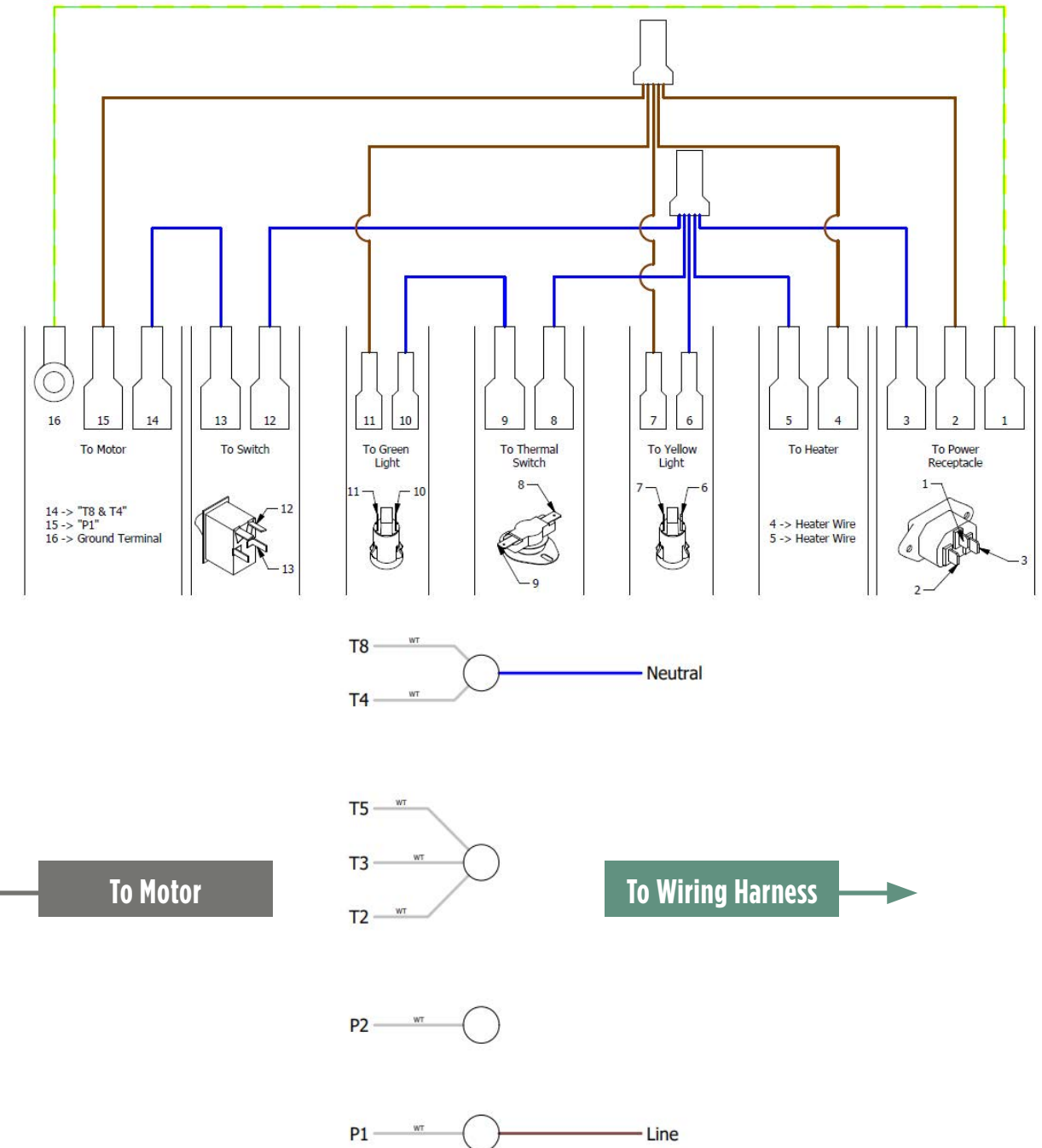
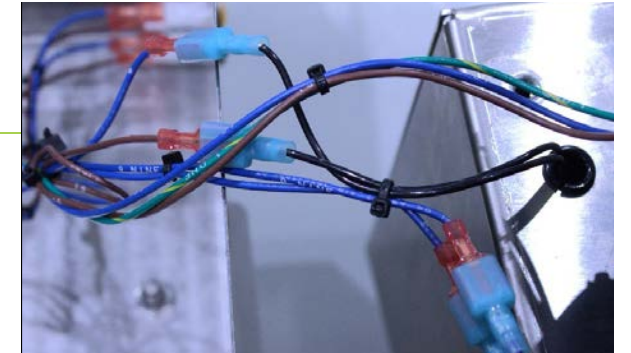

The Motor & Pump: Resetting the Motor



Motor Reset

Provide power to the caddy using the wall-to-caddy power cord or the tank power cord.

Using the tank power cord: Press and hold the Dispose button on the control panel of the tank while pressing hard on the reset switch.

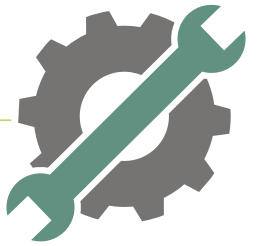

Fig 1-A



Fig 1-B

Troubleshooting the Motor



Unit Not Pumping

Proper cleaning and maintenance can extend the life of the motor and pump. If the motor is powered but not pumping, there are a few things to check.

Motor Freezing Up (Fig 3-A)

If the motor is freezing up, loosen the four screws on the pump head a quarter turn.



Fig 3-A

Rollers (Fig 3-B)

The pump head itself and the five rollers inside can cause the unit to not function properly.

Inspecting the rollers:

- The rollers should be able to freely move within the pump head slots.
- Check for any obstructions, fragments or broken pieces.

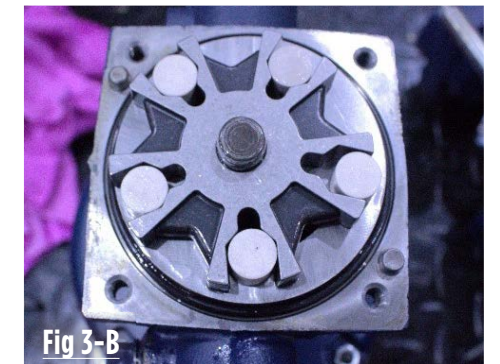

Fig 3-B

Clogs

Clogs are another potential cause of a motor not pumping. The three areas of the motor and pump that can be affected by a clog are the suck pipe, caddy hose, and the pump head.

To check the pump head for clogs:

- Remove the four screws in the housing and look for any obstructions within the gear and rollers.

To check the hose and suck pipe:

- Detach the hose and suck pipe from the motor.
- Run warm water through them, which can clear most obstructions.

Hose Quick Disconnect Fittings

Verify the fittings on both ends of the hose are properly connected.

Replacing the Pump Head and/or Motor

Changing the Pump Head

Tools needed:  Screwdriver, Pipe Wrench, Needle-Nose Pliers, One-Inch Wrench, Allen Wrench.



Step 1: Remove Grill Grease Caddy chute and basket and set to the right of the Caddy.



Step 2: Remove the four screws in the motor cover housing.



Step 3: Remove motor housing, pivot and rest the housing onto the caddy chute in order to take pressure off the wire casing.



Step 4: Disconnect the quick disconnect from the top of the pump.



Step 5: Remove screws to open wire housing.

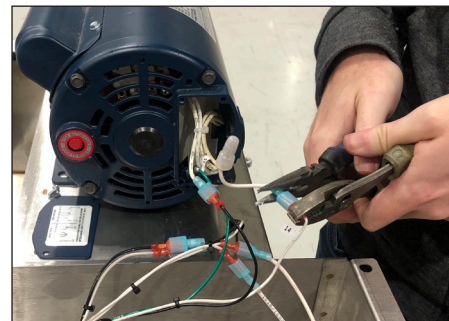

Step 6: Disconnect the wire harness by separating the wire disconnect terminals.

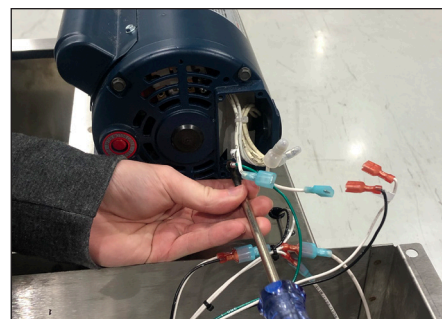

Step 7: Loosen the ground wire screw.



Step 8: Remove the four bolts that attach the motor to the caddy frame.



Step 9: Lift to remove motor. Turn motor 90° and set on the Caddy frame.

Replacing the Pump Head and/or Motor (continued)

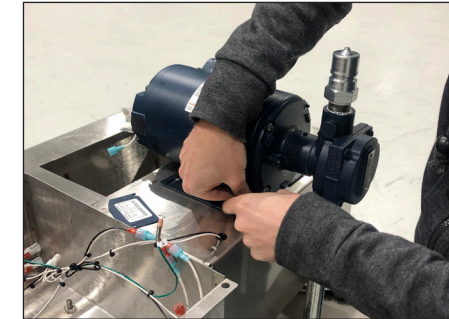

Step 10: Reinsert one bolt to create a stable work surface.

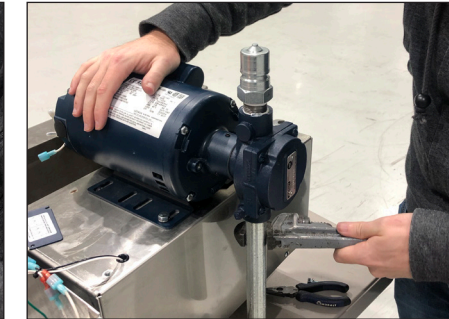

Step 11: Using a pipe wrench, remove the suck pipe from the bottom of the pump.



Step 12: Using an Allen wrench, loosen (don't remove) the three pins holding the pump head to the motor.



Step 13: You are now able to swap in the new Pump Head, replacing the old.

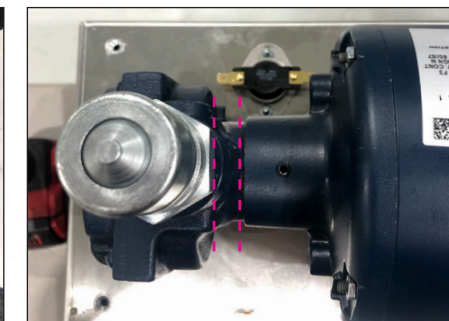

Step 14: Begin re-assembly by reattaching the suck pipe and quick disconnect nipple.

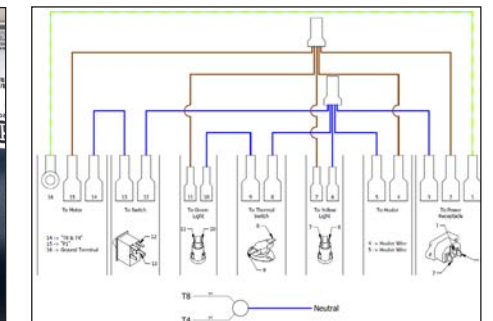

Step 15: Rewire the new motor in the same configuration as the wiring diagram shown in this manual (page 13).

Note: When tightening the nipple on to the pump, align a flat side of the nipple parallel to the motor to make it easier to put the motor housing back on.



Step 16: Using the four bolts, reattach the motor to the caddy frame.



Step 17: Connect the wires back to the wiring harness terminals.



Step 18: Resecure the motor housing back to the caddy using the four screws. ■

Replacing the Motor and Pump Head

Changing the Pump Head

Tools needed:  Screwdriver, Pipe Wrench, Needle-Nose Pliers, One-Inch Wrench, Allen Wrench.

To begin, follow steps 1 - 8 from page 16, Replacing the Pump Head and/or Motor instructions.

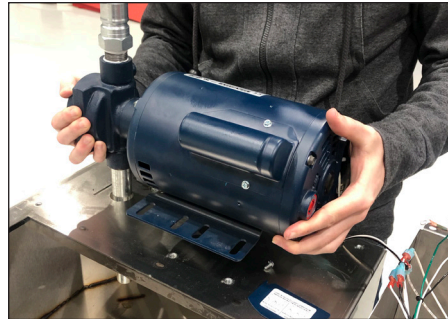

Step 9: Lift to remove motor. Turn motor 90° and set on the Caddy frame.



Step 10: Reinsert one bolt to create a stable work surface.

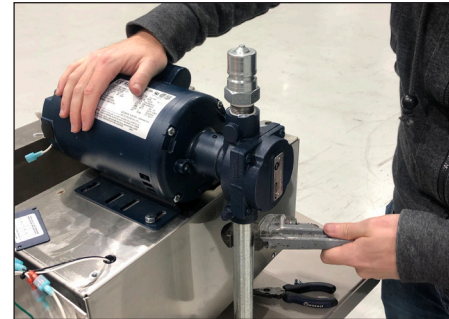

Step 11: Using a pipe wrench, remove the suck pipe from the bottom of the pump.



Step 12: You are now able to swap the new Motor and Pump Head assembly for old Motor and Pump.

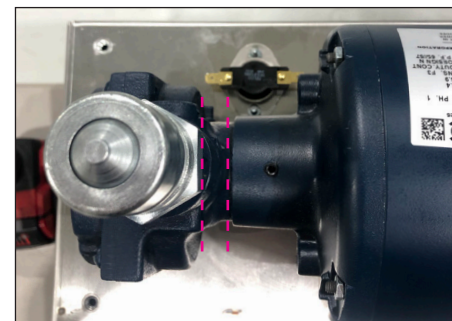

Step 13: Begin re-assembly by reattaching the suck pipe and quick disconnect nipple.

Note: When tightening the nipple on to the pump, align a flat side of the nipple parallel to the motor to make it easier to put the motor housing back on.

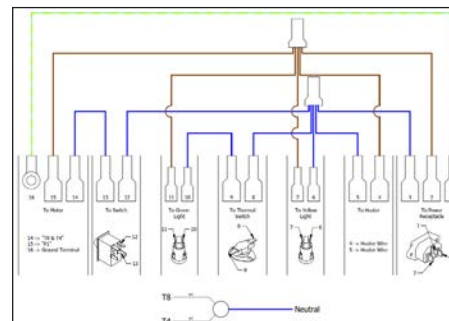

Step 15: Rewire the new motor in the same configuration as the wiring diagram shown in this manual (page 13).



Step 16: Using the four bolts, reattach the motor to the caddy frame.

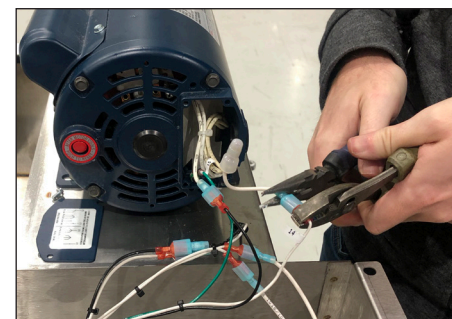

Step 17: Connect the wires back to the wiring harness terminals.



Step 18: Resecure the motor housing back to the caddy using the four screws. ■

Hardware: Replacing the Heater Belt

Changing the Heater Belt

Tools needed:  Screwdriver, Pipe Wrench, Needle-Nose Pliers, One-Inch Wrench, Allen Wrench, Heavy-Duty/Duct Tape (optional)

To begin, follow steps 1 - 9 from page 16, Replacing the Pump Head and/or Motor instructions.



Step 10: Remove screws at the base of the caddy bucket.



Step 11: Lift the bucket cover...



Step 12: ... and rest it on the Caddy body.



Step 13: Cut the heater belt wires and pull the wires back through the Caddy body.



Step 14: Carefully remove the tape from the back of the bucket. If tape tears you will need to replace with heavy duty tape or duct tape when re-assembling.

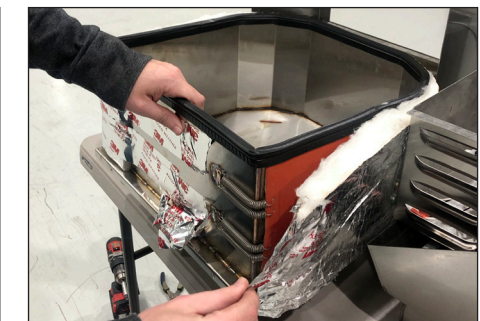

Step 15: Remove insulation to expose springs, setting insulation to the side.

Warning: When handling insulation, it is recommended that single-use or other safety gloves be worn. 



Step 16: Remove rubber seal from top of Caddy bucket assembly. Start at the middle of the flat front side.



Step 17: Using pliers, unclip the springs, four on each side of the belt.



Step 18: Discard old belt assembly.

(continued)

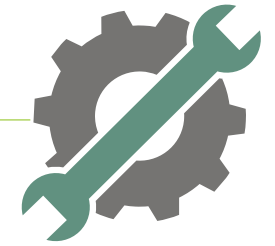

Troubleshooting

Hardware: Replacing the Heater Belt (continued)

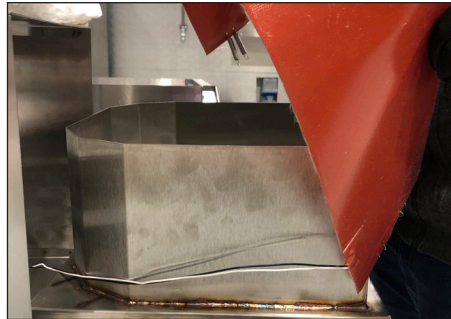

Step 19: Put the NEW heater belt in place, being careful to keep belt wires around the bottom of the CURVED assembly.



Step 20: Attach the springs.



Step 21: Once springs are re-attached, re-secure the rubber gasket, starting at the mid-point of the FLAT backside of the Caddy assembly.



Step 22: Wrap the insulation back around the new belt. Secure with tape.

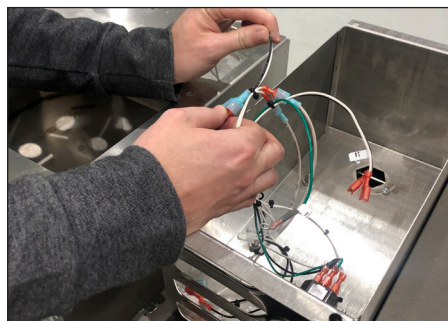

Step 23: Run the heater wires back through housing. Do NOT reconnect wires at the step.



Step 24: Attach the body back to the bucket with the four screws.

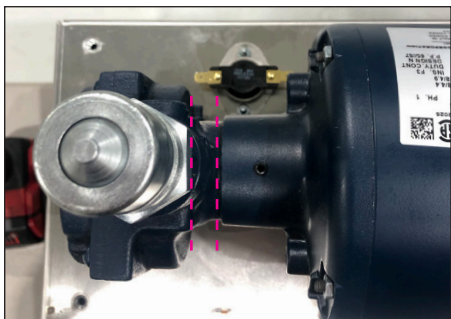

Step 25: Reattach the quick disconnect nipple.

Note: When tightening the nipple on to the pump, align a flat side of the nipple parallel to the motor to make it easier to put the motor housing back on.

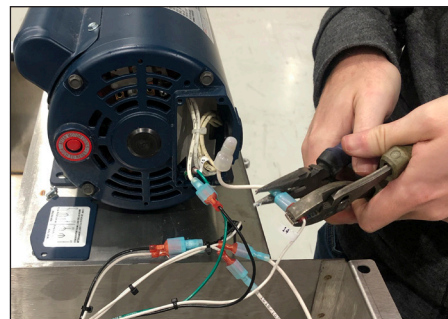

Step 26: Re-connect the Heater Belt wires back to the wiring harness, either by splicing or using new wire terminals.



Step 27: Using the four bolts, reattach the motor to the caddy frame. ■

| Issues | Troubleshooting Steps | Components | Repair Steps | Resolutions |
|-------------------|--|------------------------|---|--|
| Motor not pumping | <ul style="list-style-type: none"> • Check for power to the unit • Test voltage • Check power cords | On/off switch | <ul style="list-style-type: none"> • Check if switch toggles to both sides • Check connection of terminals • Check condition of harness | Replace switch. |
| | | Wiring | <ul style="list-style-type: none"> • Check connection of terminals • Check condition of harness | Replace harness. |
| | | Power cords/receptacle | <ul style="list-style-type: none"> • Check if power cords are connected • Check condition of cords • Check power at control panel outlet | Replace power cord. Replace receptacle. |
| | <ul style="list-style-type: none"> • Check for clogs in hose, connectors, and suck pipe | Hose | Disconnect hose from caddy, run warm water through hose. | Replace hose. Clean hose. |
| | | Suck pipe | Lift motor out of unit, detach suck pipe, and run warm water through pipe. | Clean pipe. |
| | | Quick disconnects | Detach the quick disconnects from the hose. Clear any blockage in the connectors. | Replace connectors. Clean connectors. |
| Breaker tripping | <ul style="list-style-type: none"> • Check for shorts and clogs in the lines | Harness | <ul style="list-style-type: none"> • Check for shorts in the different components of the electrical system | Replace shorted part or wires. |
| | | Hose/suck pipe | <ul style="list-style-type: none"> • Check for clogs in the hose and suck pipe | Clean parts or replace. |
| | | Pump head | <ul style="list-style-type: none"> • Check that the rollers are not damaged or missing | Replace needed. |
| | | Electronic housing | <ul style="list-style-type: none"> • Check for shorts in the rocker switch or power port | Replace shorting parts. |

Preventative Maintenance

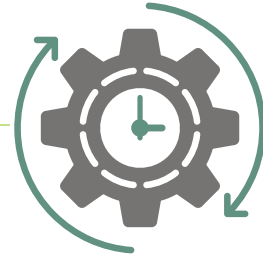

| Component | Task | Frequency |
|---------------|---|------------------|
| Suction hose | <ul style="list-style-type: none"> • Clean the inside of the suction hose with hot water and a degreaser. • Verify suction hose shows no sign of damage and quick disconnects are tightly secured to the hose. | Every six months |
| Power cord | <ul style="list-style-type: none"> • Verify power cord shows no wear and all conductors are contained within the insulation. • If power cord is damaged, contact service for replacement. <p><i>Note: The unit cannot be operated until the power cord is replaced.</i></p> | Every six months |
| On/off switch | <ul style="list-style-type: none"> • Verify switch is tightly secured to unit and operates as intended. | Every six months |

Wiring Diagrams

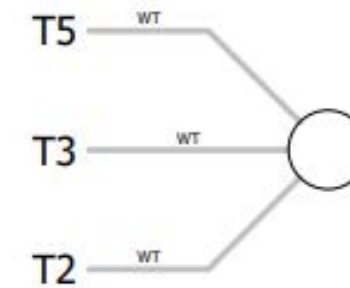
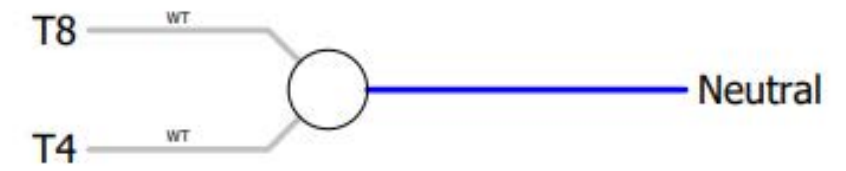

FRONTLINE[™]
i n t e r n a t i o n a l

Frontline International Inc. • 187 Ascot Parkway, Cuyahoga Falls, OH 44223
Phone: 330-861-1100 • Fax: 330-861-1105 • www.frontlineii.com