

## Operation and Servicing Manual

# Waste Oil Caddy



**DANGER:** Please read this operation and servicing manual thoroughly before installing, servicing or using this equipment. Failure to properly install, service or use this equipment, or alteration of this equipment, can cause serious property damage, injury or death.

### Models

- 10SS-NA – Transport Caddy (10Gal/37.8 l)
- 10SS-NA-LP – Low Profile Transport Caddy (8Gal/30.28 l)
- 16SS-NA – Transport Caddy (16Gal/60.5 l)
- 20SS-NA – Transport Caddy (20Gal/ 75.7 l)
- 16SS-NA-W5 – Transport Caddy with 5" (12.7 cm) Castors (16Gal/60.5 l)
- 20SS-NA-W5 – Transport Caddy with 5" (12.7 cm) Castors (20Gal/75.7 l)

# About this manual

Store this manual in a safe place for future reference.

### About Frontline International, Inc.

- Through a dedication to the development, manufacture, and delivery of quality cooking oil management systems, Frontline International, Inc. remains a leading global source for equipment solutions that safely and efficiently dispense, contain, monitor, extract, transport, or filter cooking oil for immediate on-premise recycling and use.
- A stakeholder focused organization, our sustainability relies on initiatives that benefit associates, customers and community – from responsible manufacturing techniques to conservation of resources and performance metrics.
- With our valued network of service and installation experts our branded and custom products enhance productivity, improve operations and save costs for professionals within foodservice, hospitality, and other markets around the world, every day.

### About our Waste Oil Caddy models

Frontline offers several different caddy models and upgrades to meet your needs.

### Table of contents

---

Parts View.....	1
Operation .....	2
Troubleshooting.....	5
Cautions and notes .....	6
Caddy options.....	6
Warranty .....	7

# Record your model and serial numbers

Find the model and serial numbers between the caddy handle at the rear of the motor. Record the numbers in the following space for warranty and parts information.

Model Number: \_\_\_\_\_

Serial Number: \_\_\_\_\_

## Parts View

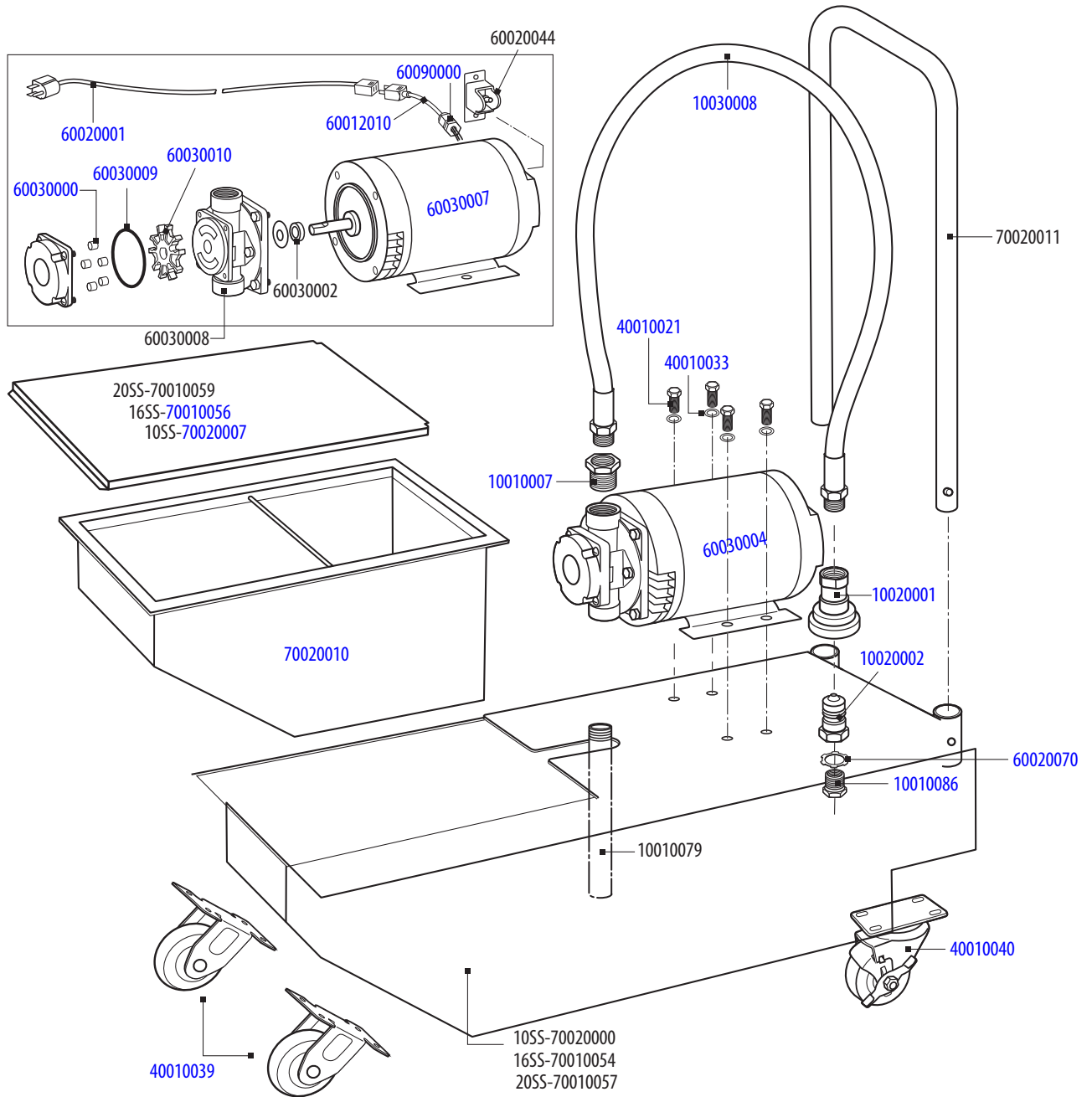

### Caddy Part Numbers and Part Descriptions

<b>70020000</b>	10SS Caddy Body	<b>60030004</b>	1/2 HP Caddy Motor and Pump	<b>60030000</b>	Pump Rollers - White Teflon Rollers (Set of 5)
<b>70020007</b>	10SS Caddy Lid	<b>10010079</b>	3/4" x 1/2" Galvanized Nipple	<b>60030009</b>	Silicone O Ring for Caddy Pump
<b>70010054</b>	16SS Caddy Body	<b>10010007</b>	3/4" x 1/2" Galvanized Reducing Hex Brushing	<b>60030010</b>	Pump Rotor Gear for Caddy Pump
<b>70010056</b>	16SS Caddy Lid	<b>10030008</b>	.500 White Kleenflow Hose 48" L	<b>60030008</b>	Pump Head for 1/2 HP for Caddy Motor
<b>70010057</b>	20SS Caddy Body		1/2" NPT Swivel one end, 1/2" NPT Rigid one end	<b>60030002</b>	Seal Kit for Caddy Pump
<b>70010059</b>	20SS Caddy Lid	<b>10020001</b>	1/2" Quick Disconnect Coupler - Nickel Plated	<b>60030007</b>	1/2 HP Caddy Motor only w/Power Cord & Switch
<b>70020010</b>	Caddy Basket	<b>10020002</b>	1/2" Quick Disconnect Nipple- Nickel Plated	<b>60020044</b>	Caddy Motor Switch Kit
<b>40010039</b>	3" Rigid Poly Caster	<b>60020070</b>	1/2" locknut	<b>60090000</b>	1/2" NPT Domed Cord Strain Relief
<b>40010040</b>	3" Poly Swivel Castor w/ Top Locking Brake	<b>10010086</b>	1/2" x 3/8" Galvanized Reducing Hex Brushing	<b>60012010</b>	10" Power Cord
<b>70020011</b>	Caddy Handle	<b>40010021</b>	5/16" - 18 x 3/4" Unslotted Hex Screw	<b>60020001</b>	Caddy Power Supply Cord
		<b>40010033</b>	5/16" Medium Split Lockwasher 18-8 SS		



**DANGER:** This filtering unit is intended for use with oil at temperatures between 100° F (38° C) and 375° F (190° C). Always wear protective, heat-resistant gloves, heat-resistant apron and goggles when using this equipment. Failure to properly use this equipment can lead to serious injury or death.

## Operation

Follow these steps when working with your caddy.

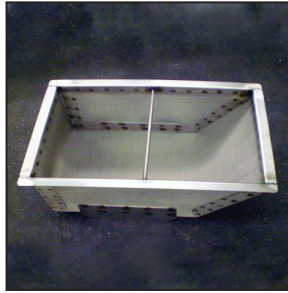

1. Complete all operations with the proper safety gear that includes eye goggles, hot oil gloves, and a hot oil apron.
2. Make sure the filter basket is in place before oil is drained into the caddy.



**Never drain oil into the caddy without the filter basket in place as this will cause serious damage to the pump.**



3. Open the lid on the caddy and position it under the fryer.
4. Drain the used cooking oil into the caddy being careful of hot oil. Grill grease or chicken drippings may be disposed if placed in the filter basket and mixed with hot oil.
5. Note that the temperature should be at least 100F (38C) but not higher than 375F (190C).
6. Secure the caddy lid with the safety latch before moving the caddy.

7. Carefully pull/push the caddy slowly to the used oil storage tank or remote fill station.
8. Check the storage tank and make sure the green light is lit on the panel. If the green light is not ON, the system has lost power (See Troubleshooting).
9. Connect the hose from the caddy to the storage tank or fill station by connecting the large female fitting on the caddy hose to the male fitting on the tank. With the outer ring pulled back, push the female fitting onto the male fitting on the tank or fill station.



**Fill Station**

10. Gently pull on the caddy hose to ensure a proper connection has been made.

**IMPORTANT – The caddy pump could be damaged if this is not properly connected.**



11. Plug the electrical cord from the caddy motor into the receptacle located on the storage tank control panel.

**IMPORTANT – Use of any receptacle other than the one in the control panel could result in a tank overflow.**



**DANGER: The caddy lid is designed to prevent hot oil spills when transporting the caddy. Failure to use the lid or properly secure the lid may result in hot oil spills, which can lead to serious injury or death.**



12. The caddy motor switch is located on the rear of the motor, and will need to be in the "ON" position.

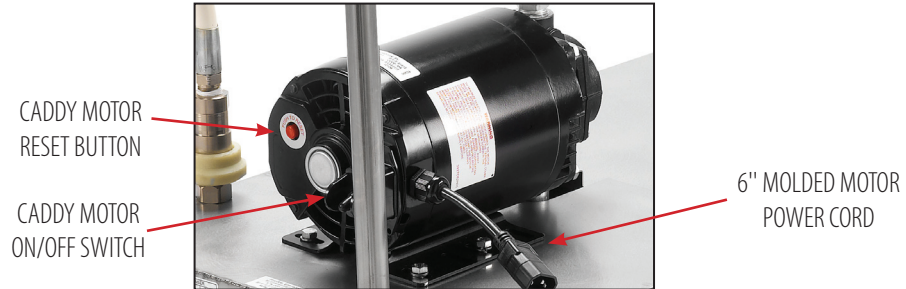

13. Push in and HOLD the black button on the control panel labeled "PUSH TO PUMP".

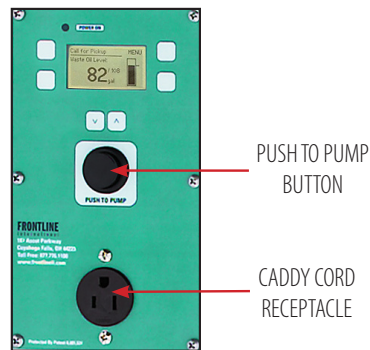

14. When the caddy is empty of waste shortening, continue to hold the button and run the pump for an additional 30 seconds. When finished, release the black button on the control panel face. Note that the pump will make a different sound when the caddy is empty.

15. Use gloves to disconnect the hose from the tank and place the female fitting onto the male fitting on top of the caddy.



**IMPORTANT – The hose will be HOT. Use gloves!**

16. Push the black button on the control panel again to drain any oil left in the hose back into the caddy.

17. Disconnect the power cord from the tank control panel and secure the power cord to the caddy.

18. Clean the filter basket with hot soapy water or degreaser.

19. Dry and replace filter basket back inside the caddy.

20. Clean the outside of the caddy with stainless cleaner.

## Troubleshooting

See the following table to troubleshoot problems

PROBLEM	PROBABLE CAUSE	CORRECTIVE ACTION
Caddy motor will not run.	The caddy motor is not turned ON.	Turn the motor ON with the switch located on the back of the motor.
	Caddy motor reset switch has tripped.	Press the motor reset switch on the back of the caddy motor.
	The caddy power cord is not making proper connection.	Ensure the caddy power cord is completely plugged into the motor and the control panel receptacle .
	The tank or control panel at the fill station has lost power.	
Ensure the outlet that the tank or fill station control panel is plugged into has not lost power. If there is no power to the outlet make sure the circuit breaker has not tripped or that the outlet is not on a switch that has been turned off.		
Caddy motor runs but no oil will pump.	Disconnect fittings are not properly connected.	Make sure the female disconnect fitting is properly connected to the male fitting.
	Caddy hose may be plugged with grease.	Run the caddy hose under hot water to liquefy any grease that may be clogging the hose.
	Caddy pump may be plugged with grease.	Remove the four screws on the front of the pump and clean the inlet and outlet port of the pump, and the rotor gear.
		Make sure that nothing is blocking the inlet tube that goes down into the oil.
		Assure that the oil being discarded is in liquid state.
<b>Call 330-861-1100 if you have checked all of the above and the problem still has not been resolved.</b>		

## Cautions and notes

Follow these cautions and notes.

1. Always keep the screen in place when draining oil into the cart. Draining oil into the caddy without the filter basket in place will cause serious damage to the pump and storage tank. This will void the warranty on the equipment.
2. Never attempt to pump solid or cold grease – this will clog the pump. Make sure oil is warm and liquid before pumping.
3. Do not attempt to pump oil if green light on the control panel is not lit.
4. Grill grease or chicken drippings maybe pumped if placed in filter basket and mixed with hot oil. Failure to mix with hot oil will clog pump and filter basket and could damage both.

## Caddy options

You can update all caddy models with the following filters:

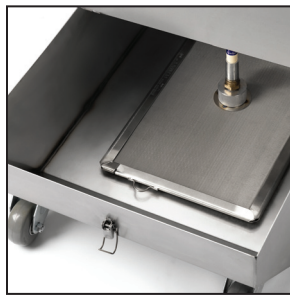

**Stainless Steel**

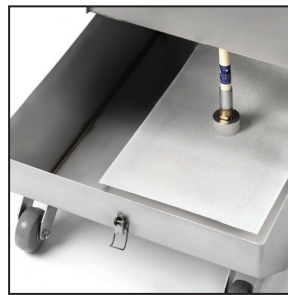

**Paper**

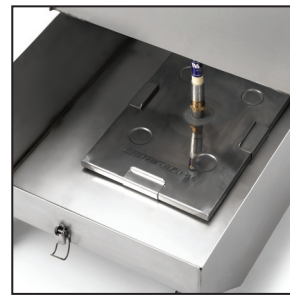

**Carbon Fiber**

If you have one of these filter update kits, see the attached instructions.

---

## Warranty

### Limited Warranty for Frontline International, Inc. Appliances

Subject to the following conditions, Frontline International Inc. makes the following limited warranties to the original purchaser only for Frontline International appliances and replacement parts:

**NEW EQUIPMENT:** Any non-user part of a new appliance, except lamps, which proves to be defective in material or workmanship within one (1) year from date of original shipment, will be repaired or replaced without charge F.O.B. factory, Cuyahoga Falls, Ohio, or F.O.B. authorized distributor. Non-user parts on systems specifically include heater, level switch, and the control panel. Motors, pumps, and customer abuse will not be covered by this warranty.

**REPLACEMENT PARTS:** Any appliance part, except lamps, which proves to be defective in material or workmanship within ninety (90) days from the date of original installation, will be repaired or replaced without charge F.O.B. factory, Cuyahoga Falls, Ohio or F.O.B. authorized distributor.

This warranty for new equipment parts covers the repair or replacement of the defective part, and any labor charges for the removal and installation of any non-user part specified above. Replacement parts do not have any labor coverage.

Any claim must be represented to either Frontline International or the distributor from whom the appliance was purchased. No allowance will be granted for repairs made by anyone else without Frontline International's written consent. If damage occurs during shipping, notify the sender at once so that a claim can be filed.

THE ABOVE LIMITED WARRANTY SETS FORTH THE SOLE REMEDY AGAINST FRONTLINE INTERNATIONAL FOR ANY BREACH OF WARRANTY OR OTHER TERM. BUYER AGREES THAT NO OTHER REMEDY (INCLUDING CLAIMS FOR ANY INCIDENTAL OR CONSEQUENTIAL DAMAGES) SHALL BE AVAILABLE.

The above warranty does not apply (a) to damage resulting from accident, alteration, misuse, or abuse; (b) to cold oil in storage tank due to main power being removed or unplugged from a system; (c) if the equipments serial number is removed or defaced; or (d) for lamps.

THE ABOVE LIMITED WARRANTY IS EXPRESSLY IN LIEU OF ALL OTHER WARRANTIES, EXPRESSED OR IMPLIED, INCLUDING MERCHANTABILITY AND FITNESS, AND ALL OTHER WARRANTIES ARE EXCLUDED. FRONTLINE INTERNATIONAL NEITHER ASSUMES NOR AUTHORIZES ANY PERSON TO ASSUME FOR IT ANY OTHER OBLIGATION OR LIABILITY.

---

