

# SERVICE MANUAL

## FRI-JADO FJ7500 7-SPIT ROTISSERIE OVEN

### MODELS

FJ7500\*



\*Fri-Jado produced Programmable Rotisseries with serialnumbers starting with 7500

#### - NOTICE -

This manual is prepared for the use of trained Service Technicians and should not be used by those not properly qualified. If you have attended a training for this product, you may be qualified to perform all the procedures in this manual.

This manual is not intended to be all encompassing. If you have not attended a training for this product, you should read, in its entirety, the repair procedure you wish to perform to determine if you have the necessary tools, instruments and skills required to perform the procedure. Procedures for which you do not have the necessary tools, instruments and skills should be performed by a trained technician.

Reproduction or other use of this Manual, without the express written consent of Fri-Jado, is prohibited.



EMPTY PAGE

## INDEX

<b>Index</b> .....	<b>3</b>
<b>General technical data</b> .....	<b>4</b>
Technical Data .....	4
<b>Programming instructions</b> .....	<b>5</b>
<b>Optional settings</b> .....	<b>7</b>
<b>Removal and replacement of parts</b> .....	<b>9</b>
Right or left side panel.....	9
Top cover.....	9
Knob.....	9
Instrument panel .....	10
Electric panel.....	10
Display.....	11
Panel and keypad assembly .....	11
Namepanel.....	11
Quartz lamp.....	12
Power section.....	12
High limit thermostat.....	13
Thermostat.....	13
Rotor or main switch .....	14
Contactor .....	15
Blower motor.....	15
Blower motor bottom rotisserie (Stacked Models) .....	16
PT500 sensor .....	16
Heating element.....	17
Drive motor.....	17
Door adjustment (left side).....	18
Door glass inside.....	18
Door glass outside .....	19
<b>Electrical tests and service procedures</b> .....	<b>20</b>
PT500 Sensor test.....	20
Heating element test.....	20
Keypad test .....	21
Control location.....	22
<b>Part 1: General troubleshooting list</b> .....	<b>23</b>
Troubleshooting .....	23
<b>Part 2: Analytic troubleshooting list</b> .....	<b>24</b>
Servicing and repairing .....	24
<b>Exploded views &amp; Partlists</b> .....	<b>28</b>
FJ7500 - Sheet Iron Work .....	28
FJ7500 - Components .....	30
<b>Electrical diagrams</b> .....	<b>32</b>
FJ7500 - Circuit diagram.....	32
FJ7500 - Wiring diagram .....	33

## GENERAL TECHNICAL DATA

This manual covers the Fri-Jado produced Programmable Rotisseries with seven spits (28 to 35 chickens) starting with serialnumber #7500 (called FJ7500 from here). Ovens will also be delivered in stacked versions.

All of the information, illustrations and specifications contained in this manual are based on the latest product information available at the time of printing.

### TECHNICAL DATA

Type	<b>FJ7500</b>
Power	9500W
Fuses needed with power connection 208 V, 3 ~ 60 Hz (3 phases without zero)	3x 35 A
Fuses needed with power connection 208 V, 1N ~ 60 Hz (1 phase with zero)	-
Recommended plug	NEMA 15-50P 
<i>Stacked cabinets: each cabinet comes with separate power cord!!</i>	
Net weight	399 lbs.
Gross weight	478 lbs.
Height	40"
Width	38 13/16"
Depth	33 1/2"

#### Tools

- Standard set of tools.
- Metric wrenches, sockets and hex socket key wrenches.
- VOM with AC current tester (any VOM with a sensitivity of at least 20,000 ohms per volt can be used).
- Insulation value tester (Megger).
- Temperature tester.
- TL 84919 Field Service Grounding Kit.

PROGRAMMING INSTRUCTIONS

**DISPLAY AND KEYS**

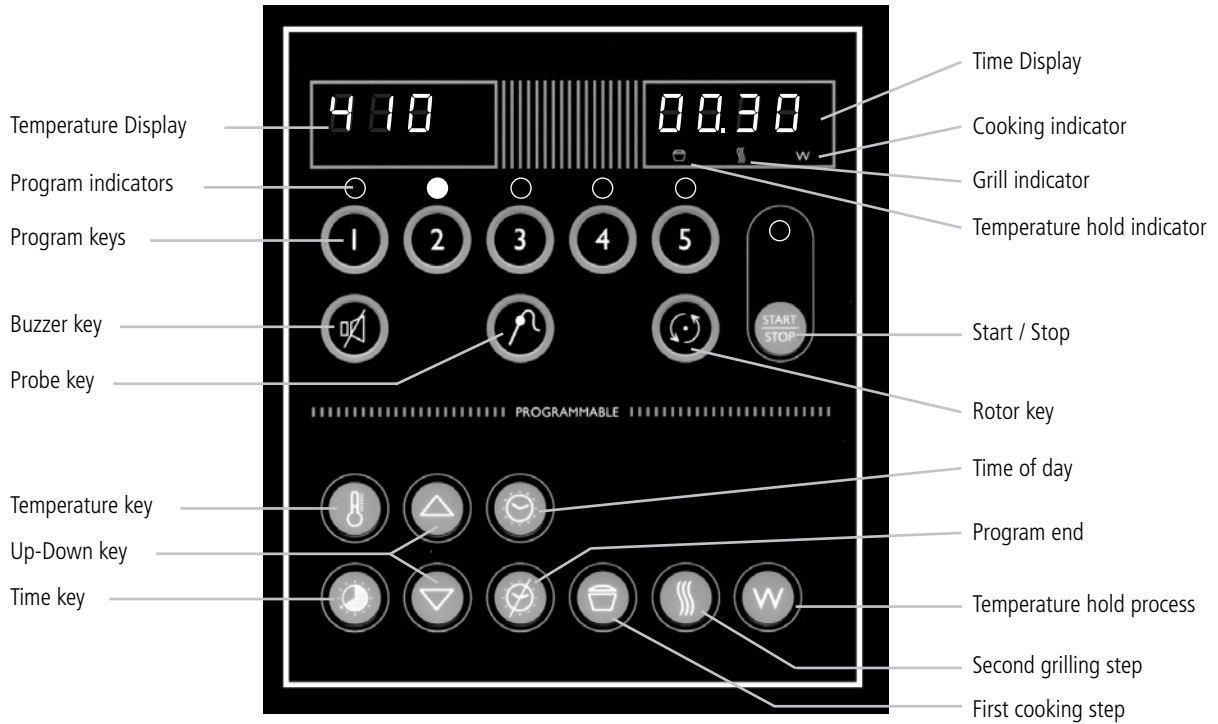

**SETTING THE ROTISSERIE**



When the main switch is turned to "1" the display lights up and the rotisserie is ON.

## SETTING ACTUAL TIME

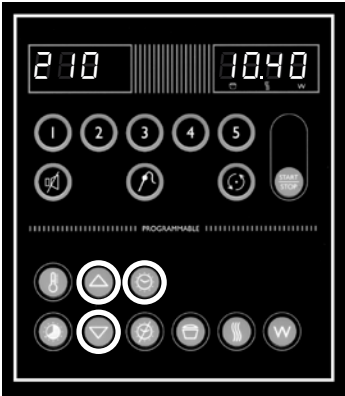

Press and hold Time of day key

Press up or down key

Release Time of day key

## 15 PROGRAMS

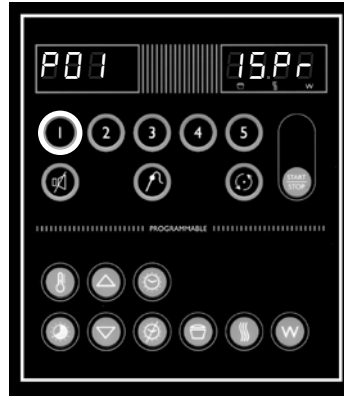

After the unit is switched-on the time display indicates: 15PR

Key 1:

1x = program 01

2x = program 06

3x = program 11

Key 2:

1x = program 02

2x = program 07

3x = program 12

## ENTERING A PROGRAM

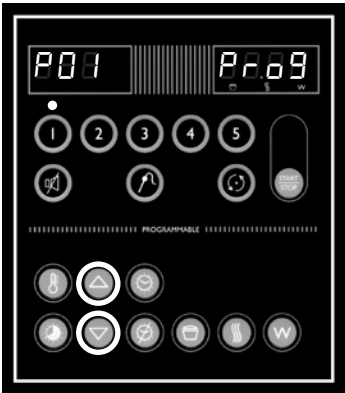

Select Program number

Press both Up and Down keys during 2 seconds

## FIRST COOKING STEP (TIME)

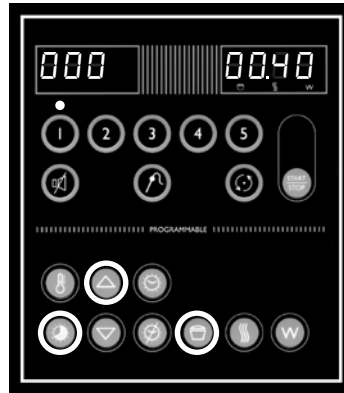

Press Cooking process key

Cooking symbol lights up

Press and hold the Time key

Press Up or Down key

## FIRST COOKING STEP (TEMP)

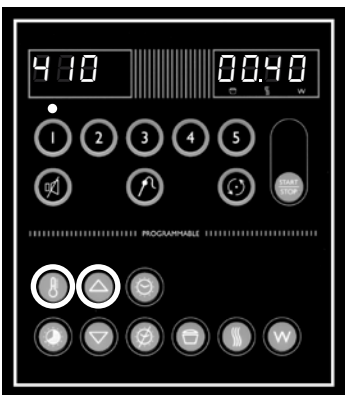

Press and hold the Temperature key

Press Up or Down key

## SECOND COOKING STEP (TIME)

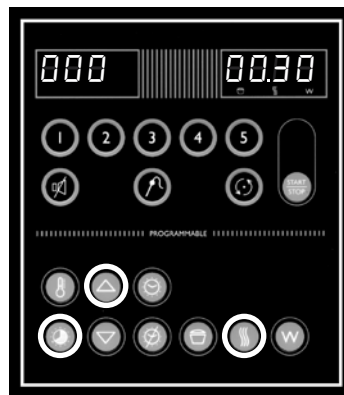

Press Grilling process key

Grilling symbol lights up

Press and hold the Time key

Press Up or Down key

## 2ND COOKING STEP (TEMPERATURE)

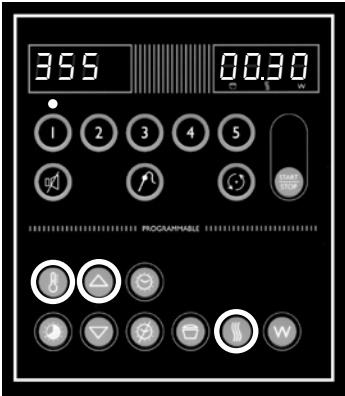

Press and hold Temperature key

Press Up or Down key

## TEMPERATURE HOLD

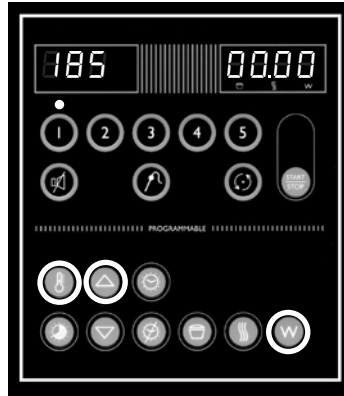

Press Temperature Hold process key

Temperature Hold symbol lights up

Press and hold the Temperature key

Press Up or Down key

## LOADING PROGRAM

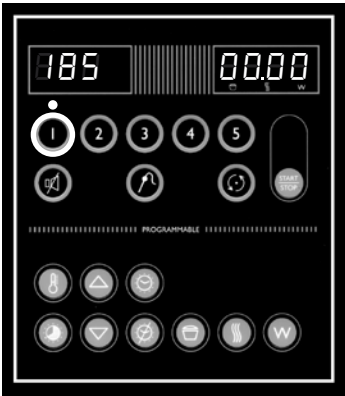

Press program number to load pre-set values

## PROGRAM START & LOADING

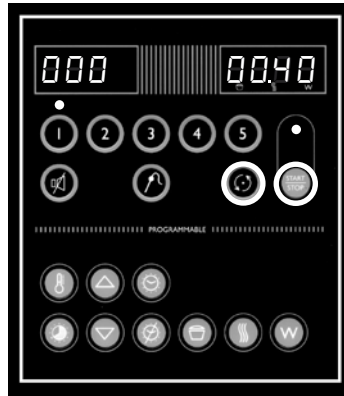

Press Start / Stop key

On indicator lights up

Press Rotor key to start turning the rotor

Press Rotor key again to stop

Load the rotisserie with products

## OPTIONAL SETTINGS

### INTERRUPTING ACTIVE PROGRAM

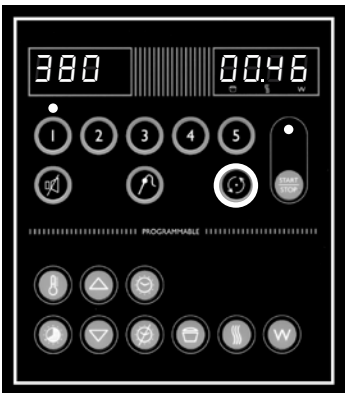

Press Rotor key

Heaters and front lamp switch off

Rotor stops

On indicator is blinking

Process time in hold

### SET ADDITIONAL BUZZER SIGNAL

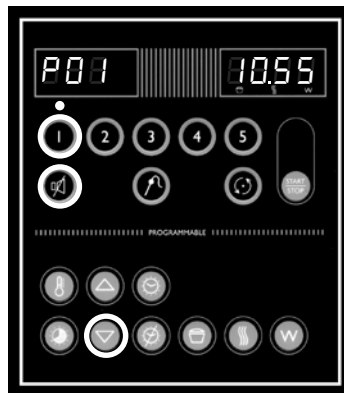

Select a pre-defined program

Press and hold Buzzer key

Press Down key

### SET PROGRAM END TIME

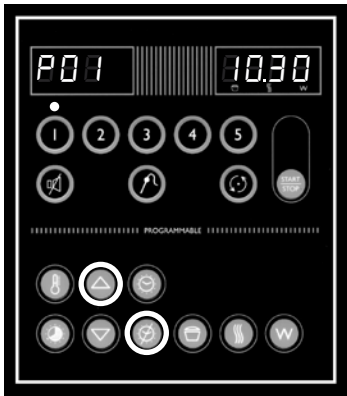

Select a pre-defined program

Press and hold the Program end key

Press Up key

### DISPLAY SET TIME & TEMPERATURE

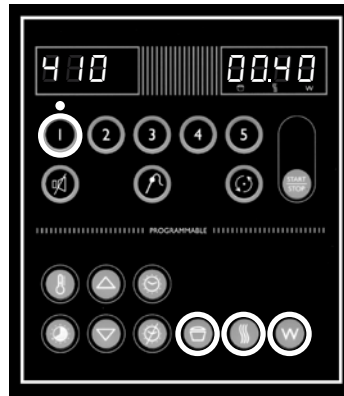

Select a pre-defined program

Press Cooking, Grilling or Temperature hold key

No time indication for Temperature hold

Visible during process or program selection

### ADJUSTING ACTIVE PROGRAM

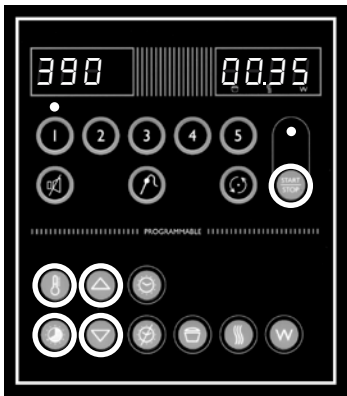

Press and hold Temperature or Time key

Adjust temperature or time with Up or Down key

### PREHEAT INDICATION

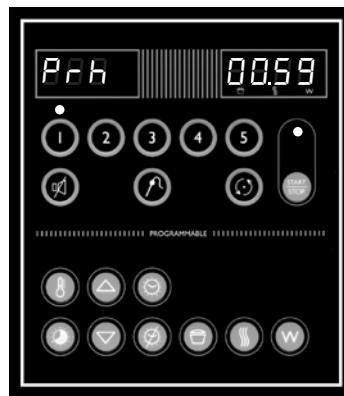

Under 40°C (104°F) the display shows PRH

### TEMPERATURE PROBE (OPTIONAL)

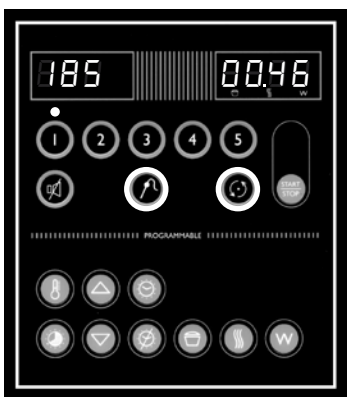

Press the Rotor key

Insert the probe in the meat up to the core

Press Temperature sensor key; after 20 seconds the temperature reading switches off

### INDICATIONS DURING PROCESS

- Process indicators shows actual process after completion indicator switches off
- Time display shows remaining program time which is the sum of the remaining cooking and grilling time
- Temperature display indicates actual temperature in the grill. Under 40°C (104°F) the display shows PRH (preheat)
- When remaining time reaches 0, the process indicators and the On-indicator switches off

## REMOVAL AND REPLACEMENT OF PARTS

**WARNING:** Disconnect the electrical power to the machine at the main circuit box. Place a tag on the circuit box indicating the circuit is being serviced. Follow OSHA Lockout/Tagout procedures.

## RIGHT OR LEFT SIDE PANEL



1. Remove the 4 screws that secure the panel to the frame.
2. Remove the panel.
3. Reverse the procedure to install.

## TOP COVER

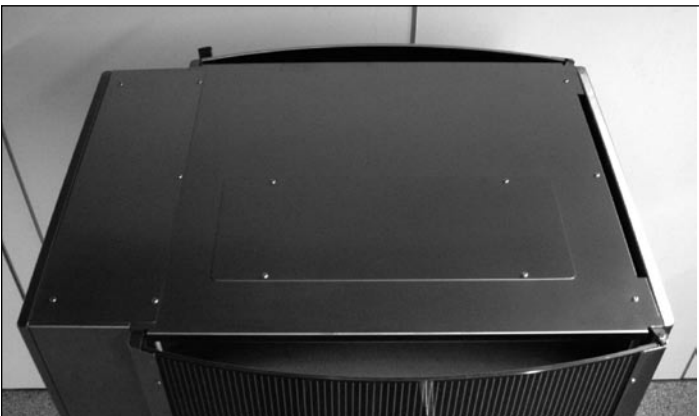

1. Remove the left side panel according prior procedure.
2. Remove the 4 screws from the cover plate and remove this plate.
3. Remove the 6 screws from the top cover.
4. Remove the top cover. (Lift at left side and remove to the left).
5. Reverse the procedure to install.

## KNOB



1. Remove cover plate on the knob with a small screw driver.
2. Loosen the screw inside the knob.
3. Remove the knob and ring.
4. Reverse the procedure to install.

**Note** that the ring behind the knob is in the right position and runs free from the panel.

## INSTRUMENT PANEL

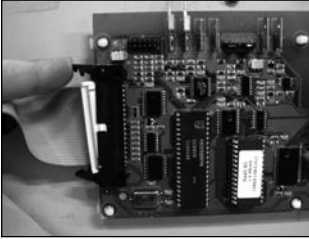

1. Remove the right side panel according prior procedure.
2. Remove the knobs according prior procedure.
3. Remove the screws that secure the panel.
4. Remove the 2 bolts on the backside of the instrument panel (top and bottom side).
5. Remove the screws that secure the meat probe holder and remove the holder (if supplied).
6. Remove the flatcable on the power section.
7. Remove the clip on the back, top left side that secures panel and frame.
8. Remove the instrument panel.
9. Reverse the procedure to install.

## ELECTRIC PANEL

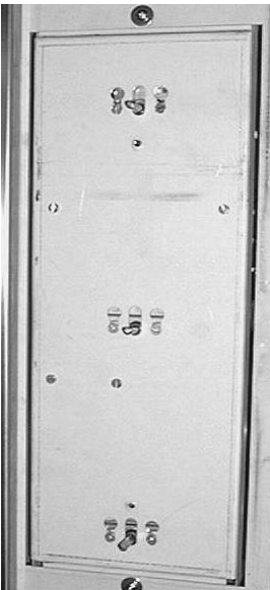

1. Remove the instrument panel according prior procedure.
2. Remove on the front side the screws that secure the panel.
3. Remove on the inside bottom of the electric panel the bolt and nuts.
4. Disconnect the wiring.
5. Slide the electrical panel backwards.
6. Reverse the procedure to install.

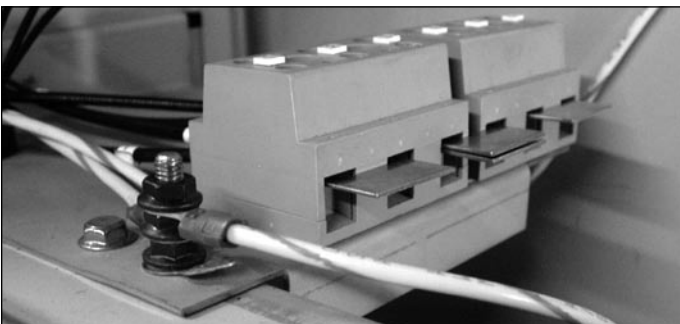

## DISPLAY

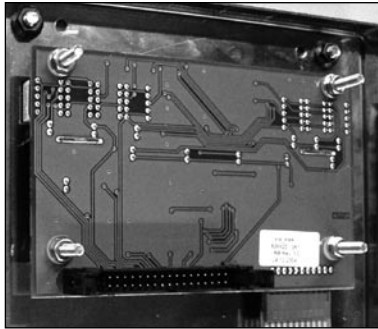

1. Remove the right side panel according prior procedure.
2. Disconnect the flatcable on the display.
3. Remove the clip on the back, top left side that secures panel and frame.
4. Remove the nuts and washers on the backside of the display and remove the metal cover.
5. Remove the nuts and plastic rings that secure the board and remove the board. Do not forget to disconnect the blue connector on the board.
6. Reverse the procedure to install.

## PANEL AND KEYPAD ASSEMBLY

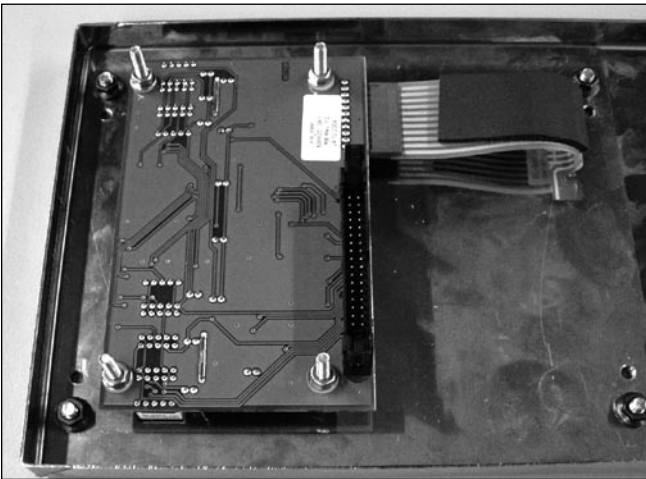

1. Remove the instrument panel according prior procedure.
2. Remove the display according prior procedure.
3. Remove the nuts that secure the panel with foil and remove panel.
4. Reverse the procedure to install.

## NAMEPANEL



1. Remove the instrument panel according prior procedure.
2. Remove the 4 nuts that secure the panel and remove panel.
3. Reverse the procedure to install.

## QUARTZ LAMP

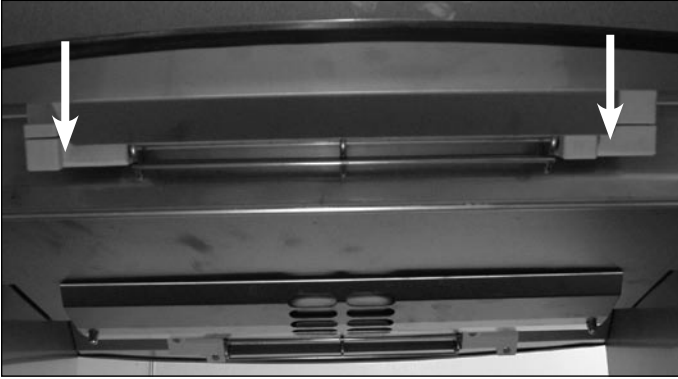

**Caution:** Do not touch the glass with your hands. The moisture from your hands could affect the live span of the lamp. This moisture can be removed with alcohol while the lamp is cold.

**Note:** Use a clean rag or paper towel to replace the lamp.

1. Remove the insulators of the lamp.
2. Remove the bolt from each end of the lamp and remove the lamp.
3. Install the lamp with the painted side towards the top of the oven. Hold the metal when tightening the bolts to prevent the metal from twisting and damaging the lamp.
4. Tighten the insulators evenly to prevent damage.

## POWER SECTION

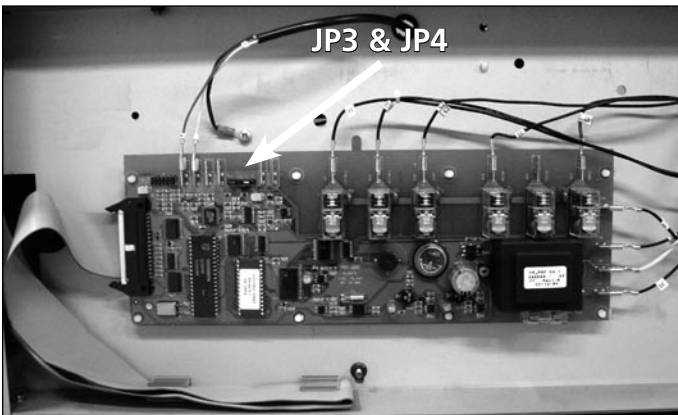

1. Remove the right side panel according prior procedure.
2. Disconnect wiring and flatcable on the board.
3. Remove the board from the clips by pressing the clips together.
4. Reverse the procedure to install.

**Note:** When installing new board, ensure that JP3 and JP4 on new board are set the same as on the old board.

## HIGH LIMIT THERMOSTAT

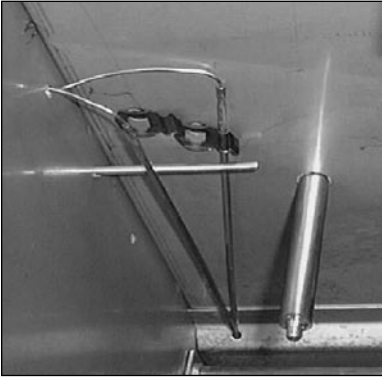

1. Remove the right side panel according prior procedure.
2. Remove the suction and fan plate on the inside of the oven.
3. Remove the thermostat-probe from the clip in the oven and guide it outside through the opening in the side wall.
4. Remove the screws on the electric panel that secure the thermostat.
5. Remove the thermostat and disconnect the wiring.
6. Reverse the procedure to install.

**Note:** Set the new high limit thermostat to its maximum position.

## THERMOSTAT

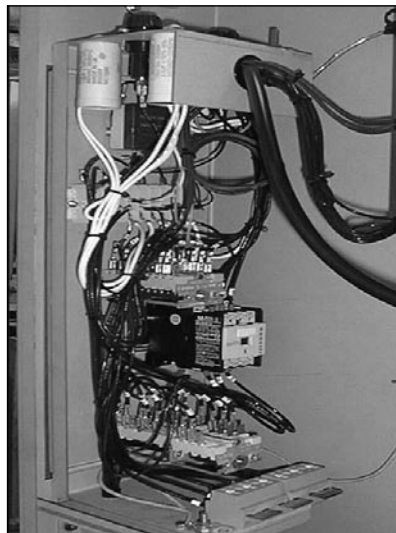
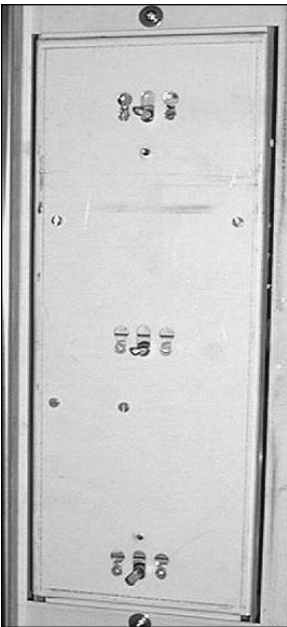

1. Remove the instrument panel, suction and fan plate on the inside of the oven according prior procedures.
2. Remove the thermostat-probe from the clip in the oven and guide it outside through the opening.
3. Loosen the 2 screws on the electric panel that secure the thermostat.
4. Remove the thermostat and disconnect the wiring.
5. Reverse the procedure to install.

## ROTOR OR MAIN SWITCH

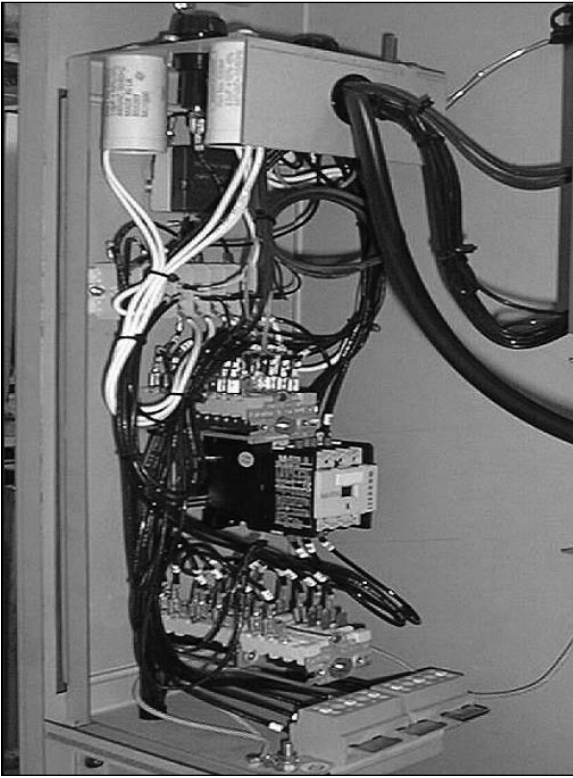

1. Remove the instrument panel according prior procedure.
2. Loosen the screws on the electric panel that secure the switch.
3. Remove the switch and disconnect the wiring.
4. Reverse the procedure to install.

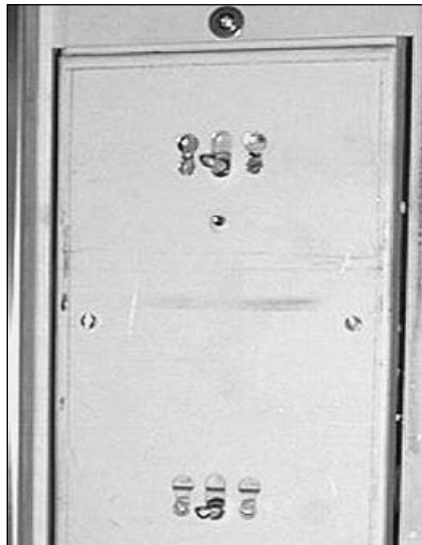

## CONTACTOR



1. Remove the right side panel according prior procedure.
2. Disconnect the lead wires to the switch.
3. Push down on the locking tab and lift out and then up to remove it from the mounting bracket.
4. Reverse the procedure to install.

## BLOWER MOTOR

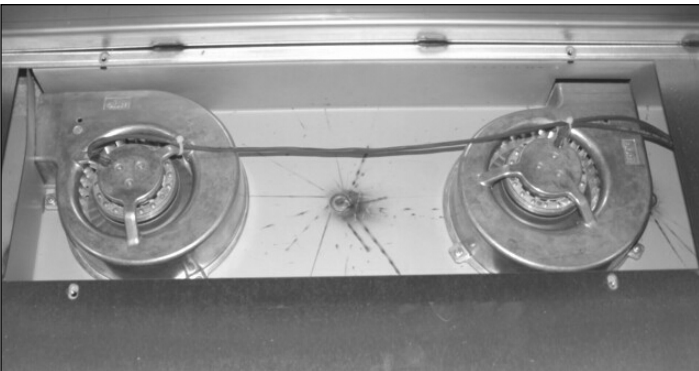

1. Remove the right side panel and the top cover according to prior procedures.
2. Remove the rotor discs, suction and fan plate in the oven.
3. Remove the wing nut on the fan blade and remove fan blade. (Left handed threads)
4. Disconnect wiring of the motor.
5. Remove the screws that secure the motor and remove the motor.
6. Reverse the procedure to install.

**Note:** The blowers are equipped with a capacitor. Check the direction of rotation of the motor (clockwise) and change the wiring if necessary.

## BLOWER MOTOR BOTTOM ROTISSERIE (STACKED MODELS)

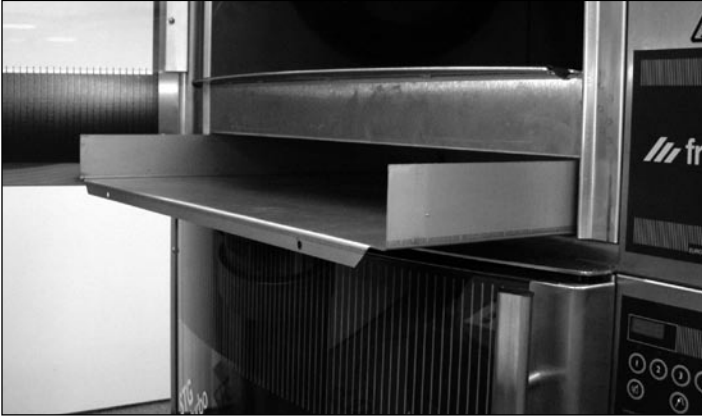

1. Remove the right side panel according prior procedures.
2. Remove the rotor discs, suction and fan plate in the bottom oven.
3. Remove the wing nut on the fan blade and remove fan blade. Left handed threads.
4. Remove fat drawer from upper oven.
5. Remove the bolts that secure the intermediate plate and remove this plate.
6. Remove the drip trays from the upper oven.
7. Remove the bolts that secure the top plate and remove the top plate.
8. Disconnect wiring of the motor.
9. Remove the screws that secure the motor and remove the motor.
10. Reverse the procedure to install.

**Note:** *The blowers are equipped with a capacitor. Check the direction of rotation of the motor (clockwise) and change the wiring if necessary.*

## PT500 SENSOR

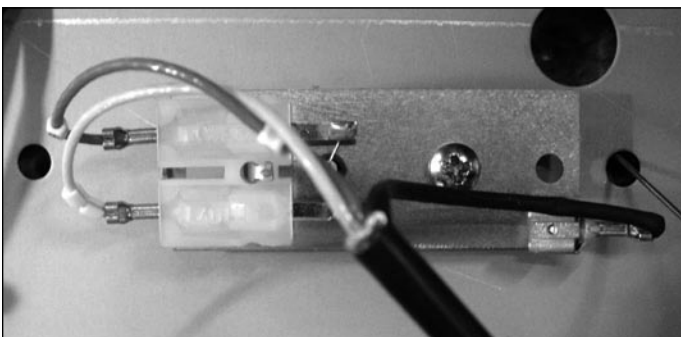

1. Remove the right side panel according to prior procedure.
2. Disconnect the wiring of the sensor.
3. Remove the screw that secures the sensor and remove the sensor.
4. Reverse the procedure to install.

**Note:** *The wiring cable is an insulated cable with an earthing screen.*

## HEATING ELEMENT

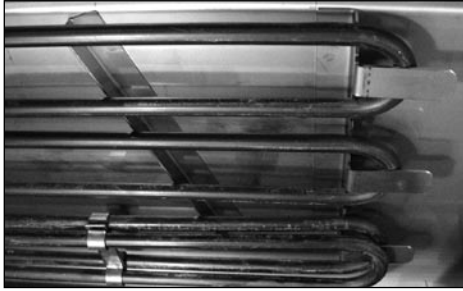

1. Remove the rotor discs, right side panel, suction and fan plate according prior procedures.
2. Disconnect the wiring from the element.
3. Remove the mounting nut.
4. Remove the element from the mounting clip and pull it from the wall.
5. Reverse the procedure to install.

## DRIVE MOTOR

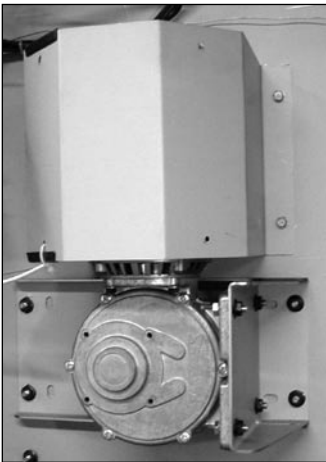

1. Remove the right side panel and rotor discs according prior procedure.
2. Disconnect the wiring of the motor. Check where the wire, marked A is connected.
3. Remove the screws that secure the fan cover and remove the cover.
4. Set the drive arm in a position vertical downwards. This can be done manually or by turning the fan blade by hand.
5. Mark the position of the motor support with a marker.
6. Remove the bolts that secure the motor and the nuts that secure the motor support and remove the motor.
7. Check the white Teflon ring. Replace if necessary.
8. Install the fan blade on the new motor.
9. Reverse the procedure to install.

**Note:** Always make a test run on maximum temperature to insure the motor is well mounted and adjusted.

## DOOR ADJUSTMENT (LEFT SIDE)

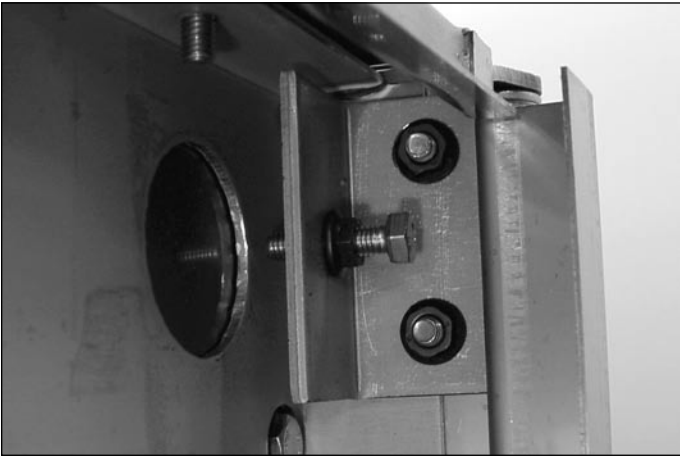

1. Remove the left side panel according prior procedure.
2. Loosen the nuts of the upper hinge. The door must be closed.
3. Loosen the locknut and adjust the bolt in or out to adjust the door.
4. Tighten the nuts of the hinge and mount the left-hand panel.

## DOOR GLASS INSIDE



1. Lift the door upward out of the hinges and place on a table.
2. Remove the cap nuts and rings on the profiles of the door.
3. Remove the profiles from the glass.
4. Mount the profiles on the new glass. Do not forget the teflon rings inside the holes.
5. Mount the cap nuts and rings. Note! Tightening of nuts max.3.1 lbf.ft.
6. Place the door in the hinges.

## DOOR GLASS OUTSIDE



1. Lift the inner door out of the hinges and lay aside.
2. Remove the left side panel according prior procedure.
3. Remove the 2 nuts behind the top hinge. The door must be closed.
4. Hold the door on both sides and move this towards yourself, before lifting it out of the hinges. Place the door with the rounded side down on a table.
5. Remove the screws, cap nuts and rings on the profiles of the door and remove the profiles.
6. Mount the profiles on the new glass. Do not forget the teflon rings inside the holes.
7. Reverse the procedure to install.

## ELECTRICAL TESTS AND SERVICE PROCEDURES

**WARNING:** Disconnect the electrical power to the machine at the main circuit box. Place a tag on the circuit box indicating the circuit is being serviced. Follow OSHA Lockout/Tagout procedures.

**PT500 SENSOR TEST**

Temperature		Resistance
°F	°C	± 5 Ohms
60	16	531
70	21	541
80	27	553
90	32	562
100	38	574
125	52	601
150	65	626
200	94	681
250	121	732
350	177	837
450	233	940

1. Remove the right side panel according prior procedure.
2. Remove the wiring from the sensor.
3. Connect a temperature sensor to the probe for comparison.
4. Test the probe with an Ohmmeter.

**HEATING ELEMENT TEST**

Type	Wattage/Voltage	Resistance $\Omega$ -5% + 10%	Current A
FJ7500	2100 / 208	20.5	10.0
	2100 / 230	25.0	9.1
FJ7500	3100 / 208	14.0	14.9
	3100 / 230	17.0	13.4

**Note:** When testing the resistance of the element remove the wiring.

## KEYPAD TEST

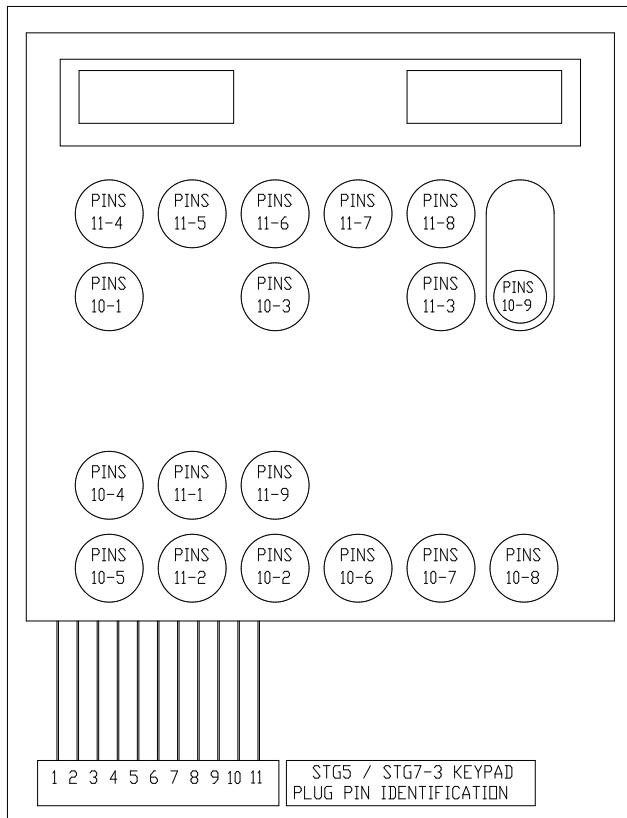

1. Remove the instrument panel according prior procedure.
2. Remove the display according prior procedure.
3. Remove the nuts that secure the panel with foil and remove panel.
4. Use a multimeter to test. Connect the measuring pins to the cable plug pins for each key to be tested as indicated in the diagram. You can set the multimeter on a beep signal or set it on resistance measuring. Press the key to be tested and the meter should give a beep signal or indicates a resistance less than 200 Ohms.

**CONTROL LOCATION**

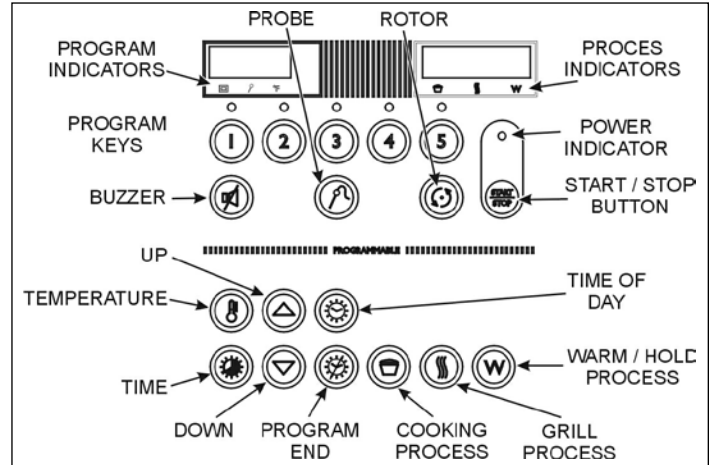
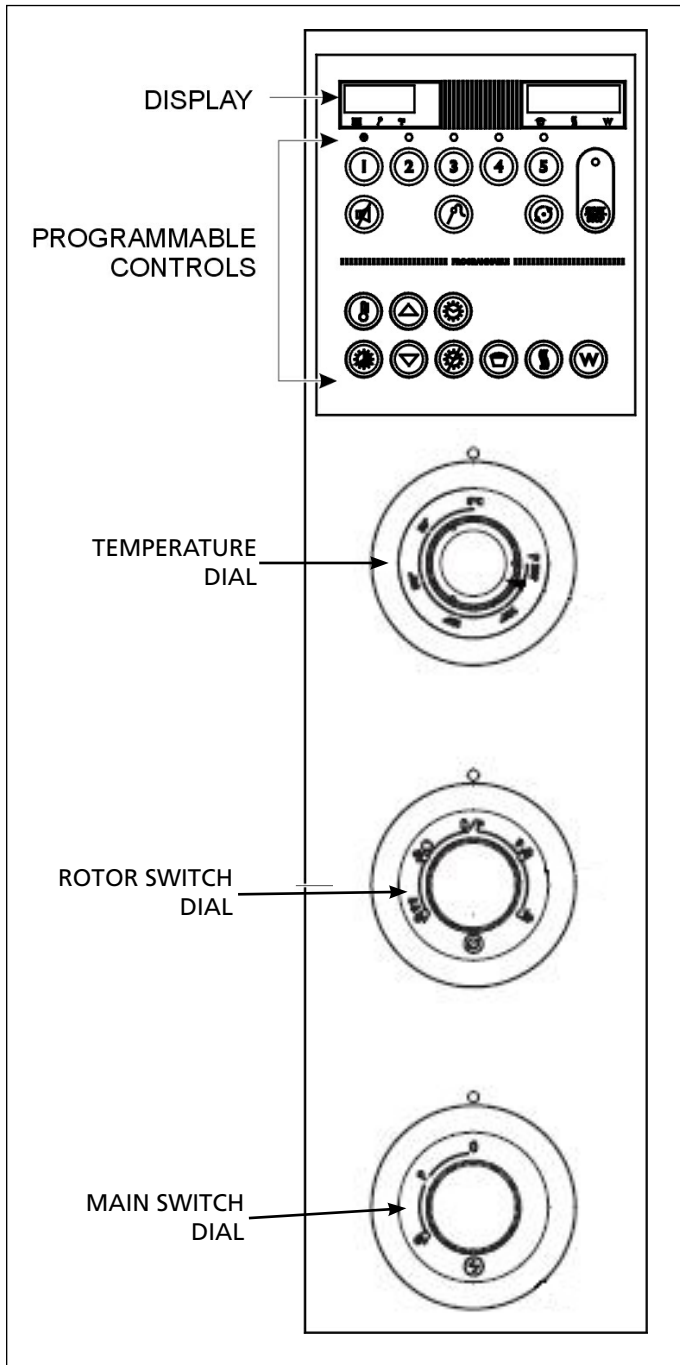

## PART 1: GENERAL TROUBLESHOOTING LIST

## TROUBLESHOOTING

Symptom	Possible causes
No power to oven controls.	<ol style="list-style-type: none"> <li>1. Main breaker open.</li> <li>2. Fuse F3 burned.</li> <li>3. Switch malfunction</li> <li>4. Wiring loose.</li> </ol>
Main fuse or breaker blows.	<ol style="list-style-type: none"> <li>1. Wiring incorrectly.</li> <li>2. Heating element, drive motor, blower or contactor shorted.</li> <li>3. Wiring shorted.</li> </ol>
Drive motor does not run in either auto or manual mode.	<ol style="list-style-type: none"> <li>1. Main braker on L3 open (also no readings on display).</li> <li>2. Fuse F3 burned (also no readings on display).</li> <li>3. Fuse F1 or F2 burned</li> <li>4. Capacitor malfunction.</li> <li>5. Wiring loose.</li> <li>6. Rotor switch malfunction.</li> <li>7. Main switch malfunction.</li> <li>8. Motor malfunction.</li> </ol>
Drive motor does not run in manual mode but runs in auto mode.	<ol style="list-style-type: none"> <li>1. Rotor switch malfunction.</li> <li>2. Main switch malfunction.</li> <li>3. Wiring loose.</li> </ol>
Drive motor does not run in auto mode but runs in manual mode.	<ol style="list-style-type: none"> <li>1. Fuse F3 (also no readings on display).</li> <li>2. Power board malfunction (relay).</li> <li>3. Wiring loose.</li> </ol>
Blower motor does not run.	<ol style="list-style-type: none"> <li>1. Capacitor malfunction.</li> <li>2. Motor inoperative.</li> <li>3. Relay on power board malfunction.</li> <li>4. Powerboard malfunction (relay).</li> </ol>
Oventemperature differs from temperature setting in auto or manual mode.	<ol style="list-style-type: none"> <li>1. Safety thermostat malfunction.</li> <li>2. Thermostat malfunction.</li> <li>3. Blower motor(s) inoperative (turning direction?)</li> <li>4. Electronic control inoperative.</li> <li>5. Rotorswitch and thermostat in auto mode, but main switch in manual. (temperature too high).</li> <li>6. PT-500-sensor malfunction.</li> <li>7. Dirty fanguard or fanblade(s).</li> </ol>
All heating elements out, one quartzlamp and blowers operate while oven cavity is below set temperature.	<ol style="list-style-type: none"> <li>1. Thermostat malfunction.</li> <li>2. Safety thermostat malfunction.</li> <li>3. Contactor inoperative.</li> <li>4. Wiring loose.</li> </ol>
Oven temperature does not reach desired temperature in auto mode.	<ol style="list-style-type: none"> <li>1. Control thermostat not in auto or malfunction.</li> <li>2. Safety thermostat malfunction.</li> <li>3. PT-500-sensor malfunction.</li> <li>4. Electronic control inoperative.</li> <li>5. Heater(s) inoperative.</li> <li>6. Incorrect line voltage.</li> </ol>
No display and/or keypad does not function.	<ol style="list-style-type: none"> <li>1. Loose flatcable from display to electronic control.</li> <li>2. Fuse F4 (63mA) burned.</li> <li>3. Fuse F3 (10A) burned.</li> <li>4. Display and/or electronic control malfunction.</li> </ol>

## PART 2: ANALYTIC TROUBLESHOOTING LIST

### SERVICING AND REPAIRING

This is an analytic description for servicing and repairing all major parts of the rotisseries and warmers. It consists off 4 basic steps to recognize and solve the problems. These steps are:

1. Symptoms.
2. Possible causes.
3. Solving of the problem: checking/action.
4. Replacing of parts and testing.
  - a. Replacing is described in the service manual.
  - b. For testing see programming of rotisserie on page 5 in this manual.

Description of part	Symptoms	Possible causes	Solving: checking/action
Inside door	Broken glass	Slamming of door.  Fastening bolts and nuts are loose.  No sealing ring between steel and glass.	Give instruction to operator.  Tighten all fastenings.  Mount new glass with sealing rings between glass and steel.
Outside door	Broken glass       Door adjustment	Slamming of door.  Fastening bolts and nuts are loose.  No sealing ring between steel and glass.  Door not well adjusted and closes against bottom side.	Give instruction to operator.  Tighten all fastenings.  Mount new glass with sealing rings between glass and steel.  Adjust door on hinge and tighten the hinge plate.
Heating element	Rotisserie doesn't reach adjusted temperature      Duration of grilling time is too long	Wiring.  Element malfunction.  Wiring.  Element malfunction.	Check the wiring. Check the power on the element.  Check the current with AC current tester. See table on page 20.  Check the wiring.  Check the current with AC current tester. See table on page 20.

<p>PT-sensor</p>	<p>Temperature indication on display runs up very fast and over the maximum of 250°C / 482°F 290°C / 550°F in 20 seconds)</p> <p>Temperature indication on display doesn't go up and stays on Prh</p> <p>Rotisserie doesn't reach adjusted temperature</p> <p>Temperature indication on display runs up too fast.</p>	<p>No connection between wires.</p> <p>Full contact between wires of sensor.</p> <p>Short circuit in sensor.</p> <p>Malfunction sensor.</p> <p>Sensor not in right position.</p> <p>Malfunction sensor.</p>	<p>Check the wiring. Check thin wire on sensor.</p> <p>Check the wiring.</p> <p>Measure resistance of sensor. This is zero.</p> <p>Measure resistance of sensor with a thermometer probe next to the sensor. See table in service manual.</p> <p>Check position of sensor.</p> <p>Measure resistance of sensor. See table on page 20.</p>
<p>(Safety) thermostat</p>	<p>Contactor doesn't come in after starting of program</p> <p>Contactor switches off before reaching the adjusted temperature in program</p>	<p>Wiring.</p> <p>Thermostat malfunction.</p> <p>Thermostat malfunction.</p> <p>Thermostat probe not in right position.</p>	<p>Check the wiring.</p> <p>Check if the thermostat is making contact.</p> <p>Check if the thermostat is turned fully clockwise (contact closed).</p> <p>Check the position of the thermostat probe.</p>
<p>Main switch/rotor switch</p>	<p>No power to all, or some oven controls</p> <p>Switch comes in, but one or more functions from the switch don't work.</p>	<p>Wiring.</p> <p>Malfunction of the cams on the switch.</p> <p>Contacts burned.</p>	<p>Check the wiring on the switch.</p> <p>Check the cams.</p> <p>Check the wiring. Check the power on all contacts.</p> <p>Check the contacts of the switch.</p>
<p>Contactor</p>	<p>Contactor doesn't come in</p>	<p>Wiring.</p> <p>Coil malfunction.</p> <p>Contact burned.</p>	<p>Check the wiring.</p> <p>Check resistance of the coil. This should be 525Ω.</p> <p>Check the contacts of the contactor.</p>
<p>Keypad on display</p>	<p>No possibility to make a program</p>	<p>Permanent contact of one, or more, membrane keys.</p> <p>Some keys don't function.</p>	<p>Check key functions. Check functions of keypad. See table on page 21.</p> <p>Check grey flat cable connection. Check green flat cable connection. Check functions after connecting a new grey flat cable.</p>

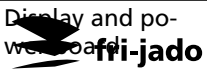
		TROUBLESHOOTING	
 Display and power board	No illumination on display	Wiring.	Check the wiring. Check the power on the board.
	Some function doesn't work or stay activated.  No possibility to make a program	Fuse burned.  Flat cable.  Display malfunction.  Power board malfunction.  Relay malfunction.  Power board malfunction.	Check the 63 mA fuse on the power board. Replacing of fuse for 100 mA is permitted.  Check grey flat cable connection. Check functions after connecting a new grey flat cable.  Check power to display on connector J1 of power board. 5V DC between pin 30 and 32 or between 31 and 33.  Check functions after connecting a new display board.  Check functions after connecting a new power board.  Check relay on function with problem.  Check functions after connecting a new power board.
Capacitor	Drive motor or blower don't work	Wiring.  Capacitor malfunction.	Check the wiring.  Check function after connecting a new capacitor. Checking of capacitor: Discharge capacitor with screwdriver. Set meter on MΩ and connect the pins of the meter on contacts, value runs up. Change the pins on contacts, value runs up again. This means the capacitor is OK.
Drive motor	Motor doesn't run      Motor runs after starting it up by hand  Motor stops during process and comes in again after a period of time   Fuse F1 or F2 burned	Wiring.  Coil malfunction  Reduction gearbox.  Relay on power board.  Capacitor malfunction.  Coil overheated, thermistor switches off (105°C – 221°F).  Short circuit in coil to earth	Check the wiring. Check the power to the motor.  Check resistance of the coils. Between whiteA and white wire 234Ω Between whiteA and brown wire 117Ω Between white and brown wire 117Ω  Check if reduction gearbox is blocked.  Check power on relay X14.  Check capacitor (see capacitor) or connect new capacitor.  Check position of fan blade. Air is sucked up over the motor. Check cooling circuit of motor. Check if rotisserie is close to another heat source. Measure temperature motor during process.  Check insulation value of coil with Megger on 500V. Minimum value is 0.5 MΩ.

Blower	Blower doesn't run	Wiring.	Check the wiring. Check the power on the blower.
		Coil malfunction.	Check resistance of the coils. Between blue and brown wire 310Ω; Between blue and black wire 320Ω; Between brown and black wire 630Ω
		Relay on power board.	Check power on relay X9 and X10
	Blower runs after starting it up by hand	Capacitor malfunction.	Check capacitor (see capacitor) Or connect new capacitor.
	Blower stops during process and comes in again after a period of time	Coil overheated, thermistor switches off (150°C – 302°F).	Check cooling circuit of blower. Check if rotisserie is close to another heat source. Measure temperature blower during process.
Temperature indication on display runs up very fast (180°C - 355°F after 5 minutes)	Blower doesn't turn and heat stays in top of cavity	Check the wiring. Check the power on the blower.	
Fuse F1 or F2 burned	Short circuit in coil to earth	Check insulation value of coil with a Megger on 500V. Minimum value is 0.5 MΩ.	



Item	Partnumber	QTY	Description
1	9170448	1	Frame, ass.
2	9170404	1	Heat shield
3	9170419	1	Side panel, left
4	9174005	1	Cover, removable
5	9170421	2	Side panel, top
6	9170531	1	Side panel, right
7	9073149	3	Wingnut M6, SS
8	4288322	8	Screw M5 x 10, SS socket button head
9	9170425	1	Reinforcement, side plate, right
12	9170444	1	Support, gear motor
13	9170450	1	Mounting plate, blower
14	9170451	1	Drawer
15	9174615	1	Operation panel
16	9174031	1	Panel, customer side
20	9174004	1	Cap, top
21	9172202	1	Bottom plate, coated
21	9174010	1	<b>Bottom plate, stainless steel</b>
22	9174013	1	Reinforcement, side plate, left
23	9174015	1	Cover plate, machine components
24	9174016	1	Ceiling
27	9172066	2	<b>Castor with brake (only for stacked units)</b>
28	9172065	2	<b>Castor without brake (only for stacked units)</b>
29	9174099	1	Cover, removable
30	9170640	1	Cover plate, blower
31	9111913	1	Air guide plate
32	9174034	1	Mounting plate
40	9171125	4	Leg, rubber 1 15/16"
40A	9011260	4	Leg, rubber 1 9/16" (till 01-01-2008)
54	9172232	1	Bottom plate, coated
54	9174280	1	<b>Bottom plate, stainless steel</b>
57	9112430	4	Washer, insulation support
58	9172053	8	Nut
59	9171008	1	Drain-tap with handle
64	9174146	1	Protection plate, electric components
65	9170505	1	Back wall, outside
66	9172231	1	Back wall, inside
98	9172116	2	Sealing profile, Silicon L= 71 cm
100	9174140	1	Spark catcher
101	9123410	1	Indication plate

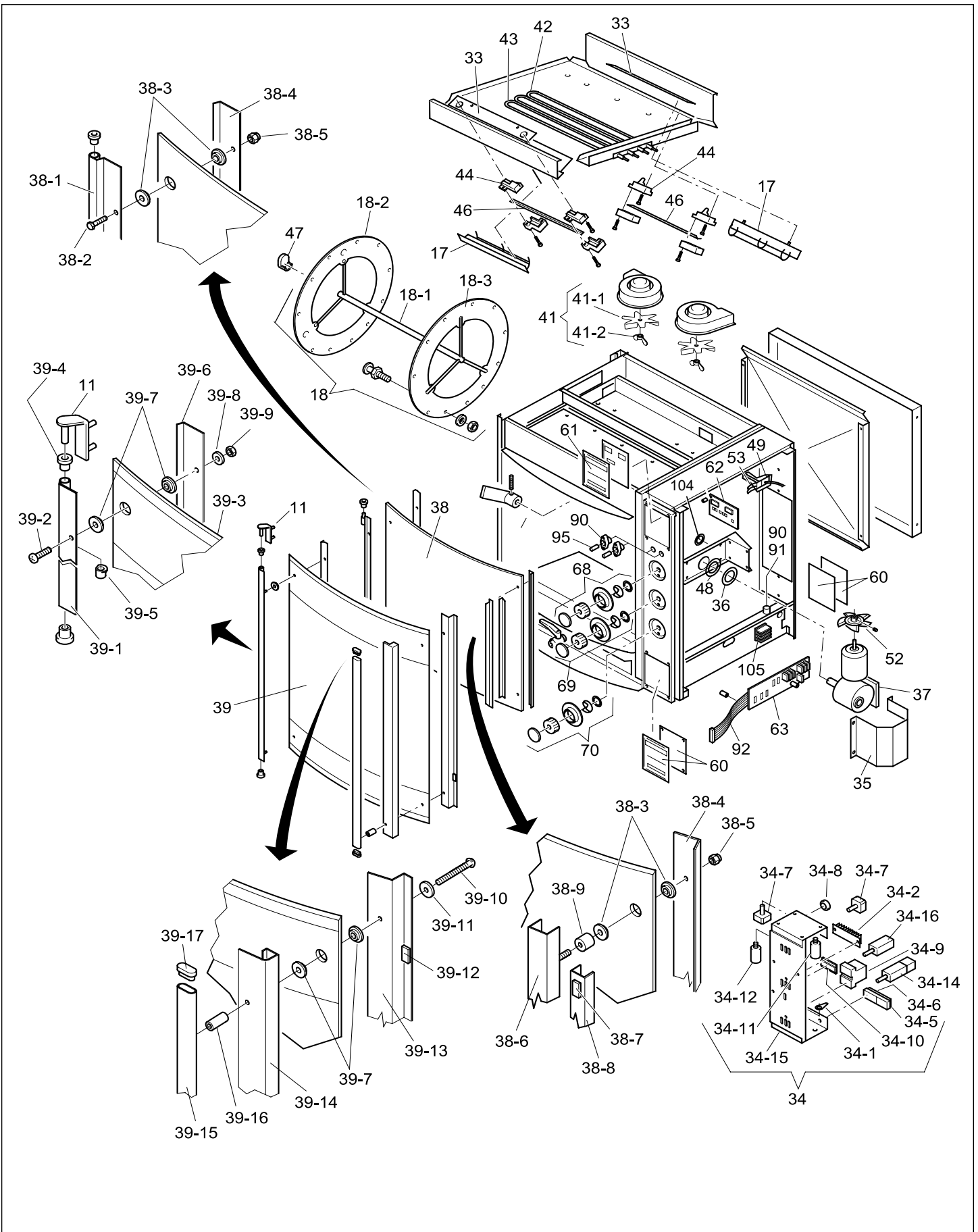

FJ7500 - COMPONENTS

Item	QTY	Partnumber	Description
11	1	9170427	Hinge, left
17	2	9116662	Protection, lamp
18	1	9170045	Rotorset ass., coated
18-1	1	9172205	Rotor shaft, ass., coated
18-2	1	9172248	Rotor disc, left, coated, incl. support pins
18-3	1	9172249	Rotor disc, right, coated, incl. support pins
18	1	9170055	<b>Rotorset ass., stainless steel</b>
18-1	1	9070272	<b>Rotor shaft, stainless steel</b>
18-2	2	9174351	<b>Rotor disc 3 mm, stainless steel</b>
18-3	14	9172169	<b>Supprt pin, stainless steel</b>
18-4	14	4312271	<b>Nut M8, supprt pin, stainless steel</b>
18-5	14	0142056	<b>Spring washer M8, support pin, stainless steel</b>
18-6	12	4288230	<b>Tensilock bolt M5x10, stainless steel</b>
33	2	9112210	Mounting plate, lamp holder
34	1	9173002	Electric panel, ass.
34-1	1	0166555	Earth symbol
34-2	1	8033659	Connecting block, 9-pol.
34-5	1	9044564	Connecting block, 1,2,3
34-6	1	9044572	Connecting block, 4,5,6
34-7	1	9070531	Thermostat 50-250 °C
34-8	2	9070840	Grommet
34-9	1	3500069	Contactora
34-10	1	9077088	Bracket, magnetic switch
34-11	1	9077102	Capacitor 3 mF
34-12	2	9110030	Capacitor 1,5 mF
34-14	1	9172056	Main switch
34-15	1	9174106	Electric panel
34-16	1	9172055	Rotor switch
35	1	9174161	Protection support
36	1	9110797	Sealring, drive bearing
37	1	9173004	Gearmotor, complete with drive arm
38	1	9179852	Door inside, ass.
38-1	1	9170423	Hinge profile
38-2	2	0211520	Bolt M5 x 12 ss hexagon head
38-3	8	3702341	Flange bush, PTFE 2 mm
38-4	2	9174029	Cover profile, inner glass
38-5	4	4285408	Nut, M5
38-6	1	9174026	Holder, magnet
38-7	10	9070141	Magnet block
38-8	1	9174027	Profile
38-9	2	9172081	Spacing pin

Item	QTY	Partnumber	Description
39	1	9179850	Door outside, ass.
39-1	1	9170422	Hinge profile
39-2	2	4288321	Screw M5 x 16, SS socket button head
39-3	2	9172079	Protection profile
39-4	2	9172054	Brass bearing 8 mm
39-5	2	9172122	Brass bearing 8 mm, adjusted
39-6	1	9174022	Mounting profile, hinge side
39-7	8	3702342	Flange bush, PTFE 3 mm
39-8	2	4311110	Washer
39-9	2	0144359	Nut, self locking M5
39-10	2	4288320	Screw M5x45 SS
39-11	2	9174680	Washer
39-12	12	9070141	Magnet block
39-13	1	9174025	Fastening, door handle
39-14	1	9170454	Profile, magnet
39-15	1	9174131	Door handle
39-16	2	9172300	Spacing pin
39-17	2	9171014	Plug, door handle
41	2	9110048	Blower
41-1	2	9110153	Fanblade
41-2	2	9073150	Wingnut, left hand threaded
42	2	9040633	Heating element 208 V, 2100 W
43	1	9110909	Heating element 208 V, 3100 W
44	4	9110023	Lamp holder, cap + housing
46	2	9056082	Quartz light, 1000 W
47	1	9172063	Steel bearing, 14 mm
48	1	9073131	Sealing ring
49	1	9070094	Temperature sensor
52	1	9172078	Fanblade, motor
53	1	9044140	Sensor cable
60	2	9172043	Name plate , foil + backplate
61	1	9172045	Keypad + backplate
62	1	9110242	Display
63	1	9110276	Power section
68	1	9173015	Thermostat knob assembly, 480°F
69	1	9173013	Rotor knob assembly
70	1	9173014	Main power knob assembly
78	4	3702342	Flange bush, PTFE 3 mm
90	3	9044205	Fuse holder
91	1	9110250	Fuse SC10, 10A
92	1	9172113	Flatcable, 34-pol. (P)
95	2	9044213	Fuse SC10, 3A
104	3	9171018	Plug
105	1	9151010	Connecting block

ELECTRICAL DIAGRAMS

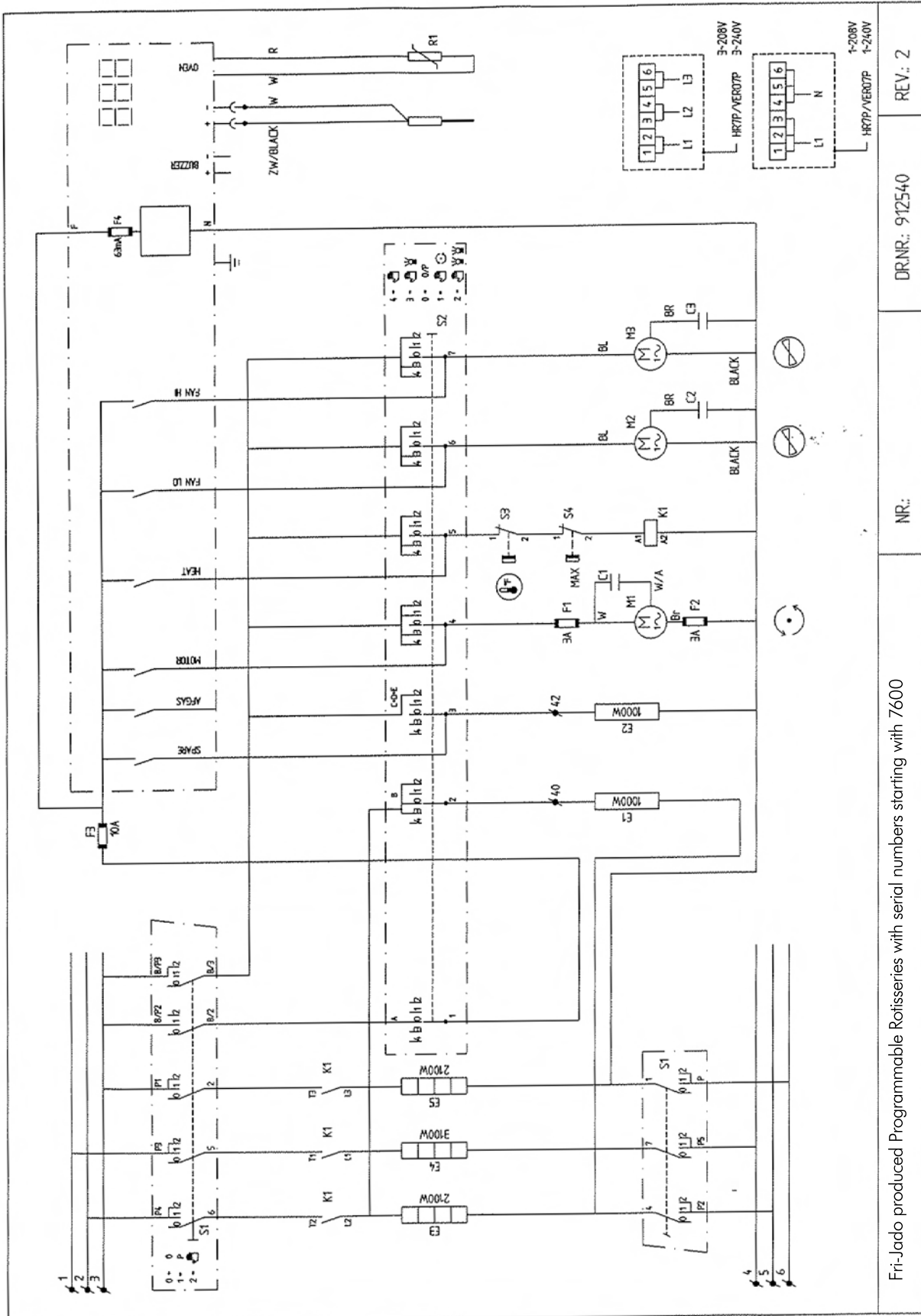

DRNR: 912540      NR:      Fri-Jado produced Programmable Rotisseries with serial numbers starting with 7600      REV.: 2

FJ7500 - CIRCUIT DIAGRAM

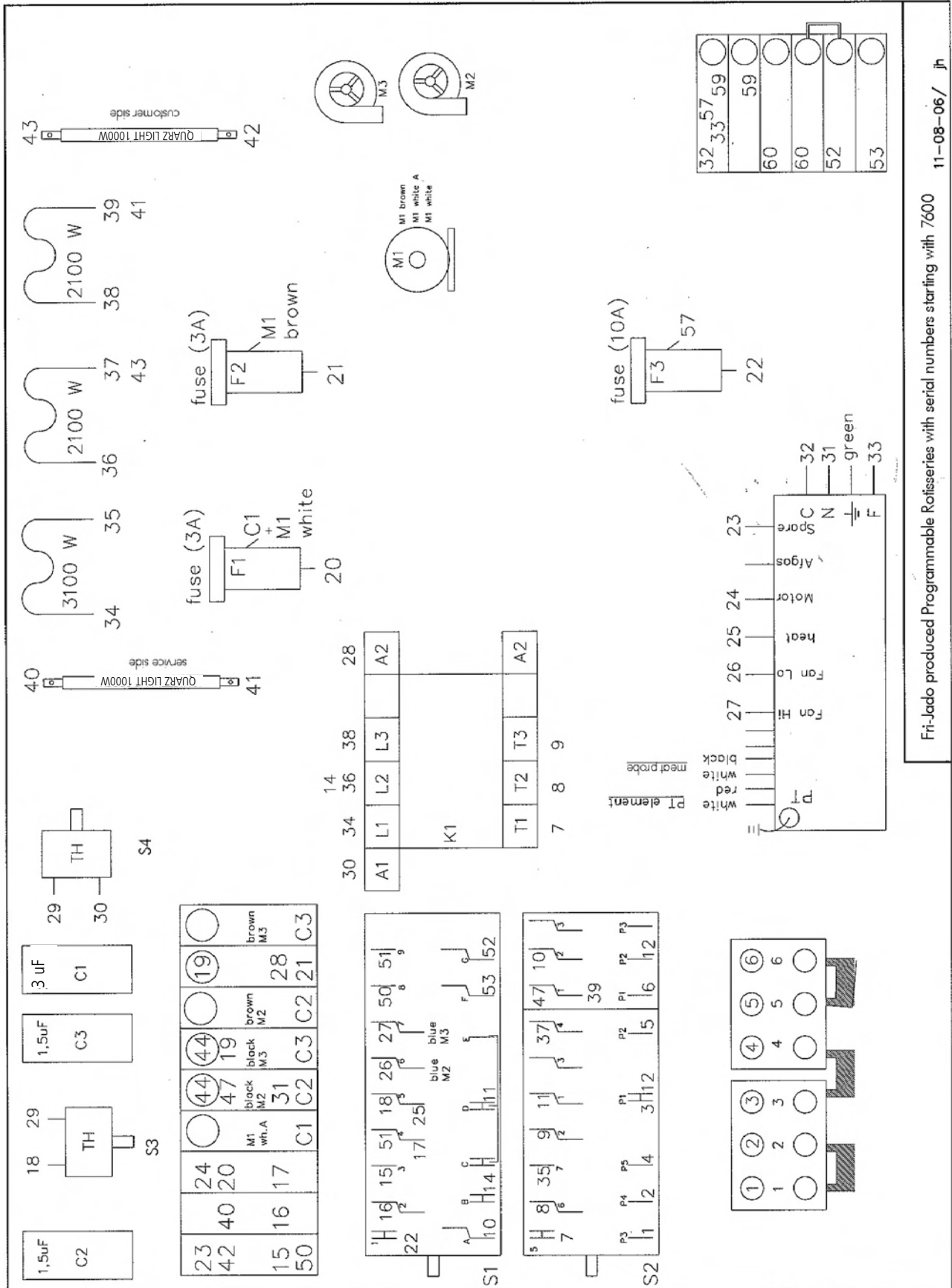

FJ7500 - WIRING DIAGRAM

Fri-Jado produced Programmable Rotisseries with serial numbers starting with 7600 11-08-06/ jh

EMPTY PAGE

EMPTY PAGE

For technical support call:	<b>877 374-5236</b>
For parts call:	<b>877 392-7851</b>