

# 91247091 SERVICE MANUAL Multi Deck Display; MDD-Series US



## - NOTICE -

This service manual is prepared to be used by trained Service Technicians and should not be used by those not properly qualified. If you have attended a training for this product, you may be qualified to perform all repair procedures, replacements and adjustments described in this service manual.

The information presented in this document is only valid for **Multi Deck Display** configurations and is not intended to be all encompassing. The individual specifications may differ.

Procedures for which you do not have the necessary tools, instruments or skills should not be performed by you.

Technical data and specifications mentioned in this manual are subject to amendment without prior notice.

**Reproduction of this service manual,  
without the express written consent of Fri-Jado,  
is prohibited.**

Version	Issue date	Remarks
	dd/mm/yy	
0	01-04-2021	Revision 0 <DRAFT>
1	01-01-2022	First Release
2	July 2022	Change into EU and US version
		Adding 3 level en second version wiring
3	March 2023	Correction on part numbers
4	October 2023	Remark time relay 3 layer, correction part numbers
5	February 2024	Several updates
6	June 2024	1.1 Left en Right Definition merchandisers

© 2024 Fri-Jado B.V., Oud Gastel, The Netherlands.

We refer to our General Terms and Conditions for Sales and Delivery that are available upon request.

The manufacturer does not accept any liability for damage or injury caused by failing to adhere to these regulations or by not observing the usual caution or care in actions, operation, maintenance or repair activities, even if not explicitly described in this manual.

As a result of constant commitment to improvement, it may happen that your unit deviates in detail from what is described in this manual. For this reason, the given instructions are only a guideline for the installation, use, maintenance and repair of the unit referred to in this manual.

This manual has been composed with the utmost care. The manufacturer shall, however, not be held responsible for any mistakes in this manual nor for any consequences thereof. All rights are reserved and nothing in this manual may be reproduced and/or made public in any way.

**Modifications:**

In case of unauthorized modifications in or on the unit, every liability on the part of the manufacturer becomes null and void.

# Index

1.0 Introduction	4
1.1 Introduction Definition of left and right side merchandisers	7
2.0 Detailed description	8
2.1 Connection to main voltage regulations	9
3.0 Unpacking	10
4.0 Installation	11
4.1 Installation of air blockers !!	12
4.2 Installation of front doors 3 level	13
4.3 Installation of front doors 4 - 5 level	20
5.0 Operation	26
5.1 Operation; different controller(s)	27
5.3 Operation <parameter settings>	30
6.0 Maintenance	32
7.0 Trouble shooting	33
8.0 Replacement and adjustment	37
9.0.0 Specifications MDD - 3 Imperial	46
9.0.1 Specifications MDD - 4 Imperial	47
9.0.2 Specifications MDD - 5 Imperial	48
9.1.1 Specifications MDD 24"- 3 Imperial PT - SB	49
9.2.1 Specifications MDD 24"- 4 Imperial PT - SB	50
9.3.1 Specifications MDD 24"- 5 Imperial PT - SB	51
9.4.1 Specifications MDD 36"- 3 Imperial PT - SB	52
9.5.1 Specifications MDD 36"- 4 Imperial PT - SB	53
9.6.1 Specifications MDD 36"- 5 Imperial PT - SB	54
9.7.1 Specifications MDD 48"- 3 Imperial PT - SB	55
9.8.1 Specifications MDD 48"- 4 Imperial PT - SB	56
9.9.1 Specifications MDD 48"- 5 Imperial PT - SB	57
10.0 Exploded view 4 - 5 level	58
10.1 Exploded view 3 level	62
10.2 Exploded view Electrical (first version)	66
10.3 Exploded view Electrical (second version)	68
10.3 Exploded view Electrical (secondversion)	69
11.0 Electrical schematic wiring Multi Temp 4 layer I	70
11.1 Electrical schematic wiring Multi Temp 5 layer I	71
11.2 Electrical schematic circuit Multi Temp I	72
11.3 Electrical schematic wiring Single Temp 4 layer I	73
11.4 Electrical schematic wiring Single Temp 5 layer I	74
11.5 Electrical schematic circuit Single Temp I	75
12.0 Electrical schematic wiring 3 layer single temp II	76
12.0.1 Electrical schematic wiring 3 layer remark concerning Time relay.	77
12.1 Electrical schematic circuit 3 layer single temp II	78
12.2 Electrical schematic circuit Multi Temp 3 layer II	79
12.3 Electrical schematic wiring Multi temp 3 layer II	80
12.4 Electrical schematic wiring Single Temp 4 layer II	81
12.5 Electrical schematic wiring Multi Temp 4 layer II	82
12.6 Electrical schematic wiring Single Temp 5 layer II	83
12.7 Electrical schematic wiring Multi Temp 5 layer II	84
12.8 Electrical schematic wiring Single Temp 4 - 5 layer II	85
12.9 Electrical schematic wiring Multi Temp 4 - 5 layer II	86

# 1.0 Introduction

## 1.1 General

This manual is intended for trained technicians, performing repairs on the Multi Deck Display, MDD. The features and controls are being described, along with directions for the safest and most efficient way to service these counters. All pictograms, symbols and drawings in this manual apply to all available MDD models.

## 1.2 Identification of the unit

The identification plate can be found on the outside of the machine, and contains the following data:

- Name of the supplier or the manufacturer
- Serial number
- Voltage
- Power consumption
- Model
- Year of construction code
- Frequency

## 1.3 Pictograms and symbols

In this manual, the following pictograms and symbols are used:

### WARNING symbols:



**WARNING**  
Possible physical injury or serious damage to the unit,



**WARNING**  
Risk of Fire.



**WARNING**  
Hazardous electrical voltage.



**WARNING**  
Danger of getting injured by hot surfaces.

### SAFETY symbols:



**SAFETY**  
Wear safety gloves for installation and dismantling.



**SAFETY**  
Wear eye protection.



**SAFETY**  
ALWAYS Remove power plug from main outlet before working on the unit.



**Disposal**  
According local regulations



**SAFETY**  
Clean Hands and/or Tools



**Cleaning**  
Not Allowed to use water hose.

### Suggestions and recommendations.



**Notification**  
Take care off.



**Reading**  
Instructions referred to, too be read



**Recycling symbol.**



**Part of manual**  
Still under construction

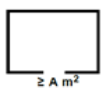

**Minimum room floor area.**



**Pictures or photos**  
Still to be added

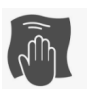

**Cleaning**  
On regularly interval

## 1.0 Introduction

### 1.4.1 Safety rules and regulations

The technician, working on the unit will be fully responsible for abiding the locally prevailing safety rules and regulations.



Technical activities must be performed by qualified and authorized persons only. Before working on any electrical part, or dismantling the unit by means of using a screwdriver or any other tool, **ALWAYS REMOVE THE POWER PLUG** from the main outlet.

Anyone performing technical repairs, replacements or adjustments on or with this unit must be familiar with the contents of this service manual and carefully follow all guidelines and instructions.

Never change the order of the steps to be performed.

The pictograms, labels, instructions and warning signs attached to the unit, are part of the safety measures.



**The pictograms, labels, instructions and warning signs may never be covered or removed,**

and have to be clearly visible during the entire lifetime of the unit.

Immediately repair or replace damaged or illegible pictograms, warnings and instructions.



#### Notes:



- To avoid short-circuiting, never clean the unit using a water hose. *For detailed cleaning instructions, please refer to MDD user manual.*



- The shelves, all glass parts and the back panel of the unit can get hot.



- All units must be cleaned regularly to ensure proper functioning. At least on a weekly basis.



- Do not store explosive substances; such as aerosol cans with flammable propellant, in this appliance.

### 1.4.2 Moving

- Before moving the unit, first switch off the mains switch and disconnect power by pulling the plug from the wall socket.
- Let unit cool down.
- Remove all product from the unit.
- Always keep the unit in upright position.

### 1.4.3 Outdoor use restrictions



#### WARNING

To avoid short-circuiting, the units may not be used outdoors nor in a rainy or very moist environment.

## 1.0 Introduction

### 1.5 Hygiene



#### **WARNING**

Immediately remove products in damaged packaging from the equipment and destroy the products, abiding the locally prevailing safety rules and regulations.



Clean all components that have come in contact with products from damaged packaging.

The quality of a fresh product always depends on hygiene.

It is essential that products are hygienically packaged immediately after preparation, and loaded with a core temperature of 185 °F.



Prevent fresh raw vegetables or already prepared, cooled products from coming into contact with raw meat products to avoid transmitting salmonella.



First thoroughly clean hands and/or tools that have touched raw meat.

*For detailed cleaning instructions, please refer to MDD user manual.*



### 1.6

#### **Service and technical support**

The electrical schematics of the unit are included at the end of this manual.

In case of malfunctions which are not fixable by you, please contact Fri-Jado.

[Service@Frijado.com](mailto:Service@Frijado.com)

Make sure you have the following data available:

- Model.
- Serial number.

This data can be found on the identification plate.

### 1.7

#### **Storage**

If the unit will not be used temporarily, and will be stored, follow these instructions:

- Clean the unit thoroughly.
- Wrap the unit from getting dusty.
- Store the unit in a dry, non-condensing environment.
- Ensure good ventilation.

### 1.8

#### **Disposal**



Dispose of the machine, any components or lubricants removed from it, safely in accordance with all local and national safety and environment rules and requirements.

# 1.1 Introduction Definition of left and right side merchandisers

## Definition of left and right side merchandisers

Within Fri-Jado the definition of the left and right side of merchandisers is determined by looking at the direction in which the products are moving (indicated by the yellow arrow).

### Self-serve counter

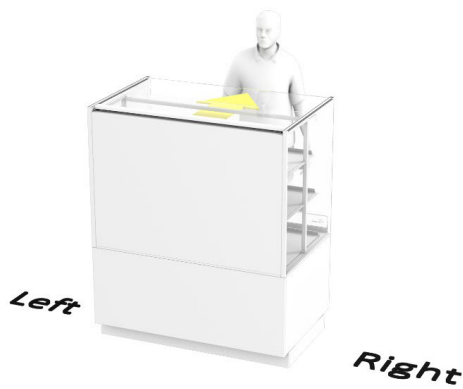

### Serve over counter

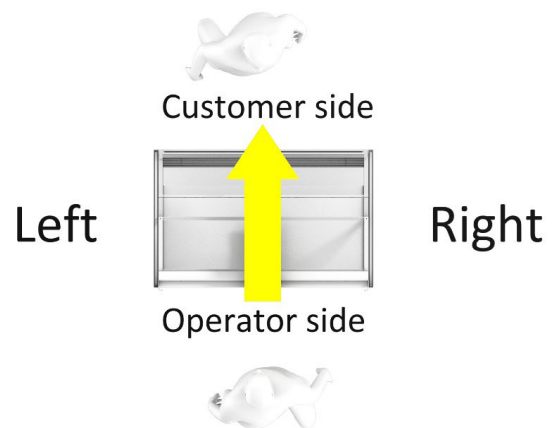
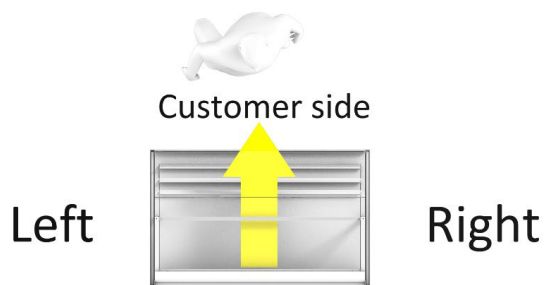
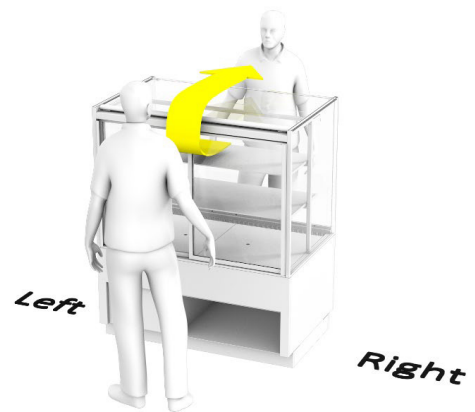

## 2.0 Detailed description

### 2.0 Description

The Multi Deck Display is a multilevel self-service heated display cabinet intended for hot presentation of **packaged** food products.

Each shelf has a self-contained heated air circulation system.

Air is drawn in at the back of the shelf and passed over a heating element located underneath the glass surface.

An air outlet at the front of the shelf creates a stable air curtain at the open side of the cabinet to minimize the infiltration of cold ambient air.



All air in- and outlet openings must be kept clear.

A digital controller is installed to regulate the temperature inside the cabinet.

This can be one single controller for the entire cabinet or one controller per shelf, (Also called multi-temp configuration) which allows individual shelves to be controlled independently of one another.



To make sure the cabinet is installed, operated and serviced in a safe manner, the instructions provided by Fri-Jado and stated in this service manual should be adhered to at all times.

MDD cabinets can be ordered with a pass-through option (utilizing rear folding doors) or with a solid back.

The MDD is ETL listed (conforms to UL standard 197, NSF standard 4 and CSA standard C22.2 no. 109).



The information presented in this document is valid for standard MDD- configurations, specifications for custom configurations may differ.

No rights can be derived from this document. Specifications and technical data are subject to amendment without prior notice.

## 2.0 Detailed description

### 2.1 Connection to main voltage regulations

#### Connection to main voltage.



**Warning** Electrical shock Hazard

- **Grounding instructions:**



Only connect the appliance

- > on: an alternating current.
- > on: a grounded wall socket.
- > with a mains voltage in accordance with the information indicated on the type plate of the appliance.



- It is the consumer's responsibility to make sure the electrical installation conforms with current national and local codes and wiring regulations

- It is not allowed to use a multi plug or extension cord.



Such can result in fire, electrical shock, or personal injury.

Failure to follow these instructions can result in serious injury or even death.

## 3.0 Unpacking

UNPACKING INSTRUCTION MDD

9124672 rev. 05/2020

1

All packing materials used for this unit are suited for recycling.



Before and during unpacking, check the state of the unit. In case of damage, store the packing material, and contact the transporter within fifteen working days after receiving the goods.

2

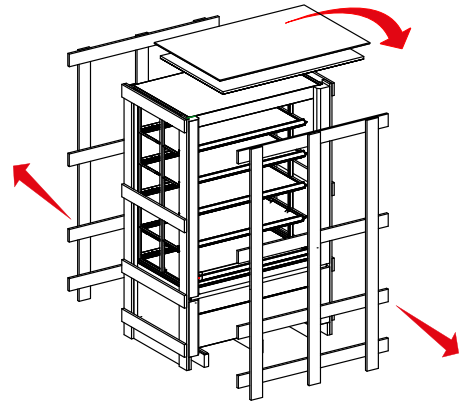

Remove the top crate pane and foam.

3

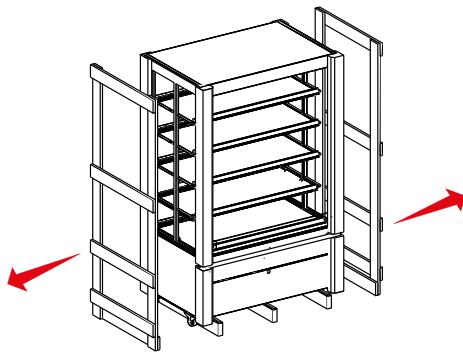

Remove the 2 side boards.

4

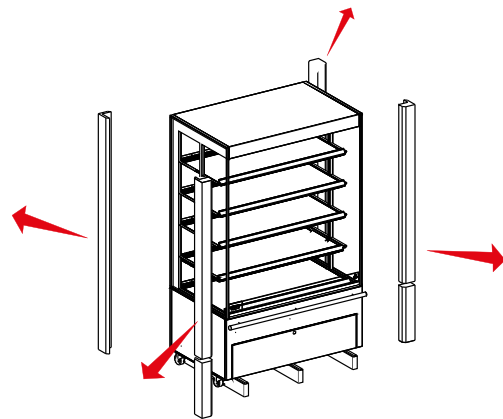

Remove tempex and foil.

5

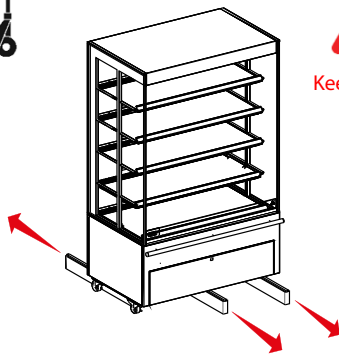

Lift the unit from the support beams using a pallet truck or forklift.

Remove the supporting beams.



Keep castors locked!

6

NL - Lees de handleiding voordat u verder gaat.  
 EN - Read the manual before proceeding.  
 DE - Lesen Sie die Gebrachsanleitung, bevor Sie Fortfahren.  
 FR - Lire le manuel avan de continuer  
 ES - Leer el manual antes de continuar  
 PT - Leia o manual de instruções antes de continuar.  
 IT - Leggere il manuale prima di procedere.  
 NO - Les nøye gjennom instruksjonene før du tar apparatet i bruk.  
 SV - Läs igenom bruksanvisningen innan du fortsätter.  
 FI - Lue käyttöohje ennen kuin otat laitteen käyttöön.



## 4.0 Installation

### 4.0 Placement of the unit

#### WARNING



Position the unit on a flat and horizontal surface.  
A temporarily inclined plane of maximum 5° is allowed.

- Be sure that the personnel have sufficient room to work with the unit.
- Keep a distance of at least 6 inch between the wall and the back of the unit.
- While positioning, keep the unit out of children's reach.
- Do not position a unit near a doorway, a ventilation device or a refrigerator in order to avoid any negative effects on the unit's operation by a cold airflow.  
The unit is designed for a maximum draft of 0.2 m/s (0.65 ft./sec).
- Do not place into direct sunlight.
- The unit should not be used below 68 °F ambient temperatures.
- The unit has a mains plug, and must be connected to a wall socket with the proper mains voltage.  
The wall outlet must be installed by a certified electrician.

*For detailed specifications see chapter 9*

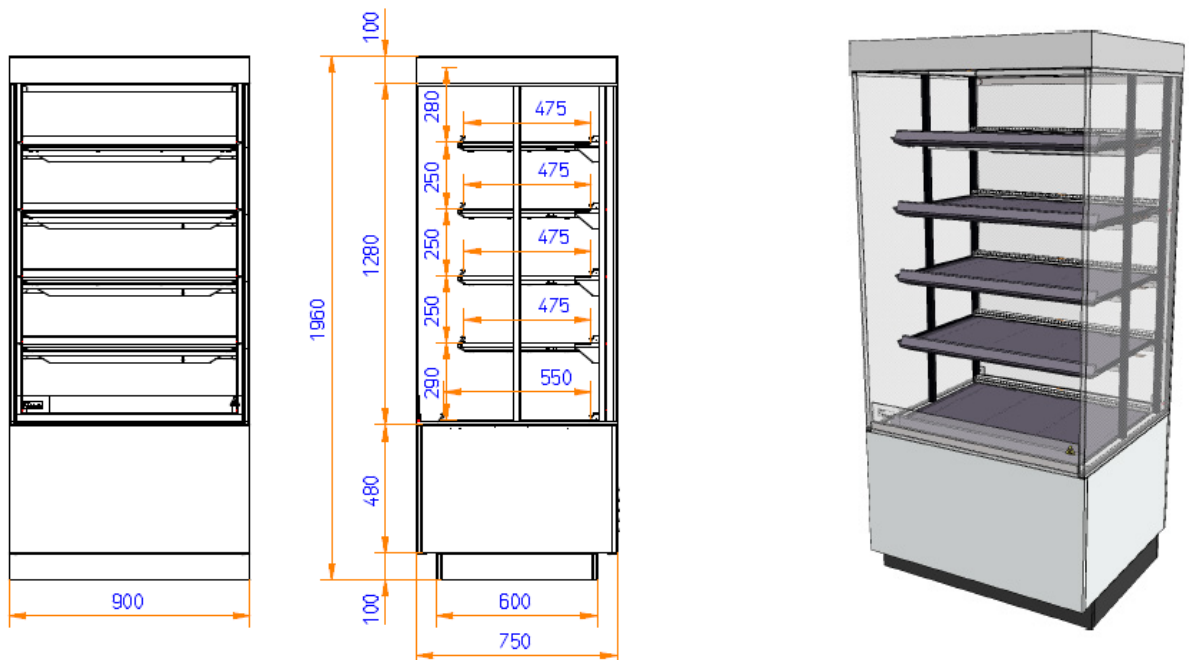

### 4.1 Air blockers !!

**Last step of installation is the installation of the air blockers on each shelf.**



**Without the air blockers in position,  
the performance of the MDD can not be guaranteed.**

## 4.1 Installation of air blockers !!

INSTALL INSTRUCTION AIRBLOCKERS MDD

9124609 rev. 10/2021

1

Without the airblockers the performance of the MDD **cannot** be guaranteed!

The airblockers have the following numbers:

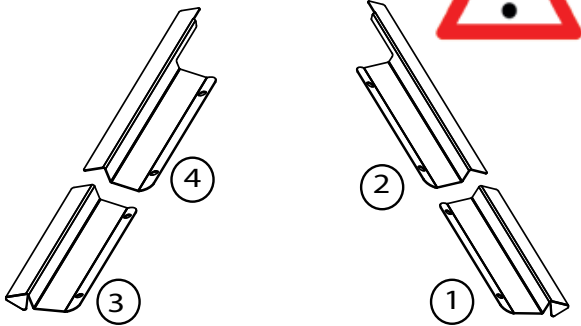

2

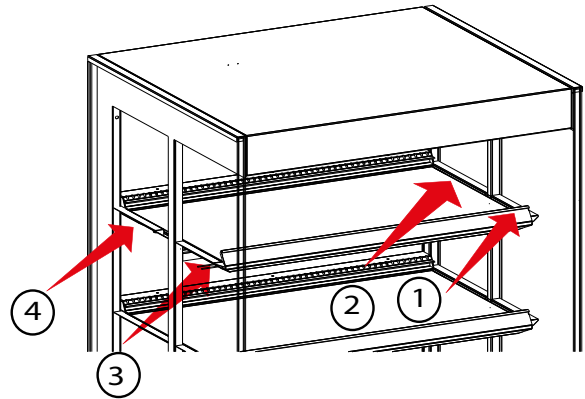

Mount the airblockers under the shelves.

3

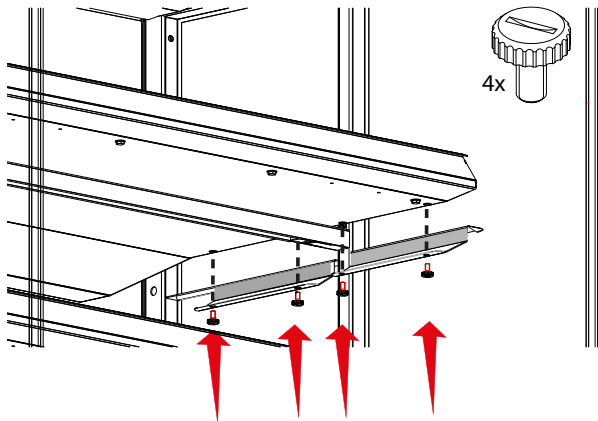

Mount airblocker 1 & 2 on the right hand side of the shelf with 4 screws (hand tight).

4

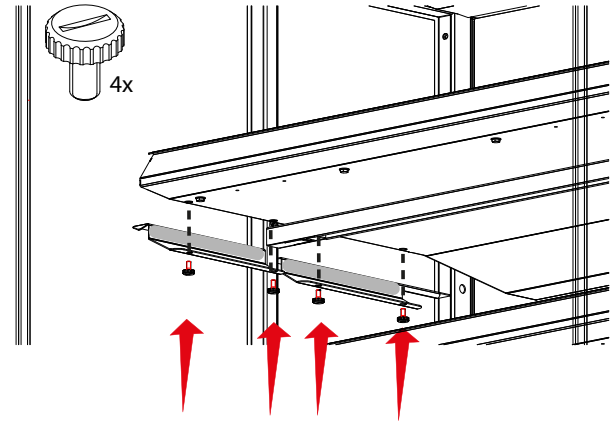

Repeat step 3 with airblocker 3 & 4 on the left side of the shelf.

5

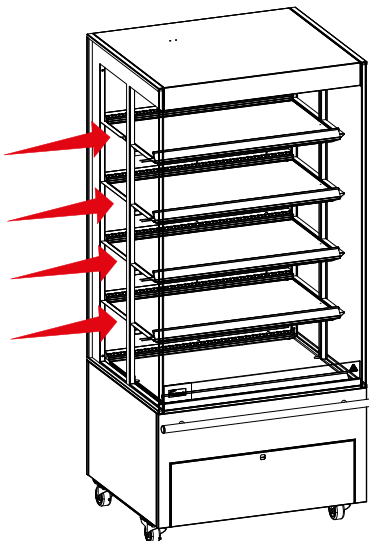

Repeat step 3 & 4 for all shelves.

6

EN - Read the manual before proceeding.  
 NL - Lees de handleiding voordat u verder gaat.  
 DE - Lesen Sie die Gebrachsanleitung, bevor Sie Fortfahren.  
 FR - Lire le manuel avan de continuer.  
 ES - Leer el manual antes de continuar.  
 PT - Leia o manual de instruções antes de continuar.  
 IT - Leggere il manuale prima di procedere.  
 NO - Les nøye gjennom instruksjonene før du tar apparatet i bruk.  
 SV - Läs igenom bruksanvisningen innan du fortsätter.  
 FI - Lue käyttöohje ennen kuin otat laitteen käyttöön.



## 4.2 Installation of front doors 3 level

### 9124722 Service Instruction Installation front doors MDD-3 level

The technician, working on the unit will be fully responsible for abiding the locally prevailing safety rules and regulations.

Technical activities must be performed by qualified and authorized persons only.

Before working on any electrical part, or dismantling the unit by means of using a screwdriver or any other tool, **ALWAYS REMOVE THE POWER PLUG** from the main outlet.



## 4.2 Installation of front doors 3 level

	Door set
MDD-3 60	9380369
MDD-3 90	9380370
MDD-3 120	9380372



## 4.2 Installation of front doors 3 level

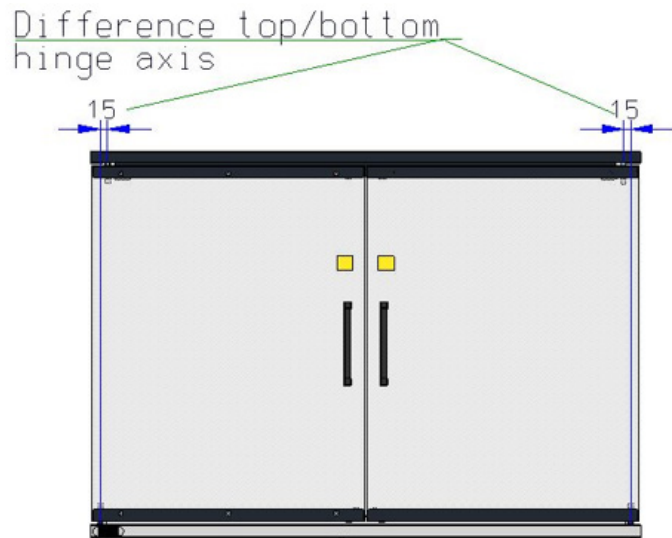
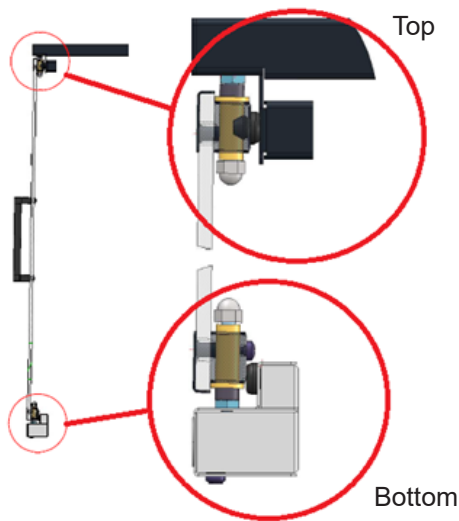

Depending on variant:

With standard under frame:

Remove front under frame panel (two screws, one on each bottom corner).

Drop-In:

Raise the unit at least 30cm from tabletop level in order to access the screws for the child guard.  
Be careful to support the unit such that no components or connections underneath the base of the unit are damaged while doing so.

### Step 1.

#### Remove Child guard:

*Refer service manual chapter replacement and adjustment*

- a. Remove front panel.
- b. Loosen mounting screws (3x depending on unit length) of child guard. *Screwed from underneath.*
- c. Remove child guard
- d. Position under beam on place of child guard
- e. Fasten mounting screws.



## 4.2 Installation of front doors 3 level

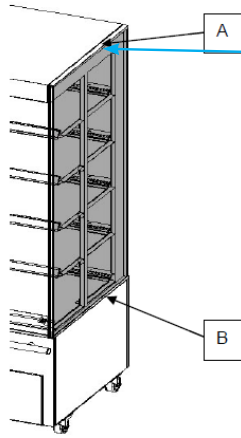
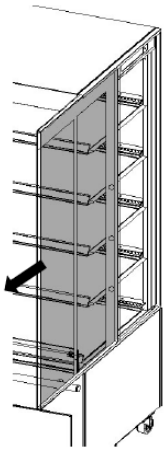

### Step 2.

- a. **Remove side glass** both sides:
- b. Slide the double glass pane towards the front along the top (A) and bottom (B) guiding rails.
- c. The side pane can be removed from the unit once it has slid entirely past the top guide.



### CAUTION:

Once past the top guide, the glass pane might fall if not properly held. Hence do not leave it standing upright without being supported by both guide rails or holding it.

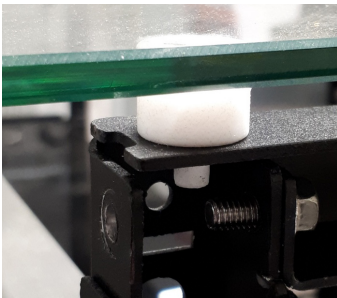

HOT

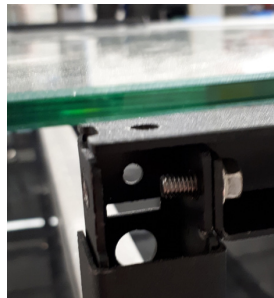

COLD

### Step 3.

- a. **Remove white (or black) stud**, both sides. *(Black stud is screwed in)*

### Step 4.

- a. **Remove top air guide.**

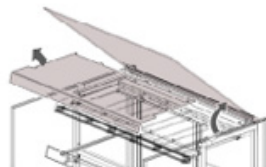

### Step 5.

- a. **Remove side glass holder**, left and right.



## 4.2 Installation of front doors 3 level



### Step 6.

- a. **Remove top column cover** by removing last screw. (one each side)

### Step 7.

- a. **Place new (longer) top column cover(s)/ window support** (two screws).
- b. Mount screws in new top column cover



### Step 8.

- a. **Replace white (or black) stud** removed earlier.



### Step 9.

- a. **Replace side glass holder** removed earlier.

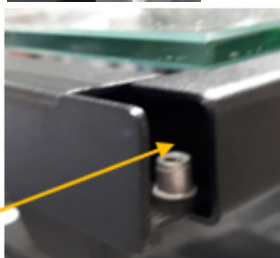

### Step 10.

- a. **Place top front beam** in side profiles.  
Slide the beam into the front of the profile.



### Step 11.

- a. **Fasten the top front beam** in side profiles with screws. (both sides)

View from underneath

## 4.2 Installation of front doors 3 level

Bottom Side

### Step 12.

- a. **Check placing bearing(s)** in door(s), one in the top, one at the bottom.

Make sure the flange of the bearing sits opposite of the glass.

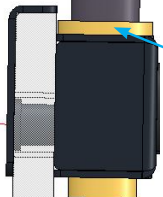

Flange

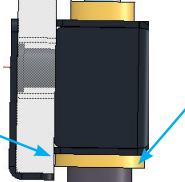

TOP Side



### Step 13.

- a. Place a door on the lower beam, let it stick out of the unit.



#### CAUTION:

Be careful not to touch the top beam with the glass door.

### Step 14.

- a. Place hinge pin into bearing

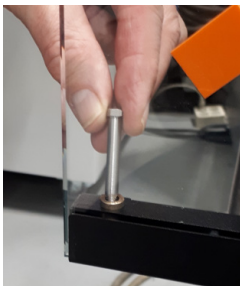

### Step 15.

- a. Place distance ring on hinge pin.

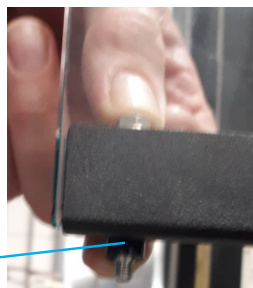
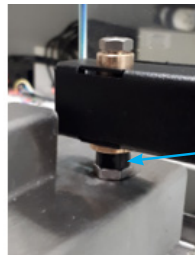
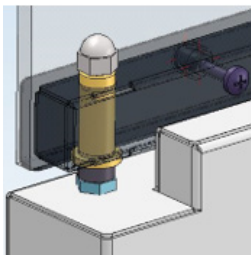

### Step 16.

- a. Fasten hinge pin loosely, making sure the door is kept in place

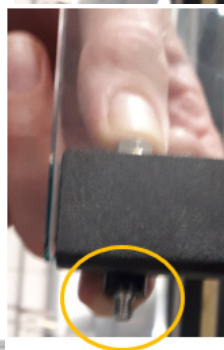

## 4.2 Installation of front doors 3 level

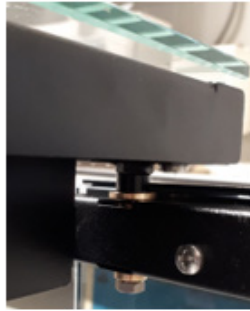
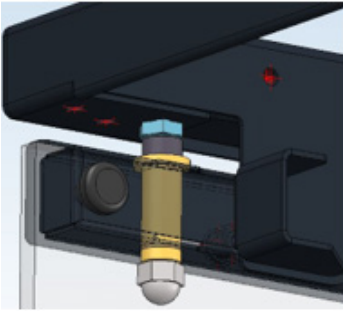

### Step 17.

- a. Place top hinge pin into top bearing.
- b. Place distance ring on top hinge pin.
- c. Fasten top hinge pin, tighten tight !

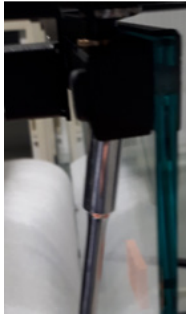

### Step 18.

- a. Fasten lower hinge pin, tighten tight !

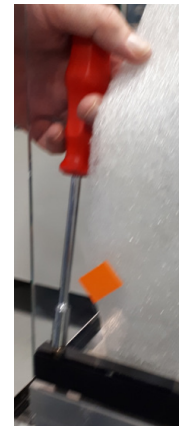

### Step 19.

- a. Repeat step 14 till 19 for each front door, depending on MDD variation.
- b. Replace top air guide.

## 4.3 Installation of front doors 4 - 5 level

### 9124723 Service Instruction Installation front doors MDD 4-5 Level

The technician, working on the unit will be fully responsible for abiding the locally prevailing safety rules and regulations.

Technical activities must be performed by qualified and authorized persons only.

Before working on any electrical part, or dismantling the unit by means of using a screwdriver or any other tool,

**ALWAYS REMOVE THE POWER PLUG** from the main outlet.



## 4.3 Installation of front doors 4 - 5 level



Version	Door set	Version	Door set
MDD-60-4	9398010	MDD-60-5	9398013
MDD-90-4	9398011	MDD-90-5	9398014
MDD-120-4	9398012	MDD-120-5	9398015

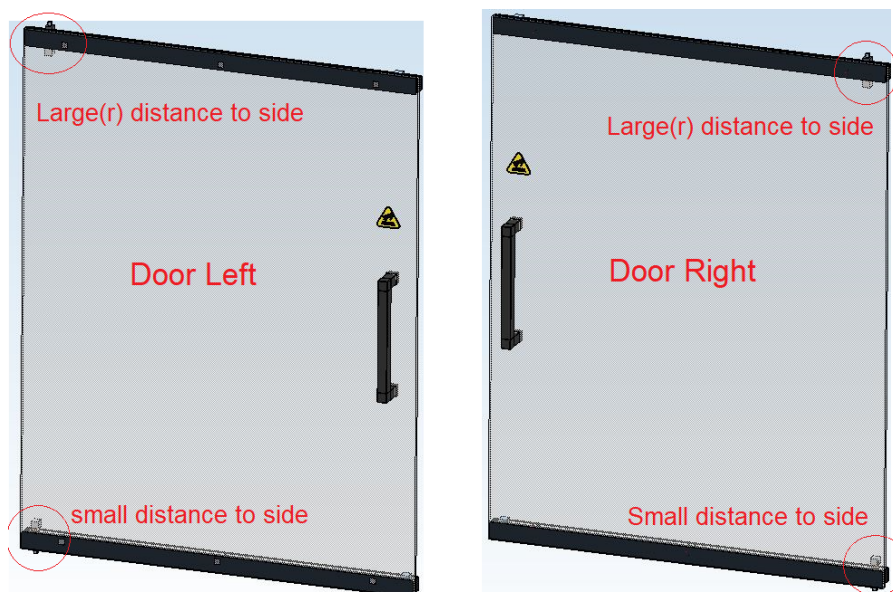

## 4.3 Installation of front doors 4 - 5 level

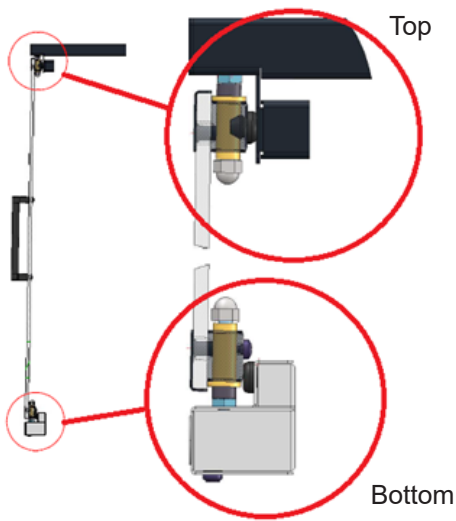

Difference top/bottom  
hinge axis



### Step 1.

#### Remove Child guard:

*Refer service manual chapter replacement and adjustment.*

- a. Remove front panel.
- b. Loosen mounting screws of child guard. (3x depending on unit length) *Screwed from underneath.*
- c. Remove Child guard.
- d. Position under beam on place of child guard.
- e. Fasten mounting screws.



## 4.3 Installation of front doors 4 - 5 level

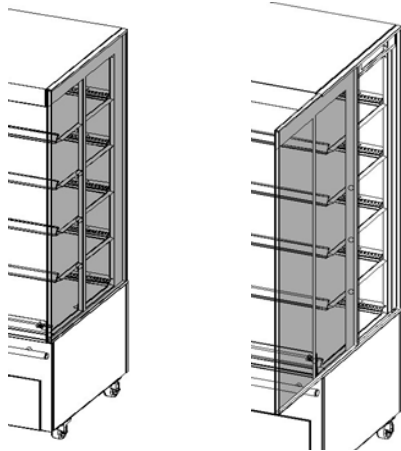

### Step 2.

- a. **Remove side glass:**  
(MDD-60 hinge side only):  
(MDD-90 and MDD-120 both sides):
- b. Slide the double glass pane towards the front along the guiding rails.
- c. The side pane can be removed from the unit once it has slid entirely past the guiding rails.



### CAUTION:

Once past the guide rails, the glass pane might fall if not properly held. Do not leave it standing upright without being supported or holding it.

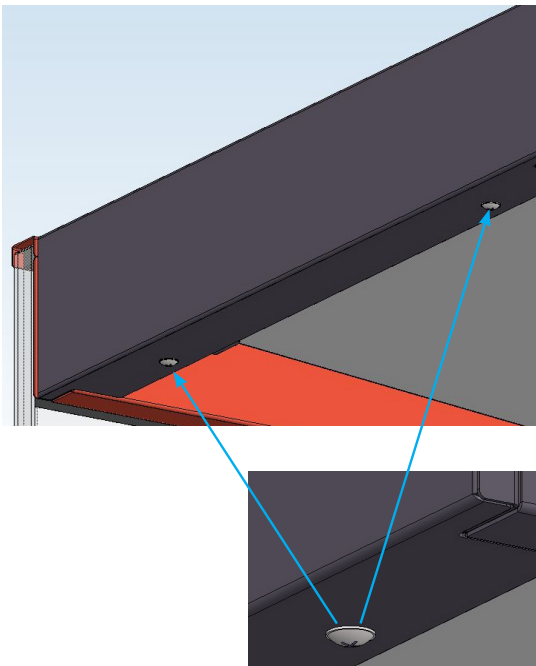

### Step 3.

- a. **Remove screw(s):**  
from top panel.
- Leave top panel in position.

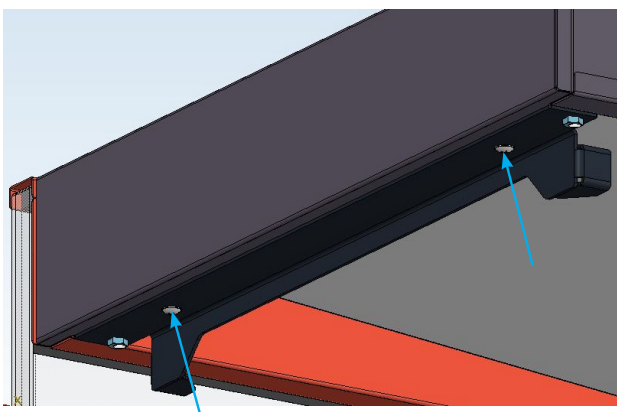

### Step 4.

- a. **Place top front beam,**  
use mounting holes from previously removed screws from top panel.
- Use the screws removed earlier.

## 4.3 Installation of front doors 4 - 5 level

### Step 5.

- a. **Check placing bearing(s):**  
in the door(s),  
one in the top,  
one at the bottom.

Make sure the flange of the bearing sits opposite of the glass.

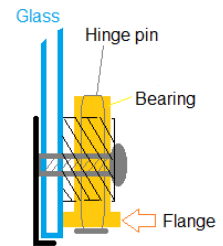
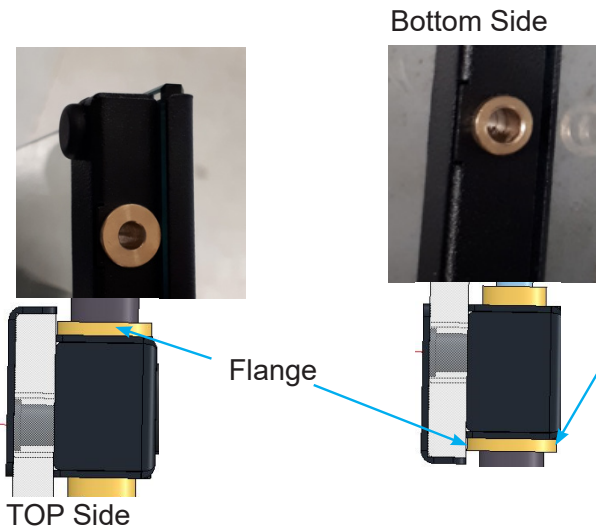

### Step 6.

- a. Place hinge pin into bearing.

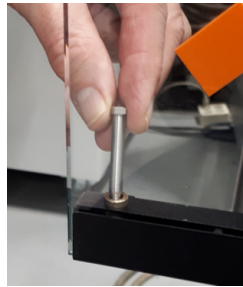

### Step 7.

- a. Place distance ring on hinge pin.

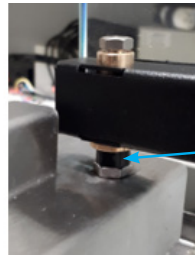
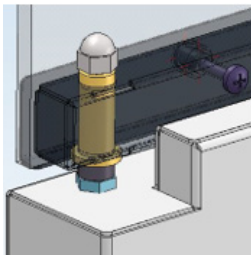

### Step 8.

- a. Fasten hinge pin loosely, making sure the door is kept in position.

Do not loose the distance ring.

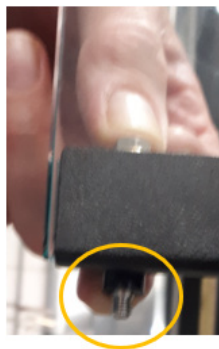

## 4.3 Installation of front doors 4 - 5 level

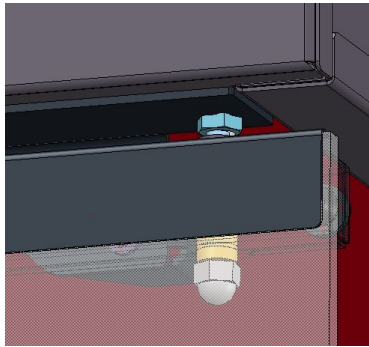

### Step 18.

- a. Place top hinge pin into top bearing.
- b. Place distance ring on top hinge pin.
- c. Fasten top hinge pin, tighten tight !

### Step 19.

- a. Fasten lower hinge pin, tighten tight !



### Step 20.

- a. Repeat step 14 till 19 for each front door, depending on MDD variation.

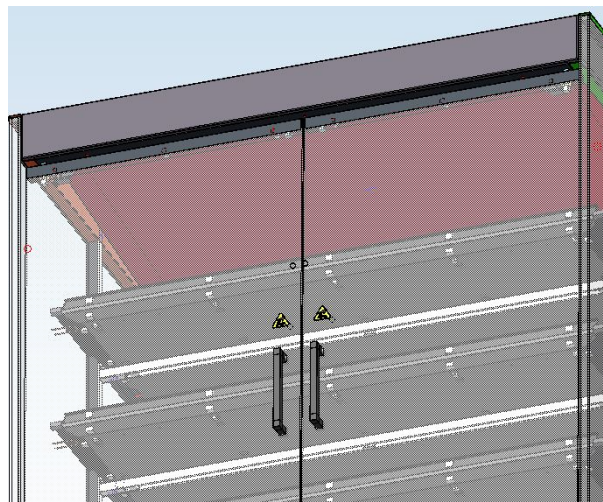

### Top Mounting

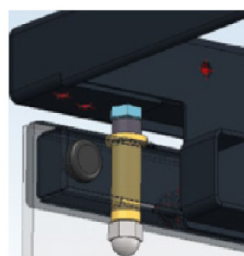
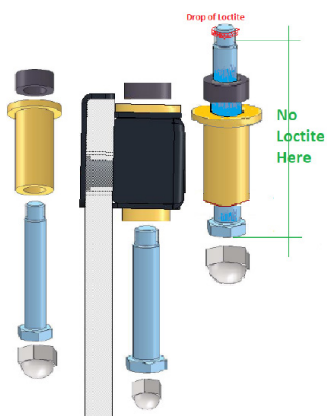

**Result**

### Bottom Mounting

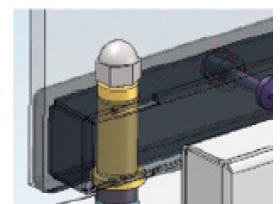
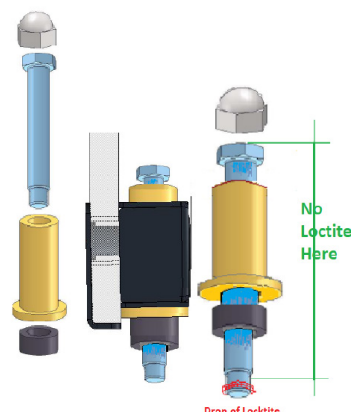

**Result**

## 5.0 Operation

### 5.0.0 Settings



**The display value is not the product temperature!**

When switched on, the display performs a lamp test; the display and LED's will flash for several seconds to check all functions are working correctly.

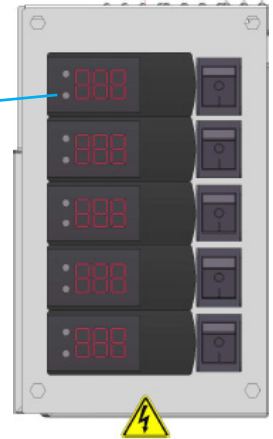

### Temperature controller

- ⏻ Power on/off button\*
- ⬆ UP-button
- ⬇ DOWN-button
- SET ← SET-button



Image for reference only.

\* Switch on/off: hold for several sec.

## 5.1 Operation; different controller(s)

### Service Instruction Controller replacement

Due to supply issues, Fri-Jado uses different kind of controllers as placed in our units from factory.

Four possible controllers are used.

For Service replacements we only deliver Eliwell ICPlus 902

Please find below the difference in connections and parameters.

For disassembly instructions refer to the original service manual for the unit at hand.

**Service  
Replacement-  
unit,  
(UL certified)**

**Eliwell ICPlus 902**  
9281071 (programmed)  
9381056 (unprogrammed)



We use four different types of controllers:

**Eliwell ICPlus902**

**Eliwell IDNext 961**  
9381054



**Eliwell ID Next 961**

**ERC 211**  
9221109



**Danfoss ERC211**

**VDH Alfa 31**  
9381055



**VDH Alfa 31**

## 5.1 Operation; different controller(s)



Eliwell ICPlus 902  
9281071 (programmed)  
9381056 (unprogrammed)



ICPlus 902 (NTC/PTC - 15A (24Vac, 230Vac))

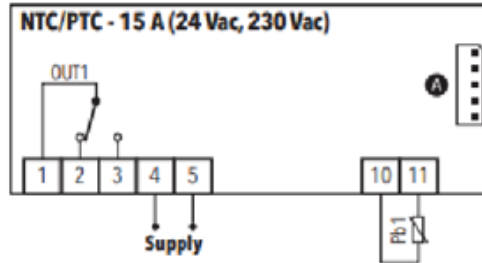

4
5
1
3
10
11

ERC 211  
9221109



4.4.1| ERC 211 - connection diagram

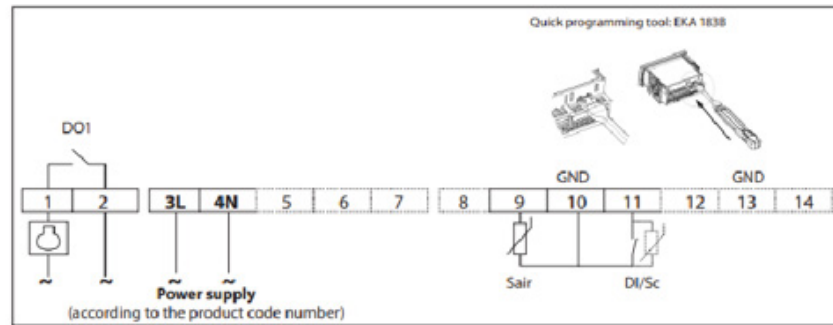

3L
4N
2
1
9
10

Eliwell IDNext 961 IDNext 961 P (230 Vac)  
9381054

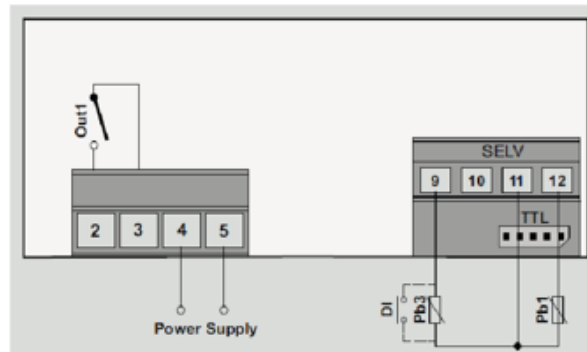

4
5
3
2
11
12

## 5.1 Operation; different controller(s)

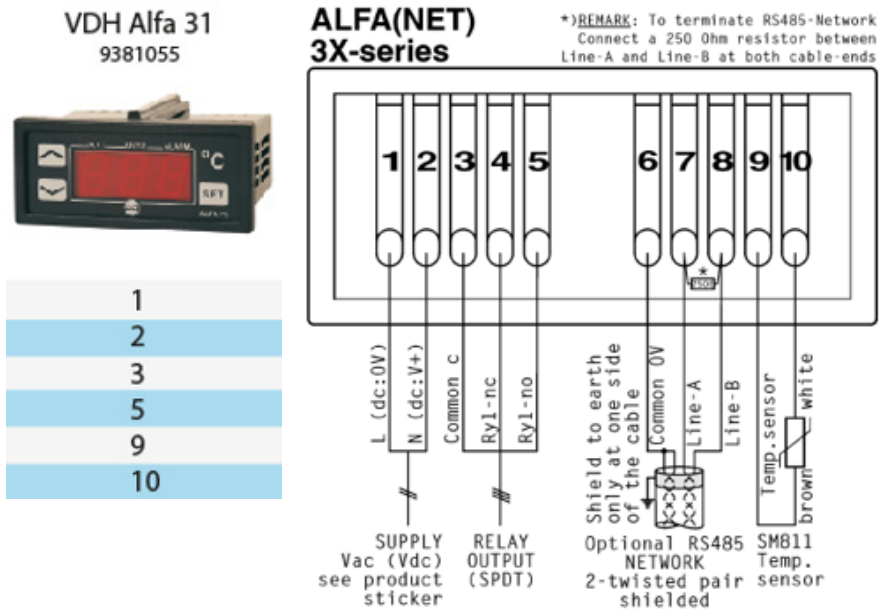

### Difference in connections between the four controllers

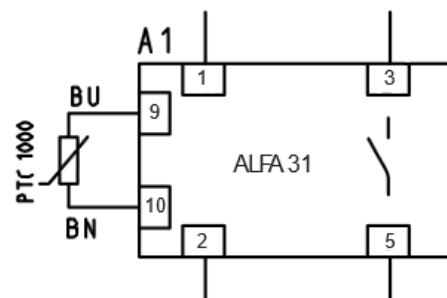
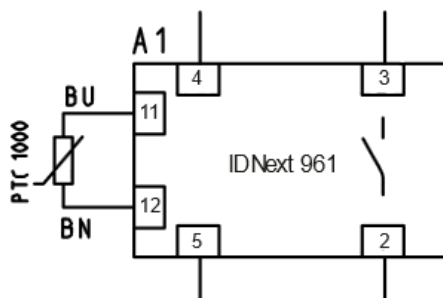
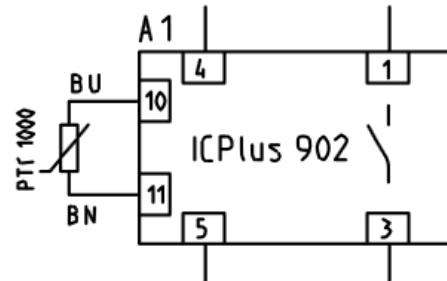
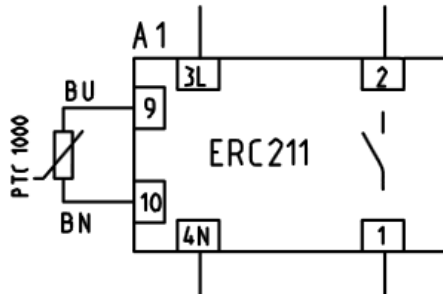

## 5.3 Operation <parameter settings>

<u>Doc. nr.</u> 9124410	<u>Rev.</u> C	Registration fom. <b>Settings – 65 °C</b>	
----------------------------	------------------	--	---

MCC Hot SS	
MDD	

### Controller: Eliwell ICPlus 902

**Note:** Use tool **STICK 18** for inserting parameters and only change **orange arced parameters** manually!

Below the parameters that are changed from the default settings:

User parameters:

SP1	Temperature set point	<u>65</u>	°C
df1	Differential	<u>1</u>	K
HS1	Max set point limitation	<u>70</u>	°C
LS1	Min set point limitation	<u>40</u>	°C
LoC	Keypad lock n(0)=lock disabled y(1)=lock enabled	<u>n</u>	
ndt	Display with decimal point, n(0)=no y(1)=yes	<u>y</u>	
CA1	Display offset	<u>0</u>	°C
H00	Sensor type, 0 = ptc, 1 = ntc, 2 = pt1000	<u>0</u>	

Installer parameters:

rE1	HC1	Cold "C(0)" or hot "H(1)" operation	<u>H</u>	
	HA1	Max temp alarm	<u>100</u>	°C
CnF	dro	Unit of measurement (0=C 1 =F)	<u>0</u>	

## 5.3 Operation <parameter settings>

Doc. nr. <b>9124724</b>	Rev. <b>A</b>	Registration form. <b>Settings – 65 °C</b>	
----------------------------	------------------	---	---

MDD 60 ST	

### Controller: Eliwell ICPlus 902

**Note:** Use tool **STICK 18** for inserting parameters and only change **orange arced parameters** manually!

Below the parameters that are changed from the default settings:

User parameters:

SP1	Temperature set point	<b>65</b>	°C
df1	Differential	<b>1</b>	K
HS1	Max set point limitation	<b>70</b>	°C
LS1	Min set point limitation	<b>40</b>	°C
LoC	Keypad lock n(0)=lock disabled y(1)=lock enabled	<b>n</b>	
ndt	Display with decimal point, n(0)=no y(1)=yes	<b>y</b>	
CA1	Display offset	<b>-5</b>	°C
H00	Sensor type, 0 = ptc, 1 = ntc, 2 = pt1000	<b>0</b>	

Installer parameters:

rE1	HC1	Cold "C(0)" or hot "H(1)" operation	<b>H</b>	
	HA1	Max temp alarm	<b>100</b>	°C
CnF	dro	Unit of measurement (0=C 1 =F)	<b>1</b>	

## 6.0 Maintenance

### 6.0 CLEANING AND MAINTENANCE



**WARNING**

Never use a water hose for cleaning.  
Water can seep into the unit through the ventilation holes of the unit.



Because of hygiene aspects and optimum condition of the unit it is of utmost importance to keep a daily cleaning pattern from first use onwards.

**Maintenance schedule for users**

Item	Action	Frequency
Inside	Clean	Daily
Glass Panes	Clean	Daily
Outside	Clean Use e.g. mild detergent or cleaning spray to remove stains, and restoring the gloss.	Weekly



*For detailed cleaning instructions refer to User manual.*

### 6.1 Cleaning Shelf(s)



- Remove products from shelf.
- Switch off unit, and let cool down.
- Clean shelf glass with moist cloth, using a mild detergent only.

## 7.0 Trouble shooting

### 7.0 Problems which can be checked by user



Each user can check the following points as mentioned in the user manual:

- Is the power supply ok?
- Check the fuses and the earth leakage circuit breaker in the meter cupboard.
- Are all the switches in the correct “on” position?

Item	Malfunction	Possible action
Unit	Unit does not work	<ul style="list-style-type: none"> <li>• Check the power supply.</li> <li>• Check the earth leakage circuit breaker.</li> <li>• Are all switches in the correct position.</li> </ul>
Unit	Display shows error code	<ul style="list-style-type: none"> <li>• Contact your supplier or service agency.</li> </ul>
Lamp	Does not light up	<ul style="list-style-type: none"> <li>• Switch ON.</li> </ul>
Mains cord	Damaged	<ul style="list-style-type: none"> <li>• Replace.</li> </ul>
Window	Damaged	<ul style="list-style-type: none"> <li>• Replace.</li> </ul>

### 7.1 Replace the mains cord



#### WARNING

Hazardous electrical voltage.



If the mains cord is damaged, it must be replaced by a fully certified and qualified person in order to avoid hazards.

### 7.2 Heating element testing



#### Resistance

1. Remove wiring (two) from the element.
2. Connect a probe of the multimeter to each of the contact points of the element.
3. Test the probe with a Ohm tester, values see below.



#### Current

1. Place ampere pliers around red wire of Element.
2. In normal working condition, test current see below. (230V version)

Shelf	MDD60			MDD90			MDD120		
	Power	Current	Resistance	Power	Current	Resistance	Power	Current	Resistance
	Watt	Ampere	Ohm	Watt	Ampere	Ohm	Watt	Ampere	Ohm
Top	465	2,02	113,7	700	3,04	75,6	935	4,07	56,6
Shelf 1	570	2,48	92,8	850	3,70	62,2	1130	4,91	46,8
Shelf 2	570	2.48	92,8	850	3,70	62,6	1130	4,91	46,8
Shelf 3	570	2.48	92,8	850	3,70	62,6	1130	4.91	46,8
Bottom	750	3,26	70,5	1125	4,89	47,0	1500	6,52	35,3

## 7.0 Trouble shooting

### 7.3 PTC1000 sensor testing (Each shelf has own PTC1000 sensor)



1. Remove sensor wiring from the connector block.
2. Connect a temperature tester to the probe of the sensor for comparison.
3. Test the sensor wires with a Ohm tester.

Temperature		Resistance $\Omega$
$^{\circ}F$	$^{\circ}C$	+/- 5 Ohms
-4	-20	677
14	-10	740
32	0	807
50	10	877
68	20	951
77	25	990

Symptom	Possible causes
No power	<ol style="list-style-type: none"> <li>1. Main circuit breaker open</li> <li>2. Earth leakage circuit breaker tripped</li> <li>3. Fuse Blown</li> <li>4. Loose wire connection</li> <li>5. Wiring incorrectly</li> <li>6. Short circuit heating element</li> <li>7. Short circuit fan</li> <li>8. Short circuit wiring</li> </ol>
Illumination does not work	<ol style="list-style-type: none"> <li>1. Led malfunction</li> <li>2. Tumble switch malfunction</li> <li>3. Led driver malfunction</li> <li>4. Loose / short circuit / wiring connection</li> </ol>
No heating	<ol style="list-style-type: none"> <li>1. Heating element malfunction</li> <li>2. Relay malfunction</li> <li>3. Loose wiring connection</li> <li>4. Thermostat malfunction</li> <li>5. Air flow blocked</li> <li>6. PTC sensor malfunction</li> </ol>
Unit does not reach desired temperature	<ol style="list-style-type: none"> <li>1. Heating element malfunction</li> <li>2. Strong air current along unit / Draft</li> <li>3. Burned contact on contactor</li> <li>4. Sensor malfunction</li> <li>5. Doors not closed (if available)</li> </ol>
No indication on controller	<ol style="list-style-type: none"> <li>1. Electronic controller malfunction</li> <li>2. Blown fuse</li> <li>3. Loose wiring connection</li> </ol>
No air flow inside unit	<ol style="list-style-type: none"> <li>1. Fans do not work</li> <li>2. Blown fuse</li> <li>3. Loose wiring connection</li> <li>4. 24 Vdc power supply malfunction</li> </ol>

## 7.0 Trouble shooting

Description of part	Symptoms	Possible causes	Solution / Check / Action
Contactor	Contactor does not work	Wiring Coil malfunction Contact burned	Check wiring Check resistance of coil +/- 525Ω Check the contacts Replace contactor
Heating element	Unit is not reaching the set temperature	Wiring Element malfunction  No Air flow. Fan's not turning	Check wiring Check power on elements per shelf Check current with AC current tester (refer 7.3) Check Resistance (refer 7.3) Replace element Check wiring Check power on fans per shelf Replace fan box/Power Supply
Tumble switch	Unit, Light or heating does not switch on	Wiring Contact burned	Check wiring Check the voltage on "in" and "output"
LED	Light does not turn on	Wiring LED broken LED driver defect	Check Wiring Replace LED Replace LED driver
Electronic thermostat	Display does not light up  The unit is not reaching the set temperature	Wiring  Loose sensor Thermostat Malfunction Thermostat setting	Check wiring  Check sensor Replace thermostat Check parameters
PTC 1000 sensor	The unit is not reaching the set temperature or does not heat up at all  The unit becomes too hot	Loose sensor Broken Sensor	Check Resistance (refer 7.4) Check sensor wiring Replace sensor

## 7.0 Trouble shooting

### 7.4 Alarms

#### Alarm Code

Alarm status	Alarm Code
Air temperature sensor (Sair) error	E29
Defrost sensor (S5) error	E27
Condenser sensor (Sc) error	E30
High temperature alarm	A01
Low temperature alarm	A02
High voltage alarm	A99
Low voltage alarm	AA1
High condenser temperature alarm	A61
Door alarm	A04
Standby alarm	A45
DI external alarm	A15

#### Solutions

ALARM CODE	POSSIBLE SOLUTION
E29	Not applicable for MDD
E27	Not applicable for MDD
E30	Not applicable for MDD
A01	Heating element malfunction / sensor error
A02	Heating element malfunction / sensor error
A99	Power supply error
AA1	Power supply error
A61	Not applicable for MDD
A04	Not applicable for MDD
A45	Controller error
A15	Sensor error

- Alarm Reset - Power controller OFF and power ON controller again.  
 - Switch controller OFF and ON again via main switch or front button.

## 8.0 Replacement and adjustment

### 8.0. Side glass replacement:



The side glass pane of the units can easily be removed.

1. Slide the double glass pane towards the front along the top and bottom guiding rails.  
The side pane can be removed from the unit once it has slid entirely out of the unit.

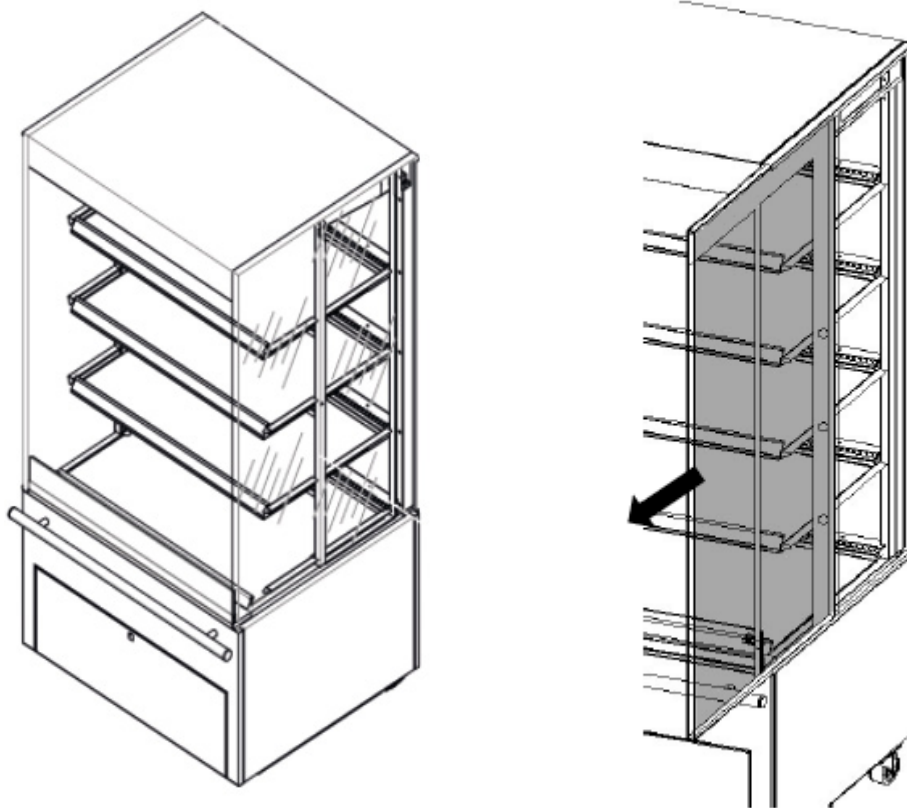

#### CAUTION:

Once past the middle, the glass pane might tilt forward when not properly held.



Be aware of the weight of the glass pane !

Hence do not leave it standing upright without being supported by both guide rails or holding it.



Be careful not to chip the edges of the glass. If chipped, the glass will break later on.

For safe keeping, please put cloth or cardboard between ground/wall and glass.

2. Before placing a new side pane, clean the guiding rails. (Top, bottom and back).
3. Before sliding the new pane into the rails, ensure the black screening side of the pane is facing backwards.
4. Slide it all the way back till the front of the pane is in line with the front plating.

## 8.0 Replacement and adjustment

### 8.1

#### Child glass replacement:



1. Remove front panel (see 8.2).
2. Loosen mounting screws (3x depending on unit length) of child guard glass.  
Screwed from underneath.
3. Place new child glass.
4. Mount in reverse order.

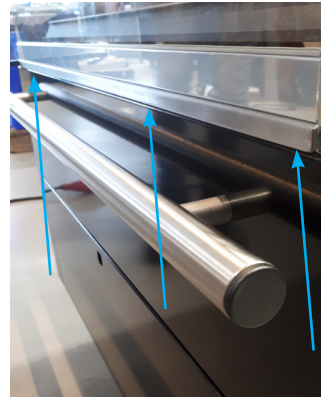

### 8.2

#### Panel Opening or Replacement:



1. Remove Plinths when mounted.

#### Front panel:



2. Remove front panel, by removing the holding Bolts (left and right bottom corner) Screwed from underneath.
3. Pull panel slightly towards you and down, to remove.
4. Replace in reverse order.



#### Back panel:



2. Remove back panel, by removing the holding screws (left and right bottom corner) Screwed from underneath.
3. Pull panel slightly towards you and down, to remove.
4. Replace in reverse order.



## 8.0 Replacement and adjustment

### 8.3.1 LED replacement Shelf:



1. Remove side glass panes. (Refer 8.0).
2. Remove column cover (middle right column cover, seen from customer side). (two screws, one on top backside and one at the bottom back side).
3. Take off column cover.
4. Remove screw holding the LED housing.
5. Disconnect connector in Column.



Before you do so, make a note of the placing of the red and black cable in the connector.

6. Take LED light out of LED light holder, and place new LED.
7. Connect the wires from the new LED in the column, taking care of the notes you made regarding the red and black cable.
8. Replace in reverse order.

### 8.3.2 LED replacement Top:



1. Top LED can be reached from the front side (customer side) of the MDD.
2. Remove screw holding the top LED (2 x one left, one right).
3. Disconnect connector (Left side).



Before you do so, make a note of the placing of the red and black cable in the connector.

4. Take LED light out and place new LED.
5. Connect the wires from the new LED in the column, taking care of the notes you made regarding the red and black cable.
6. Replace in reverse order.

## 8.0 Replacement and adjustment

### 8.4 Replacement shelf glass. :

1. Remove side glass panes, both sides. (Refer 8.0). 
2. Remove fan box top cover.(3 screws depending on unit length).
3. Remove Complete Solid back (6 screws depending on version).
4. Remove glass pane clamp. (4 or more bolts depending on unit length).
5. Remove Shelf Glass pane, by lifting it upwards.



### 8.5 Heating element replacement:



1. Remove side glass panes. (Refer 8.0).
2. Remove Shelf Glass pane. (Refer 8.4).
3. Remove fan box.(Refer 8.6).
3. Remove column cover (back right column cover, seen from customer side).
4. Loosen Element holders, fastened with screws. (1 screw each). 
5. Take off the top element holders.  
Heating Element is now free to take out.



Make a note of the placement of the wiring.

6. Take out element.

If possible, follow the wires going down in the column.

If not, cut the wire in the column, leaving enough length to make a connection to the wires from the new element, **inside the column.**



**NEVER make a connection underneath the heating element**



Connect the wires in the column using a wago connector like the one on this picture:



Take care of connecting:

Red to Red,

Blue to Blue, and

Yellow/green to Yellow/green. Most of the times, this wire can stay as is.

7. Replace in reverse order.

## 8.0 Replacement and adjustment

### 8.6 Fan box replacement:



1. Remove side glass panes, both sides. (Refer 8.0).
2. Remove fan box top cover (3 screws depending on unit length).

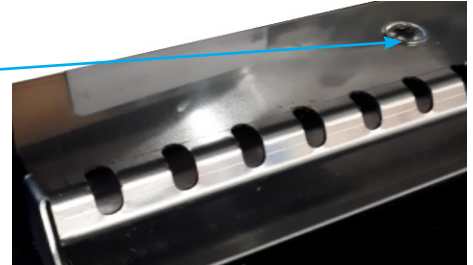

3. Remove Complete Solid back (6 screws depending on version).
4. Remove glass pane clamp. (4 or more bolts depending on unit length).



5. Remove Shelf Glass pane (refer 8.4).
6. Remove fan box (1 connector, two screws).

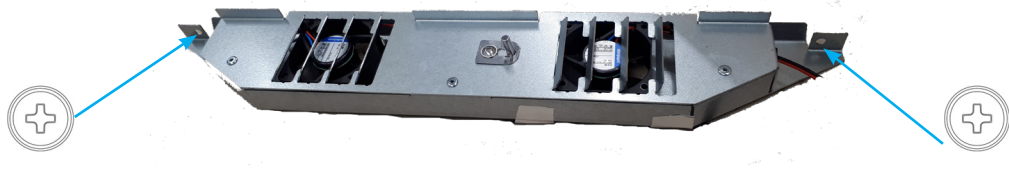

7. Replace in reverse order.

## 8.0 Replacement and adjustment

8.7

### PTC sensor replacement:



1. Remove fan box (Refer 8.5).
2. Remove Sensor bracket (one screw). 
3. Remove sensor from bracket.
4. Remove sensor from fan box via back side.
5. Open electrical box (Refer 8.8).
6. Follow sensor cable trough back side column into electrical box.
7. Disconnect cable from contact points in electrical box.
8. Insert new sensor, feeding cable in the same way as previous one.
9. Connect sensor cable on contact points in electrical box from which the old cable was disconnected.
10. Replace in reverse order.



## 8.0 Replacement and adjustment

8.8



### Replacement parts electrical box:

1. Open controller cover
2. Open controller cover by removing holding screws (2)
3. Remove 2 screws holding electrical box
4. Open electrical box.
5. Find item to be replaced.

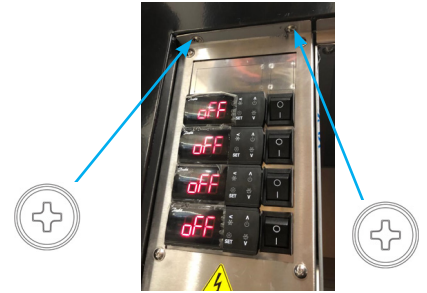

### Controller replacement:

1. Locate controller which is the problem (Multi temp can have up to 5 controllers).
2. Check wiring of controller, make a note of the wires (numbers) and their placing (numbers on controller).

3. Disconnect controller and take out. Note connection points



4. Mount new controller (as seen on drawing) and re-connect wiring.

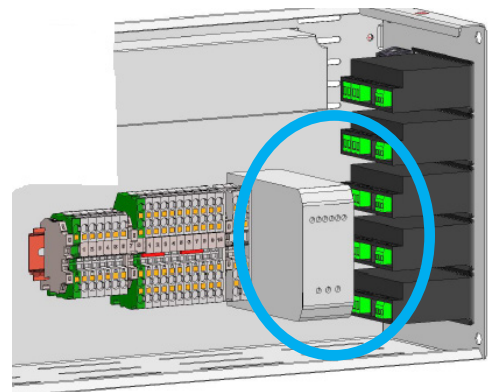

### PSU 24 volt replacement:

1. Locate 24V power supply (PSU for fans).
2. Check wiring of psu, make a note of the wires (numbers) and their placing (numbers on psu).
3. Disconnect psu and take out.
4. Mount new power supply and re-connect wiring.

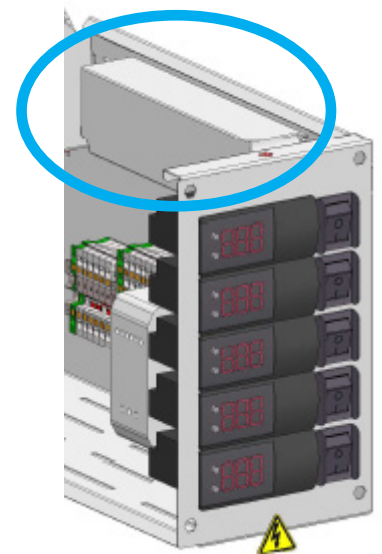

### Led driver replacement:

1. Locate LED driver.
2. Check wiring of LED driver, make a note of the wires (numbers) and their placing (numbers on LED driver).
3. Disconnect LED driver and take out.
4. Mount new LED driver and re-connect wiring according notes from point 2

## 8.0 Replacement and adjustment

### 8.9 Replacement back main switch:



1. Remove top back panel.  
3 screws, depending on unit length
2. Remove top back panel
3. Remove old switch
4. Connect new switch according left wiring.

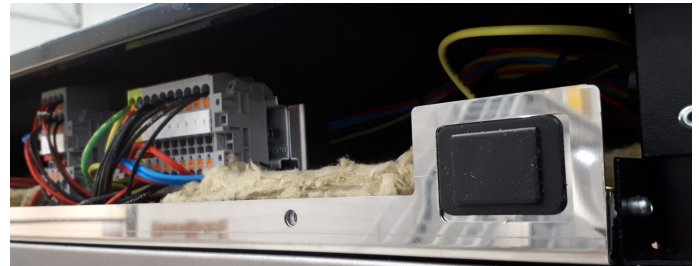
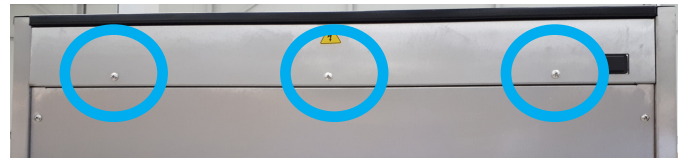

main switches

	S1			S2	
3	3A	6B	3	3A	6B
76	2A	5B	77	2A	5B
2	1A	4B	2	1A	4B









### 8.10 Replacement front main switch:



1. Remove top back panel.  
3 screws, refer 8.9.
2. Remove panel, refer 8.9.
3. Remove top panel 3 screws
4. Remove two bolts at back side,  
holding down the top panel.
5. Slightly lift top panel at back side,  
and push slightly forward.
6. When top panel is taken off, you can  
reach the front main switch.
7. Replace in reverse order.



## 8.0 Replacement and adjustment

	Wiring Supply Voltage
	Wiring LED, each LED has separate wiring
	Wiring ON/Off switch + PE bottom side
	Wiring top connection block, LED top + PE top
	Wiring fans
	Wiring heating elements

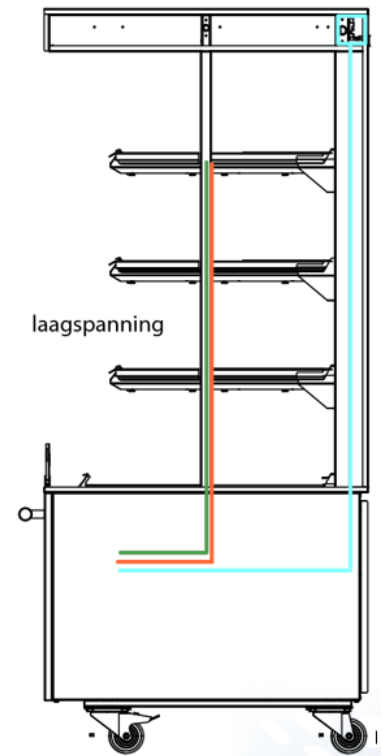
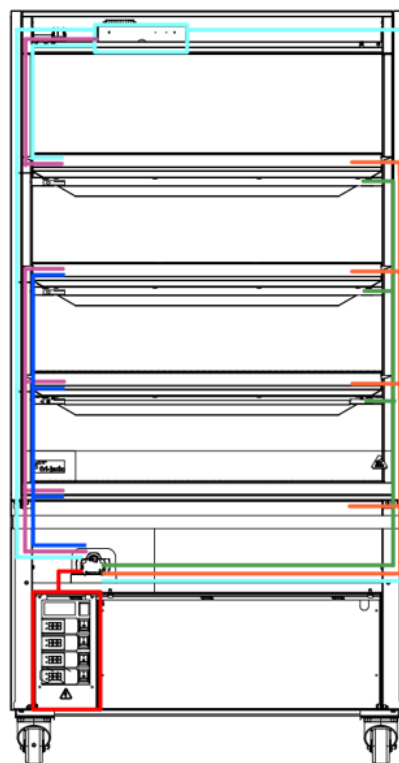
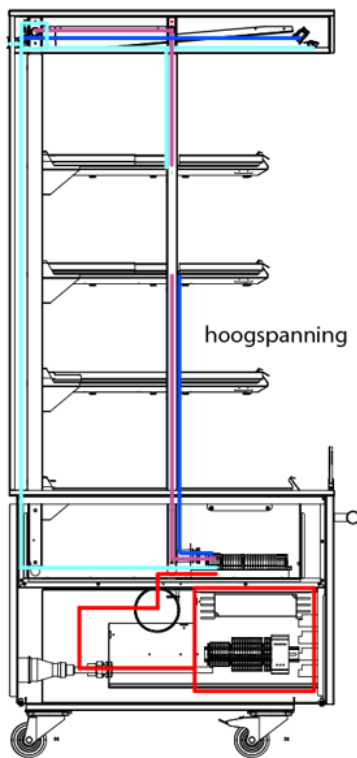

## 9.0.0 Specifications MDD - 3 Imperial



Specification		24-3	363	48-3
Length incl. end walls	Inch	23 5/8	35 7/16	47 1/4
Length excl. end walls	Inch	21 5/8	33 7/16	45 1/4
Depth excl. bump rail	Inch	29 1/2		
Depth incl. bump rail	Inch	31 7/8		
Height on wheels	Inch	56 13/16		
Height on leveling legs	Inch	55 15/16 (-0/+9/16)		
Under frame height	Inch	22 13/16		
Plinth height	Inch	3 15/16		
Weight (net)	lbs	335	397	459
Weight (gross)	lbs	392	467	542
Packaging dimensions (W x D x H)	inch	28 3/8 x 36 3/4 x 58 3/16	40 3/16 x 36 3/4 x 58 3/16	52 x 36 3/4 x 58 3/16
No. of presentation levels		3		
Dimensions bottom shelf	Inch	21 5/8 x 19 11/16	21 5/8 x 31 1/2	21 5/8 x 43 5/16
Dimensions upper shelves	Inch	18 11/16 x 19 11/16	18 11/16 x 31 1/2	18 11/16 x 43 5/16
Shelf display area	ft <sup>2</sup>	8,07	12,92	17,76
Usable display volume	ft <sup>3</sup>	4,66	7,45	10,24

Performance		24-3	36-3	48-3
Shelf display area	ft <sup>2</sup>	8,07	12,92	17,76
TEC at climate class 0*	BTU/h	3242	5152	7097
TEC at climate class 0*	BTU/day	77387	123827	170266
TEC/TDA at climate class 0*	BTU/day/ft <sup>2</sup>	9586		
Sound pressure	dB(A)	<70		
Minimum ambient temperature	°F	68		
Maximum ambient temperature	°F	86		
Maximum relative air humidity	%	60		

\* According to ISO 23953

Electrical		24-3	36-3	48-3
Electrical connection		NEMA 6-20P*		NEMA 15-30P*
Nominal voltage	V	1~ 208		3~ 208
Nominal Frequency	Hz	50/60		
Maximum power	W	2287	3161	4211
Required fuses		1 x 20A		3 x 20A
Heating fan power	W	11	16	22
Nr. of heating fans (total)	#	6	9	12
Heating element bottom shelf power	W	750 (-0/+10%)	1125 (-0/+10%)	1500 (-0/+10%)
Heating element upper shelves power	W	650 (-0/+10%)	850 (-0/+10%)	1130 (-0/+10%)
LED lighting power	W	21	37	53

\*\* Standard Plug

## 9.0.1 Specifications MDD - 4 Imperial



Specification		24-4	36-4	48-4
Length incl. end walls	Inch	23 5/8	35 7/16	47 1/4
Length excl. end walls	Inch	21 5/8	33 7/16	45 1/4
Depth excl. bump rail	Inch	29 1/2		
Depth incl. bump rail	Inch	31 7/8		
Height on wheels	Inch	67 13/16		
Height on leveling legs	Inch	66 15/16 (-0/+9/16)		
Under frame height	Inch	22 13/16		
Plinth height	Inch	3 15/16		
Weight (net)	lbs	419	485	551
Weight (gross)	lbs	500	584	668
Packaging dimensions (W x D x H)	inch	28 3/8 x 36 3/4 x 69 3/16	40 3/16 x 36 3/4 x 69 3/16	52 x 36 3/4 x 69 3/16
No. of presentation levels		4		
Dimensions bottom shelf	Inch	21 5/8 x 19 11/16	21 5/8 x 31 1/2	21 5/8 x 43 5/16
Dimensions upper shelves	Inch	18 11/16 x 19 11/16	18 11/16 x 31 1/2	18 11/16 x 43 5/16
Shelf display area	ft <sup>2</sup>	10,66	17,01	23.36
Usable display volume	ft <sup>3</sup>	5,69	9,08	12.50

Performance		24-4	36-4	48-4
Shelf display area	ft <sup>2</sup>	10,66	17,01	23.36
TEC at climate class 0*	BTU/h	4265	6790	9315
TEC at climate class 0*	BTU/day	102160	162008	223905
TEC/TDA at climate class 0*	BTU/day/ft <sup>2</sup>	9586		
Sound pressure	dB(A)	<70		
Minimum ambient temperature	°F	68		
Maximum ambient temperature	°F	86		
Maximum relative air humidity	%	60		

\* According to ISO 23953

Electrical		24-4	36-4	48-4
Electrical connection		NEMA 6-20P**	NEMA 15-30P**	
Nominal voltage	V	1~ 208	3~ 208	
Nominal Frequency	Hz	50/60		
Maximum power	W	3006	4104	5463
Required fuses		1 x 20A	3 x 20A	
Heating fan power	W	14	22	30
Nr. of heating fans (total)	#	8	12	16
Heating element bottom shelf power	W	750 (-0/+10%)	1125 (-0/+10%)	1500 (-0/+10%)
Heating element upper shelves power	W	650 (-0/+10%)	850 (-0/+10%)	1130 (-0/+10%)
LED lighting power	W	22	39	54

\*\* Standard Plug

## 9.0.2 Specifications MDD - 5 Imperial



Specification		24-5	36-5	48-5
Length incl. end walls	Inch	23 5/8	35 7/16	47 1/4
Length excl. end walls	Inch	21 5/8	33 7/16	45 1/4
Depth excl. bump rail	Inch	29 1/2		
Depth incl. bump rail	Inch	31 7/8		
Height on wheels	Inch	77 11/16		
Height on leveling legs	Inch	76 3/4 (-0/+9/16)		
Under frame height	Inch	22 13/16		
Plinth height	Inch	3 15/16		
Weight (net)	lbs	461	560	661
Weight (gross)	lbs	542	659	778
Packaging dimensions (W x D x H)	inch	28 3/8 x 36 3/4 x 69 3/16	40 3/16 x 36 3/4 x 69 3/16	52 x 36 3/4 x 69 3/16
No. of presentation levels		5		
Dimensions bottom shelf	Inch	21 5/8 x 19 11/16	21 5/8 x 31 1/2	21 5/8 x 43 5/16
Dimensions upper shelves	Inch	18 11/16 x 19 11/16	18 11/16 x 31 1/2	18 11/16 x 43 5/16
Shelf display area	ft <sup>2</sup>	13,24	21,10	29,06
Usable display volume	ft <sup>3</sup>	5,69	11,27	15,50

Performance		24-5	36-5	48-5
Shelf display area	ft <sup>2</sup>	13,24	21,10	29,06
TEC at climate class 0*	BTU/h	5630	8428	11226
TEC at climate class 0*	BTU/day	126932	202272	278601
TEC/TDA at climate class 0*	BTU/day/ft <sup>2</sup>	9586		
Sound pressure	dB(A)	<70		
Minimum ambient temperature	°F	68		
Maximum ambient temperature	°F	86		
Maximum relative air humidity	%	60		

\* According to ISO 23953

Electrical		24-5	36-5	48-5
Electrical connection		NEMA 6-20P**	NEMA 15-30P**	
Nominal voltage	V	1~ 208	3~ 208	
Nominal Frequency	Hz	50/60		
Maximum power	W	3730	5054	6726
Required fuses		1 x 20A	3 x 30A	
Heating fan power	W	18	27	36
Nr. of heating fans (total)	#	10	15	20
Heating element bottom shelf power	W	750 (-0/+10%)	1125 (-0/+10%)	1500 (-0/+10%)
Heating element upper shelves power	W	650 (-0/+10%)	850 (-0/+10%)	1130 (-0/+10%)
LED lighting power	W	27	49	68

\*\* Standard Plug

## 9.1.1 Specifications MDD 24'' - 3 Imperial PT - SB

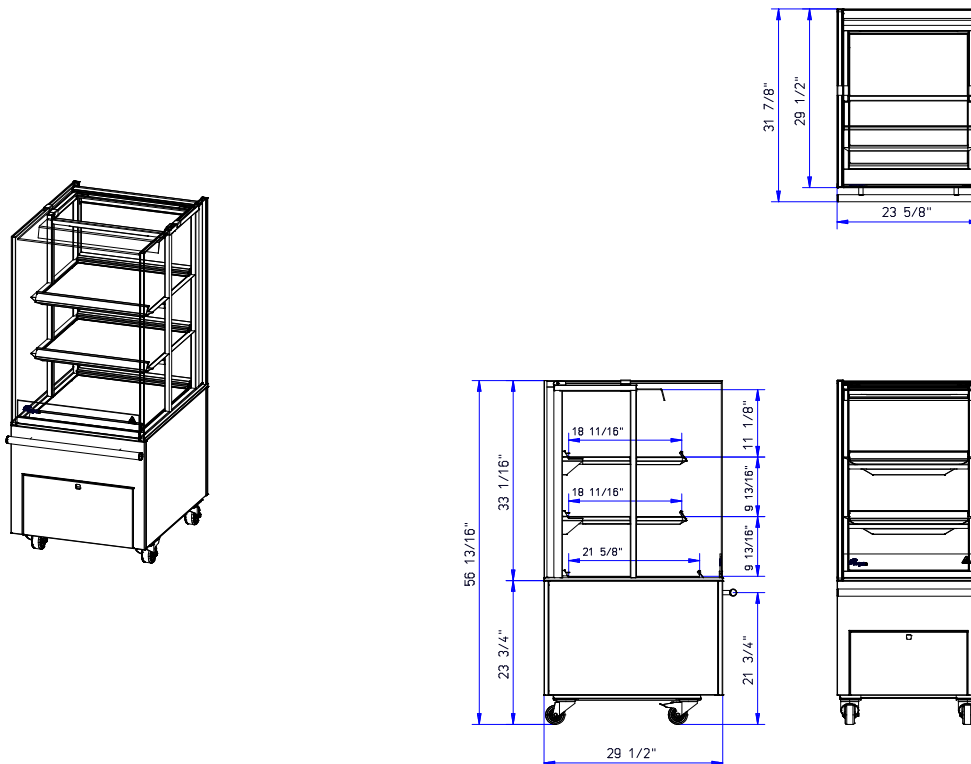
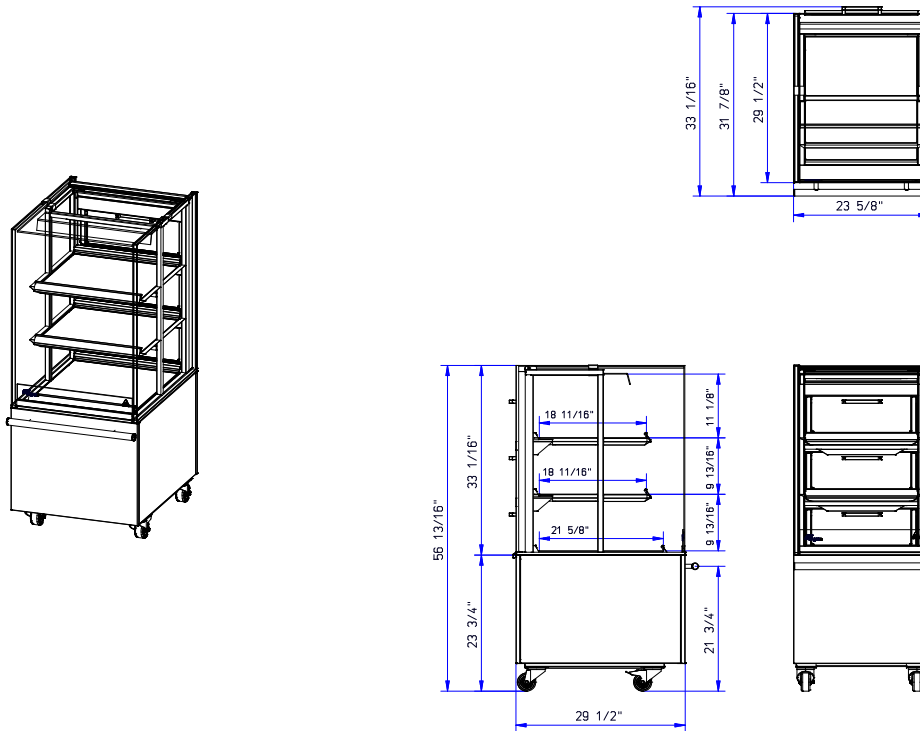

## 9.2.1 Specifications MDD 24"- 4 Imperial PT - SB

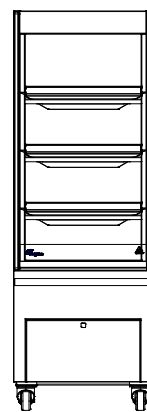
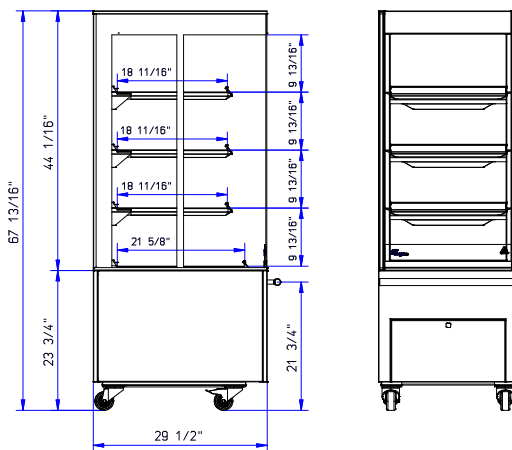
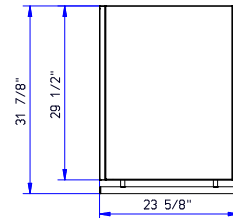
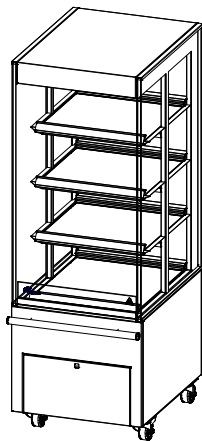
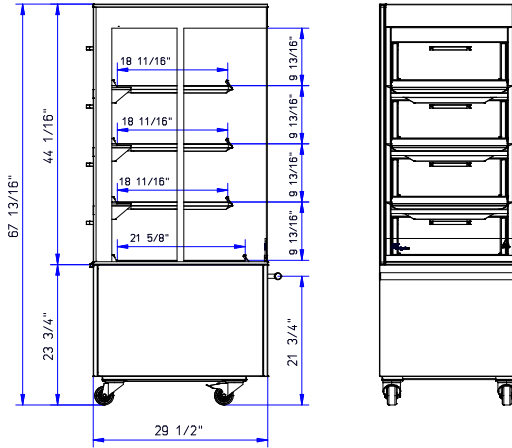
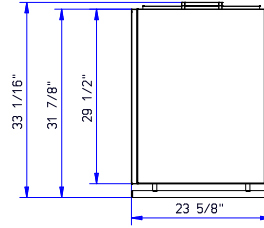
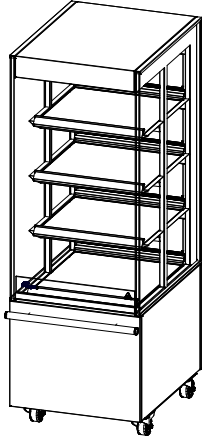

## 9.3.1 Specifications MDD 24'' - 5 Imperial PT - SB

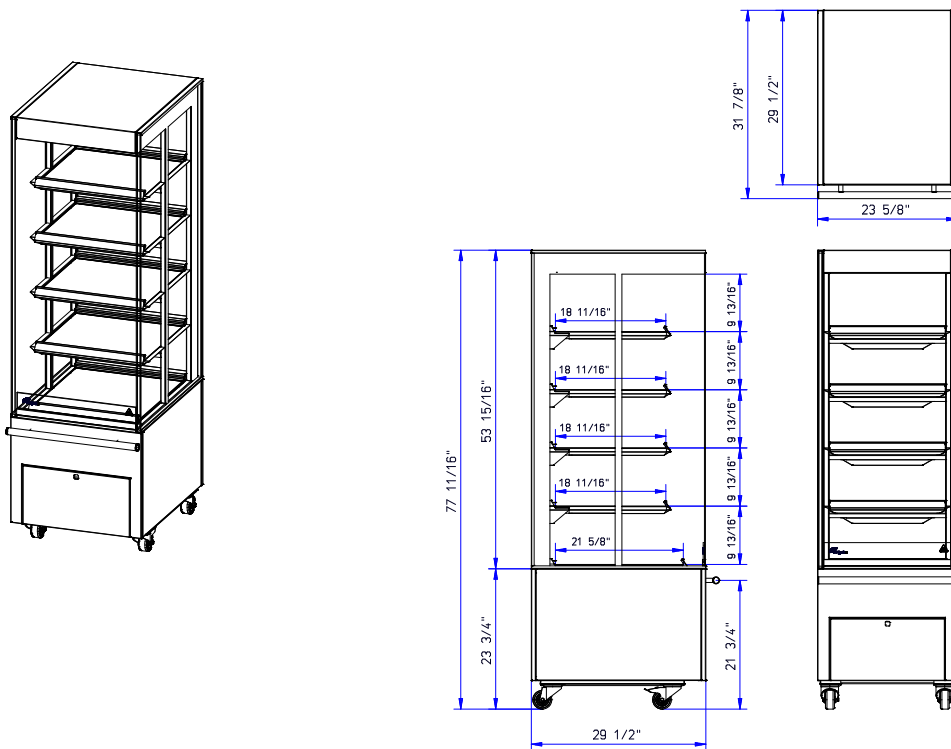
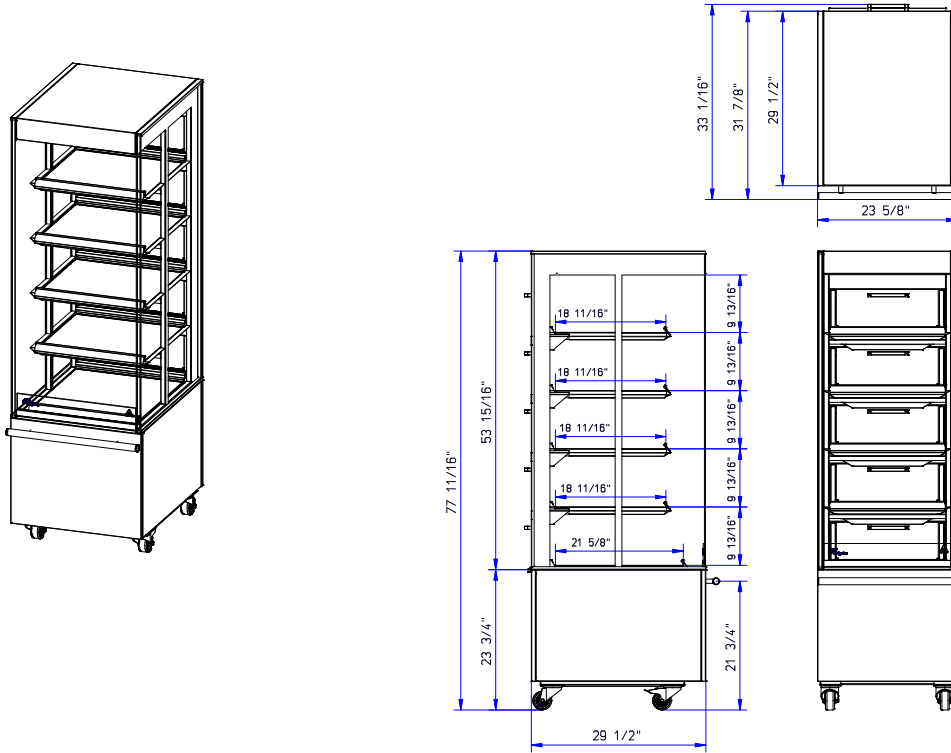

## 9.4.1 Specifications MDD 36'' - 3 Imperial PT - SB

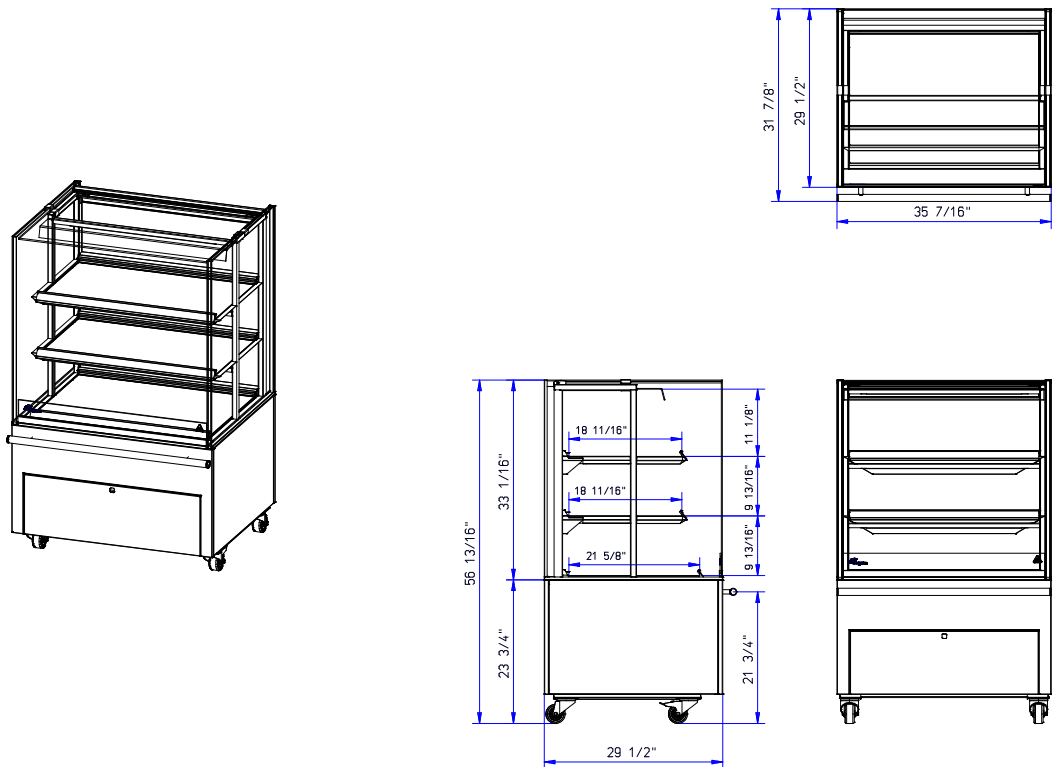
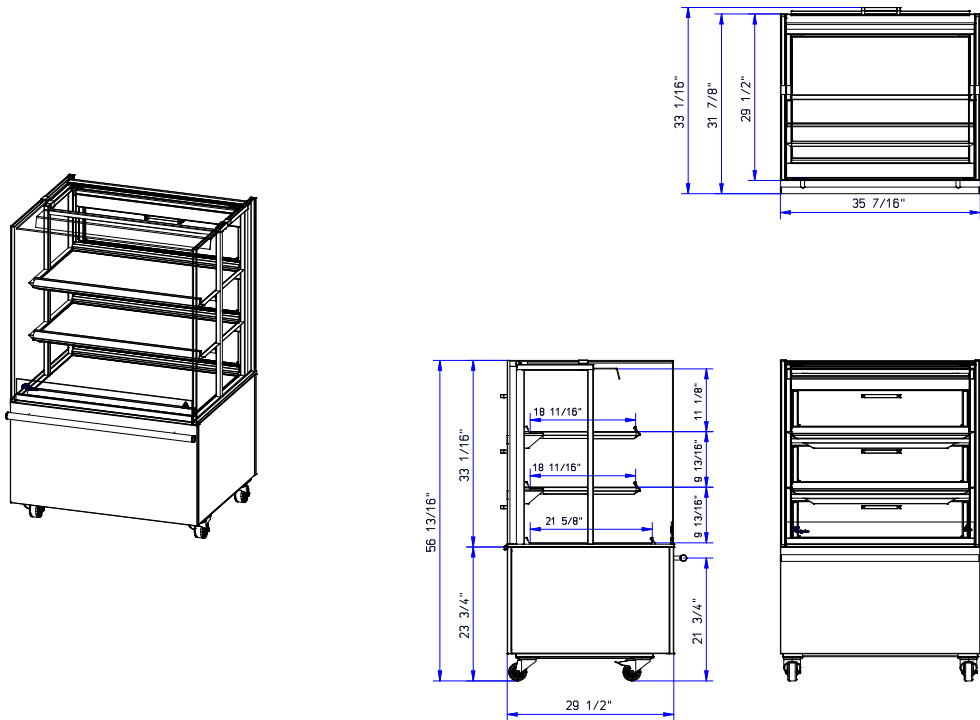

## 9.5.1 Specifications MDD 36'' - 4 Imperial PT - SB

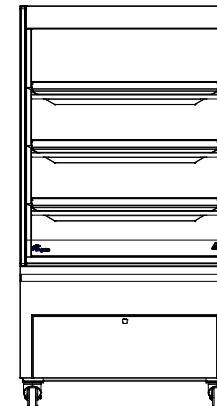
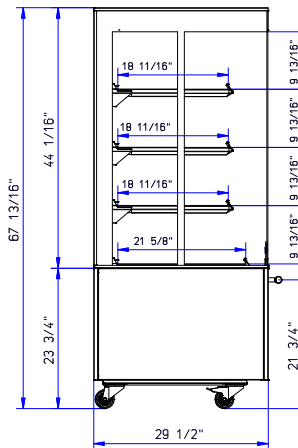
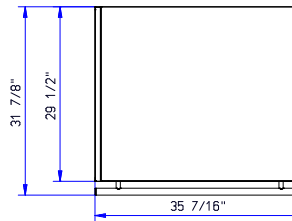
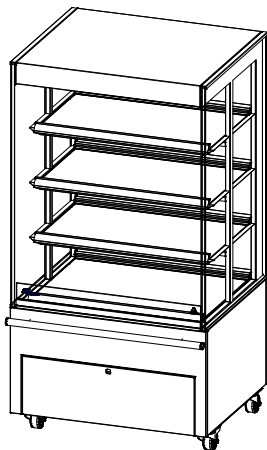
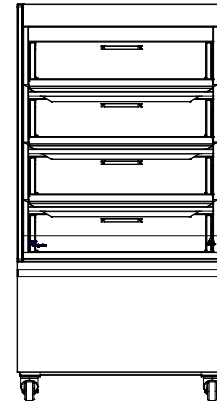
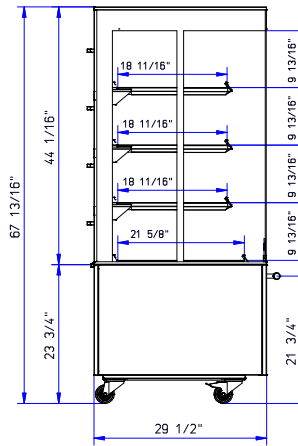
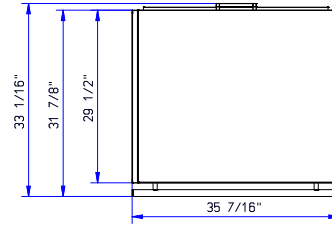
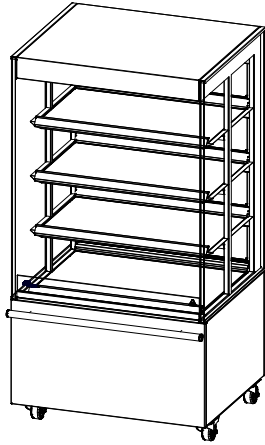

## 9.6.1 Specifications MDD 36'' - 5 Imperial PT - SB

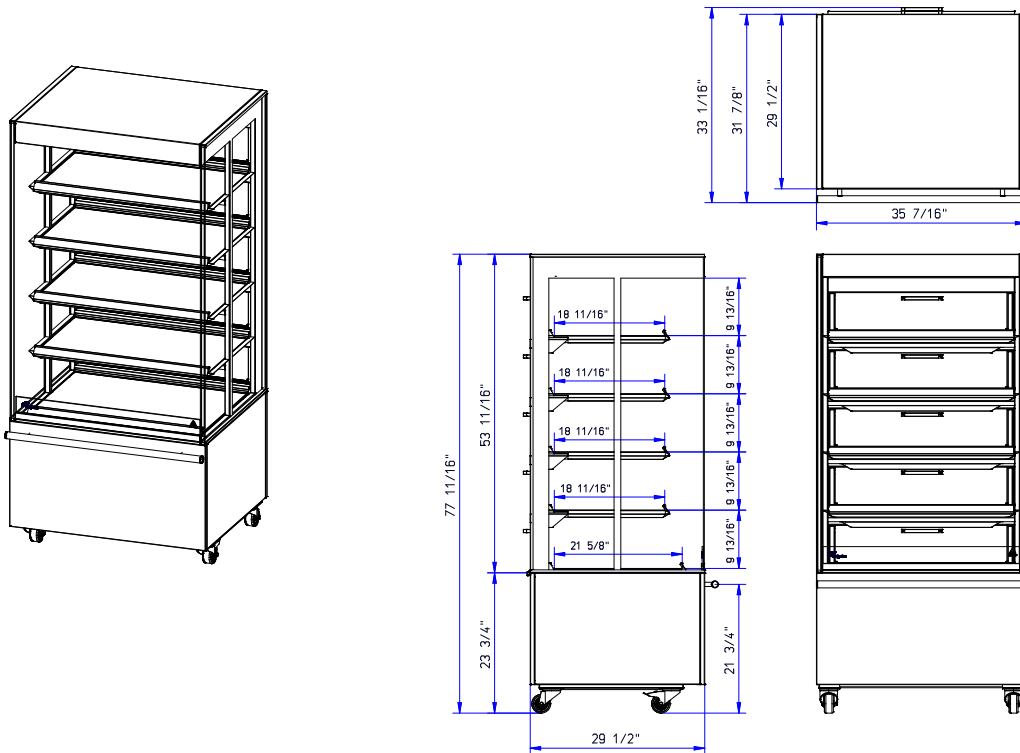
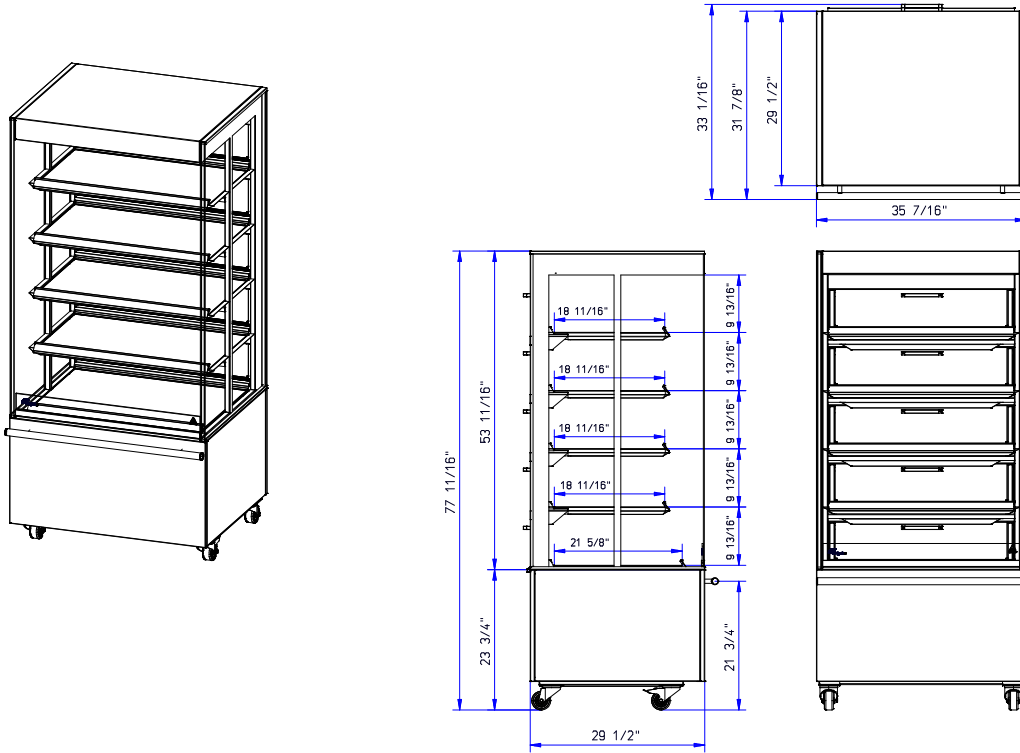

## 9.7.1 Specifications MDD 48'' - 3 Imperial PT - SB

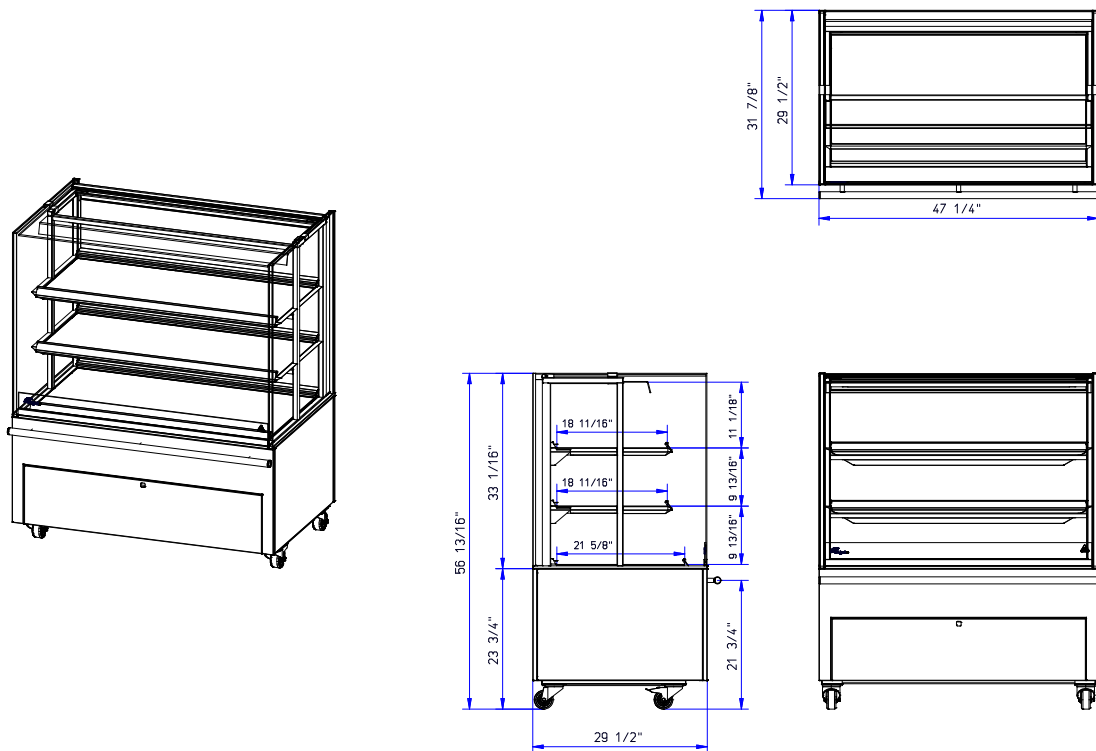
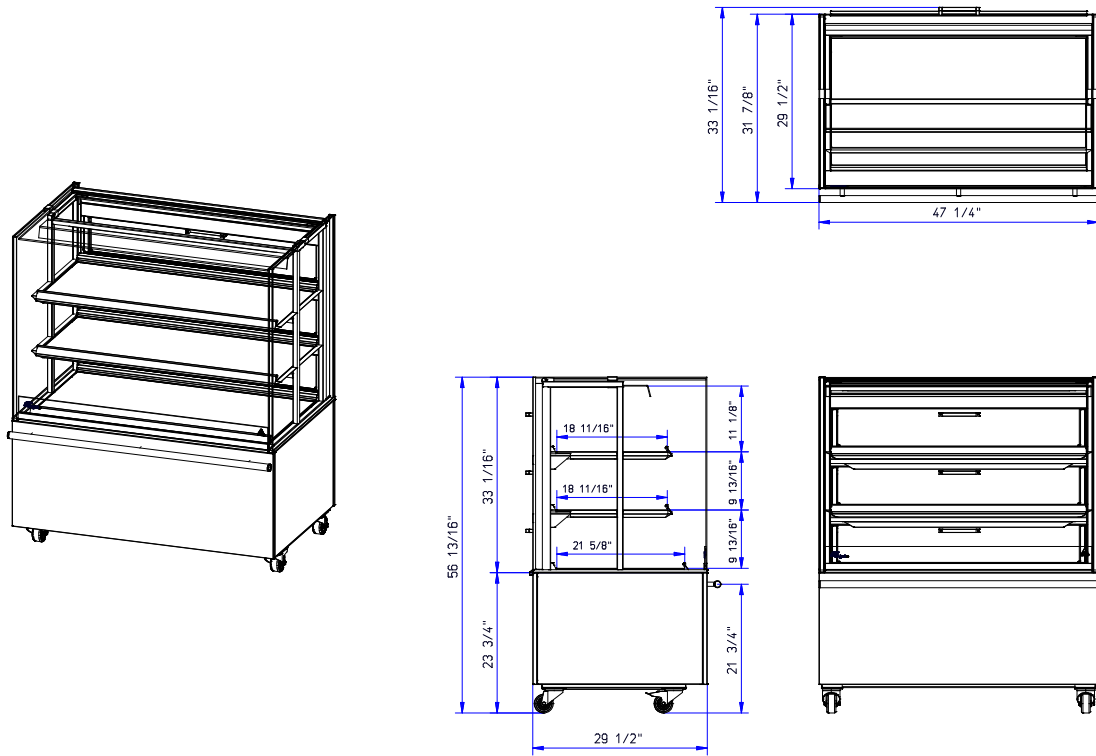



## 9.9.1 Specifications MDD 48'' - 5 Imperial PT - SB

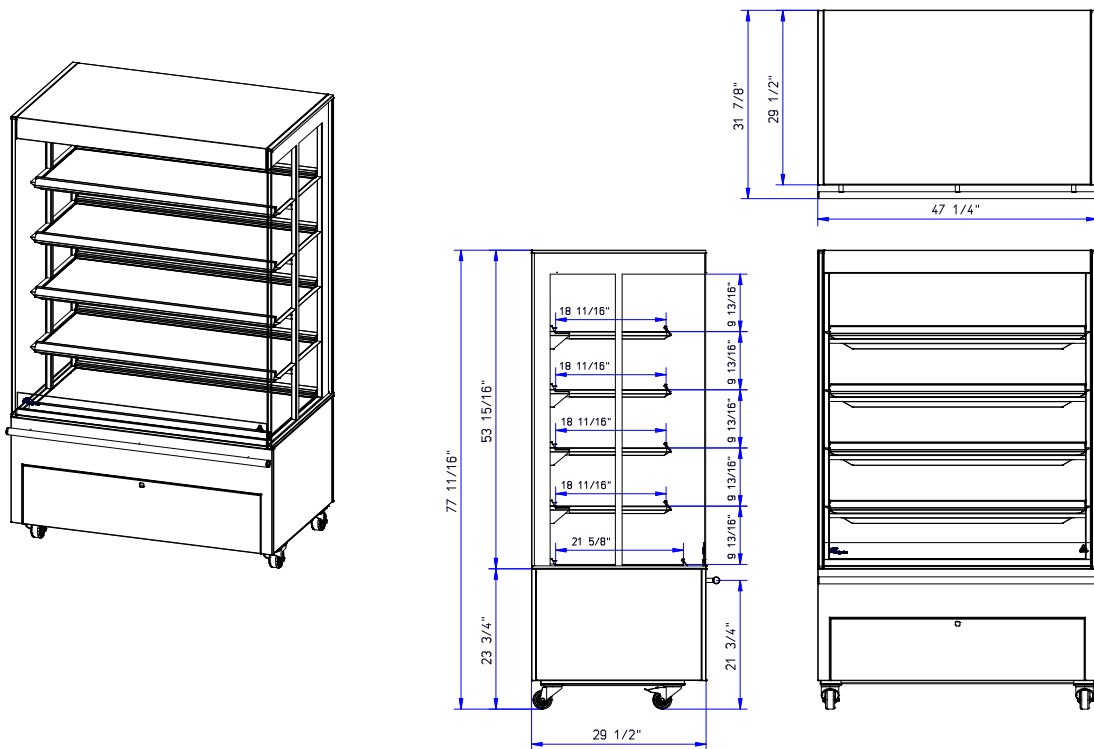
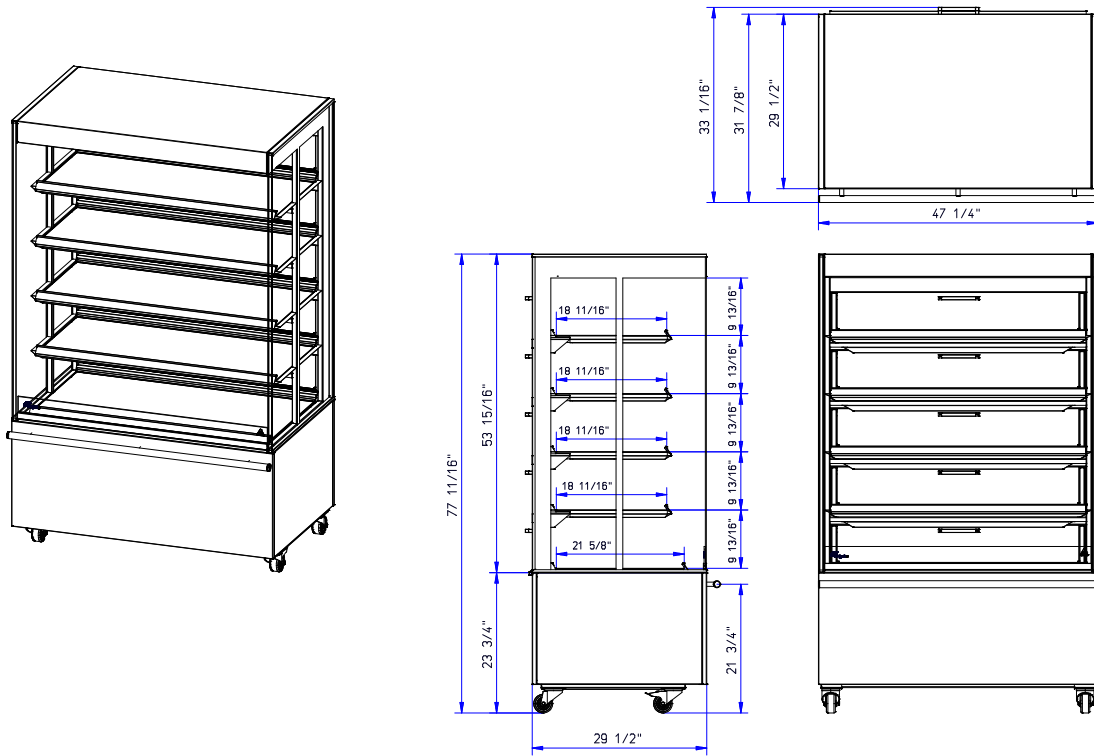

## 10.0 Exploded view 4 - 5 level

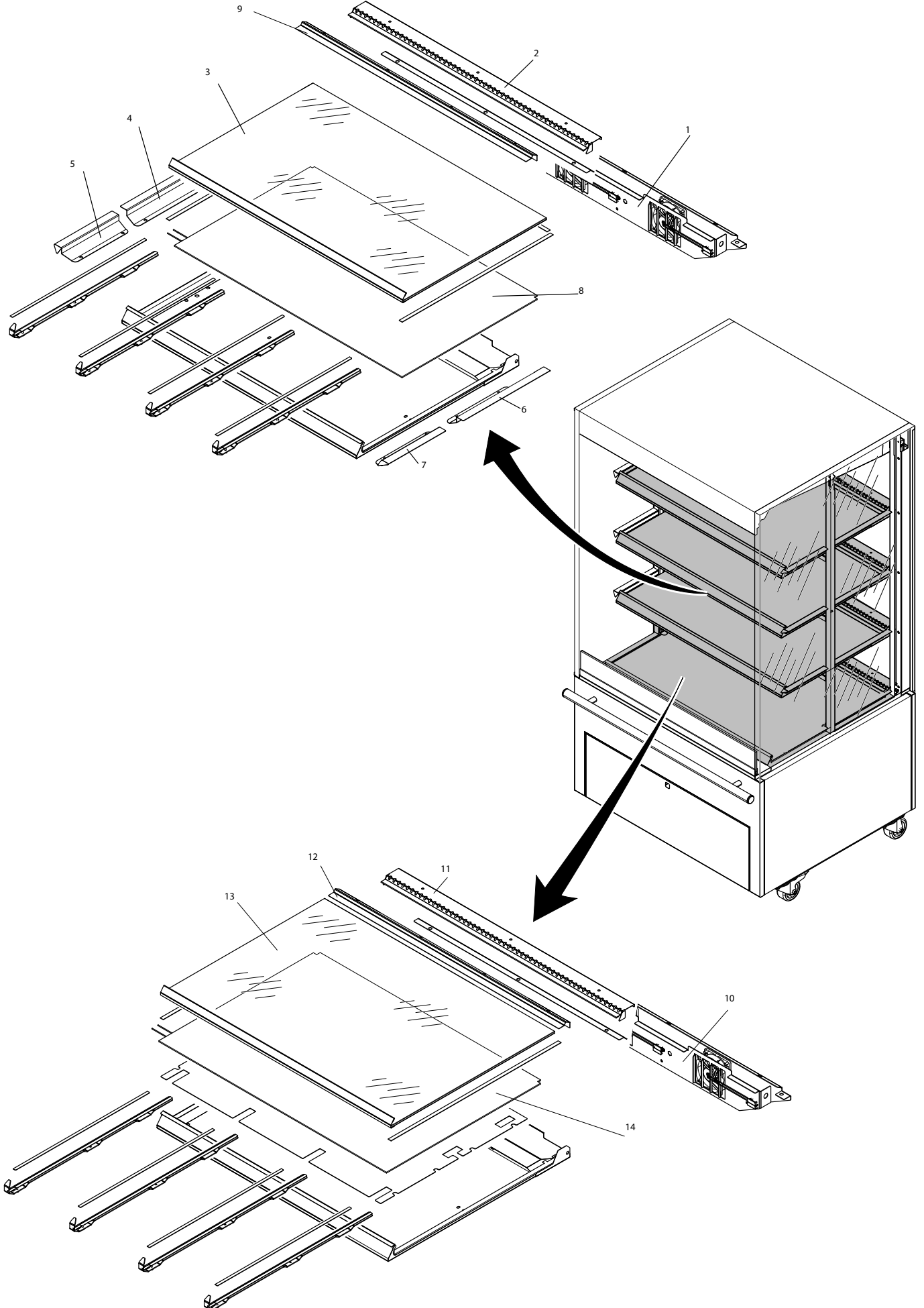

## 10.0 Exploded view 4 - 5 level

Number	Description	Article number	Quantity
1	Fan box MDD 24 Fan box MDD 36 Fan box MDD 48	9380310 9380308 9380306	4 - 5
2	Rear cover Shelf MDD 24 Rear cover Shelf MDD 36 Rear cover Shelf MDD 48	9384393 9384394 9384395	4 - 5
3	Shelf Glass pane MDD 24 Shelf Glass pane MDD 36 Shelf Glass pane MDD 48	9382036 9382039 9382080	3 - 4
4	Air blocker Left rear	9394045	3 - 4
5	Air blocker Left Front	9384068	3 - 4
6	Air blocker Right rear	9394044	3 - 4
7	Air blocker Right Front	9384069	3 - 4
8	Shelf Heating Element MDD 24: 475x470 570W Shelf Heating Element MDD 36: 775x400 850W Shelf Heating Element MDD 48: 1075x470 1130W	9382089 9382092 9382095	3 - 4
9	Glass clamp shelf MDD 24 Glass clamp shelf MDD 36 Glass clamp shelf MDD 48	9384359 9384322 9384360	4 - 5
10	Bottom Fan box MDD 24 Bottom Fan box MDD 36 Bottom Fan box MDD 48	9380310 9380308 9380306	1
11	Rear cover Shelf MDD 24 Rear cover Shelf MDD 36 Rear cover Shelf MDD 48	9384393 9384394 9384395	4 - 5
12	Glass clamp shelf MDD 24 Glass clamp shelf MDD 36 Glass clamp shelf MDD 48	9384359 9384322 9384360	4 - 5
13	Bottom Shelf Glass pane MDD 24 Bottom Shelf Glass pane MDD 36 Bottom Shelf Glass pane MDD 48	9382037 9382040 9382081	3 - 4
14	Bottom Heating Element MDD 24: 475x540 750W Bottom Heating Element MDD 36: 775x540 1125W Bottom Heating Element MDD 48: 1075x540 1500W	9382090 9382093 9382096	1 1 1

# 10.0 Exploded view 4 - 5 level

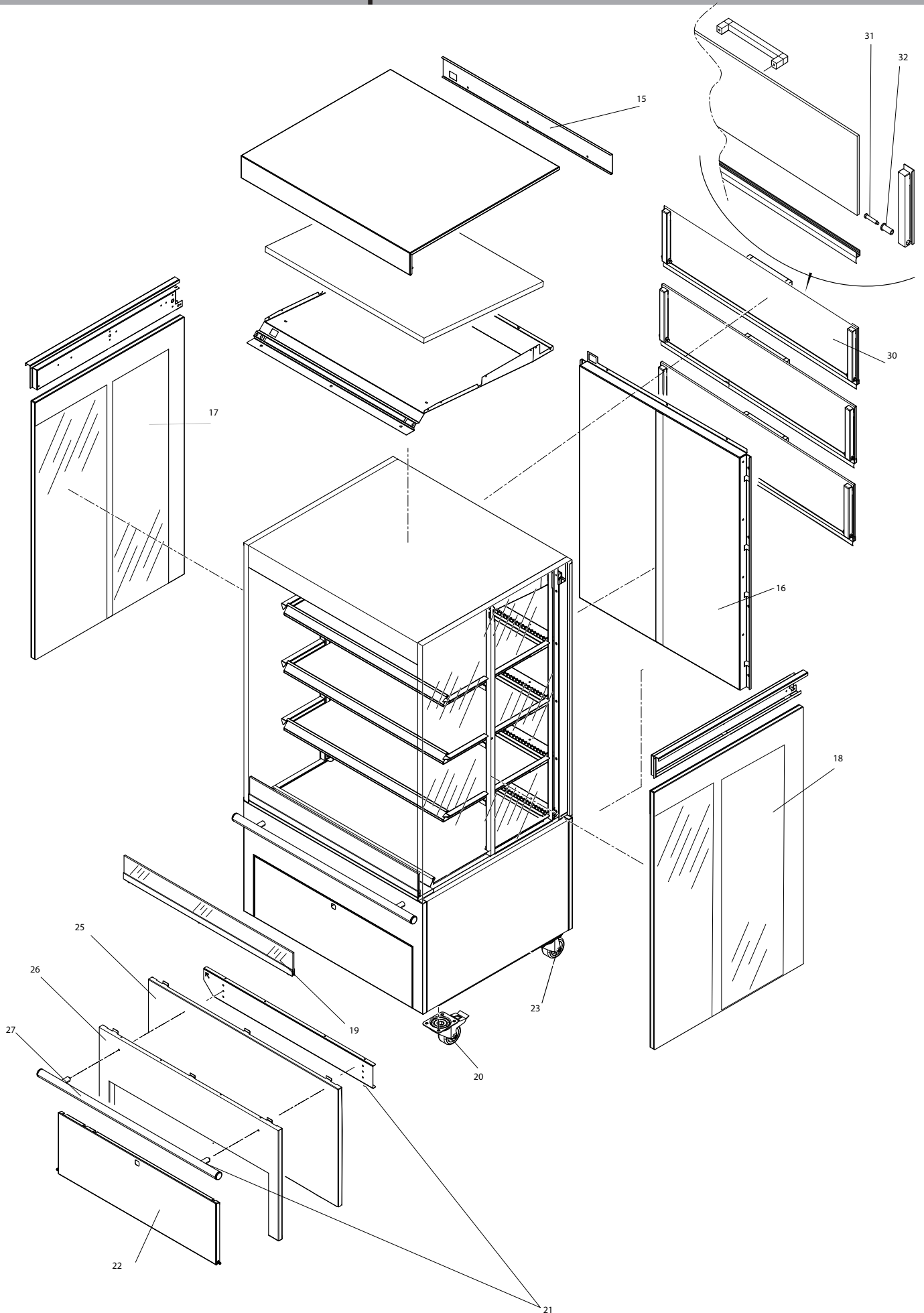

## 10.0 Exploded view 4 - 5 level

Number	Description	Article number	Quantity
15	Back panel top MDD 24 Back panel top MDD 36 Back panel top MDD 48	9394053 9394051 9394050	1
16 4 layer	Solid back panel MDD 24-4 Solid back panel MDD 36-4 Solid back panel MDD 48-4	9390031 9390029 9390053	1
16 5 layer	Solid back panel MDD 24-5 Solid back panel MDD 36-5 Solid back panel MDD 48-5	9390032 9390030 9390028	1
17	Glass pane Left MDD 4 layer Glass pane Left MDD 5 layer	9392001s 9392002s	1
18	Glass pane Right MDD 4 layer Glass pane Right MDD 5 layer	9392006s 9392007s	1
19	Child guard glass MDD 24 Child guard glass MDD 36 Child guard glass MDD 48	9380017 9380018 9380019	1
20	Swivel castor with brake	9172066	2
21	Bumper set MDD 24 Bumper set MDD 36 Bumper set MDD 48	9380206 9380207 9380205	1
22	Front panel MDD 24 Front panel MDD 36 Front panel MDD 48	*9390050xs *9390047xs *9390051xs	1
23	Swivel castor	9172065	2
26	Back panel UF MDD 24 Back panel UF MDD 36 Back panel UF MDD 48	9394077x	1 1 1
30	Assy flap door 24 Assy flap door 36 Assy flap door 48	9390092 9390091 9390075	4 - 5
31	Hinge pin (bolt)	9382261	2
32	Bearing	9382763	2
		* x stands for Ral color	

# 10.1 Exploded view 3 level

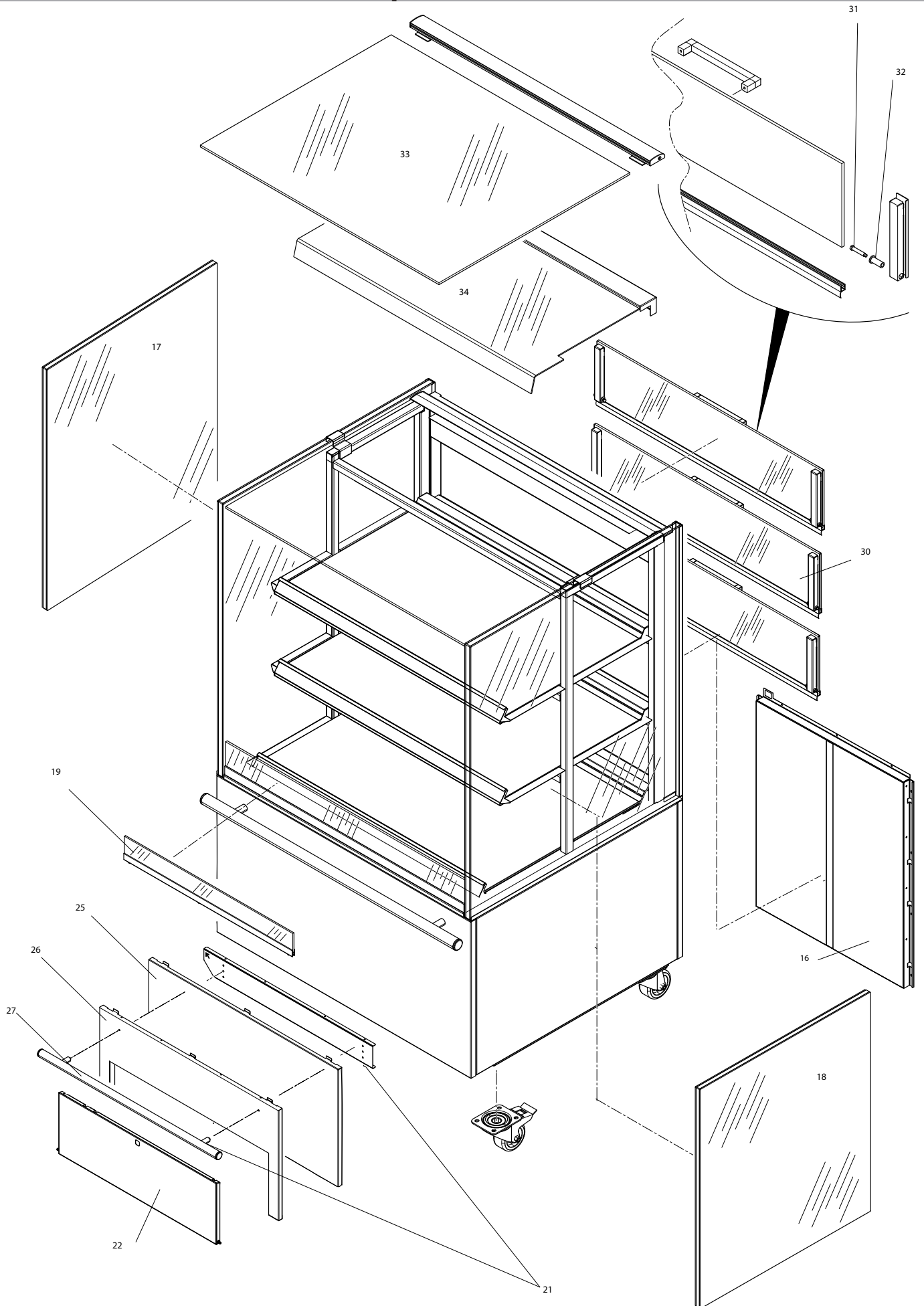

## 10.1 Exploded view 3 level

Number	Description	Article number	Quantity
15	Back panel top MDD 24	9394053	1
	Back panel top MDD 36	9394051	1
	Back panel top MDD 48	9394050	1
16	Solid back panel MDD 24-3	9390115	1
	Solid back panel MDD 36-3	9390112	1
	Solid back panel MDD 48-3	9390076	1
17	Glass pane Left MDD 3 layer	9382030	1
18	Glass pane Right MDD 3 layer	9382030	1
19	Child guard glass MDD 24	9380017	1
	Child guard glass MDD 36	9380018	1
	Child guard glass MDD 48	9380019	1
20	Swivel castor with brake	9172066	2
21	Bumper set MDD 24	9380206	1
	Bumper set MDD 36	9380207	1
	Bumper set MDD 48	9380205	1
22	Front panel MDD 24	*9390050xs	1
	Front panel MDD 36	*9390047xs	1
	Front panel MDD 48	*9390051xs	1
23	Swivel castor	9172065	2
30	Flap door 24	9390092	1
	Flap door 36	9390091	1
	Flap door 48	9390075	1
31	Hinge pin (bolt)	9382261	6
32	Bearing	9382763	6
33	Top glass 24	9382165	1
	Top glass 36	9382164	1
	Top glass 48	9382166	1
34	Air guide 24	9382062	1
	Air guide 36	9382061	1
	Air guide 48	9382063	1
		* x stands for Ral color	

## 10.1 Exploded view 3 level

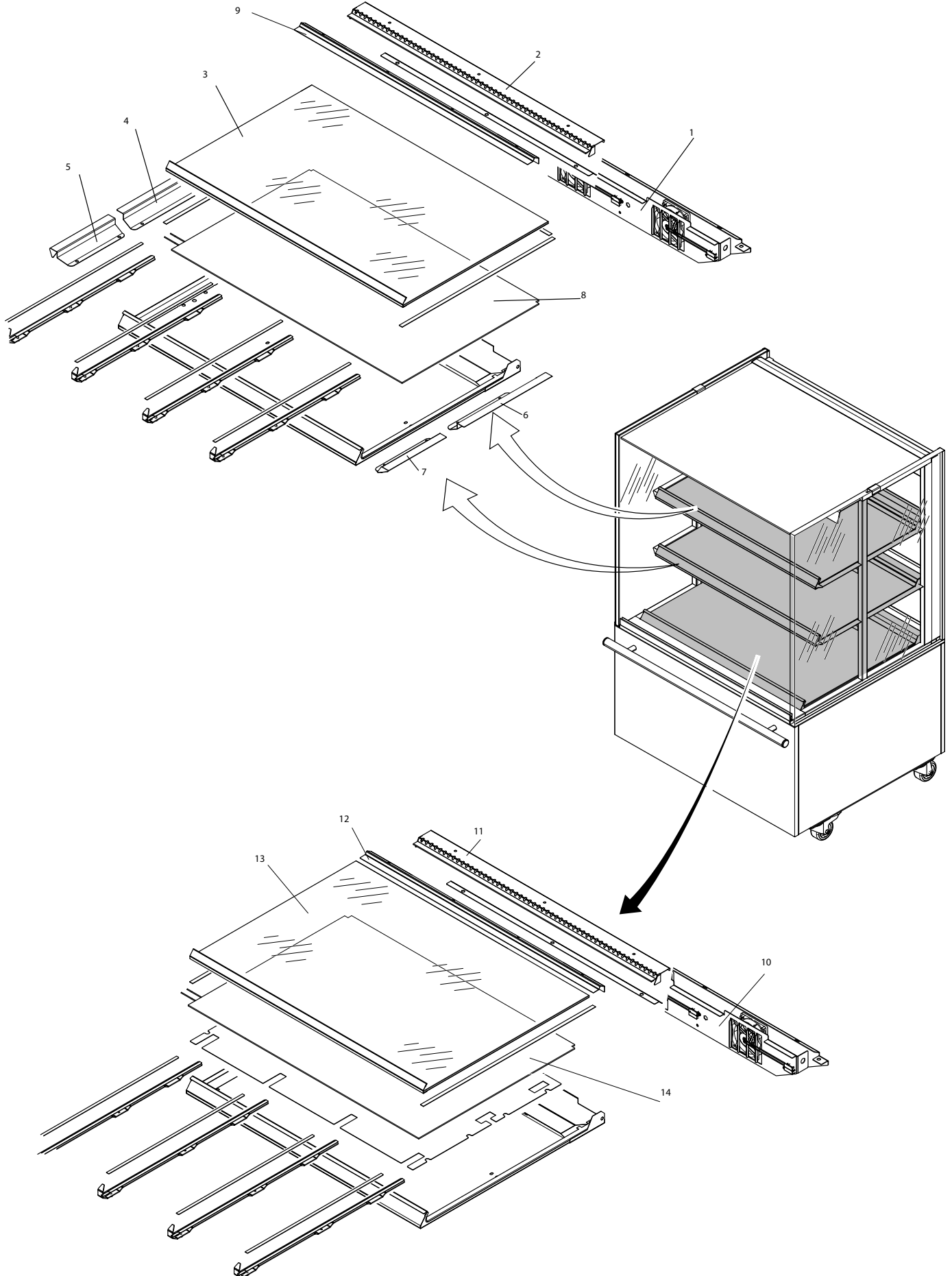

## 10.1 Exploded view 3 level

Number	Description	Article number	Quantity
1	Fan box MDD 24 Fan box MDD 36 Fan box MDD 48	9380310 9380308 9380306	4 - 5
2	Rear cover Shelf MDD 24 Rear cover Shelf MDD 36 Rear cover Shelf MDD 48	9384393 9384394 9384395	4 - 5
3	Shelf Glass pane MDD 24 Shelf Glass pane MDD 36 Shelf Glass pane MDD 48	9382036 9382039 9382080	3 - 4
4	Air blocker Left rear	9394045	3 - 4
5	Air blocker Left Front	9384068	3 - 4
6	Air blocker Right rear	9394044	3 - 4
7	Air blocker Right Front	9384069	3 - 4
8	Shelf Heating Element MDD 24: 475x470 570W Shelf Heating Element MDD 36: 775x400 850W Shelf Heating Element MDD48: 1075x470 1130W	9382089 9382092 9382095	3 - 4
9	Glass clamp shelf MDD 24 Glass clamp shelf MDD 36 Glass clamp shelf MDD 48	9384359 9384322 9384360	4 - 5
10	Bottom Fan box MDD 24 Bottom Fan box MDD 36 Bottom Fan box MDD48	9380310 9380308 9380306	1
11	Rear cover Shelf MDD 24 Rear cover Shelf MDD 36 Rear cover Shelf MDD 48	9384393 9384394 9384395	4 - 5
12	Glass clamp shelf MDD 24 Glass clamp shelf MDD 36 Glass clamp shelf MDD 48	9384359 9384322 9384360	4 - 5
13	Bottom Shelf Glass pane MDD 24 Bottom Shelf Glass pane MDD 36 Bottom Shelf Glass pane MDD 48	9382037 9382040 9382081	3 - 4
14	Bottom Heating Element MDD 24: 475x540 750W Bottom Heating Element MDD 36: 775x540 1125W Bottom Heating Element MDD 48:1075x540 1500W	9382090 9382093 9382096	1

## 10.2 Exploded view Electrical (first version)

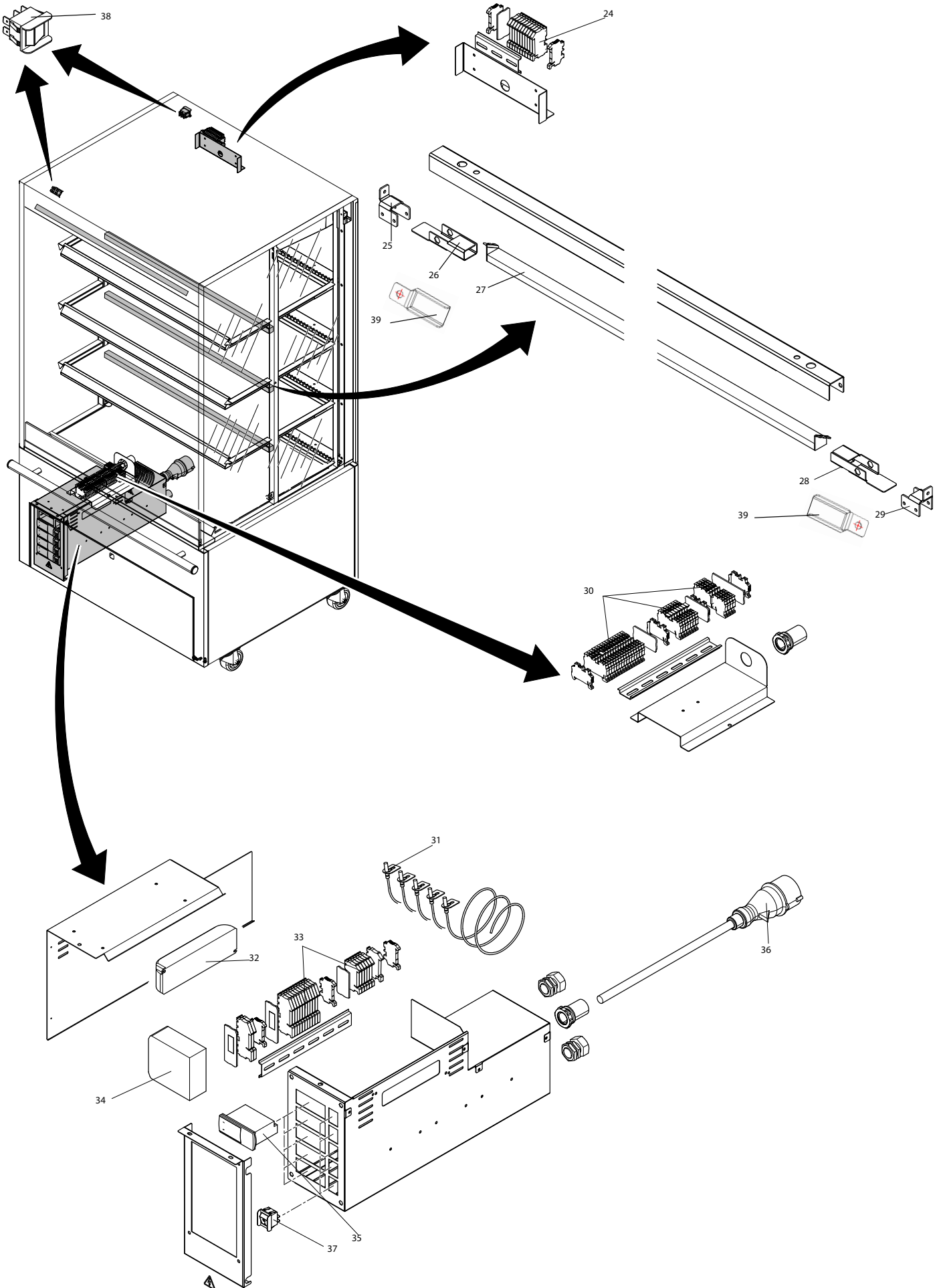

## 10.2 Exploded view Electrical

Number	Description	Article number	Quantity
24	Terminal PT 4 GY 4 way Terminal PT 4 GN/YE 4 way Terminal PT 4 BU	9191240 9191239 9191241	
25	LED Armature Support Bracket Shelf	9384091	6 - 8
26	LED mounting bracket Shelf	9384093	6 - 8
27	LED MDD 60 3000k 12V 400mm LED MDD 90 3000k 12V 700mm LED MDD 120 3000k 12V 1000mm	9382075 9382067 9382068	4 - 5
28	LED mounting bracket Shelf	9384093	6 - 8
29	LED Armature Support Bracket Shelf	9384091	6 - 8
30	Terminal PT 4 GY 2 way Terminal PT 4 GN/YE 2 way	9191232 9191233	
30	Terminal PT 4 GY 4 way Terminal PT 4 GN/YE 4 way Terminal PT 4 BU	9191240 9191239 9191241	
31	Sensor PTC1000	9221011	1 - 5
32	LED Driver	9381038	1
33	Terminal PT 4 GY 2 way Terminal PT 4 GN/YE 2 way	9191232 9191233	
33	Terminal PT 4 GY 4 way Terminal PT 4 GN/YE 4 way Terminal PT 4 BU	9191240 9191239 9191241	
34	Power supply 24V DC 40W	9381012	
35	Thermostat Eliwell ICPlus902	9281071	1 - 5
36	Power cord	9070028	1
37	Switch black 1-0 250V Guarded	9281036	1 - 5
38	Switch on-on 250V with guard	9391001	2
39	LED Holder Top LED	9394070	2

## 10.3 Exploded view Electrical (second version)

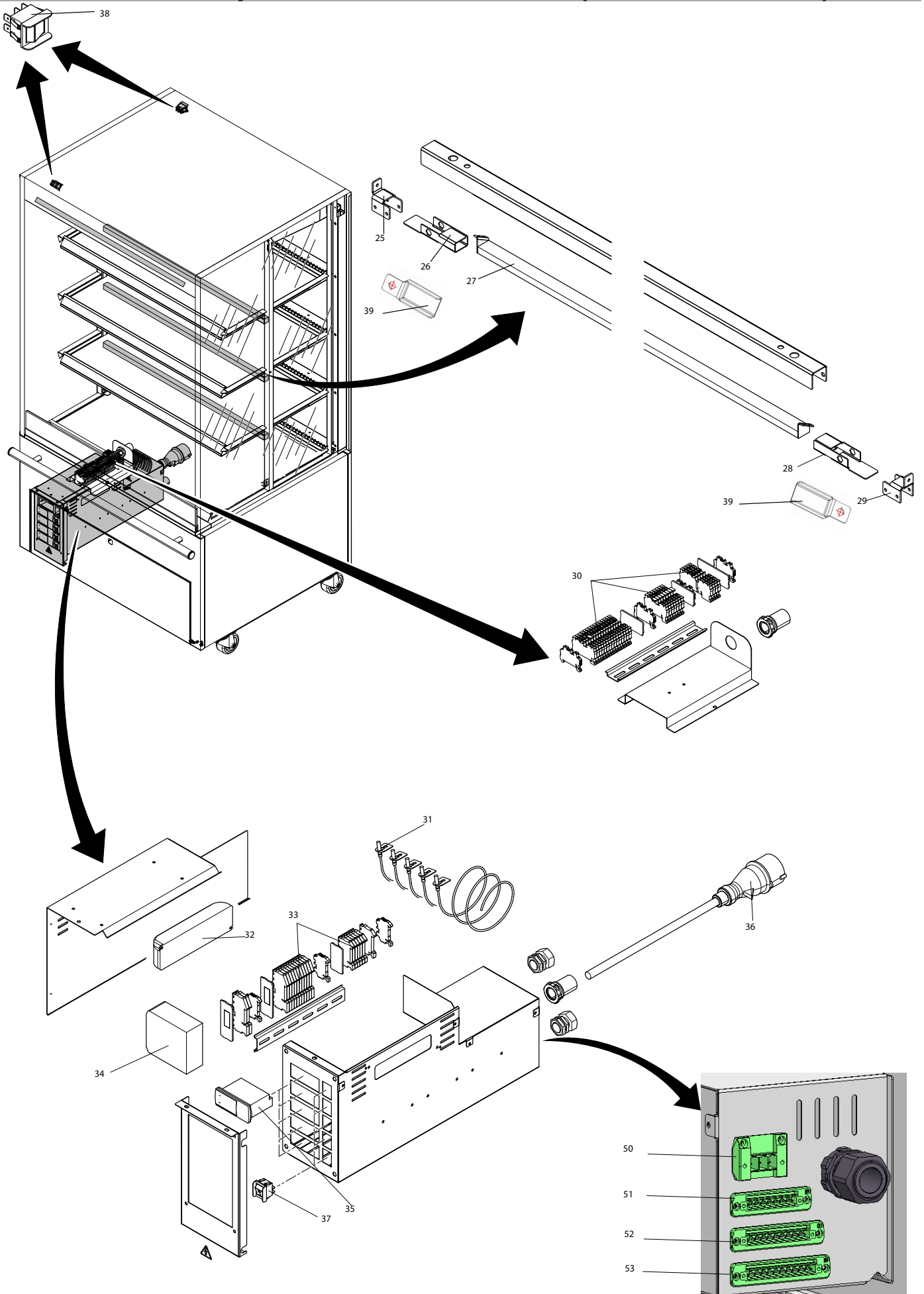

## 10.3 Exploded view Electrical (secondversion)

Number	Description	Article number	Quantity
24	Terminal PT 4 GY 4 way Terminal PT 4 GN/YE 4 way Terminal PT 4 BU	<a href="#">9191240</a> <a href="#">9191239</a> <a href="#">9191241</a>	
25	LED Armature Support Bracket Shelf	9384091	6 - 8
26	LED mounting bracket Shelf	9384093	6 - 8
27	LED MDD 60 3000k 12V 400mm LED MDD 90 3000k 12V 700mm LED MDD 120 3000k 12V 1000mm	9382075 9382067 9382068	4 - 5
28	LED mounting bracket Shelf	9384093	6 - 8
29	LED Armature Support Bracket Shelf	9384091	6 - 8
30	Terminal PT 4 GY 2 way Terminal PT 4 GN/YE 2 way	<a href="#">9191232</a> <a href="#">9191233</a>	
30	Terminal PT 4 GY 4 way Terminal PT 4 GN/YE 4 way Terminal PT 4 BU	<a href="#">9191240</a> <a href="#">9191239</a> <a href="#">9191241</a>	
31	Sensor PTC1000	<a href="#">9221011</a>	1 - 5
32	LED Driver	9381038	1
33	Terminal PT 4 GY 2 way Terminal PT 4 GN/YE 2 way	<a href="#">9191232</a> <a href="#">9191233</a>	
33	Terminal PT 4 GY 4 way Terminal PT 4 GN/YE 4 way Terminal PT 4 BU	<a href="#">9191240</a> <a href="#">9191239</a> <a href="#">9191241</a>	
34	Power supply 24V DC 40W	9381012	
35	Thermostat ERC211	<a href="#">9221109</a>	1 - 5
36	Power cord -3 layer UL 14 AWG 100" 06-20P_leads Power cord -5 layer UL 12 AWG 100" 15-30P_leads	9172401 9172404	1
37	Switch black 1-0 250V Guarded	9281036	1 - 5
38	Switch on-on 250V with guard	9391001	2
39	LED Holder Top LED	9394070	2
50	Connector		1
51	Connector		1
52	Connector		1
53	Connector		1
	Time relay 3-layer only	9391002	1

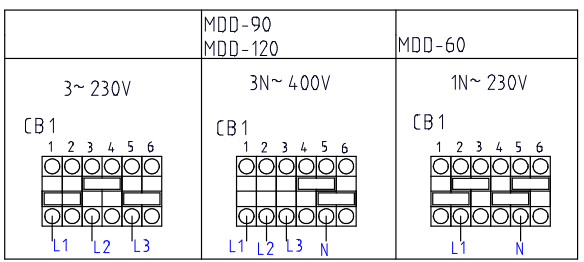
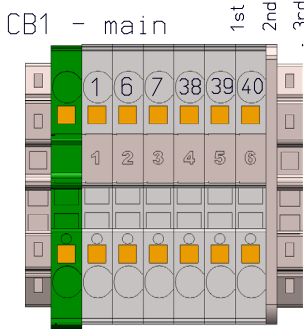
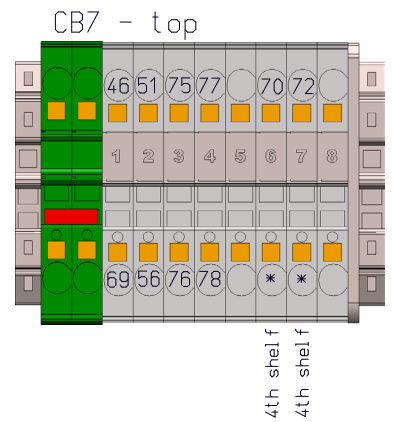
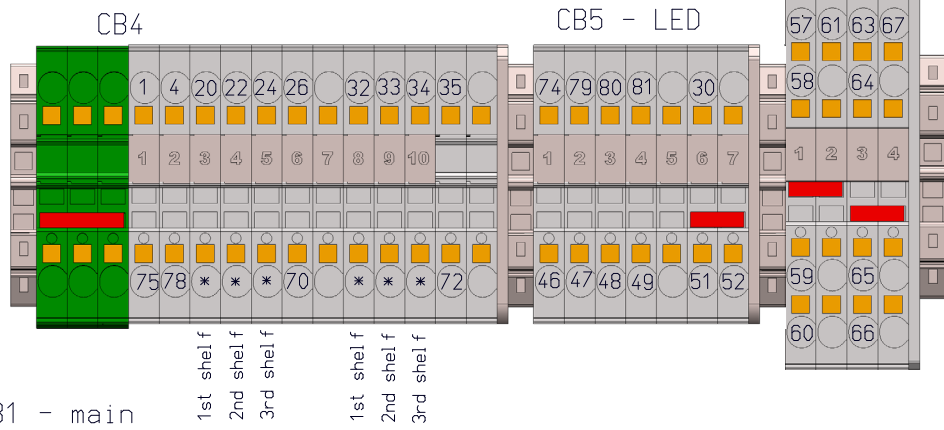
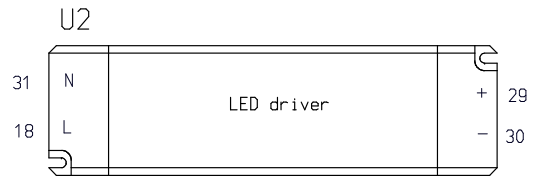
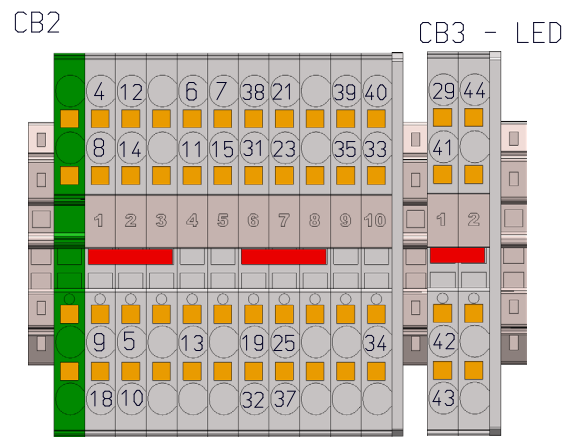
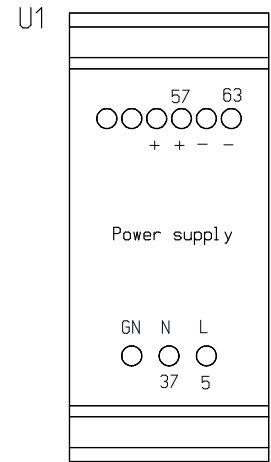
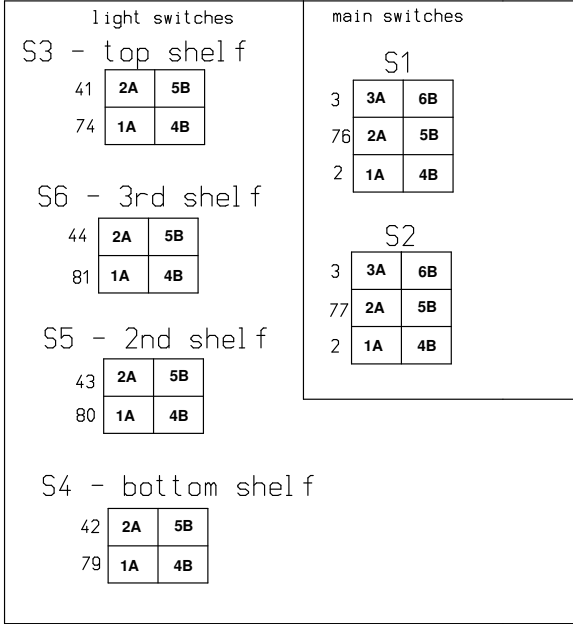
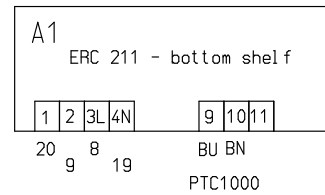
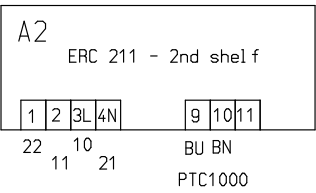
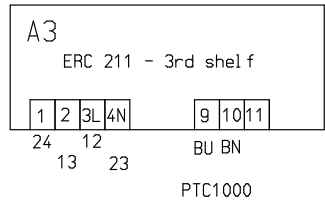
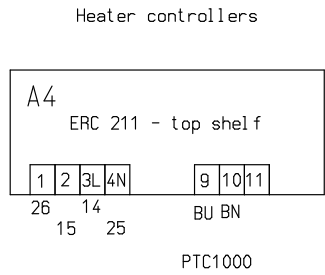

REVISION	REV. DATE	REMARK	
Tol. principle	Gen. tolerance	Surface treatment	Geom. tolerance
MATERIAL			
MATERIAL ART. NUMBER	DRAWN den Rooijen Admin	APPROVED	
UNIT mm	STATUS In Progress	DATE 12.05.2021	
SCALE 1:2	PROJECT	DRAWING NUMBER 9390812	
REMARKS			
DESCRIPTION	ART. NUMBER 9390812	REV.	SIZE A3
Wiring diagram MDD Multitemp 4 laags			

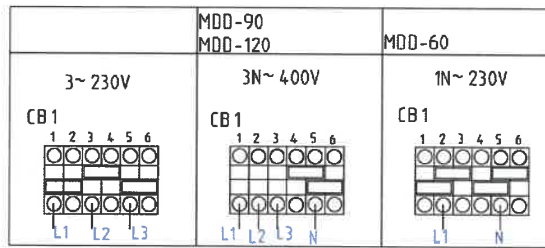
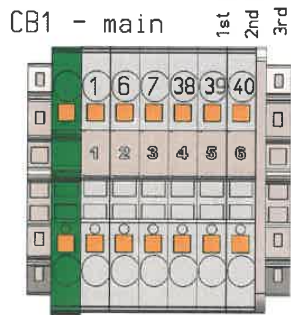
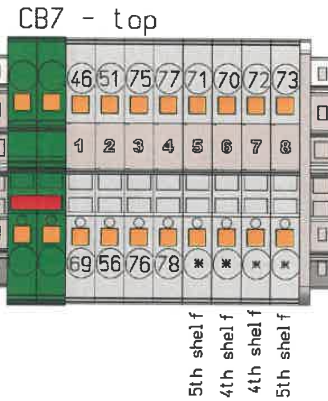
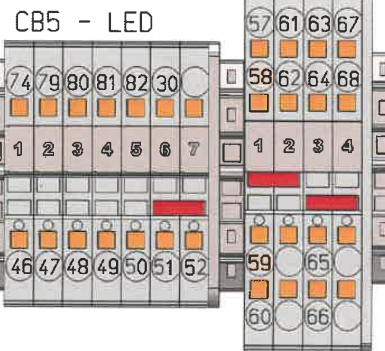
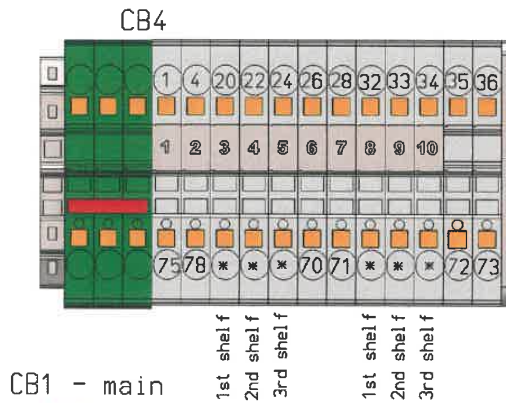
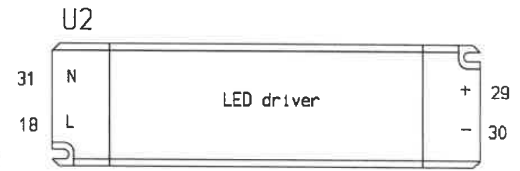
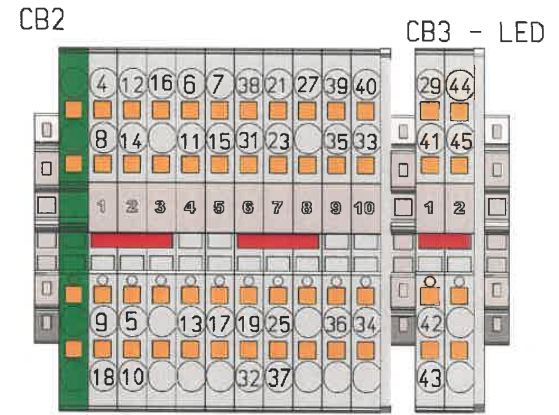
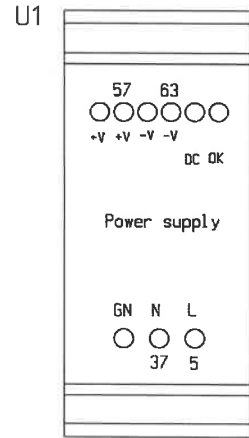
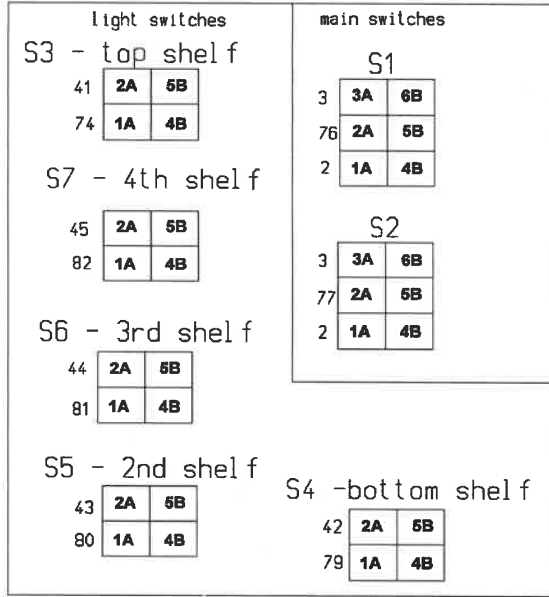
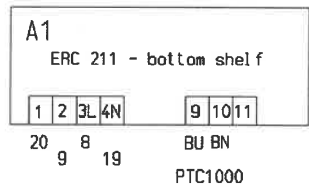
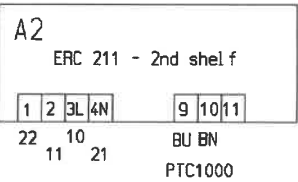
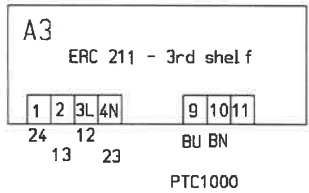
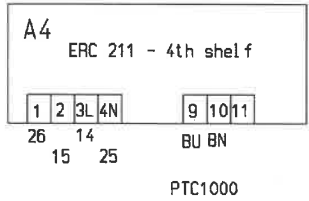
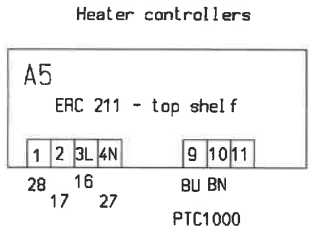

01	27.05.2021	connections U1
REVISION	REV. DATE	CONTR.
1st. structure	2nd. tolerance	3rd. placement
MATERIAL		
MATERIAL ART. NUMBER	FORN	den Rooijen Admin
UNIT	mm	In Progress
SCALE	1:2	DATE
		03.05.2021
		BOARD NUMBER
		9390811
REMARKS		
DESCRIPTION	ART. NUMBER	UNIT
Wiring diagram MDD Multitemp 5 laags	9390811	A A3

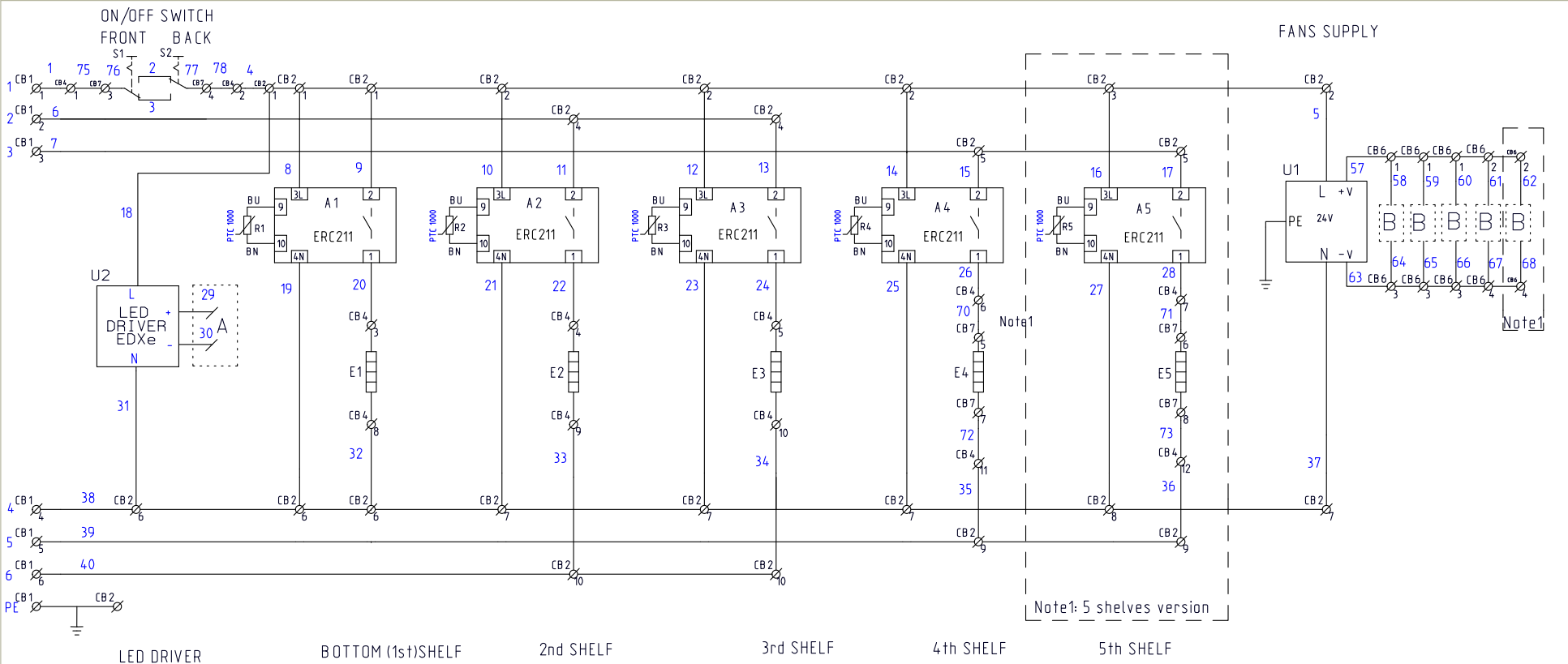

LED DRIVER

BOTTOM (1st)SHELF

2nd SHELF

3rd SHELF

4th SHELF

5th SHELF

Note1: 5 shelves version

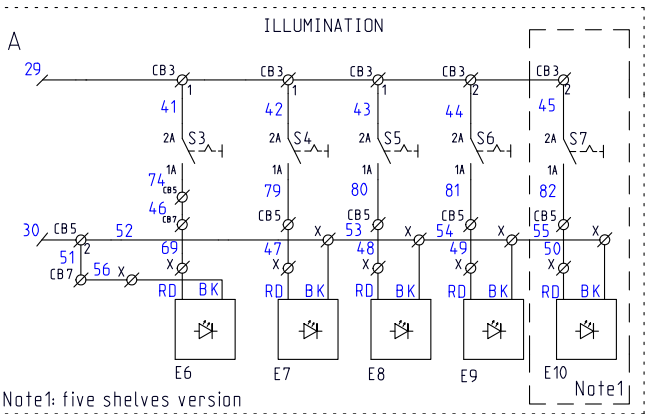

Note1: five shelves version

		MDD 120	MDD 90	MDD 60
E1	bottom shelf	1500W	1125W	750W
E2-E5	shelf 2-5	1130W	850W	570W

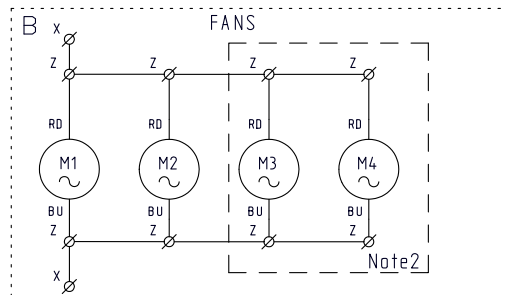

Note2: QTY DEPENDING ON WIDTH OF THE UNIT

	MDD 90 MDD 120	MDD 60
3~ 230V	3N~ 400V	1N~ 230V

REVISION	REV. DATE	REMARK
Tol. principle		Gen. tolerance
		Surface treatment
		Geom. tolerance
MATERIAL		
MATERIAL ART. NUMBER	DRAWN den Rooijen Admin	APPROVED
UNIT mm	STATUS In Progress	DATE 28.04.2021
SCALE 1: 1	PROJECT 939	DRAWING NUMBER 9390810
REMARKS DESCRIPTION		
Circuit diagram MDD MT		ART. NUMBER 9390810
	REV.	SIZE A3

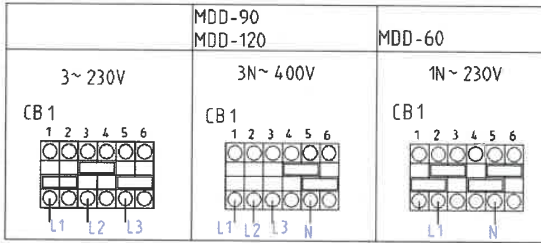
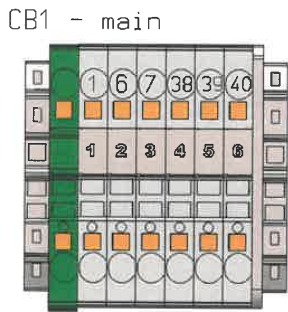
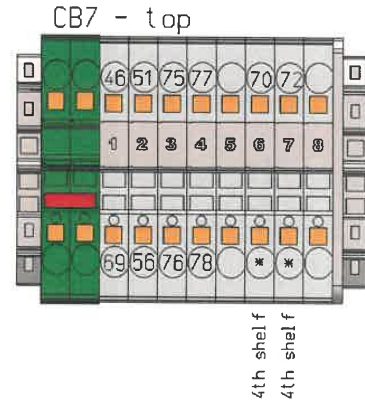
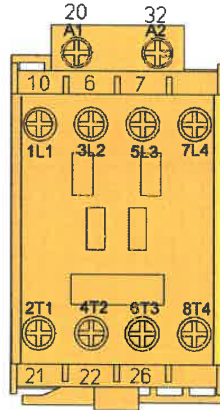
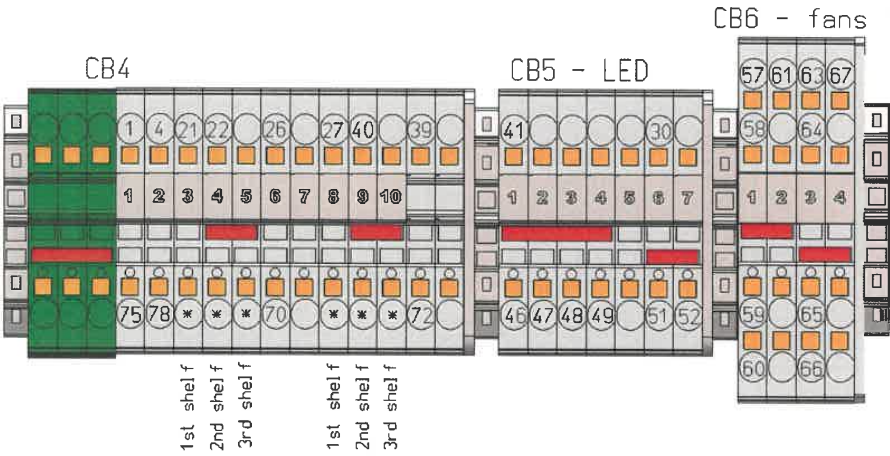
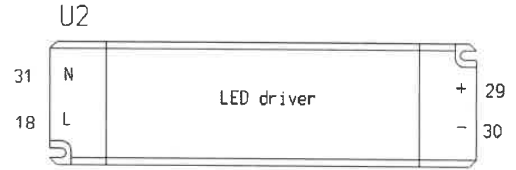
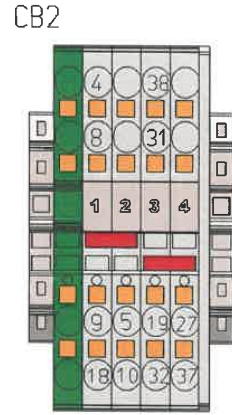
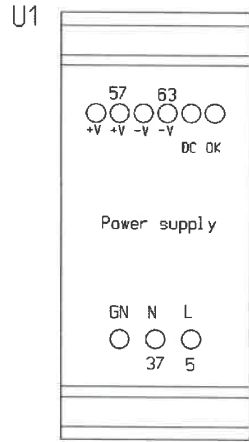
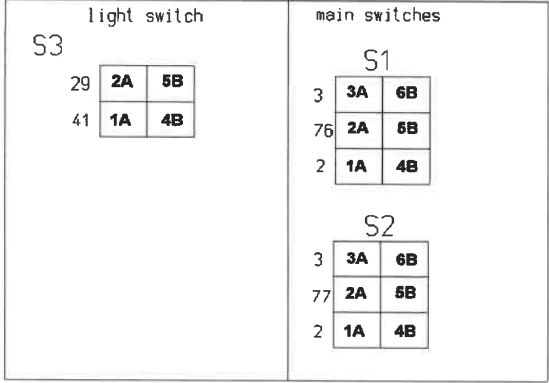
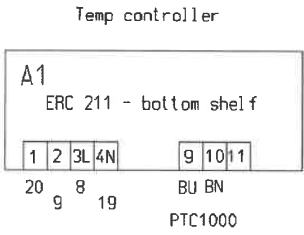

den Rooijen Admin  
In Progress  
17.05.2021  
9390802

mm 1:2  
9390802

Wiring diagram MDD Singletemp 4 laags 9390802 A3

11.3 Electrical schematic wiring Single Temp 4 layer I

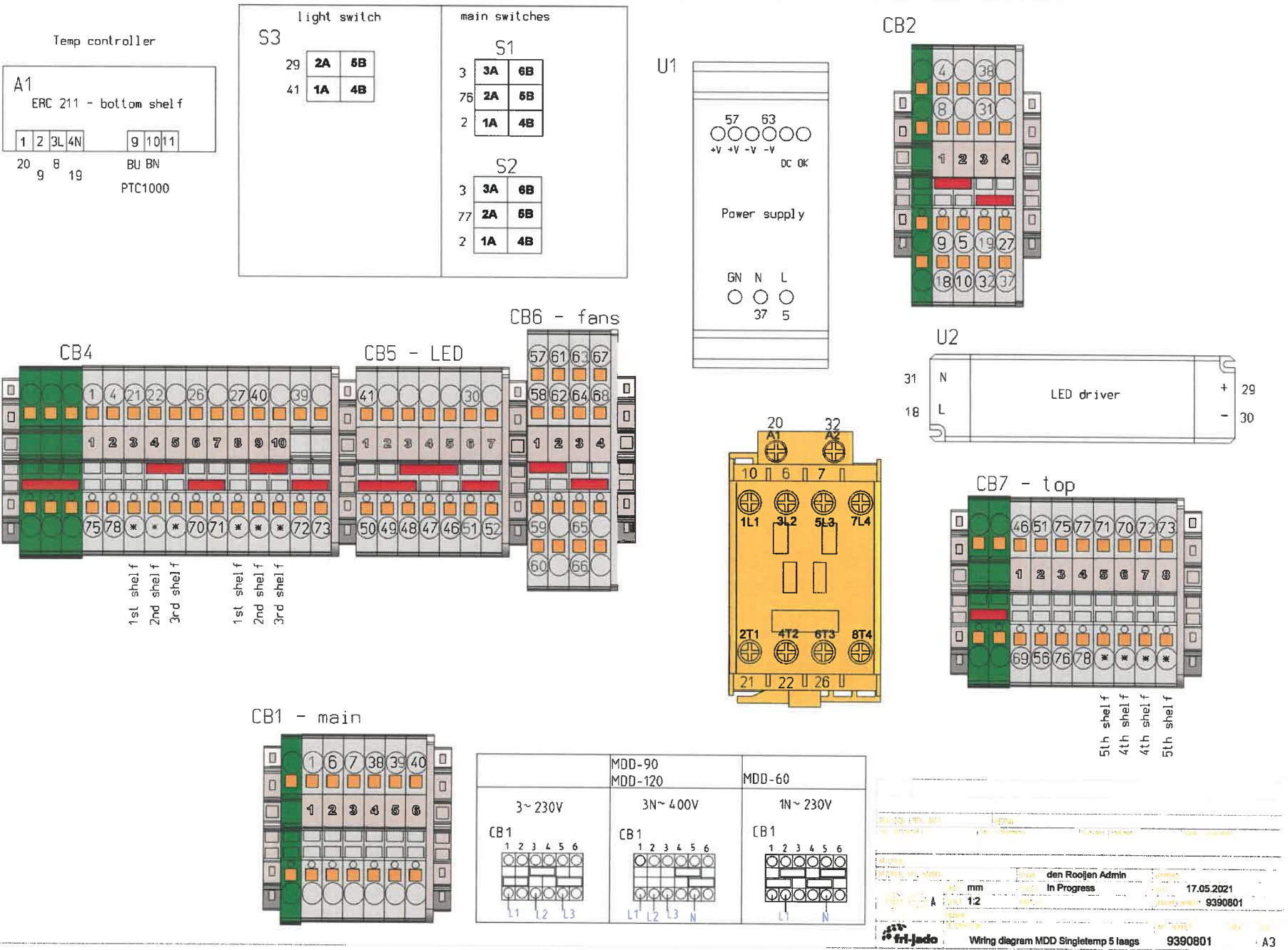

DATE: 17.05.2021	STATUS: In Progress	PROJECT: 9390801
DESIGNER: den Rooijen Admin	DATE: 17.05.2021	PROJECT: 9390801
SCALE: 1:1	UNIT: mm	PROJECT: 9390801
fri-jado		
Wiring diagram MDD Singletemp 5 laags		
		9390801
		A3

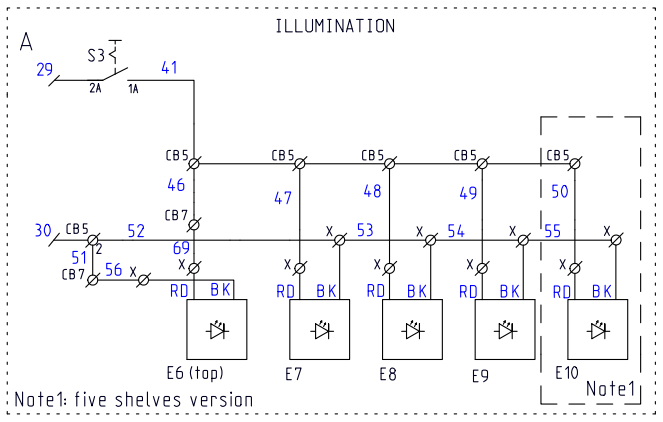
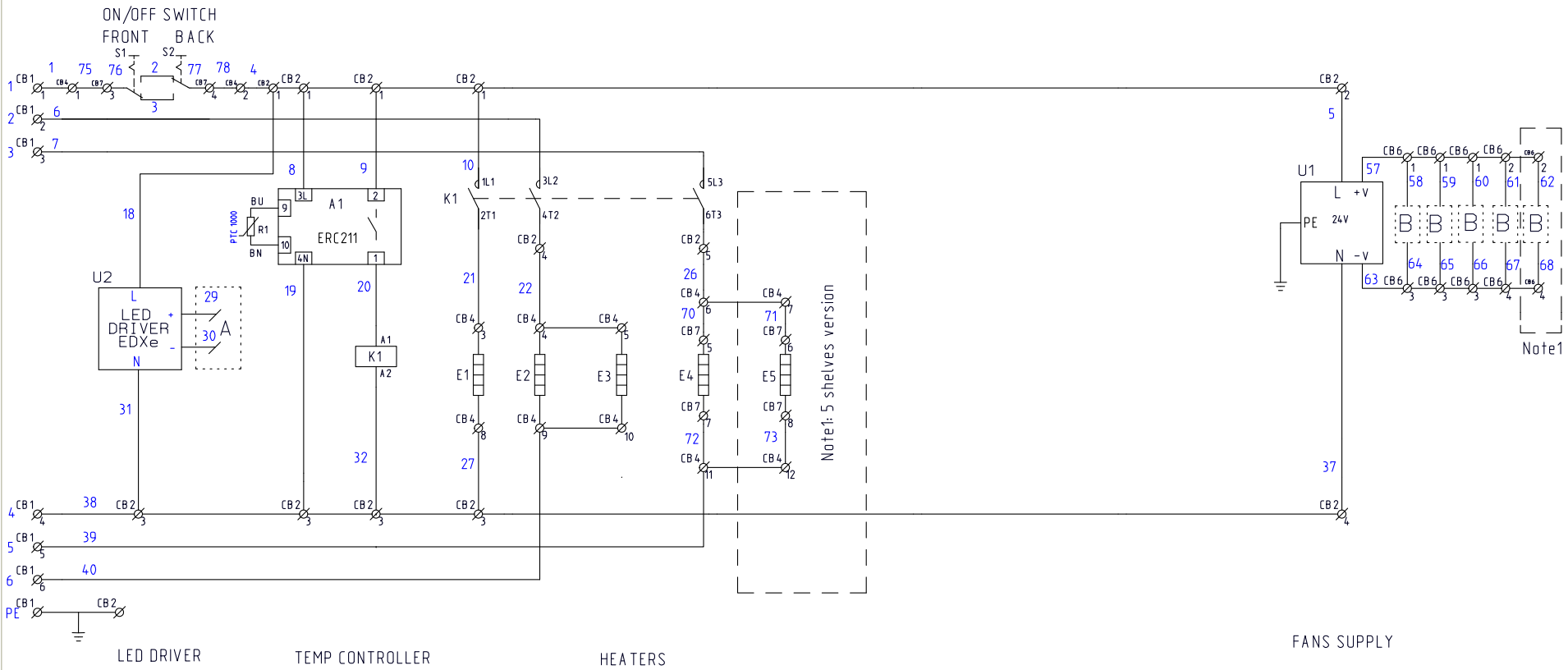

		MDD 120	MDD 90	MDD 60
E1	bottom shelf	1500W	1125W	750W
E2-E5	shelf 2-5	1130W	850W	570W

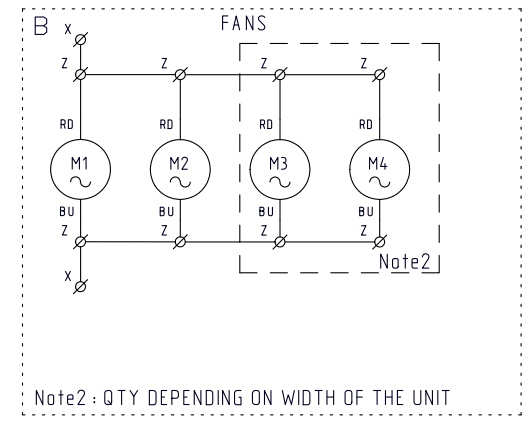

	MDD 90	MDD 60
3~ 230V	3N~ 400V	1N~ 230V

REVISION	REV. DATE	REMARK
Tot. principle		Gen. Tolerance Surface treatment Geom. Tolerance
MATERIAL		
MATERIAL ART. NUMBER	DRAWN den Rooijen Admin	APPROVED
UNIT mm	STATUS In Progress	DATE 12.05.2021
SCALE 1:1	PROJECT 939	DRAWING NUMBER 9390800
REMARKS DESCRIPTION		
Circuit diagram MDD ST		ART. NUMBER 9390800
	REV.	SIZE A3

11.5 Electrical schematic circuit Single Temp I



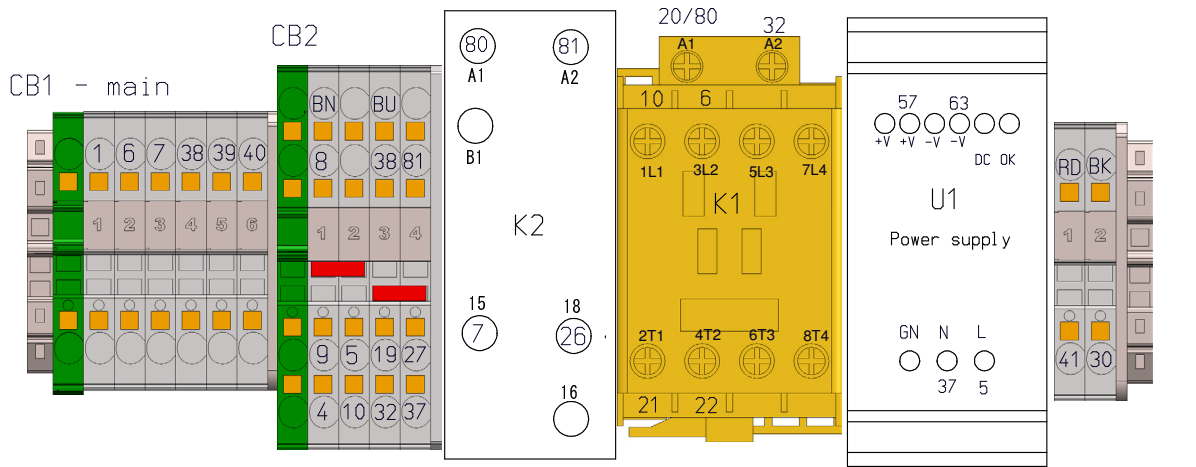
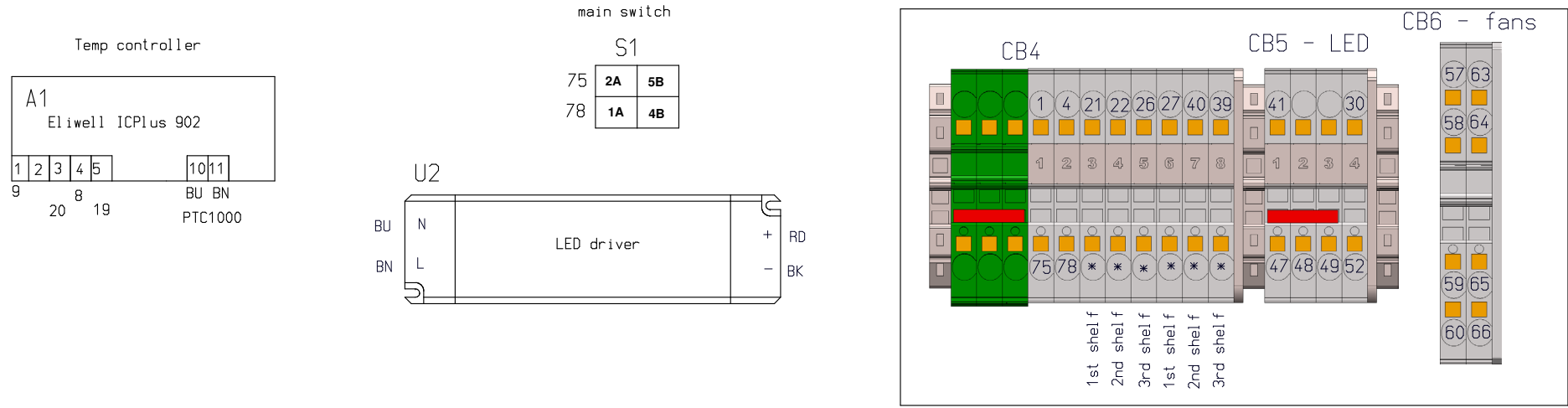

MDD-48 208V	MDD-120	MDD-36 208V MDD-24 208V MDD-90 MDD-60
3~ 230V 3~ 208V	3N~ 400V	1N~ 230V 1~ 208V
L1 L2 L3 BK WH RD	L1 L2 L3 N BN BK GY BU	L1 N BN BU

Timerelais values

	MDD 60	MDD 90	MDD 120
K2	50s	90s	150s

04	18.05.2022	lay out change
03	07.04.2022	timerelais
REVISION	REV. DATE	REMARK
Tol. principle	Gen. tolerance	Surface treatment
		Geom. tolerance
MATERIAL		
MATERIAL ART. NUMBER	DRAWN den Rooijen Admin	APPROVED
UNIT mm	STATUS In Progress	DATE 25.11.2021
SCALE 1:2	PROJECT	DRAWING NUMBER 9390803
REMARKS		
DESCRIPTION		
Wiring diagram MDD Single temp 3 laags		ART. NUMBER 9390803
REV. D	SIZE A3	

## 12.0.1 Electrical schematic wiring 3 layer remark concerning Time relay.



**Replacement Time relay in case of time relay failure.**

In case a time relay need to be replaced, please change position of relay on Din rail as seen below.

### Existing situation

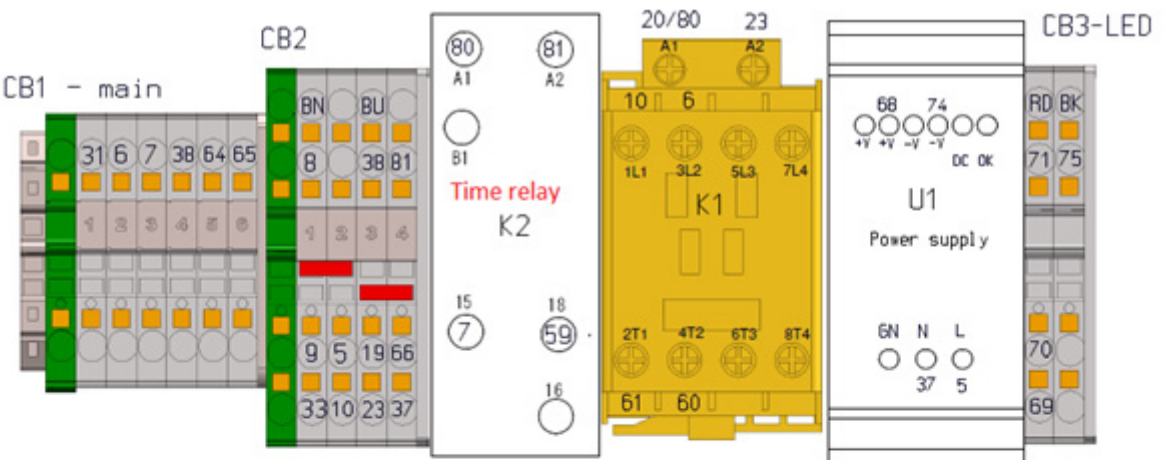

### New Situation

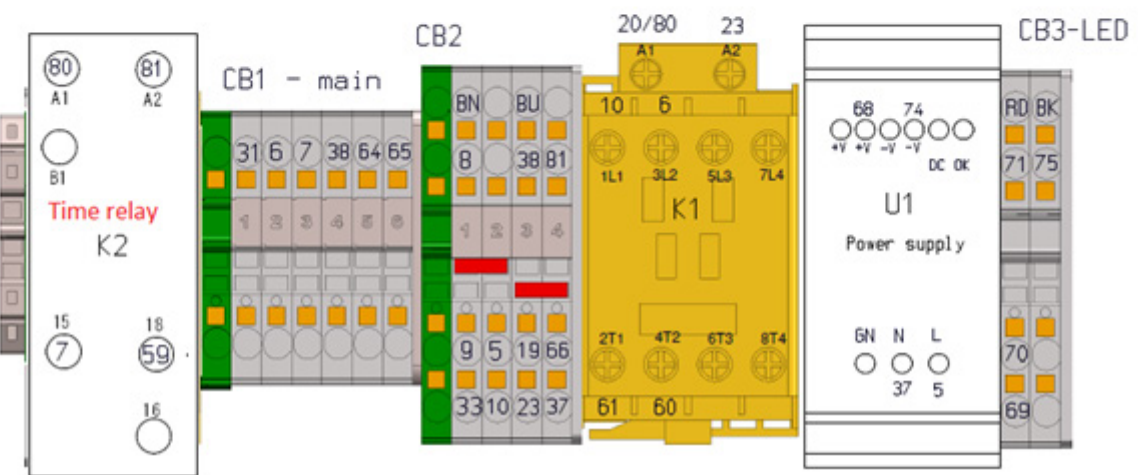

	MDD 60	MDD 90	MDD 120
K2	50s	90s	150s

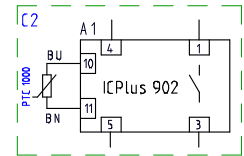
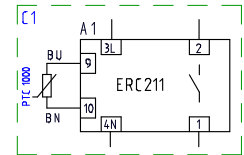
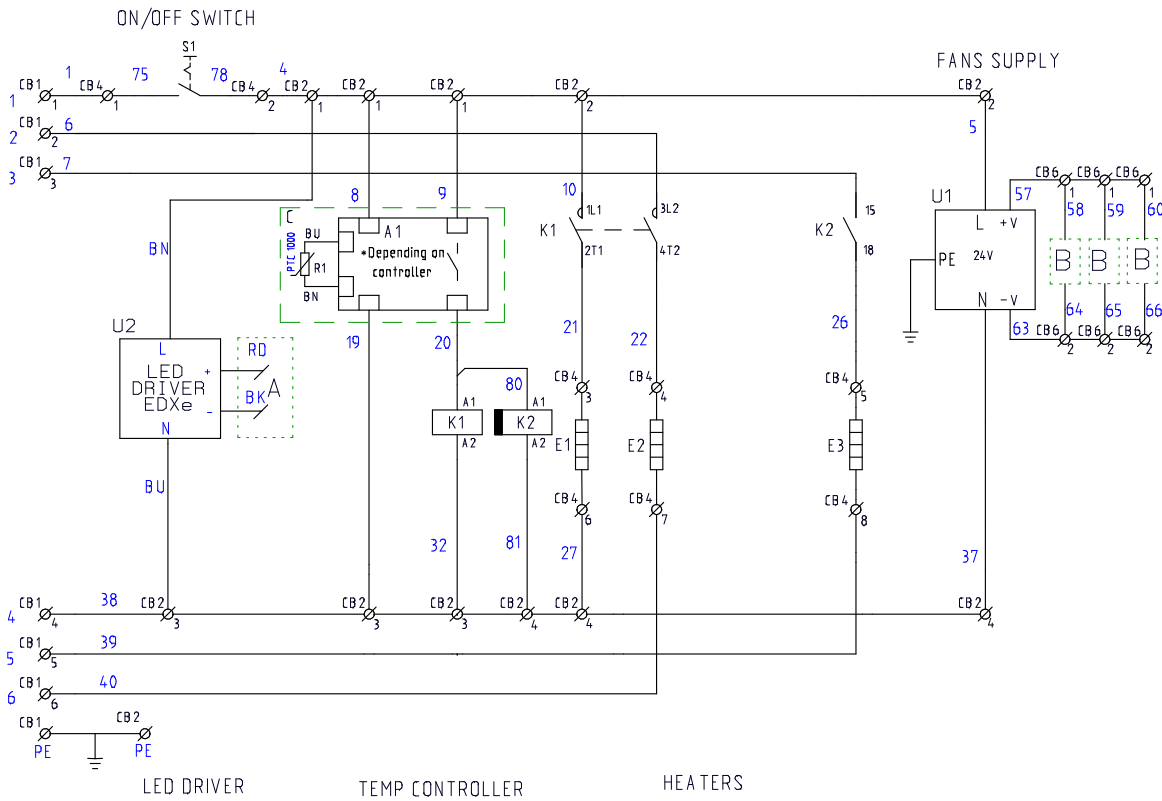

		MDD 60	MDD 90	MDD 120
E1	bottom shelf	750W	1125W	1500W
E2-E3	shelf 2-3	650W	850W	1130W

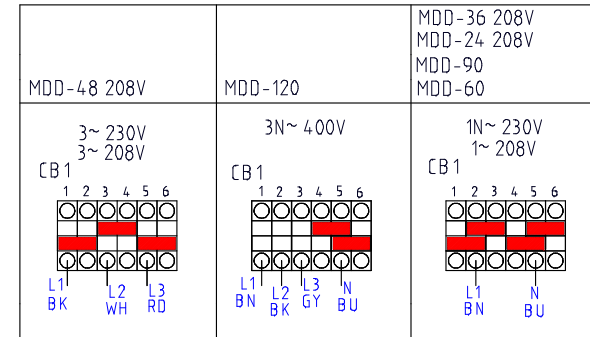

03	07.04.2022	timerelais values
02	21.01.2022	Eliwell VDH
REVISION	REV. DATE	REMARK
Tol. principle	Gen. tolerance	Surface treatment
Geom. tolerance		
MATERIAL		
MATERIAL ART. NUMBER	DRAWN den Rooijen Admin	APPROVED
UNIT mm	STATUS In Progress	DATE 25.11.2021
SCALE 1:1	PROJECT	DRAWING NUMBER 9390804
REMARKS		
DESCRIPTION	ART. NUMBER	REV. SIZE
Circuit diagram MDD ST 3	9390804	C A3

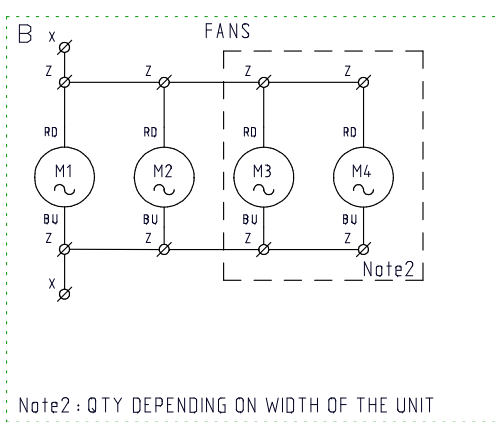
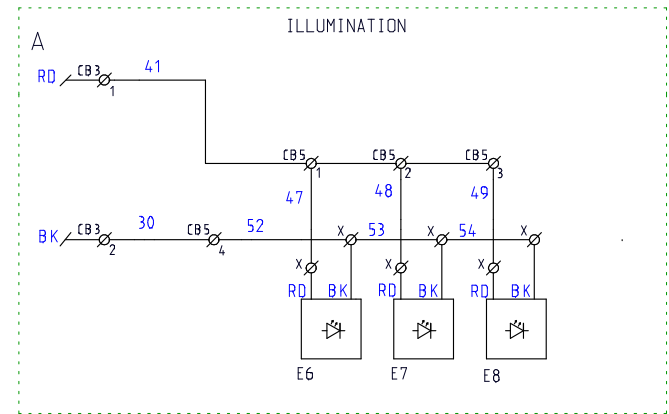



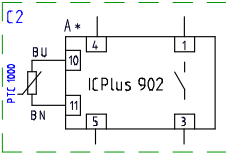
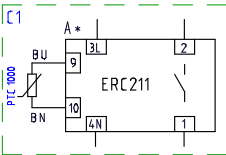
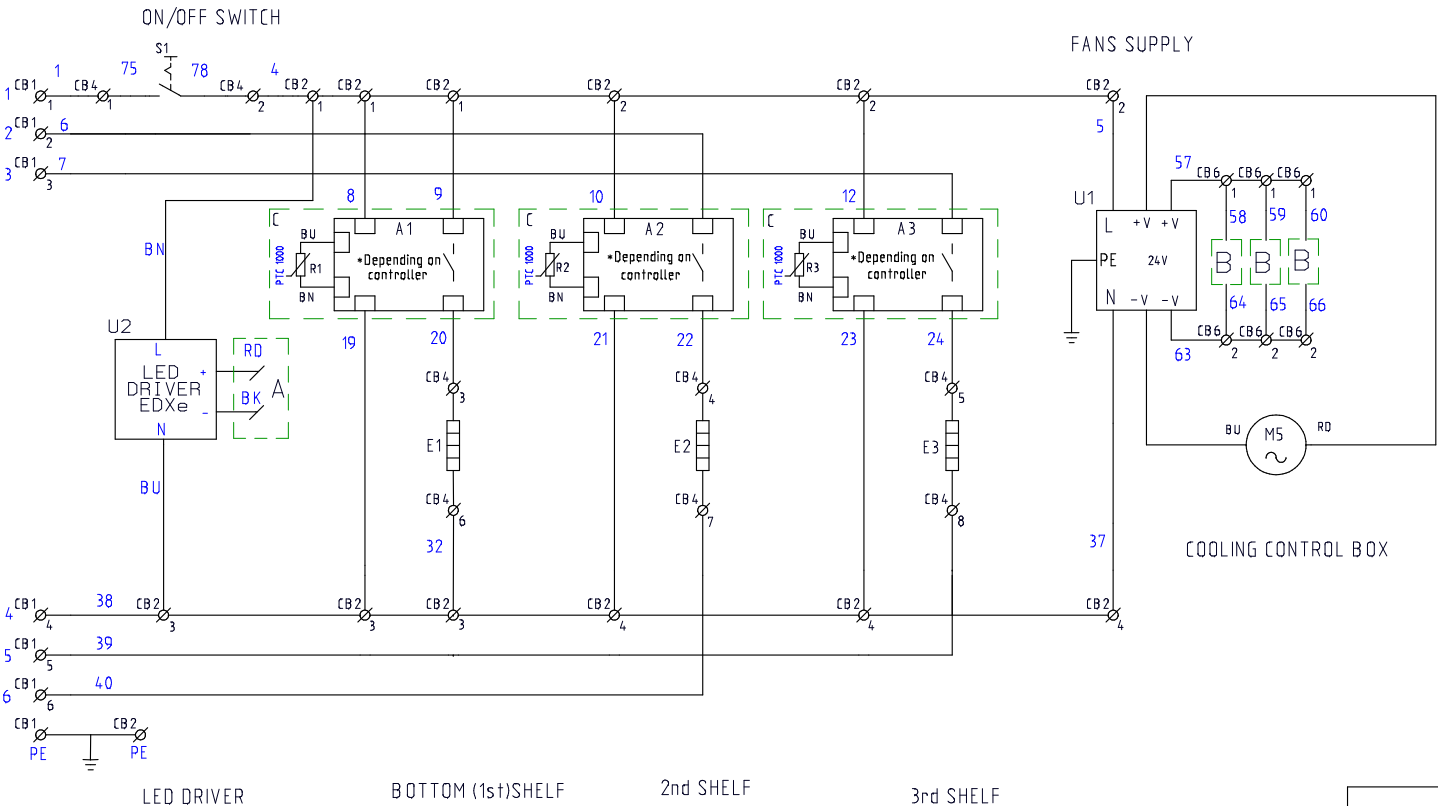

		MDD 60	MDD 90	MDD 120
E1	bottom shelf	750W	1125W	1500W
E2-E3	shelf 2-3	650W	850W	1130W

MDD-48 208V	MDD-120	MDD-36 208V MDD-24 208V MDD-90 MDD-60
3~ 230V 3~ 208V	3N~ 400V	1N~ 230V 1~ 208V

02	21.01.2022	Eliwell VDH	
01	16.12.2021	small changes	
REVISION	REV. DATE	REMARK	
Tol. principle	Gen. tolerance	Surface treatment	
Geom. tolerance			
MATERIAL			
MATERIAL ART. NUMBER	DRAWN den Rooijen Admin	APPROVED	
UNIT mm	STATUS In Progress	DATE 25.11.2021	
SCALE 1:1	PROJECT	DRAWING NUMBER 9390809	
REMARKS	DESCRIPTION	ART. NUMBER	
		REV.	
		SIZE	
Circuit diagram MDD MT 3		9390809	B A3

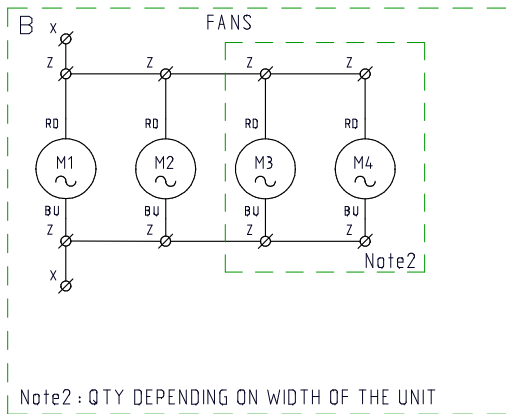
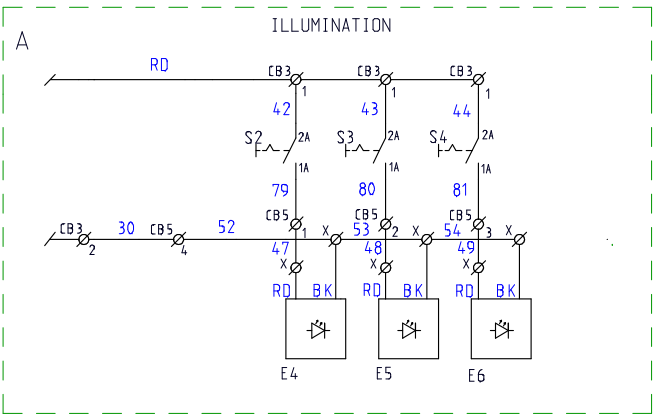

Temp controller

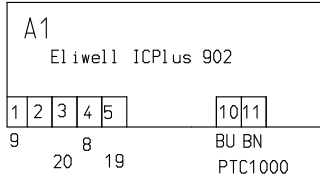

main switches

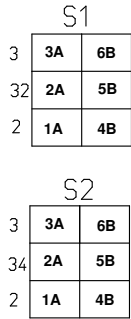

U1

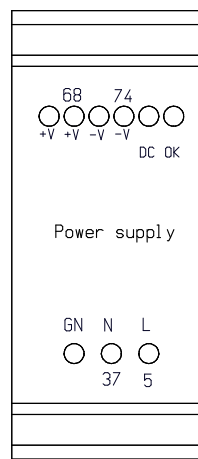

CB2

CB3 - LED

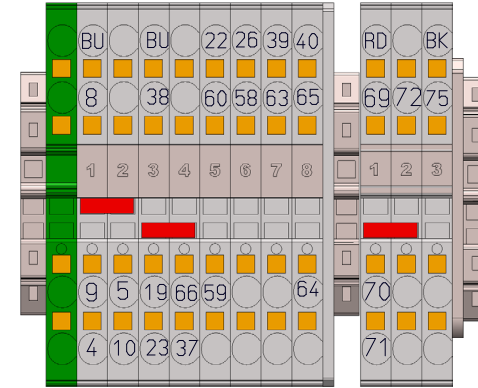

U2

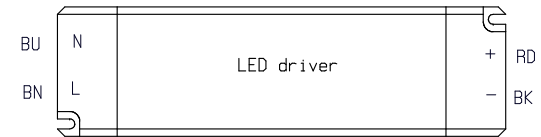

main switch

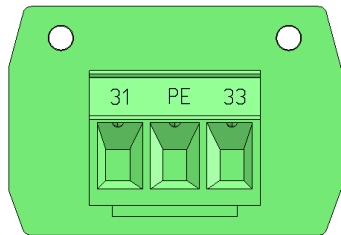

fan+led

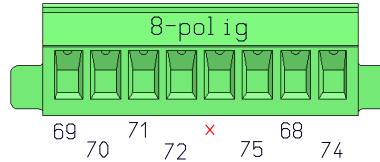

elements

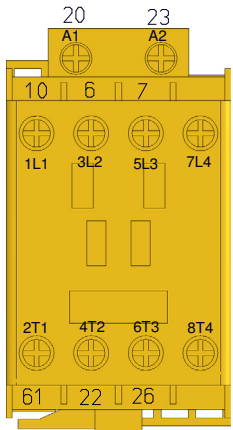
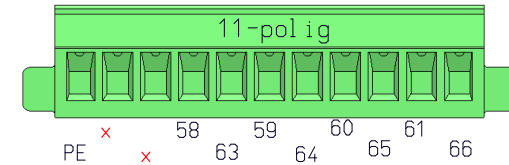

CB1 - main

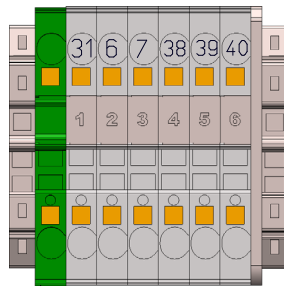

MDD-36 208V MDD-48 208V	MDD-60-5 MDD-90 MDD-120	MDD-24 208V MDD-60-4
3~ 230V 3~ 208V	3N~ 400V	1N~ 230V 1~ 208V

06	27.06.2022	batch elec update
05	05.05.2022	update
REVISION	REV. DATE	REMARK
Tol. principle	Gen. tolerance	Surface treatment
		Geom. tolerance
MATERIAL		
MATERIAL ART. NUMBER	DRAWN den Rooijen Admin	APPROVED
UNIT mm	STATUS In Progress	DATE 17.05.2021
SCALE 1:2	PROJECT	DRAWING NUMBER 9390802
REMARKS		
DESCRIPTION		
Wiring diagram MDD Singletemp 4 laags		ART. NUMBER 9390802
REV. F	SIZE A3	

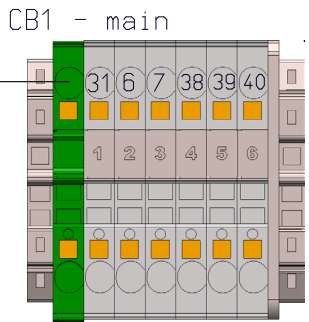
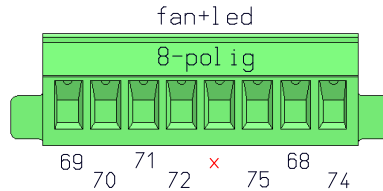
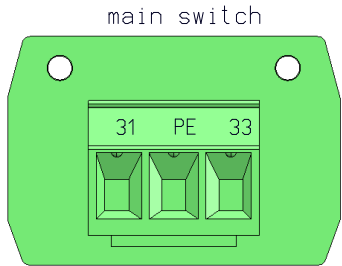
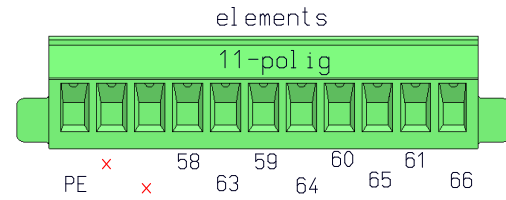
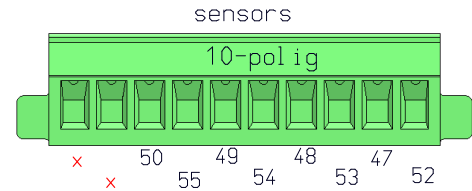
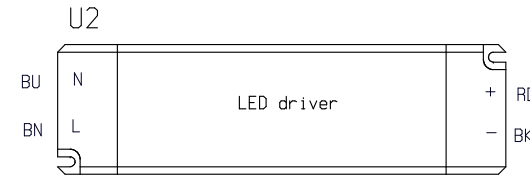
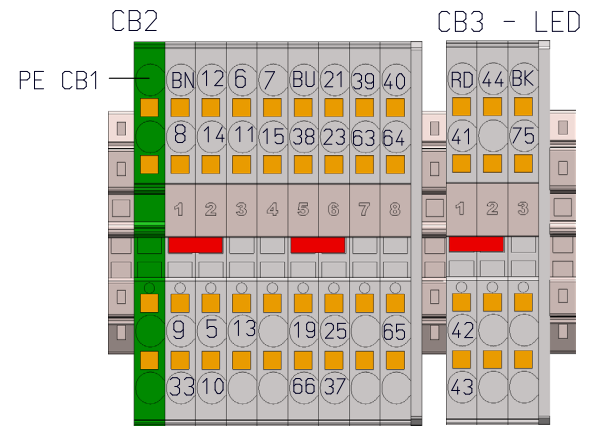
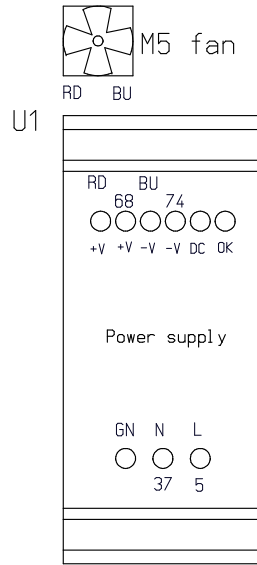
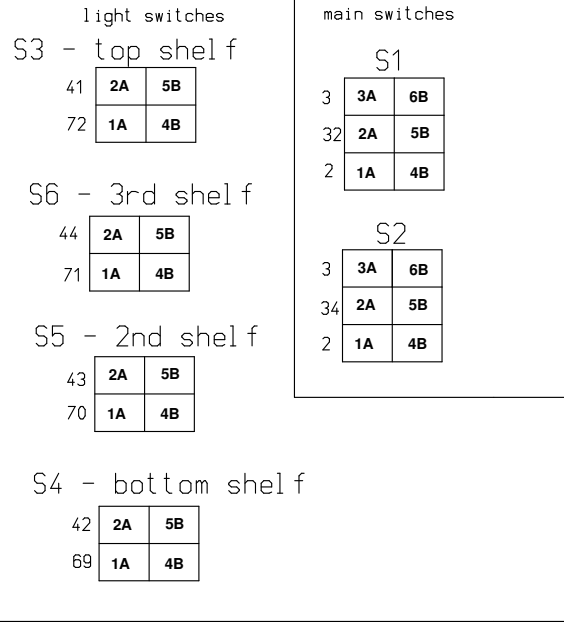
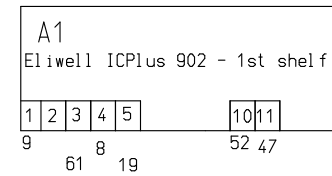
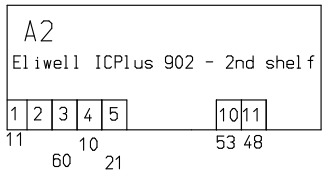
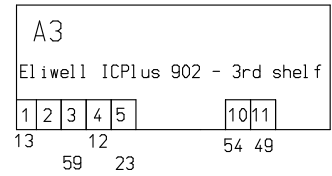
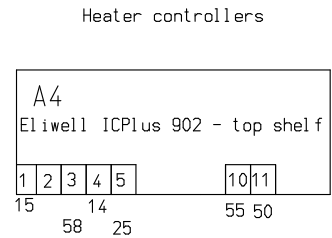

MDD-36 208V MDD-48 208V	MDD-60-5 MDD-90 MDD-120	MDD-24 208V MDD-60-4
3~ 230V 3~ 208V	3N~ 400V	1N~ 230V 1~ 208V
<p>CB1</p>	<p>CB1</p>	<p>CB1</p>

09	27.06.2022	batch elec update
08	05.05.2022	update
REVISION	REV. DATE	REMARK
Tot. principle		Gen. tolerance
		Surface treatment
		Geom. Tolerance
MATERIAL		
MATERIAL ART. NUMBER	DRAWN den Rooijen Admin	APPROVED
UNIT mm	STATUS In Progress	DATE 12.05.2021
SCALE 1:2	PROJECT	DRAWING NUMBER 9390812
REMARKS DESCRIPTION		
Wiring diagram MDD Multitemp 4 laags		ART. NUMBER 9390812
REV. I	SIZE A3	

Temp controller

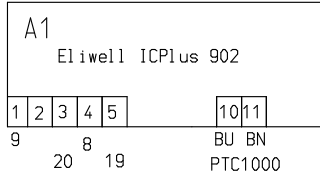

main switches

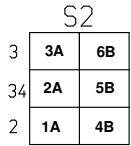
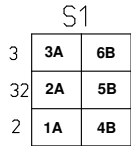

U1

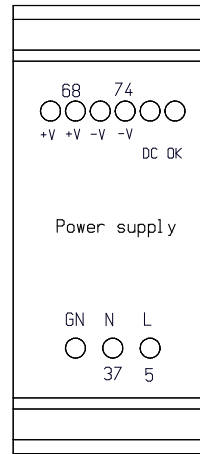

CB2

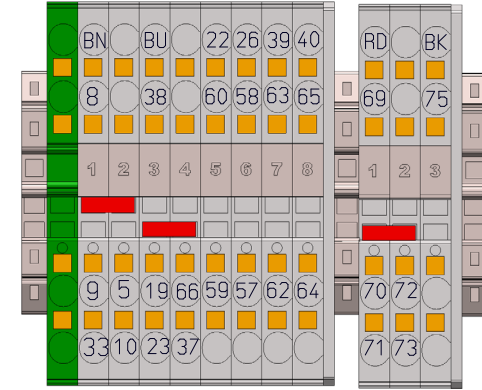

U2

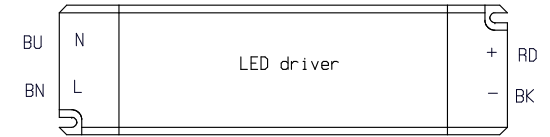

main switch

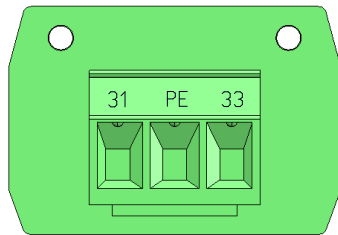

fan+led

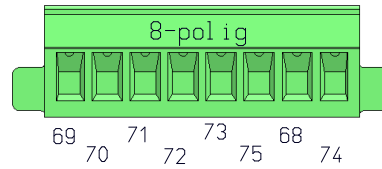

elements

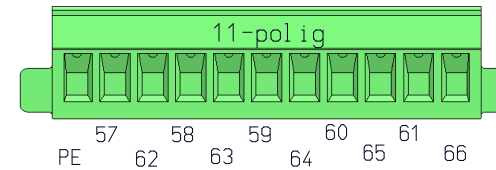

CB1 - main

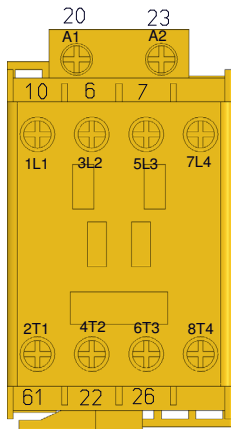
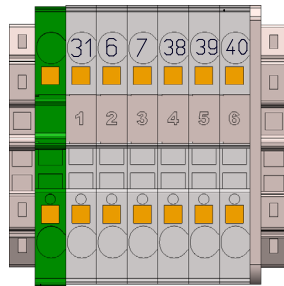

MDD-36 208V MDD-48 208V	MDD-60-5 MDD-90 MDD-120	MDD-24 208V MDD-60-4
3~ 230V 3~ 208V	3N~ 400V	1N~ 230V 1~ 208V
CB1	CB1	CB1
L1 BK, L2 WH, L3 RD	L1 BN, L2 BK, L3 GY, N BU	L1 BN, N BU

06	27.06.2022	batch elec update
05	05.05.2022	update
REVISION	REV. DATE	REMARK
Tol. principle	Gen. Tolerance	Surface treatment
Gen. Tolerance		
MATERIAL		
MATERIAL ART. NUMBER	DRAWN den Rooijen Admin	APPROVED
UNIT mm	STATUS In Progress	DATE 17.05.2021
SCALE 1:2	PROJECT	DRAWING NUMBER 9390801
REMARKS		
DESCRIPTION		ART. NUMBER
Wiring diagram MDD Single temp 5 laags		9390801
REV.	SIZE	
F	A3	

Heater controllers

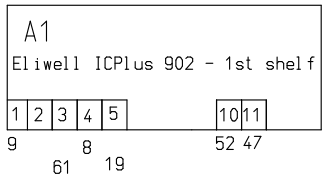
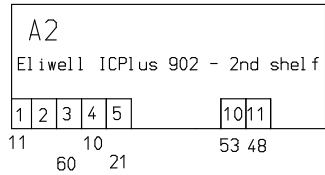
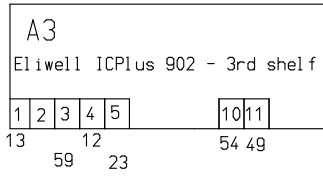
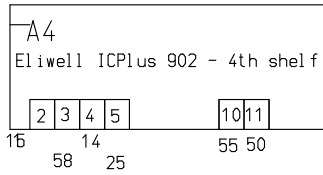
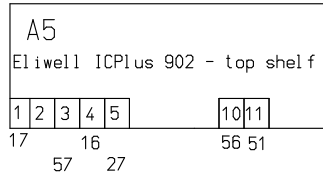

light switches

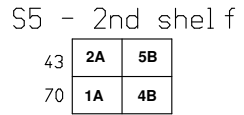
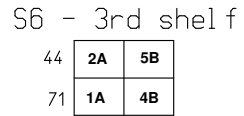
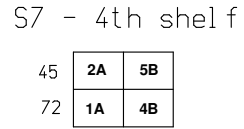
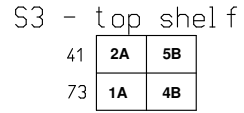

main switches

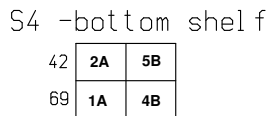
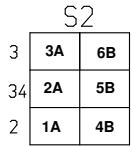
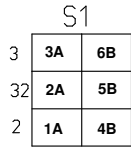

main switch

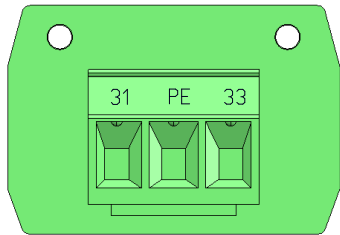

fan+led

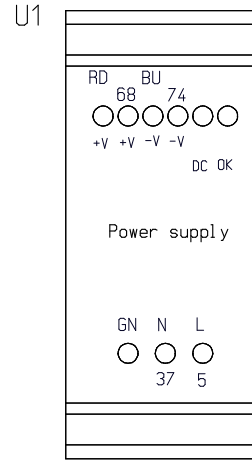
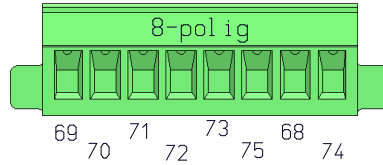

CB2

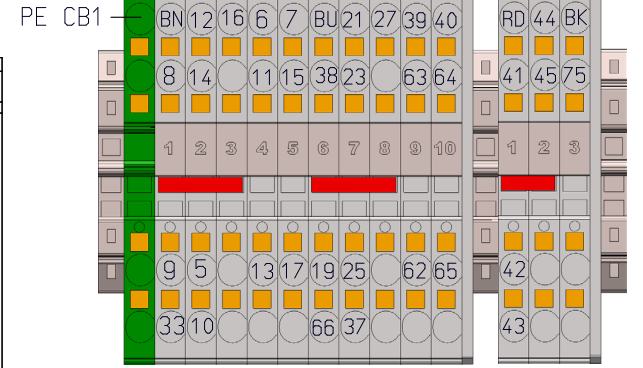

CB3 - LED

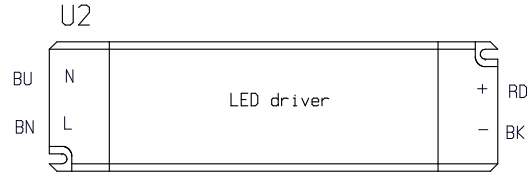

sensors

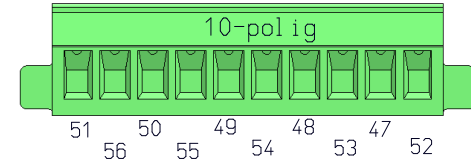

elements

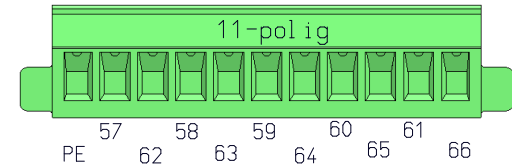

MDD-36 208V MDD-48 208V	MDD-60-5 MDD-90 MDD-120	MDD-24 208V MDD-60-4
3~ 230V 3~ 208V	3N~ 400V	1N~ 230V 1~ 208V
<p>CB1</p>	<p>CB1</p>	<p>CB1</p>
L1 BK L2 WH L3 RD	L1 BN L2 BK L3 GY N BU	L1 BN N BU

08	27.06.2022	batch elec update
07	05.05.2022	update
REVISION	REV. DATE	REMARK
Tol. principle	Gen. tolerance	Surface treatment
MATERIAL		
MATERIAL ART. NUMBER	DRAWN den Rooijen Admin	APPROVED
UNIT mm	STATUS In Progress	DATE 03.05.2021
SCALE 1: 2	PROJECT	DRAWING NUMBER 9390811
REMARKS		
DESCRIPTION	ART. NUMBER	REV. SIZE
Wiring diagram MDD Multitemp 5 laags	9390811	H A3

12.7 Electrical schematic wiring Multi Temp 5 layer II



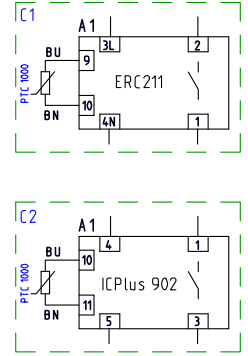
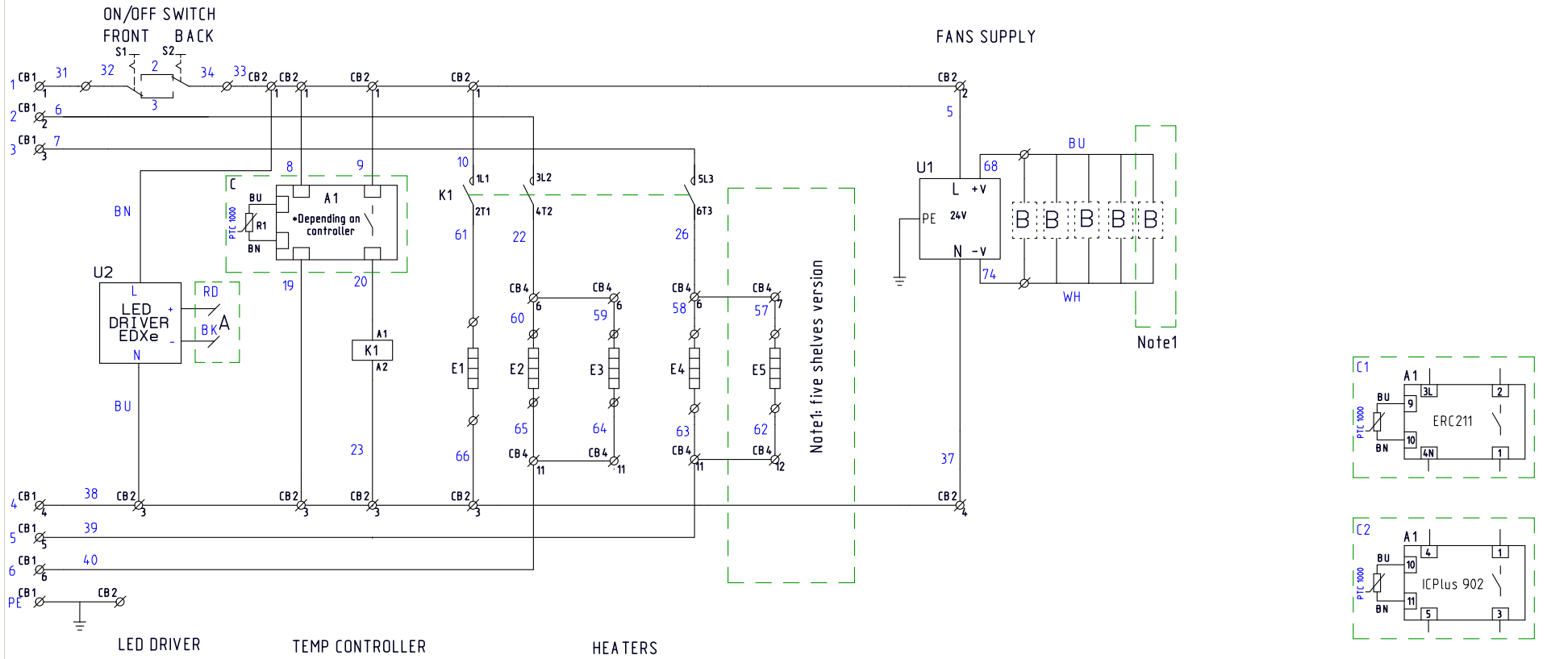

		MDD 120	MDD 90	MDD 60
E1	bottom shelf	1500W	1125W	750W
E2-E5	shelf 2-5	1130W	850W	650W

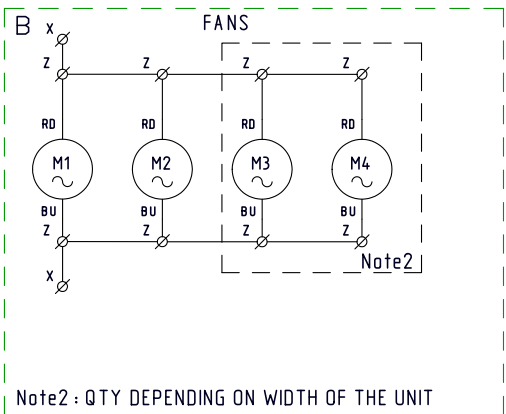
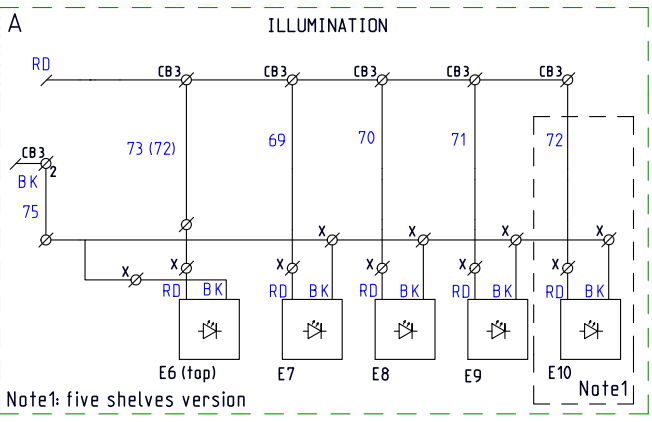

MDD 36 208V MDD 48 208V 3~ 230V 3~ 208V	MDD 60-5 230V MDD 90 230V MDD 120 230V 3N~ 400V	MDD 24 208V MDD 60-4 230V 1N~ 230V 1~ 208V

05	27.06.2022	batch elec update
04	05.05.2022	update
REVISION	REV. DATE	REMARK
Tol. principle	Gen. tolerance	Surface Treatment
		Geom. tolerance
MATERIAL		
MATERIAL ART. NUMBER	DRAWN den Rooijen Admin	APPROVED
UNIT mm	STATUS In Progress	DATE 12.05.2021
SCALE 1:1	PROJECT 939	DRAWING NUMBER 9390800
REMARKS		
DESCRIPTION	Circuit diagram MDD ST 4-5	ART. NUMBER 9390800
		REV. E
		SIZE A3



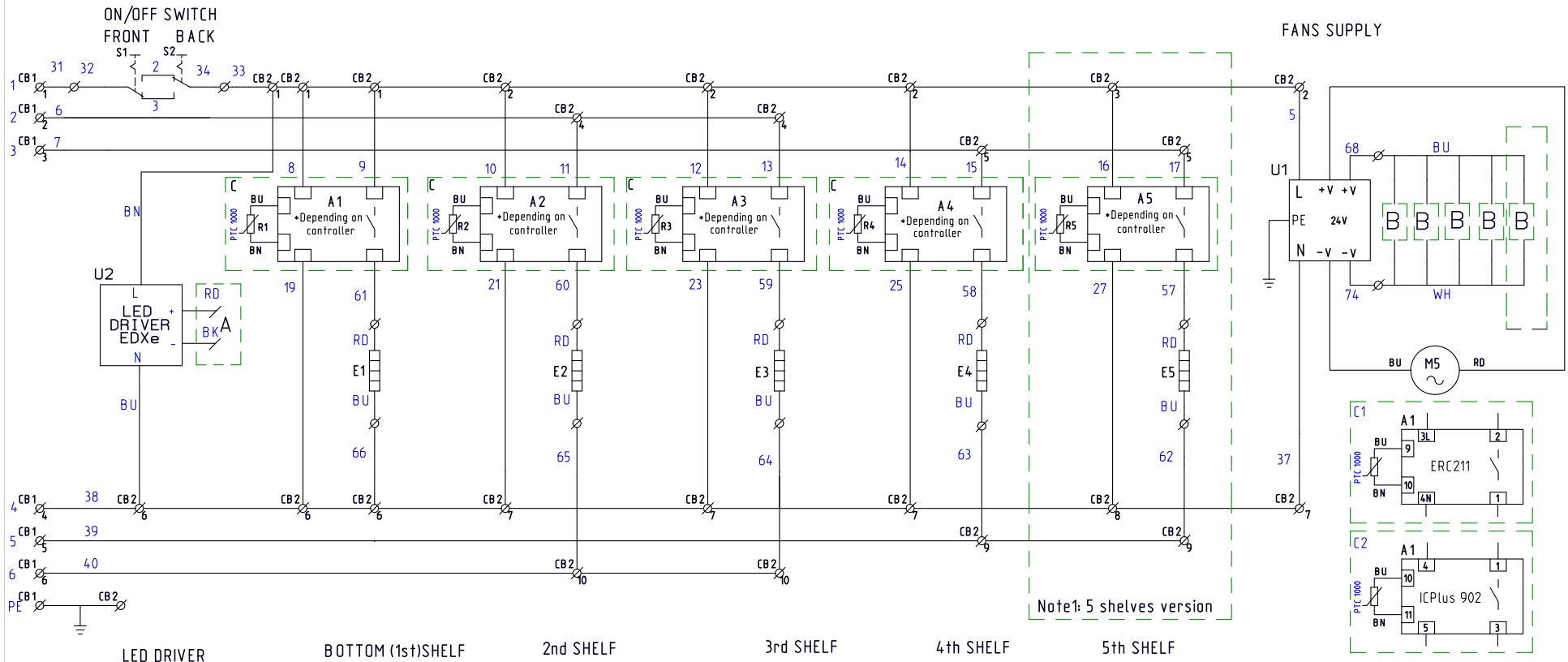

Note1: 5 shelves version

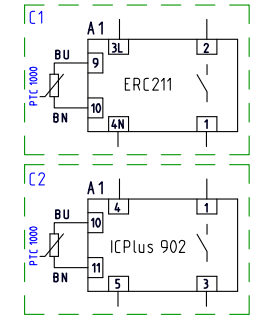

		MDD 120	MDD 90	MDD 60
E1	bottom shelf	1500W	1125W	750W
E2-E5	shelf 2-5	1130W	850W	650W

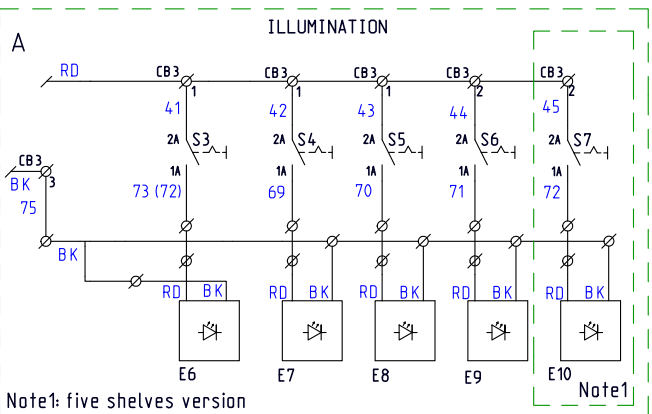

Note1: five shelves version

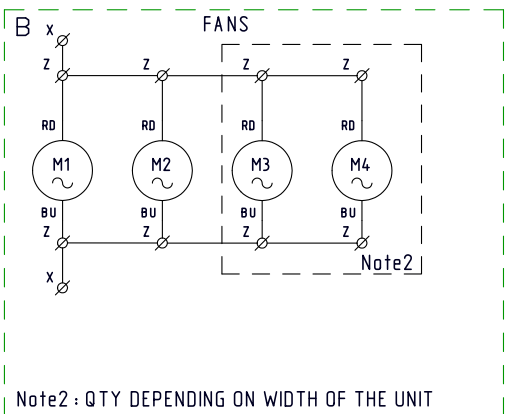

Note2: QTY DEPENDING ON WIDTH OF THE UNIT

MDD 36 208V MDD 48 208V 3~ 230V 3~ 208V	MDD 60-5 230V MDD 90 230V MDD 120 230V 3N~ 400V	MDD 24 208V MDD 60-4 230V 1N~ 230V 1~ 208V

06	27.06.2022	batch elec update
05	05.05.2022	update
REVISION	REV. DATE	REMARK
Tol. principle	Gen. tolerance	Surface treatment
		Geom. tolerance
MATERIAL		
MATERIAL ART. NUMBER	DRAWN den Rooijen Admin	APPROVED
UNIT mm	STATUS In Progress	DATE 28.04.2021
SCALE 1:1	PROJECT 939	DRAWING NUMBER 9390810
REMARKS DESCRIPTION		ART. NUMBER
Circuit diagram MDD MT 4-5		9390810
	REV. F	SIZE A3



Fri-Jado B.V.  
Blauwhekken 2  
4751 XD Oud Gastel  
The Netherlands  
Tel: +31 (0) 76 50 85 400

Fri-Jado Inc.  
1401 Davey Road, Suite 100  
Woodridge IL 60517  
USA  
Tel: +1-630-633-7950

<https://www.frijado.com>