

# USER MANUAL – USA Version

## Modular Convenience Counter – Hot



**WARNING**

Read the instructions before using the machine.

**KEEP THIS USER MANUAL FOR FUTURE USE**

© 2023 Fri-Jado B.V., Oud Gastel, The Netherlands.

We advise you to contact your supplier for the guarantee period and conditions. Further we refer to our General Terms and Conditions for Sales and Delivery that are available upon request.

The manufacturer does not accept any liability for damage or injury caused by failing to adhere to these regulations or by not observing the usual caution or care in actions, operation, maintenance or repair activities, even if not explicitly described in this manual.

As a result of constant commitment to improvement, it may happen that your unit deviates in detail from what is described in this manual. For this reason, the given instructions are only a guideline for the installation, use, maintenance and repair of the unit referred to in this manual.

This manual has been composed with the utmost care. The manufacturer shall, however, not be held responsible for any mistakes in this manual nor for any consequences thereof.

The user is allowed to copy this manual for own use. Further all rights are reserved and nothing in this manual may be reproduced and/or made public in any way.

**Modifications:**

In case of unauthorized modifications in or on the unit, every liability on the part of the manufacturer becomes null and void.

# CONTENTS

<b>1.</b>	<b>INTRODUCTION .....</b>	<b>5</b>
1.1	General.....	5
1.2	Identification of the unit.....	5
1.3	Pictograms and symbols.....	5
1.4	Safety instructions .....	6
1.4.1	General.....	6
1.4.2	Moving (when applicable).....	7
1.4.3	Outdoor use restrictions.....	7
1.5	Hygiene .....	7
1.6	Service and technical support.....	7
1.7	Storage.....	8
1.8	Disposal.....	8
<b>2.</b>	<b>DESCRIPTION OF THE UNIT .....</b>	<b>9</b>
2.1	Technical description .....	9
2.2	Intended use.....	9
2.3	Accessories .....	9
<b>3.</b>	<b>INSTALLATION AND FIRST USE .....</b>	<b>10</b>
3.1	Unpacking the unit.....	10
3.1.1	Unpacking the front doors (optional).....	11
3.2	Installation and positioning.....	11
3.2.1	Level the unit.....	12
3.2.2	Mounting the plinths.....	12
3.2.3	Mounting front doors (optional).....	13
3.2.4	Applying price rail .....	14
3.3	Drop-in units .....	14
3.4	Repositioning the glass shelves.....	15
3.4.1	FS & SS-Humidified models .....	15
3.4.2	Self-Serve models .....	16
3.5	Plateau Options .....	16
3.6	Humidification Full-Serve and Self-Serve-Humidified models.....	17
3.6.1	Water connection automatic .....	17
3.6.2	Manually fill.....	18
3.7	First use.....	19
<b>4.</b>	<b>OPERATION AND USE .....</b>	<b>20</b>
<b>5.</b>	<b>CLEANING AND MAINTENANCE .....</b>	<b>22</b>
5.1	Maintenance schedule.....	22
5.2	Daily Cleaning.....	22
5.3	Weekly Cleaning.....	22
5.4	Cleaning Glass Panes .....	23
5.5	Cleaning air guides, fans and water tray humidified (optional) models .....	29

---

<b>6.</b>	<b>MALFUNCTIONS AND SERVICE .....</b>	<b>32</b>
6.1	Replace the mains cord .....	32
<b>7.</b>	<b>TECHNICAL SPECIFICATIONS .....</b>	<b>33</b>

## 1. INTRODUCTION

### 1.1 General

This manual is intended for the user of the Hot MCC (Modular Convenience Counter). The features and controls are being described, along with directions for the safest and most efficient use, in order to guarantee a long life of the unit.

All pictograms, symbols and drawings in this manual apply to all available Hot MCC (US) models.

### 1.2 Identification of the unit

The identification plate can be found on the outside of the machine, and contains the following data:

- Name of the supplier or the manufacturer
- Model
- Serial number
- Year of construction
- Voltage
- Frequency
- Power consumption

### 1.3 Pictograms and symbols

In this manual, the following pictograms and symbols are used:



**WARNING**

Possible physical injury or serious damage to the unit, if the instructions are not carefully followed.



**WARNING**

Hazardous electrical voltage.



**WARNING**

Danger of getting injured by hot surfaces.



**SAFETY**

Wear safety gloves for installation and dismantling.



Suggestions and recommendations to simplify indicated actions.



Recycling symbol.

## 1.4 Safety instructions



### WARNING

The outside and shelves of the unit can be very hot.



### WARNING

The maximum load on top of the unit may never exceed 22 lbs.



### WARNING

See installation instructions for grounding requirements.



### WARNING

Always use the brakes on both front wheels:

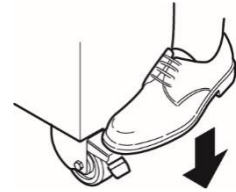

### 1.4.1 General

The user of the unit will be fully responsible for abiding the locally prevailing safety- rules and regulations.

The unit may be operated by qualified and authorized persons only. Anyone working on or with this unit must be familiar with the contents of this manual and carefully follow all guidelines and instructions. Never change the order of the steps to be performed. The management must instruct the personnel on the basis of this manual and follow all instructions and regulations.

The pictograms, labels, instructions and warning signs attached to the unit, are part of the safety measures. They may never be covered or removed, and have to be clearly visible during the entire lifetime of the unit.

Immediately repair or replace damaged or illegible pictograms, warnings and instructions.

- To avoid short-circuiting, never clean the unit using a water hose. For cleaning instructions, see section 5.
- The shelves, glass and back of the hot unit can get hot.
- The unit must be cleaned regularly to ensure proper functioning.
- Do not store explosive substances such as aerosol cans with flammable propellant in this appliance.
- This appliance can be used by children aged from 8 years and above and persons with reduced physical, sensory or mental capabilities or lack of experience and knowledge if they have been given supervision or instruction concerning use of the appliance in a safe way and understand the hazards involved.
- Children shall not play with the appliance.
- Cleaning and user maintenance shall not be performed by children without supervision.

### 1.4.2 Moving (when applicable)

When moving the unit:

- Before moving the unit, first switch off the mains voltage by pulling the plug from the wall socket.
- Remove pans containing a liquid product from the unit.
- Always keep the unit in upright position.
- Make sure that the wheels can move freely, so they never touch the power lead.

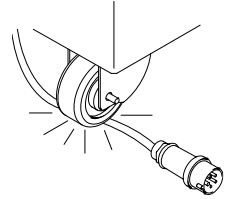

### 1.4.3 Outdoor use restrictions



#### **WARNING**

To avoid short-circuiting, the units may not be used outdoors or in a rainy or very moist environment.

## 1.5 Hygiene



#### **WARNING**

Immediately remove products in damaged packaging from the equipment and destroy the products. Clean all components that have come in contact with products from damaged packaging.

The quality of a fresh product always depends on hygiene. It is essential that products are packaged immediately after preparation. Prevent fresh raw vegetables or already prepared, cooled products from coming into contact with raw meat products to avoid transmitting salmonella. First thoroughly clean hands and/or tools that have touched raw meat.

For hot products, the core temperature of the products at packaging should at least be 185°F.

Be aware that high humidity levels may encourage the growth of biological organisms in the environment.

Refer to the cleaning instructions of section 5.

## 1.6 Service and technical support

The electrical schematics of your unit is included. In case of malfunctions you can contact your dealer/service agent. Make sure you have the following data available:

- Model.
- Serial number.

This data can be found on the identification plate.

**1.7 Storage**

If the unit will not be used temporarily, and will be stored, follow these instructions:

- Clean the unit thoroughly.
- Wrap the unit from getting dusty.
- Store the unit in a dry, non-condensing environment.
- FS and SS-Humidified models: empty water tray.

**1.8 Disposal**

Dispose of the machine, any components or lubricants removed from it safely in accordance with all local and national safety and environment requirements.

## 2. DESCRIPTION OF THE UNIT

### 2.1 Technical description

The panels are made of galvanized steel plating, stainless steel or aluminum. Some of the visible internal and external parts have been provided with a powder coating. The glass used is tempered or layered. The unit can be moved by means of a pallet truck. The controls for operating the appliance have been mounted on the operator side of the unit. The product contact parts are made of stainless steel AISI 304 or AISI 430 and tempered glass.

Heating in open front hot self-serve units is achieved by means of heated shelves in combination with an hot-air curtain per shelf. The air curtain isolates the hot air inside the unit from the ambient air.

Hot full serve units have a single heat source in the base of the cabinet and use fans to distribute the heat throughout the cabinet. The open front hot self-serve units are available in a 2 and 3 level execution and the full serve and humidified self-serve units are also available in a 4 level execution. An electronic thermostat controls the temperature. The electronic thermostat has been set at the correct value at the factory. This value can be changed for self-serve models between 104°F and 158°F and for full serve and self-serve humidified models between 104°F and 203°F.

One LED-module per level provides for lighting of the products. The LED-lighting and the heating are switched on and off separately.

Full serve and humidified self-serve units can be fitted with an optional humidification system in the form of a passive water tray. For the Self-serve models there are two user variants; a solid back version and a pass through version which allows the user to (re)fill products via the back side.

### 2.2 Intended use

Self-serve models (SS models) have been designed solely to keep packaged products warm and to display them. Full serve and self-serve humidified models can be used for unpacked foodstuff as well. Any other use will not be regarded as intended use.

The manufacturer accepts no liability whatsoever for loss or injury caused by failing to strictly adhere to the safety guidelines and instructions in this manual or due to carelessness during installation, use, maintenance and repair of the unit referred to in this manual and any of its accessories.

Use the unit in perfect technical condition only.

### 2.3 Accessories

Your unit contains the following standard accessories:

- User manual.
- Plinth set.
- Front doors (when applicable).

For optional accessories see [www.frijado.com](http://www.frijado.com).

### 3. INSTALLATION AND FIRST USE



All packing materials used for this unit are suited for recycling.

Before and during unpacking, check the state of the unit. In case of damage, store the packing material, and contact the transporter within fifteen working days after receiving the goods.

#### 3.1 Unpacking the unit

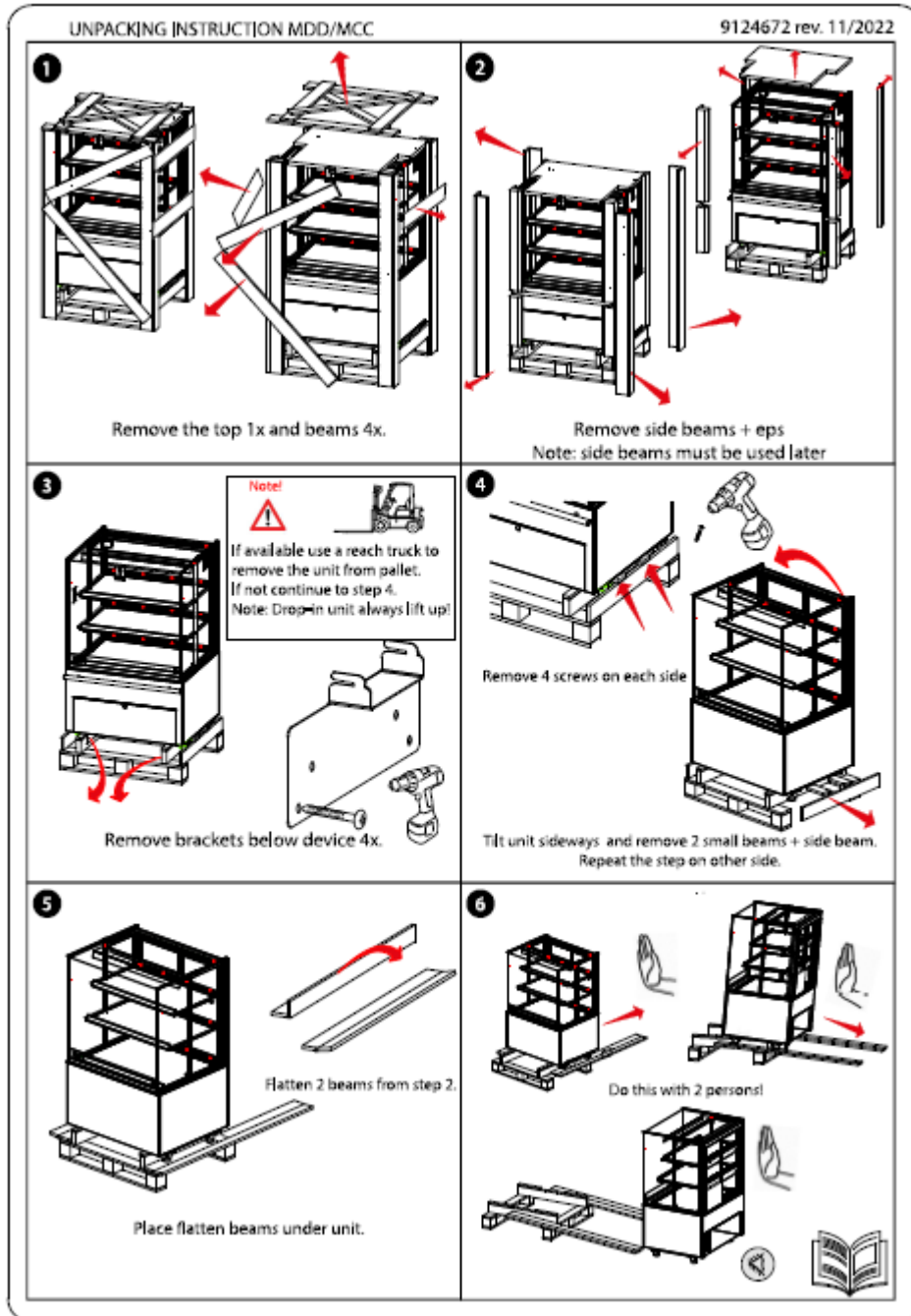

1. Unpack the unit as initiated on the unpacking instruction on the packaging.
2. Remove all remaining packing materials from the unit.
3. Remove the protective foil from the metal parts.
4. Take off the standard accessories.

### 3.1.1 Unpacking the front doors (optional)

The front door(s) (1-3) and fixings are placed in a crate during transport.

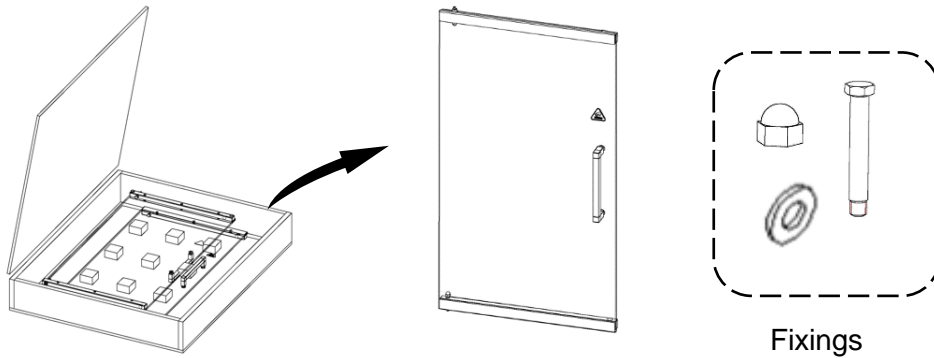

### 3.2 Installation and positioning



#### **WARNING**

Electric shock hazard. Grounding instructions: only connect the appliance to an alternating current provided by a grounded wall socket, with a mains voltage in accordance with the information indicated on the data plate of the appliance.

It is the consumer's responsibility to make sure the electrical installation conforms with current national and local codes and wiring regulations.

Do not use a multi plug or extension cord. Such can result in fire, electrical shock, or other personal injury.

Failure to follow these instructions can result in death or serious injury.



#### **WARNING**

Position the unit on a flat and horizontal surface. A temporally inclined plane of maximum 5° is allowed.

- Place the unit level on a sufficiently sturdy floor. Keep the weight of the unit in mind. Use a levelling instrument to level the unit by adjusting the unit's legs.
- Be sure that the personnel have sufficient room to work with the unit.
- Keep a distance of at least 6 inch between the back wall and the unit.
- While positioning, keep the unit out of children's reach.
- Do not position a unit near a doorway, a ventilation device or a refrigerator in order to avoid any negative effects on the unit's operation by a cold airflow. The unit is designed for a maximum draft of 0.65 ft./sec.
- Do not place into direct sunlight.
- Be sure that the minimum ambient temperature is 68°F.
- The unit has a mains plug, and must be connected to a wall socket with the proper mains voltage. The wall socket must be mounted by a certified electrician.
- Keep the plinth free from any obstacles to ensure ventilation.
- FS and SS Humidified models: Strongly advice to connect unit to a fixed drainage. Ensure drainage connected correctly.
- FS and SS Humidified models: Minimum water pressure of 150 kPa. Maximum water pressure of 600 kPa. Recommended water pressure of 150 – 200 kPa.

**3.2.1 Level the unit**

Place the unit on a sturdy, flat surface and level the unit by adjusting the unit's legs (max. +1/2 inch).

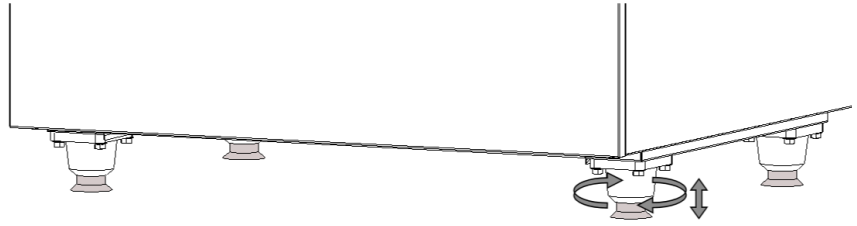

**3.2.2 Mounting the plinths**

Place the rear plinth by attaching it to both rear adjustable legs using its two clamps.

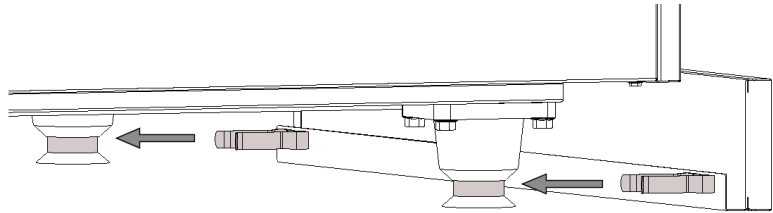

Insert the pegs of both side plinths into the slots of the rear plinth.

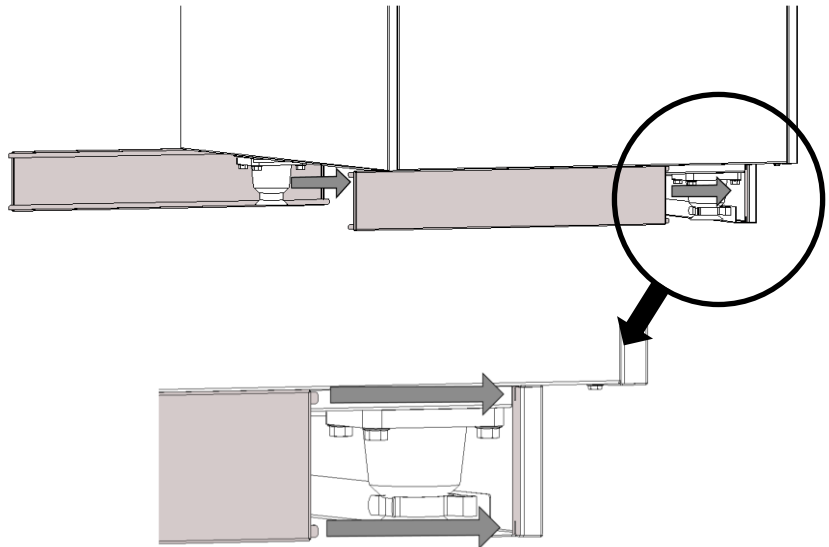

Secure the side plinths by inserting the pegs into the slots of the front plinth, while clamping the front plinth to the front adjustable legs.

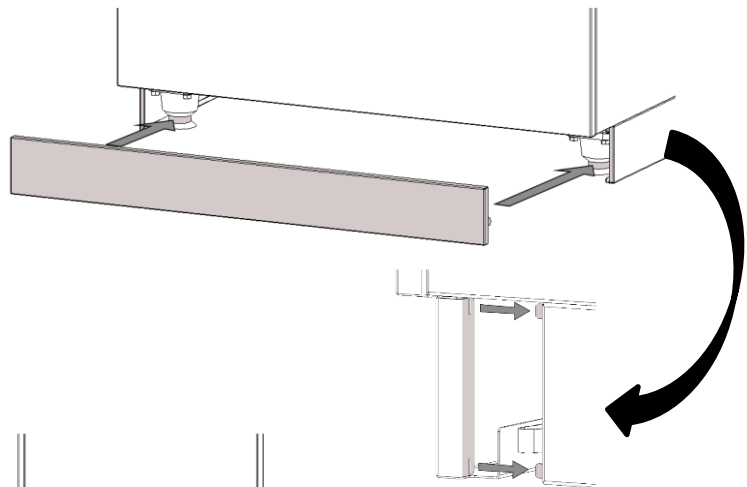

Result

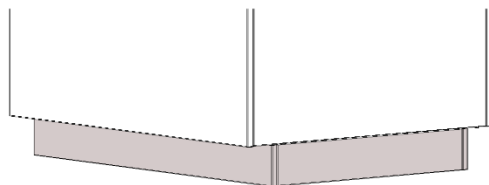

### 3.2.3 Mounting front doors (optional)

Position the doors with the handles to the outside and with the warning sticker above the handle.

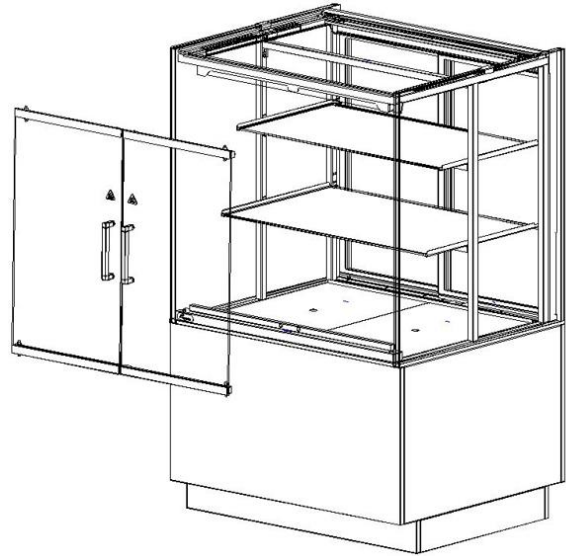

Position the door over the bottom profile and place a plastic spacer between the bottom profile and the collar bearing. Insert the retaining bolt from the top and tighten.

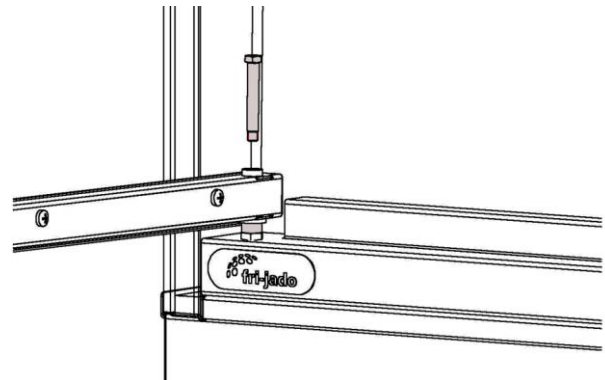

Place a protective cap over the bolt head.

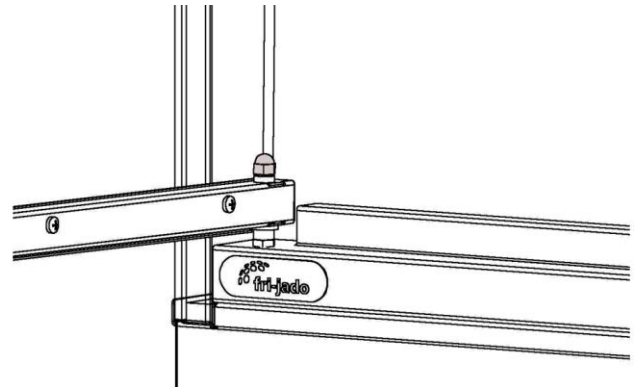

Repeat the same process on the upper part of the door.

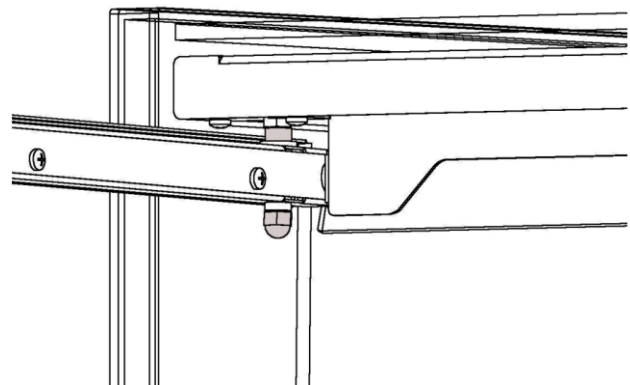

Result

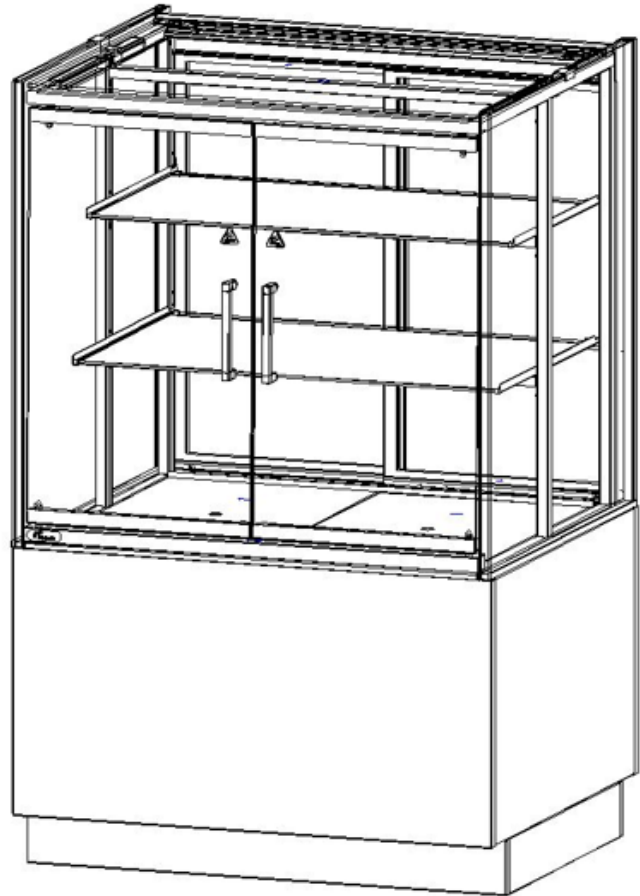

### 3.2.4 Applying price rail

Optional price rails for self-serve models can be mounted using the front screws underneath each of the SS shelves. Price rails for full serve models can be mounted on the air inlet grill and on the glass shelves. Refer to installation manual.

### 3.3 Drop-in units

For installation of the Drop-in units refer to instruction 9124589.

### 3.4 Repositioning the glass shelves

#### 3.4.1 FS & SS-Humidified models

The glass shelves can be positioned at three horizontal levels (I), or one of the three angled positions (II and III) by changing the positions of the LED-armature with respect to the rear.



In order to change to any of these positions, follow the steps in the example below to change from a horizontal to an angled position. Reverse the steps to change to a horizontal position from an angled position.

1. Carefully lift the glass shelf out of its side supports.

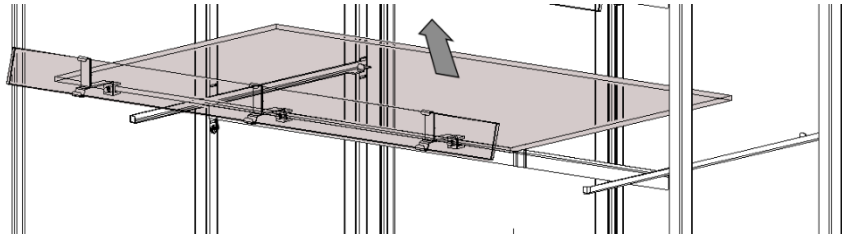

2. Remove the side supports from the rear columns by rotating them out.

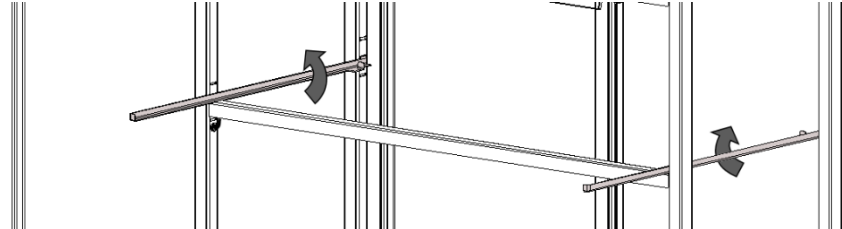

3. Lift the LED-armature from its supports, but be careful to not strain, clamp or otherwise damage the cable.

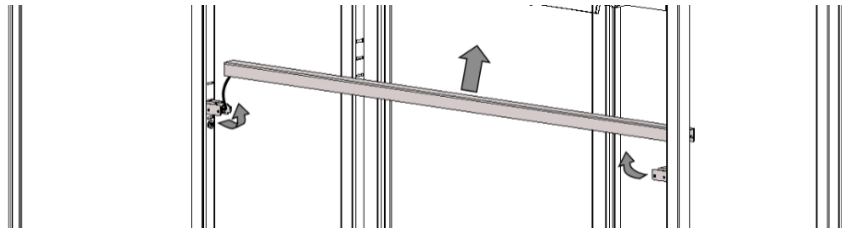

4. Reposition the LED-armature supports by taking them out of the central column and inserting them back in at the desired level.

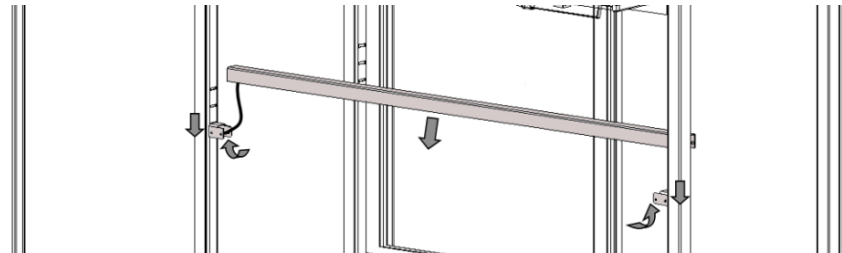

5. Position the side supports at the desired height by inserting them into the rear column. Let the front end rest on the LED-armature.

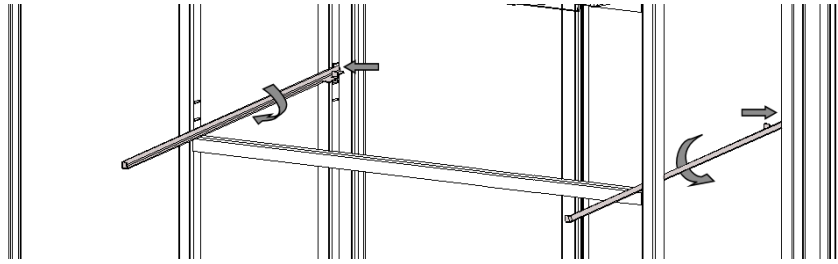

Please note that the rear level is supposed to be located at an equal or higher level than the LED-armature.

6. Place the glass shelf back onto its supports.

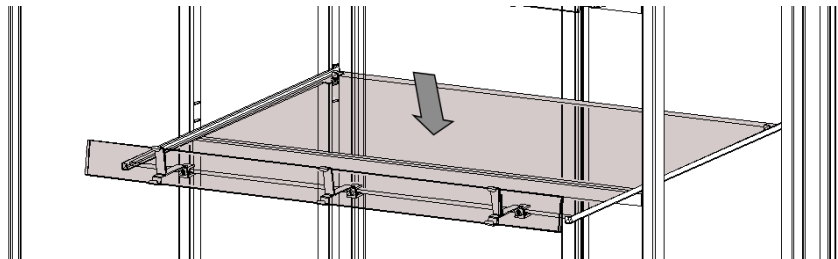

### 3.4.2 Self-Serve models

The glass shelves can be positioned at two angled positions (0° and 3°). Refer to installation manual.

### 3.5 Plateau Options

On FS and SS-Humidified models the bottom presentation deck can be set at a variety of horizontal levels (I, II, III) and angles (IV, V, VI) as seen in the sideview cross-section for different display experiences.

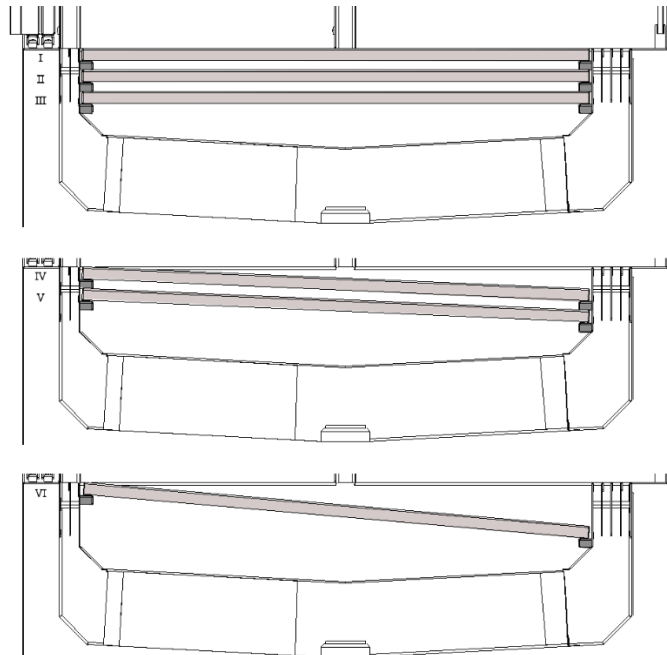

To change to a different position:

- Remove the plateaus from the unit.
- Reposition the supports at the front and the back to the desired positions.
- Place the plateaus back in the unit.

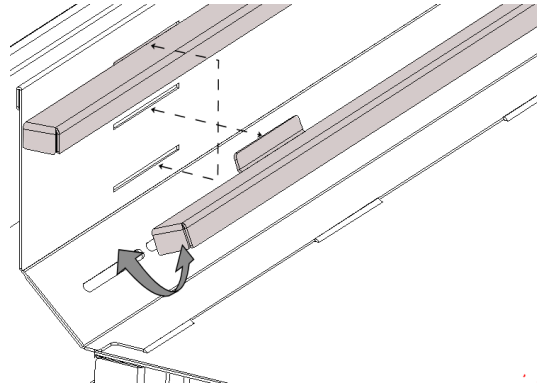

### 3.6 Humidification Full-Serve and Self-Serve-Humidified models

#### 3.6.1 Water connection automatic

When connect to the water supply the FS and SS-Humidified will fill the water tray automatic when the water level is too low.

How to connect the water supply:

- Remove the front panel screws.  
(When delivered with under frame.)
- Remove the front panel.

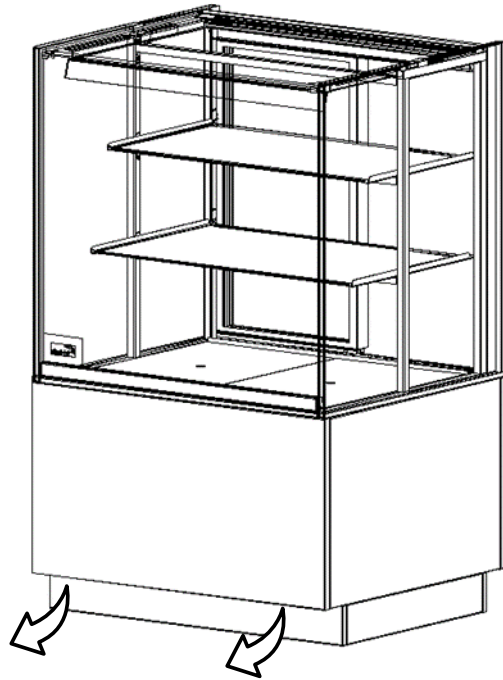

- Connect the water supply hose to the 12 mm inlet pipe of the water tray (3/4" connection also possible).
- Remount the front panel and secure it with the screws.

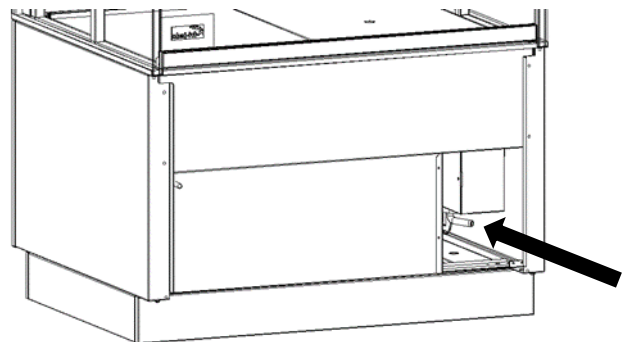

**Limescale filter:**

To reduce the amount of limescale, place a scale filter in the water supply.

### 3.6.2 Manually fill

- When the water level in the reservoir drops below the minimum level, an alarm light will light up underneath the Humidifier button.

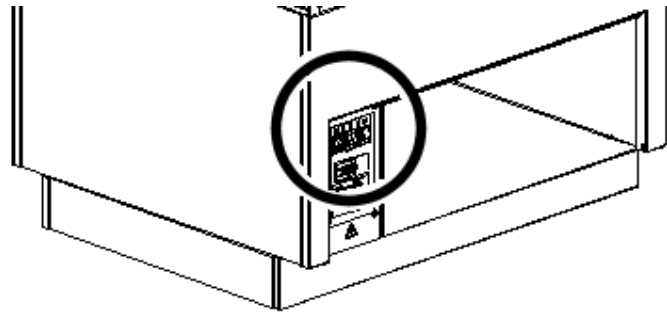

- Fill the water tray. Look for the required volume of water in the table below.



**Warning**  
Do not overfill the water tray!

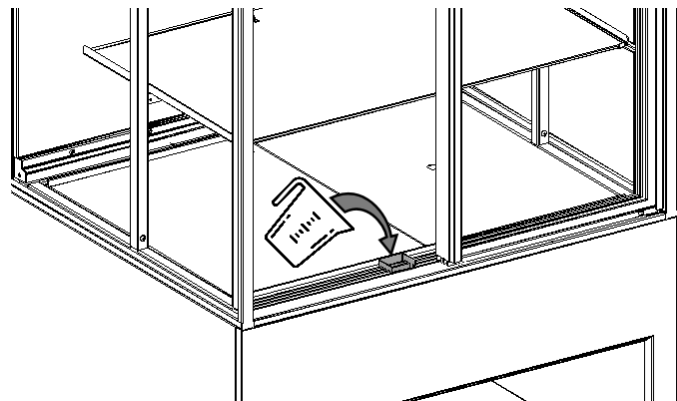

Unit	GN tray size	Max. reservoir water level	Reservoir water level when alarm activates	Max. water volume to add (only when alarm is on!)
MCC-60 H	GN 1/2 (1.6 in)	0.66 gallon	0.19 gallon	0.46 gallon
MCC-90 H	GN 1/1 (1.6 in)	1.32 gallon	0.39 gallon	0.92 gallon
MCC-120 H	GN 1/1 (1.6 in)	1.32 gallon	0.39 gallon	0.92 gallon

Indication water consumption (depending on usage) approx. 0.12 gallon/hr.

- Once the water reservoir has been filled. Switch the alarm button of the humidifier 5 second off and switch it back on.

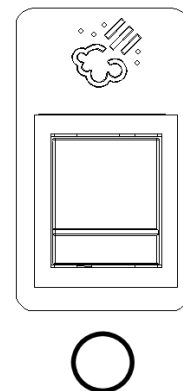

### 3.7 First use

Before starting to use the unit, clean the inside thoroughly with mild detergent and water. After cleaning it wipe it with a cloth moistened with clean water to remove residual detergent, then dry the entire unit.



**Warning regarding to automated humidifier:**

When filling the water tray for the first time, water may come out of the pipe at high speed. This is the result of air that was trapped in the pipe or water hose.

## 4. OPERATION AND USE



The display and/or set value is not the product/unit temperature.



The unit is set at 149°F intake air temperature for the self-service model and 203°F for full serve and self-serve humidified models. If required this temperature can be adjusted to some degree.

At a ambient temperature of 68°F and an initial core temperature of 185°F these factory settings of the unit's temperature ensure a constant core temperature of at least 149°F for 4 hours.

### Control Panel

On/Off Switches.

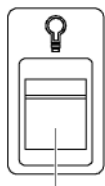

Lighting



Heating

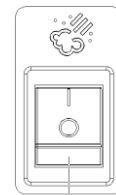

Humidifier  
(Option)

### Temperature controller

- ⏻ Power on/off button\*
- ⬆ UP-button
- ⬇ DOWN-button
- SET ↩ SET-button



Picture for reference only.

\* Switch on/off: hold for several sec.

### Switching-on the unit

- Switch the heating on.
- Preheat the unit for approx. 30 minutes.
- Switch on the lighting.
- Humidification (FS and SS-humidified models only): apply water supply / manual fill (see section 3.6).

### Loading the unit

- Only place products that have a core temperature of at least 185°F.
- Only package the hot products in bags or containers that are suitable for this purpose.
- To ensure a good contact with the heated trays, only place a single layer of products.
- The maximum loading height is 2 inch below the bottom of the shelf/air guide above.
- The maximum carrying-capacity per shelf is 20.2 lbs/ft, by equal load.

### Checking the temperature in the unit

- During operation the display of the thermostat shows the temperature at the probe in the unit. The indication ON will light when the elements are active.

### Checking the SET temperature

1. Scroll through the folders with **^** and **v** button until you find the folder **Pb1**, **Pb2** or **Pb3**.
2. Press **SET** to view the value measured by the corresponding probe.

### Adjusting the SET temperature

1. During operation the display of the thermostat shows the temperature in the unit.
2. Push twice on the **SET**-button. The set temperature will appear on the display.
3. Push the **^** and **v** button within 15 sec.
4. Adjust the set temperature by means of the **^** and the **v** button.
5. Push once on the **SET**-button to store the new set temperature.

### Checking the product temperature

- Once every hour, the product temperature should be checked using a digital thermometer. Write down the measured values in a log.
- Always use a disinfected thermometer sensor.

### Switching off

- Remove all products from the unit. In order to avoid temperature drop of the products, store them in another warm holding unit.
- Switch the heating off.
- Switch the lighting off.
- FS and SS humidified models only: close water supply when applicable.

## 5. CLEANING AND MAINTENANCE



### WARNING

Never use a water hose for cleaning. Water can seep into the unit through the ventilation holes of the unit.

Appliances must be disconnected from their power supply during cleaning or maintenance and when replacing parts.



Because of hygiene aspects and optimum condition of the unit it is of utmost importance to keep a daily cleaning pattern from first use onwards.

### 5.1 Maintenance schedule

Item	Action	Frequency
Inside	<ul style="list-style-type: none"> <li>• Clean, see section 5.2.</li> </ul>	Daily
Outside	<ul style="list-style-type: none"> <li>• Clean, see section 5.3.</li> <li>• Use Stainless Steel cleaning spray to remove stains, and restoring the gloss.</li> </ul>	Weekly
Glass panes	<ul style="list-style-type: none"> <li>• Clean, see section 5.4.</li> </ul>	Weekly
Bottom air guides	<ul style="list-style-type: none"> <li>• Clean, see section 5.5.</li> </ul>	Weekly
Humidifier	<ul style="list-style-type: none"> <li>• Remove any calcium build-up in the water tray and on the pins of the water level sensor. Possible detergent: hot water and vinegar. See section 5.5.</li> </ul>	Weekly

### 5.2 Daily Cleaning

- Clean the inside of the unit with hot water and a suitable cleaner.
- After cleaning wipe the inside with a clean wet cloth. Be sure that the detergent is removed properly.

### 5.3 Weekly Cleaning



### WARNING

The control panel may only be cleaned using a damp cloth.

- Clean the outside of the unit with a small amount of hot water and a mild cleanser and using a soft brush or sponge. After cleaning it dry the outside with a cloth.
- Treat all cleaned surfaces with a suitable antibacterial agent.
- Rub dry with a soft cloth or a paper towel.

## 5.4 Cleaning Glass Panes

### Cleaning the top glass pane

- For all MCC variants, lift and hold the top glass while cleaning the top glass pane.

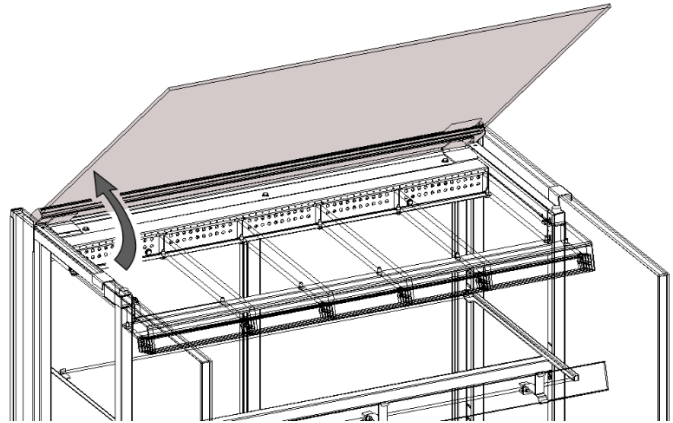

### Cleaning the top air guides



#### WARNING

Do not use detergents and other cleaning products that may damage polycarbonate. Using inappropriate products to clean may tarnish, scratch or even crack any polycarbonate surfaces.

The transparent air guide pane can be removed for cleaning.

- Lift and hold up the top glass pane throughout the process.
- The air guide pane is laid up freely and somewhat flexible and can as such easily be removed from its support on the rear by applying a light amount of torsion.
- After cleaning, place the air guide pane back by applying some light torsion.
- Close the top glass pane.

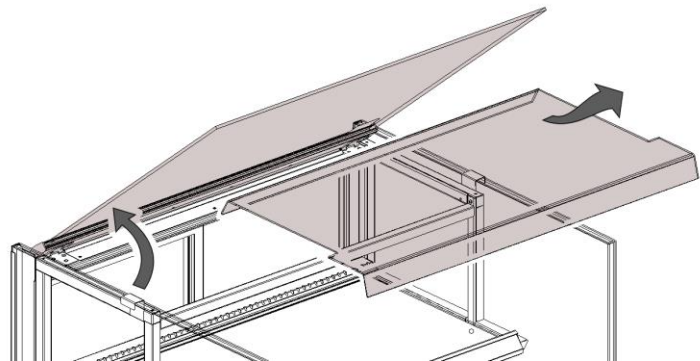

### Cleaning the side double-glass pane

- Slide the double glass pane towards the front along the top (A) and bottom (B) guiding rails. The side pane can be removed from the unit once it has slid in its entirety past the top guide.

**CAUTION:** Once past the top guide, the glass pane might fall if not properly held. Hence do not leave it standing upright without being supported by both guide rails or holding it.

- It is recommended to only move the pane to such an extent that the pane areas next to the support columns can be cleaned.
- To clean the guiding rails, the pane can be removed in its entirety.
- If the pane was removed and needs to be placed back in, before sliding the pane back into the rails, ensure the transparent sides of the pane are facing forwards and up. Then slide it all the way back till the front of the pane is in line with the front plating.

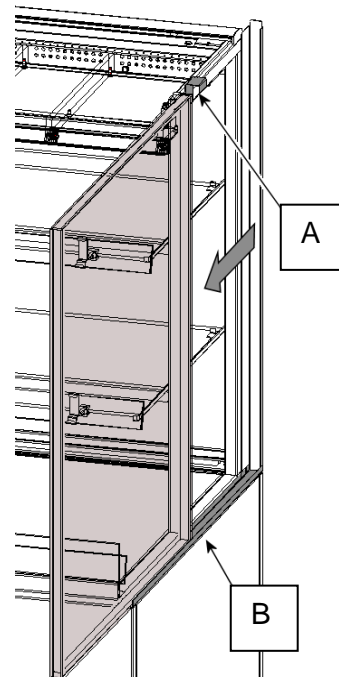
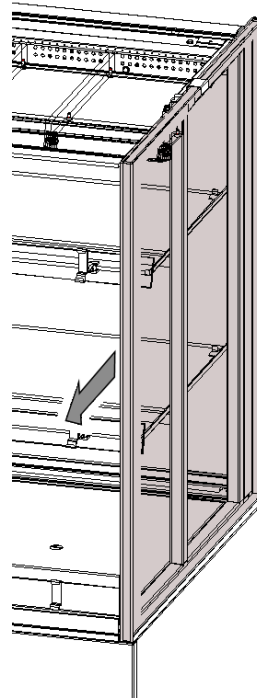

Cleaning front window

- Lift and hold the top glass, the front glass will automatically remain in position

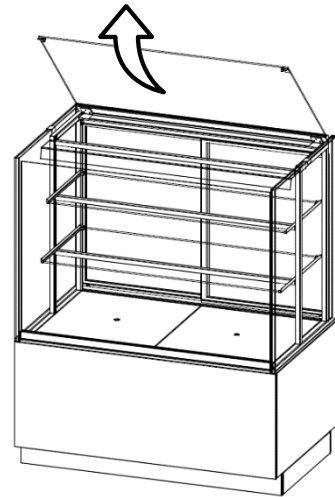

- Gently tilt the front glass forward (do not drop) whilst holding the top glass.

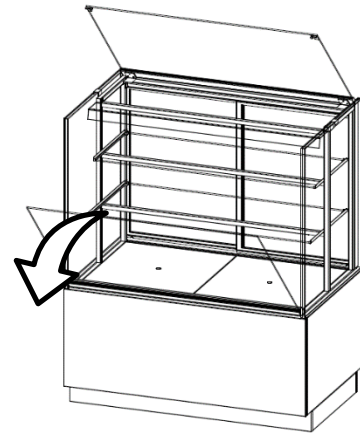

- Lower the top glass back in place.
- Clean the front glass.

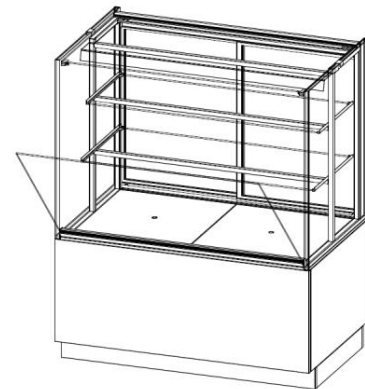

- **Closing:**  
Lift and hold the top glass whilst closing the front glass. A positive snap will make sure it stays into the upright position

- Gently lower the top glass back in place. Ensure the tabs on the edge of the top glass fit over the edge of the front glass

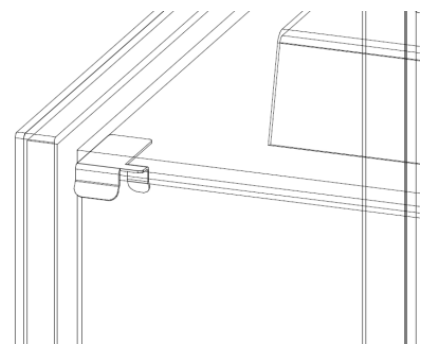

**Cleaning sliding doors and rear of shelves**



Always keep the sliding doors closed as much as possible, or the unit cannot maintain its climate. Cleaning the sliding doors is therefore recommended during off-hours. Follow the following steps to access the inner sides of the sliding doors and the rear of the shelves for cleaning.

- Slide the right (outermost) door open until its slot aligns with the guiding pin.

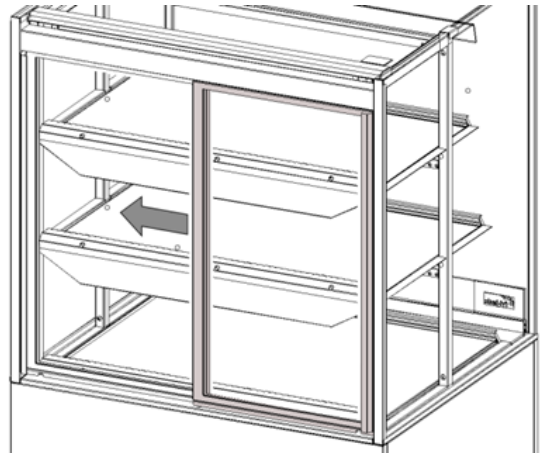

- Turn the outermost door outwards along the guiding pin.
- Clean the outermost door.

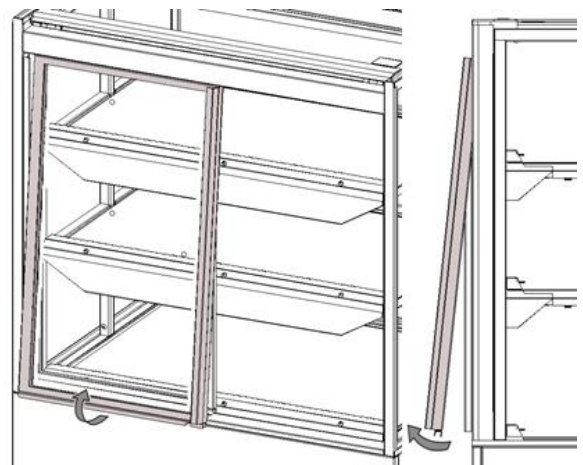
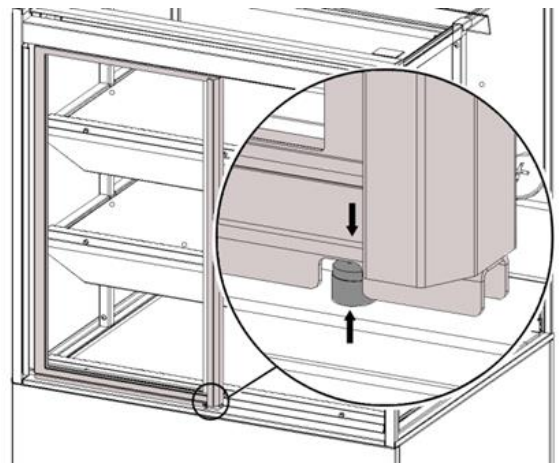

- To clean the left (innermost) door, slide both doors to the right until the innermost door's slot aligns with the guiding pin.

**NOTE:** The outermost door should still be in its rotated position.

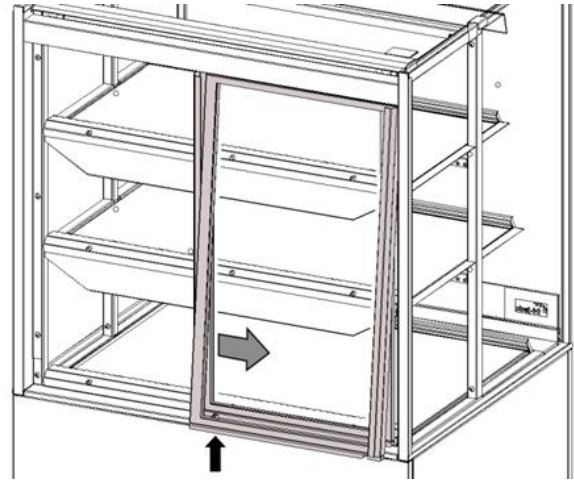

- Turn the innermost door outwards as well to clean it.

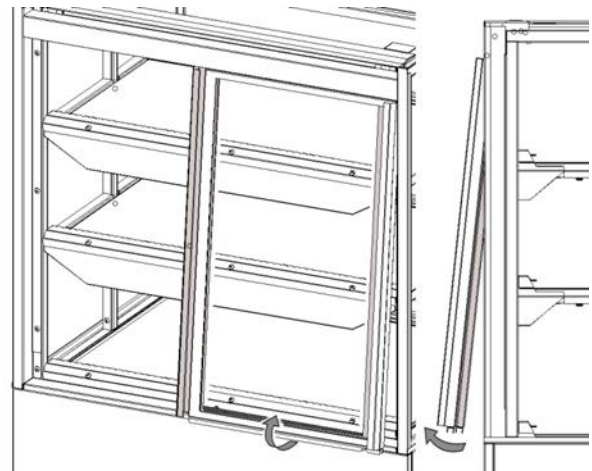

- Follow the above steps in reverse order to return both doors to their original positions.
- Close both doors.

**Cleaning front door(s) (optional)**

- Clean the outside of the front doors.

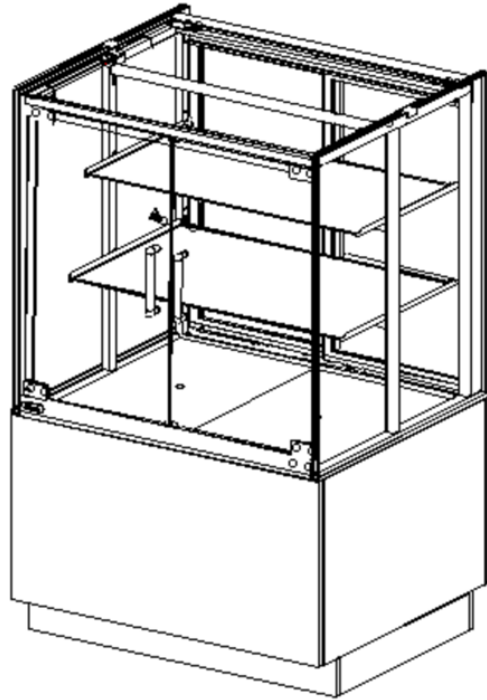

- Open the front doors and clean the inside of the doors in the same way as the outside.

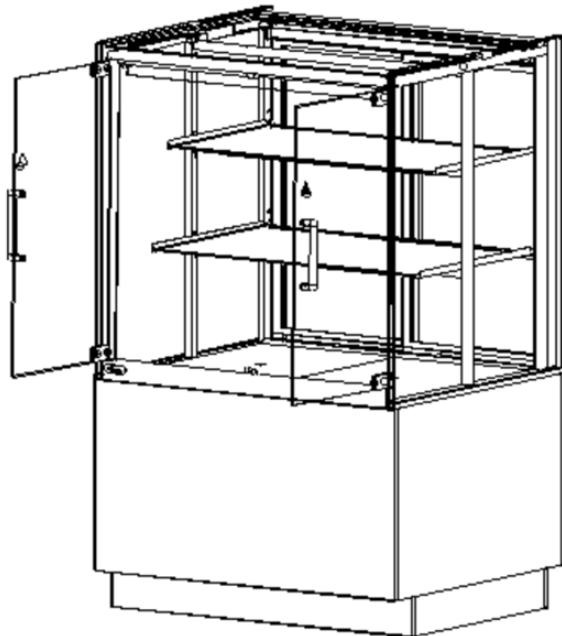

5.5 Cleaning air guides, fans and water tray humidified (optional) models



**WARNING**

Switch off the unit first and let it cool down.  
Be aware of rotating parts.

- Remove first the plating of the lower presentation deck.

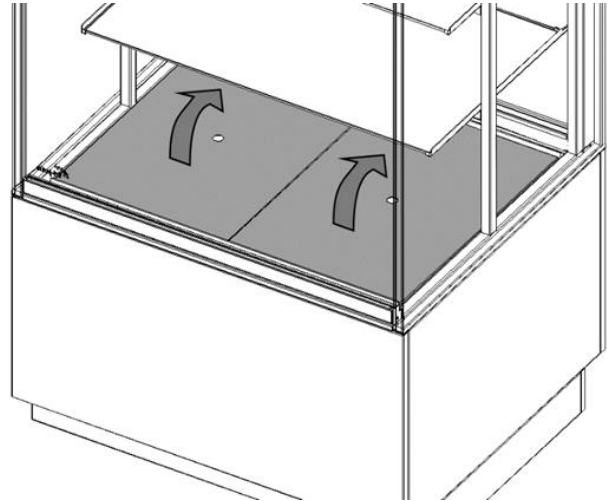

- Remove the plating above the water tray.

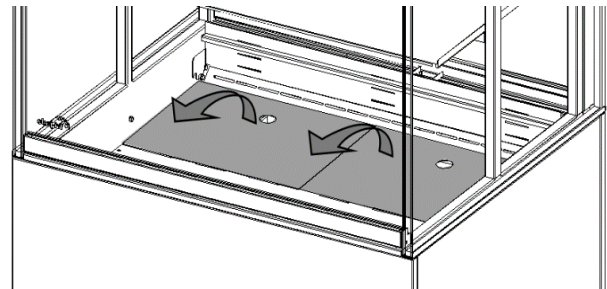

- To clean the inlet (A) and outlet (B) air guides.

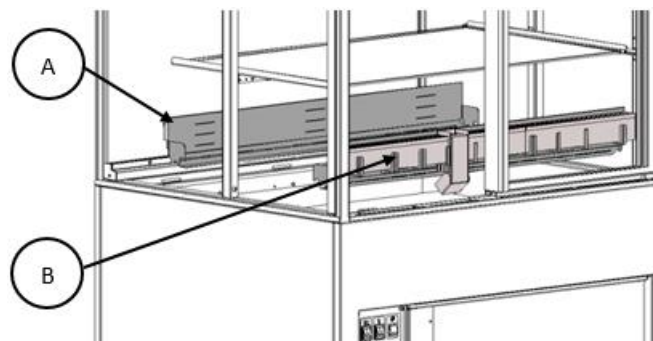

- Remove the inlet air guides at the frontside and clean them.

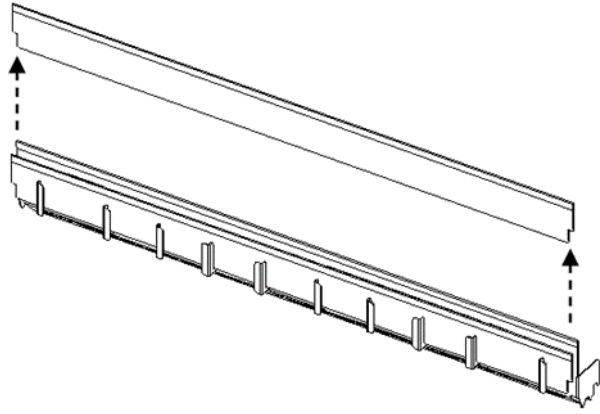

- Remove the outlet air guides at the backside and clean them.

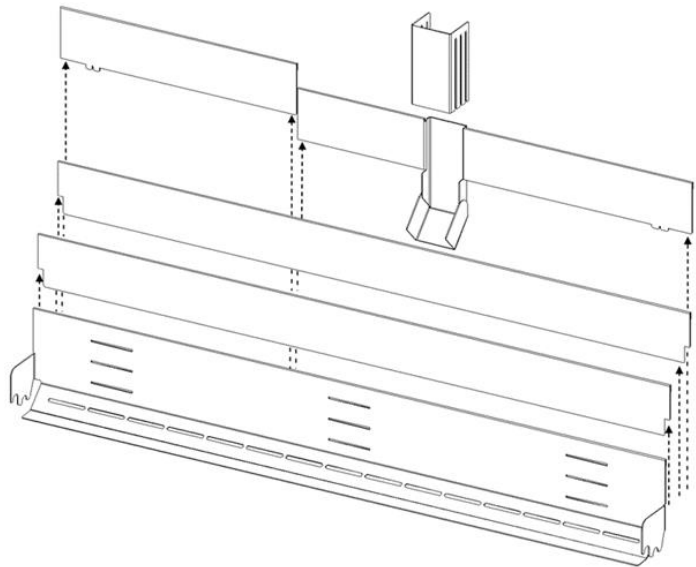

- To clean the water tray: lift up the water level sensor pins and remove the water tray as shown.

**NOTE:** The water level sensor pins need to be positioned back in the water tray after cleaning.

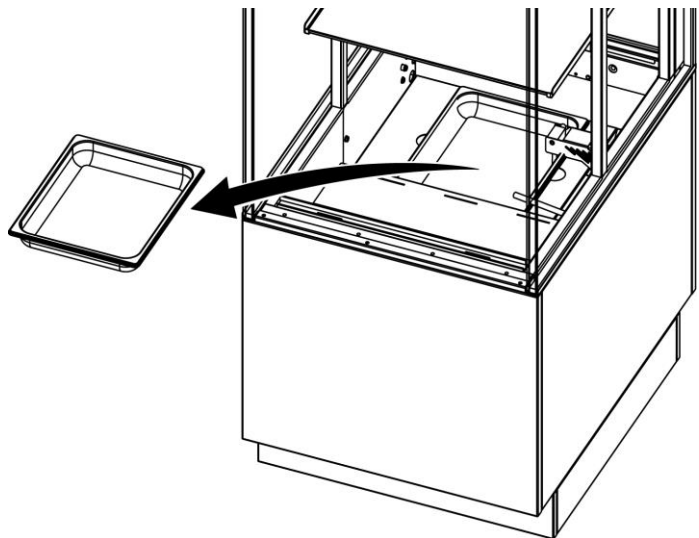

## Only FS models

- Clean the fans (when needed) with a brush. Fans are positioned below the inlet air guides.

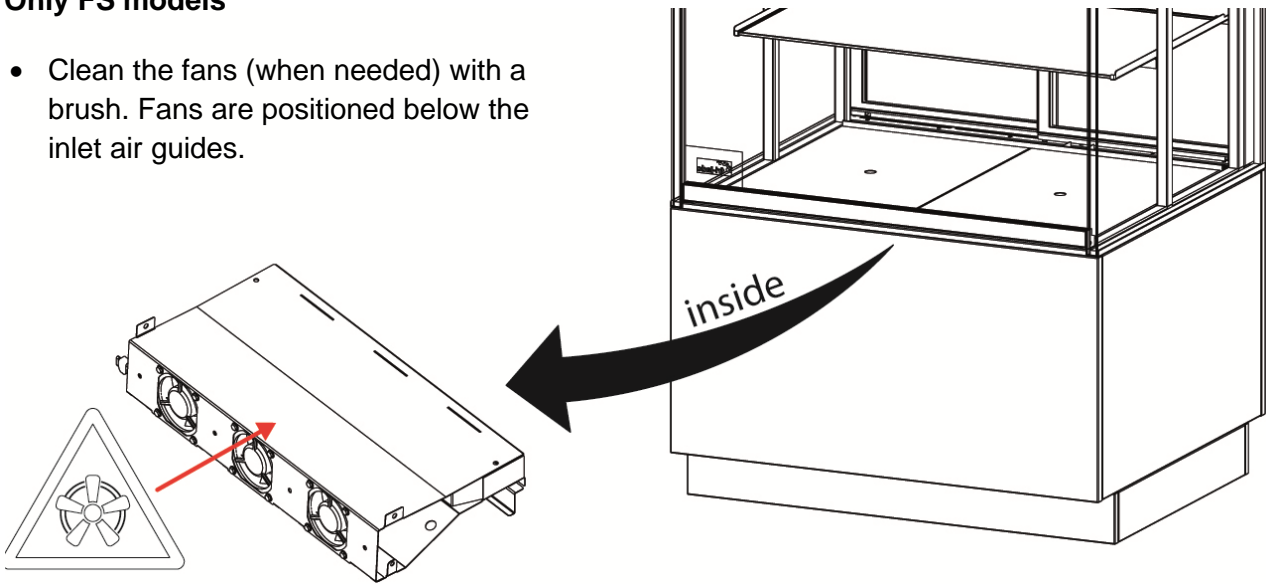

- Follow the above steps in reversed order to reassemble the air guides and plates.

## 6. MALFUNCTIONS AND SERVICE

Before you consult your dealer or the service agency when there is a fault, you can check the following points yourself:

- Is the power supply OK? Check the fuses and the earth leakage switch in the meter cupboard.
- Are all the switches in the correct position?

Item	Malfunction	Possible action
Unit	Unit does not work	<ul style="list-style-type: none"> <li>• Check the power supply.</li> <li>• Are all switches in the correct position.</li> </ul>
Unit	Display shows error code	<ul style="list-style-type: none"> <li>• Contact your supplier or service agency.</li> </ul>
Lamp	Does not light up	<ul style="list-style-type: none"> <li>• Switch ON.</li> </ul>
Humidifier	Warning light humidifier	<ul style="list-style-type: none"> <li>• Check water level/supply.</li> <li>• Reset by pushing the switch for a few seconds.</li> </ul>
Mains cord	Damaged	<ul style="list-style-type: none"> <li>• Replace, see section 6.1.</li> </ul>
Window	Damaged	<ul style="list-style-type: none"> <li>• Replace, contact your supplier or service agency.</li> </ul>

### 6.1 Replace the mains cord



**WARNING**

Hazardous electrical voltage.

If the mains cord is damaged, it must be replaced by the manufacturer, his service agent or a similarly qualified person in order to avoid hazards.

## 7. TECHNICAL SPECIFICATIONS

**WARNING**

Consult the identification plate to get the proper specifications of the unit. The electrical data may vary from country to country.

### Self-service models

<b>Model</b>	<b>MCC</b>	<b>24-2-H SS</b>	<b>36-2-H SS</b>	<b>48-2-H SS</b>
Approved for		USA / CAN	USA / CAN	USA / CAN
Width		23 5/8 in	35 7/16 in	47 1/4 in
Depth		29 1/2 in	29 1/2 in	29 1/2 in
Height on stand		55 7/8 in	55 7/8 in	55 7/8 in
Height above worktop		20 1/2 in	20 1/2 in	20 1/2 in
Weight Net Approx.		243 lbs	320 lbs	397 lbs
Ambient Temperature		min. 68 °F max. 86 °F	min. 68 °F max. 86 °F	min. 68 °F max. 86 °F
Relative humidity		max. 60%	max. 60%	max. 60%
Noise level (at workplace)		<70 dB(A)	<70 dB(A)	<70 dB(A)
Voltage		1~ 208 V	1~ 208 V	1~ 208 V
Frequency		50/60 Hz	50/60 Hz	50/60 Hz
Max. nominal Current		7.1 A	10.1 A	13.4 A
Plug		NEMA 6-20P	NEMA 6-20P	NEMA 6-20P
Length power cord approx.		8 1/3 ft	8 1/3 ft	8 1/3 ft

<b>Model</b>	<b>MCC</b>	<b>24-3-H SS</b>	<b>36-3-H SS</b>	<b>48-3-H SS</b>
Approved for		USA / CAN	USA / CAN	USA / CAN
Width		23 5/8 in	35 7/16 in	47 1/4 in
Depth		29 1/2 in	29 1/2 in	29 1/2 in
Height on stand		55 7/8 in	55 7/8 in	55 7/8 in
Height above worktop		33 1/16 in	33 1/16 in	33 1/16 in
Weight Net Approx.		298 lbs	375 lbs	452 lbs
Ambient Temperature		min. 68 °F max. 86 °F	min. 68 °F max. 86 °F	min. 68 °F max. 86 °F
Relative humidity		max. 60%	max. 60%	max. 60%
Noise level (at workplace)		<70 dB(A)	<70 dB(A)	<70 dB(A)
Voltage		1~ 208 V	1~ 208 V	3~ 208 V
Frequency		50/60 Hz	50/60 Hz	50/60 Hz
Max. nominal Current		9.5 A	13.7 A	13.5 A
Plug		NEMA 6-20P	NEMA 6-20P	NEMA 15-20P
Length power cord approx.		8 1/3 ft	8 1/3 ft	8 1/3 ft

**Full-service and Self-service Humidified models**

<b>Model:</b>	<b>MCC</b>	<b>24-2-H FS / SS Hum.</b>	<b>36-2-H FS / SS Hum.</b>	<b>48-2-H FS / SS Hum.</b>
Approved for		USA / CAN	USA / CAN	USA / CAN
Width		23 5/8 in	35 7/16 in	47 1/4 in
Depth		29 1/2 in	29 1/2 in	29 1/2 in
Height on stand		55 7/8 in	55 7/8 in	55 7/8 in
Height above worktop		20 1/2 in	20 1/2 in	20 1/2 in
Weight Net Approx.		243 lbs	320 lbs	397 lbs
Ambient Temperature		min. 68 °F max. 86 °F	min. 68 °F max. 86 °F	min. 68 °F max. 86 °F
Relative humidity		max. 60%	max. 60%	max. 60%
Noise level (at workplace)		<70 dB(A)	<70 dB(A)	<70 dB(A)
Voltage		1~ 208 V	1~ 208 V	1~ 208 V
Frequency		50/60 Hz	50/60 Hz	50/60 Hz
Max. nominal Current		7.7 A	9.4 A	12.7 A
Plug		NEMA 6-20P	NEMA 6-20P	NEMA 6-20P
Length power cord approx.		8 1/3 ft	8 1/3 ft	8 1/3 ft
Water supply pressure <sup>1</sup>		150 — 600 kPa	150 — 600 kPa	150 — 600 kPa

<b>Model:</b>	<b>MCC</b>	<b>24-3-H FS/SS Hum.</b>	<b>24-4-H FS/SS Hum.</b>	<b>36-3-H FS/SS Hum.</b>	<b>36-4-H FS/SS Hum.</b>	<b>48-3-H FS/SS Hum.</b>	<b>48-4-H FS/SS Hum.</b>
Approved for		USA / CAN		USA / CAN		USA / CAN	
Width		23 5/8 in		35 7/16 in		47 1/4 in	
Depth		29 1/2 in		29 1/2 in		29 1/2 in	
Height on stand		55 7/8 in		55 7/8 in		55 7/8 in	
Height above worktop		33 1/16 in		33 1/16 in		33 1/16 in	
Weight Net Approx.		298 lbs	309 lbs	375 lbs	390 lbs	452 lbs	472 lbs
Ambient Temperature		min. 68 °F max. 86 °F		min. 68 °F max. 86 °F		min. 68 °F max. 86 °F	
Relative humidity		max. 60%		max. 60%		max. 60%	
Noise level (at workplace)		<70 dB(A)		<70 dB(A)		<70 dB(A)	
Voltage		1~ 208 V		1~ 208 V		1~ 208 V	
Frequency		50/60 Hz		50/60 Hz		50/60 Hz	
Max. nominal Current		7.8 A	7.8 A	9.4 A	9.5 A	12.7 A	12.8 A
Plug		NEMA 6-20P		NEMA 6-20P		NEMA 6-20P	
Length power cord approx.		8 1/3 ft		8 1/3 ft		8 1/3 ft	
Water supply pressure <sup>1</sup>		150 — 600 kPa		150 — 600 kPa		150 — 600 kPa	

<sup>1</sup> Humidified models only, when applicable.

Notes.

Fri-Jado B.V.  
Blauwhekken 2  
4751 XD Oud Gastel  
The Netherlands  
Tel: +31 (0) 76 50 85 400

Fri-Jado Inc.  
1401 Davey Road, Suite 100  
Woodridge IL 60517  
USA  
Tel: +1-630-633-7950

[www.frijado.com](http://www.frijado.com)