

SERVICE MANUAL

DELI MULTISSERIE

MODELS

Deli Multisserie with Grease Separator
Deli Multisserie with GS and condensor (shown).
Deli Multisserie with Grease Collector
Deli Multisserie with GC and condensor.



- NOTICE -

This manual is prepared for the use of trained Service Technicians and should not be used by those not properly qualified. If you have attended a training for this product, you may be qualified to perform all the procedures in this manual.

This manual is not intended to be all encompassing. If you have not attended a training for this product, you should read, in its entirety, the repair procedure you wish to perform to determine if you have the necessary tools, instruments and skills required to perform the procedure. Procedures for which you do not have the necessary tools, instruments and skills should be performed by a trained technician.

Reproduction or other use of this Manual, without the express written consent of Fri-Jado, is prohibited.



EMPTY PAGE

Versions		
Version	Issue date dd/mm/yy	Remarks
0706	06/2007	First release
1112	6/1/2012	Significant overall update.
1201	13/1/2012	changes on pages 38,53,66,76 regarding addition of pcb of 3-way valve
1701	31/1/2017	Service instructions included Error messages added in Trouble shooting Exploded views extended Electric diagrams updated
1704	10/4/2017	Grease container parts added on page 121 Soap and Rinse agent holder added on page 132 Several part numbers converted in "s" numbers
1709	11/9/2017	Rinse agent drawings page 83 and 138 adapted.

General technical data	6
Programming instructions	8
Display and keys	8
Setting the Multisserie	8
Add a program	9
Add a program	10
Program start.....	10
Pre heating	11
Loading with products	11
Program stop	12
Optional settings.....	13
Interrupting active program	13
Edit a program	13
Delete a program	15
Test program	15
Hidden possibilities	16
Switching off the Multisserie	16
The USB feature in the 9172552 board.....	17
USB communication and screen options	17
Software upgrade.....	17
Saving and loading files	18
Saving and loading cookbooks	19
Saving and loading parameters	19
Saving error history and/or haccp logs	20
Default parameters version 3.77	21
Default parameters version 6.00.06	23
Cleaning Program Multisserie	25

Service Procedures	26
Access to the Heater compartment	26
Exchanging the shaft seal	27
disassembling the blowers	27
Disassembling the shaft transit spacer.....	28
assembling the shaft transit spacer.	29
assembling the blowers	29
assembling the blowers (continued).....	31
exchanging a heating element	32
Replacement of a lamp	33
Disassembling the steam injection pipes and joints	34
Disassembling the water valves.....	36
Cleaning or renewal of water sprayers	37
Exchanging the side post pipe and sprayers.....	38
exchanging the Rotor column and central sprayer pipes	39
Exchanging the rotor motor	40
Exchanging the rotor shaft	40
exchanging vent parts	42
exchanging the PT1000 temperature sensors	44
exchanging the 3 way drain valve	46
exchanging the emergency switch	48
exchanging the doorswitches	49
exchanging the doors and door parts.....	50
Exchanging soap injection parts.....	54
Electrical tests.....	56
Measuring on the Blower circuit (From May 2014)	56
Measuring on the Blower circuit (Untill May 2014, unless updated)	59
Measuring on the 3 way valve.....	63
Measuring on the heaters	66
Measuring on the illumination.....	67
Measuring on the Rotor motor	67
Measuring on the Compressor.....	67
Measuring on the watervalves.....	68
Measuring on the airvalve (vent)	68
Measuring on the safety circuit.....	68
Measuring on the PT1000 sensors.....	69
Service Instructions.....	70
Service set CPU board 9172552s	70
Speed transformer upgrade kit 9190193s	74
Soap bottle cap.....	76
Service Set 9190131 , Soap bottle cap	77
Service Set 9191292s , revision of soap mister	78
Hinge repair kit 9190565	81
Rinse Agent Kit 9190198s	82
Repair of Blower motor connection block.....	84
Conversion to new motor connection block.....	85

Conversion to left controls	86
Service kit 9190171, Doorgasket channel repair.....	88
Service kit 9190173, mounting SS gutters.....	92
Condenser Hood	95
General Description	95
Access to service parts	97
Exchanging parts	99
Trouble shooting Hood	101
Troubleshooting	102
Communication between the Electronic Boards	103
Troubleshooting by Symptom	104
Troubleshooting by Part / Function	106
Exploded views & partlists.....	110
Electrical parts	110
Doors	112
Water and steam system	114
Blowers and heating.....	116
Rotor drive system	118
Drain and vent system	120
Soap injection system	122
Underframe (untill ser nr. 100055089, september 2011)	124
Underframe (from ser nr. 100055090, October 2011).....	126
Underframe (build-in).....	128
Chassis and sheet metal	130
Underframe 2017	132
Grease Separator.....	134
Internal condenser	136
Rinse kit.....	138
Bake.....	140
Fasteners	142
miscellaneous	143
Electrical diagrams	146
Circuit diagram 1 of 2 untill 2015.....	146
Circuit diagram 2 of 2 untill 2015.....	147
Wiring diagram 1 of 2 untill 2015	148
Wiring diagram 2 of 2 untill 2015	149
Circuit diagram 1 of 2 from 2016.....	150
Circuit diagram 2 of 2 from 2016.....	151
Wiring diagram 1 of 2 from 2016.....	152
Wiring diagram 2 of 2 from 2016.....	153

This manual covers the Fri-Jado Deli Multiserie ovens. All of the information, illustrations and specifications contained in this manual are based on the latest product information available at the time of printing.

TECHNICAL DATA

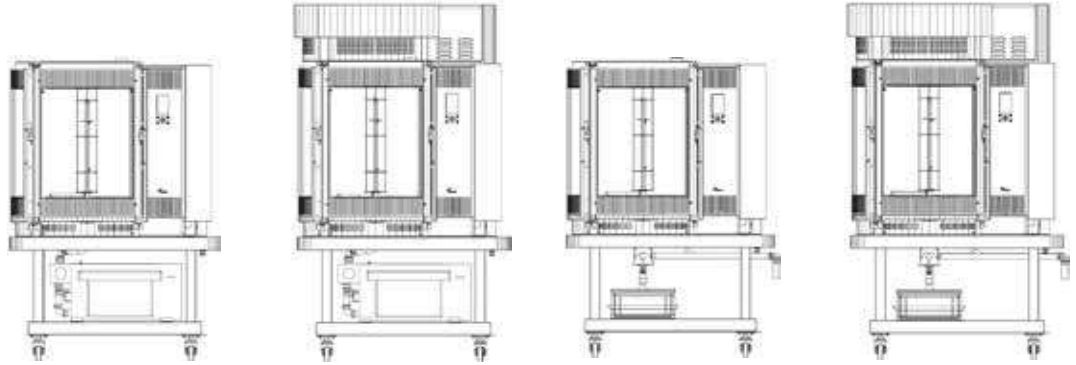

Type	Deli Mts. with GS	Deli Mts. with GS and IC	Deli Mts. with Bag in Box	Deli Mts. with Bag in box and IC
Net weight	390 kg 860 LBS	465 kg 1025 LBS	360 kg 794 LBS	435kg 959 lbs.
Gross weight	505 kg 1113 LBS	595 kg 1312 LBS	475 kg 1047 LBS	565kg 1246 lbs.
Height	74 1/4"	87 7/32"	74 1/4"	87 7/32"
Width	39 3/16"	39 11/16"	39 3/16"	39 11/16"
Depth	52"	52 13/16"	52"	52 13/16"
Voltage	208/120 V	208/120 V	208/120 V	208/120 V
Phase	3 (5wire)	3 (5wire)	3 (5wire)	3 (5wire)
Power	21.4kW	21.4kW	21.4kW	21.4kW
Breaker	80A (3 phase)	80A (3 phase)	80A (3 phase)	80A (3 phase)
Frequency	60Hz	60Hz	60Hz	60Hz

Warning: all electrical connections must comply with local codes.

Additional Grease separator				
Power	n/a (Through Multiserie)			
Water connection	n/a (Through Water heater)			
Drain	2"			
Additional Water heater				
Voltage	208V			
Phase	2 (3 wire)			
Power	2,9kW			
Breaker	20A			
Frequency	60Hz			
Water connection	n/a (G 3/4" through Multiserie (steam&rinse))			
Water drain			2" Open connection (aerated)	

WATER REQUIREMENTS

Water connection Wash	G 3/4" aerated
Water pressure	Minimum 3 Bar at 15 ltr/min / 40 Psi at 4 Gallon / minute Maximum 6 Bar at 15 ltr/min / 90 Psi at minimum 4 Gallon / minute
Water temperature	Maximum 70°C / 158°F
Acidity	pH 7.0-8.0
Chlorides	< 30 ppm
Water connection Steam & Rinse (S&R)	G 3/4" aerated
Hardness	Maximum 2 Grains / Gallon (preferably zero!)
Temperatur range	20-250°C / 122-482°F
Ambient temperature	Maximum 35°C / 95°F
Cleaning agent	

Use sediment pre-filter or a strainer for the reduction of silica and other non-dissolved sediments plus an active carbon pre-filter for the reduction of chlorine. In case of water hardness of 2 grains per gallon or more, use a decalcifying filter for reducing calcium and put the by-pass on ZERO. Contact your local water supplier for details regarding water quality.

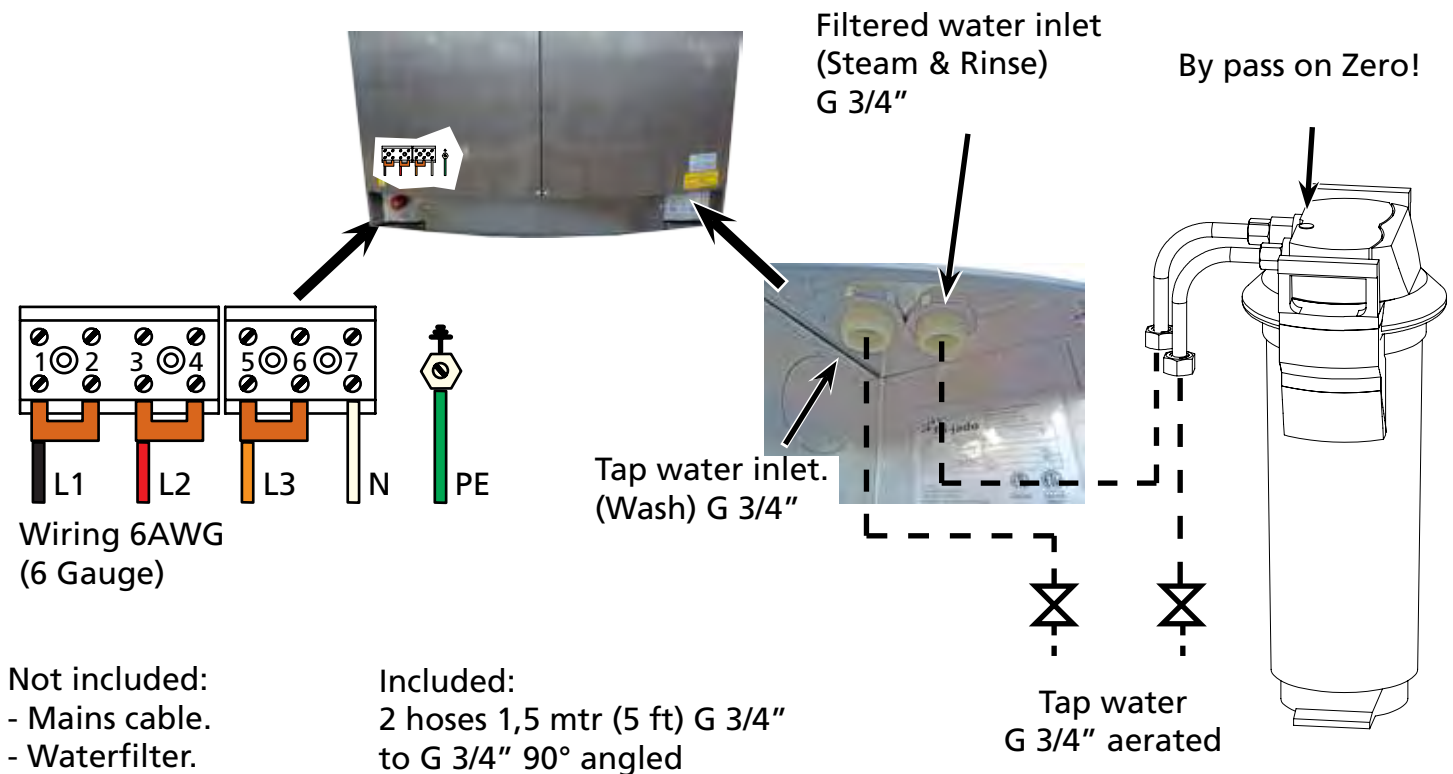

Warning: all plumbing connections must comply with local sanitary, safety and plumbing codes

DISPLAY AND KEYS

Program tab

Operate tab

Switching OFF
Press both keys for 3 seconds.

Start / pause of program

Switching ON
Press for 3 seconds
-Press 6 seconds for key test.

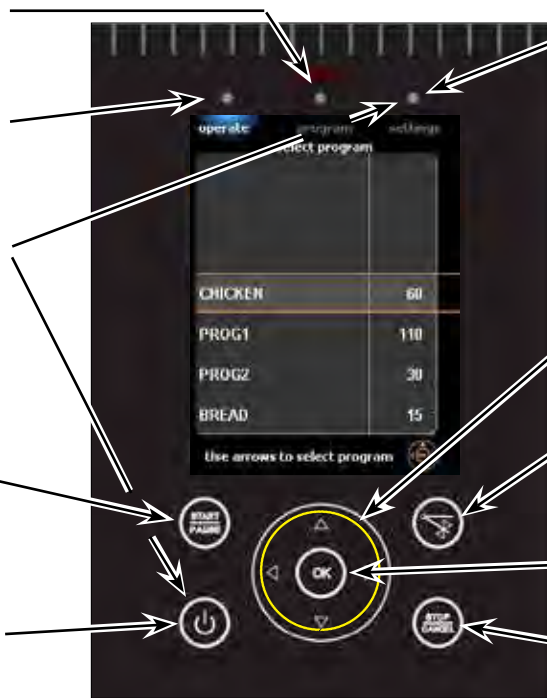

Settings tab

Combination of dial and up - down - left - right keys

-Rotor key for positioning rotor
-Door open key in BSi

Confirmation or entering of choice.

Stop / cancel of program

SETTING THE MULTISSERIE



Press and hold the On/Off key during 2 seconds. The display lights up and the multisserie is ON.



ADD A PROGRAM

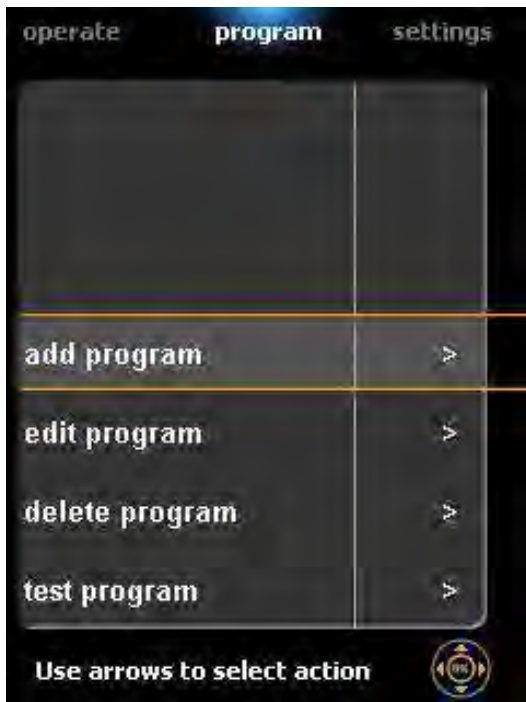

Press program key.

Note: when a pincode has been set, first enter the pincode and confirm with OK.

Add program by using the dial and confirm with OK.

Edit the program name by using the dial and press OK twice to confirm.



ADD A PROGRAM



Select time table with the dial and press OK to edit. Set the time of the cooking step and press OK to confirm.

Repeat this for:

Temperature.

Fan speed.

Steam mode.

Steam quantity.

Vent position.

Note that the first column, the core probe temperature, can be disabled in the service menu!

Program next cooking step if necessary.

Program temperature HOLD if necessary.

- Select next time table and set this on HOLD.
- Select temperature table and put in the hold temperature.

Go to save program and press OK to confirm.

PROGRAM START



Press operate key.

Select program with the dial and confirm with OK.

When no pre heating is activated, process starts and is indicated by means of a moving yellow circle.

PRE HEATING



When preheating step is activated in manager menu, the multisserie will start up with the preheat program after the program start. After reaching the preheat temperature the display will indicate: load products.

LOADING WITH PRODUCTS

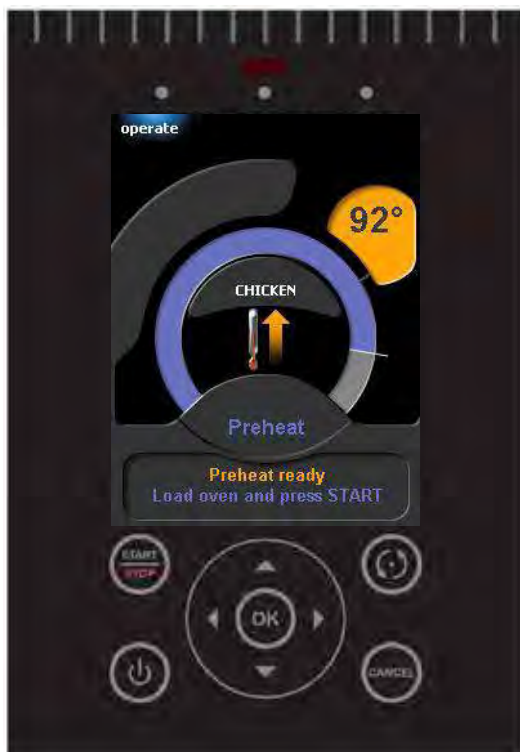

Press rotor key to put the rotor in the good position.

Load the multisserie with products

Close the door and press the start key.

PROGRAM STOP

Press cancel key.

Select yes with the dial and confirm with OK.

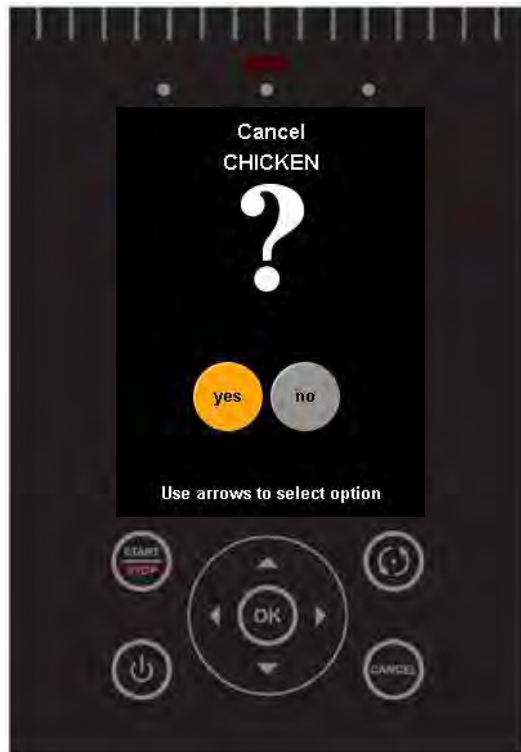

OPTIONAL SETTINGS

- Interrupting active program.
- Editing a program.
- Deleting a program.
- Running in test program.
- Demo mode.

INTERRUPTING ACTIVE PROGRAM



Press start/stop key. Heating, blowers and rotation stops.

Press start/stop key again to resume.

EDIT A PROGRAM



Press program key.

Note: when a pincode has been set, first enter the pincode and confirm with OK.

Go to edit program with the dial and confirm with OK.

Now change the name if necessary and confirm with OK.

Now change time and temperature if necessary. Then go to save program and confirm with OK.

Time.

In the first line (step), time is adjustable from 1 until 240 minutes, or "PRE" (preheat).

In the second step, there is also a possibility to put the time on "HOLD". The program will run until the <Stop> key is being pushed.

Temperature.

The temperature is adjustable from 0 until 250°C (482°F).

Core probe.

The cooking step elapses when the adjusted temperature is reached.

Fan speed. (In Multiserie, STO and BSi)

The fan speed is adjustable in 1 and 2 (low and high speed).

Steam.

The Multiserie has a various steam possibility. 60 different quantities in 3 modes. It will be explained below.

Vent. (exhaust)

This valve can be closed or opened in each step. From 2017, this valve has been removed.

Explanation of the steam system.

Steam is made by dripping water on the blower turbines. The turbines throw the water on the heaters and then it evaporates into steam.

The water quantity is controlled by one or more solenoid valves. By shortly (0,1 second) opening the solenoid valve, small amounts of water come through. Shortly opening the solenoid valve is called a (steam) pulse. So far, it is the same for all units.

Programming steam in the Multiserie and the BSi.

The steam quantity in the cooking program can be adjusted from 1 until 60 (pulses) in steps of 1. This can be done in 3 different modes.

The diagrams show examples of cooking steps of 2 minutes with a steam setting of 5 in the 3 different modes. (5 pulses in mode 0, 1 and 2)

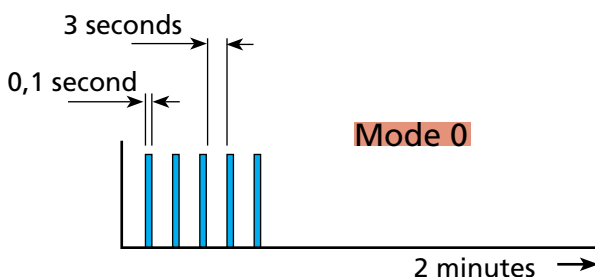

Mode 0.

This mode is meant for Bake off products. Only a small amount of steam is used at the beginning of the baking step.

The 5 pulses come at the beginning of the step with an interval of 3 seconds. The Pulse width and interval are adjustable in the service parameter settings

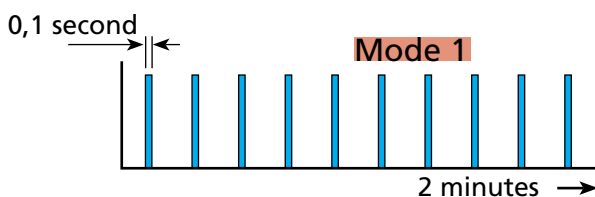

Mode 1.

This mode is used in case a cooking step is needed with a certain humidity during this step.

In this case the 5 pulses come per minute.

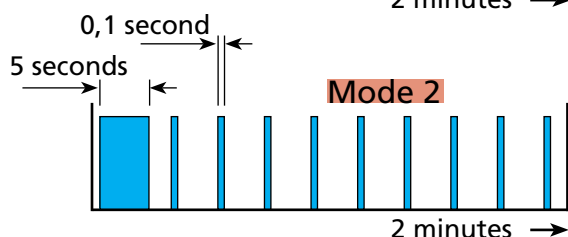

Mode 2.

This mode is the same as mode 1. Except for the first pulse. This pulse is much larger.

This mode is used for very delicate products to ensure that the oven cavity is filled up with steam in the first seconds of the cooking process.

DELETE A PROGRAM



Press program key.

Note: when a pincode has been set, first enter the pincode and confirm with OK.

Go to delete program with the dial and confirm with OK.

Now select the program to delete and confirm with OK.

Select yes with turning knob and confirm with OK.

TEST PROGRAM



In the test program you can run a program and you have the possibility to change time and temperature during the process.

Press program key.

Note: when a pincode has been set, first enter the pincode and confirm with OK.

Go to test program with the dial and confirm with OK.

Now select the program and confirm with OK.

If you press the OK key during the program you can change the settings.

Go to save program and confirm with OK.
New settings are now saved.

HIDDEN POSSIBILITIES

Demo mode.

The controller has a so called "Demo Mode". See parameter "demo mode" in the chapter "parameter listings".

In this demonstration mode, the heating of the unit is disabled and will simulate the machine heating up, only through software. All other functions are still active.

Continues rinse.

It is also possible to have a continues rinse.

To achieve this, the unit has to be set to "demo mode" first.

After that and switching the unit OFF and ON, the "ON/OFF" and "Programs" key have to be pushed together for 3 seconds.



SWITCHING OFF THE MULTISSERIE

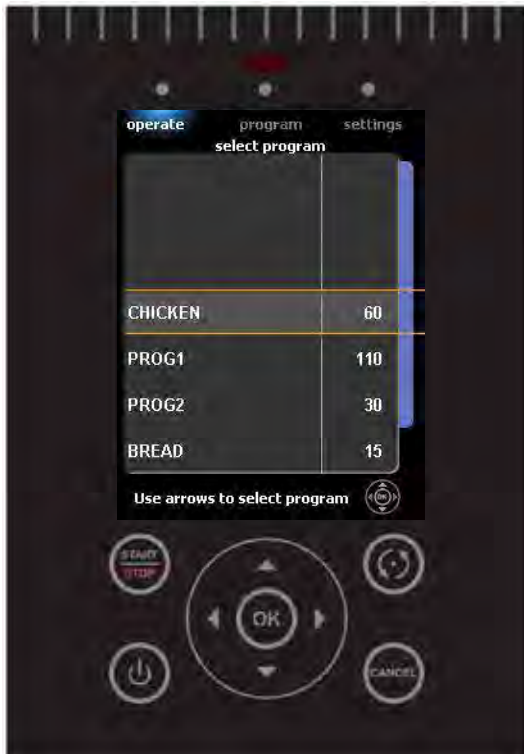

Press and hold both keys On/Off and settings until the display light goes out and the rotisserie is OFF.

Since software version 5.02.07, switching OFF can be done with only the On/Off key.

THE USB FEATURE IN THE 9172552 BOARD.



Mini USB port

USB port

- From the first release in November 2012, it was possible to upgrade the sw version by means of a USB stick.
- From V5.00.14, recipes can be exchanged by means of a USB stick. This is a temporary solution and will only function in case of the same software version. (also the same device type).
- From V5.01.03, USB communication is available for saving and loading files, but also this was temporary.
- From V5.02.07, June 5th 2015, communication has been made more convenient. Files from version V5.01.03 can be used in this version.

USB COMMUNICATION AND SCREEN OPTIONS



Press <settings>.

There are three different options in this screen, "information", "manager" and "service".

To access the different sections, select an option using the dial or up and down keys and confirm with <OK> .

To leave a section use the "cancel" key.

Note: The service section is by default protected with the password (pin code) "4878".

Note: The manager section can be protected by a separate password, this password can be set inside the manager menu. It is possible to view this password through the service menu.

SOFTWARE UPGRADE

How to read out the software version (firmware).

1. Switch ON the unit. (push 3 sec.)
2. Push the <settings> tab.
3. Select "information"
4. Read out the version

Updating systemsoftware (firmware).

- This software can be found and downloaded from the Frijado website and can also be sent by e-mail as an attachment.
- It comes in a "zip" file with the version number of the software, for example "V5_01_03.zip". The file needs to be copied on a USB stick. (disk "STORE N GO (F:)" in the example)
- After unpacking it, the folder named "42-I+CPU" needs to be moved or copied to the root of the USB stick as shown below.



Now proceed as follows:

1. Switch OFF the mains supply or pull the mains plug.
2. Connect the usb stick.
3. Switch the power back on or put the mains plug back in. You will see that the controller detects the software and starts uploading
4. You will be asked to remove the stick and when done the unit switches off. (the existing parameters will remain).
5. **In case the board has just been put into a unit, it has to be set to the right device type!!!!** This has to be done in the service menu. Refer to the chapter "parameter settings.

SAVING AND LOADING FILES

Since software version V5.02.07 it is possible to load and save files on a USB stick

The possibilities are:

- Load and save cook book
- Load and save parameter file
- Save Error history
- Save HACCP log

All cook books (also called recipes or programs) that are saved come automatically in a folder named "PROGRAMS", which is placed in the root of the USB stick.

All (external) cook books that need to be loaded into the unit, need to be placed in the same "PROGRAMS" folder.

Saving and loading cookbooks has to be done in the Manager menu.

Saving and loading parameters and saving error history or haccp logs has to be done in the Service menu.

For parameters, the folder "PARAMS" is used.

For error history and HACCP log, the folder "LOG" is used.

SAVING AND LOADING COOKBOOKS

Insert the USB stick in the socket.

Push <settings> --> manager--> Pincode optional

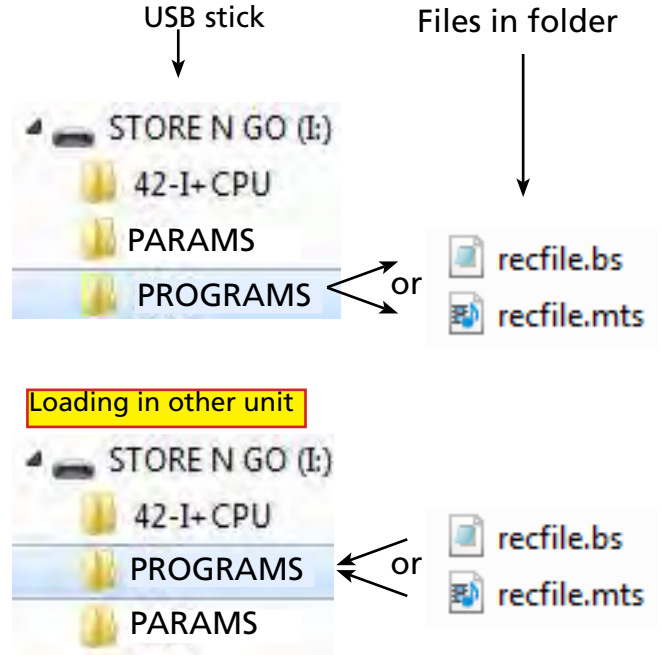
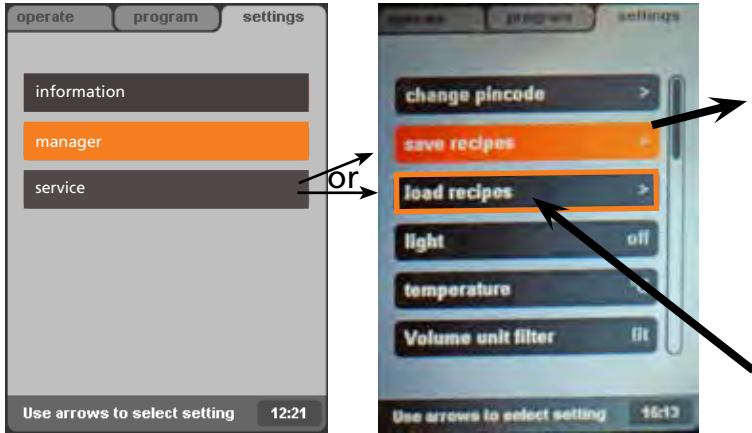

Explanation of file names and folders.

- The folder "PROGRAMS" is used for **loading AND saving** of recipes (cookbooks).
- This folder will be automatically made when saving recipes.
- The name of the file can be chosen freely, for example "recfile"
- File extensions are related to the device type. Examples:
- .bs = Bake Star
- .mts = Multiserie
- .acr = Auto Clean rotisserie

SAVING AND LOADING PARAMETERS

Insert the USB stick in the socket.

Push <settings> --> service --> Pincode 4878

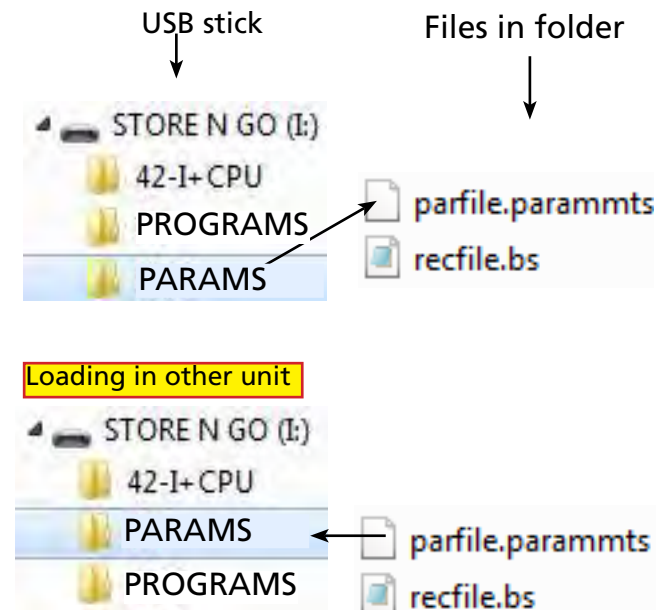
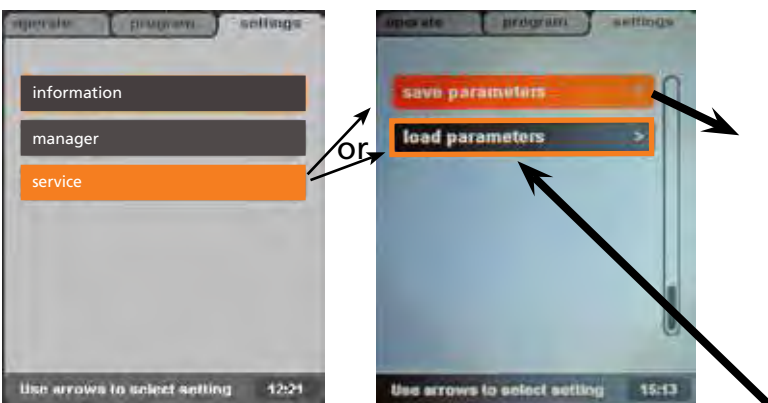

Explanation of file names

- The folder "PARAMS" is used for **loading AND saving** of parameters.
- This folder will be automatically made when saving parameters.
- The name of the file can be chosen freely, for example "parfile"
- File extensions are related to the device type. For example ".mts" = Multisserie

SAVING ERROR HISTORY AND/OR HACCP LOGS

Insert the USB stick in the socket.

Push <settings> --> service --> Pincode 4878

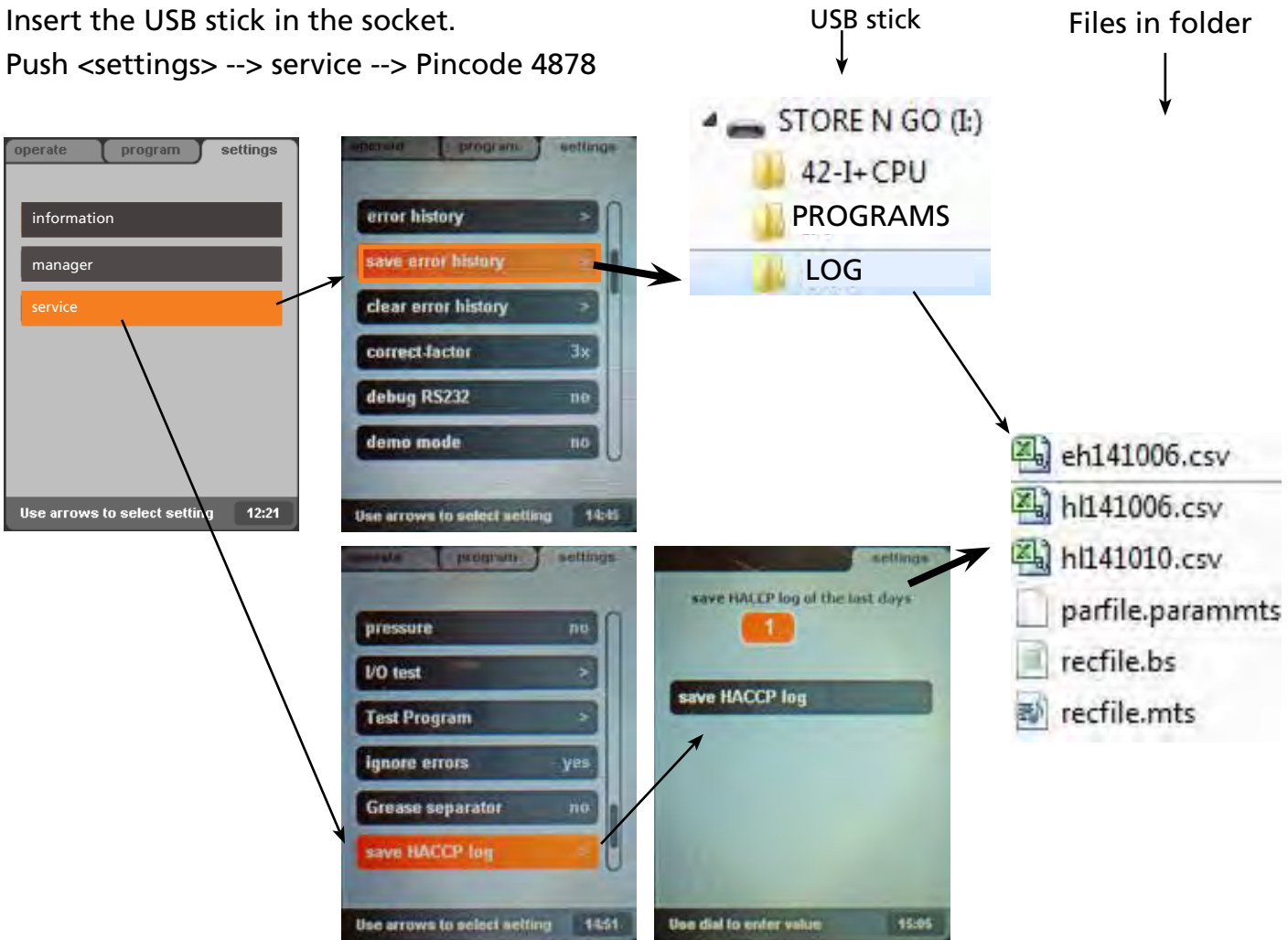

Explanation of file names

- eh141006 => error history, date October 6th, 2014
- hl 141010 => haccp log , date October 10th, 2014
- These files are placed in one folder, named "LOG" since sw V5.02.07. !!

DEFAULT PARAMETERS VERSION 3.77

Level 1	Level 2	Level 3	Default	Possibilities
Information			3.77	software version
Manager				
	Change Pin code		0000	0000 - 9999
	Light		on	on - off
	Temperature		°C	°C - °F
	Set time		Local time	
	Set date		Actual date	
	Set contrast		80	35 - 105
	Time format		24 hr	24 hr - AM/PM
	Date format		DMY	DMY - MDY
	Alarm signal		yes	no - yes
	Preheat mode		no	no - 1x - yes
	Preheat delta		0	-50°C to + 50°C or -90°F to +90°F
	Auto recipe start		yes	no - yes
	Buzzer set		0	0 - 4
	Key beep		yes	no - yes
	lime filter			remaining capacity of lime filter
	lime filter replaced		no	no - yes
	Clear error			no - yes
Service			4878	
	device type		Multi	STGi, Multi, M-Bake, BSi, STOi
	Condensor		No	no - yes
	auto-correct		time	no - time
	set language		englisch	englisch - deutsch - francais - nederlands - espanol - japanese
	IrDA interface		no	no - yes
	IP Network	IP address	192.168.0.40	192.168.0.10 - 192.168.0.249
		IP netmask	255.255.255.0	none
		IP gateway	192.168.0.250	none
		auto IP / DHCP	no	no - yes
	NAFEM option		no	no - "password"
	alarm delays	alarm	3 sec.	1 - 17
		alarm	5 min.	1 - 60
	Pulse timing		5 sec.	0,1 - 10
			3 sec.	1 - 10
			0,1 sec.	0,1 - 1
	Heater delta		0°C	-30°C to + 30°C or -54°F to +54°F
	Manual operation		No	no - yes
	correct-factor		3x	1x - 10x
	debug rs232		no	no - yes
	demo mode		no	no - yes
	Temp. probe		yes	no - yes
	auto off		60	no or 10 - 240
	pin code		****	read out of the manager pin code
	Sensor offset		0°C	-5°C - +5°C
	drain feedback		yes*	no - yes

Level 1	Level 2	Level 3	Default	Possibilities
	Clean timing	Adding clnr	8 min.	0 - 10
		Dry soak	10 min.	0 - 30
		Wet soak	30 min.	0 - 60
		Rinsing	4 min.	0 - 10
		Drying	30 min.	0 - 60
	Cold flush time		60	10 - 60
	complete cleaning		yes	no - yes
	PID factors	P	100	0 - 100
		I	5	0 - 100
		D	50	0 - 500
		iMax	100	
		Relay actions	100	10 - 300
	Energy	Volts	230	1 - 260
		Model	M_Meat	none
	Water hardness		8	-, 4 - 35
	Pressure		no	no - yes
	I/O test			read inputs and set outputs
	Ignore errors		no	no - yes

DEFAULT PARAMETERS VERSION 6.00.06

Level 1	Level 2	Level 3		Default	Possibilities
Information				6.00.06	software version
Manager					
	Change Pin code			0000	0000 - 9999
	Save Recipes				save cookbook to USB
	Load Recipes				load cookbook from USB
	Light			on	on - off
	Temperature			°C	°C - °F
	Volume unit filter			lit	lit-gal
	Set time			Local time	
	Set date			Actual date	
	Time format			24 hr	24 hr - AM/PM
	Date format			DMY	DMY - MDY
	Alarm signal			yes	no - yes
	Preheat mode			no	no - 1x - yes
	Preheat delta			0	-50°C to + 50°C or -90°F to +90°F
	Auto recipe start			yes	no - yes
	Buzzer set			0	0 - 4
	Key beep			yes	no - yes
	water capacity filter			-	50 - 30000 or "-" for infinite
	Lime filter				Remaining capacity of lime filter
	Lime filter replaced			no	no - yes
	Clear error				no - yes
Service				4878	
	device type			Multi	STGi, Multi, M-Bake, BSi, STOi
	condensor			no	yes - no
	auto-correct			time	no - time
	set language			englisch	englisch - deutsch - francais - nederlands - espanol - japanese - danish - italiano
	alarm delays	alarm	T4	3 sec.	1 - 17
		alarm	T5	5 min.	1 - 60
	Pulse timing		T1	5 sec.	0,1 - 10
			T2	3 sec.	1 - 10
			T3	0,1 sec.	0,1 - 1
	Heater delta			25	-30°C - +30°C
	manual operation			no	yes - no
	error history				overview of last 200 errors
	save error history				saving error history on USB
	clear error history				
	correct-factor			3x	1x - 10x
	debug rs232			no	no - yes
	demo mode			no	no - yes

Level 1	Level 2	Level 3		Default	Possibilities
	temp probe			yes	no-yes
	auto off			60	no or 10 - 240
	pin code			****	read out of the manager pin code
	Sensor offset			0°C	-5°C - +5°C
	drain feedback			yes*	no-yes
	Clean timing	Adding clnr	T21	8 min.	0 - 10
		Dry soak	T22	10 min.	0 - 30
		Wet soak	T23	0 min.	0 - 60
		Rinsing	T34	4 min.	0 - 10
		Drying	T25	4 min.	0 - 60
	clean temp	Steam Temp		60°C/ 140°F	5°C - 120°C (41°F - 248°F)
		Dry Temp		70°C/ 158°F	5°C - 120°C (41°F - 248°F)
		Clean Temp		65°C/ 149°F	5°C - 120°C (41°F - 248°F)
	cold flush time**			25	10 - 60
	rinse option			no	yes - no
	complete cleaning			yes	no - yes
	delete all programs				yes - no
	PID factors	P		100	0 - 100
		I		5	0 - 100
		D		100	0 - 500
		iMax		100	10 - 300
		Relay actions		80	16 - 160
	Energy	Volts		230	1 - 260
		Model		M_Bake	none
	Pressure			no	no - yes
	I/O test				Read the inputs and set the outputs
	Ignore errors			no	no - yes
	grease separator			no	no-yes
	save HACCP log				save haccp on USB
	save parameters				save parameters on USB
	load parameters				load parameters from USB

*

The first units do not have a feedback on the drain valve. This is a signal that tells the processor that the valve is in the good position.

To find out if your unit has it, please follow the following steps:

Go to the I/O test menu (last item in the service menu) and enter it.

Go to the MFMB inputs item and press OK.

If the X30-31 or X16-17 item is "1" your machine has the feedback installed. The "drain feedback" parameter should be "yes".

If both X30-31 and X16-17 are "0" your machine does not have the feedback installed, the "drain feedback" parameter should be "no"

**Only visible of "condensor" is put on "yes".

CLEANING PROGRAM MULTISSERIE

PHASE	STEP					ADJUSTABLE IN SERVICE MENU
START	depending on how dirty it is.	extra dity uses 1 + 2 + 3 [CLEAN EXTRA]				
CLE-ANING		dirty uses 2 + 3 [CLEAN REGULAR]				
CYCLUS		not dirty uses 3 [CLEAN LIGHT]				
		only rinsing uses 3 from rinsing [RINSE]				
		1) first time	2) second time	3) third time		
	cooling down /	until temp.=65°C	until temp.=65°C	until temp.=65°C		not adjustable
	warming up	(pulses: 30/min 0.4 s)	(pulses: 30/min 0.4 s)	(pulses: 30/min 0.4 s)		
	cleaner ato- mised	800 ml	400 ml	265 ml		1st quantity: 0 – 10 min.
	(blower low)	8 min.	4 min.	2.7 min.		2nd quantity is 50% of 1, 3rd is 33% of 1
	soaking	10 min.	10 min.	10 min.		0 – 30 min. Each step
	(everything is switched off)					
	steam injecti- on. Adjusta- ble temp.	30 min. (45p/min., 0.1 s)	30 min. (45p/min., 0.1 s)	30 min. (45p/min., 0.1 s)		0 – 60 min. Each step 60°C - 115°C 140°F - 239°F
	rinsing	2 min. side post	2 min. side post	2 min. side post		0 – 10 min. Each step
		2 min.wash arm	2 min.wash arm	2 min.wash arm		(side post 50%, wash arm 50%)
						Usage 12ltr/min at two bar (flowing)
FINAL RINSE	rinsing	2 min. side post (optional filtered water)				not adjustable usage 10 ltr/min at 2 bar (flowing)
		1 min. wash arm (optional filtered water) 30 liters total				
END	drying	4 min., 70°C				0 – 60 min. 5°C - 120°C

WARNING: Disconnect the electrical power to the machine at the main circuit box. Place a tag on the circuit box indicating the circuit is being serviced.

ACCESS TO THE HEATER COMPARTMENT

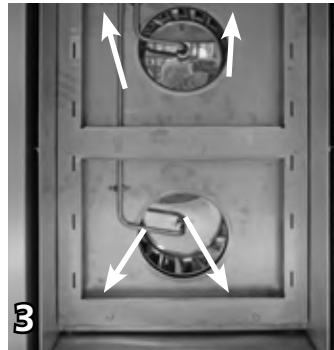

Note: numbers in brackets [] are positions on the exploded views

1. Remove all chicken racks and/or baskets.
2. Remove the fat filters [278]. Lift and take out.

Note that in case this is not possible due to carbon build up behind the filters, continue at point 3

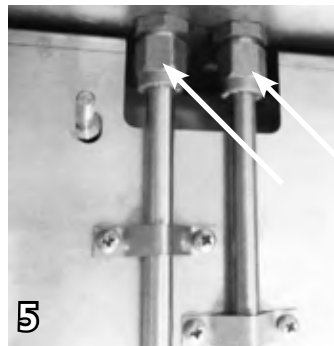

3. Remove the filter holder [275] (4 capnuts M6) [837]

4. Remove the 4 spacers [276].
5. Loosen the upper swivels from the water injection joints [227] with a 17mm wrench.

Hold the joint with a 19 mm wrench.

6. Take out the fan plate [277].

Note: In units manufactured before 2009, it might be necessary to remove the nut from the soap mister [450] and push it above the top plate.

Reverse the procedure to install.



EXCHANGING THE SHAFT SEAL

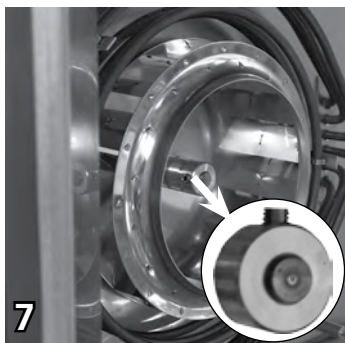

9191244s



Provide access to the blowers according the procedure above.

7. Loosen the socket set-screw from the blower blade at least 3 turns. (metric 4mm)
8. Pull the blade from the shaft . Maybe with help of a ball joint puller. See chapter "TIPS" in case of difficulties.

Note that the blower motor and fan blade need to stay together!

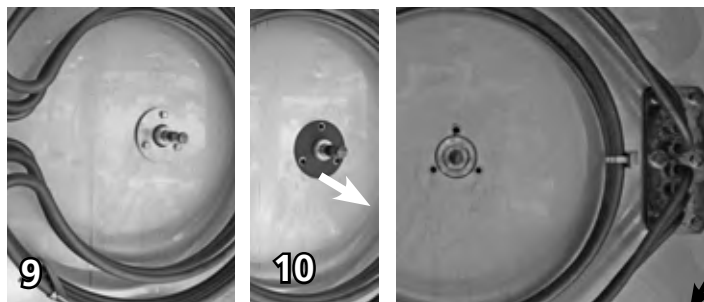

9. Unscrew 3 bolts M5 and remove the pressure plate [252].

See note !!

10. Remove the seal ring [253].

Note that older units can have a different shaft seal. In that case, just remove the seal and the adjusting ring.

Reverse the procedure to assemble.

Note that these bolts can be stuck in the aluminium spacer [254]. They will break in that case! Try to loosen them by heating the area up with a hot air gun. Be carefull with a gas fired torch!! To jerk the bolthead with a hammer might help too. Clean the thread (M5)!

DISASSEMBLING THE BLOWERS

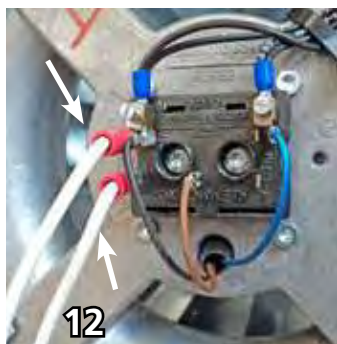

Disconnect the power supply first!

Remove the blower blade and shaft seal according prior procedure.

11. Open the service doors at the back. [551] [4 screws].
12. Disconnect the 2 capacitors [51] from the ventilator motors.
13. Take the hose with the grommet out of the transit hole.
14. Remove the vertical air suction channel. [268] (2 nuts M6 en 2x nut/bolt M5)
15. Unscrew the vane switch assembly [290] (2x M5 serrated bolt)

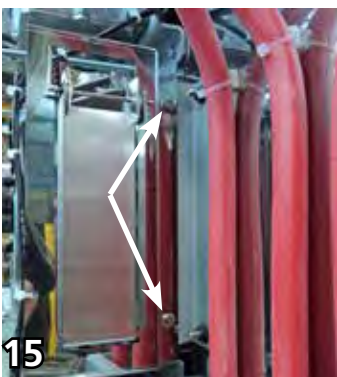
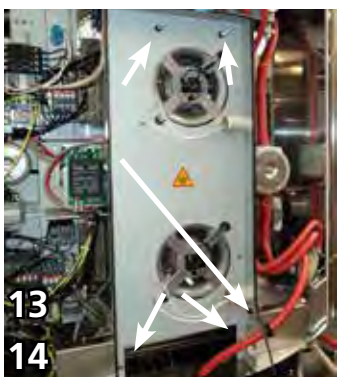

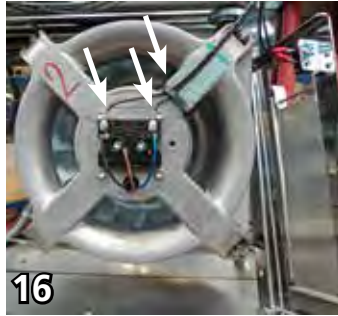

16. Disconnect the wiring from the 2 screw terminals on the blower motor(s) and cut the cable tie.

17. Remove the 4 nuts (M6 serrated) from the aluminium motor-housing and carefully take out the blower [50]. Repeat this if necessary with the other blower.

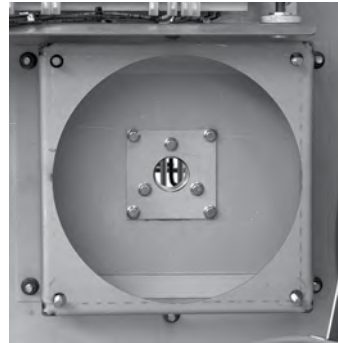
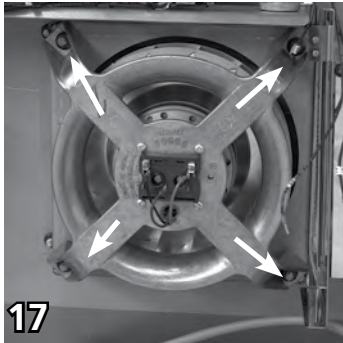

Refer to the concerning chapter to assemble the blowers.

Keep blower motor and fan blade together!!

DISASSEMBLING THE SHAFT TRANSIT SPACER.

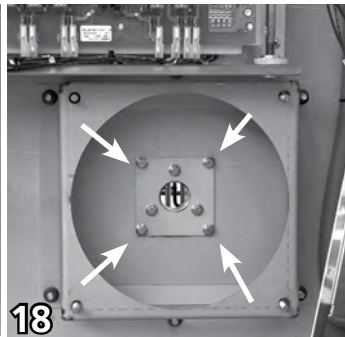
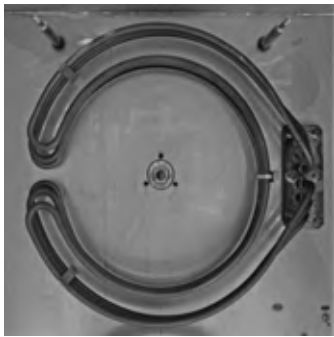

Remove the blowers and shaft seals according prior procedure.

On the backside.

18. Remove the 4 bolts (M5x10) on the corners of the mounting plate. [255].

19. Stab loose the mounting plate with a screw driver (or the like). (The spacer [254] is sealed at the front side with sealant and can possibly stick)

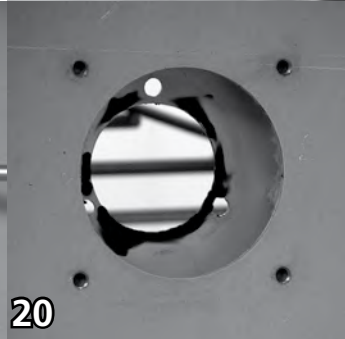

20. Pull the mountingplate with the spacer out of the hole.

21. Remove the mounting plate from the spacer (3 bolts M5x12).

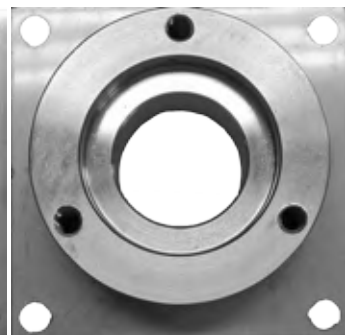

ASSEMBLING THE SHAFT TRANSIT SPACER.

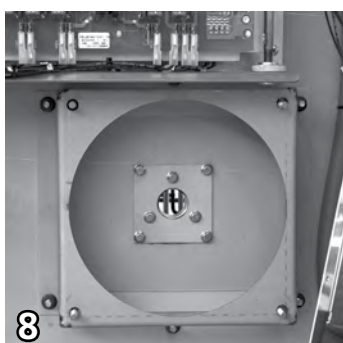
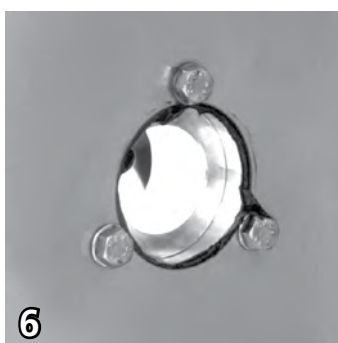
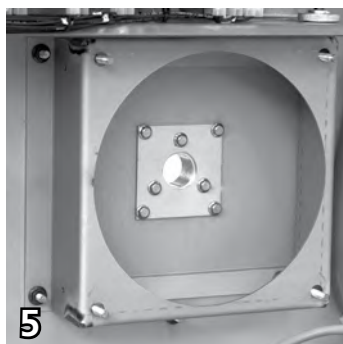
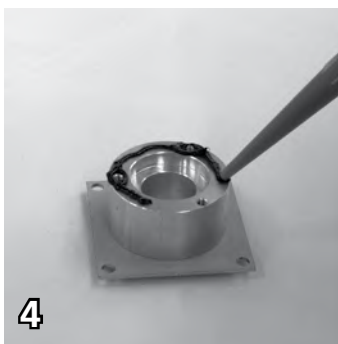
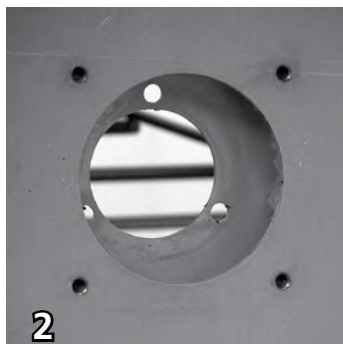

1. Clean and degrease the "old" spacer [254] or take a new one.
2. Clean and degrease the contact-surface from the spacer on the inner oven wall.
3. Mount the mounting plate half-fastened on the spacer (3 bolts M5x10 serrated).
4. Put a layer of heat resistant sealant (644°F) on the contact-surface.
5. Push the spacer on its place (1 bolt centre-up !) against the inner oven-wall and mount the 4 bolts half-fastened (M5x10 serrated).
6. Mount the 3 bolts on the inside and fasten them (M5x18).
7. Remove the redundant sealant with a cloth or the like.
8. Now fasten the 7 bolts at the rear.

ASSEMBLING THE BLOWERS

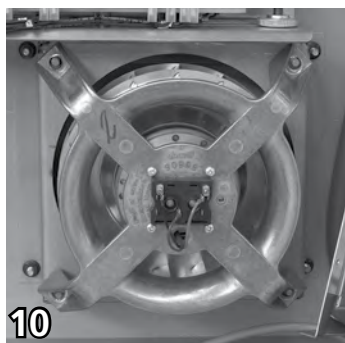
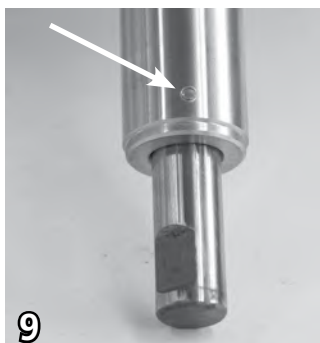

9. *Carefully clean the blower shaft. File away the damaging on the blower shaft caused by the socket set-screw of the adjusting ring in. (this only applies when the old shaft seal was from a previous model)*
10. Put the blower motor on its position and place the nuts. Not tight!! (M6 serrated black).

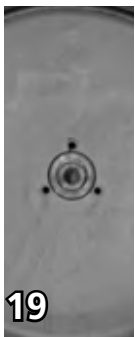
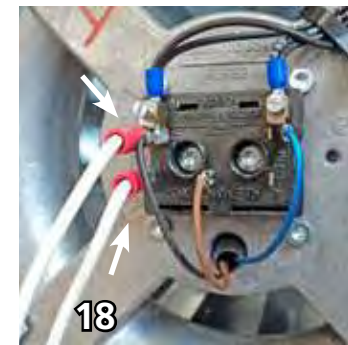
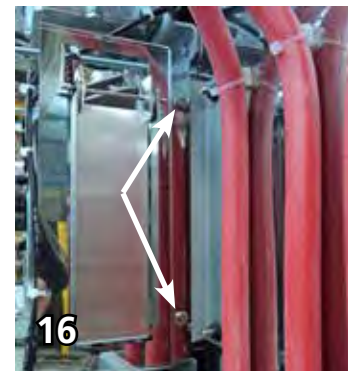
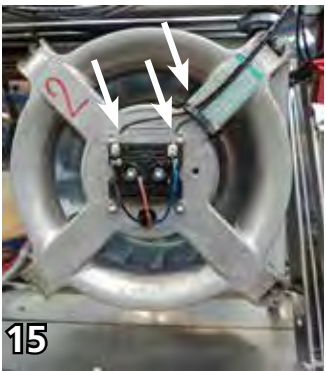
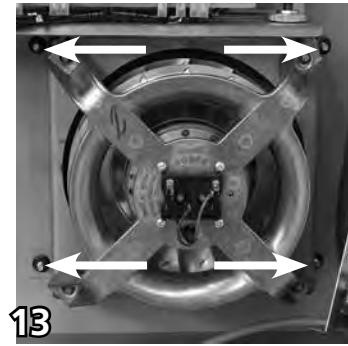
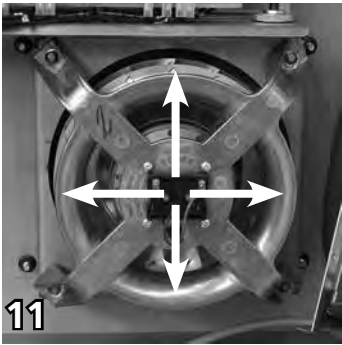

11. Put the blower in that position that the shaft comes through the centre of the hole of the spacer.
Note that occasionally it might be necessary to drill up the mounting holes to 3/8".
12. Fasten the 4 nuts. **Torque 6 lbf.ft**
13. Check the 4 nuts of the construction profile [267], with the same torque. In case these nuts moved, then repeat point 12.
14. Check if the shaft is still coming through the centre of the hole of the spacer.
15. Connect the wiring to the screw terminals of the blower motor and mount a new cable tie.
16. Mount the vane switch assembly [290]. (2x bolt M5x10 serrated)
17. Mount the vertical air suction channel and put back the grommet with the hose. (2 nuts M6 en 2x nut/bolt M5)
18. Connect the capacitor wiring to the blower motor.

On the inside:

19. Remove the 3 bolts (M5x18), if applicable.
20. Push a new seal [253] over the blower shaft and check if the 3 holes enable free access to the mounting holes. If not, then the blower shaft position is not good. Refer to point 11.
21. Mount the seal with the pressure plate [252] and 3 bolts M5x18 [824].
Torque 4 1/2 lbf.ft (6Nm)

ASSEMBLING THE BLOWERS (CONTINUED)

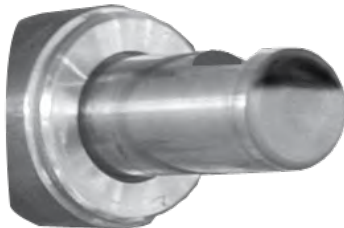

18. Mark the position of the flat surface on the shaft, on the shaft head.

19. Place the blade in such a way that the socket set-screw is positioned square to the flat surface on the shaft.

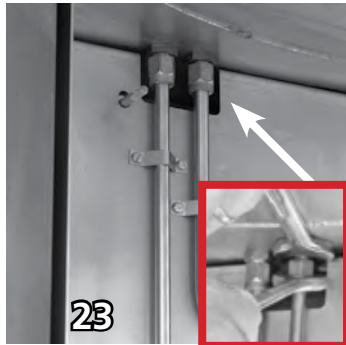
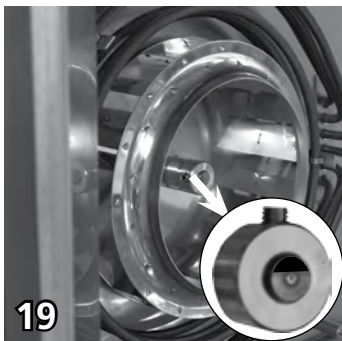

Keep blower motor and fan blade together!!

20. Slowly fasten the set-screw while the centre of the flat surface is searched by moving the ventilator blade with short left/right movements. Slide the ventilator blade as far as possible to the back on the shaft.

21. Fasten the screw.

22. Place the fan plate [277].

23. Fasten the swivels of the water injection-joints [227] while holding the joint with a 17 and 19mm wrench. Take care of the distance of the pipes to the ventilator shaft!! 1/4" - 3/8".

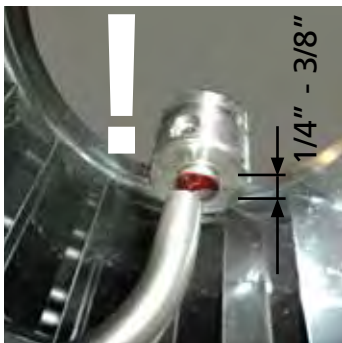

24. Place the 4 spacers [276] and mount the filter support [275] (4 nuts M6).

25. Place the fat filters [278].



Mount the nut from the soap mister [450] if applicable.

26. Put in the chicken racks and/or meat baskets.

EXCHANGING A HEATING ELEMENT

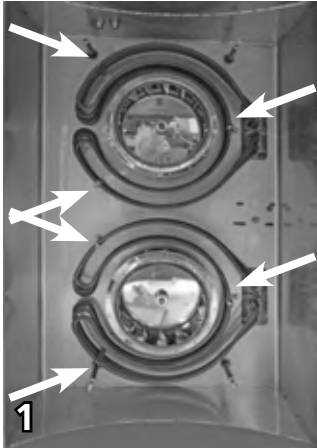

Gain access to the heater compartment as described in a previous chapter.

On the inside:

1. Remove 3 nuts M4 + washers.

On the backside:

2. Open the service doors at the back [551].
3. Remove the transparent safety panel. [573]
4. Check the presence of the numbering on the wiring of the heating elements and make a note of this.

Note that the numbers are laser marked on the wires (see example).

5. Pull the 6 wires from the heating element.
6. Unscrew 6 Nuts M6.

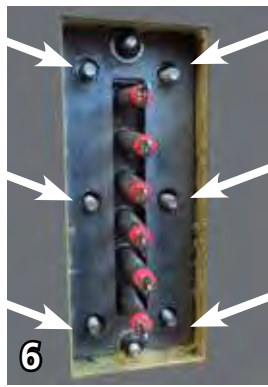
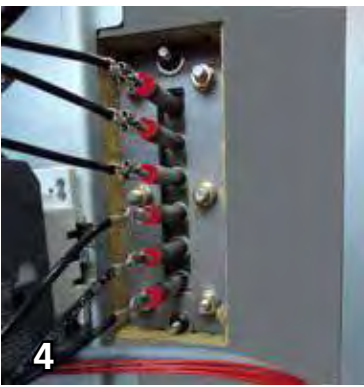

On the inside:

7. Take out the heating element.
8. Take out the gasket.
9. Clean the surface.

Example of wire numbers



Reverse the procedure to install.

- Take a new gasket!



REPLACEMENT OF A LAMP

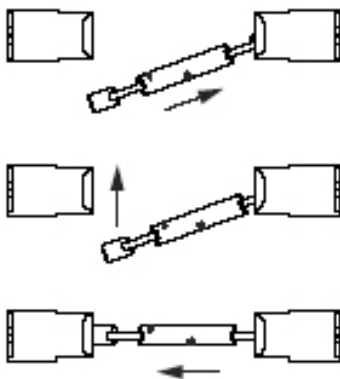
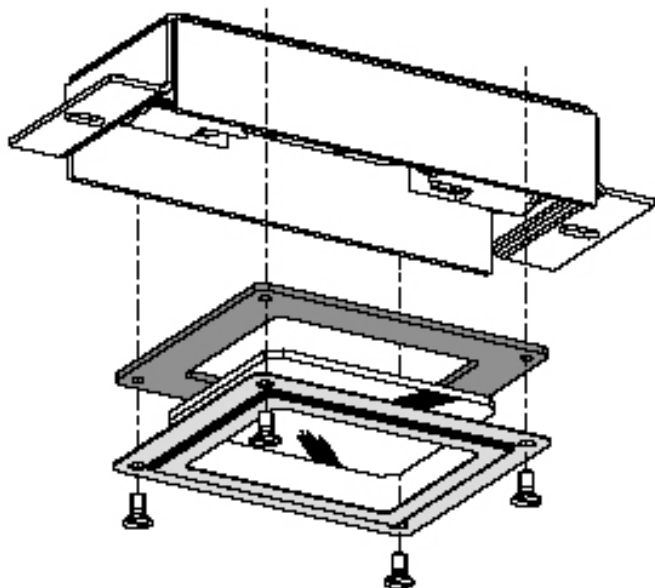

Notice: Do not touch the lamps with bare hands. Use a clean cloth or paper tissues when replacing the lamp. Remove any moisture with alcohol or methylated spirits after the lamp has cooled down.

1. Remove the plug from the wall socket.
2. Remove the 4 screws from the lamp holder. Beware, the frame, glass and gasket will come off at the same time.
3. Remove the lamp.
Push the lamp against the spring to one side of the lamp holder and pull it down.
4. Install a new halogen lamp (120 V – 150 W).
First press one side of the lamp into one connection point, then put the lamp properly in its place and have it spring into the other connection point (as showed).
5. Make sure the lamp is properly clamped between the two connection points.
6. Install the gasket, glass and frame.
7. Before fastening the screws completely, move the glass to the middle of the frame. It is the intension that the glass corners do not touch the edge.

DISASSEMBLING THE STEAM INJECTION PIPES AND JOINTS

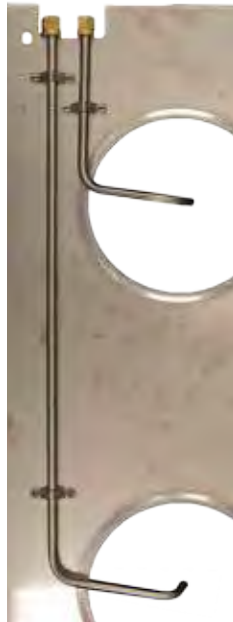

1. Gain access to the heater compartment as described in a previous chapter.
2. Check if the pipes [229 and 230] are open.
3. Try to drill out the holes with a 19/64" drill in case it is clogged with lime, or place new ones. (Carbide tipped drills might be the best choice, because lime can be like stone).
4. Check if the joints [227] in the top are open.
5. Try to drill out the holes with a 19/64" drill in case it is clogged with lime, or place new ones.



Exchanging the joints [227].



6. Open the service doors on the back.
7. Open the top of the unit. (9 screws)
8. Unscrew 7 screws M5x12 and 4 screws M5x 30 at the top-backside.
9. Check if the glass control panel and name panel cannot fall. It should be locked up behind the cover plates [559 and 563], see arrow. In case of doubt, lock them with tape or something
10. Remove the top plate.

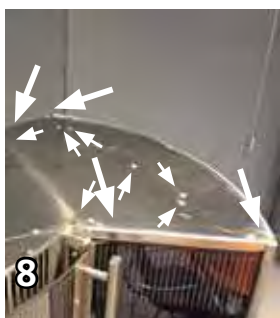



11

view from top



11. Unscrew the top swivels of the joints with a 17 mm wrench. It might be necessary to hold the body with a 19mm wrench from the inside of the unit.
12. Unscrew the nuts of the joints with a 19mm wrench and take out the joints.
13. Remove the hoses in case the angled pipes [226] need to be replaced.

Note that in case the joints [227] are ok and the pipes need to be replaced, loose clamp rings are available [228].



12



Loose clamp ring
3500144

DISASSEMBLING THE WATER VALVES.

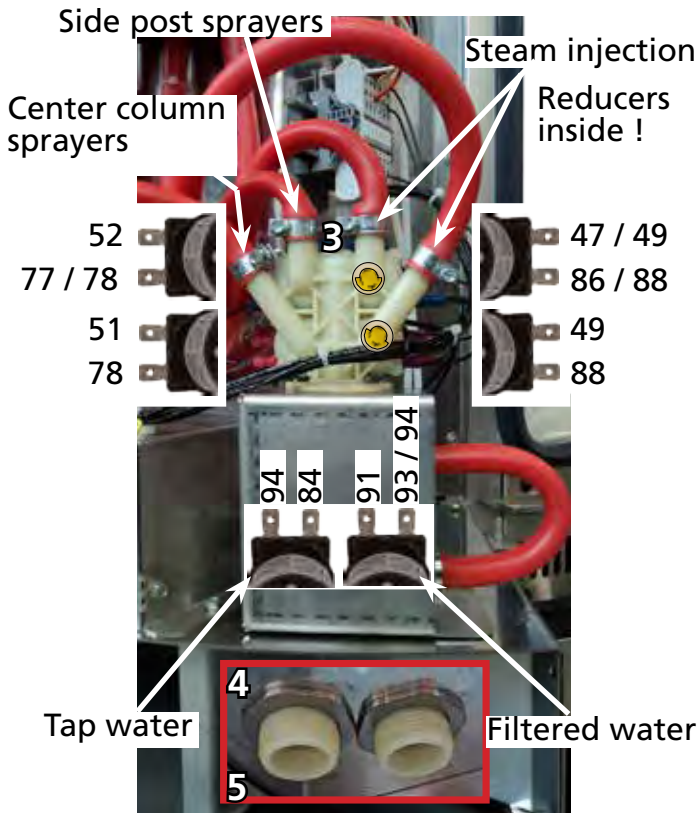

Disconnect the power supply first!

1. Open the service doors on the back.
2. Close the tap.
3. Disconnect the 4 hoses at the top.
4. Disconnect the supply water hoses.
5. Remove 2 sheet metal nuts 3/4".
6. Turn the assembly outwards and remove the wires from the valves. At the same time check the wire numbers on it with the over-view.

Note that 2 valves have (yellow) reducers inside !!

In case dirt came inside, the valve will probably leak water while no power is supplied. It is possible to open and clean the valves as described below.

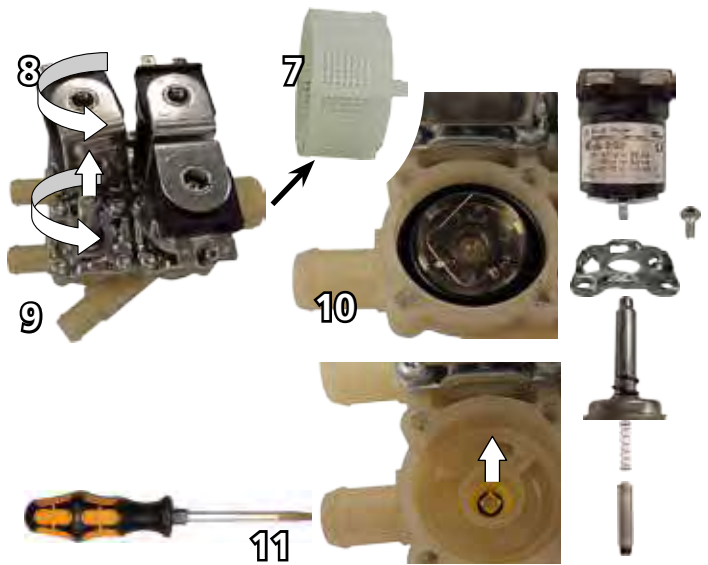

7. Check and/or clean the inlet filter.
8. Push down and turn the opposite coil $\pm 5^\circ$ ccw.
9. Push down the coil, turn $\pm 8^\circ$ ccw and pull it from the plunger housing.
10. Carefully take out the membrane.
11. Put a slotted screwdriver in the corresponding water outlet and push up the yellow reducer with white reducer holder. take them out.
12. Clean all parts.

Membrane for use without reducer



outlet direction ←

Reverse the procedure to assemble but pay attention to the following.

- The direction of the reducer holder. The arrow points to the outlet pipe direction.
- The membranes which have a reducer underneath, are less high. See pictures.

CLEANING OR RENEWAL OF WATER SPRAYERS



General information of water sprayers.

- All sprayers have 1/8" BNP pipe thread.
- The sprayers in the column and bottom pipe are all tapered (BNPt).
- The sprayers in the sidepost have parrallel thread (BNPp).
- The necessary (socket) wrench size is 11mm.

Maintenance.

- Check if the sprayer pattern of all 8 sprayers is as shown on the pictures.
- Unscrew a "defective" sprayer and clean it or put in a new one.
- At the same time check if the sprayer pipe is clean inside. Clean or replace if necessary.

Take good notice of the sprayer positions!

Sprayers in the column and bottom pipe:

These are all tapered, there is no need for teflon tape or other thread sealant on these. A little leak (drops) is no problem.

Refer to the next concerning chapter for more maintenance procedures.

Sprayers in the side post:

When unscrewing these sprayers, hold the nipple adapter [209] against loosening with a 24 mm wrench!! Refer to the next chapter.

Use teflon tape to mount these sprayers. Put them in as deep as possible but in a straight up position as shown. A little leak (drops) is no problem.

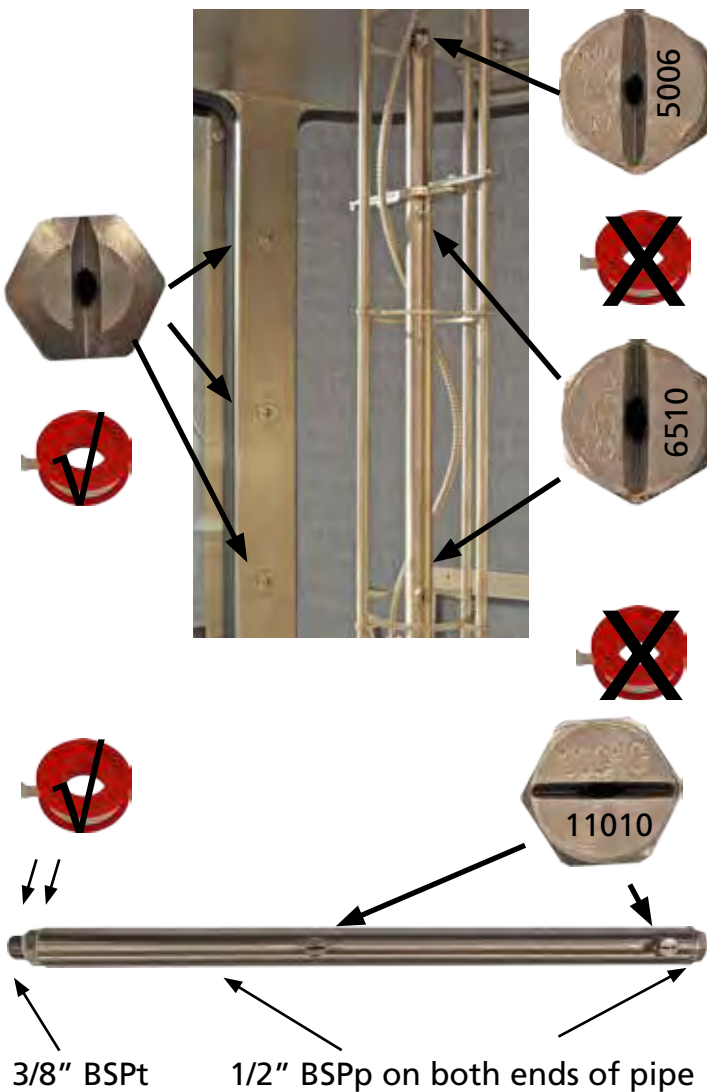

EXCHANGING THE SIDE POST PIPE AND SPRAYERS

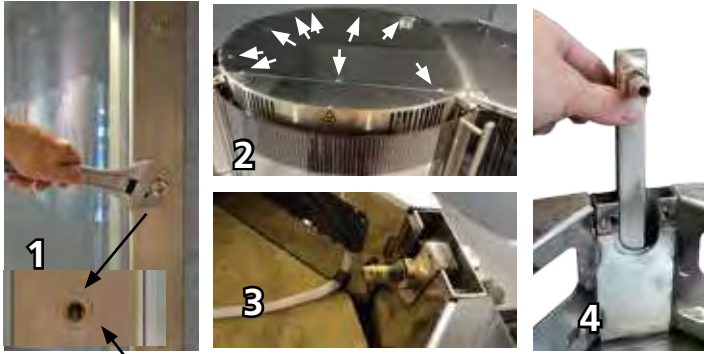

Disassembling the pipe and sprayers.

1. Remove the 3 sprayers [210] including the nipple adapters [209] from the inside. Wrench size metric 24.
2. Open the top of the unit. 9 screws
3. Loosen the hoseclamp and take off the hose. Socket size 7mm
4. Take the pipe out of the side post.
5. Clean the pipe and the thread holes in case it will be reused.
6. Also clean the holes in the sidepost.

Assembling the pipe and side post sprayers.

1. Make a mixture of the 2 component sealant. This is 1cc of resin and 8 drops of hardener for each sprayer.
2. Put the sprayer pipe from the top into the sidepost.
3. Apply a general amount of mixture on the outside thread of the nipple adapter.
4. Lift up the pipe, line up the middle hole and mount a nipple adapter in this hole, hand-tight.
5. Repeat from step 3 for the other two nipple adapters.
6. Tighten the nipple adapters with a torque of 15 lbs.ft. (20 Nm). Use a 24 mm wrench.
7. Remove the redundant sealant.
8. Mount the hose to the pipe at the top.

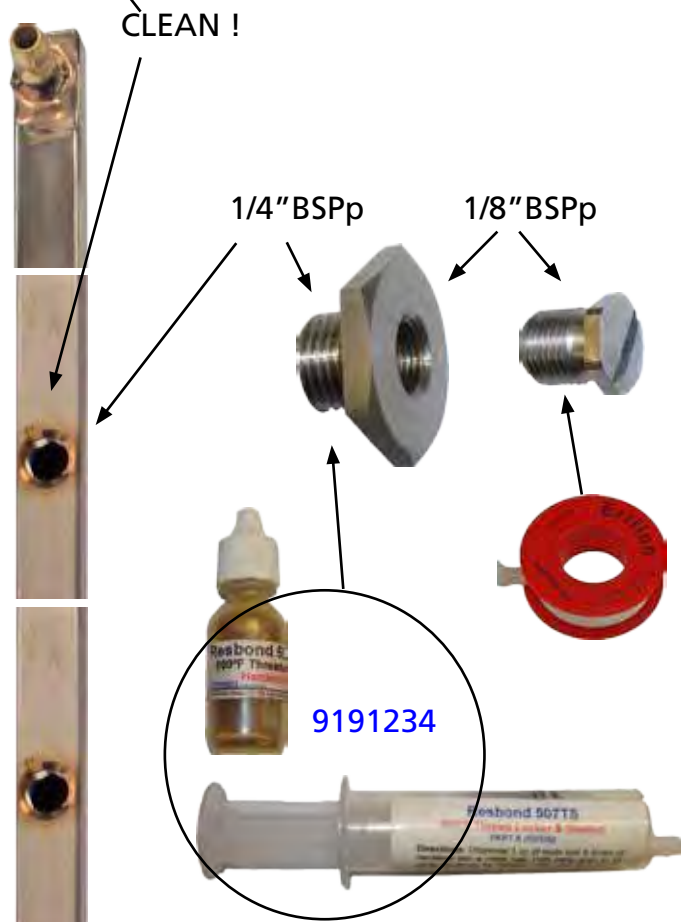

Note that units untill serial number 100046244 (July 2009) can have the old sprayers with seal ring. These must be replaced by the above mentioned nipple adapter and sprayer. Thoroughly clean the pipe thread and holes in the sidepost !!

EXCHANGING THE ROTOR COLUMN AND CENTRAL SPRAYER PIPES

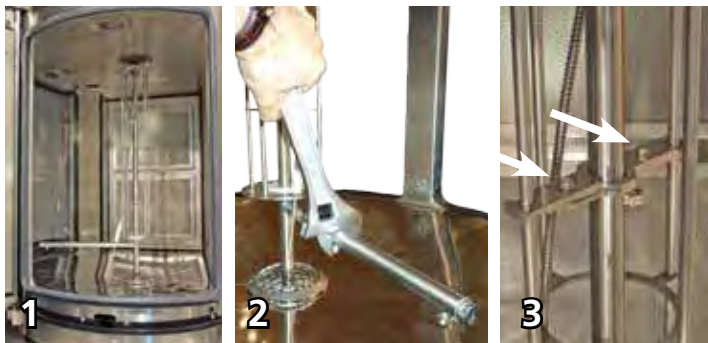

1. Remove all chicken racks and/or baskets.
2. Unscrew the horizontal sprayer pipe [224].
3. Unscrew 2 bolts M5 and remove the 2 mounting plates [215].
4. Bend the lock washer [851] open.
5. Unscrew the M22 nut [852]. Use a 32 mm wrench or suitable pliers.



Hold the column [317] with a bar (the handle of a hammer for example). Do this as high as possible.

6. Lift the central sprayer pipe [216] and take out the assembly. Be careful with the cable of the core probe!!
7. Remove the lower sprayer [212]. Slide down the pipe below the middle ring, turn it outwards and slide the pipe out of the column.

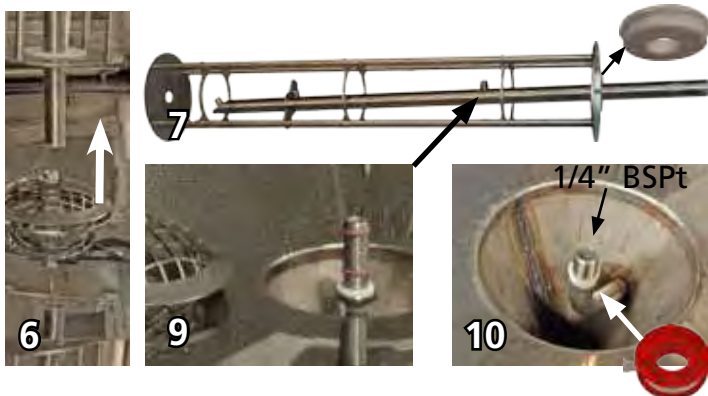

8. Remove the 2 selftapping screws and take out the teflon bearing [318]. **Only if it needs to be replaced!!**
9. Take the O-rings and the teflon washer from the joint [219].
10. Check the joint for wear. Remove it in case of wear.



Reverse the procedure to assemble but pay attention to the following:

- Take a new teflon washer and O-rings on the joint [219].
- Take a new lock washer.
- Bend the lock washer open with a screwdriver or chisel. See picture.
- Clamp the lock washer with suitable pliers
- Mount the horizontal sprayer pipe so that the sprayers point down in a $\pm 25^\circ$ forward direction as shown. Use teflon tape on the pipe thread.



EXCHANGING THE ROTOR MOTOR

Disconnect the power supply!!

1. Open the top of the unit and the service doors on the back.
2. Put a cable tie around the chain tensioner.
3. Lift the chain from the tensioner or remove the tensioner.
4. Cover the hole underneath the rotor motor to prevent bolts from falling in it.
5. Disconnect the rotor motor wires. Mark one of the white wires.
6. Unscrew the rotor motor and take the motor out. (4 bolts M6)

Reverse the procedure to install.

- Adjust the tensioner in the green area.
- Mixing up the white wires will result in a wrong rotation direction! Seen from the top, it should rotate counter clock wise.

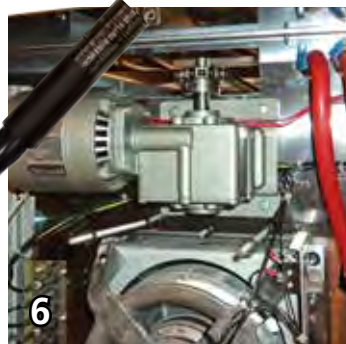
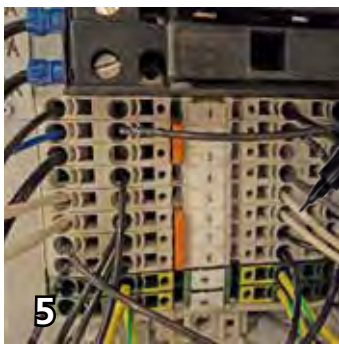
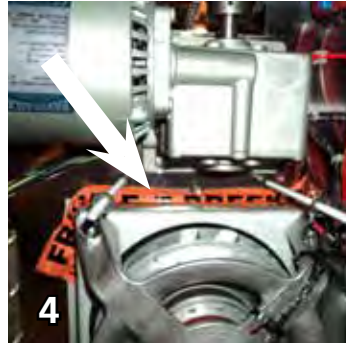
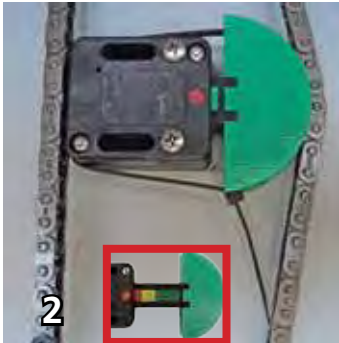
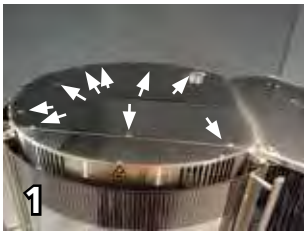

EXCHANGING THE ROTOR SHAFT

Disconnect the power supply!!

1. Unassemble the rotor column as described in a previous chapter.
2. Unscrew 3 bolts M5. (metric 8)
3. Take out the circlip [850]
4. Unassemble the rotor motor as described in the previous chapter.

Note that in case the chain is long enough, it might be possible to skip point 4, 5 and 6!

5. Check if the glass control panel and name panel cannot fall. It should be locked up behind the cover plates [559 and 563], see arrow. In case of doubt, lock them with tape or something.

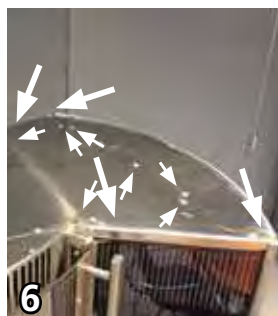
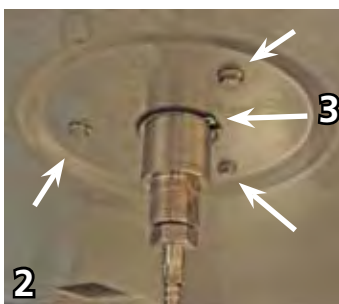

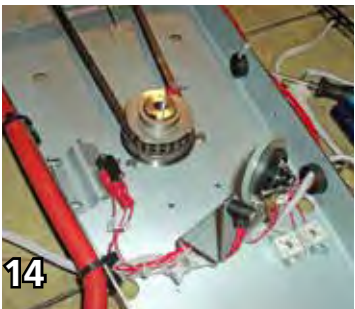
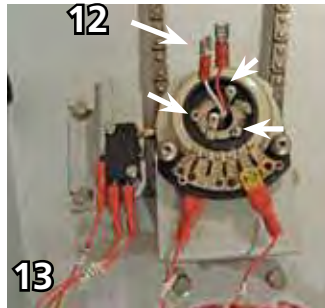
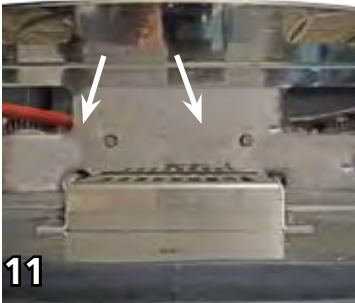
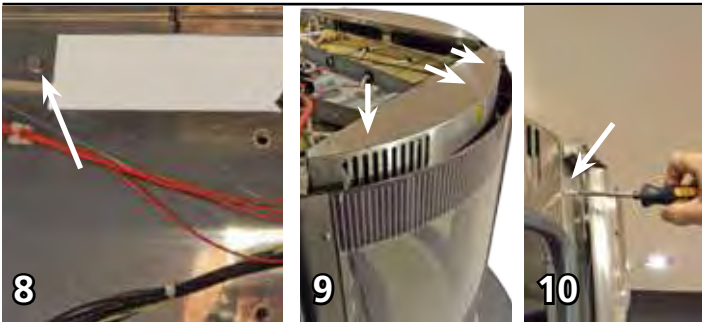

6. Unscrew 7 screws M5x12 and 4 screws M5x 30 at the top-backside.
7. Unscrew 2 bolts M5x10 at the backside and take out the top plate.
8. Loosen the screw on the back from the chain box [557] 4 turns.
9. Unscrew 3 screws at the front top.
10. Pull a screwdriver in the seam of the curved frontpanel [567] and push it out.
11. Unscrew 2 bolts from the chain box at the front side. Metric 8.
12. Disconnect the core probe wires.
13. Put some cleaning tissue in the hole of the rotor shaft and unscrew the 3 screws from the sliding ring. (M3x10).
14. Unscrew the brackets of the sliding contacts [324] and rotor position switch [323]. The sliding ring can stay in the sliding contact.
15. Remove the core sensor (from the inside), the position cam disc [301] with the several spacers and the chain from the shaft.
16. Unscrew 3 bolts. (Metric 8)
17. Lift up the chain box and lock it. Be carefull with the wiring. It might be necessary to disconnect some.
18. Lift and take out the shaft and bearing assembly [310].

Take care of clearances!!



side view detail

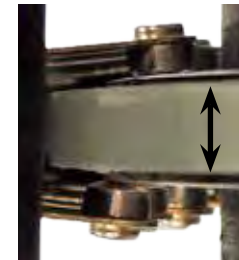

Reverse the procedure to assemble but take care of a proper adjustment of the sliding ring and contacts.
 The 3 arrows point at places where 1-2 mm clearance should be observed. It is also very important that the sliding ring is mounted in the middle of the contacts. See side view detail. Note that the contacts differ in length. On the left side, the bottom contact is longer than the top one! On the right side it is shorter!

EXCHANGING VENT PARTS

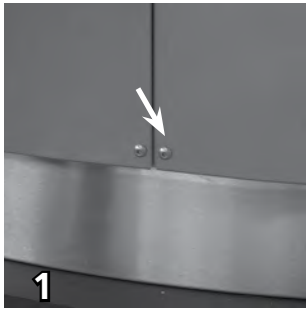

1. Open the service door on the back.
2. Unscrew 4 bolts and take out the vent motor assembly. A spring will push the shaft a little out.
3. Place a mark on the shaft at the side of the front cam.

From this point, it is possible to check the motor and the switches with help of the I/O test screen in the service menu.

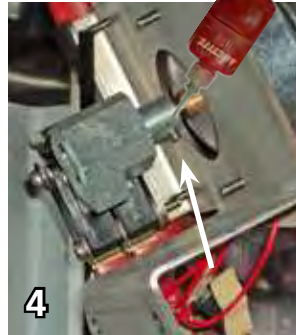

4. Check the fixation of the M3 set screw. (Metric 1,5). It is preferred to use threadlocker (loctite 620) on the motor shaft. Take care that the fluid does not penetrate between the motor bearing and shaft!

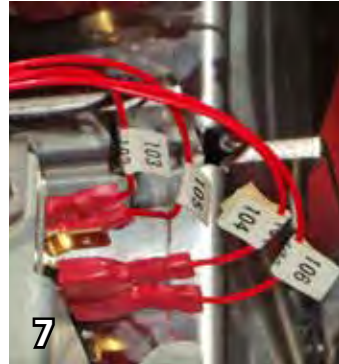

5. Check the fixation of the micro switches and the distance of the switch to the cams.
6. Loosen the the 2 screws of the switch bracket to adjust the cam distance.
7. Note the wire numbers.



8. Remove the top cover.
9. Loosen the bottom screw from the glass name plate so far that the name plate can slide outwards.

Note that this unit has the control panel on the left side!. See emergency switch.

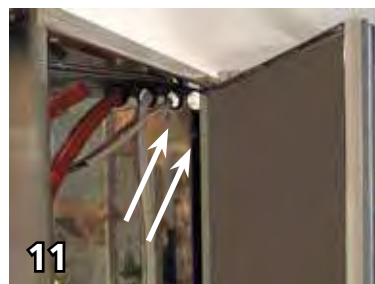

10. Unscrew the top screw and turn out the name plate.
11. Unscrew 2 bolts (metric 8) and take out the drive shaft assembly.



Note that the front cam points in the same direction as the sheet metal spring [407].

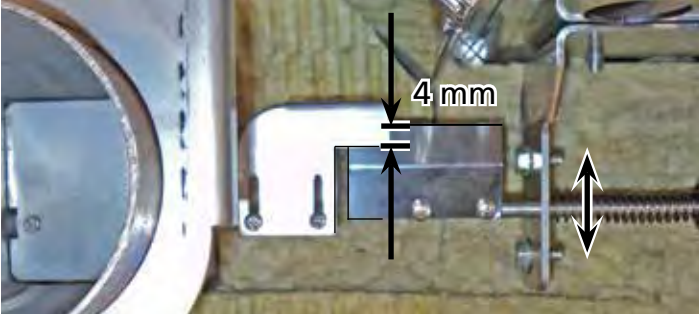

Adjustment in closed position with mounting plate [408]

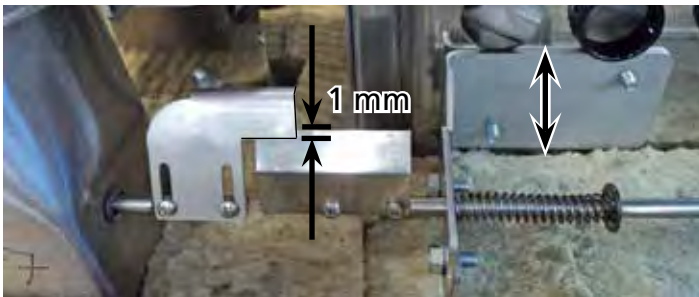

Adjustment in open position with bracket [406].

EXCHANGING THE PT1000 TEMPERATURE SENSORS

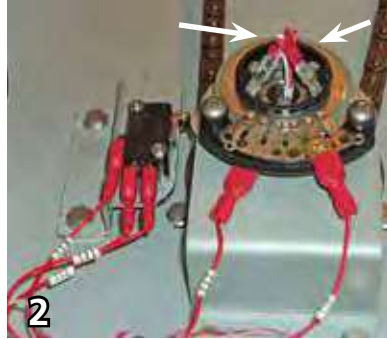

1. Open the top to gain access to the wiring.

Core probe.

2. Disconnect the 2 wires from the sliding ring.
3. Unscrew the core probe (17mm Wrench).

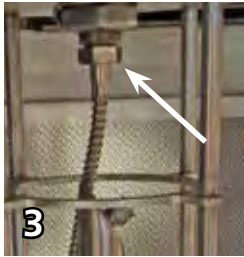

- Reverse the procedure to mount. **Do not put too much force on the 17mm bolt! it is hollow and therefore weaker !**
- Check the adjustment of the sliding ring and contacts. The 3 arrows point at places where 1-2 mm clearance should be observed. It is also very important that the sliding ring is mounted in the middle of the contacts. See side view detail. Note that the contacts differ in length. On the left side, the bottom contact is longer than the top one! On the right side it is shorter!

Take care of clearances!!

side view detail

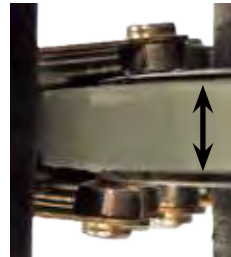

Top sensor



Top sensor.

4. Remove some insulation at the top.
 5. Unscrew the nut with a 15mm wrench and hold the sensor at the inside with a 13mm wrench.
 6. Take the sensor protection from the sensor and take out the sensor.
 7. See point 14 below for the wiring.
- Reverse the procedure to mount.

Bottom sensor



Bottom sensor.

8. Unscrew the sensor with a 13mm wrench and take off the sensor protection.
9. Cut the wire.



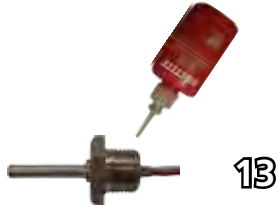

10. Tie the wires together.
 11. Pull the wire up through the side post .
 12. Twist the new sensor ± 4 turns ccw. (after mounting, the wire will have no stress)
 13. Mount the sensor with the sensor protection. Use some thread sealant.
 14. The wires can be connected with help of splices. Twist and fold the wire for the best contact. See below for official connections.
- Note that bad contacts will result in bad temperature reading, causing bad cooking results!!!!**

Each contact is a potential risk. Therefore, the best way is to lead the wires from the top and bottom sensor, all the way to the I/O board.



15. Open the service doors at the back. [551] [4 screws].
16. Disconnect the 2 capacitors [51] from the ventilator motors.
17. Take the hose with the grommet out of the transit hole.
18. Remove the vertical air suction channel. [268] (2 nuts M6 en 2x nut/bolt M5)
19. Cut the old wires loose from the wiring loom and take them out.
20. Lead the new sensor wires to the board.
20. Clamp female receptacles to the wires. (The "normal" red receptacles 6,3 and 2,8 are also possible.)

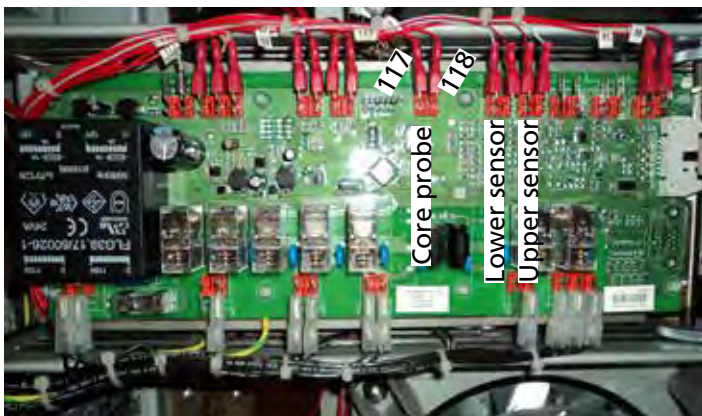

Default



EXCHANGING THE 3 WAY DRAIN VALVE

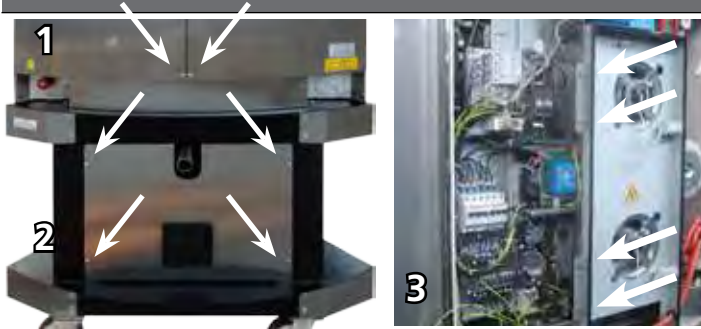

Disconnect the power supply!!

1. Open the service doors [551] on the back.
2. Open the service hatch [512] on the back of the underframe.
3. Remove the transparent safety panel [573].
4. Disconnect the power cable of the motor and pull it out of the underframe.

- The power lines (1,3, 4 and PE) are connected to the terminal block.
- The feed back lines (5 and 6) are directly connected to the relays.
- The number 2 wire has been cut out the cable!
- **Note that it is also possible to disconnect the cable on the motor itself.** In that case you can skip the steps 1 and 3.

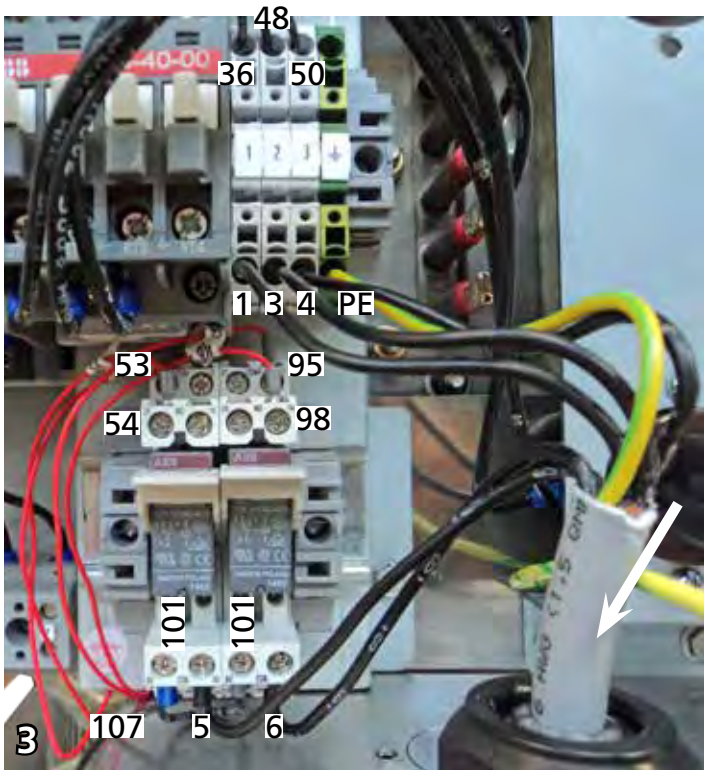

4. Open the suspension clip.
 5. Loosen the swivel of the 1" joint a few turns so that the assembly can move a little.
 6. Loosen the hose clamp and release the hose from sticking to the pipe by twisting it.
 7. Completely turn the swivel loose and take out the assembly.
- It is now possible to disassemble the assembly.

Reverse the procedure to mount the drain valve assembly.



8. The assembly can be taken apart by unscrewing the inner sliding pipe [370]. A few beats with a hammer on the lever will loosen the pipe.
9. The motor can easily be taken from the valve by unscrewing 4 bolts. Use a 10mm wrench.
 - Note that this can also be done while the valve is still mounted under the unit.
 - Do not loose the 2 (square) filler bushes!
 - Mark the position of the shaft and also take good notice of the position of the valve (operation or drain).
 - The ball valve can be operated manual now with a wrench (11mm).

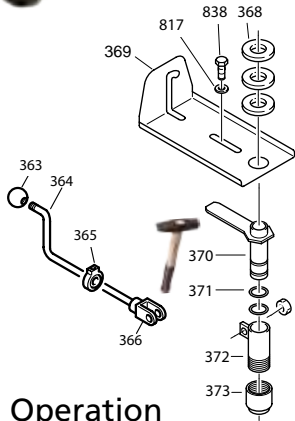

Operation

Drain

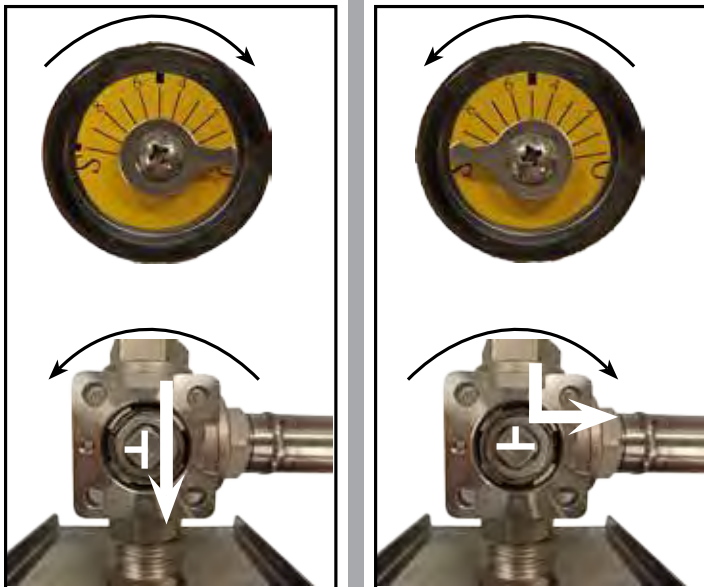

The figures show the two positions and how they can be recognized.

With help of the I/O test screen in the service menu, it is possible to check the functions of the valve.

With help of a self made test rig, it is possible to check the functions manually. Take care of the necessary safety precautions!!

Power (208 V) between wire 1 and 3 will put the valve in operation position. The indication arrow will turn clockwise (cw) while the valve will turn ccw.

In this position, there will be 208V between wire 1 and 5. (feedback signal)

Power between wire 1 and 4 will put the valve in drain position. The indication arrow will turn counter clockwise (ccw) while the valve will turn cw.

In this position, there will be 208V between wire 1 and 6. (feedback signal)

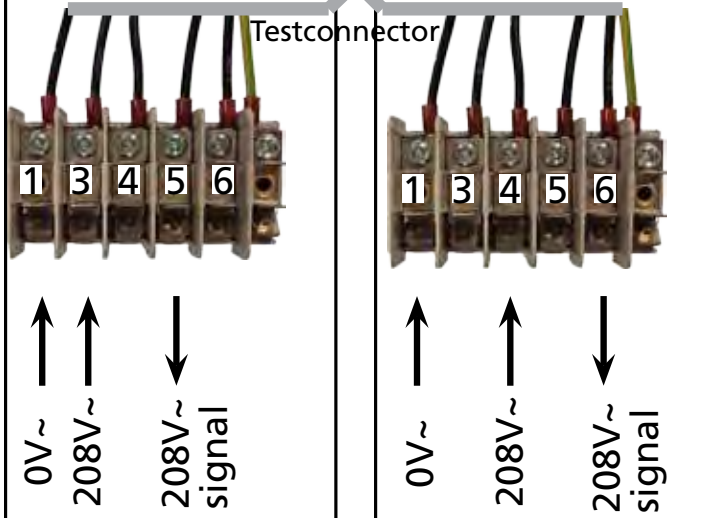

EXCHANGING THE EMERGENCY SWITCH



Disconnect the power supply!!

1. Open the service doors on the back. (4 screws)
2. Remove the curved panel [274]. (2 screws)

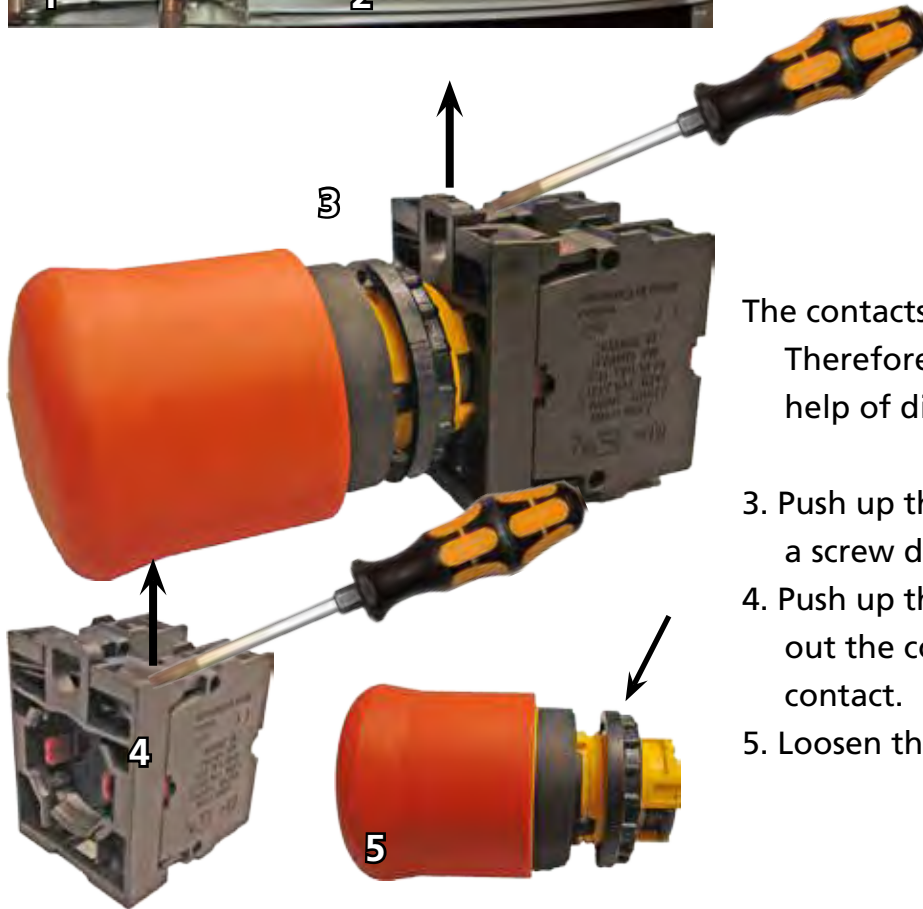

The contacts of the switch are out of sight. Therefore the rest of the description is with help of dismantled parts.

3. Push up the lever in the middle with help of a screw driver and take out the contacts.
4. Push up the lever of the contact and take out the contact. Repeat this for the other contact.
5. Loosen the nut and take out the knob.

Overview



EXCHANGING THE DOORSWITCHES

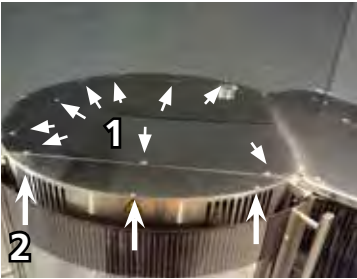

1. Open the top of the unit.
2. Unscrew 3 screws at the top.
3. Pull a screwdriver in the seam of the curved frontpanel [567] and push it out.
4. Loosen the set screw [871] a few turns and pull out the reed switch.
5. Disconnect the reedswitch from the ceramic terminal block [69].



- Reverse the procedure to mount the switch.
- Adjust the switch as shown on the picture!
 - Do not put too much force on the screw!
The switch is inside the hollow brass pipe.

History.

- A. Untill serial number 100047331 (April 2009), the reed switch has been placed at the hinge side. The switch is placed "parallel" to the magnet.
- B. Untill serial number 100051088 the reed switch has been placed at the handle side, also "parallel" to the magnet.
- C. Untill serial number 100051252, the reed switch has been placed at the handle side "in series" with the magnet with help of a 90° bush.
- D. From 100051253, the reed switch has been mounted as shown on picture 4 and 6 with a welded bush.

Reed switch at hinge side (untill 100047331)

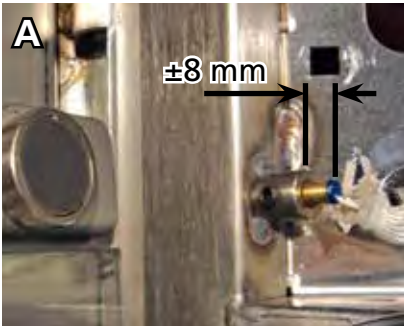

Mounting position
Parallel to magnet



Reed switch at handle side (from 100047332)

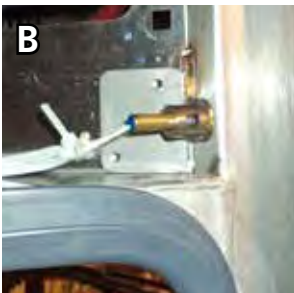

Mounting position
Parallel to magnet



Improved with
90° bush!



In case of doubt of good functioning, in situation "B", it is advised to update to situation "C" with help of the 90° bush.

Necessary parts (3x)

9192347 - 90° bush

9191049 - Set screw M5x5

EXCHANGING THE DOORS AND DOOR PARTS

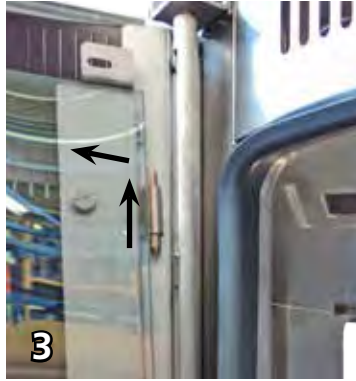

1. Open the door.
2. Open the inner door by pulling it from the outer door at the top.
3. Lift the inner door ± 1 inch and pull it out of the outer door. **The weight is 8,5kg**
4. Put the inner door on a safe place. Put some carton under it when placing it on the floor. Make sure that it cannot slide away and fall!!



5. Loosen the top hinge bolt with a 17mm wrench.
6. Take the outer door with the left hand at the hinge side, lift a little to release the bolt and pull out the hinge bolt.
7. Take the door with the right hand at the bottom side, lower the left hand a little and lift the door from the lower hinge. **The weight is 15kg!**
8. Put the outer door on a safe place. Put some carton under it when placing it on the floor. Make sure that it cannot slide away and fall!!

Adjusting the outer door.

Step 1

Step 2

Step 3
Check
clearance

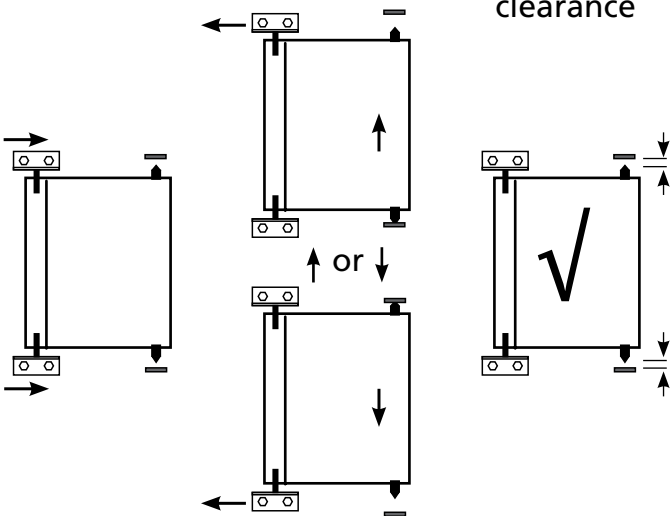

Note that it is possible to take out the complete assembly of outer and inner door in one time. **This is of course much heavier. Total weight is 23,5kg!** Therefore it is advised to do that with 2 persons. In this case it is possible to skip #2, 3 and 4.

Reverse the procedure to hang in the doors.

Adjusting the outer doors.

Step 1.

- Loosen the bolts of the top hinge of the left door, slide the hinge to the right as far as possible and fasten the bolts again.
- Do the same with the bottom hinge.



Overview of hinges and catches.

Left door middle door right door



Note that a washer is used under the top hinge bolt, in case a door "stop" is mounted

Step 2.

- Fully open the doorhandle and check the clearance between the Locking pin and the catch at the top and the bottom side. This should be \pm the same.
- Move the corresponding hinge to achieve this.

Step 3. In case this is ok then repeat this for the middle door and the right door.

In case it is not possible to get clearance at the bottom pin, then check the doorhandle mechanism. There is probably some wear, causing too much slack. Check this by pushing up the lower pin. 1 mm is normal.

Adjusting the inner door.

Preface.

The inner door must "grap" with the magnet holder [118] behind the finishing plate [153] of the outer door.

In this way, the inner door will be "pulled" around the doorgasket when the outer door is being closed.

1. Check the distance between the glass and the hinge profile. This must be $< 1/32"$ ($< 1\text{mm}$)
2. Check if the 2 bolts on the hinge side are tightened.
3. Repeat #1 and 2 for the bolts of the magnet holder .

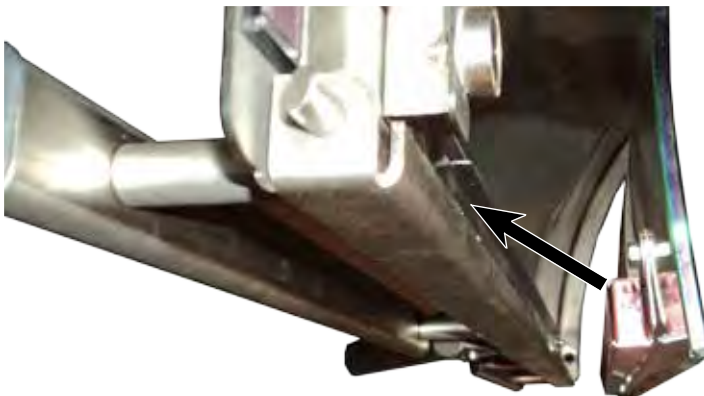

Mounting of glass

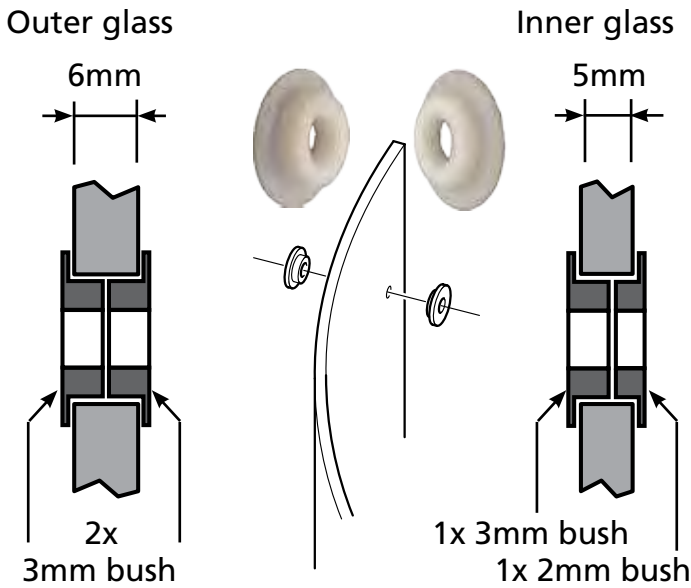

Mounting of the glass.

- The glass must never touch the metal! Therefore, a ptfе collar bush is applied at each bolt. 2 different sizes are available, 2mm [109] and 3mm [110]. See drawing how to use.
- Refer to the exploded views to see how each door is assembled.
- The torque for all bolts, going through these bushes is 8Nm (6lbf-ft).

Exchanging doorhandle parts.

1. Remove 2 nuts (metric 8). Hold the screw with a "philips". *Note that threadlocker has been applied. An impact driver might be useful.*
2. Take out the finishing plate [153]. *Note that the handle profile [147] on the other side is glued to the glass and will not fall.*
3. Unscrew 4 screws, slide out both latch rods and take out both drive plates.
4. Loosen the screw from the fixed doorhandle above the lock construction profile [131].
5. Unscrew 2 screws on the side of the handle.
6. Push out the bushes [815] and take out the handle [130].
7. Turn the upper door handle away, unscrew 2 screws and take out the doorhandle assembly [104]
8. Push out the pin [136] and take out the top and bottom lever [138 and 139].

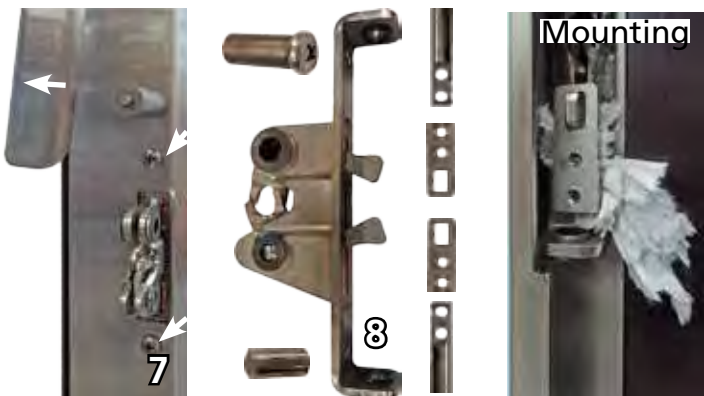
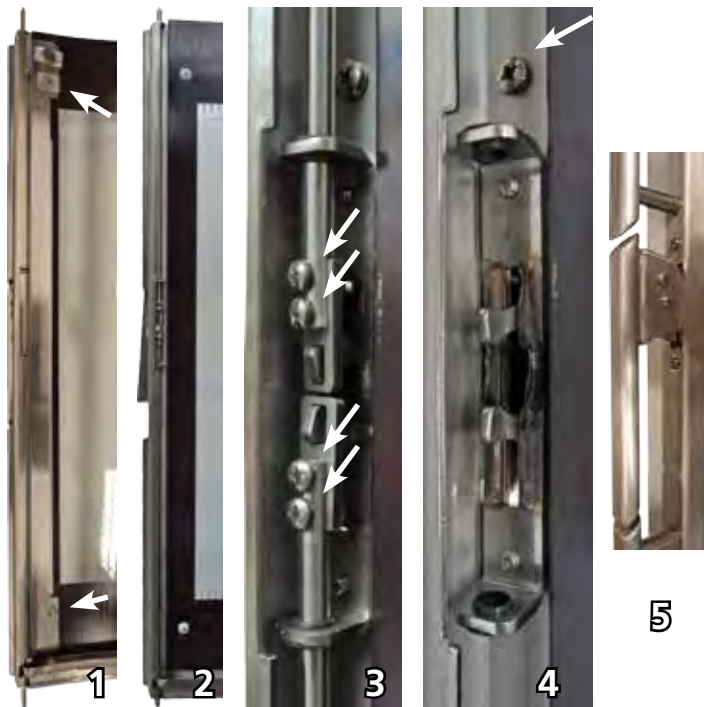

Reverse the procedure to assemble.

Check / tighten the screws of the fixed doorhandles.

Put some tissue behind the drive plate to ease the mounting and then slide the latch rod in front of it.

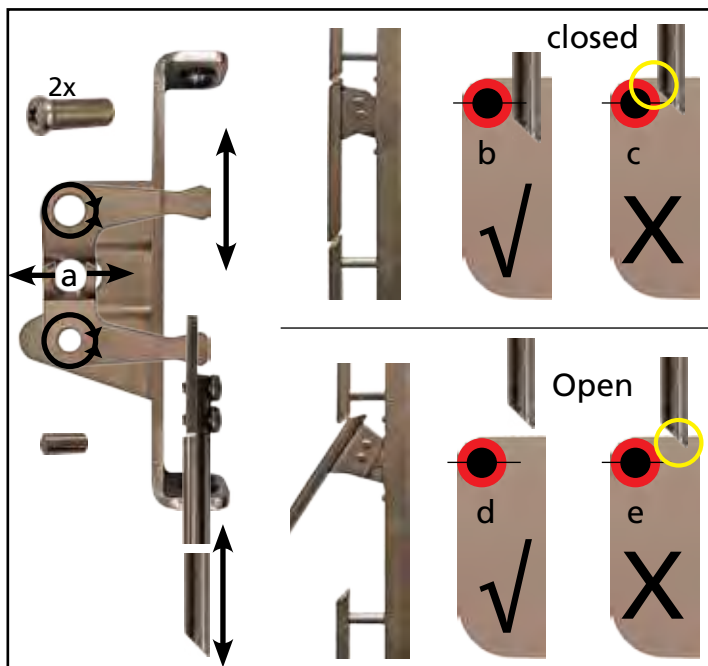

Additional information.

Too much play between the threaded bush and both levers (see a), will cause malfunction of the doorlock. In most occasions when closing the door, the bottom latch rod touches the catch (e) and it is not pushed down far enough (c). After some while, during cooking the door will automatically open.

Exchanging the levers [138 and 139] and bushes [815].

1. Close the door and make sure that both (top and bottom) latch rods are fully behind the roll of the catch, as shown on picture b.
2. Unscrew 2 screws on the side of the handle, push out the bushes [815] and take out the handle [130].
3. Push out the pin [136] and take out both levers [138 and 139].
4. Take a new bottom lever [139], position it in the drive plate of the lower latch rod[150] and mount it with the pin [136].
5. Position a new top lever in the drive plate of the upper latch rod[148] and let it rest on the lower lever.
6. Position the handle and put the bush in as far as possible.
7. Line up the upper lever and put the bush through the hole.
8. Do the same with the other bush and mount the screws.

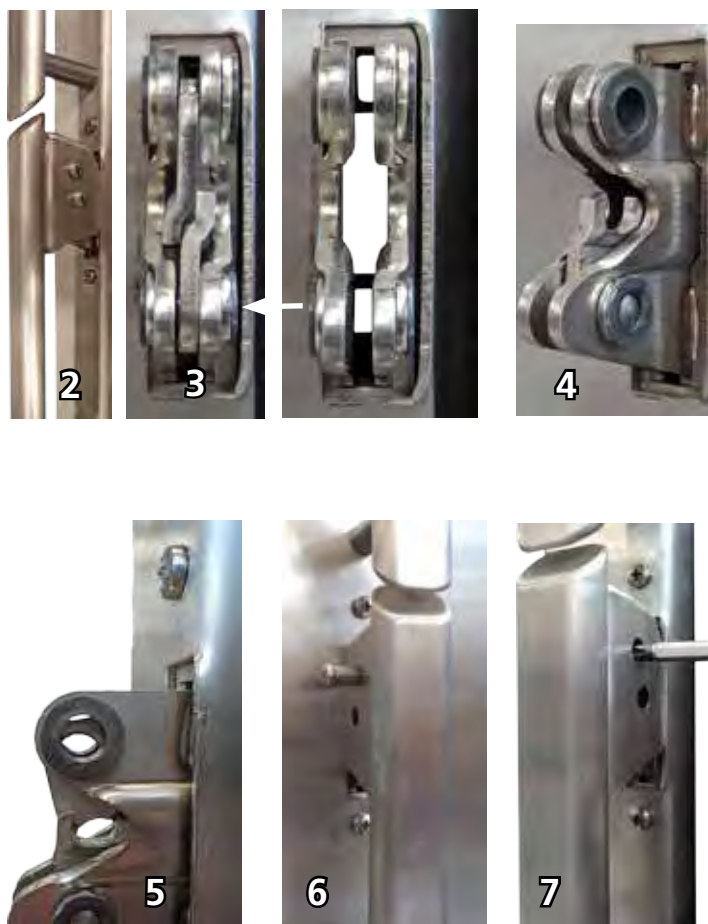

EXCHANGING SOAP INJECTION PARTS

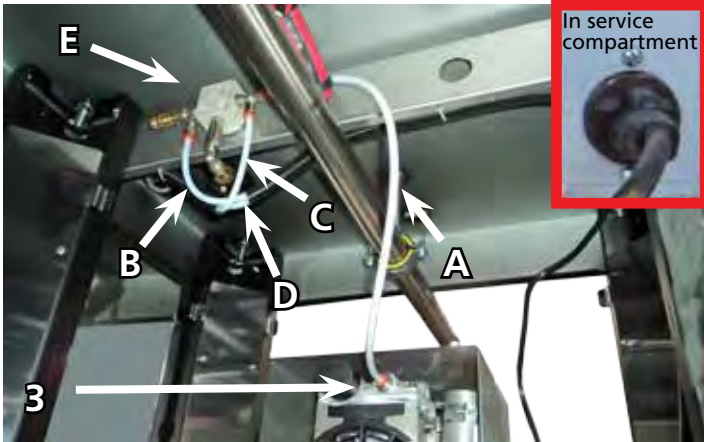

Disconnect the power supply!!

Compressor.

1. Open the service doors on the back and the hatch of the underframe.
2. Pull the plug of the compressor from the socket in the service compartment.
3. Push in the ring of the adapter [468] and pull out the hose from the compressor.
4. Unscrew the bracket [471] from the floor and take the compressor out of the underframe.
5. Remove the cover [472].
6. Unscrew the compressor from the bracket. 4 nuts 1/4" [868].

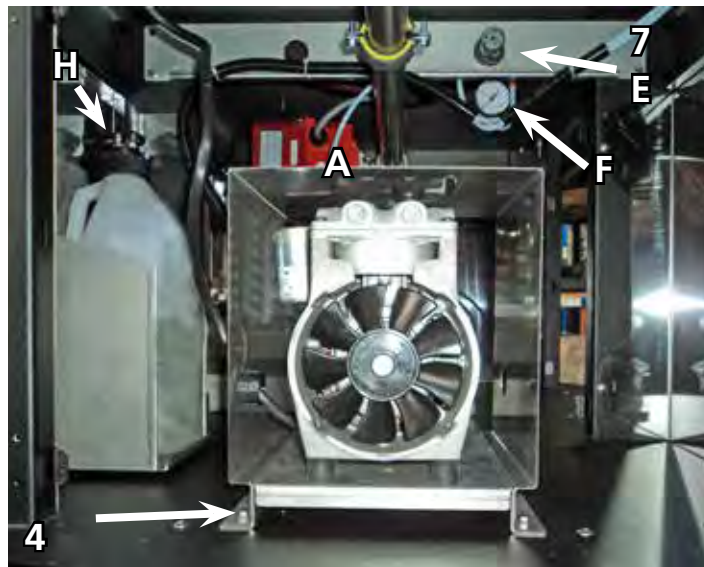
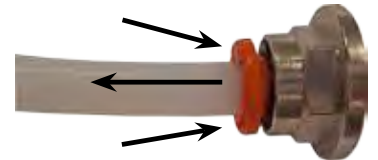

Reverse the procedure to assemble.

Reducer.

7. Unscrew the plastic nut and take the reducer from the bracket.
8. Disconnect the hoses as described at #3.

Reverse the procedure to assemble.

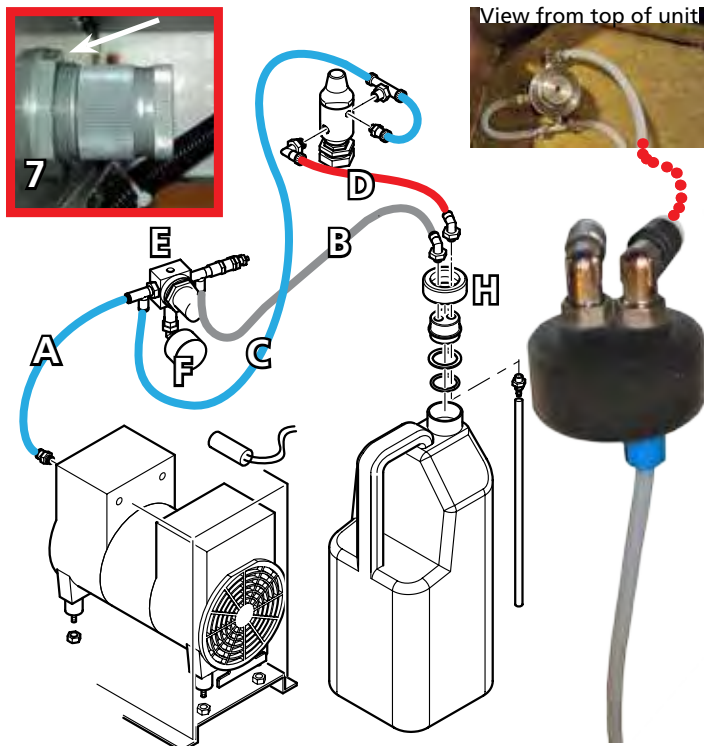

Description of labels:

- A. Air (high)pressure hose from compressor.
- B. Low pressure from reducer to soap bottle.
- C. Air (high)pressure hose going to soap mister.
- D. Soap hose going to soap mister.
- E. Pressure reducer adjusted at 250 - 300mBar.
- F. Pressure gauge.
- H. Bottle cap with swivel. Note that the soap outlet is marked black.
- I. Soap mister. (pressure controlled nozzle)



Soap mister (pressure controlled soap nozzle).

9. Unscrew the nut from the inside. Wrench size 32mm.
10. Disconnect the hoses from the mister and take it out.

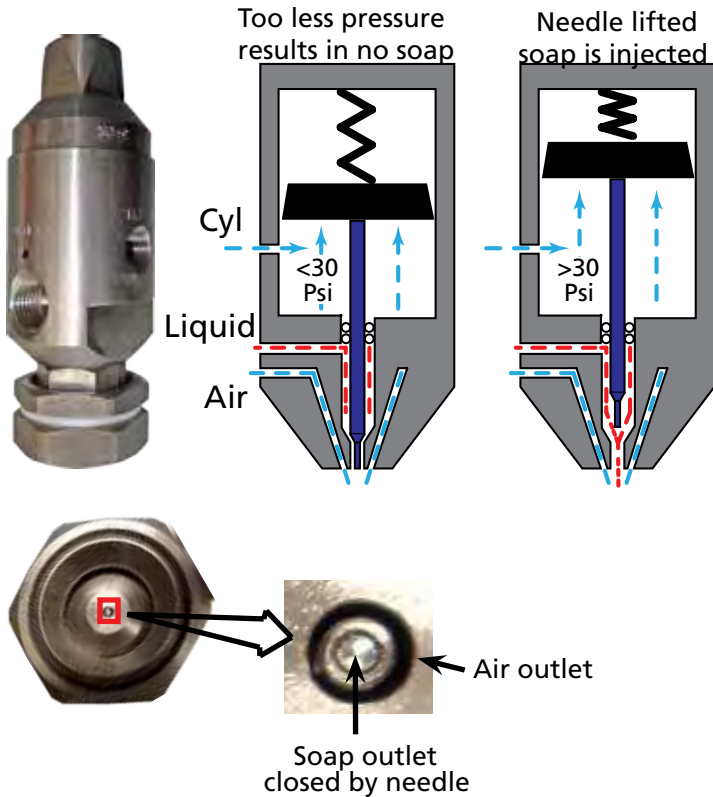

Additional information.

As soon as the compressor starts, air will go through hose A and C and flushes out the ring shaped opening in the mister around the actual soap nozzle.

At the same time, pressure (250-300mBar) from the reducer comes on the bottle through hose "B" and soap is pushed up to the mister through hose "D".

When the air pressure exceeds 30psi (2,1Bar), the needle [451] will be lifted and soap can come through the center opening.

See operating principle.

Causes of no or less soap injection:

The compressor has a limited yield. This means that when an air leak occurs somewhere, the pressure will drop and the needle will not lift (enough).

In case the bottle cap is not well mounted on the bottle, air will leak and pressure drops.

In case the O-rings [452] around the needle are deteriorated, the needle will not lift (enough). -->Repair with service set.

In case the 2 hoses on the bottle cap are interchanged, no soap will be pushed up. The air comes in the bottle through the hose and pressed foam will be created. When the compressor stops, the pressed foam will find its way through the reducer back to the compressor!!! -->Connect the hoses in the right way and let the unit run a few rinse cycles with water.

Exploded view of soap mister

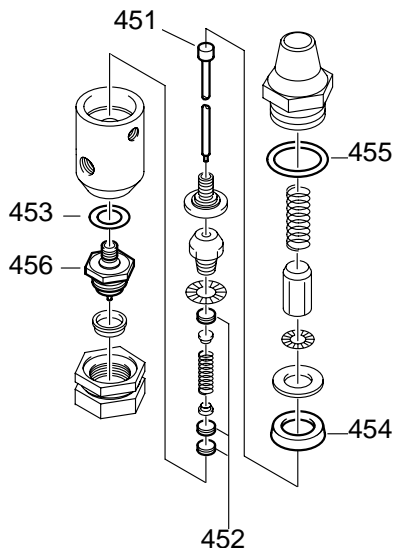

MEASURING ON THE BLOWER CIRCUIT (FROM MAY 2014)

Working principle.

A transformer is used to be able to switch the 2 blowers on low speed (175Volt) or high speed (208Volt).

Since May 2014, the transformer gets power as soon as the key switch is switched ON.

The 2 NTC resistors (NTC 5.0) limit the inrush current.

In case these NTC resistors are not present on the blowers terminal block (between terminal 2 / 3 and 3 / 4), it is advised to upgrade the wiring with the speed transformer kit 9190193s.

Fault finding will be much easier! See chapter service instructions.

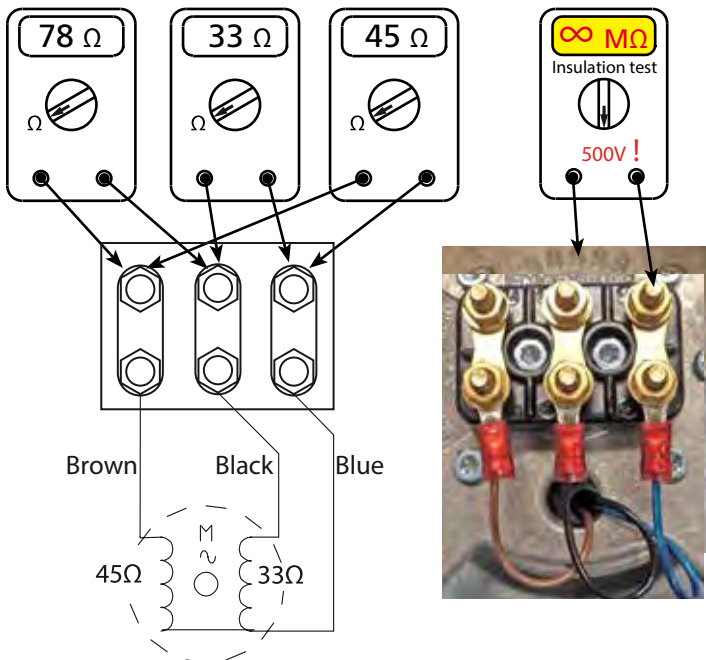
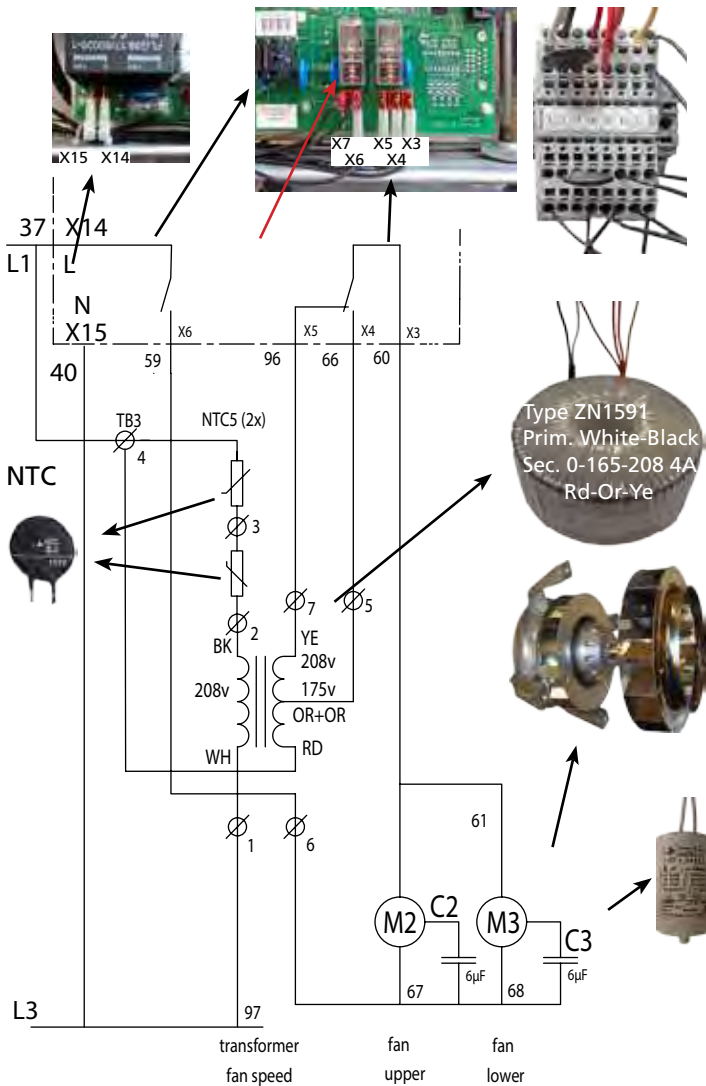

Passive measurements (resistance and capacitance)

Disconnect the mains supply first!

The Blowers.

- The overview shows how the coils are connected to the terminal block on the back of the blowers.
- It also shows the connections between the terminals on the terminal block itself.

Measuring the blower coils.

Disconnect the feedwires on the screw terminals first!

Main coil:	33 Ω.	Between Black and Blue
Start coil:	45 Ω.	Between Brown and Blue
Both coils:	78 Ω.	Between Black and Brown

Insulation test: ∞ MΩ between a terminal and ground.

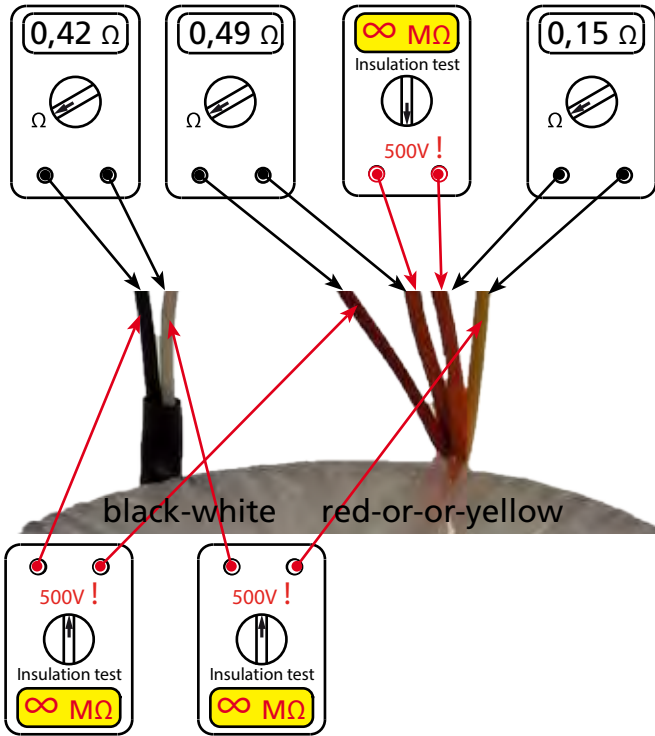

The speed transformer.

General.

This transformer has big copper wires and therefore the resistance is very low. For this reason it is difficult to measure the right value because of deviations in the multimeter and contact resistances of the test probes.

Therefore it is recommended to define this measurement error as good as possible with the following instruction.

Prevention of measurement errors!

- Put both test probes on the same terminal or in this case the same wire.
- Write down the reading. For example 0,22 Ω.
- Subtract this value from the next measurements. For example, the reading of the primary coil is 0,64 Ω. The real value is 0,64 - 0,22 = 0,42 Ω.

Tip: Insulation testers (Megger) often have a very good resistance meter.

Measuring the transformer coils. (see overview)

Disconnect the wires from the terminal block first.

The transformer has 3 separated coils. 1 Primary coil and 2 secondary coils.

Resistance:

- Primary coil (black - white): 0,42 Ω
- Secondary coil (Yellow-Or): 0,15 Ω
- Secondary coil (Or - Red): 0,49 Ω

Insulation:

- Prim.-sec.1 (Black-Red): ∞ Ω
- Prim.-sec.2 (White- Yellow) ∞ Ω
- Sec.1-sec.2 (Orange-Orange) ∞ Ω

The 6µF capacitors

General

Even with a capacitance meter it is impossible to determine for sure if the capacitor is ok or not, because it can be leaking when it is connected to mains power. A quick optical check often tells more. Search for leaking oil and / or bulges (lumps).

Measuring with an insulation tester in 500V position. Work under safe conditions according local legislation!

The value will not reach ∞ Ω, but will go up and down a little. When it is above 50MΩ it will be ok. Disconnect the test leads while the value is at the highest position. The capacitor is now charged with ± 500VDC!! Leave it for a few seconds and then put the wires together. A loud spark must arise. If not, the capacitor is leaking (losing its charge). It is also possible to charge the capacitor by shortly con-

Define the measurement error.



Electrical diagram speed transformer

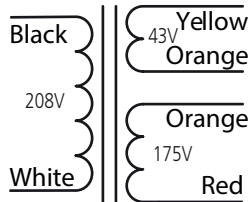

Loosening wires: Push a small slotted screwdriver (max 5/32") in the square hole, turn it (or "bend" it) and take out the wire.

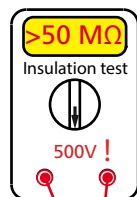
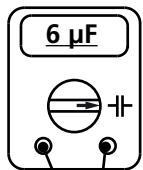
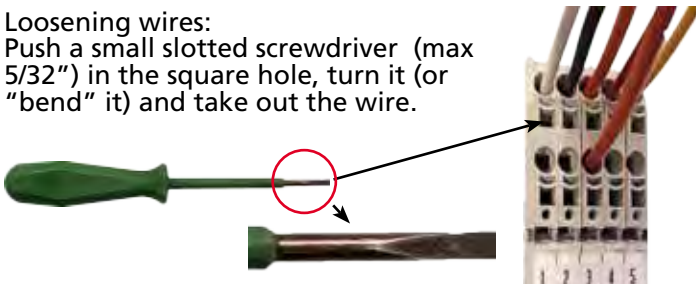

Charging with a test cable

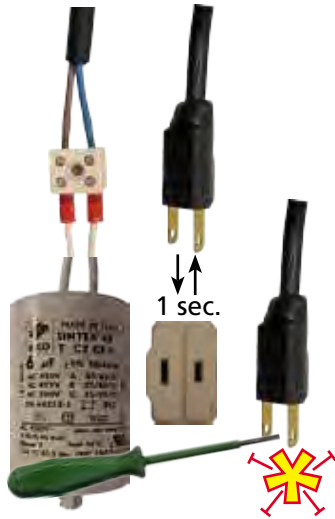

Checking with an Ω meter

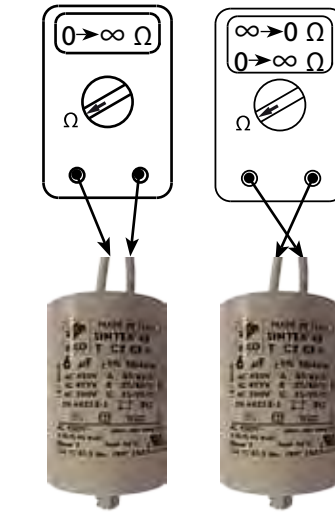

necting it to the mains supply (208V~). The same spark must arise. Do this a few times. The capacitor will not be charged when the leads are disconnected during the “zero crossing” of the mains sinus. It is ok when a spark arises once.

Measuring with an Ω meter.

Be sure that the capacitor is empty!

The value will go up until ∞ Ω is reached. Exchange the test leads. The value will go down, through “0” and up again.

If not, the capacitor is broken.

If ok, it is still not sure if the capacitor is ok. It might leak when it is connected to the mains power!

Active measurements.

You are about to measure on a 3 phase 208V~ circuit!! You need to be qualified for this! Always work according local legislations!

For measuring on the transformer terminal block:

- Use short test probes or-
 - Unscrew the terminal block and turn it outwards or-
 - Turn out the glass panel.
- Switch on the unit .

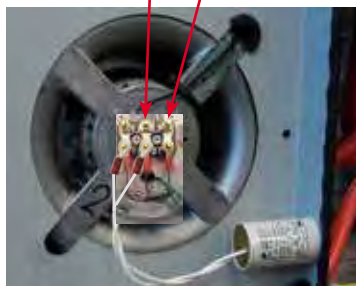
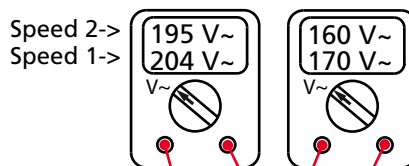
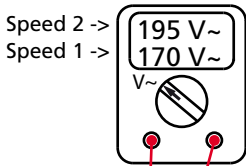

Voltagess that can be expected in normal situation.

All voltagess are related to a line voltage of 208V~

Blowers in high speed (speed 2 in cooking program):

- On the screw terminals of the blowers: 195V~
- On the terminal block
- Between Red (4) and Yellow (5): 195V~
- Between Red (4) and Orange (3): 160V~.

Blowers in low speed (speed 1 in cooking program):

- On the screw terminals of the blowers: 170V~
- On the terminal block
- Between Red (4) and Yellow (5): 204V~
- Between Red (4) and Orange (3): 170V~.

Trouble shooting with help of the I/O test facility .

- Open the settings menu
- Choose service and give in the pin code 4878
- Select “I/O test” and choose MFMB outputs.

2 keys are available to test the blower outputs. The “X” numbers relate to the corresponding outputs on the circuit boards.

X3 is the relay that switches high and low speed. “1” is low speed. (mentioned wrong on the screen!)

X6 Switches full power on the transformer.

First choose the speed on X3 and then switch on the blower with X6

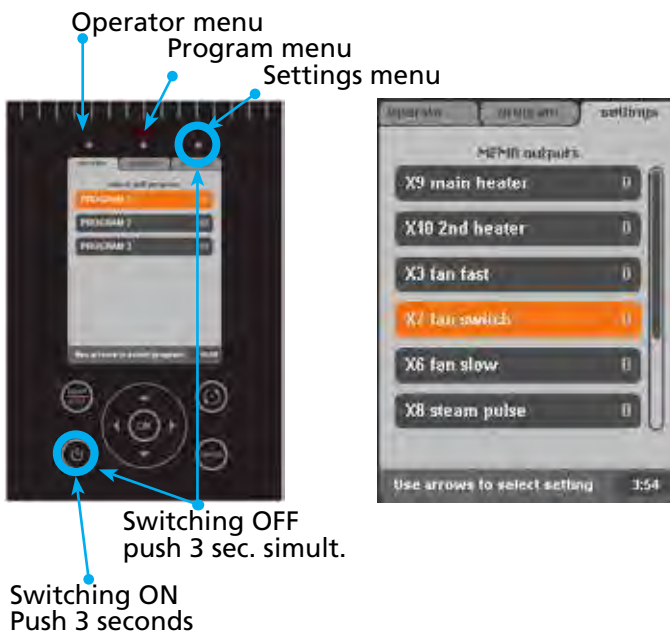

MEASURING ON THE BLOWER CIRCUIT (UNTILL MAY 2014, UNLESS UPDATED)

It is advised to upgrade this wiring with the speed transformer kit 9190193s.

Working principle.

A transformer is used to be able to switch the 2 blowers on low speed (165Volt) or high speed (208Volt). Since the transformer has a large inrush current, a slow start was necessary. This is accomplished with the 22 Ω resistor and the Solid state relay on output X7.

Blowers "Power ON" sequence

When the transformer is switched on, the SSR on X7 puts power on the transformer, through the resistor during 0,5 seconds. During this time, 50 Volt can be measured over the resistor (with a suitable meter). After that, X6 is switched on and now the full power is put on the transformer.

Blowers "low speed" sequence.

In case the blowers are set on low speed in the cooking program, the blowers will start up in high speed as explained above. After 10 seconds, X6 opens, X4 closes (X5 opens) followed by the power ON sequence.

Passive measurements (resistance and capacitance)

Disconnect the mains supply first!

The Blowers.

- The overview shows how the coils are connected to the terminal block on the back of the blowers.
- It also shows the connections between the terminals on the terminal block itself.

Measuring the blower coils.

Disconnect the feedwires on the screw terminals first!

- Main coil: 33 Ω. Between Black and Blue
- Start coil: 45 Ω. Between Brown and Blue
- Both coils: 78 Ω. Between Black and Brown
- Insulation test: ∞ MΩ between a terminal and ground.

0,62 Ω can be expected when measuring on the screw terminals (black and blue) in case they are not disconnected. This is because of the transformer coils.

The Resistor.

It does not need to be disconnected. The resistance is 22 Ω.

In case the resistance is higher, then the resistor is broken.

In case the resistance is lower, then disconnect and measure again.

In case it is still lower, then the resistor is broken.

In case it is ok, then the I/O board is broken.

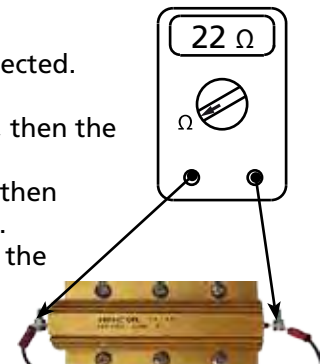
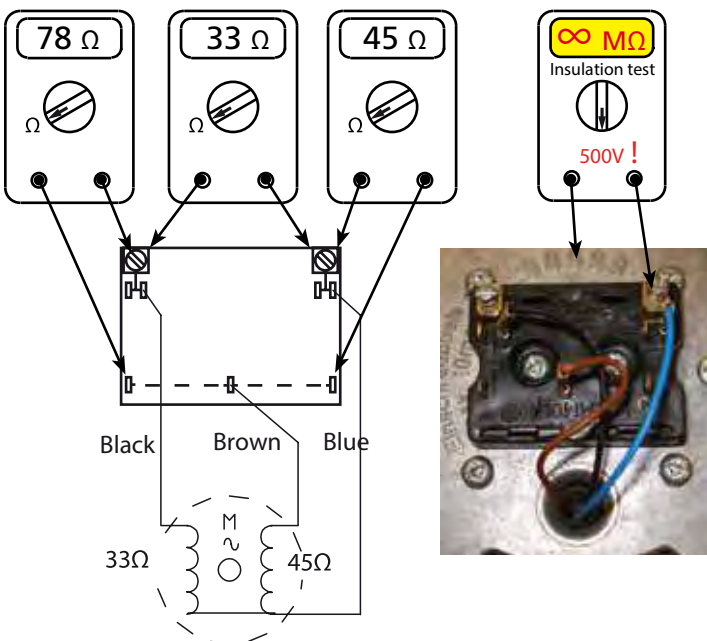
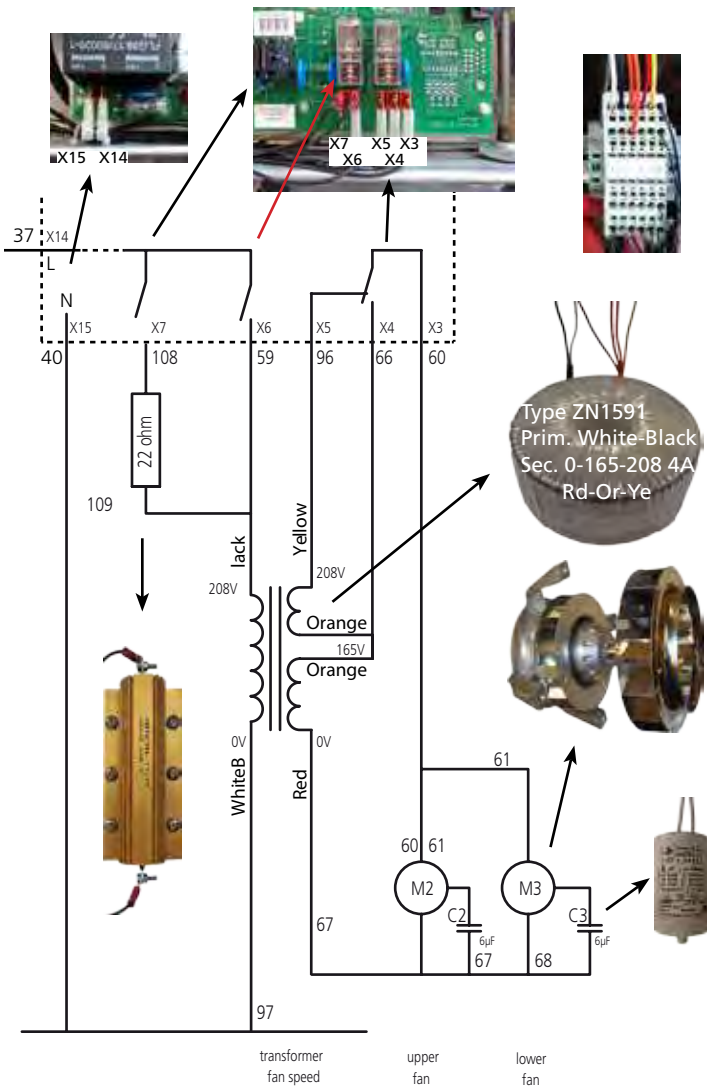

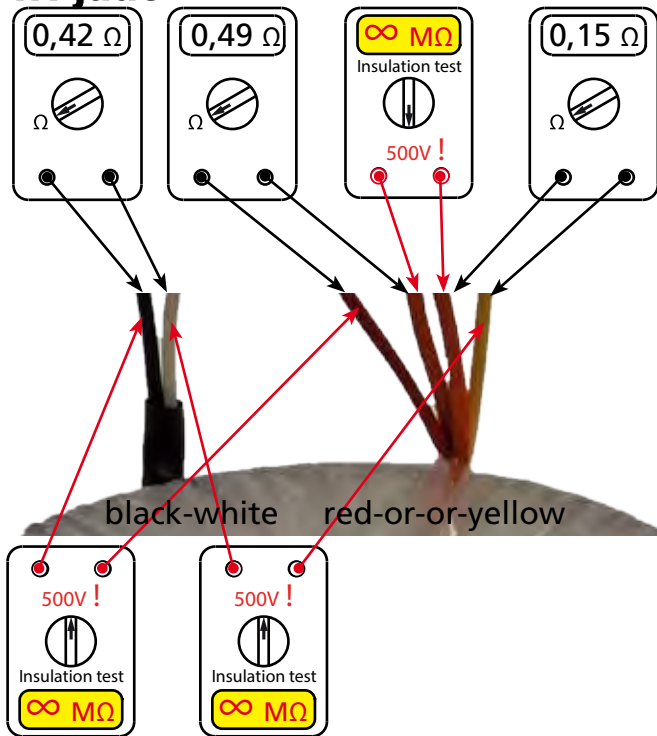

The speed transformer.

General.

This transformer has big copper wires and therefore the resistance is very low. For this reason it is difficult to measure the right value because of deviations in the multimeter and contact resistances of the test probes.

Therefore it is recommended to define this measurement error as good as possible with the following instruction.

Prevention of measurement errors!

- Put both test probes on the same terminal or in this case the same wire.
- Write down the reading. For example 0,22 Ω.
- Subtract this value from the next measurements. For example, the reading of the primary coil is 0,64 Ω. The real value is 0,64 - 0,22 = 0,42 Ω.

Tip: Insulation testers (Megger) often have a very good resistance meter.

Measuring the transformer coils. (see overview)

Disconnect the wires from the terminal block first.

The transformer has 3 separated coils. 1 Primary coil and 2 secondary coils.

Resistance:

- Primary coil (black - white): 0,42 Ω
- Secondary coil (Yellow-Or): 0,15 Ω
- Secondary coil (Or - Red): 0,49 Ω

Insulation:

- Prim.-sec.1 (Black-Red): ∞ Ω
- Prim.-sec.2 (White- Yellow) ∞ Ω
- Sec.1-sec.2 (Orange-Orange) ∞ Ω

The 6µF capacitors

General

Even with a capacitance meter it is impossible to determine for sure if the capacitor is ok or not, because it can be leaking when it is connected to mains power. A quick optical check often tells more. Search for leaking oil and / or bulges (lumps).

Measuring with an insulation tester in 500V position. Work under safe conditions according local legislation!

The value will not reach ∞ Ω, but will go up and down a little. When it is above 50MΩ it will be ok. Disconnect the test leads while the value is at the highest position. The capacitor is now charged with ± 500VDC!! Leave it for a few seconds and then put the wires together. A loud spark must arise. If not, the capacitor is leaking (losing its charge). It is also possible to charge the capacitor by shortly con

Define the measurement error.



Electrical diagram speed transformer

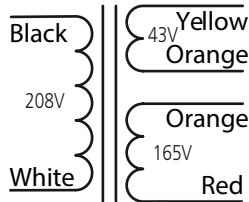

Loosening wires: Push a small slotted screwdriver (max 5/32") in the square hole, turn it (or "bend" it) and take out the wire.

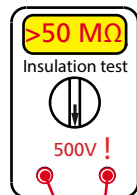
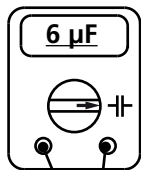
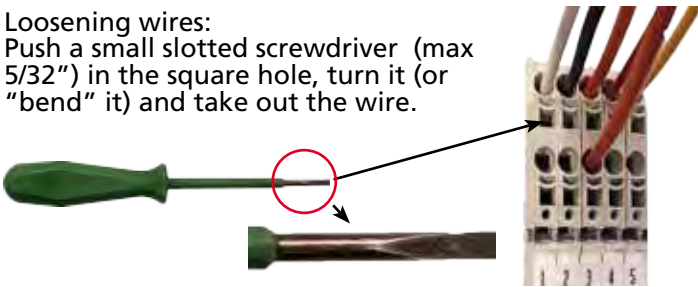

Charging with a test cable

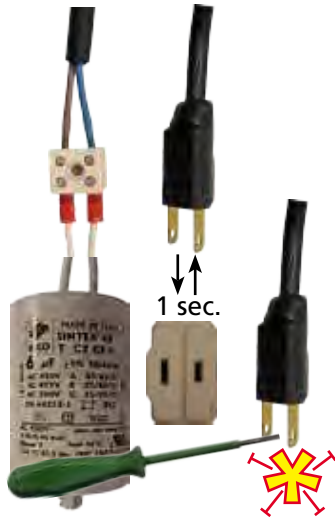

Checking with an Ω meter

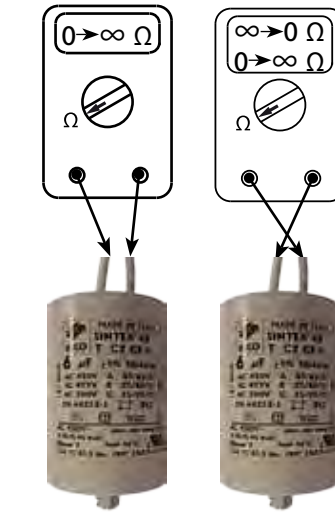

necting it to the mains supply (208V~). The same spark must arise. Do this a few times. The capacitor will not be charged when the leads are disconnected during the “zero crossing” of the mains sinus. It is ok when a spark arises once.

Measuring with an Ω meter.

Be sure that the capacitor is empty!

The value will go up until ∞ Ω is reached. Exchange the test leads. The value will go down, through “0” and up again.

If not, the capacitor is broken.

If ok, it is still not sure if the capacitor is ok. It might leak when it is connected to the mains power!

Active measurements.

You are about to measure on a 3 phase 208V~ circuit!! You need to be qualified for this! Always work according local legislations!

For measuring on the transformer terminal block:

- Use short test probes or-
 - Unscrew the terminal block and turn it outwards or-
 - Turn out the glass panel.
- Switch on the unit .

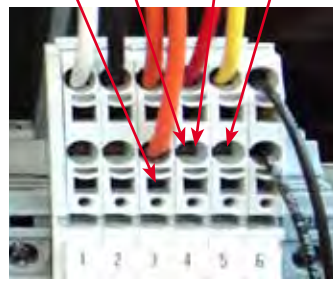
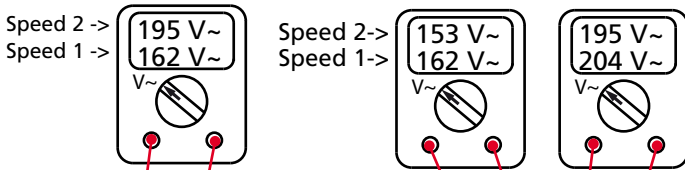

Voltagages that can be expected in normal situation.
All voltagages are related to a line voltage of 208V~

Blowers in high speed (speed 2 in cooking program):

- On the screw terminals of the blowers: 195V~
- On the terminal block
- Between Red (4) and Yellow (5): 195V~
- Between Red (4) and Orange (3): 153V~.

Blowers in low speed (speed 1 in cooking program):

- On the screw terminals of the blowers: 162V~
- On the terminal block
- Between Red (4) and Yellow (5): 204V~
- Between Red (4) and Orange (3): 162V~.

Trouble shooting with help of the I/O test facility (in case the fuses blew).

Do this test only when the above resistances are ok!!!

- Open the settings menu
- Choose service and give in the pin code 4878
- Select “I/O test” and choose MFMB outputs.

3 keys are available to test the blower outputs. The “X” numbers relate to the corresponding outputs on the circuit boards.

X3 is the relay that switches high and low speed. “1” is low speed. (mentioned wrong on the screen!)

X6 Switches full power on the transformer. **Do not use this one. It will blow the fuses!!**

X7 Switches 160V~ on the transformer (through the 22 Ω resistor)

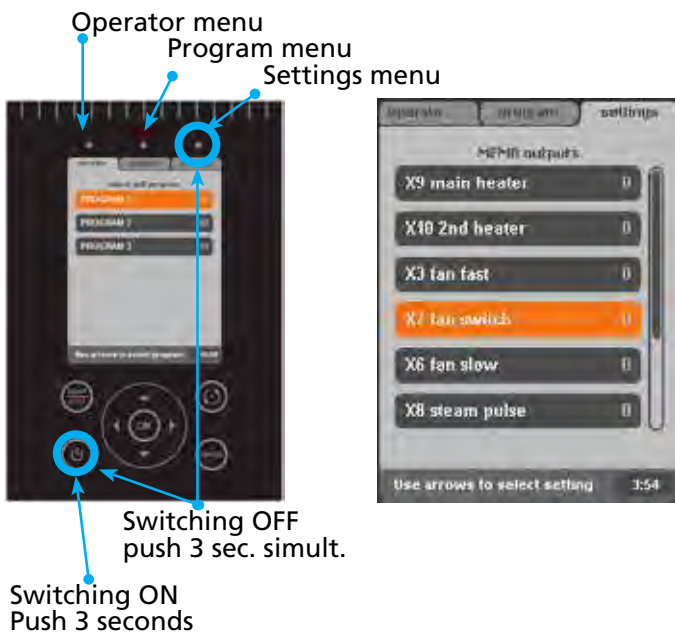

Output X7 active

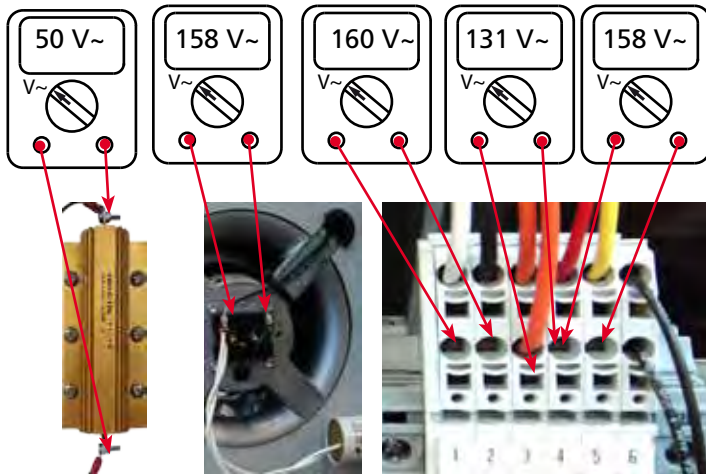

The duration of following test should only last for 3 seconds. In this time, the voltage over the resistor has to be measured!!

Therefore:

- Connect the Volt meter to the Resistor terminals with crocodile clamps or something like that and keep the meter in the neighbourhood.
- Activate output X7, read out the meter and deactivate the output as quick as possible. (activate the output by selecting it, push "OK" to activate and push "OK" again to deactivate.)

Note that you can use the emergency switch to quickly switch OFF in case you loose control.

-->In case the reading is higher than 60V~ there is a short circuit (insulation error) in the transformer or the blowers and the resistor will overheat!!

Proceed as follows.

1. Disconnect the 2 capacitors and unscrew them from the blower suction channel. (Metric 13)
2. Remove the grommet and take out the hose.
3. Unscrew 2 nuts (metric 10) and 2 bolts (with nut, metric 8) and remove the blower suction channel
4. Connect the 2 capacitors.
5. Disconnect both blowers. Therefore disconnect wire 60 from terminal X3.
6. Do the above test again and activate output X7. **Not longer than 3 seconds!! Wait 60 seconds in between measurements to let the resistor cool down**

- In case the voltage over the resistor is now $\pm 50V\sim$, the short circuit is in one of the blowers.
- In case the voltage is still high, the short circuit is in the transformer.

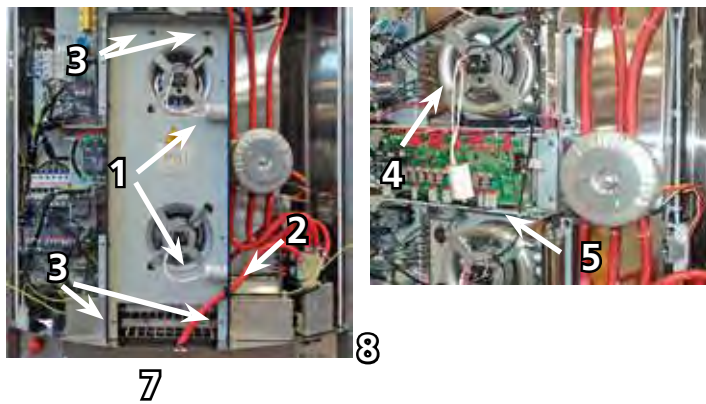

Blowers in full speed

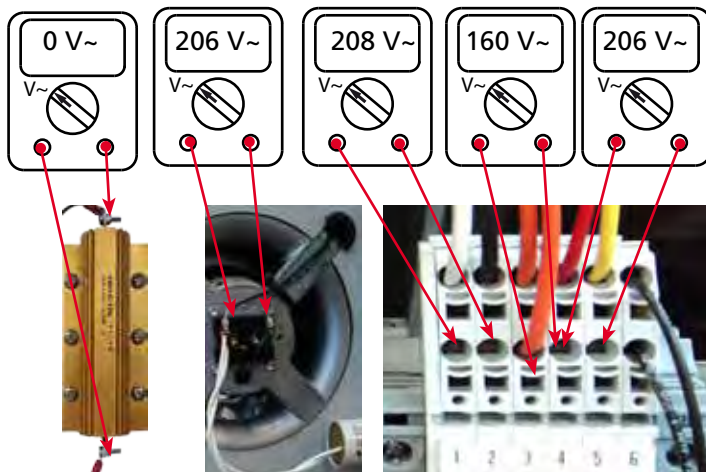

-->In case the reading is OK (50V~):

Output X7 can now be activated continuously.

Proceed as follows.

Measure the voltages.

- Over the resistor 50V~
 - On the screw terminals of the blowers: 158V~
- On the terminal block
- Between White (1) and Black (2): 160V~
 - Between Red (4) and Yellow (5): 158V~
 - Between Red (4) and Orange (3): 131V~.

In case the above is ok, then do the same measurements again with full power on the blowers.

Therefore start up a cooking program with fan speed 2.

Measure the voltages.

- Over the resistor 0V~
 - On the screw terminals of the blowers: 206V~
- On the terminal block
- Between White (1) and Black (2): 208V~
 - Between Red (4) and Yellow (5): 206V~
 - Between Red (4) and Orange (3): 160V~.

MEASURING ON THE 3 WAY VALVE

Working principle.

The 3 way valve is turned into the drain (sewer) position at the moment that the cleaning program is started. Waste water goes into the sewer.

As soon as the cleaning program ends or is interrupted, the valve is turned into opposite direction back to the default cooking position. Grease will go down into the container.

The cooking position is activated by output X3 on the slave I/O board. (relay in OFF position)

As soon as the cooking position is reached, the contact inside the motor housing disconnects the motor and activates relay K7.

The contact of relay K7 closes and connects terminal X30 to X31 on the Pwr and I/O board. This is the feed back signal for the processor that the valve reached the cooking position

The cleaning position is activated by output X4 on the slave I/O board. (relay ON). When in position, the motor contact activates relay K8, the contact of K8 closes and connects terminal X16 to X17.

A 7-core cable provides the power and the signal wires for the 3 way valve.

Note that wire nr 2 is not used. It has been cut out the cable. The terminal block inside the motor housing has the same numbers as the wires inside the cable.

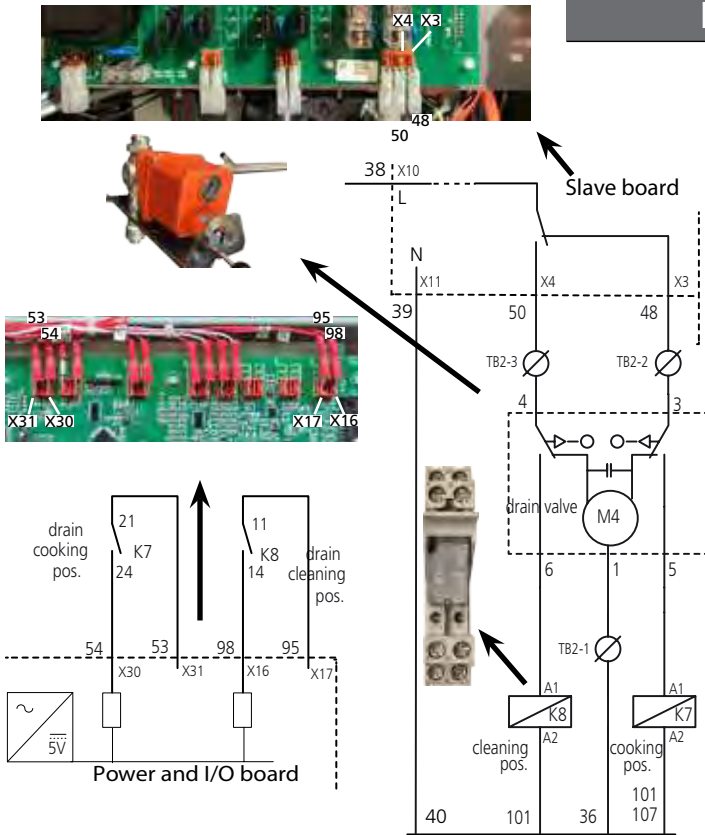

Typical resistance values without disconnecting wires!

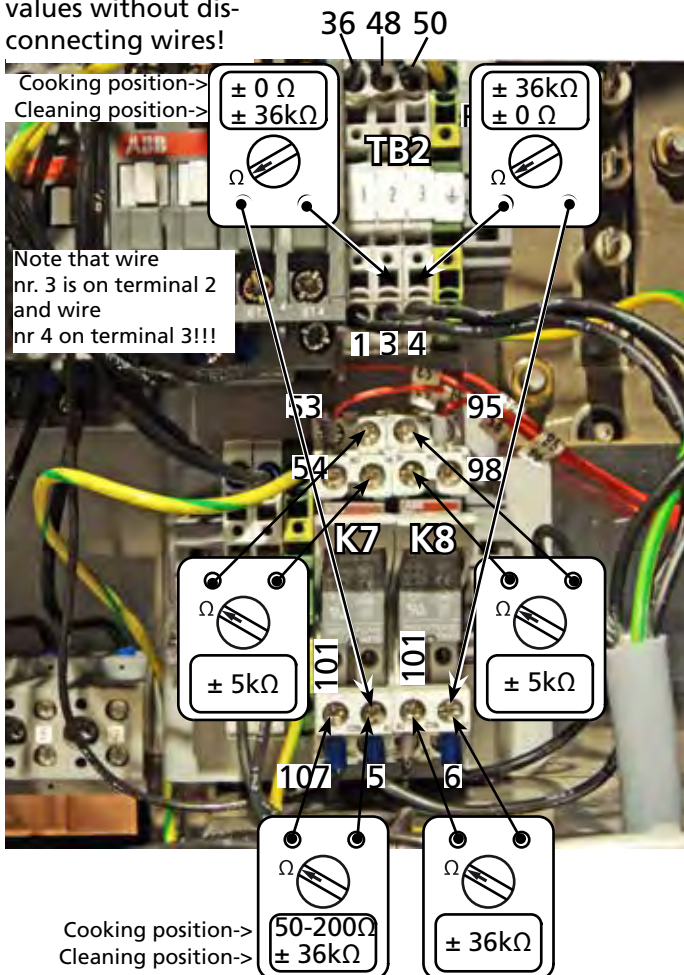

Passive measurements (resistance)

Disconnect the mains supply first!

The picture overview shows which measurements can be expected without disconnecting wires.

Disconnect wire "1" from the terminalblock (TB2-1) for further measurements!

The 3 way valve in cooking position. (normal position)

Between 1 and 3	$\infty \Omega$
Between 1 and 4	5000 Ω (Motor of valve)
Between 3 and 4	$\infty \Omega$
Between 3 and 5	$\pm 0 \Omega$ (Feed back signal)
Between 4 and 6	$\infty \Omega$

The 3 way valve in cleaning position.

Between 1 and 3	5000 Ω (Motor of valve)
Between 1 and 4	$\infty \Omega$
Between 3 and 4	$\infty \Omega$
Between 3 and 5	$\infty \Omega$
Between 4 and 6	$\pm 0 \Omega$ (Feed back signal)

The 3w. valve in between cooking and cleaning pos.

Between 1 and 3	5000-6000 Ω (Motor of valve)
Between 1 and 4	5000-6000 Ω (Motor of valve)
Between 3 and 4	1000-1200 Ω (Motor of valve)
Between 3 and 5	$\infty \Omega$
Between 4 and 6	$\infty \Omega$

Note that the resistances of the motor can reach 6000 Ω and 1200 Ω after a run. The motor is thermally protected.

Power & I/O board inputs

Relay K7 and K8

 Between A1 and A2 $\pm 36 \text{ k}\Omega$
Power and I/O board inputs

 Between X16 and X17 $\pm 5 \text{ k}\Omega$

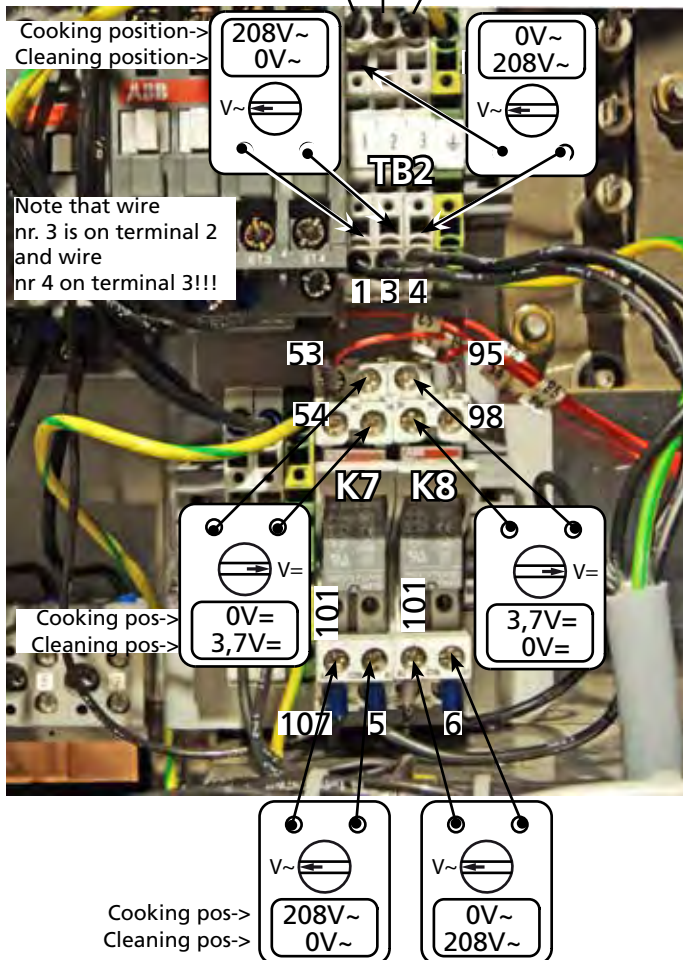
 Between X30 and X31 $\pm 5 \text{ k}\Omega$
Typical voltages

Active measurements (Voltages, ~ and =)

When the unit is switched on, the valve will turn into cooking position or is already there. Check the voltages with the values as shown on the picture.

Put the valve in cleaning position with help of the I/O testfacility -->Activate X3 X4 on the MFMB board. Check the voltages with the values as shown on the picture.

Trouble shooting.

Proceed as follows: (X3-N means "between terminal X3 and terminal X11 (marked "N") on the slave board)

Measure	Value	If Not ok
Valve in cooking position		
X3 - N (X11)	208V~	Board failure or N & L (X10) exchanged on mains terminals of board.
Wire 3 - N	208V~	Wire 48 or 3 disconnected
Wire 3 - 1	208V~	Wire 1 disconnected from Neutral.
Coil K7	208V~	Valve problem
Contact K7	0V=	Relay problem
X30 - x31	0V=	Wiring problem
If all ok		Board problem (input side)
Valve in cleaning position		
X4 to N	208V~	Board failure or N & L exchanged on mains terminals of board.
Wire 4 - N	208V~	Wire 50 or 4 disconnected
Wire 4 - 1	208V~	Wire 1 disconnected from Neutral.
Coil K8	208V~	Valve problem
Contact K8	0V=	Relay problem
X16 - X17	0V=	Wiring problem
If all ok		Board problem (input side)

Fuse 0,5A 5x20mm →

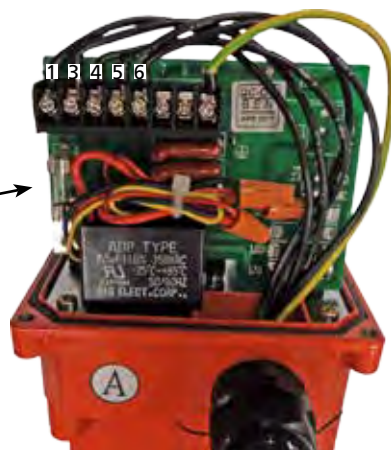

3 Way valve test rig.

The figures show the two positions and how they can be recognized.

With help of a self made test rig, it is possible to check the functions manually.

Take care of the necessary safety precautions!!

Power (208 V) between wire 1 and 3 will put the valve in operation position. The indication arrow will turn clockwise (cw) while the valve will turn ccw.

In this position, when the motor has stopped, there will be 208V between wire 1 and 5. (feedback signal)

Power between wire 1 and 4 will put the valve in drain position. The indication arrow will turn counter clockwise (ccw) while the valve will turn cw.

In this position, when the motor has stopped, there will be 208V between wire 1 and 6. (feedback signal)

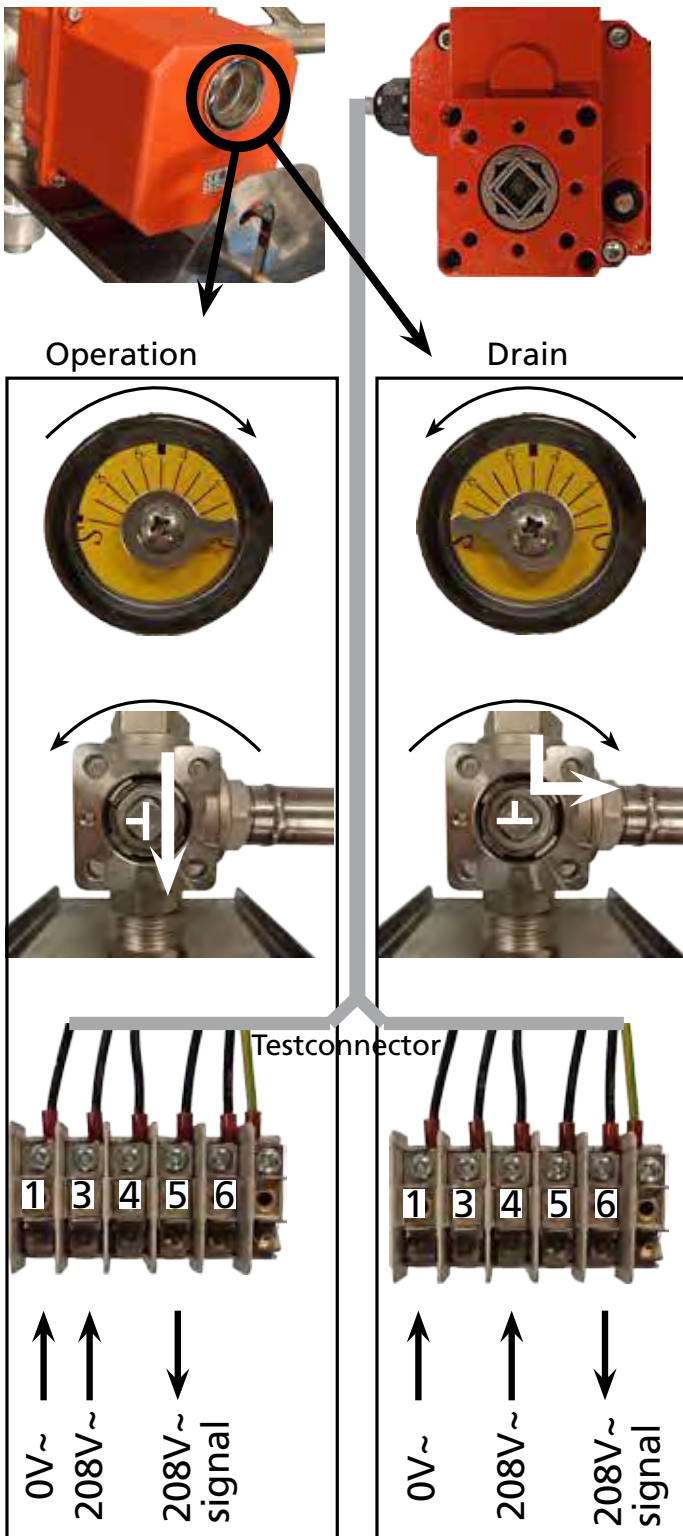

MEASURING ON THE HEATERS

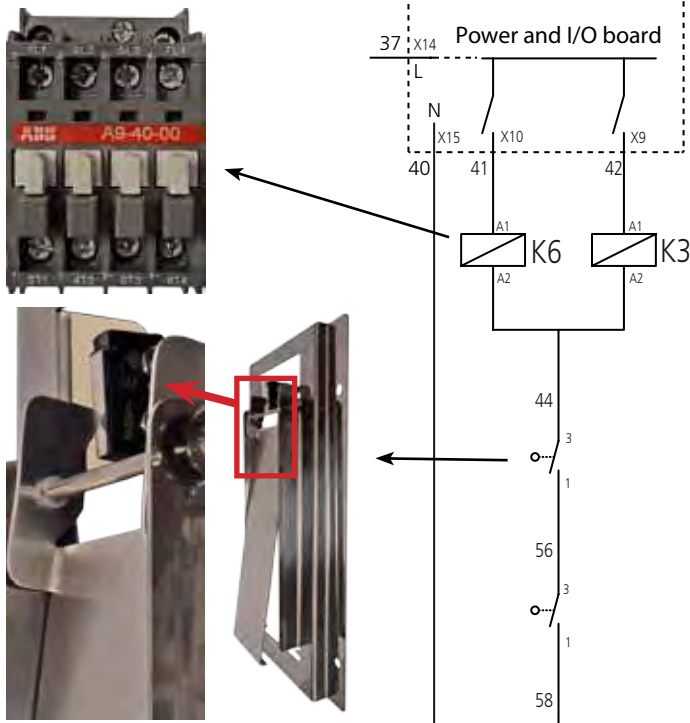

Working principle.

The temperature is measured by two PT1000 sensors. The upper sensor controls the top heater and the lower sensor controls the lower heater.

Therefore, two separate contactors are controlled by the board.

Blower malfunction overhear protection!

- A vane switch is mounted on each blower to detect the minimum rotationspeed.
- Both switches are put in series with the neutral side of the contactors.
- The contacts only close when the blowers speed is high enough.

Passive measurements.

Contactor

Between A1 and A2 $\pm 600\Omega$

Heating element (208V, 10kW -> 3x 3,33kW -> 3x 16A)

The picture shows how the heating elements are connected on the terminals.

- Each element is $\pm 13\Omega$
- The insulation of each element has to be $> 1M\Omega$.

Active measurements

On the contactor coils 208V

On the heater:

- 208V on each element.
- 16A on each element.

Trouble shooting.

Start up a cooking program and be sure that the set temperature is higher than the cooking cavity --> "asking for heat".

Proceed as follows: (X9-N means "between X9 and terminal X15 (marked "N")

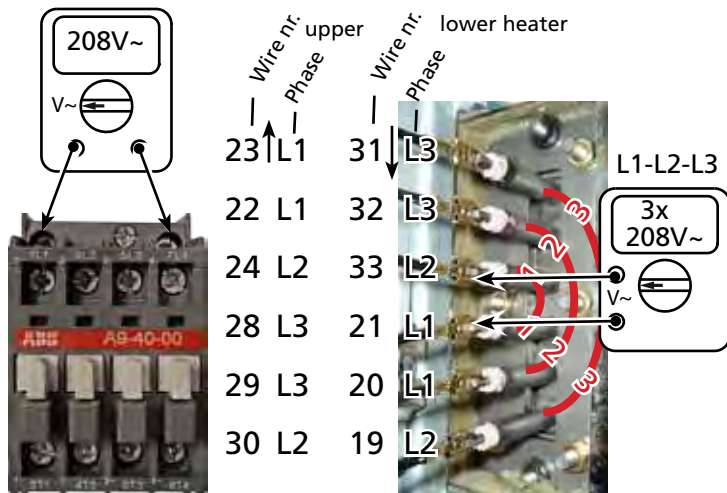
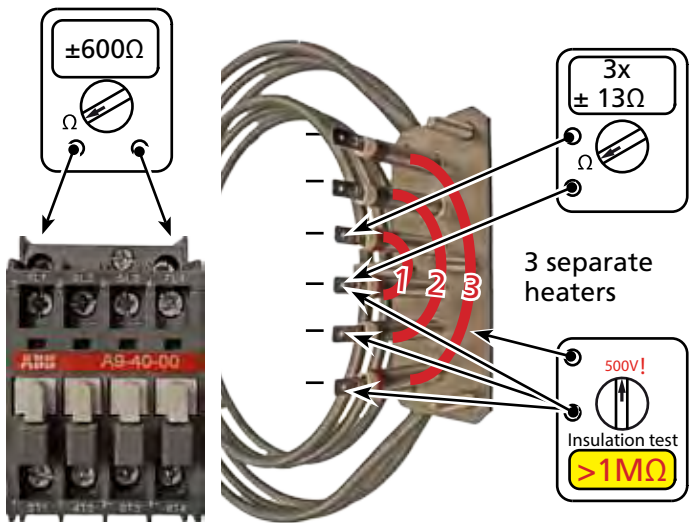

Measure	Value	If Not ok
X9 - N	208V~	Board failure or N & L exchanged on X14 and X15.
K3(A1) - N	208V~	Wire 42 disconnected
K3(A2) - N	0V~	Open vane switch or loose wire.
K3 = On?		Broken contactor
X10 - N	208V~	Board failure or N & L exchanged on X14 and X15.
K6(A1) - N	208V~	Wire 41 disconnected
K6(A2) - N	0V~	Open vane switch or loose wire.
K6 = ON?		Broken contactor
Stop the cooking program!		

MEASURING ON THE ILLUMINATION

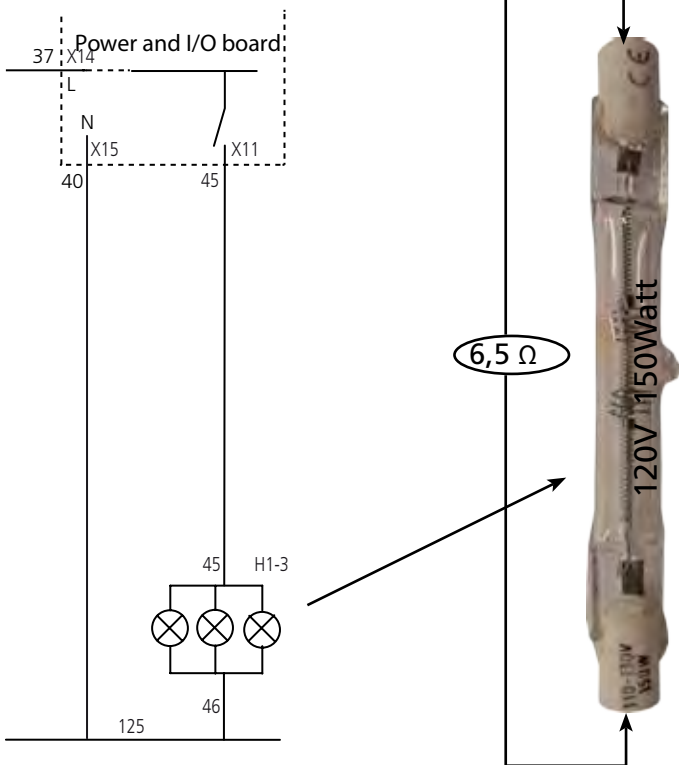

Working principle.

To increase the lifetime of the halogen lamps, there is chosen for a voltage of 120V~.

The lamp

It's resistance is 6,5 Ω.

In circuit, a resistance of 2,17 Ω can be expected (3 lamps in parallel).

MEASURING ON THE ROTOR MOTOR

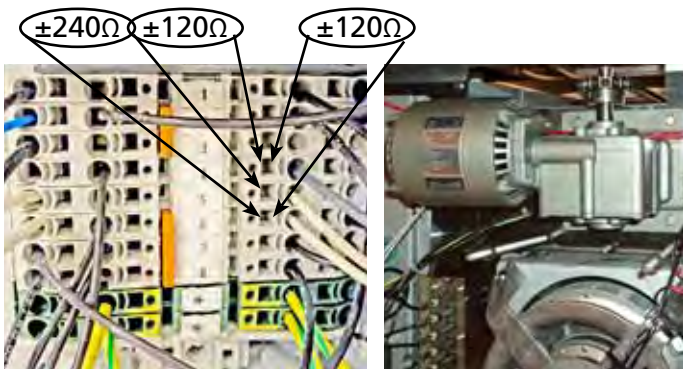

Working principle.

This motor has 2 equal coils of 120 Ω.

The coils are internal connected and the black wire is connected to this junction.

Exchanging the 2 white wires will change the rotation direction.

The motor needs to turn cw (clockwise), seen on the top of the cam shaft.

The resistances can be measured in circuit.

- Between black and white. 120Ω
- Between white and white 240Ω

MEASURING ON THE COMPRESSOR

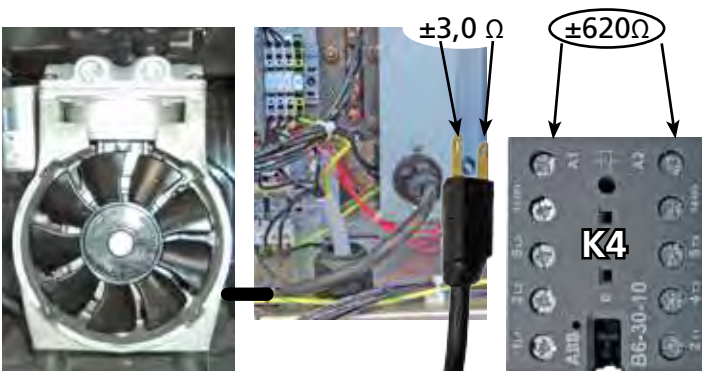

Working principle.

Relay K4 switches the compressor and is controlled by output x5 of the slave I/O board.

The resistances as shown can be measured when you pull out the plug.

MEASURING ON THE WATERVALVES



Working principle.

There are 6 watervalves mounted in the unit. A double inlet valve and a quadruple valve.

Outputs on the Slave I/O board

Relay K5 switches the 2 waterinlet valves and is controlled by output X8 .

Output X7 controls the valve for the watersprayers in the center.

Output X6 controls the valve for the watersprayers in the side post.

Outputs on the Power & I/O board

Output X8 controls the two watervalves for the steam production.

These two valves are connected parallel and have a reducer mounted inside.

MEASURING ON THE AIRVALVE (VENT)



Working principle.

The motor is controlled by output X9 of the Slave I/O board.

Two cam switches give the feed back signals for the open or closed position.

The motor resistance is $\pm 10 \text{ k}\Omega$ and can also be measured in circuit.

MEASURING ON THE SAFETY CIRCUIT

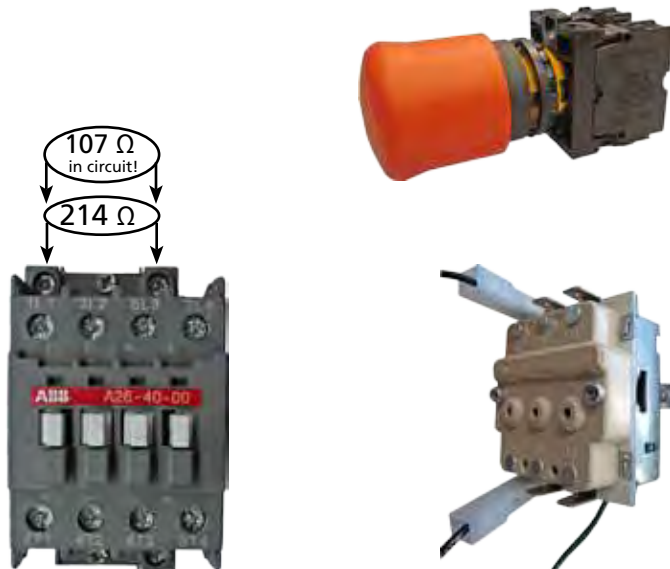

Working principle.

Two independant switches control the safety circuit.

- The emergency switch
- High limit thermostat

Both switches are in series with two contacters.

These contacters switch OFF all phases and Neutral lines in case the high limit trips or when the emergency switch is pushed in.

MEASURING ON THE PT1000 SENSORS

Working principle.

Two PT1000 sensors control the heat in the cooking cavity.

The upper sensor controls the upper heater and the lower sensor controls the lower heater.

A core sensor can be used for cooking on core temperature.

See below the resistance overview for the PT1000 sensors.

Note that the PT500 and PT100 sensors are also mentioned. This is just extra information. These are not used in the unit!

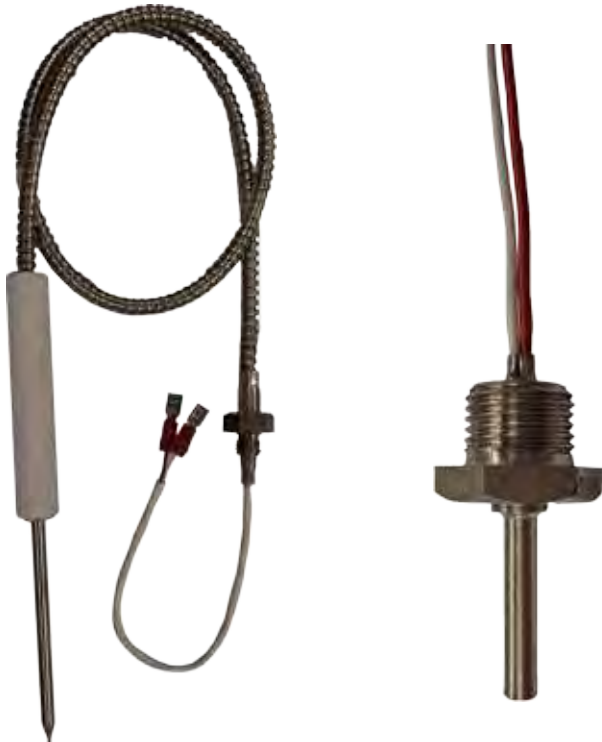

°C	PT100	PT500	PT1000
-50	80,31	401,55	803,10
-40	84,27	421,35	842,70
-30	88,22	441,10	882,20
-20	92,16	460,80	921,60
-10	96,09	480,45	960,90
0	100,00	500,00	1000,00
10	103,90	519,50	1039,00
20	107,79	538,95	1077,90
25	109,74	548,70	1097,40
30	111,67	558,35	1116,70
40	115,54	577,70	1155,40
50	119,40	597,00	1194,00
60	123,24	616,20	1232,40
70	127,07	635,00	1270,00
80	130,89	654,45	1308,90
90	134,70	673,50	1347,00
100	138,50	692,50	1385,00
110	142,29	711,00	1422,00
120	146,06	730,00	1460,60
130	149,82	749,10	1498,20
140	153,58	767,90	1535,80
150	157,31	786,55	1573,10
200	175,84	879,92	1758,43
250	194,07	970,35	1940,81
300	212,02	1060,09	2120,30

SERVICE SET CPU BOARD **9172552S**

CPU+LCD i-control
9172552

- 1) Mounting instructions
- 2) Adjustment of device type
- 3) Software update (only if needed)

Contents:

1x 9172552 CPU+ LCD+buzzer

4x 0149297 Spacer $\varnothing 4,2 \times \varnothing 8 \times 12$ (mm), nylon. 

4x 0188750 Washer 4,3x9x1,4, nylon

This instruction (4 pages)

This CPU board also replaces the 9172317 board (if applicable).

Note that this board needs longer spacers than the older 9172317 board. That is the reason that these spacers can be found in the package.

Mounting instructions:

- Gain access to the CPU board. *Follow instructions in the corresponding service manual, which can be found on the Fri-Jado website "www.frijado.com".* See next page for an overview of the equipment.
- Disconnect both key pad cables.
- Disconnect the ribbon cable. (connection with the I/O boards)
- Disconnect the earth wire.
- Unscrew the four M3 nuts.
- Take out the CPU board with LCD.
- Take out the spacers.

Note that the spacers can remain in case these have the right dimensions i.e. if the broken board was the 9172552 type.

- Reverse the procedure to mount the new CPU board.
- Start with placing the delivered spacers if applicable.
- After mounting the CPU board, and connecting the 3 cables and the earth wire, the unit has to be switched ON.
- Check if the board has been set to the right device type. Continue on the next page.



older CPU board



This CPU board can be applied in the below shown units.
It is very important to adjust the "device type" parameter to the right setting.
 Also refer to the service manual I-control.

STG-i
Super Turbo Grill



TDR-i
Turbo Deli Rotisserie



ACR
Auto Clean Rotisserie



Mtsr M-bake
Multisserie -Deli -Bake



BS-i
Bake Star



STO-i
Super Turbo Oven



TRC
Turbo Retail Combi



Overview of the control board.

Program tab

Settings tab

Operate tab

Switching OFF
Press both keys for 3 seconds.

Start / pause of program

Switching ON
Press for 3 seconds
-Press 6 seconds for key test.

Combination of dial and up - down - left - right keys

-Rotor key for positioning rotor
-Door open key in BSi

Confirmation or entering of choice.

Stop / cancel of program



Enter password
<OK> <OK>



adjust the device
type ↑↓



adjust language
↑↓ <OK>

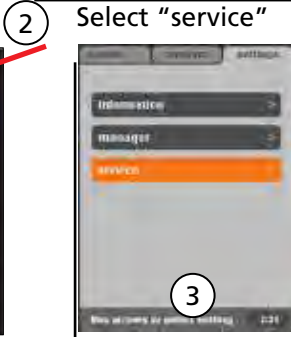

Select "device type"
↑↓ <OK>



example Multi
<OK> <OK>



select language
<OK>



Mounting the CPU+LCD board.

- Switch off the power
- Mount the new CPU board in the unit. Refer to page 1.
- Switch on the power.

Adjusting the device type.

1. Switch ON the unit. (push 3 sec.)
2. Push the <settings> tab.
3. Select "service"
4. Enter the password "4878"
5. Push <OK>
6. Push <OK> The screen opens default with the device type (BSi) selected.
7. Select "device type" (if necessary)
8. Push <OK>
9. Select the right device type with the <up / down> arrows. *Check on the frontpage which device type should be chosen.*
10. The example shows "Multi" (from Multiserie deli).
11. Push <OK>
12. Push <OK>
13. Select "set language" with the <up / down> arrows. (only if applicable)
14. Select the language of your choice.
15. Push <OK>
16. Push the <operate> tab.

By selecting the device type, all the parameters will be adjusted to their default!

Please go through the following page for updating the software!

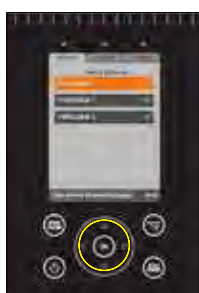

More information!

- Please refer to the service manual i-control for the latest parameter lists and more information about this controller.

- **Also check for the latest software version!**

Both can be found on the Fri-Jado website "www.frijado.com" in the distributor area.

How to read out the software version (firmware).

1. Switch ON the unit. (push 3 sec.)
2. Push the <settings> tab.
3. Select "information"
4. Read out the version

How to read out the bootloader version.

1. Disconnect the mains supply.
2. Connect the mains supply.
3. Read out the bootloader version.

Updating systemsoftware (firmware). Only if needed!!

This software, supplied by Fri-Jado comes in a "zip" file with the version number of the software, for example "V5_00_13.zip". The file needs to be copied on a USB stick. (disk "STORE N GO (F:)" in the example)

After unpacking it, the folder named "42-I+CPU" needs to be moved or copied to the root of the USB stick as shown below.

==> **Untill software version V5.xx.xx can be used on all boards (with USB port)**

==> **For software version V6.xx.xx, bootloader version 1.02.02 or higher, is necessary.**

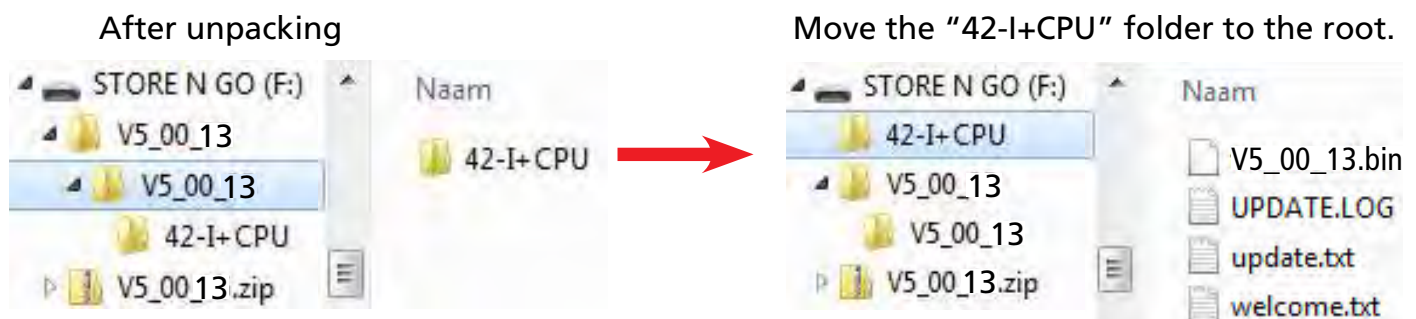

Now proceed as follows:

1. Switch OFF the mains supply or pull the mains plug.
2. Connect the usb stick.
3. Switch the power back on or put the mains plug back in. You will see that the controller detects the software and starts uploading
4. You will be asked to remove the stick and when done the unit switches off. (the existing parameters will remain).
5. **In case the board has just been put into a unit, it has to be set to the right device type!!!!** This has to be done in the service menu. Refer to the previous page.

SPEED TRANSFORMER UPGRADE KIT 9190193S



Contents kit:
 9190193 1x NTC assembly.
 (as shown)
 9191254 1x Terminal numbers
 0260155 1850mm wire AWG18

Applied in:

Deli Multiserie

Bakery Multiserie



Open the service doors.



Remove the air channel



TB1

TB3

Wires 108 and 109

Note *1

Wires 127 and 128, when mentioned, are only applicable in case the unit has a condensing hood

- **Move** wire 128 *1 from #2 to #5
- **Move** wire 59 from #2 to #4
- **Remove** terminal numbers
- **Disconnect** the black wire.
- Loosen the endclamp and move #1
- **Place** the NTC assembly
- **Remove** #2

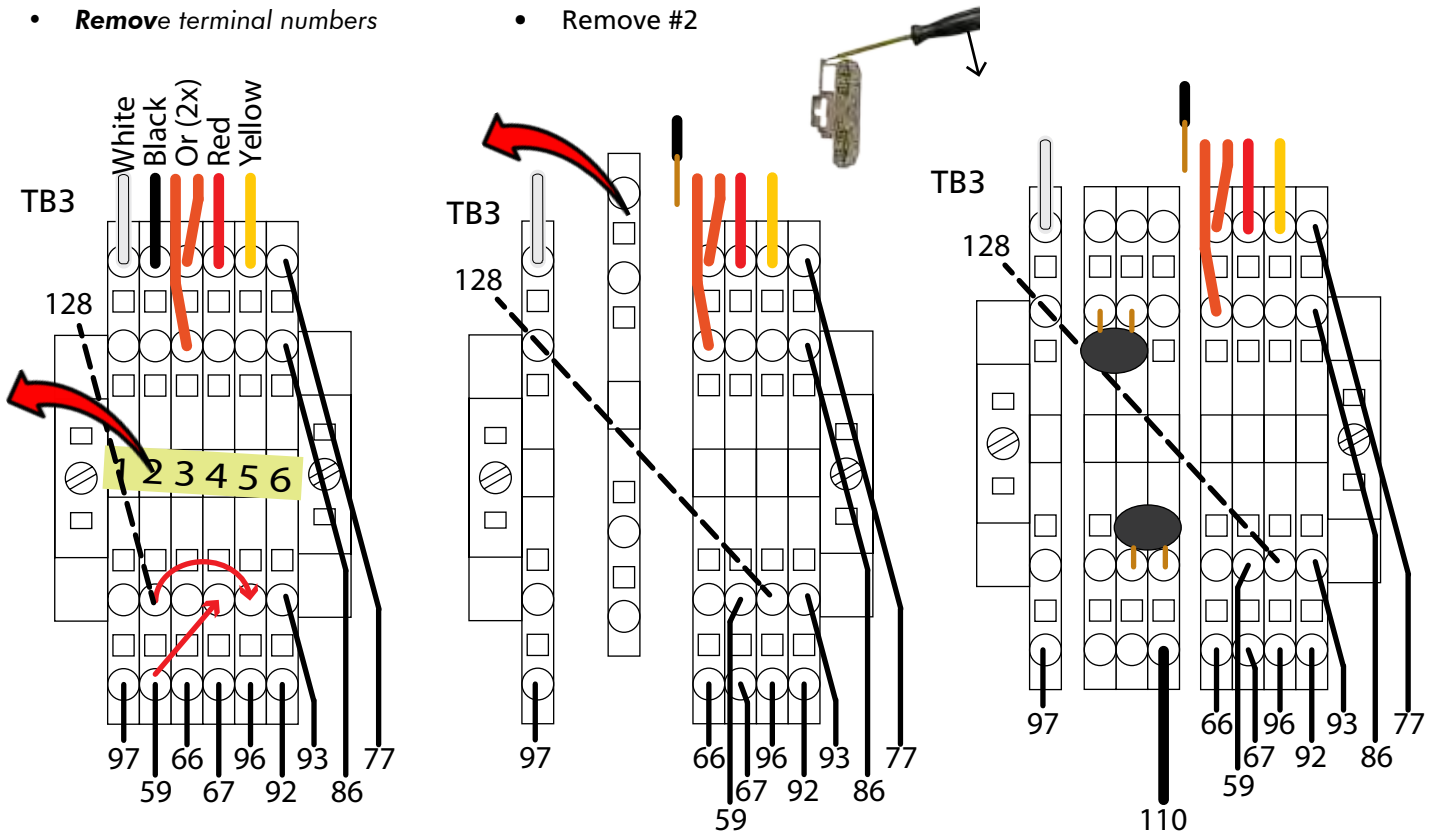

- **Slide** the block together
- Place the # numbers.
- Connect the black wire to #2
- **Move** the red wire to #4
- Connect wire 127 *1 to #6

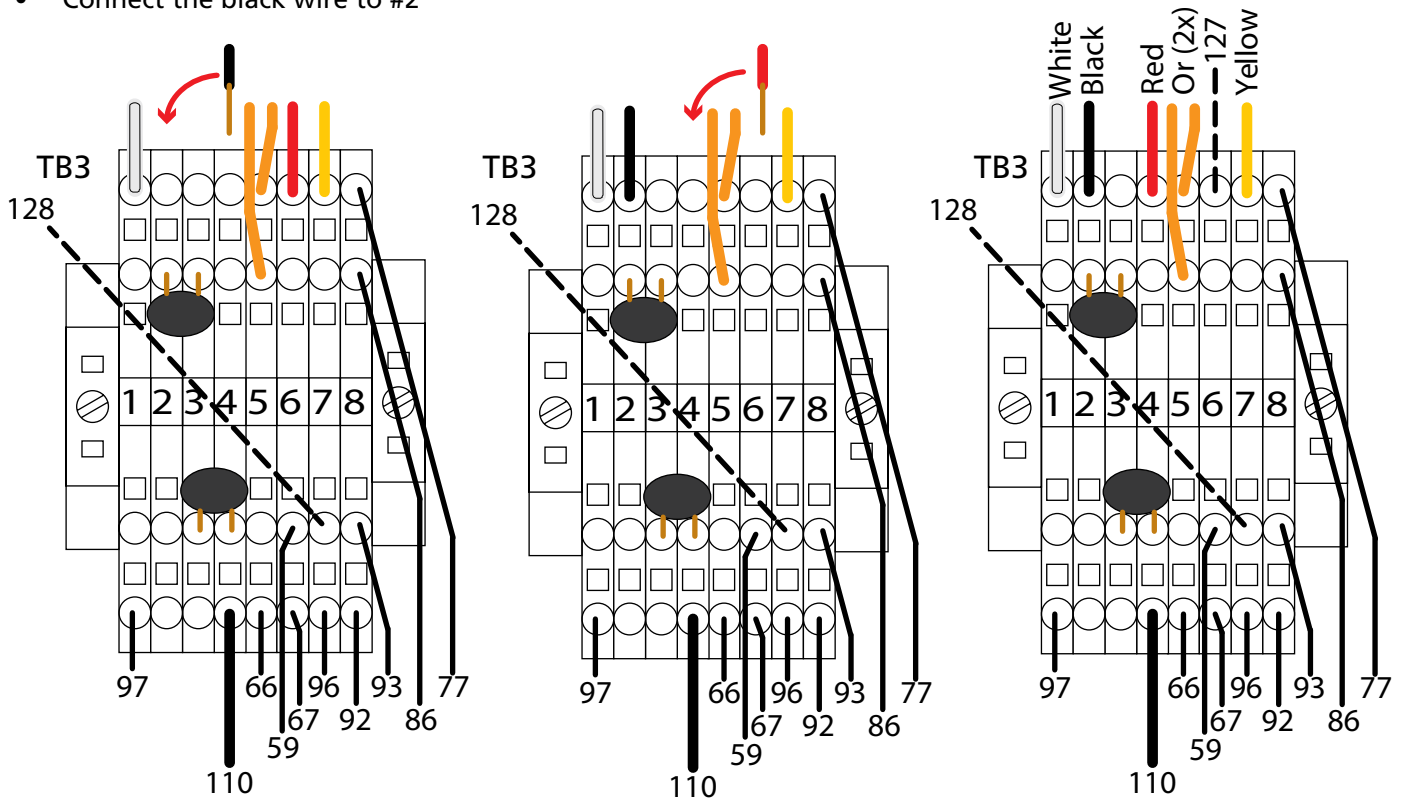

- Connect the new wire 110 to #1 from TB1
- Disconnect wire 127 *1 from #8
- Connect the delivered extension wire 127 *1, to the one coming out of #8 from TB1

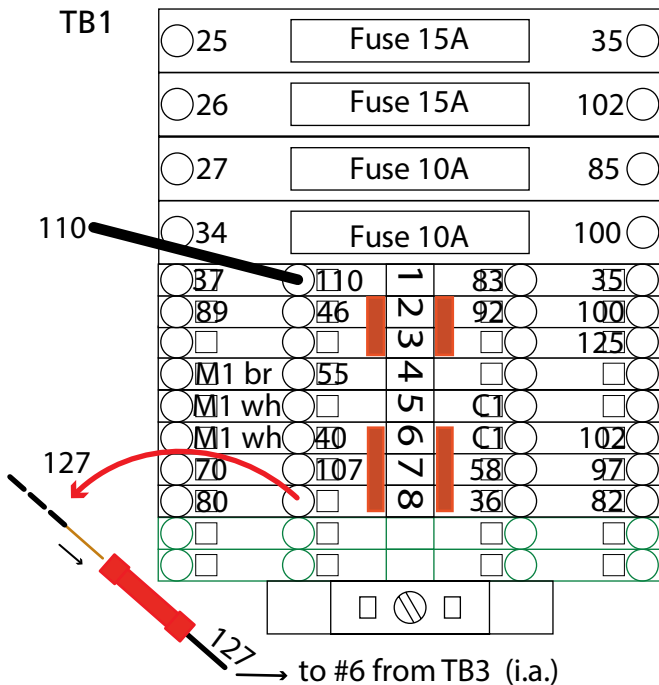

- **Disconnect** the wires 108 and 109 from terminal x7 and x6 and remove them.

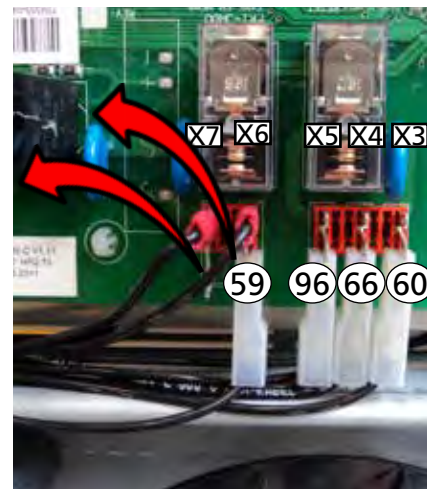

*1 Wire 127 and 128 are only used in case of a condenser hood!!

SOAP BOTTLE CAP

From 2010, the soap bottle cap has been improved. The new swivel construction makes it easier to exchange the soap bottle.

Note: The colour of the cap can differ according to the country.

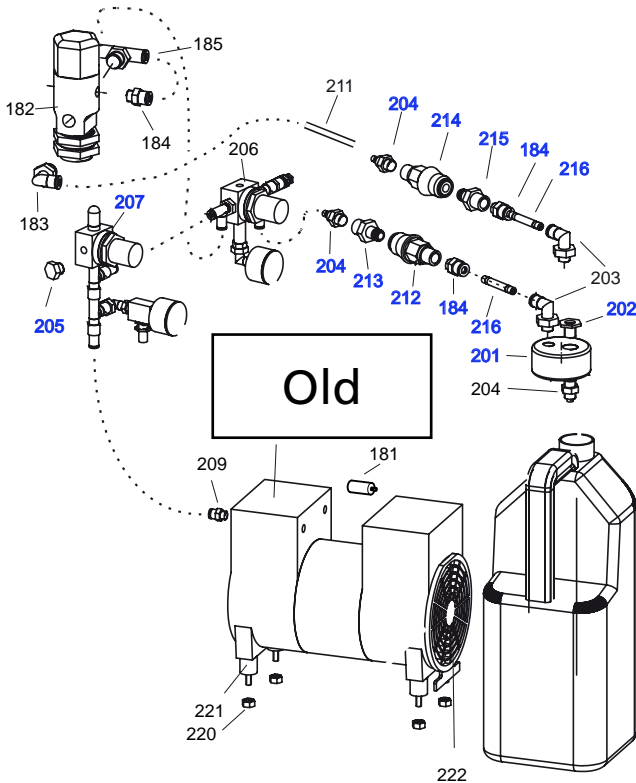

Removed are: (in blue)

184	9191183 2x	Straight adapter
201	9192220 (Eur cap) 9192250 (US)	
202	9191169	Nipple adapter
204	9191171 2x	Straight adapter
205	9191185	Plug
207	9192248	Pressure reg. 2,5Bar
212	9191179	Quick dc fem black
213	9191180	Quick dc male black
214	9191166	Quick dc fem transp
215	9191167	Quick dc male trans
216	9192257 2x	Connection pipe

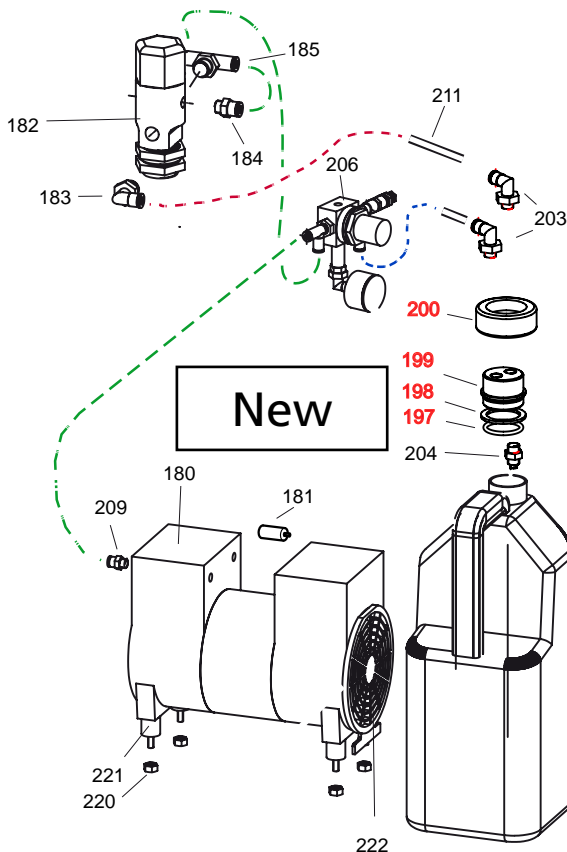

New parts are: (in red)

197	O-Ring	9191283
198	Ring	9192344
199	Plug	9192341
200	Swivel	9192340

Explanation tube colors.

Green	High pressure
Blue	Low pressure (250 mBar)
Red	Soap

SERVICE SET 9190131, SOAP BOTTLE CAP

Since January 2010, this soap bottle cap has been improved. The new swivel construction makes it easier to exchange the soap bottle.

Note: The cap for use in the USA is black colored.



Swivel cap
US part nr.
9190131

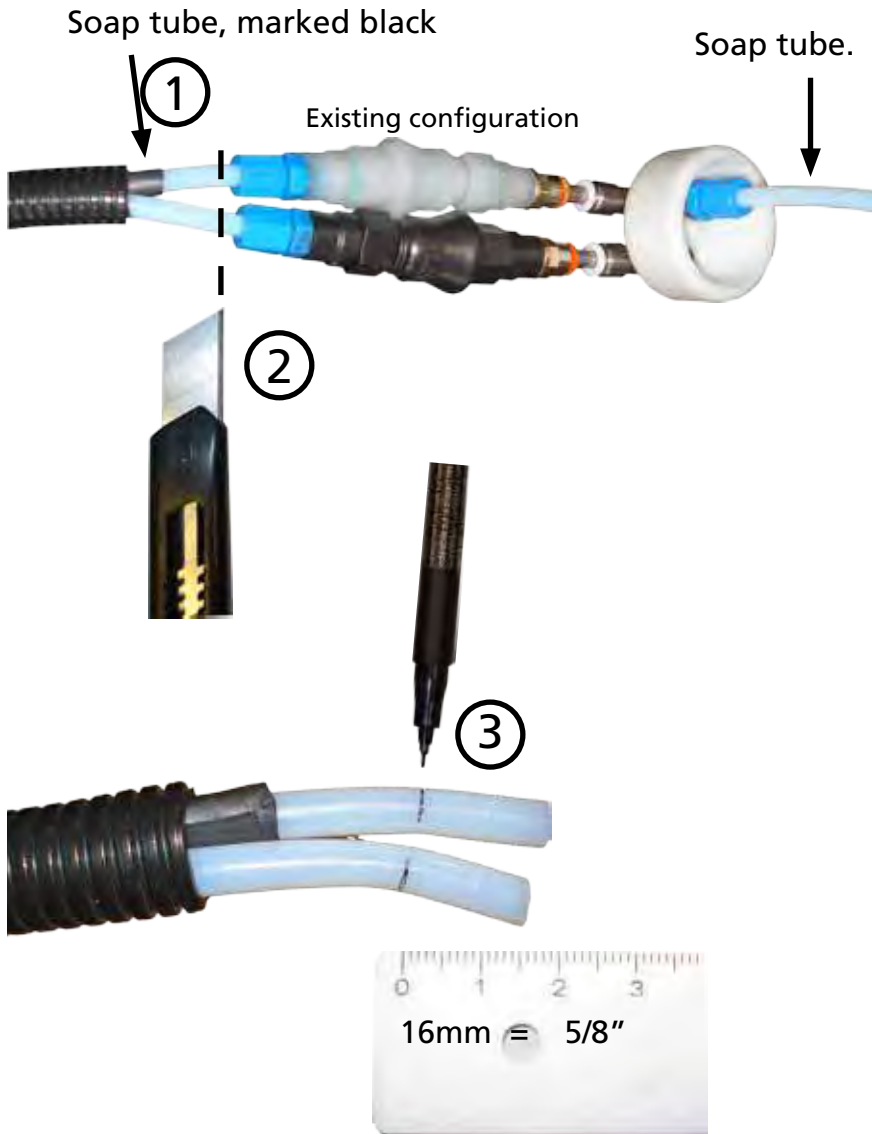

Description:

1. Check if the black mark is present. Mark with tape or pen if necessary.
2. Cut both tubes close behind the blue connectors.
3. Place a mark on both tubes, 16mm (5/8") from the cutted end.
4. Push the tube with the black tape into the connector with the black tape. Push firmly until the mark (3) equals the connector.
5. Do the same with the other tube.

Note:

In case of a mistake, the tube can be removed from the connector by firmly pushing the white ring towards the connector and then pull out the tube.

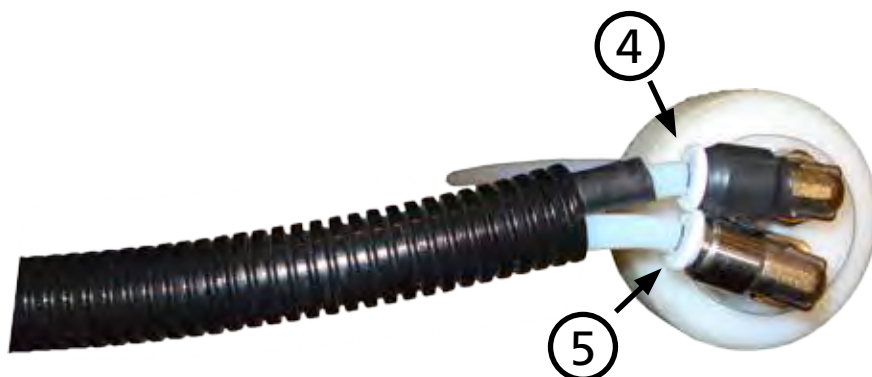

SERVICE SET 9191292S, REVISION OF SOAP MISTER

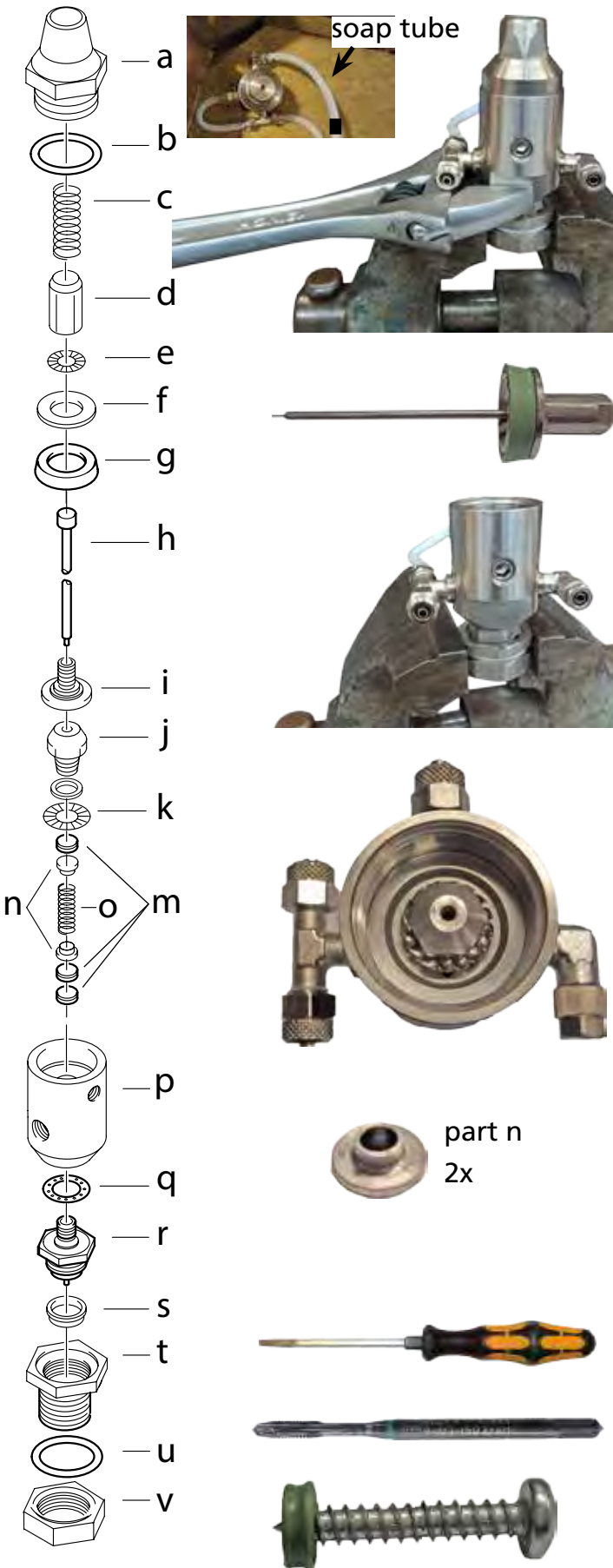

Contents: parts b, g, m(3x), q, u and a sheet metal tool.

Open the top of the unit and disconnect the 2 hoses from the soap mister.

The soap tube is marked with black tape.

Open the door and unscrew the mounting nut (v). (32mm wrench).

Take out the soap mister.

The use of a vice is advised to make the job easy, but it is not necessary. The description below is with the use of a vice.

- Put the mounting nut back on the mister.
- Clamp the mister with the mounting nut (v) in the vice.
- Unscrew the cap (a) while holding the body (p) of the mister with a 28mm wrench (on the 2 flat surfaces as shown).

Note that the cap is spring loaded.

- Remove the cap with o-ring (b) and the spring (c).
- Pull out the plunger with the needle.
- Unscrew the o-ring cap (j).

Note that it will be spring loaded.

Note 2: Small collar bushes (n) might fall out.

Note 3: Sometimes an extra spacer is mounted between j and k.

- Take out the spring (o).
- Take the metal collar bushes (n) out of the o-ring cap (j) and also out of the soap mister body (p).
- Take out the o-ring (m) from the o-ring cap.
- Take out 2 o-rings from the soap mister body (p).



Note that the o-rings might be deteriorated, hardened or completely disappeared. With a small (slotted) screwdriver, it is possible to break the o-rings in pieces in order to take them out. Some times, a self tapping screw (or small (M3) tap) can be used to pull out the o-rings.

Tool
9194913



- Unscrew the soap mister body (p) from the nozzle (r)
- Take away the ptfе gasket (q)
- Unscrew the nozzle (r) from the holder (t)
- Take out the air spout (s).
- Take the holder and mounting nut (t-v) out of the vice.

Disassembling the plunger and needle.

- Bend the delivered plate double as shown in order to make it a tool.
- Put the the plunger with needle on the tool.
- Put the assembly in the vice as shown. Clamp the vice until the plates of the tool touch the needle. Do not put much force on it to prevent the needle from damaging. (in case no vice is available, a big adjustable wrench could be used, see picture).
- Unscrew the capnut (d)
- Take the lock washer (e), the big washer (f) and the cuff from the plunger (i).
- Pull the needle (h) out of the plunger (i).

Note 1: The needle will be sealed with thread sealant to prevent air leakage on that point.

Some force might be necessary.

Note 2: In case the needle does not need to be replaced and the sealant is still ok, you can leave the needle in the plunger (i)

- Clean all metal parts!
- Often, just water is enough.

Necessary tools.

- 10 mm wrench for part d and the soap tube connector.
- 12 mm wrench (air tube connector.)
- 13 mm wrench for the o-ring cap (j)
- 21 mm wrench for the cap (a)
- 28 mm wrench for the body (p)
- 32 mm wrench for the holder and nut (t-u)
- Small slotted screwdriver to break hardened o-rings.
- M3 tap or 3mm selftapping screw to pull o-rings

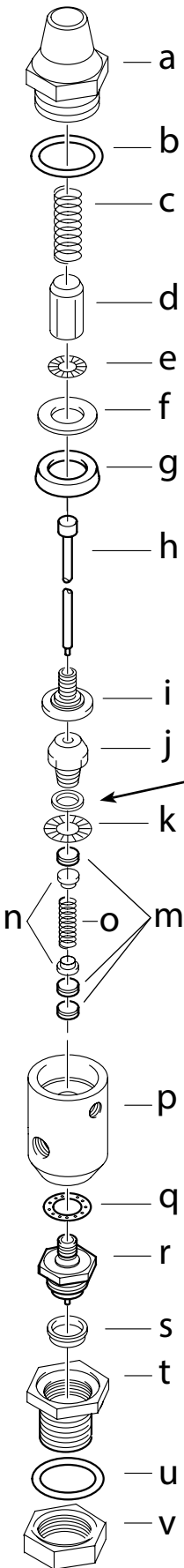

Assembling the needle with the plunger.

Basically this is in reverse order of disassembly.

- Thread sealant needs to be applied as shown to make the assembly air-tight.
- Now place the cuff (g), the washer (f), the lock-washer (e) and the capnut (d).
- Bend and place the tool in the slots of the plunger (i) and clamp the assembly in the vice.
- Tighten the capnut (d). The needle should not have slack anymore.

Mounting the needle into the body (p).

- Apply some ptfе tape on the o-ring cap (j).
- Apply some lubricant on the needle and make an assembly of the parts d through m as shown.

Note that under the head of the o-ring cap (j), sometimes an extra spacer might have been applied (between j and k). Reuse that if applicable.

- Place the assembly in the body.
- Push the o-ring cap (j) down and turn until the thread catches.
- Tighten the o-ring cap (j).
- Assemble the rest of the soap mister.

Mount the soap mister back into the unit.

Note 1: In case a new ptfе o-ring (u) is used, the nut (v) needs to be re-tightened after the unit has been heated up!

Note 2: the single connection is for the soap, marked with "liquid".

The soap tube is marked with black tape.

HINGE REPAIR KIT 9190565

Since May 2011, serial number 100052917, M6 bolts are used to mount the door hinges. In case in older units, the M5 screws don't hold anymore, this kit can be used.

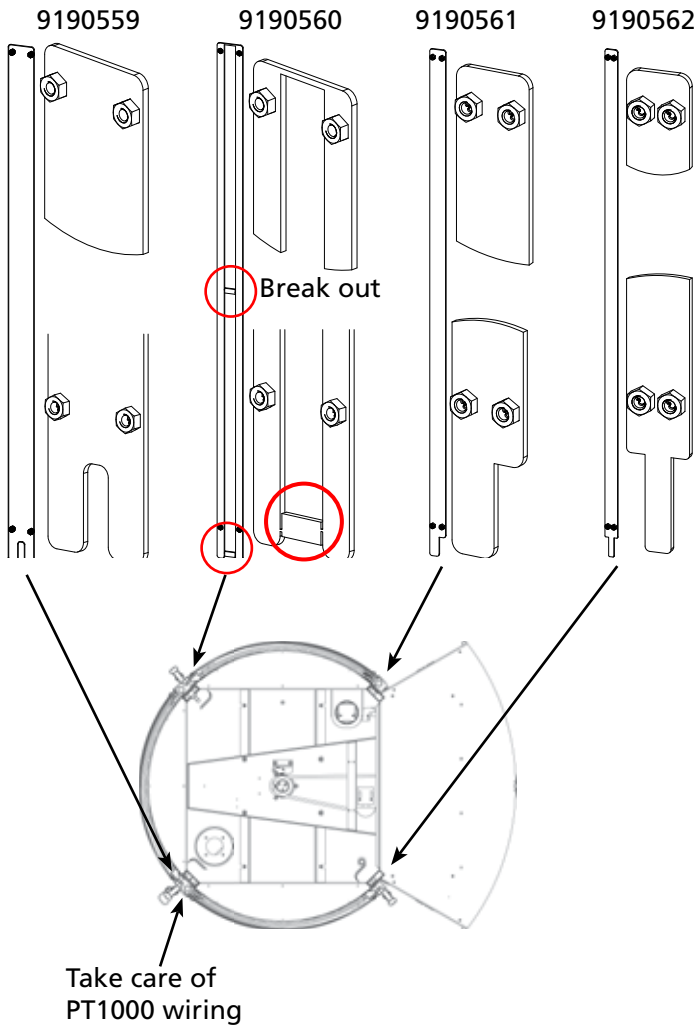

Top view detail

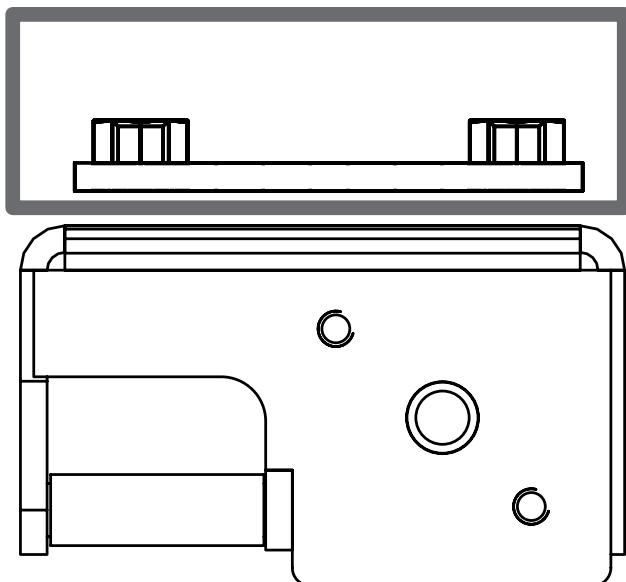

Mounting description

1. Take out the inner door.
2. Remove the top hinge.
3. Remove the outer door.
4. Remove the bottom hinge
5. Do this for all 3 doors.
6. Drill out the M5 rivet nuts.
7. Tick the remainings inwards the post.
8. Remove the square top plate.
9. Put the enforcement strip in the corresponding door post.
10. Mount the hinges back with the M6 bolts.

Points of attention:

The welded nuts have to point to the center of the unit. See top view detail.

In case it does not reach the bottom, caused by the remainings of the rivet nuts, let it fall into the post. This will usually move the rivet nuts out of the way

Remarks:

9190559 has a slot at the bottom side, which is necessary for the PT1000 sensor in that post. Take care of the PT1000 wiring!

9190560 has 2 "nock-outs". These need to be removed just before placing next to the side post sprayer pipe.

RINSE AGENT KIT 9190198S

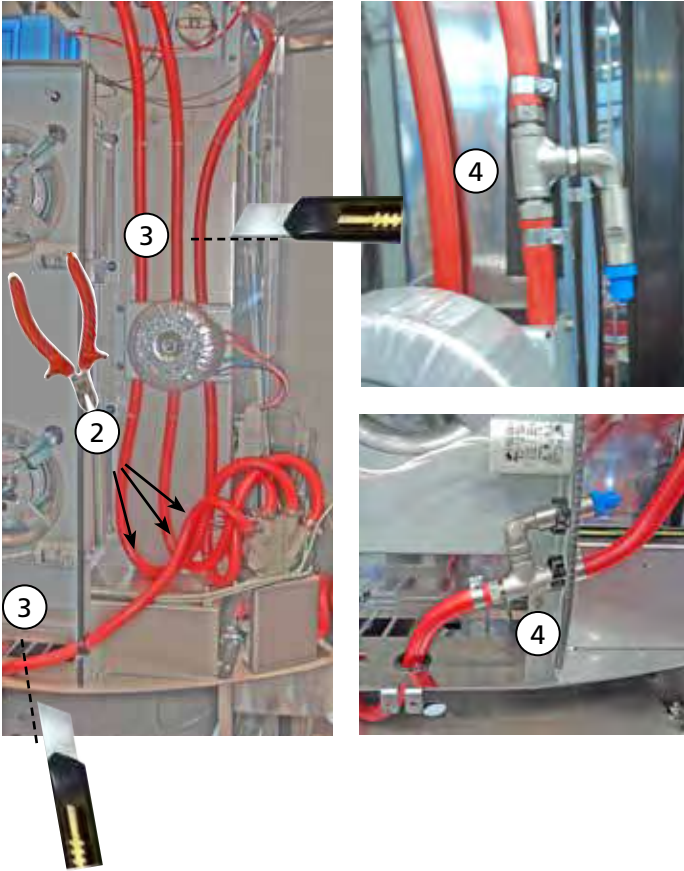

- 1) Open the service door at the back.
- 2) Cut the 3 cable ties, see arrows.
- 3) Cut the 2 hoses as indicated with the knife.

- 4) Connect the 2 rinse agent injection assemblies as shown in-between the hoses.

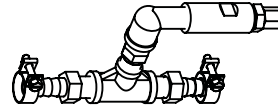

- 5) Mount the Pump assembly.

- 6) Guide all water hoses as shown. Shorten if necessary. ==> Very important is that they cannot block the vane switches!!

- 7) Connect the hoses for the rinse agent as shown on the next page.

- 8) Connect the wiring from the pumps to the corresponding solenoid valves as shown.

==>The pumps have to pump the rinse agent into the flowing water!

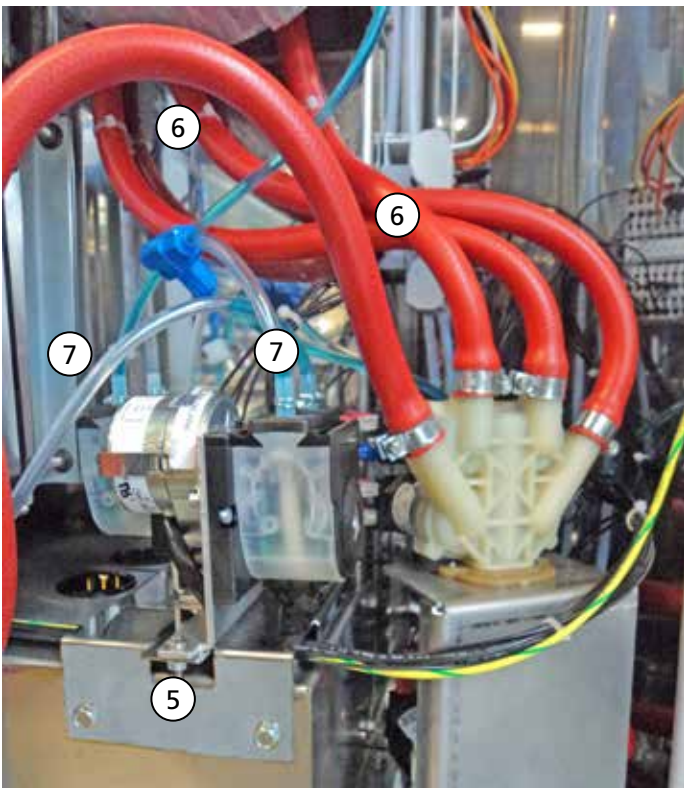

Connection overview

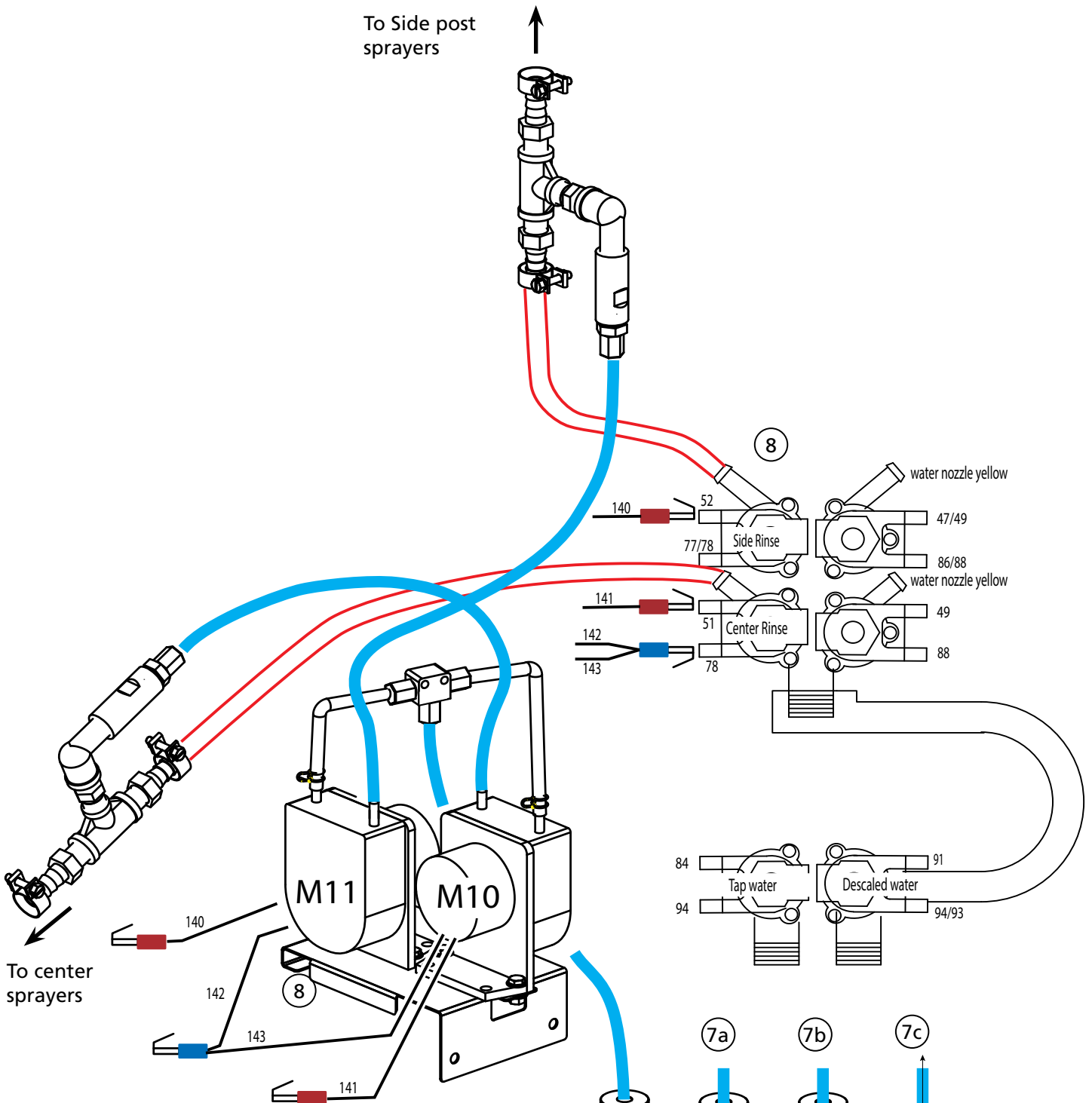

- 7a) Push the hose through the immersing weight.
- 7b) Push the stiffener sleeve into the hose.
- 7c) Pull the hose upwards until it gets stuck.

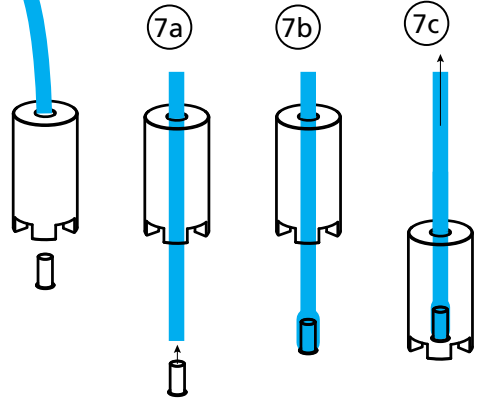

REPAIR OF BLOWER MOTOR CONNECTION BLOCK

The black motor connection block is not available as a service part. Below is a description of how to repair it. First check if the motor is still OK.

Main coil: 33 Ω . Between Black and Blue
 Start coil: 45 Ω . Between Brown and Blue
 Both coils: 78 Ω . Between Black and Brown

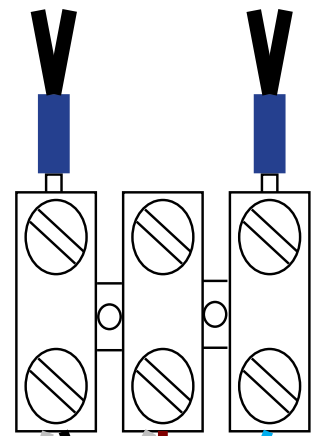
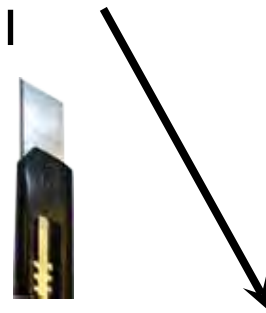
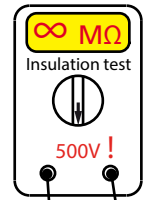

- Disconnect all wires from the motor connection block.
- Cut 3 terminals from the plastic terminal block.
- Connect all wires according to the diagram.

- Débranchez tous les câbles du bloc de raccordement du moteur.
- Couper trois bornes du bloc de connexion en plastique.
- Connecter tous les câbles selon le schéma.

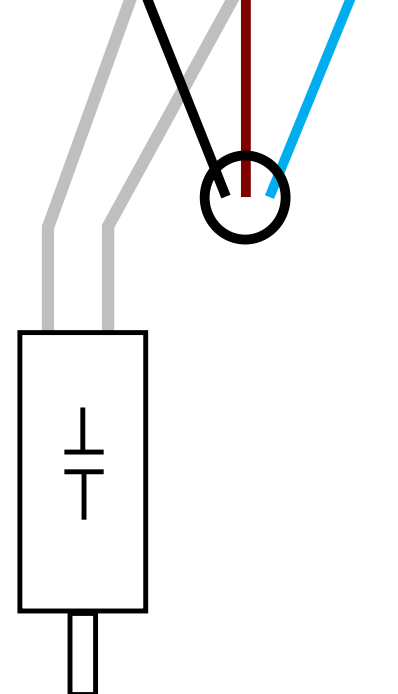

CONVERSION TO NEW MOTOR CONNECTION BLOCK

In case the new blower has this connection block, then see below how to connect.

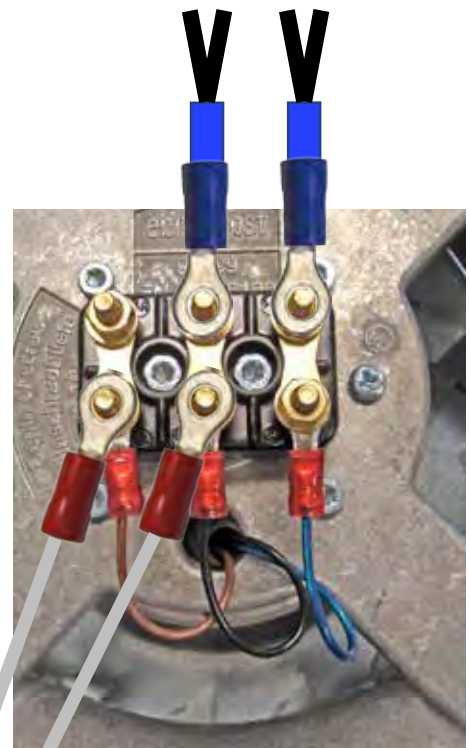

- Cut the receptacles from the capacitor and mount ringterminals instead.
- Pinch the ferrules and connect ringterminals to them OR cut the ferrules from the (black) wires, strip and mount ringterminals.
- Connect all wires according the overview.

- Couper les cosse femelle du condensateur et monter anneau terminals.
- Pincez les embouts et connecter anneau terminals à eux ou couper les embouts de l'(noir) câbles, dépouiller et monter anneau terminals
- Connecter tous les câbles selon le schéma.

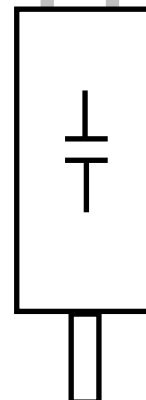

CONVERSION TO LEFT CONTROLS

This guide is meant to give an impression how to convert to left hand controls.
 Note that it is NOT possible to have the left door with the hinge on the right hand side!!

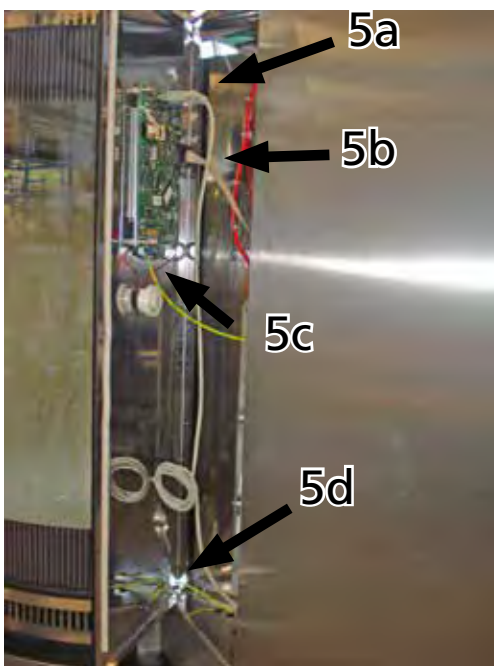
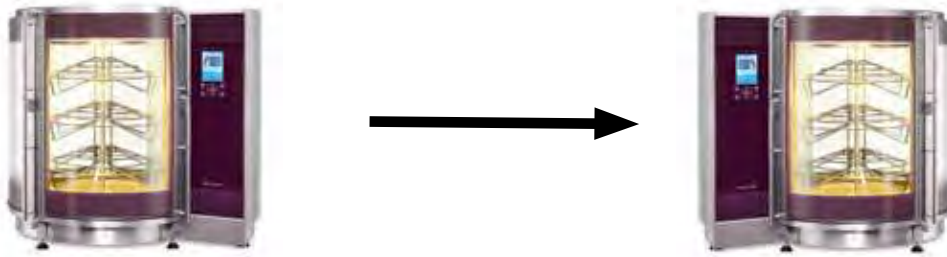

Description

1. Disconnect the mains supply!
2. Open the 2 backpanels with (4 screws in the middle)
3. Unscrew the screw at the top and loosen the bolt at the bottom, pointed with the two arrows.
4. Turn open the control panel.
5. Disconnect:
 - a) The RS232 / USB cable.
 - b) The ribbon cable.
 - c) The earth wire on the edge of the pcb.
 - d) The earth wire at the bottom of the panel.
6. Unscrew the other screw at the top, take out the control panel and lay it on a clean table.
7. Follow the same procedure to dismantle the left hand side (name) panel, take it out and lay it on a clean table.
8. Move the foam gasket on both panels to the other side or place new ones.

A foam gasket is mounted with sealant on both panels. This gasket will be on the wrong side when the panels are being interchanged. It is difficult to cut the gasket loose and therefore



it is recommended to place new ones. Part nr. 9110260 (2x 1mtr).

1. Mount the name panel on the right hand side.
2. Hook in the control panel on the left side and fix it with the front side top screw.
3. Lead the RS232 cable and the ribbon cable to the left side and connect them to the pcb.
4. Extend both earth wires or take longer new ones and connect them to the pcb and the control panel.
5. Close the panel and fix it.

The below is not necessary!

6. Move the emergency switch to the left side according to the procedure below.

It is difficult to do this for the first time because it is not possible to see the mounting nut and the lever of the adapter to release the adapter with the switches from the knob. See pictures.

7. Push up the lever and pull the adapter with the switches.
8. Loosen the mounting nut and take out the knob.
9. Drill out the 2 rivets from the type plate.
10. Mount the type plate on the right hand side.
11. Mount the knob on the left side.
12. Click the adapter with the switches on the knob.

Necessary parts.

9079140 3 mtr earth wire 2,5²mm.

2005763 3x ring terminal (for crimping on the earth wire)

9110260 2 mtr foam gasket.

9009213 2 rivets 2,5mm

[9291017](#) USB extension cable



SERVICE KIT 9190171, DOORGASKET CHANNEL REPAIR

The top and bottom doorgasket channel is build up by two horizontal sheet metal plates and a 10mm sheet metal spacer. The spacer plate has 5 cams on top and bottom side which are stuck through the horizontal plates. On these places, (marked C) the three plates are welded together. See the detailed views A-A and B-B.

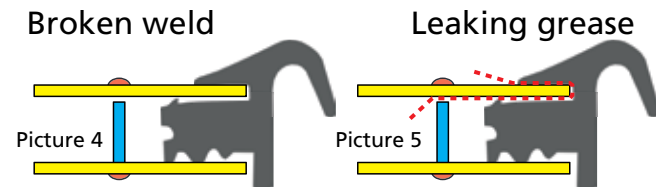
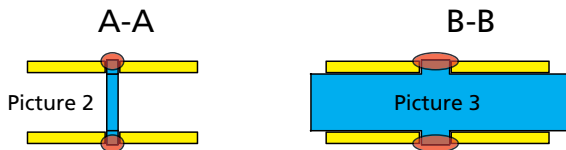
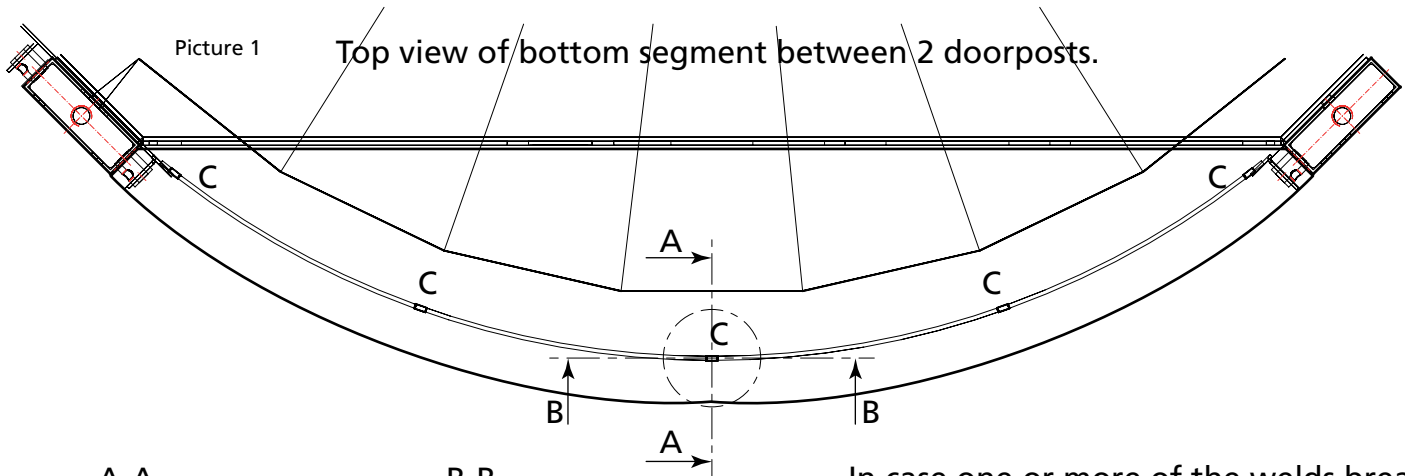

Drill and countersink a hole

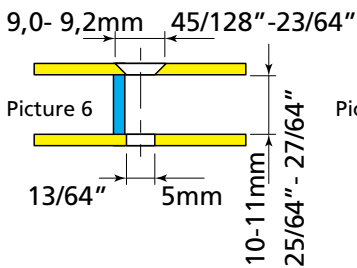

Repaired rabbet

Note bolt position

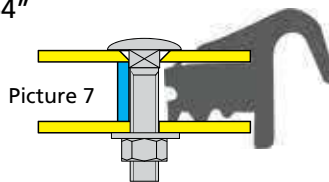

In case one or more of the welds break, the channel becomes wider and grease and steam will leak out of the cooking chamber.

In these cases, the grease will run behind the curved panel on which the lower drip tray is mounted.

Repairing this is done by drilling a 5mm hole just in front of the vertical spacer plate, countersink it and clamp it together with an M5 carriage bolt. To get it gastight, an o-ring is supplied.

For this purpose, a repair kit with drilling template is available under number [9190171](#).

Refer to page 4 for the contents of the repair kit.

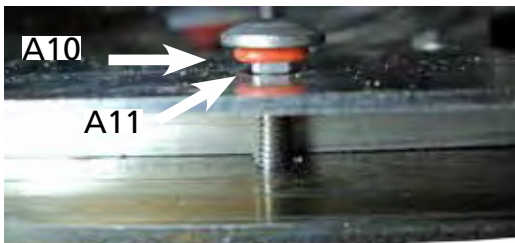
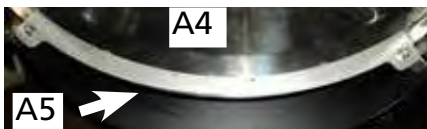

Step by step description of bottom channel repair:

1. Remove the curved panel with the drip tray.
2. Remove the doorgasket at the bottom side. Remove the gasket completely when it is worn out.
3. Attach 2 carriage bolts with an M8 nut and an M5 nut to the template. The M8 nut is used as spacer.
4. Mount the assembly on the bottom plate.
5. Make sure that the outline of the template falls within the outline of the bottom plate.
6. Drill 4 holes with the short 3,2 mm drill. Drill through the first plate only. Use the cutting grease to cool the drill!
7. Remove the template.
8. Drill all holes up with the 5 mm drill and now through the second plate too. Try to drill as straight (90°) as possible with 500 rpm maximum! Use cutting grease!
9. Countersink the holes till an outside diameter of 9 mm minimum and maximum 9,2 mm (45/128"-23/64"). See picture on previous page.
10. Place an o-ring under each bolt head.
11. Place the bolts in the holes and position the square under the bolt head, parallel to the spacer plate.
12. Place an M5 nut and washer and hold the bolt against rotating with (grip) pliers.
13. Tighten the nut $\pm 6\text{Nm}$ (4,5 Lbf.ft) with an 8mm wrench. Too tight will result in deformation of the bottom plate!!
14. The square under the bolt head will be pulled through the countersunk hole.
15. Put in the gasket. See description below.
16. Put back the curved panel with the drip tray.

Note that the repair of the top rabbet is the same as the bottom rabbet. In this case the curved panel at the top has to be removed, the door gasket at the top too and so on.

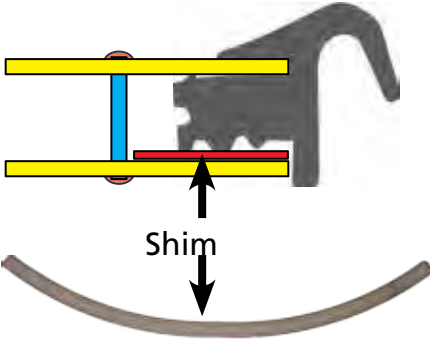
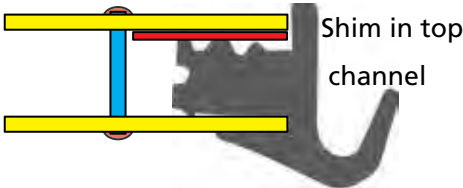

Example of top repair



Example of broken weld



General

When one of the bottom welds is broken, it is advised to drill all 4 holes from the template like in the above description. Consider to do this for all 3 doors at the same time.

When one of the top welds is broken, you could decide to fix only this weld by mounting a bolt on both sides of the weld.

The template has a laserline, which can be used to drill holes on any point of choice.

In case the weld is not broken, but the channel is too wide, a shim is available. A good channel is between 10mm, and an absolute maximum of 11mm (25/64"-27/64").

Place the shim at the bottom side in case of bottom repair and place it at the top side in case it concerns the channel at the top. This is because the gasket has to be pushed towards the cooking cavity. Put silicon between the shim and the plate. The next time that the gasket has to be replaced, the shim will then stay on its place.

Putting in a new doorgasket.

It is recommended to spray a mild soap mixed with water on the gasket before pushing it in the channel. The gasket is then better capable to settle itself and it makes the work easier.

When the gasket is mounted, also spray the outside of the gasket with the soap solution before closing the door. Check if the gasket is not folded when the door is closed. Specially when the gasket has this shape which is used until serial number 100033430!

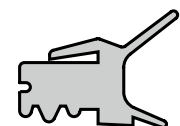

SERVICE KIT 9190173, MOUNTING SS GUTTERS

Due to limitations in the production proces of punching curved stainless steel, the mounting holes in the new stainless steel gutter differ from the plastic ones.

Therefore an upgrade kit is available to be able to mount this gutter on the "old" curved panels. For contents, see last page of this chapter.

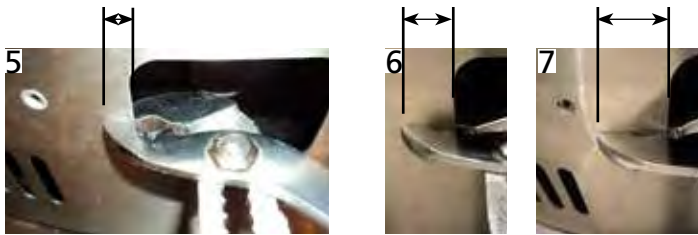

Close-up hinge side



Clearance



Mounting instructions with upgrade kit.

1. Remove 4 screws M5x16. (philips 2)
2. Mount the template with the same 4 screws.
3. Drill 4 holes with the 4mm drill.
4. Remove the template.
5. Carefully bend the curved panel inwards on both sides of the square hole.
6. Do this with waterpumppliers in three steps as shown.
7. See picture (5-7). *This is necessary to get some clearance on both sides of the gutter outlet. See detail 13.*
8. Mount the new gutter with the self tapping screws. (philips 2) Or (preferred) reuse the M5x15 screws. In that case, an M5 tap is necessary.
9. Slide the gutter as far as possible towards the hinge and tighten the screws. see detail 12. Leave a small clearance.
10. Mount 3 screws M5x16 in the remaining holes, only in case these are not used at #8
11. If necessary, pull the drainhose on the gutter outlet with snipe nose pliers.

Repeat this for all 3 doors.

In case it is preferred to mount the gutters on new adapted curved panels, these can be ordered with the part numbers, mentioned below. Note that the middle door has no grids in the curved panel and has therefore a different part number.



Exchanging plastic gutters, complete with curved panels.

1. Remove the 4 plastic finishing plugs. *It is almost impossible to get them out in one piece. Therefore, the easiest way is to carefully tick them inwards with a slotted screwdriver as shown on the picture.*
2. Unscrew the 4 screws (M5x45) behind the finishing plugs.
3. Take out the complete panel/gutter assembly.
4. Unscrew the M5x12 screws for reuse, and dispose the gutters and panels according local legislations.
5. Mount the new panel with the M5x45 screws with help of the nylon spacers.
6. Mount the gutter with the M5x12 screws. If necessary, pull the drainhose on the gutter outlet with snipe nose pliers.
7. Finish the holes with the finishing plugs.
8. Repeat this for all 3 doors.

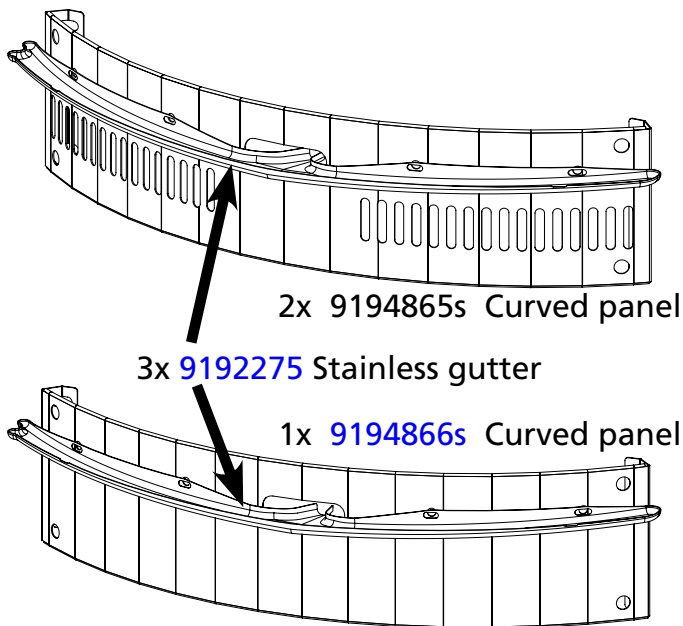

12x [2005250](#) Finishing plug



Related parts that can be reused.

12x [4288232](#) Screw M5x12

12x [4280218](#) Screw M5x45

12x [9057347](#) Spacer 10mm, nylon
 $\varnothing 5 \times \varnothing 10 \text{mm}$

Contents of service kit **9190173**

The kit consists of :

1x 9194890 Drilling template.

1x 9191301 drill 4,0 mm

12x Self tapping pan head screw A4 4,8x13mm
(borstlap 55660 048.013)

1x This instruction sheet



Necessary tools:

(cordless) drill.

Normal set of tools in which:

Waterpump pliers

Screwdriver Philips nr2

Screwdriver slotted

Snipe nose pliers

M5 tap in case the old screws are being reused.

GENERAL DESCRIPTION

Picture 1



Picture 2
Flow overview condenser unit

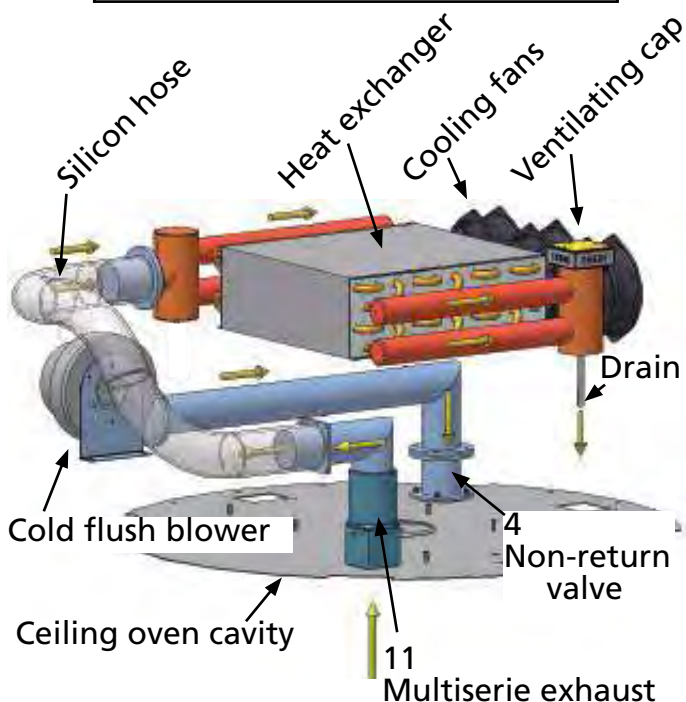

The **Multiserie Internal Condenser** is factory placed on top of the Multiserie. See the part above the dashed line.

A "drawer" construction is made to make access for service easier.

The condenser has 3 blowers to cool down the heat exchanger (condenser). These blowers turn on together with the blowers on the heaters.

The condenser has one blower to force the fumes out of the the oven (coldflush). It blows cool air into the oven at point 4 (see below). Fumes are forced out at point 11 and through a hose into the condenser. The condensed fluid coming out of the condenser, goes down through a 22mm copper pipe, followed by a grey hose. This hose must be hooked into the (customers) drainpipe. The blower is separately controlled by the oven controller.

Software description.

The "coldflush blower" is activated 25 seconds before the end of each cooking program. This time is determined in the service parameters. During this time the fumes will be forced out of the unit. When the door is opened after the "end" beep, almost no fume comes out anymore.

The **exhaust valve** is not programmable in the cooking program when an internal condenser is installed. The operation of it, is fixed in the software. During cooking it will be opened and during cleaning it will be closed.

Picture 3
Flow overview air inlet and outlet

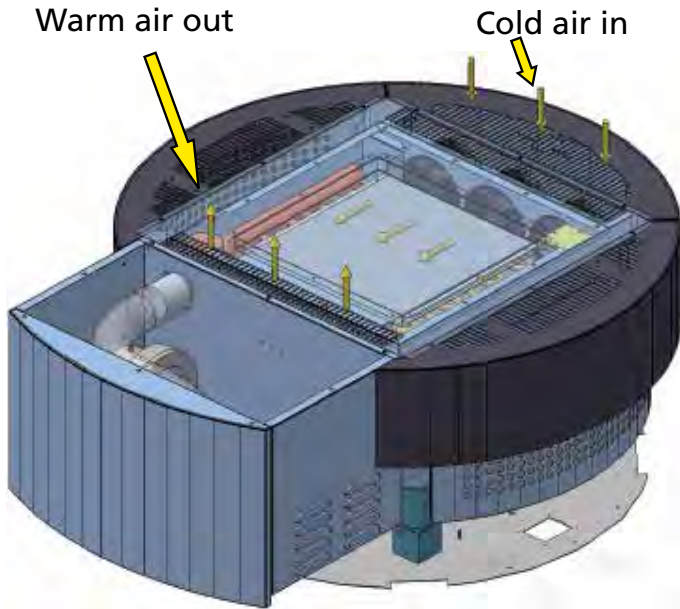

The **coldflush blower** can also be programmed in the cooking program. In the last column of the programming diagram, a certain time can be given during which the cold flush blower will be activated. This time is from 0 until 240 seconds and comes at the **beginning** of a cooking stage. For each "flush" a cooking stage need to be programmed.

Picture 3 gives an overview of the air grids which must be **prevented from blockage!**

Picture 4 shows all parts in the top of the Multiserie when the Internal Condenser would have been removed completely.

1. Tube connection from watersprayers.
2. Wire from one of the doorswitches.
3. Position of the PT1000 sensor in the top.
The other 2 wires are from one of the 3 halogen lamps.
4. Vent. (Fumes outlet)
5. Steam injection pipes and couplings.
6. Chain stretcher.
7. Soap mister. (soap tube is marked with black tape).
8. Rotor shaft with position switch and sliding ring/contacts for core probe.
9. 2 ceramic terminal blocks for serial connections of the door switches.
10. Position where the wires from the lower PT1000 sensor go into the post.
11. Non-return valve.

Picture 4

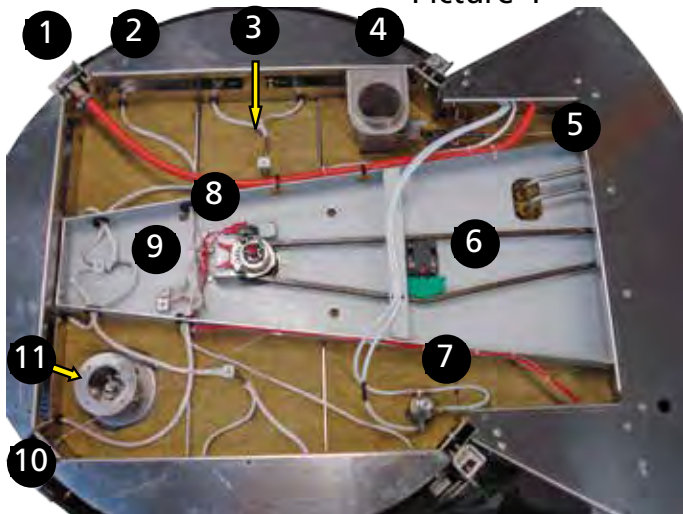

ACCESS TO SERVICE PARTS

Picture 5

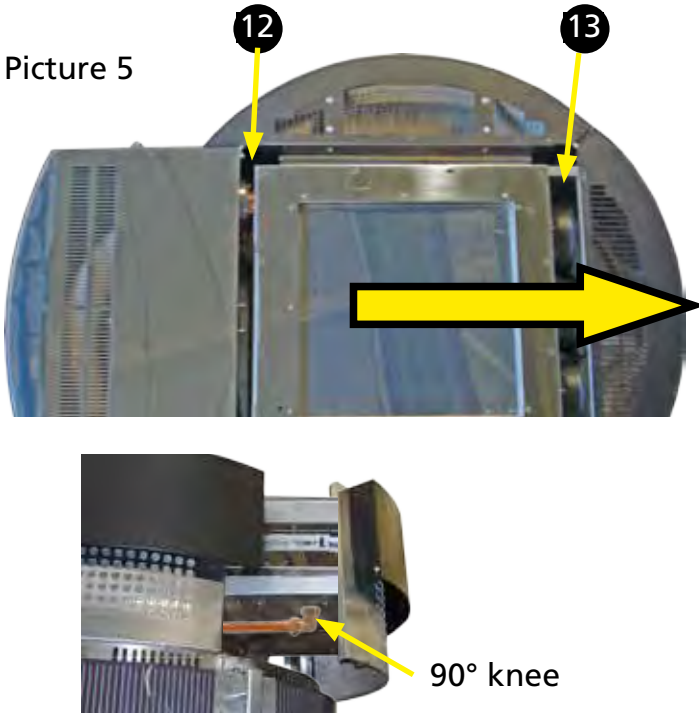

Service access to the previous mentioned parts.

Remove 12 screws and take away the top plate of the condenser. Slide out the Condenser Until the 90° knee can be reached and disconnect this. Now slide out the condenser completely. It might be necessary to put some extra force on the point marked with "12". **The condenser pipe has to slide out of the corresponding bush and the O-ring might stick.**

In case the "cold flush" blower needs service, than also remove the back side top plate. see picture 6.

Picture 6

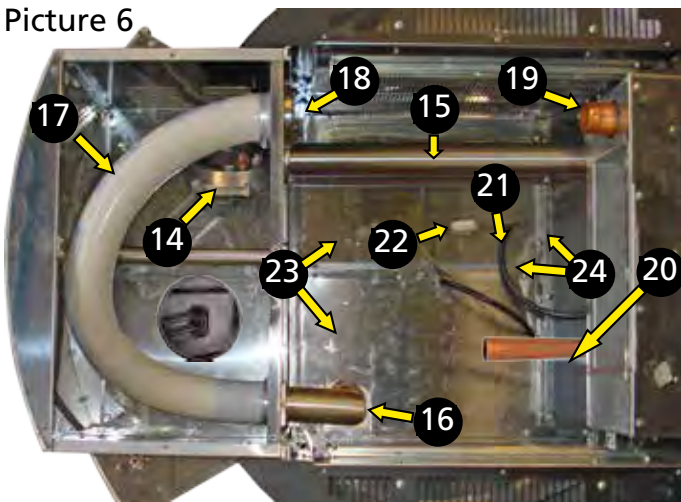

The following parts can be recognized:

- 14. Cold flush blower.
- 15. Connecting pipe to previous mentioned non-return valve (oven inlet).
- 16. Connecting pipe on exhaust oven.
- 17. Connecting hose, silicon.
- 18. Sliding bush.
- 19. Vapour inlet condenser.
- 20. Condensate drain tube.
- 21. Electric wire for the 3 heat exchanger blowers.
- 22. Junction connector in wire 21.
- 23. Top covers for oven. 4pcs total.
- 24. Construction beam (2x) for top covers.

Picture 7 taken from the left side

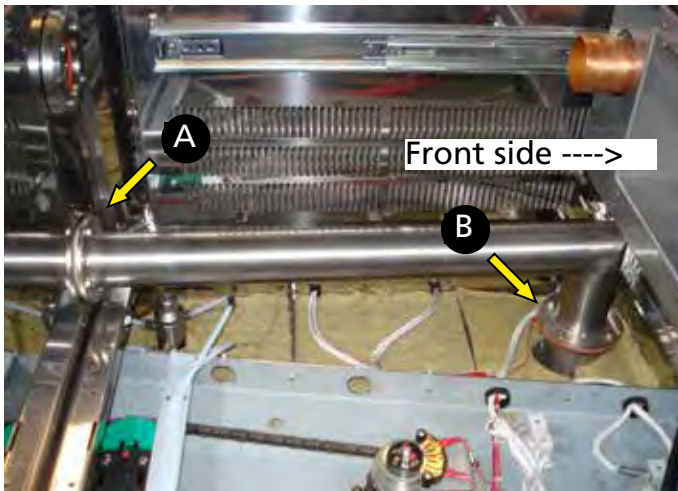

Removing the top covers.

After unscrewing, the top covers can be removed. The beams can simply be taken out. The two front covers have to be unscrewed from the frontside, underneath the condenser.

Now there is a clear view on most parts. See picture 7 and 8.

Picture 8 taken from the right hand side

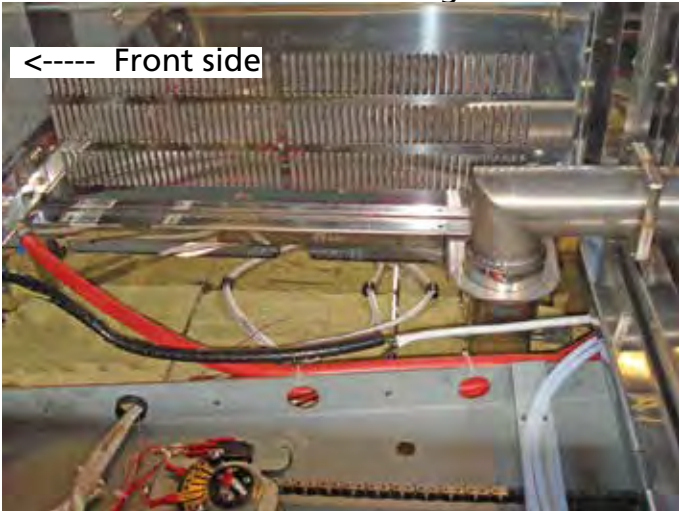

Picture 9 view into the backside



Picture 10 Crawfoot



Access to the steam injection couplings (position 5 in "general description").

These two couplings are positioned below the back side of the condenser hood. See picture 9. The bottom of the hood has a round opening (\varnothing 160) through which the couplings can be reached. A "crawfoot", the tool shown in picture 10 is the most convenient tool to service these couplings. You need the nr.17 for the swivel and nr.19 for the mounting nut.

It is possible to remove the curved back plate in case this is more convenient.

Up to serial number 100048173, the bottom is not provided with this round opening. In this case the complete condenser hood has to be removed after removing the condenser as explained in the next pages.

EXCHANGING PARTS

Picture 11

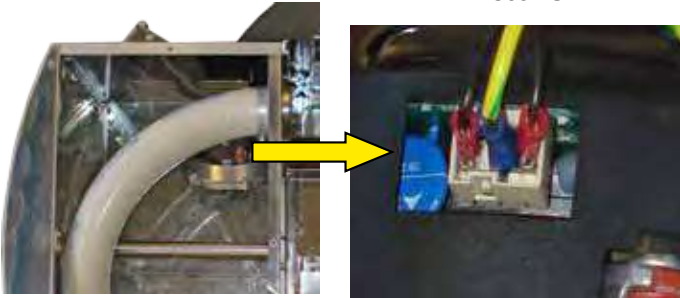

Exchanging the cold flush blower and / or the non-return valve (housing).

- Disconnect the wires from the blower. See picture 11. The middle connection is earth. The two black wires can be exchanged. *(Note that the US version has a 3-pole plug with the earth connection on pin 3, the right hand side)*
- Unscrew the 4 bolts from the flange. Picture 12 mark "A"
- Take out the blower.
- Unscrew 4 bolts (marked B) on the valve flange.
- Remove the connecting pipe.
- Unscrew the non-return valve and take it out. (4 Nuts marked C on picture 13)
- Reverse the procedure to install.

Picture 12

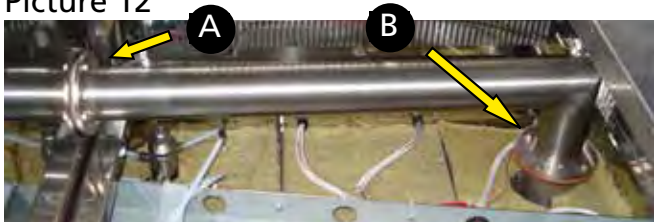

Picture 13



Exchanging the silicon gasket in the non-return valve.

- Pull down the valve and clamp it with a pair of (grip) pliers. Unscrew the 4 screws and take out the gasket.
- Reverse the procedure to install.

Picture 14



Exchanging the heat exchanger.

- Remove the cover from the condenser. Picture 15.
- Disconnect the 2 red tubes from the bottom side of the condenser.
- Remove the ventilating cap. (mark D). *The shape can differ in some revisions.*
- Lift out the heat exchanger.
- Reverse the procedure to install.

Picture 15

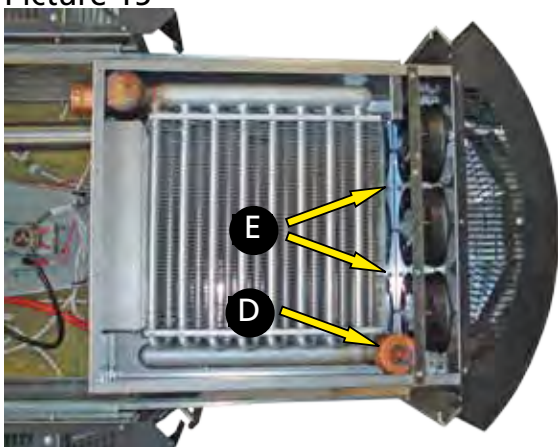

Exchanging the 3 cooling blowers.

- Disconnect the wiring for the blowers at the bottom side of the condenser.

Picture 16

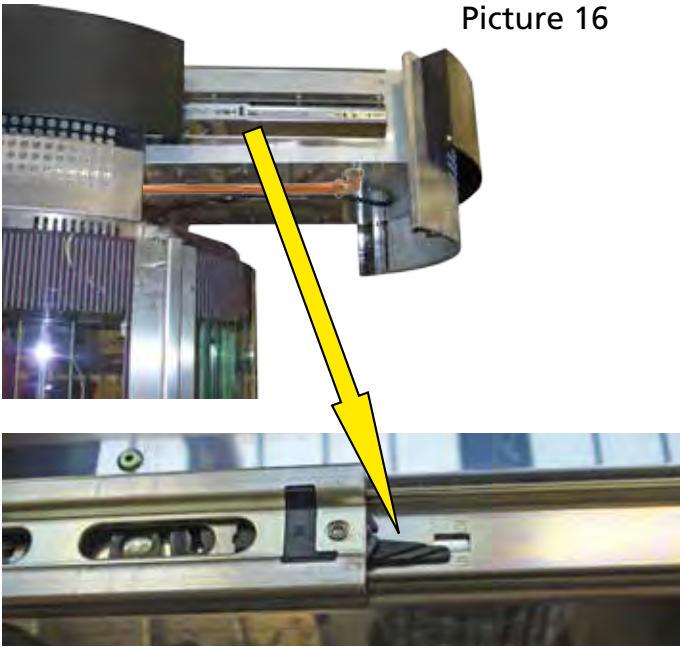

- Unscrew the blower mounting bracket (mark E) from the bottom side of the condenser.
- Take out the bracket with the blowers.
- Reverse the procedure to install.

Taking out the complete condenser.

In case it is convenient for some reason to take out the complete condenser unit, than follow the instruction below. **Do this with at least 2 persons!!! Weight 40kg.**

- Disconnect all tubes and wiring to and from the "moving" part.
- Pull out the condenser as far as possible.
- Picture 16.
- Push the lever on the guide in the direction as pointed on the guides and pull out the condenser a few centimeters.
- Slide out the condenser **with at least 2 persons!!! Weight 40 kg, 88Lbs!**

Picture 17 Condenser removed



Putting the condenser back in.

- Slide the guides as far as possible in the unit.
- Lift up the condenser, carefully position the guides and slide them in. Take care of the tubes and wires and slide in the condenser at least until you hear both guides clicking, meaning that they are locked.
- **Slide out again and check the locking!!!!**



TROUBLE SHOOTING HOOD

Symptom	Possible cause	Solution
Fumes coming out of the condenser hood	Leaking O-rings	Check and or replace the O-rings (pos. 71 and 79)
	Leaking silicon hose (pos 74)	Fasten the hose clamps.
		Replace the hose in case it is broken
	One or more axial flow ventilators stopped	Check voltage and wiring.
		Replace ventilator if broken
	Air grids at the top blocked. See "general description"	Clean or remove obstacles from grids.
External pollution of the heat exchanger	Clean the heat exchanger	
A large amount of fumes comes out of the oven when opening the door at the end of the cooking program.	The radial flow ventilator does not function	Check the parameter "cold flush" in the service menu. It should be adjusted at 25 sec
		Check the software version. Program the right version. Version 3.91 or higher.
		Check the wiring.
		Check the voltage on the ventilator.
		Replace ventilator if defect
	The non return valve is blocked. (see point 11 in "general description")	Clean the valve.
		Replace the silicon gasket if it is sticking.
		Lubricate with "food grade" silicon spray.
	The exhaust valve is blocked. (see position 4 in the "general description")	Clean the exhaust valve
	Blockage of the condens hoses	Clean or replace the drain hoses
Clean the drain hose connection nipples		
Internal blockage of the heat exchanger	Replace the heat exchanger	
Water drips down from the inside of the hood	The condenser coil might be at the end of its life time.	Replace the condenser coil
	Drain pipe or hose not connected or broken.	Check the drain pipe and hose

Error message	Description	Possible causes
..... sensor open (in general)	The temperature sensor input reads higher than 320°C (600°F). In resistance, this is higher than 2200Ω.	
.....sensor shorted (in general)	The temperature sensor input reads lower than 0°C (32°F). In resistance, this is lower than 1000Ω.	
Top sensor open		Top sensor broken or wiring loose
Btm sensor open		Bottom sensor broken or wiring loose.
Core sensor open		Core sensor broken or wiring loose.
Top sensor shorted		Top sensor broken or wiring shorted
Btm sensor shorted		Bottom sensor broken or wiring shorted
Core sensor shorted		Core sensor broken or wiring shorted.
Powerboard fails (See next chapter)	Communication problem between the Power & I/O board and the CPU board	Broken Power & I/O board or connection problem in ribbon cable (connector).
Slave board fails (See next chapter)	Communication problem between the Extension I/O board and the CPU board. (Multiserie and ACR)	Broken I/O extension board or connection problem in ribbon cable (connector). See next chapter
Air valve defect Disabled in s.w. version 4.30 for old CPU board !! Enabled in V5.00.10 of new CPU board. Disabled again in s.w. version V6.00.10	Missing feedback signal from one or both microswitches on the air valve (vent).	Position switch(es) loose. Position switch(es) defect. Position switch(es) wrong adjusted. Camshaft loose (does not rotate). Airvalve motor broken. Airvalve blocked. Loose wiring of switches or motor. Both switches are activated.
Water drain defect	Missing feedback signal for the cleaning position of the 3-way valve	Broken switches inside the valve housing. Broken or loose relay K8. Wiring problem
Grease drain defect	Missing feedback signal for the cooking position of the 3-way valve	Broken switches inside the valve housing. Broken or loose relay K7. Wiring problem
Fan guard fails Diabled in s.w. version V5.01.03 !!	Too less or no heat distribution to the cooking cavity	The blower is not rotating while it should. Defect vane switch(es). broken heating elements

Other messages	Description	Possible causes
Please clean first	The cleaning program did not finish. Detergent remainings could be in the oven cavity. Start the cleaning program (in rinse)	The cleaning program has been stopped by the operator. The cleaning program has been interrupted by a power supply failure, or the power supply has been switched off during the cleaning program (at night).

COMMUNICATION BETWEEN THE ELECTRONIC BOARDS

1. All boards are connected to each other with a ribbon cable.
2. The CPU board communicates by means of a serial protocol with the other boards.
3. Therefore you will see 2 LEDs, named RXD and TXD, flashing (in high frequency) close to the sockets.
4. In case the LED's on a board flash differently from the other boards, this board might have a communication problem.
5. The power for the CPU board is also provided through the ribbon cable. The initial source is the Power&I/O board.

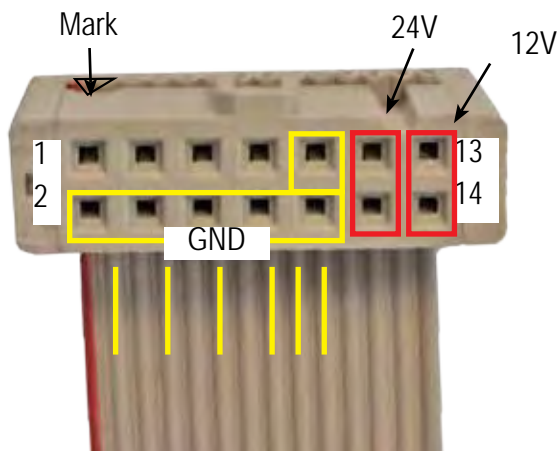
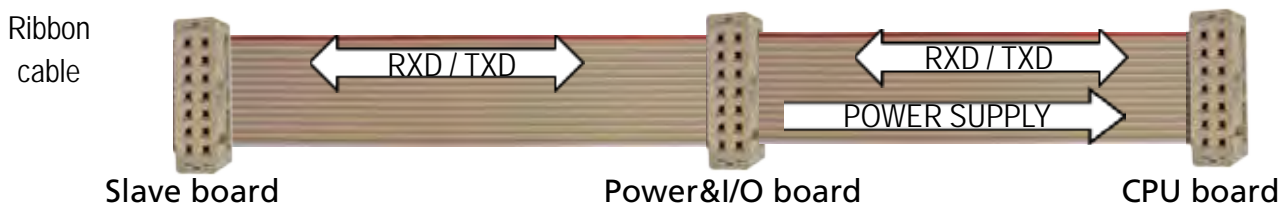

Schematic overview

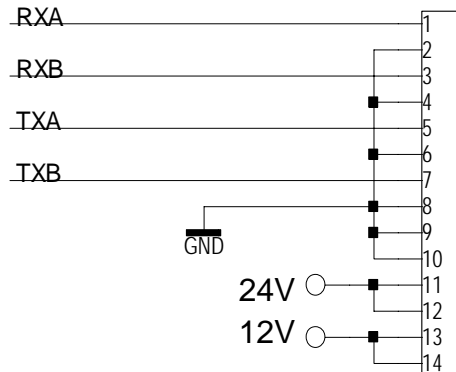

LED Positions on the boards

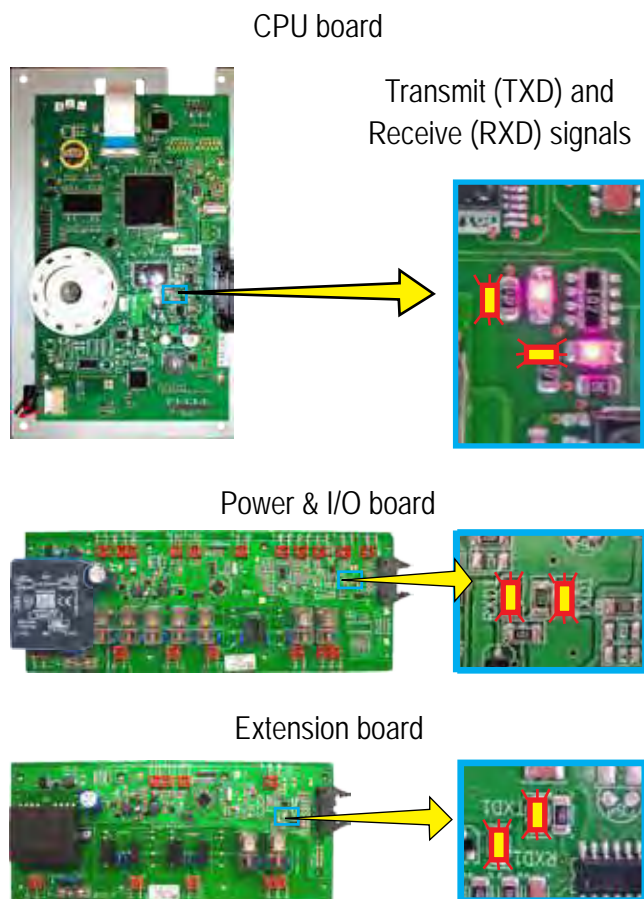

TROUBLESHOOTING BY SYMPTOM

Symptom	Possible cause	Caused by	
Product not cooked, cooking takes more time	Air circulation problem	Fanblade loose	
		Blower(s) defect	
		Capacitor defect	
		Transformer defect	
		Control defect	
		Filters blocked	
	Short of heat	Heating element defect	
		Contactora defect	
		Vane switch defect	
		Control defect	
		Sensor defect	
		Wire loose	
	Program ends too soon	Core probe defect	
Core probe still hot when starting program			
Sliding contact on rotor dirty or defect.			
Cooking program wrong	Wrong programming		
	Wrong product		
Bad cooking results, uneven cooking	No rotation	Chain broken or derailed	
		Motor defect	
		Capacitor defect	
		Control defect	
		Bearing defect	
		Rotor support comes loose	
	Too much heat	Contactora hangs	
		Sensor defect (shortened)	
	Too much steam	Watervalve defect	
		Dirt in watervalve	
	No or too little steam	Dirt in watervalve	
		Waterpressure too low	
		Tubes calcified	
		Leaking hose	
		Control defect	
		No heating	
	Program does not reach the end	Core probe shortened	
		Wrong programming	

Symptom	Possible cause	Caused by
Rotation does not stop or stops in wrong position	Detector switch rotor defect	
	Reed contact door shortened	
	Control defect	
Bag overloaded	Watervalue defect (too much steam)	
	Too much steam in program	
Oven cavity fills up	Drain sieve clogged	Valve, relay or control defect
	Drain valve in wrong position	
	Tube clogged by fat from bag	
Sewage get clogged	Drain valve in wrong position	Valve, relay or control defect
Overflow bag	Drain valve in wrong position	Valve, relay or control defect
Less or no lighting	One or more lamps defect	
	Control defect	
	Calcifying or greasing of lamp glasses	
	Broken lamp gasket	
Bad cleaning result	No steam	See bad cooking due to no steam
		Water tap closed
		Filter clogged
	No rinse water	Valve defect
		Control defect
		Hose disconnected
		Water pressure too low (<2bar)
		Water tap closed
	No detergent	Compressor failure
		Nozzle defect
		Air leakage
		Fluid leakage
		Pressure reducer valve defect
Container incorrect connected		
Wrong detergent	Container empty	
Bad drying	Control defect	
Leakage of steam at the doors or drain	Door not right adjusted	
	Doorgasket damaged	
	Air exhaust valve clogged	
Deterioration of components, rubbers	Wrong detergent	
	Cleaning instructions neglected	
Drip drains clogged	Door not right adjusted	
	Doorgasket damaged	
	Cleaning instructions neglected	

Symptom	Possible cause	Caused by
Controls defect	Leakage of steam through ventilator shaft	
	Leakage of steam through heating element	
	Cooling air flow blocked	
	Fuses blown	

TROUBLESHOOTING BY PART / FUNCTION

Description of part	Symptoms	Possible cause	Action
Control defect	Key board fails. No display. Display shows strange things. Outputs fail. Inputs fail.	Loose flatcable. Broken part.	Check keyboard and I/O boards. See I/O test in service menu.
		Fuses blown	Check fuses
		Relais defect	Check relay
		Wrong software or loss of data.	Check software version or upload latest software
		Parameters not on right settings.	Check parameters
		Steam leakage	Check sealing of shaft and heating elements.
		Transformer output voltage too high.	Check transformer.
		Temperature too high.	Check cooling air flow. Clean grids.
Security thermostat	The unit will not start up	Problem with ventilators. (rotate too slow) Malfunction of vane switches. Sticking contact(s) of contactor(s). Broken thermostat.	Check these items.
Steam leakage	Controller not stable. Programs act strange. Controller switches off during program. Visibility of LCD gets worse.	Leakage of steam through ventilator shaft. Leakage of steam through gasket of heating element	Check sealings of these items. (remove ventilator plate pos 117 and the fanblade of the blower)
Cooling air flow	Controller overheated	Cooling air flow blocked.	Clean air grids.
Relay for compressor, water filter etc.	The output is not switching on	Broken contact	Replace relay
	The output is not switching off	Contact sticks, relay hangs	Replace relay
Transformer defect	Unable to switch ON the Multiserie.	Internal short circuit in transformer (gets hot). Fuse F1 and/or F2 blown	Check and replace transformer if necessary.

Description of part	Symptoms	Possible cause	Action
Heating element	Mutisserie does not reach the adjusted temperature. Product not ready in time. Uneven cooking	Heating element defect Wire loose	Check heating element and wiring. Replace if necessary.
Contactor	Product overcooked Uneven cooking Cooking takes more time Product not ready in time	Contactor hangs (contacts stick together) Contacts do not make contact Contactor does not function Controller problem.	Check contactor. Check controller (output test)
Blower	Cooking takes more time Bad cooking result Uneven cooking Vibrating and/or squeaking noise. Blower rotates too slow.	Blower shaft stuck by dirt or broken shaft sealing. Blower(s) defect. Capacitor defect Wiring or controller problem. Transformer broken or wrong connected.	Fix fanblade Check adjustment. Check blower shaft. Check coil resistance. Check coil insulation. Check bearing Check adjustment. Check capacitor Check transformer.
Vane switch	Product not ready in time. Heating elements do not switch on.	Micro switch stays open. Wiring loose. Wing of vane switch stuck. Blower rotates too slow.	Remove dirt and/or obstacles from wing. Check wiring and microswitch. Check voltage on ventilator.
	Security thermostat switched off. Fire behind ventilator plate.	Wing of vane switch stuck. Microswitch stays closed.	
Rotor	Rotor does not rotate	Motor defect. Chain broken or derailed. Bearing defect. Capacitor defect. Rotor support comes loose.	Check these items.
Rotor switch	Rotor does not stop, or does not stop in right position.	Detector switch rotor defect	Replace (opto)switch
		Positioning disc displaced	Check adjustment and fix it.
Core sensor	Baking program never ends and product overcooked.	Core Sensor defect (resistance too low)	Replace sensor if wiring is ok.
	Baking program ends too soon	Core sensor defect (resistance too high).	Replace sensor if wiring is ok.
		Customer starts program while core sensor is still hot.	Give instructions how to use.

Description of part	Symptoms	Possible cause	Action
Sensor	Temperature read-out on LCD is not stable.	Upper sensor defect. Wire loose.	Check sensor and wiring. See also input test in service menu
	Product over cooked. Cooking takes more time. Uneven cooking.	Upper or lower sensor defect. (resistance too low)	Check sensor and wiring. See also input test in service menu
	Cooking takes more time	Upper or lower sensor defect. (resistance too high).	Check sensor and wiring. See also input test in service menu
	Uneven cooking (difference between lower and higher racks)	Upper or lower sensor defect. Offset parameter not right adjusted. See service menu.	Check sensor and wiring. See also input test and parameters in service menu.
Sliding contact (on rotor)	Baking program ends too soon	Bad or no contact (resistance too high).	Clean contact or replace.
Illumination	Less display effect	One or more lamps defect Calcifying or greasing of lamp glasses Broken lamp gasket	Replace lamps. Clean or replace lamp glasses. Replace gasket
Air exhaust valve (Vent)	Steam blows along the doorgaskets. Trumpet sound when closing the door Whistle sound at the exhaust Product too wet Product too dry	Air exhaust valve clogged Air Exhaust valve malfunction	Check and or clean exhaust pipe and valve Check valve motor Check position switches on valve motor
Watervalue	Product too dry. Product too wet. Product not well proofed. (Bake version). Cleaning not ok.	Watervalue coil defect. Filter clogged. Dirt in watervalue. Reducer in watervalue clogged. Reducer in watervalue not well mounted.	Check coil. Clean valve if possible. Replace valve AND reducer.
Water supply	Product too dry. Product not well proofed. (Bake version). Cleaning not ok.	Water tap closed. Water pressure too low (<2bar). Filters blocked. Kink in hose.	Open tap. Check pressure. Check filters Search for a kink in the hose.
Tubes calcified	Product too dry. Product not well proofed. (Bake version)	Supply water not decalcified. Decalcifying equipment not ok. Decalcifying filter saturated.	Check water hardness. Change filter.
Door switch	Message door open appears while door is closed	Reed contact door shorted. Wiring shorted.	Check reed contact and/or wiring. Replace if necessary
	Blowers, heaters and rotor stay on while door is opened.	Reed contact defect. Wiring loose.	Check reed contact and/or wiring. Replace if necessary

Description of part	Symptoms	Possible cause	Action
Door	Door(s) are leaking.	Door not right adjusted	Adjust door.
	Door does not close smoothly	Door not right adjusted	Adjust door.
	Door lock not functioning	Doorlock broken or loose	Mount new parts and or fasten it.
	Broken glass of inside or outside door.	Slamming of door.	Give instruction to operator
		Fastenings bolts and nuts are loose.	Tighten all fastenings.
		No sealing ring between steel and glass.	Mount new glass with sealing rings between steel and glass.
Door gasket	Door(s) are leaking	Deterioration by (wrong) cleaning agent. Cleaning instructions neglected. Broken due to bumping, striking.	Give instructions
Compressor	Bad cleaning result	Compressor does not start or stops while power is on. Compressor does not give enough pressure. Controller problem.	Check power supply, capacitor, coil resistance, coil insulation. Check membrane and leakage of air hoses.
Pressure regulator	Bad cleaning result	Pressure regulator adjusted on too low pressure Pressure regulator defect	Replace and/or adjust pressure regulator
	Bottle with cleaning agent broken Too much use of cleaning agent	Pressure regulator adjusted on too high pressure Pressure regulator defect	Replace and/or adjust pressure regulator
Air controlled nozzle	Bad cleaning result	Nozzle leaks air. Nozzle does not open Nozzle leaks fluid.	Check nozzle.
Cleaning	Cleaning not ok	No steam production. (no heat or no water). Air controlled valve stuck, clogged or broken. Compressor problem. Pressure reducer problem. Fluid leakage. Air leakage. Empty cleaning agent jug. Cleaning agent jug incorrect connected. Wrong cleaning agent. Rinse nozzle(s) clogged. Water pressure too low (> 2bar). Cleaning instructions neglected. Drain sieve clogged. Drain pipe clogged.	Check these items.

ELECTRICAL PARTS

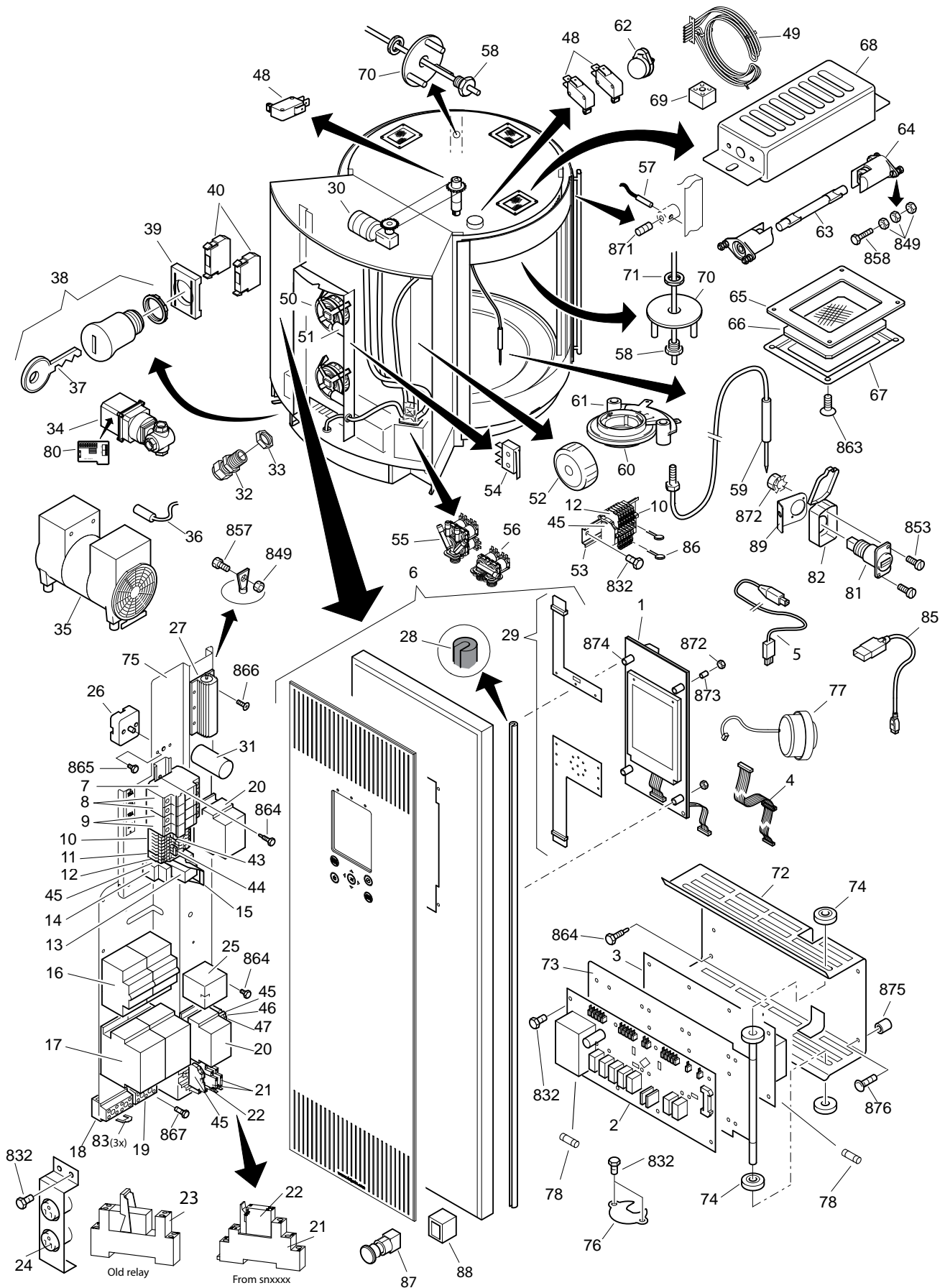

Pos	Part nr	Qty	Unit	Description
1	9172552s	1	Pcs	CPU + LCD + buzzer
2	9192202s	1	Pcs	Power & I/O board
3	9192203s	1	Pcs	Extension I/O board
4	9192204	1	Pcs	Ribboncable, control boards
5	9191101	1	Pcs	Extension cable RS232
6	9190129s		Pcs	Control panel, ass (purple) until sn100071948
6	9190206s	1	Pcs	Control panel, ass (black) from sn100071949
7	9191229	2	Pcs	Fuse holder
8	9191230	2	Pcs	Fuse FNQ-R-15A 3/8x1,5"
9	9191231	2	Pcs	Fuse FNQ-R-10A 3/8x1,5"
10	9191240	8	Pcs	Rail terminal, 4p grey
11	9191239	2	Pcs	Rail terminal, 4p green
12	9191223	1	Pcs	Endkap, railterminal
13	3701214	1	Pcs	Relay ABB CR-M230 AC4L
14	3701215	1	Pcs	Socket, relay CR-M
15	3701216	1	Pcs	Clamp, relay CR-M
16	9191206	2	Pcs	Automatic fuse 40 Amps.
17	9191207	2	Pcs	Contacto A26-40-00
18	9191204	1	Pcs	Connecting block, 1,2,3,4
19	9191205	1	Pcs	Connecting block, 5,6,7
20	3500069	2	Pcs	Contacto A9-40-00
21	9291140	2	Pcs	Relay Allen Bradley
22	9291141	2	Pcs	Socket, relay Allen Bradley
23	9290114		Pcs	Conversion kit, Allen Bradley relay
24	9191201	1	Pcs	Socket, 125V 2p
25	9191181	1	Pcs	Contacto B6-30-10
26	9191188	1	Pcs	Thermostat with reset, 360°C
27	9191242	1	Pcs	Resistor 22Ω, 150Watt
28	9110260	2	Mtr	Gasket, silicon Ø 8mm
29	9172329	1	Pcs	Keypad, set of 2
30	9190126	1	Pcs	Gearmotor with chain-wheel
31	9077101	1	Pcs	Capacitor 2,5 uF
32	9172420	1	Pcs	Cable gland M32
33	3701068	1	Pcs	Cable gland nut M32
34	9191092	1	Pcs	Valve, 3-way
35	9191202	1	Pcs	Compressor 20psi 115V 60Hz 91,5L/min
36	3500641	1	Pcs	Capacitor 16uF 450V
37	9111181	1	Pcs	Key, emergency switch
38	9111180	1	Pcs	Emergency switch + key
39	9111190	1	Pcs	Adapter, emergency switch
40	9111200	2	Pcs	Contact, emergency switch
43	9191238	1	Pcs	Connecting bridge 2p
44	9191237	1	Pcs	Connecting bridge 3p
45	9191222	2	Pcs	End clamp din rail
46	9191233	1	Pcs	Rail terminal, 2p green
47	9191232	3	Pcs	Rail terminal, 2p grey
48	3500109	3	Pcs	End switch

Pos	Part nr	Qty	Unit	Description
49	9192091		Pcs	Heater, 10kW 208V slim flange until sn100035862
49	9192254	1	Pcs	Heater, 10kW 208V wide flange from sn100035863
50	9192225s	2	Pcs	Blower
51	9192034	2	Pcs	Capacitor 6 uF
52	9192227	1	Pcs	Transformer, 208V-->208/165V
53	0166741	6	Pcs	Din rail
54	9191306	2	Pcs	End switch
55	9191200	1	Pcs	Valve, quadruple 110-127V60Hz
56	9191199	1	Pcs	Valve, double inlet 110-127V60Hz
57	3500020	3	Pcs	Reed switch
58	9192158	2	Pcs	Temperature sensor
59	9192005s	1	Pcs	Core temperature probe
60	9192018	1	Pcs	Sliding ring
61	9192019	1	Pcs	Sliding contact
62	9191198	1	Pcs	Gearmotor
63	9191196s	3	Pcs	Lamp, halogen 120V 150W
64	9052826	6	Pcs	Lamp holder, halotherm
65	3500040	3	Pcs	Seal, oven illumination
66	9192234	3	Pcs	Glass, oven illumination
67	9194485	3	Pcs	Cover profile, oven illumination
68	9194294	3	Pcs	Cover
69	9171110	6	Pcs	Terminal block, 2 pole porcelain
70	9194382	2	Pcs	Protection PT1000 sensor
71	3704133	1	Pcs	Nut 1/4"
72	9194397	1	Pcs	Mounting profile I/O boards
73	9190503	1	Pcs	Mounting plate I/O boards
74	9040918	4	Pcs	Nut with milled edge
75	9194399	1	Pcs	Mounting panel electric components
76	9194482	1	Pcs	Locking plate, strain relief
77	9172362	1	Pcs	Buzzer 12V
78	9171129	1	Pcs	Fuse 125mAT (5x20mm)
79	9111230	1	Pcs	Fuse 63mAT (5x20mm)
80	9191302			Pcb for 3-way valve (fused with 0,5A 5x20mm)
81	9291011	1	Pcs	USB adapter
82	9291010	1	Pcs	USB cover
83	9044580	3	Pcs	Jumper copper, G10/3
84	9191250	1	Pcs	End cap, fuse holder
85	9291017		Pcs	USB cable extension
86	9191308	2	Pcs	NTC 5 Ohm
87	9291002		Pcs	Rotorbutton
88	9291003		Pcs	Switch
8xx				See fasteners

Pos	Part nr	Qty	Unit	Description
101	9190102s		Pcs	Outer door complete, ass (purple) until sn100071948
101	9190208s	3	Pcs	Outer door complete, ass (black) from sn100071949
102	9190136s	3	Pcs	Inner door complete, ass
104	9190141s	3	Pcs	Hinge, doorhandle ass.
105	9172054	6	Pcs	Brass bearing 8 mm
106	9172122	6	Pcs	Brass bearing 8 mm, adjusted
108	9194411	3	Pcs	Hinge profile
109	3702341	12	Pcs	Collar bush 10x5x2,5
110	3702342	36	Pcs	Collar bush 10x5x3,5
111	9192003	3	Pcs	Glass, outer
112	9194405	3	Pcs	Finishing profile, hinge side
116	9192239	3	Pcs	Glass, inner
117	9190512	3	Pcs	Hinge profile, inner door
118	9194496	3	Pcs	Magnet holder
119	9070141	24	Pcs	Magnet block
120	9194116	3	Pcs	Filling profile, magnet holder
130	9190459	3	Pcs	Door handle, middle
131	9190458	3	Pcs	Lock construction profile
132	9191102	12	Pcs	Plastic bearing 8 mm
133	9194356	6	Pcs	Filling ring 15x10,3x1,5
134	9191085	8	Pcs	Plastic bearing 6 mm
135	9194357	6	Pcs	Filling ring 12x8,3x1,6
136	9193061	3	Pcs	Pin, 6mm
138	9194306	3	Pcs	Lever, top
139	9194307	3	Pcs	Lever, bottom
143	9171014	6	Pcs	Cap, pvc 30x15
144	9190460	3	Pcs	Door handle, bottom
145	9193059	12	Pcs	Spacer 39mm, Ø14x5,2
146	9190461	3	Pcs	Door handle, top
147	9194404	3	Pcs	Profile, door handle
148	9193051	3	Pcs	Latch rod, top
149	9194269	6	Pcs	Drive plate,latch rod
150	9193052	3	Pcs	Latch rod, bottom
153	9194406	3	Pcs	Finishing plate, door lock
154	9194822	3	Pcs	Bracket, doormagnet
155	9084077	5	Pcs	Magnet
160	9194204	1	Pcs	Hinge, left top
161	9194881	3	Pcs	Filling plate, left top
162	9190424	1	Pcs	Hinge, left bottom
163	9194880	3	Pcs	Filling plate, left bottom
164	9190494	2	Pcs	Hinge/catch, middle top
165	9194879	6	Pcs	Filling plate, middle top
166	9190495	2	Pcs	Hinge/catch, middle bottom

Pos	Part nr	Qty	Unit	Description
167	9194878	6	Pcs	Filling plate, middle bottom
168	9190496	1	Pcs	Catch, right top
169	9194883	3	Pcs	Filling plate, right top
170	9190497	1	Pcs	Catch, right bottom
171	9194882	3	Pcs	Filling plate, right bottom
172	9192240s	3	Pcs	Door gasket
172	9192160s	3	Pcs	Doorgasket untill ser nr 100033208
173	9192063	0	Pcs	Adjusting leg
174	9192042	3	Pcs	Hinge pin
175	9192155	3	Mtr	Finishing strip, rubber
176	9190513	3	Pcs	Drip tray, door SS
177	9190504	3	Pcs	Finishing strip, SS
181	9171132	6	Pcs	Plug
182	9191256	1	Pcs	Doorstop ball, 10mm SS
183	9193105	1	Pcs	Doorstop base plate
184	9194549	1	Pcs	Doorstop latch plate
186	9191274	6	Pcs	Plastic bearing 8mm
187	9192265	2	Pcs	Spacer 7mm, Ø16x8,5
188	9190040		Pcs	Doorhandle assembly complete
189	9191119	2	Pcs	Bracket clamping
190	9194354	1	Pcs	Bracket handle blocking
191	9190073			Handle blocking, ass
8xx				See fasteners

WATER AND STEAM SYSTEM

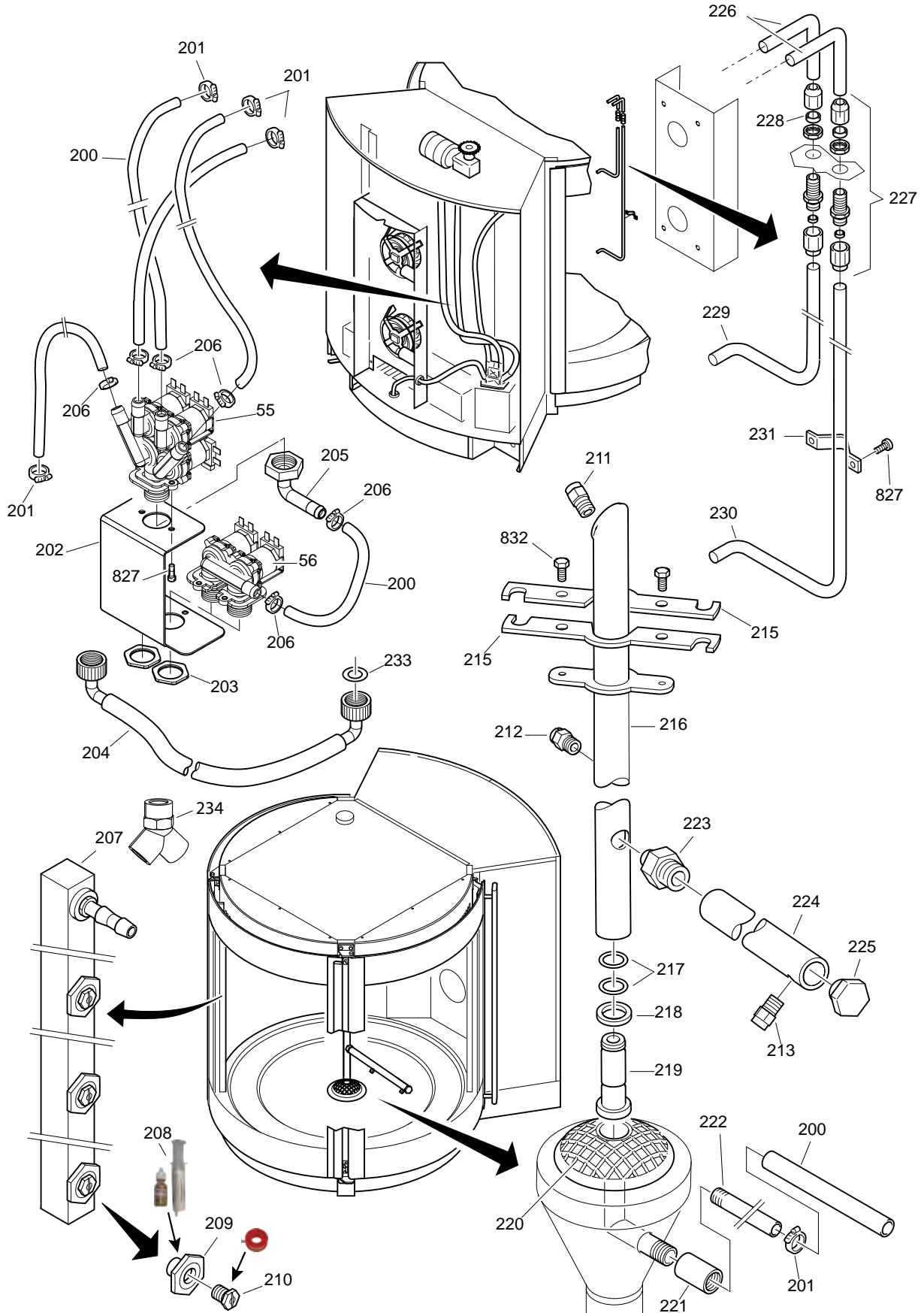

Pos	Part nr	Qty	Unit	Description
55	9191200	1	Pcs	Valve, quadruple 110-127V60Hz
56	9191199	1	Pcs	Valve, double inlet 110-127V60Hz
200	3500049	7,5	Mtr	Hose 9,5 x 16
201	9191295	4	Pcs	Hose clip, 15-17mm
202	9194483	1	Pcs	Bracket valve construction
203	9194457	2	Pcs	Nut, 3/4"
204	9191203	2	Pcs	Water supply hose
205	9301077	1	Pcs	Hose pillar 1/2"-90° -3/4"gland
206	9191294	6	Pcs	Hose clip, 17-19mm
207	9190498	1	Pcs	Sprayer pipe, side post
209	9192330	3	Pcs	Nipple adapter 1/4"-1/8"
210	9191270	3	Pcs	Sprayer, sidepost
211	9191086	1	Pcs	Sprayer, top (5006)
212	9191088	2	Pcs	Sprayer, middle (6510)
213	9191087	2	Pcs	Sprayer, bottom (11010)
215	9194320	2	Pcs	Mounting plate
216	9190463	1	Pcs	Sprayer tube, vertical
217	9191082	2	Pcs	O-ring 22 mm
218	9193069	1	Pcs	Seal ring, teflon
219	9192084	1	Pcs	Joint
220	9190429	1	Pcs	Drain riddle
221	9191118	1	Pcs	Female adapter, straight 1/4"x1/4"
222	9191117	1	Pcs	Hose pillar, long 1/4"
223	9191091	1	Pcs	Nipple adapter 3/8" - 1/4"
224	9192086	1	Pcs	Sprayer tube
225	9191090	1	Pcs	Plug 3/8" SS
226	9193065	2	Pcs	Pipe, water injection
227	3500048	2	Pcs	Joint
228	3500144	4	Pcs	Clamp ring
229	9193063	1	Pcs	Pipe, upper water injection
230	9193064	1	Pcs	Pipe, lower water injection
231	9194312	3	Pcs	Bracket
233	9191227	4	Pcs	Gasket Ø24xø16x2
234	9301053	1	Pcs	Y-threaded 3/4" (F-M-M)
8xx				See fasteners

	USED SHORT FORMS
Pos	Position number in drawing
Qty	This column shows the quantity that has been used in a unit.
Unit	This column shows how the part can be bought. Per Meter, per Piece, per cartridge etc."
Pcs	Pieces
Mtr	Meter
Dm	Decimeter
Ct	Cartridge
RI	Roll
AI	Aerosol
Tb	Tube
	USED SHORT FORMS IN FASTENERS
BH	Button Head
BNP	Brass Nickel Plated
CRPH	Cross Recess Pan Head
NP	Nickel Plated
SPH	Slotted Pan Head
SS	Stainless Steel
ZP	Zinc Plated

BLOWERS AND HEATING

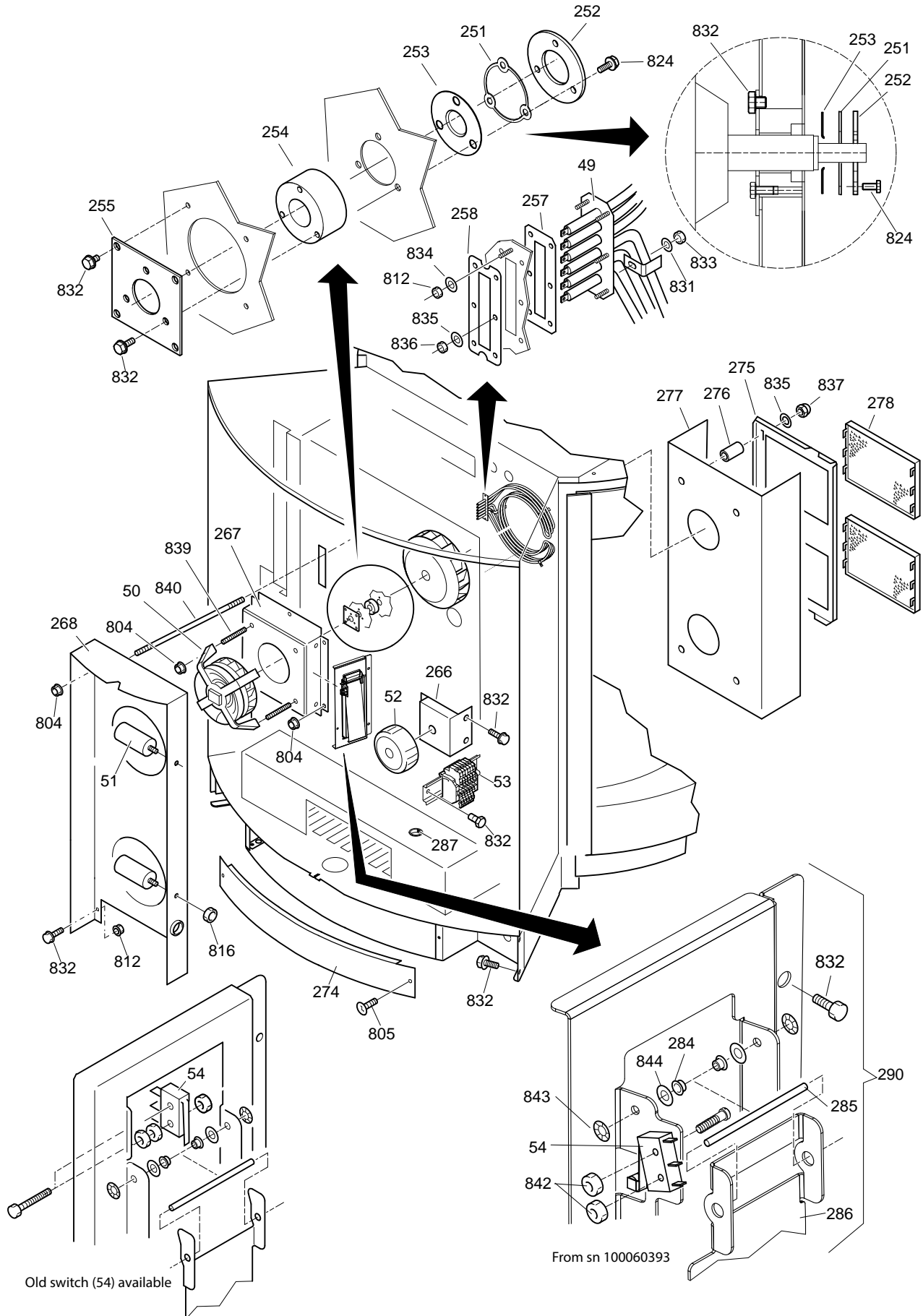

Pos	Part nr	Qty	Unit	Description
49	9192091s	0	Pcs	Heater, 10kW 208V slim flange untill sn100035862
49	9192254s	1	Pcs	Heater, 10kW 208V wide flange from sn100035863
49	9302045s	1	Pcs	Heater, 10,8kW 208V
50	9192225s	2	Pcs	Blower
51	9192034	2	Pcs	Capacitor 6 uF
52	9192227	1	Pcs	Transformer,208V-->208/165V
53	0166741	6	Pcs	Din rail
54	9191306	2	Pcs	End switch, from sn100060393
54	9191217		Pcs	End switch, until sn100060392
251	9194524	2	Pcs	Pressure ring, lipseal
252	9194522	2	Pcs	Pressure plate, lipseal
253	9192264	2	Pcs	Lipseal
254	9192043	2	Pcs	Spacer, shaft transit
255	9194022	2	Pcs	Mounting plate, square
257	9194506	2	Pcs	Gasket, heater, slim untill 1000035862
257	9194489	2	Pcs	Gasket, heater, wide from sn100035863
258	9194168	2	Pcs	Pressure plate, heater
266	9194469	1	Pcs	Bracket, transformer
267	9194035	2	Pcs	Construction profile
268	9194023	1	Pcs	Air suction channel, blowers
274	9194026	1	Pcs	Cover plate, curved, backside
275	9190457	1	Pcs	Filter support
276	9193095	4	Pcs	Spacer 24mm, Ø14x6,5mm
277	9190403	1	Pcs	Fan plate
278	9190048s	2	Pcs	Filter ass.
279	9194909	2	Pcs	Base, vane switch
284	9191305	4	Pcs	Plastic bearing 3 mm
285	9193088	2	Pcs	Axle, vane switch
286	9194910	2	Pcs	Swing, vane switch
287	9171015	1	Pcs	Grommet
290	9190104s	2	Pcs	Vane switch ass.
8xx				See fasteners

	USED SHORT FORMS
Pos	Position number in drawing
Qty	This column shows the quantity that has been used in a unit.
Unit	This column shows how the part can be bought. Per Meter, per Piece, per cartridge etc."
Pcs	Pieces
Mtr	Meter
Dm	Decimeter
Ct	Cartridge
RI	Roll
AI	Aerosol
Tb	Tube
	USED SHORT FORMS IN FASTENERS
BH	Button Head
BNP	Brass Nickel Plated
CRPH	Cross Recess Pan Head
NP	Nickel Plated
SPH	Slotted Pan Head
SS	Stainless Steel
ZP	Zinc Plated

ROTOR DRIVE SYSTEM

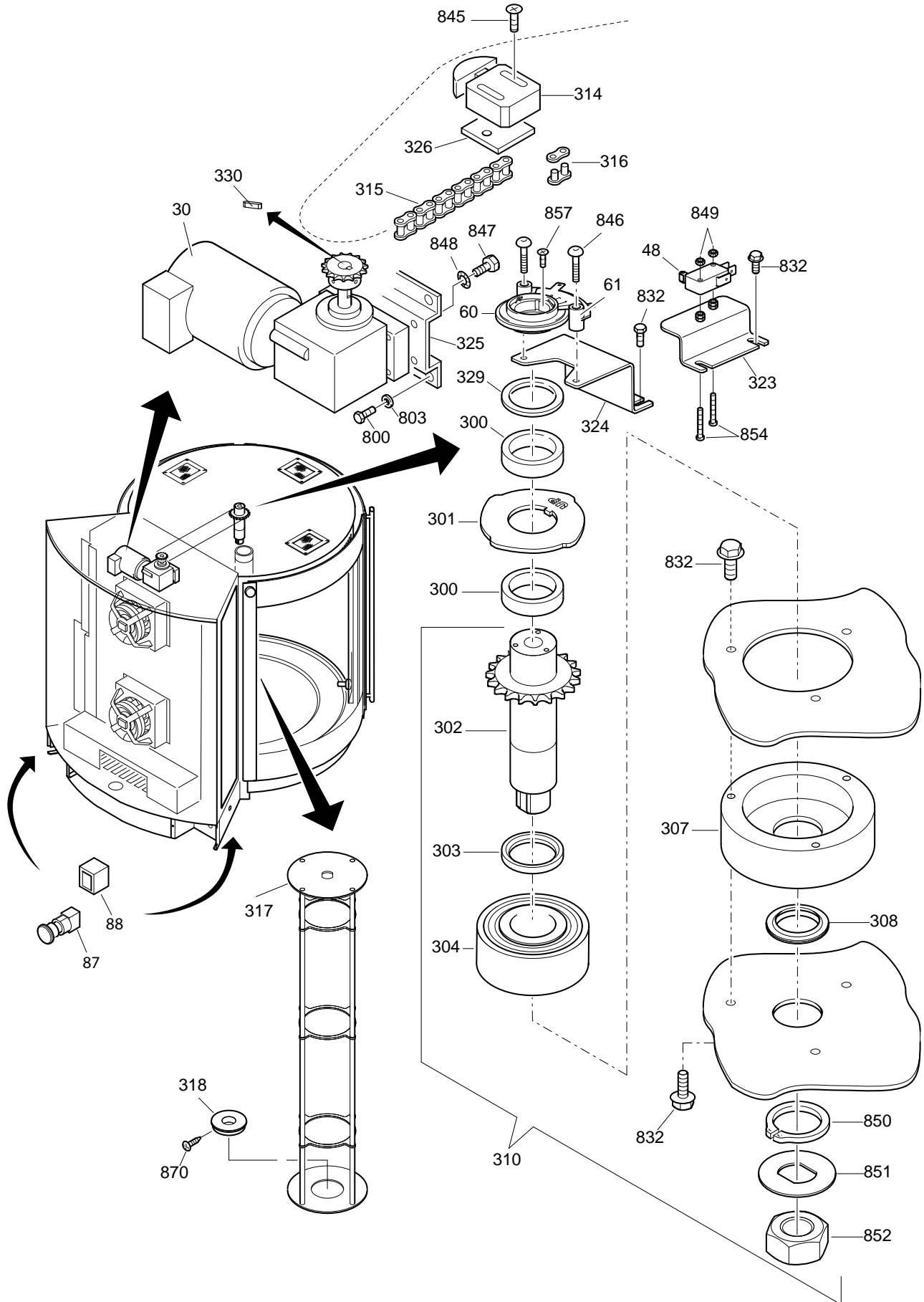

Pos	Part nr	Qty	Unit	Description
30	9190126	1	Pcs	Gearmotor with chain-wheel
31	9077101	1	Pcs	Capacitor 2,5 uF
48	3500109	3	Pcs	End switch
60	9192018	1	Pcs	Sliding ring
61	9192019	1	Pcs	Sliding contact
87	9291002		Pcs	Rotorbutton
88	9291003		Pcs	Switch
300	9192242	2	Pcs	Spacer ring 9mm, Ø40x30,5
301	9194448	1	Pcs	Positioning cam disc
302	9190412	1	Pcs	Rotor shaft, chain wheel, ass.
303	9192053	1	Pcs	Spacer ring 5mm, Ø40x30,5 countersunk
304	9192017	1	Pcs	Ball bearing
307	9192048	1	Pcs	Bearing block
308	9192012	1	Pcs	Seal ring
310	9190154s	1	Pcs	Rotor shaft + bearing assembly
314	9150145	1	Pcs	Chain tensioner
315	9192014	1	Pcs	Chain 3/8 x 7/32
316	9192015	1	Pcs	Link for Chain
317	9190400	1	Pcs	Rotor, column
318	9192092	1	Pcs	Teflon bearing
323	9194502	1	Pcs	Bracket, position switch
324	9194445	1	Pcs	Bracket, sliding contact
325	9194447	1	Pcs	Bracket, gearmotor parvalux
326	9194509	1	Pcs	Adjustingplate, chain tensioner
329	9194221	1	Pcs	Spacer ring 1mm, Ø40x31,5
330	9191210	1	Pcs	Spie
850	9191045	1	Pcs	Circlip, 30 mm external
851	9194508	1	Pcs	Lock washer M22
852	9192075	1	Pcs	Nut M22 x 1,5, SS
8xx				See fasteners

	USED SHORT FORMS
Pos	Position number in drawing
Qty	This column shows the quantity that has been used in a unit.
Unit	This column shows how the part can be bought. Per Meter, per Piece, per cartridge etc."
Pcs	Pieces
Mtr	Meter
Dm	Decimeter
Ct	Cartridge
RI	Roll
AI	Aerosol
Tb	Tube
	USED SHORT FORMS IN FASTENERS
BH	Button Head
BNP	Brass Nickel Plated
CRPH	Cross Recess Pan Head
NP	Nickel Plated
SPH	Slotted Pan Head
SS	Stainless Steel
ZP	Zinc Plated

DRAIN AND VENT SYSTEM

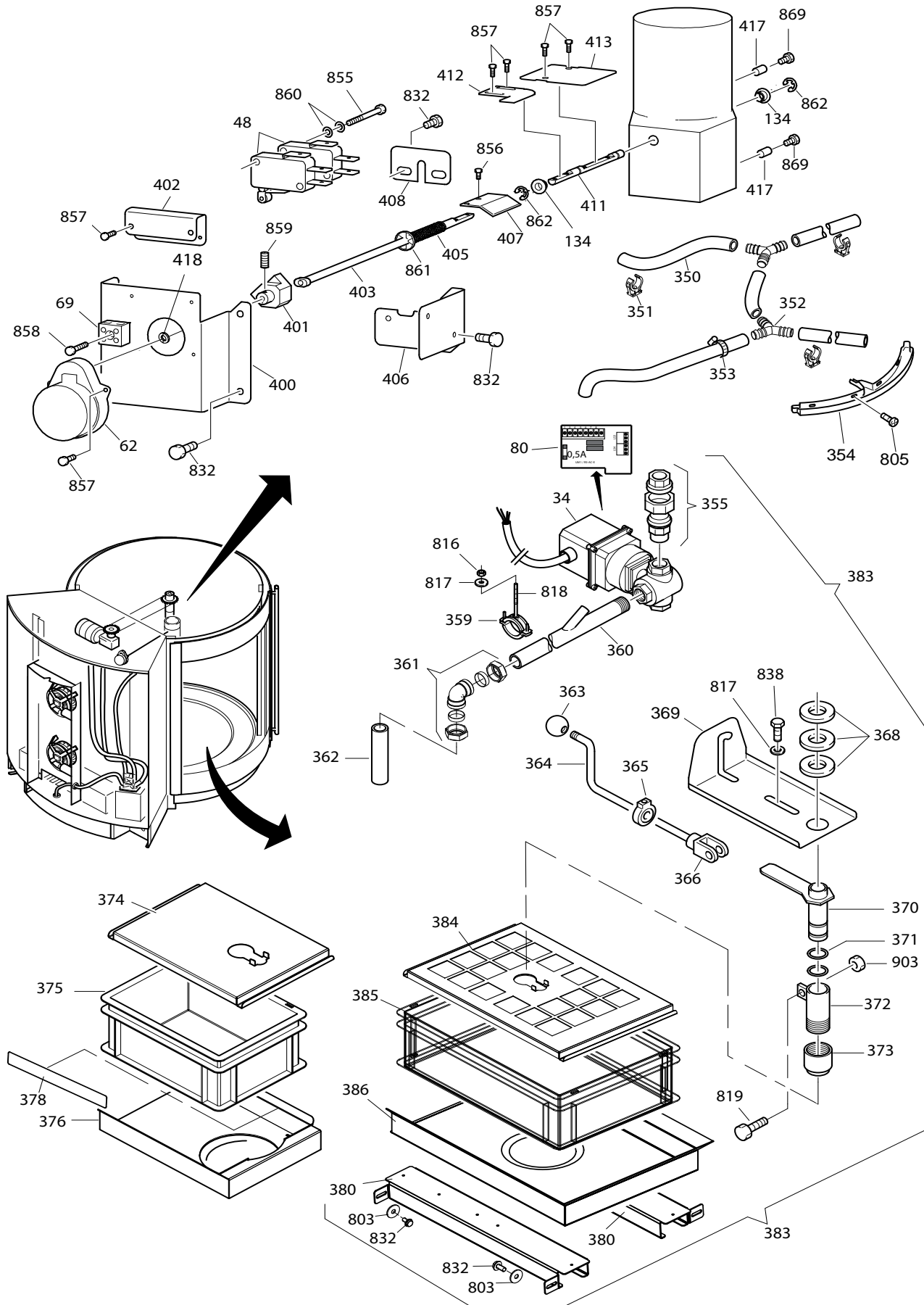

Pos	Part nr	Qty	Unit	Description
34	9191092	1	Pcs	Valve, 3-way
48	3500109	3	Pcs	End switch
62	9191198	1	Pcs	Gearmotor
69	9171110	1	Pcs	Terminal block, 2 pole porcelain
80	9191302			Pcb for 3-way valve (fused with 0,5A 5x20mm)
134	9191085	2	Pcs	Plastic bearing 6 mm
350	9191145	2,15	Mtr	Hose, dripwater 19x29mm
351	9191142	3	Pcs	Hose mounting clip 28mm
352	9191141	2	Pcs	Y-splitter
353	9191251	1	Pcs	Hose clip 28mm
354	9192275	3	Pcs	drip tray, SS
355	9191079	1	Pcs	Union Joint 1"
359	2650217	1	Pcs	Suspension clip
360	9190501	1	Pcs	Drain pipe, long
361	3500052	1	Pcs	Clamp knee 35mm
362	9192197	1	Pcs	Drain pipe, short
363	6791000	1	Pcs	Knob
364	9192216	1	Pcs	Locking bar
365	3701100	1	Pcs	Bearing block
366	9191147	1	Pcs	Gaff
368	9194431	3	Pcs	Spacer ring
369	9194423	1	Pcs	Bracket, locking bar
370	9190505	1	Pcs	Inner sliding pipe, grease drain
371	9191148	2	Pcs	O-ring 29x3,5mm
372	9190506	1	Pcs	Outer sliding pipe, grease drain
373	9192215	1	Pcs	Cone, outer sliding pipe (Spout)
374	9190552	1	Pcs	Cover, grease container
375	9191149	1	Pcs	Grease container
376	9194840	1	Pcs	Support, grease container
378	9194169	1	Pcs	Shim conductor greasecontainer
380	9194920	2	Pcs	Support, grease container support.
383	9198117s			Grease collector kit
384	9190568	1	Pcs	Cover, grease container 40x60
385	9191249	1	Pcs	Grease container 40x60
386	9194917	1	Pcs	Support, grease container 40x60
400	9194477	1	Pcs	Bracket, vent motor
401	9193101	1	Pcs	Camshaft
402	9194472	1	Pcs	Mounting plate, end switch
403	9190510	1	Pcs	Shaft vent mechanism, long
405	3500106	1	Pcs	Spring
406	9194473	1	Pcs	Bracket
407	9194488	1	Pcs	Spring plate

Pos	Part nr	Qty	Unit	Description
408	9194328	1	Pcs	Mounting plate
411	9193100	1	Pcs	Shaft vent mechanism, short
412	9194476	1	Pcs	Lever
413	9194474	1	Pcs	Valve
417	9191216	0,2	Dm	Hose, 5x3 silicon transparant
418	9191303	1	Pcs	o-ring, rubber
8xx				See fasteners

	USED SHORT FORMS
Pos	Position number in drawing
Qty	This column shows the quantity that has been used in a unit.
Unit	This column shows how the part can be bought. Per Meter, per Piece, per cartridge etc."
Pcs	Pieces
Mtr	Meter
Dm	Decimeter
Ct	Cartridge
RI	Roll
AI	Aerosol
Tb	Tube
	USED SHORT FORMS IN FASTENERS
BH	Button Head
BNP	Brass Nickel Plated
CRPH	Cross Recess Pan Head
NP	Nickel Plated
SPH	Slotted Pan Head
SS	Stainless Steel
ZP	Zinc Plated

SOAP INJECTION SYSTEM

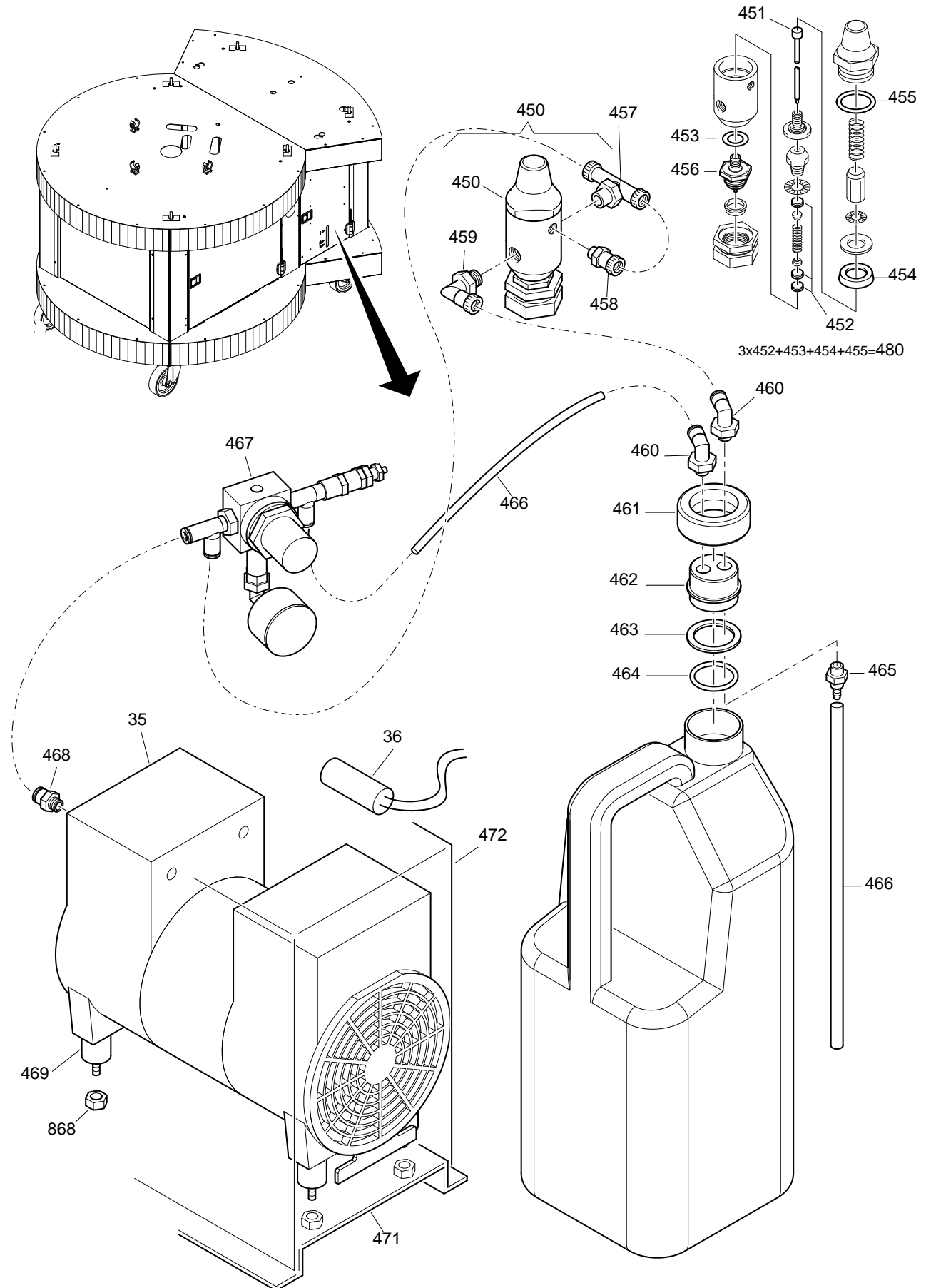

Pos	Part nr	Qty	Unit	Description
35	9191202s	1	Pcs	Compressor 20psi 115V 60Hz 91,5L/ min
36	3500641	1	Pcs	Capacitor 16uF 450V
450	9191153s	1	Pcs	Air controlled soap mister
451	9191290	1	Pcs	Needle, soap mister
452	9191285	3	Pcs	O-ring, soap mister
453	see 480	1	Pcs	Ptfe gasket ring, soap mister
454	see 480	1	Pcs	Cuff, soap mister
455	see 480	1	Pcs	O-ring, soap mister
456	9191291	1	Pcs	Sprayer, air controlled nozzle
457	9191158	1	Pcs	Branch tee adapter 1/4"x 6mm BNP
458	9191252	1	Pcs	Straight adapter 1/8"x 6mm BNP
459	9191177	1	Pcs	Elbow adaptor SS 1/4"x 6mm
460	9191184	2	Pcs	Elbow adaptor SS 1/8"x 6mm, revolving
461	9192340	1	Pcs	Swivel, soap bottle cap
462	9192341	1	Pcs	Plug, soap bottle cap
463	9192344	1	Pcs	Seal ring, silicon
464	9191283	1	Pcs	O-ring silicon
465	9191171	1	Pcs	Straight adaptor 1/8"x 1/8"clamp
466	9191157	8	Mtr	Hose, ptfe 6.0mm
467	9192249	1	Pcs	Pressure regulator ass. 250mBar
468	9192247	1	Pcs	Straight adaptor 1/4"x 6mm BNP
469	9191156	4	Pcs	Vibration absorber
471	9194464	1	Pcs	Mounting bracket Compressor
472	9194492	1	Pcs	Cover compressor
480	9191292s	1	Pcs	Service kit, air controlled nozzle (3x 452 + 453 + 454 + 455)
8xx				See fasteners

	USED SHORT FORMS
Pos	Position number in drawing
Qty	This column shows the quantity that has been used in a unit.
Unit	This column shows how the part can be bought. Per Meter, per Piece, per cartridge etc."
Pcs	Pieces
Mtr	Meter
Dm	Decimeter
Ct	Cartridge
RI	Roll
AI	Aerosol
Tb	Tube
	USED SHORT FORMS IN FASTENERS
BH	Button Head
BNP	Brass Nickel Plated
CRPH	Cross Recess Pan Head
NP	Nickel Plated
SPH	Slotted Pan Head
SS	Stainless Steel
ZP	Zinc Plated

UNDERFRAME (UNTILL SER NR. 100055089, SEPTEMBER 2011)

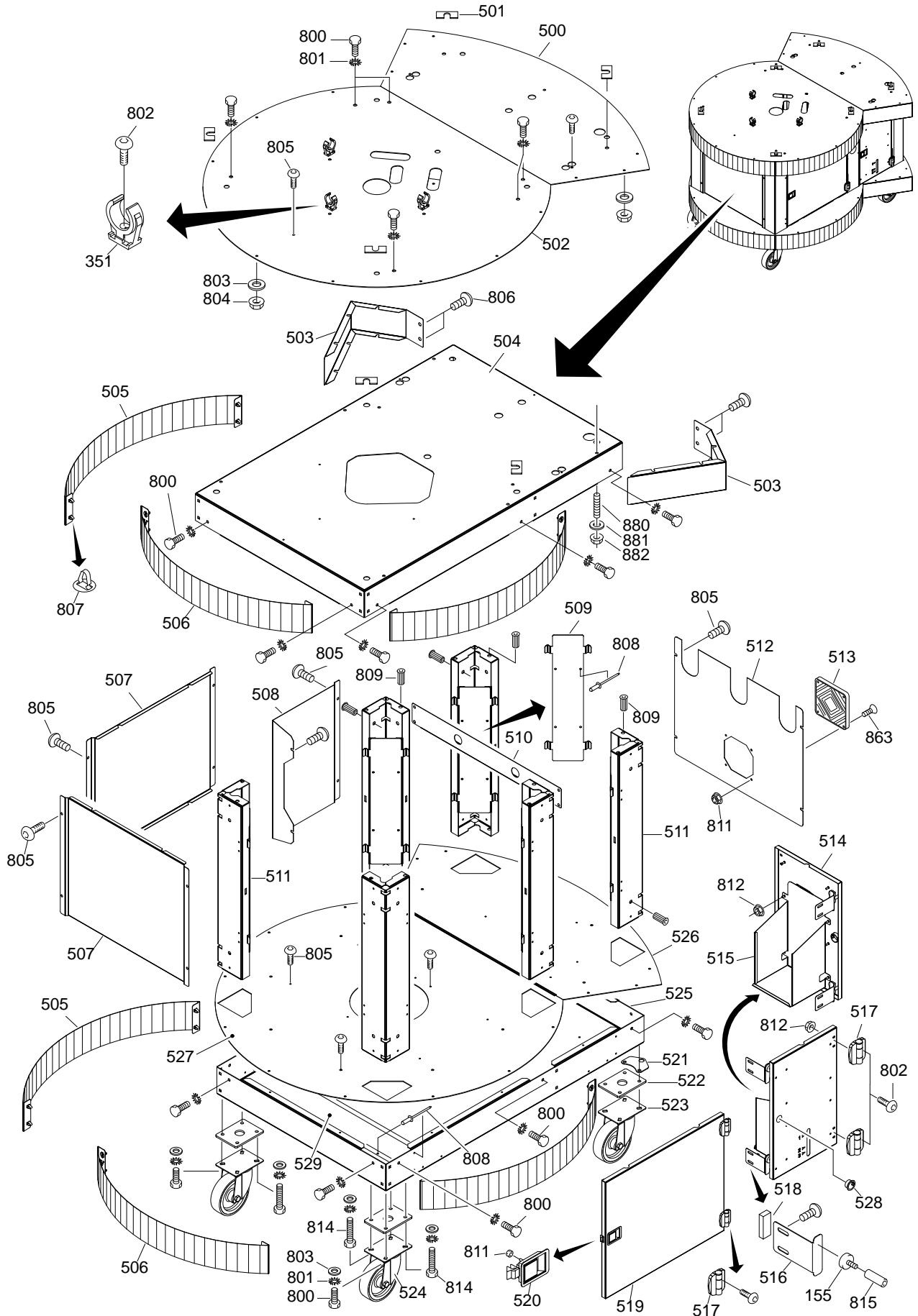

Pos	Part nr	Qty	Unit	Description
155	9084077	2	Pcs	Magnet
500	9194279	1	Pcs	Top plate, rear
501	9194264	6	Pcs	Adjusting plate, (shim)
502	9194278	1	Pcs	Top plate, front
503	9194255	4	Pcs	Corner cover
504	9194251	1	Pcs	Top, frame
505	9194256	4	Pcs	Side cover, curved Replaced by pos 530 (next page)
506	9194257	2	Pcs	Front cover, curved Replaced by pos 531 (next page)
507	9194347	2	Pcs	Side panel
508	9194258	1	Pcs	Side-rear panel
509	9194340	6	Pcs	Post cover
510	9194466	1	Pcs	Bracket, pressure regulator valve
511	9194254	6	Pcs	Post
512	9194436	1	Pcs	Rear panel
513	9191124	1	Pcs	Filter
514	9194432	1	Pcs	Right door
515	9194434	1	Pcs	Bottle holder
516	9194446	2	Pcs	Doorstop bracket
517	9191106	4	Pcs	Hinge
518	9191182	1	Pcs	Magnet 36x15x11
519	9194331	1	Pcs	Door, underframe
520	9191107	1	Pcs	Doorlock
521	9174230	1	Pcs	Thethering bracket
522	9194455	4	Pcs	Base plate, castors
523	9191104	2	Pcs	Castor
524	9191105	2	Pcs	Castor with brake
525	9194250	1	Pcs	Underframe
526	9194253	1	Pcs	Bottomplate, rear
527	9194252	1	Pcs	Bottomplate, front
528	9070840	1	Pcs	Grommet 15mm
529	9194468	2	Pcs	Construction profile
8xx				See fasteners

	USED SHORT FORMS
Pos	Position number in drawing
Qty	This column shows the quantity that has been used in a unit.
Unit	This column shows how the part can be bought. Per Meter, per Piece, per cartridge etc."
Pcs	Pieces
Mtr	Meter
Dm	Decimeter
Ct	Cartridge
RI	Roll
AI	Aerosol
Tb	Tube
	USED SHORT FORMS IN FASTENERS
BH	Button Head
BNP	Brass Nickel Plated
CRPH	Cross Recess Pan Head
NP	Nickel Plated
SPH	Slotted Pan Head
SS	Stainless Steel
ZP	Zinc Plated

UNDERFRAME (FROM SER NR. 100055090, OCTOBER 2011)

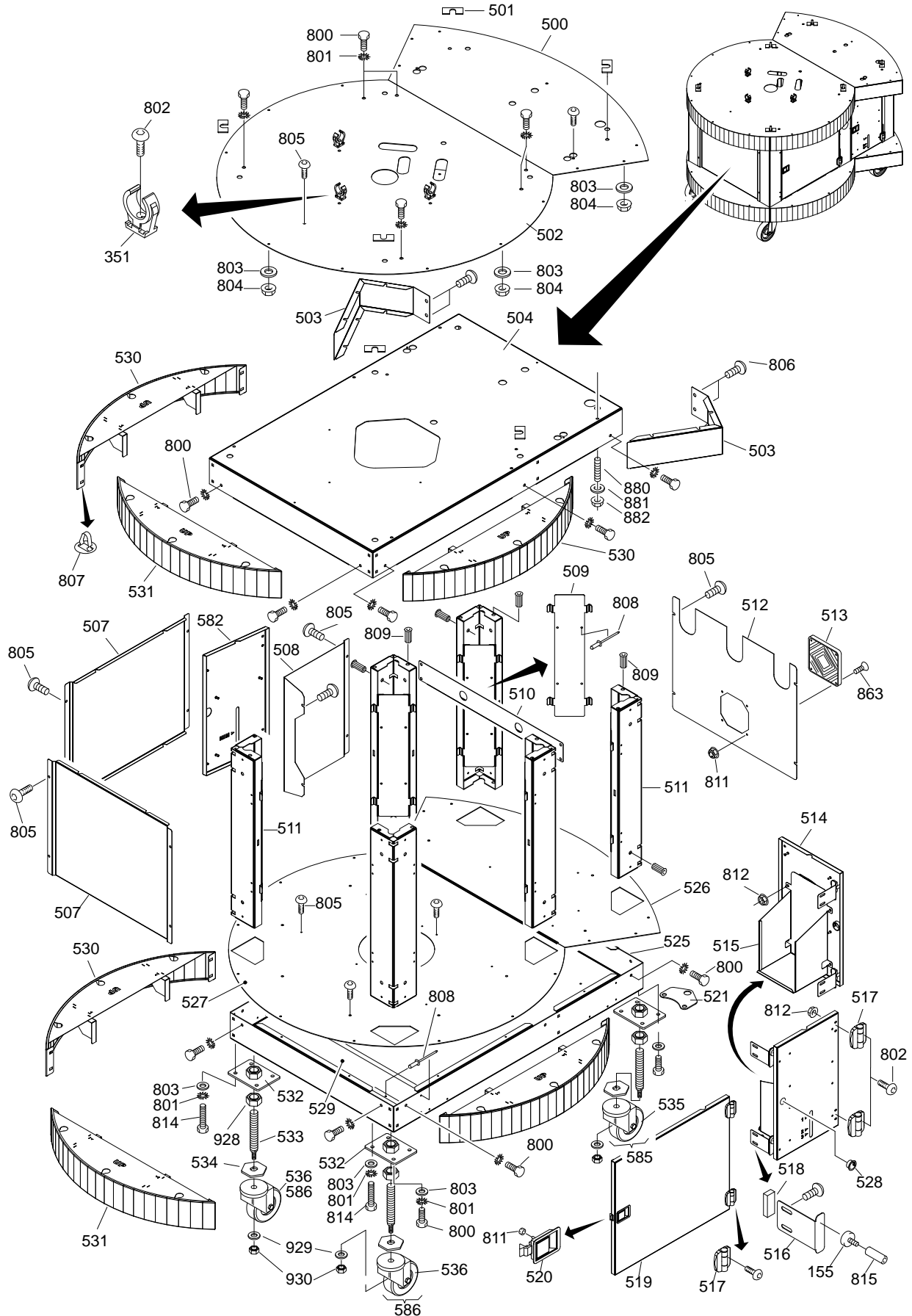

Pos	Part nr	Qty	Unit	Description
155	9084077	2	Pcs	Magnet
500	9194279	1	Pcs	Top plate, rear
501	9194264	6	Pcs	Adjusting plate, (shim)
502	9194278	1	Pcs	Top plate, front
503	9194255	4	Pcs	Corner cover
504	9194251	1	Pcs	Top, frame
507	9194347	2	Pcs	Side panel
508	9194258	1	Pcs	Side-rear panel
509	9194340	6	Pcs	Post cover
510	9194466	1	Pcs	Bracket, pressure regulator valve
511	9194254	6	Pcs	Post
512	9194436	1	Pcs	Rear panel
513	9191124	1	Pcs	Filter
514	9194432	1	Pcs	Right door
515	9194434	1	Pcs	Bottle holder
516	9194446	2	Pcs	Doorstop bracket
517	9191106	4	Pcs	Hinge
518	9191182	1	Pcs	Magnet 36x15x11
519	9194331	1	Pcs	Door, underframe
520	9191107	1	Pcs	Doorlock
521	9174230	1	Pcs	Thethering bracket
525	9194250	1	Pcs	Underframe
526	9194253	1	Pcs	Bottomplate, rear
527	9194252	1	Pcs	Bottomplate, front
528	9070840	1	Pcs	Grommet 15mm
529	9194468	2	Pcs	Construction profile
530	9190563	4	Pcs	Side cover, curved
531	9190564	2	Pcs	Front cover, curved
532	9190518	4	Pcs	Mounting plate
533	9192346	4	Pcs	Stud M24 x M12
534	9194867	4	Pcs	Hex plate, adjustable castor
535	3701077	2	Pcs	Castor, Ø100, H=125
585	9190176s			Adj. Castor ass.
536	3701078	2	Pcs	Castor with brake, Ø100, H=125
586	9190177s			Adj. Castor with brake ass.
582	9194456		Pcs	Rear panel mirrored
585	9190176s			Adj. Castor ass.
586	9190177s			Adj. Castor with brake ass.
8xx				See fasteners

	USED SHORT FORMS
Pos	Position number in drawing
Qty	This column shows the quantity that has been used in a unit.
Unit	This column shows how the part can be bought. Per Meter, per Piece, per cartridge etc."
Pcs	Pieces
Mtr	Meter
Dm	Decimeter
Ct	Cartridge
RI	Roll
Al	Aerosol
Tb	Tube
	USED SHORT FORMS IN FASTENERS
BH	Button Head
BNP	Brass Nickel Plated
CRPH	Cross Recess Pan Head
NP	Nickel Plated
SPH	Slotted Pan Head
SS	Stainless Steel
ZP	Zinc Plated

UNDERFRAME (BUILD-IN)

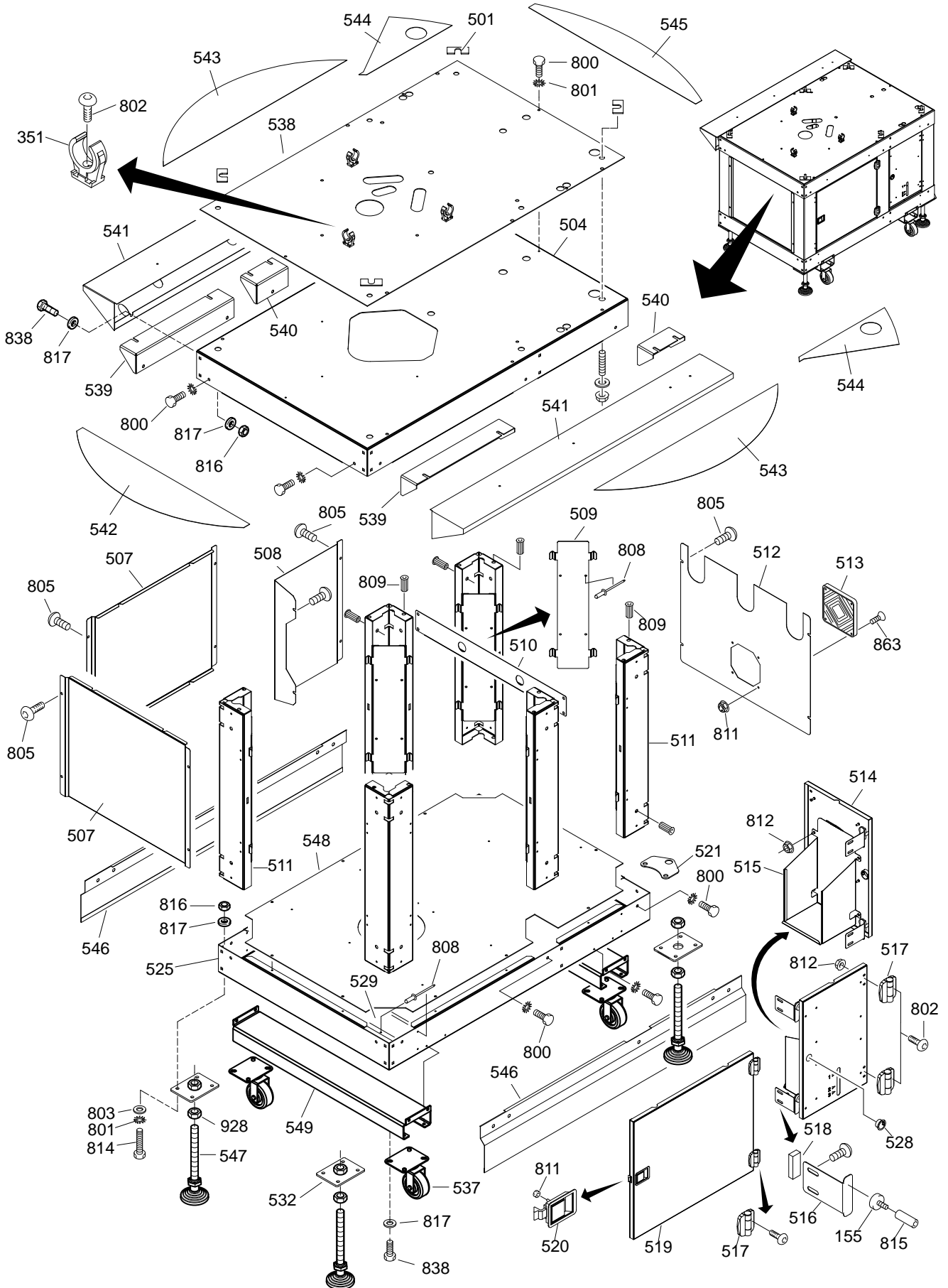

Pos	Part nr	Qty	Unit	Description
155	9084077	2	Pcs	Magnet
351	9191142	3	Pcs	Hose mounting clip 28mm
501	9194264	6	Pcs	Adjusting plate, (shim)
504	9194251	1	Pcs	Top, frame
507	9194347	2	Pcs	Side panel
508	9194258	1	Pcs	Side-rear panel
509	9194340	6	Pcs	Post cover
510	9194466	1	Pcs	Bracket, pressure regulator valve
511	9194254	6	Pcs	Post
512	9194436	1	Pcs	Rear panel
513	9191124	1	Pcs	Filter
514	9194432	1	Pcs	Right door
515	9194434	1	Pcs	Bottle holder
516	9194446	2	Pcs	Doorstop bracket
517	9191106	4	Pcs	Hinge
518	9191182	1	Pcs	Magnet 36x15x11
519	9194331	1	Pcs	Door, underframe
520	9191107	1	Pcs	Doorlock
521	9174230	1	Pcs	Thethering bracket
525	9194250	1	Pcs	Underframe
528	9070840	1	Pcs	Grommet 15mm
529	9194468	2	Pcs	Construction profile
532	9190518	4	Pcs	Mounting plate
537	9172065	5	Pcs	Castor, Ø80, H=110
538	9194559	1	Pcs	Top plate
539	9194572	1	Pcs	Bracket
540	9194573	1	Pcs	Bracket
541	9194574	1	Pcs	Beam, for controls on right side
541	9194578	1	Pcs	Beam, for controls on left side
542	9194564	1	Pcs	Finishing plate, front side
543	9194562	1	Pcs	Finishing plate, controls right side
543	9194562	1	Pcs	Finishing plate, controls left side
544	9194568	1	Pcs	Finishing plate, controls right side
544	9194570	1	Pcs	Finishing plate, controls left side
545	9194566	1	Pcs	Finishing plate, back side
546	9194575	1	Pcs	Plinth, for controls on right side
546	9194577	1	Pcs	Plinth, for controls on left side
547	9191260	4	Pcs	Adjustable leg, M24x200, foot Ø80
548	9194558	1	Pcs	Cover plate stand, bottom
549	9194557	2	Pcs	Beam, for wheels
8xx				See fasteners

	USED SHORT FORMS
Pos	Position number in drawing
Qty	This column shows the quantity that has been used in a unit.
Unit	This column shows how the part can be bought. Per Meter, per Piece, per cartridge etc."
Pcs	Pieces
Mtr	Meter
Dm	Decimeter
Ct	Cartridge
RI	Roll
Al	Aerosol
Tb	Tube
	USED SHORT FORMS IN FASTENERS
BH	Button Head
BNP	Brass Nickel Plated
CRPH	Cross Recess Pan Head
NP	Nickel Plated
SPH	Slotted Pan Head
SS	Stainless Steel
ZP	Zinc Plated

CHASSIS AND SHEET METAL

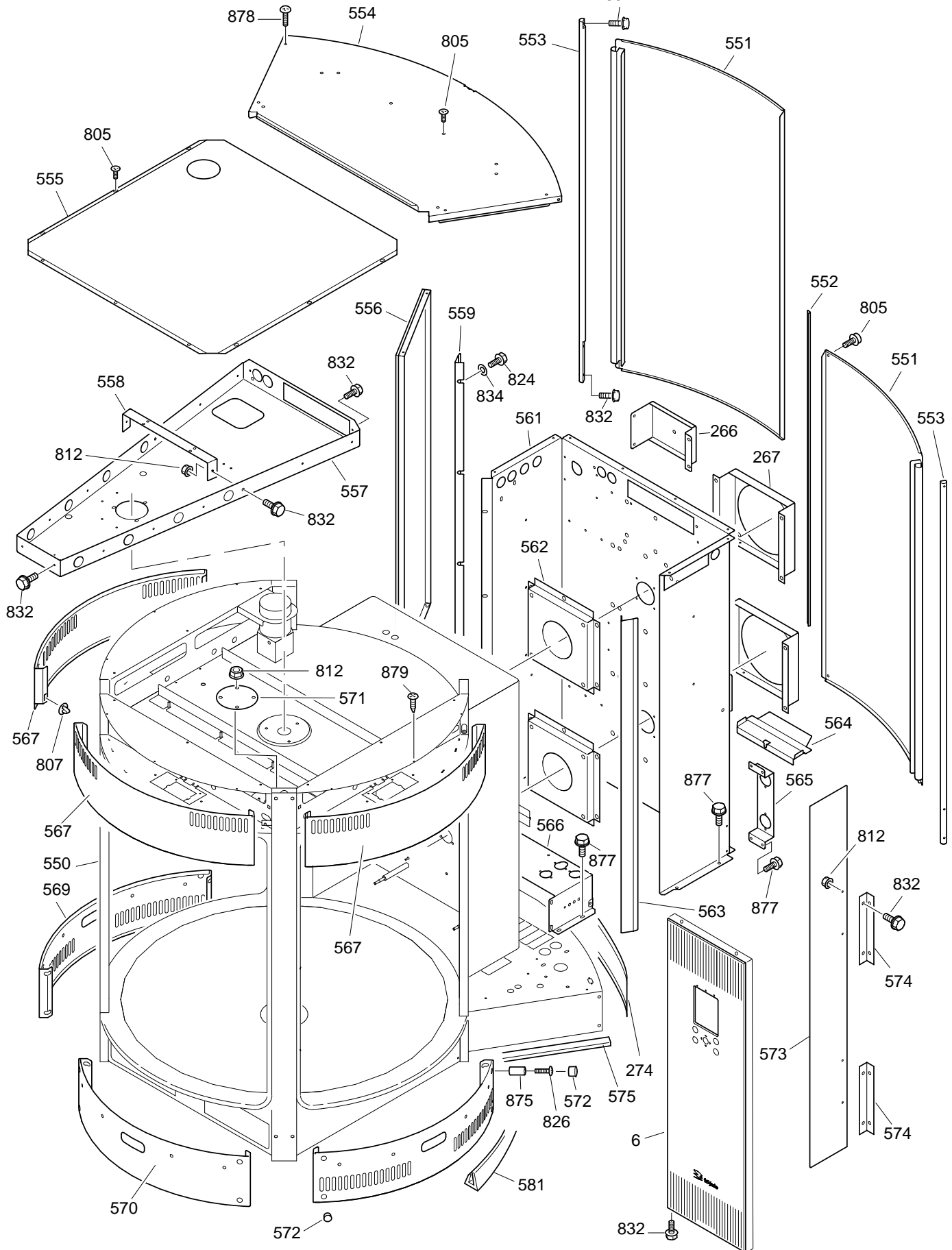

Pos	Part nr	Qty	Unit	Description
6	9190129		Pcs	Control panel, ass (purple) until sn100071948
6	9190206s	1	Pcs	Control panel, ass (black) from sn100071949
266	9194469	1	Pcs	Bracket, transformer
267	9194035	2	Pcs	Construction profile
274	9194026	1	Pcs	Cover plate, curved, backside
550	9190444	1	Pcs	Multisserie frame, welding assembly
551	9190413	2	Pcs	Door, electrical compartment
552	9194829	1	Pcs	L shaped profile
553	9192049	2	Pcs	Hinge axle service door
554	9194013	1	Pcs	Rear top plate
555	9194007	1	Pcs	Centre top plate
556	9190130		Pcs	Name panel ass (purple) until sn100071948
556	9190207s	1	Pcs	Name panel ass. (black) from sn100071949
557	9194016	1	Pcs	Chain box
558	9194480	1	Pcs	Support strip for air and soap tube
559	9194084	1	Pcs	Cover plate left side
561	9194008	1	Pcs	U shaped construction panel
562	9194096	2	Pcs	Support profile blower (not in drawing)
563	9194085	1	Pcs	Cover plate right side
564	9194545	1	Pcs	Leak guard
565	9194481	1	Pcs	Bracket, 125V socket
566	9194024	1	Pcs	Lower air suction channel blowers
567	9194100	3	Pcs	Curved cover plate, top
569	9194865	2	Pcs	Curved cover plate, L+R side
570	9194866	1	Pcs	Curved cover plate, middle
571	9194816	1	Pcs	Cover plate, air inlet
572	2005250	12	Pcs	Finishing plug
573	9194491	1	Pcs	Protection plate, lexan
574	9194486	2	Pcs	L shaped bracket
575	9191253	0,8	Mtr	Rubber seal strip
581	9192259	3	Mtr	Finishing profile, rubber
8xx				See fasteners

	USED SHORT FORMS
Pos	Position number in drawing
Qty	This column shows the quantity that has been used in a unit.
Unit	This column shows how the part can be bought. Per Meter, per Piece, per cartridge etc."
Pcs	Pieces
Mtr	Meter
Dm	Decimeter
Ct	Cartridge
RI	Roll
AI	Aerosol
Tb	Tube
	USED SHORT FORMS IN FASTENERS
BH	Button Head
BNP	Brass Nickel Plated
CRPH	Cross Recess Pan Head
NP	Nickel Plated
SPH	Slotted Pan Head
SS	Stainless Steel
ZP	Zinc Plated

UNDERFRAME 2017

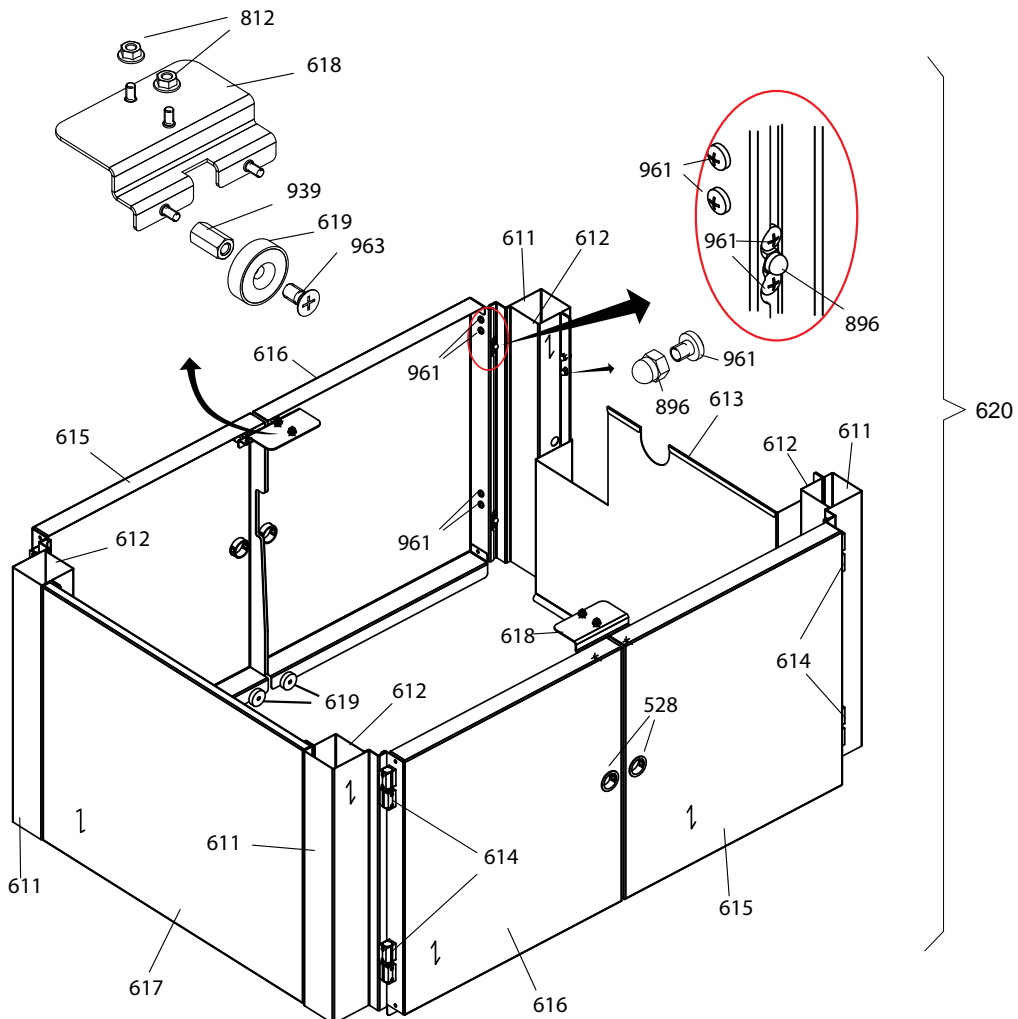
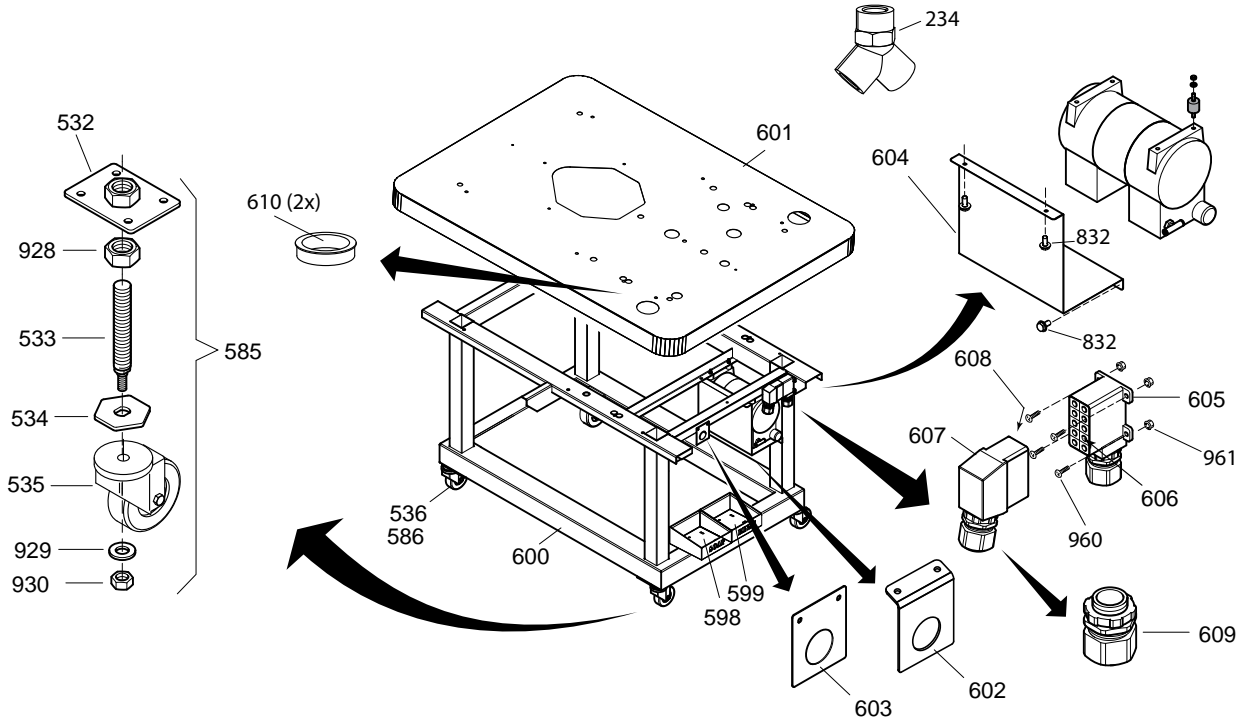

Pos	Part nr	Qty	Unit	Description
234	9301053	1	Pcs	Y-threaded 3/4" (F-M-M)
515	9194434	1	Pcs	Bottle holder
528	9070840	1	Pcs	Grommet 15mm
532	9190518	4	Pcs	Base plate, castors with nut
533	9192346	4	Pcs	Stud M24 x M12
534	9194867	4	Pcs	Hex plate, adjustable castor
535	3701077	2	Pcs	Castor, Ø100, H=125
536	3701078	2	Pcs	Castor with brake, Ø100, H=125
585	9190176s			Adj. Castor ass.
586	9190177s			Adj. Castor with brake ass.
598	9194934	1	Pcs	Holder, Soap bottle.
599	9194935	1	Pcs	Holder, Rinse agent bottle.
600	9190567	1	Pcs	Chassis, underframe
601	9190566	1	Pcs	Top plate
602	9194925	1	Pcs	Bracket, pressure reducer US
603	9194906	1	Pcs	Bracket, pressure reducer 250mbar AUS
604	9194907	1	Pcs	Shield for compressor
605	3721155	1	Pcs	Socket, Harting panelmount 10p
606	3721158	1	Pcs	Contact block, female Harting 10p
607	3721156	1	Pcs	Plug, Harting 10p
608	3721157	1	Pcs	Contactblock, male Harting 10p
609	9261022	1	Pcs	Cable gland M25
610	9281021	2	Pcs	Grommet
611	9194938	4	Pcs	cover outside, leg underframe
612	9194939	4	Pcs	cover inside, leg underframe
613	9194942	1	Pcs	Side panel, right
614	9191330	8	Pcs	Hinge
615	9194940	2	Pcs	Door, right
616	9194944	2	Pcs	Door, left
617	9194941	1	Pcs	Side panel, left
618	9194943	2	Pcs	Mounting plate, magnets
619	9191328	8	Pcs	Magnet
620	9198118			Cladding, underframe 2017
8xx				See fasteners

	USED SHORT FORMS
Pos	Position number in drawing
Qty	This column shows the quantity that has been used in a unit.
Unit	This column shows how the part can be bought. Per Meter, per Piece, per cartridge etc."
Pcs	Pieces
Mtr	Meter
Dm	Decimeter
Ct	Cartridge
RI	Roll
AI	Aerosol
Tb	Tube
	USED SHORT FORMS IN FASTENERS
BH	Button Head
BNP	Brass Nickel Plated
CRPH	Cross Recess Pan Head
NP	Nickel Plated
SPH	Slotted Pan Head
SS	Stainless Steel
ZP	Zinc Plated

GREASE SEPARATOR

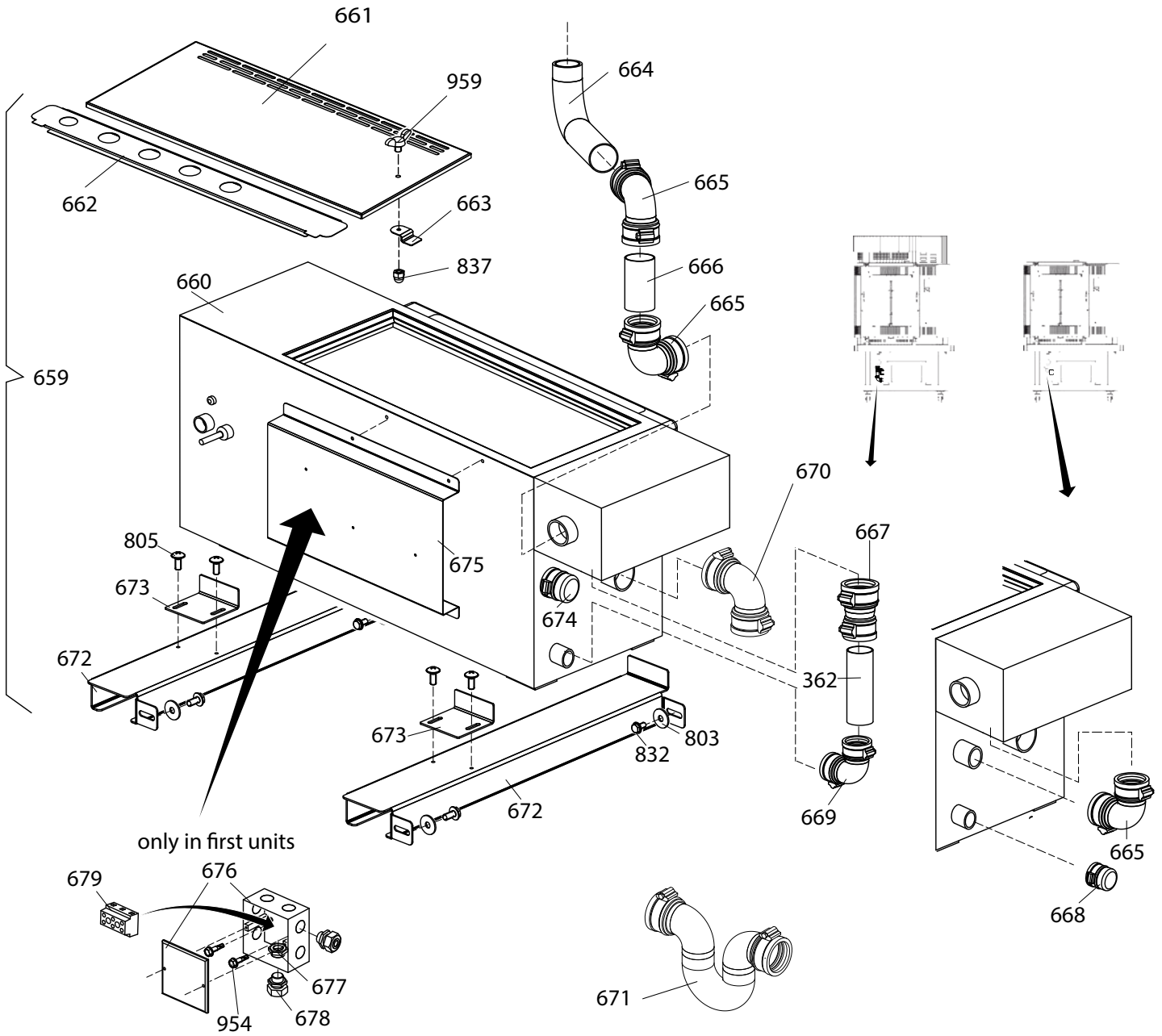

Pos	Part nr	Qty	Unit	Description
362	9192197	1	Pcs	Tube Ø35x100
659	9198116s			Grease Separator kit 115V
660	7100022	1	Pcs	Grease Separator 115V
661	9194929	1	Pcs	Top panel, Grease separator
662	9194930	1	Pcs	Top panel hose, Grease separator
663	9194931	1	Pcs	Latch, Grease separator
664	9192364	1	Pcs	Drain, Multiserie-Grease separator
665	7100041	2	Pcs	Elbow flexible D40 incl. 2 clamps
666	9193152	1	Pcs	Tube Ø40x70
667	7100038	1	Pcs	Adaptor D34-D40, incl. 2 clamps
668	7100028	1	Pcs	Endcap D34 incl. 1 clamp
669	7100026	1	Pcs	Elbow flexible D34 incl. 2 clamps
670	7100025	1	Pcs	Elbow flexible D50 incl. 2 clamps
671	7100027	1	Pcs	Running trap D54 (Siphon)
672	9194919	2	Pcs	Support between stand
673	9194921	2	Pcs	Locking bracket
674	7100034	1	Pcs	Endcap D40 incl. 1 clamp
675	9194932	1	Pcs	Mounting plate, boiler
676	9191322	1	Pcs	Cable box
677	9291108	2	Pcs	Nut M20, Cable gland brass chromed
678	9291107	2	Pcs	Cable gland M20 Brass chromed
679	9044564	1	Pcs	Terminal block G10/3 1-2-3
8xx				See fasteners

	USED SHORT FORMS
Pos	Position number in drawing
Qty	This column shows the quantity that has been used in a unit.
Unit	This column shows how the part can be bought. Per Meter, per Piece, per cartridge etc."
Pcs	Pieces
Mtr	Meter
Dm	Decimeter
Ct	Cartridge
RI	Roll
AI	Aerosol
Tb	Tube
	USED SHORT FORMS IN FASTENERS
BH	Button Head
BNP	Brass Nickel Plated
CRPH	Cross Recess Pan Head
NP	Nickel Plated
SPH	Slotted Pan Head
SS	Stainless Steel
ZP	Zinc Plated

INTERNAL CONDENSER

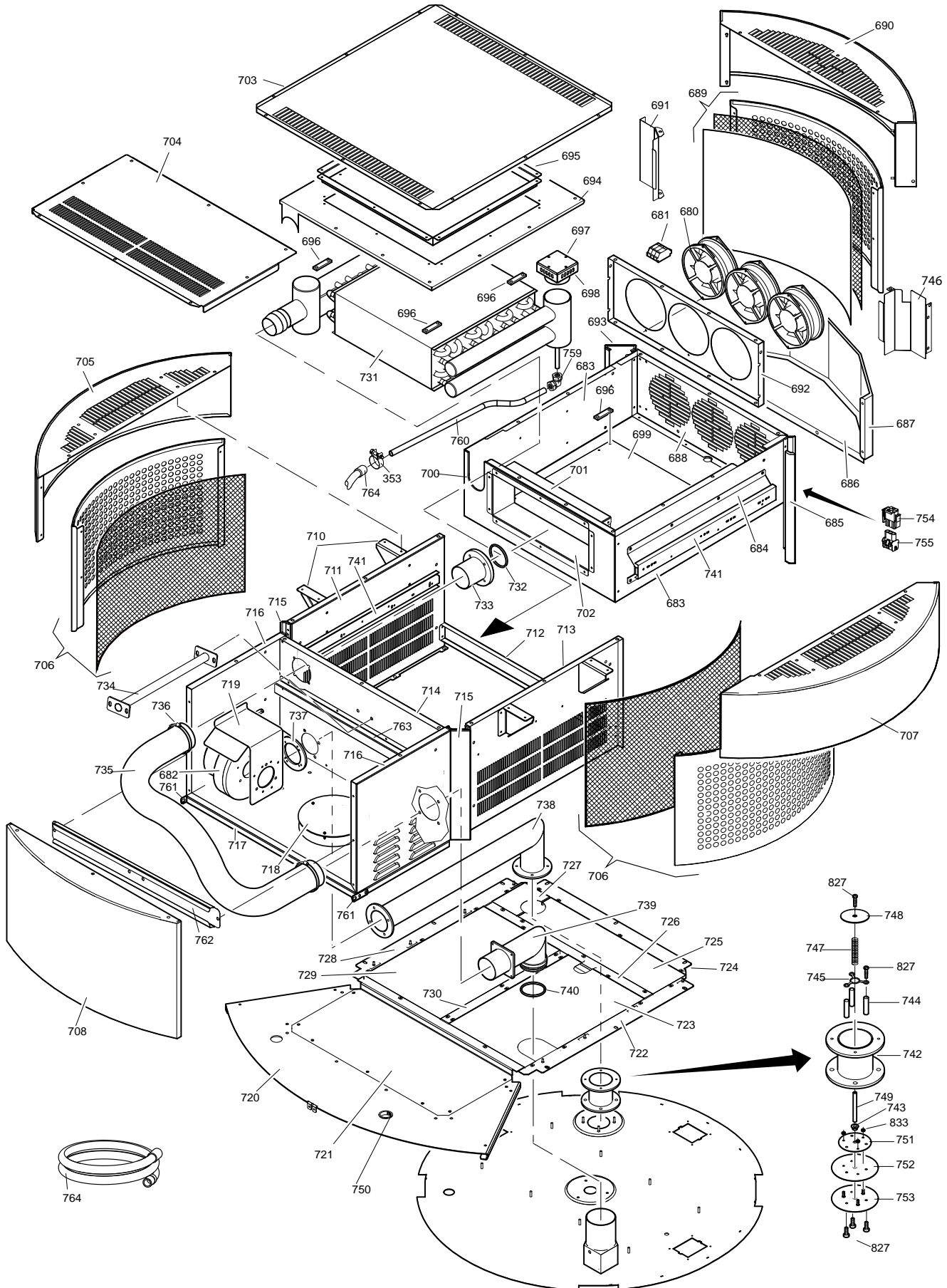

Pos	Part nr	Qty	Unit	Description
680	9221001	3	Pcs	Axial flow ventilator
681	8072070	1	Pcs	Terminal block 3 pole
682	9191280	1	Pcs	Radial flow ventilator 115V 60 HZ
683	9194758	1	Pcs	Condenser box
684	9194767	2	Pcs	Bracket for telescopic slide
685	9194756	1	Pcs	Front post L
686	9194794	1	Pcs	Bottom, air inlet
687	9194793	1	Pcs	Front, air inlet
688	9194791	1	Pcs	Front condenser box
689	9194766	1	Pcs	Lower styling plate, front side
690	9190538	1	Pcs	Upper styling plate, front side
691	9194779	1	Pcs	Air guide condenser box
692	9194759	1	Pcs	Mounting plate axial ventilators
693	9194784	1	Pcs	Front post R
694	9194762	1	Pcs	Cover condenser box, outer
695	9194761	1	Pcs	Cover condenser box, middle
696	9194781	8	Pcs	Positioning cam heat exchanger
697	9194818	1	Pcs	Cover from ventilating cap
698	9190549	1	Pcs	Ventilating cap
699	9194760	1	Pcs	Support heat exchanger
700	9194792	1	Pcs	Backplate condenser box
701	9194796	1	Pcs	Upper air outlet guide
702	9194795	1	Pcs	Lower air outlet guide
703	9194764	1	Pcs	Top plate, middle
704	9194763	1	Pcs	Top plate, back
705	9190537	1	Pcs	Upper styling plate, right hand side
706	9194765	2	Pcs	Lower styling plate, left and right side
707	9190536	1	Pcs	Upper styling plate, left side
708	9190539	1	Pcs	Back plate
710	9194773	4	Pcs	Bracket styling plates
711	9194753	1	Pcs	Side plate R
712	9194754	1	Pcs	Construction profile
713	9194752	1	Pcs	Side plate L
714	9194785	1	Pcs	Separation panel
715	9194755	2	Pcs	Back post
716	9190551	1	Pcs	Ventilator compartment.
717	9194737	1	Pcs	Construction profile backside
718	9194857	1	Pcs	Cover plate service shutter
719	9194823	1	Pcs	Cover, radial flow ventilator
720	9194736	1	Pcs	Top plate back side
721	9194738	1	Pcs	Construction profile
722	9194739	1	Pcs	Construction profile L for covers
723	9194744	1	Pcs	Cover L
724	9194741	1	Pcs	Construction profile front side for covers
725	9194746	1	Pcs	Cover frontside L
726	9194742	1	Pcs	Cross-beam

Pos	Part nr	Qty	Unit	Description
727	9194747	1	Pcs	Cover frontside R
728	9194740	1	Pcs	Construction profile R for covers
729	9194745	1	Pcs	Cover R
730	9194743	1	Pcs	Longitudinal beam
731	9190174	1	Pcs	Ass. Heat exchanger
732	9191278	1	Pcs	O-ring inside, 53,34x 5,33
733	9190541	1	Pcs	Sliding bush
734	9190540	1	Pcs	Bracket, vapor hose
735	9191281	1	Pcs	Hose, Ø63 inside reinforced silicon
736	0156827	2	Pcs	Hose clamp, 68-85 mm ZP
737	9194776	1	Pcs	Mounting ring, radial flow ventilator
738	9190535	1	Pcs	Blast air pipe
739	9190542	1	Pcs	Air outlet knee.
740	9191279	1	Pcs	O-ring outside, 62,87 x 5,33
741	9281020	1	Pcs	Teleopic slide
742	9190543	1	Pcs	Body non-return valve
743	9191085	1	Pcs	Bearing 6 mm
744	9193120	3	Pcs	Distance bush, M4x30
745	9194819	1	Pcs	Triple spacer
746	9194780	1	Pcs	Cover plate front left, condensor
747	9191277	1	Pcs	Spring 0,63x8x55
748	9194846	1	Pcs	Disc air inlet cold
749	9193119	1	Pcs	Distance bush, M4x52
750	9171015	1	Pcs	Grommet feedthrough
751	9194732	1	Pcs	Locking plate, gasket non return valve
752	9192335	1	Pcs	Silicon gasket
753	9194731	1	Pcs	Base plate, gasket non return valve
754	6501444	1	Pcs	Cap housing M-N-L 3-pole
755	6501445	1	Pcs	Plug housing M-N-L 3-pole
756	3500049	1	Pcs	Tube, silicon red 9,5x16
757	9192039	6	Pcs	Hose clamp 13-20 mm
758	9192038	8	Pcs	T-piece 10 mm plastic
759	9191293	1	Pcs	Elbow compression 22mm (F-F)
760	9193148	1	Pcs	Tube D 22mm for condensation drain
761	9194877	2	Pcs	Mounting plate back panel
762	9194876	1	Pcs	Bracket for humidity hose
763	9194843	1	Pcs	Mounting profile for plate condensor
764	3500054	1	Pcs	Hose drain
765	9191251	1	Pcs	Hose Clamp
8xx				See fasteners

RINSE KIT

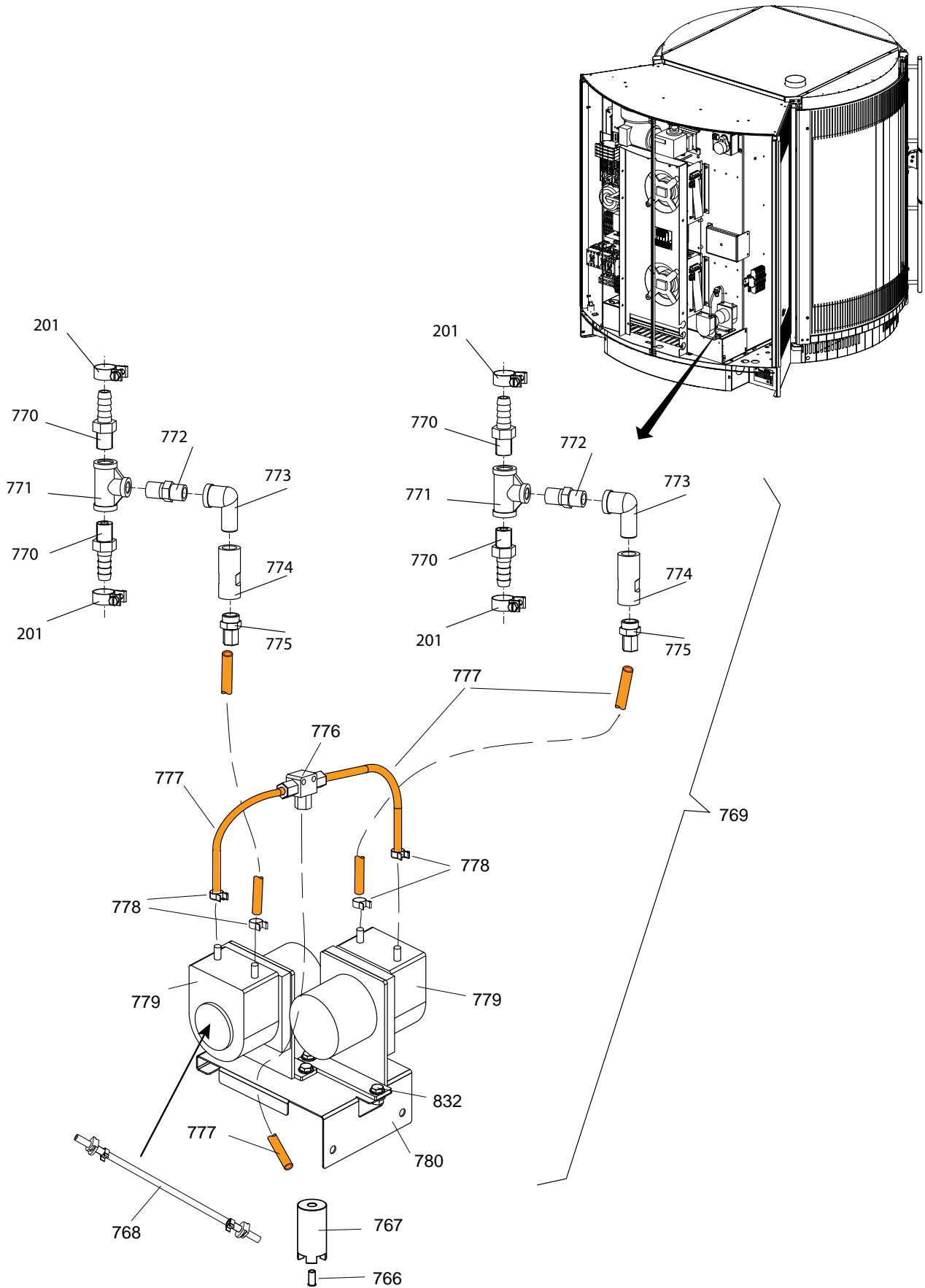

Pos	Part nr	Qty	Unit	Description
201	9191295	4	Pcs	Hose clip, 15-17mm
766	9192395	1	Pcs	Hose immersing weight
767	9191327	1	Pcs	Stiffener sleeve
768	9191325s			Exchange tube (set 2 pcs)
769	9190198s			Rinse kit ass.
770	9301121	4	Pcs	Hose nipple, 1/4" SST
771	3721038	2	Pcs	Tee threaded 1/4"
772	9301022	2	Pcs	Hexagon nipple threaded 1/4"
773	3721037	2	Pcs	Elbow threaded 1/4"
774	9301078	2	Pcs	Valve non return threaded 1/4"
775	9301112	2	Pcs	Plastic nipple push-on 6-4mm
776	9301117	1	Pcs	Tee connector D6/4
777	9301119	2	Mtr	Hose PVC 6x4 mm clear
778	9301120	4	Pcs	Hose clamp 6-8mm SST
779	9301072	2	Pcs	Peristaltic pump 115VAC 50/60Hz
780	9304933	1	Pcs	Mounting plate, pumps

	USED SHORT FORMS
Pos	Position number in drawing
Qty	This column shows the quantity that has been used in a unit.
Unit	This column shows how the part can be bought. Per Meter, per Piece, per cartridge etc."
Pcs	Pieces
Mtr	Meter
Dm	Decimeter
Ct	Cartridge
RI	Roll
AI	Aerosol
Tb	Tube
	USED SHORT FORMS IN FASTENERS
BH	Button Head
BNP	Brass Nickel Plated
CRPH	Cross Recess Pan Head
NP	Nickel Plated
SPH	Slotted Pan Head
SS	Stainless Steel
ZP	Zinc Plated

BAKE

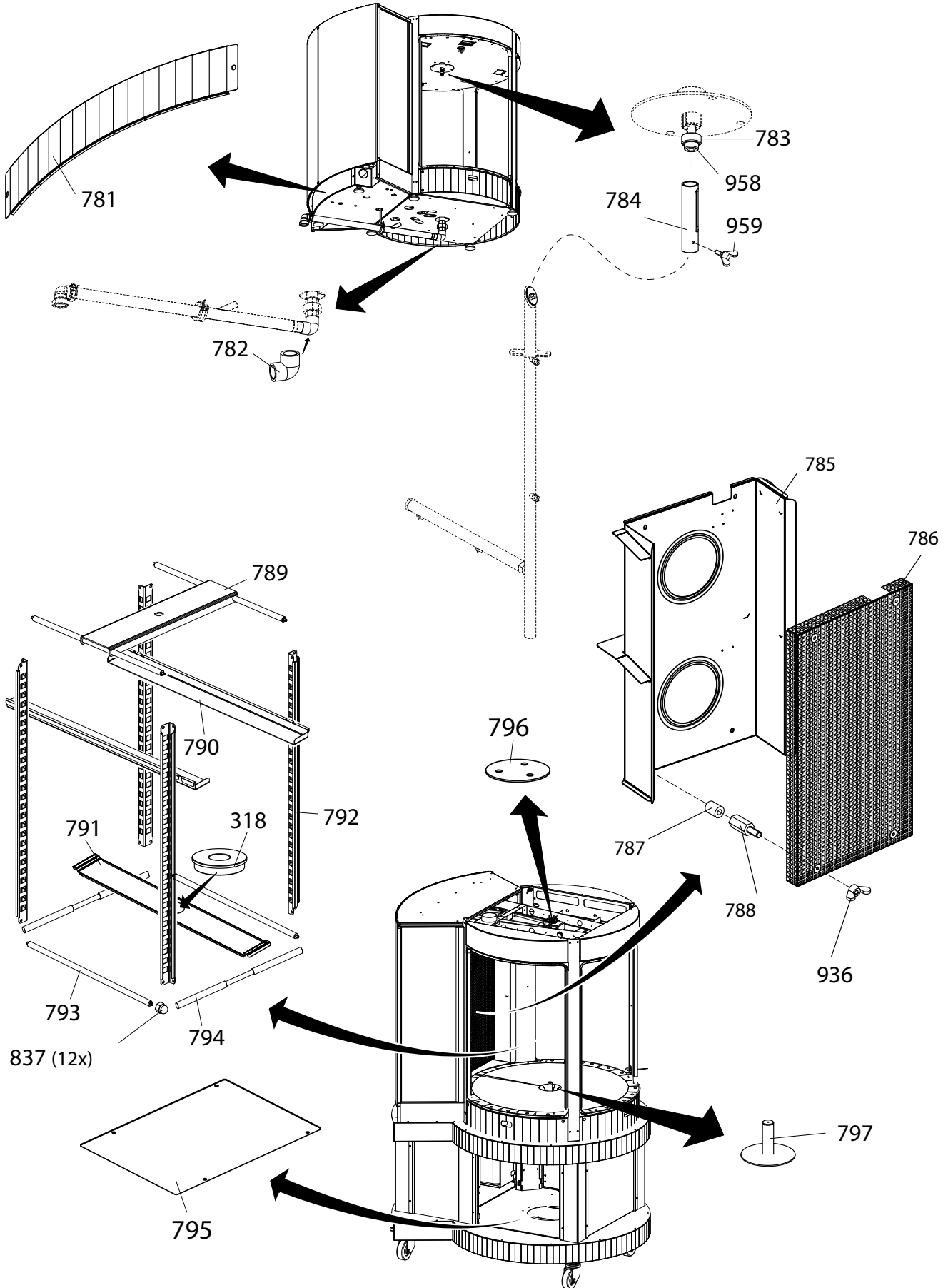

Pos	Part nr	Qty	Unit	Description
318	9192092	1	Pcs	Teflon bearing
781	9194413	1	Pcs	Cover plate back
782	9191113	1	Pcs	Elbow threaded 1"
783	9193092	1	Pcs	Teflon bearing
784	9192162	1	Pcs	Centering tube
785	9190470	1	Pcs	Ass. Panel rear, fan
786	9190507	1	Pcs	Ass. Plate fan
787	9193089	4	Pcs	Spacer, fan plate
788	9193093	4	Pcs	Spacer, M6x23
789	9190415	1	Pcs	Ass. part suspension rack
790	9194058	18	Pcs	Guide, baketray
791	9194416	1	Pcs	Guide profile, baketray
792	9194057	4	Pcs	Stud trayrack
793	9192232	2	Pcs	Connection, baking rack
794	9192210	2	Pcs	Connection D14, baking rack
795	9194859	1	Pcs	Cover plate, bake
796	9194548	1	Pcs	Cover plate, rotor axle
797	9190467	1	Pcs	Ass. Centering shaft / drain plug
8xx				See fasteners

	USED SHORT FORMS
Pos	Position number in drawing
Qty	This column shows the quantity that has been used in a unit.
Unit	This column shows how the part can be bought. Per Meter, per Piece, per cartridge etc."
Pcs	Pieces
Mtr	Meter
Dm	Decimeter
Ct	Cartridge
RI	Roll
AI	Aerosol
Tb	Tube
	USED SHORT FORMS IN FASTENERS
BH	Button Head
BNP	Brass Nickel Plated
CRPH	Cross Recess Pan Head
NP	Nickel Plated
SPH	Slotted Pan Head
SS	Stainless Steel
ZP	Zinc Plated

FASTENERS

Pos	Part nr	Qty	Unit	Description
800	4280107	34	Pcs	Bolt M6x20, ZP
801	4289363	24	Pcs	Lockwasher M6, serrated ZP
802	4288321	16	Pcs	Bolt M5x16, SS socket button head.
803	9194348	50	Pcs	Washer 20x6,4 x2, SS
804	4285092	46	Pcs	Nut M6, black serrated
805	4288232	100	Pcs	Bolt M5x12, SS socket, wide BH
806	4286713	8	Pcs	Bolt M6x16, ZP threadforming
807	4313049	36	Pcs	Turn in Clamp
808	4312352	36	Pcs	Pop rivet 4x8,5, range 4,8
809	4285131	48	Pcs	Rivet nut M6, SS
811	9191107	1	Pcs	Nut M4, SS selflocking
812	9087570	12	Pcs	Nut M5, black serrated
813	3701027	4	Pcs	Rivet 3,2x6,4, SS
814	4289787	12	Pcs	Bolt M6x30 ZP
815	9191103	8	Pcs	Threaded bush M5 x 20
816	0141547	4	Pcs	Nut M8, SS
817	4287549	3	Pcs	Washer M8, ZP
818	9193085	1	Pcs	Studding M8x170
819	0196673	1	Pcs	Bolt M8x25, ZP
820	0141149	12	Pcs	Screw M5x16, SS CRPH
821	9194871	6	Pcs	Washer 16x5,2, 3mm thick
822	0142315	4	Pcs	Nut M5, SS hexagonal
823	9194555	1	Pcs	Washer, hinge pin
824	9191050	6	Pcs	Bolt, SS M5x18
825	0142103	16	Pcs	Washer M5
826	4280218	12	Pcs	Screw M5x45, SS CRPH
827	4280208	12	Pcs	Screw M4x8, SS CRPH
828	4280215	18	Pcs	Screw M5x8, SS CRPH
829	4280558	6	Pcs	Screw M5x16, SS Slotted wide head
830	9192065	9	Pcs	Capnut M4, ZP
831	0142129	15	Pcs	Washer M4, SS
832	4288231	54	Pcs	Bolt M5x10, SS serrated
833	0142307	6	Pcs	Nut M4, SS
834	4311110	12	Pcs	Washer M5, SS Ø15x5mm
835	0142111	16	Pcs	Washer M6, SS
836	4285035	12	Pcs	Nut M6, Brass
837	0195910	4	Pcs	Capnut M6, BNP
838	4285076	1	Pcs	Bolt M8x16, ZP
839	9193043	8	Pcs	Studding M6 x 90
840	9193042	2	Pcs	Studding M6 x 180
841	0147017	4,1	Pcs	Screw M2,5x16, SS Slotted pan head
842	0142293	4	Pcs	Nut M2,5, SS hexagonal

Pos	Part nr	Qty	Unit	Description
843	9191130	4	Pcs	starlock washer, 3mm black
844	0188750	4	Pcs	Nylon Washer 4,3x9x1,4
845	0141079	2	Pcs	Screw M5x35, SS CRPH
846	9191052	2	Pcs	Screw M5x20, SS socket button head
847	9070688	4	Pcs	Bolt M8x12, SS
848	9008518	4	Pcs	Lockwasher, SS serrated
849	0142292	44	Pcs	Nut M3
850	9191045	1	Pcs	Circlip, 30 mm external
851	9194508	1	Pcs	Lock washer M22
852	9192075	1	Pcs	Nut M22 x 1,5, SS
854	0141076	2	Pcs	Screw M3x20, SS CRPH
855	0147015	2	Pcs	Screw M3x35, SS CRPH
856	0141035	2	Pcs	Screw M3x6, SS CRPH
857	0141050	13	Pcs	Screw M3x10, SS CRPH
858	0141075	15	Pcs	Screw M3x16, SS CRPH
859	4312810	1	Pcs	Socket set screw M3x6, SS
860	0143939	6	Pcs	Washer M3, SS
861	4285151	1	Pcs	starlock washer, 6mm
862	9191041	2	Pcs	Circlip, 5mm "E" type (6mm shaft)
863	4287540	17	Pcs	Screw M4x10, BNP
864	4285319	14	Pcs	Screw 4,8x13, ZP Self drilling and tapping.
865	0141080	2	Pcs	Screw M4x6, SS Cross recess pan head
866	4287620	6	Pcs	Screw 4,2x12, NP self tapping
867	0141107	4	Pcs	Screw M4x20, SS Cross recess pan head
868	4285078	4	Pcs	Nut 1/4" bsw ZP
869	0147064	2	Pcs	Screw M4x10, SS slotted pan head
870	4286527	2	Pcs	Screw 3,5x19, SS selftapping CRPH
871	9191049	3	Pcs	Set screw M5x5, black
872	4285010	4	Pcs	Nut M3, ZP with lockwasher
873	3701248	4	Pcs	Spacer 7mm, Ø3,2x6 NP
874	0149296	4	Pcs	Spacer 10mm, Ø4,2x8 Nylon
875	9057347	14	Pcs	Spacer 10mm, Ø5,2x10 Nylon
876	0141165	2	Pcs	Screw M5x25, SS CRPH
877	4285135	20	Pcs	Bolt M5x10, ZP thread forming
878	0137344	4	Pcs	Screw M5x30, SS CRPH
879	4287610	9	Pcs	Screw 3,5x13, ZP selftapping CRPH
880	9193083	6	Pcs	Studding M10x50
881	4287557	6	Pcs	Washer M10, ZP
882	4285050	6	Pcs	Nut M10, ZP
883	9008047	5	Pcs	Nut M8, ZP self locking

Pos	Part nr	Qty	Unit	Description
884	0141238	16	Pcs	Bolt M6x16, SS
892	141521	4	Pcs	Nut M6, SS
896	4285408	24		Capnut M5, BNP
929	197378	4	Pcs	Washer M12, ZP
930	9008056	4	Pcs	Nut M12, ZP
936	9073149	1	Pcs	Wingnut M6, SS
937	2800082		Pcs	Wingnut M6, ZP
939	4312027	4	Pcs	Connection nut M5x15, ZP
951	8071043	4	Pcs	Nut M4, Serrated ZP
954	4285084	4	Pcs	Bolt, self drilling
958	195783	1	Pcs	Screw M10x30 sock button head
959	9191108	2	Pcs	Wing nut M6x10 SS
960	141204	4	Pcs	Screw M4x16, Pan head SS
961	149210	56	Pcs	Screw M5x6, Pan head
962	141539	4	Pcs	Screw M5x10, SS countersunk

MISCELLANIOUS			
Part nr	Qty	Unit	Description
9192331	12	Pcs	Chicken rack 1,7 kg RVS
9191136	1	Pcs	Pipe brush
9191146	1	Pcs	Pipe brush little
9190073			Handle lock
9191244s			Turbine puller
9191175			Grease bag 10 Ltr (box of 200st)
9191284			Cleaning fluid 4x 1GL
0194935		Tb	Loctite 620, 50ml
0194938		Tb	Loctite 648, 50ml
9191234		Pcs	Sealant, 2 component
3500306		Ct	Sealant silicon red 343°C / 650°F
4302335		Ct	Sealant silicon, aluminum 230°C / 450°F
4302375		Ct	Sealant silicon, black 200°C / 400°F
9061045		Al	Silicon spray Eurogrill 0,4ltr
9191109		Ct	Lubricant OKS 250Moly P1900 - 400 gr.
9191235		RI	Foam tape, thick 2mm, wide 9mm
9171128		RI	Velcro (contra hook)
9171127		RI	Velcro (hook)
9192071	2		Washer 10x14mm, copper
9110103	0,5	Pcs	Isolation plate Conlit, 1800x900x15mm
9004718	2,8	Pcs	Isolation plate type 520, 1000x600x22mm
9123517	1	Pcs	Wiring instruction plate Multisserie
9123523	1	Pcs	Sticker Backflow USA
3500105	2	Mtr	Sticker caution electricity (yellow)
9110111	6	Pcs	Sticker caution hot
9123506	1	Pcs	Sticker clearance 6 inch, sides and rear.
9123148	3	Pcs	Sticker high temperature
9123516	1	Pcs	Sticker ON-OFF USA
9110860	1	Pcs	Sticker ventilator
9123389		Pcs	Sticker Warning California
9123484	3	Pcs	Sticker warning replacing lamps
9123456	1	Pcs	Sticker Warning secure to building
9123672	2	Pcs	Sticker Warning USA
9123527	1	Pcs	Sticker, place cleaner
9123817	1	Pcs	Storyboard grease bag DMU Letter US
9123538	2	Pcs	Storyboard Multisserie USA

Part nr	Qty	Unit	Description
9123823	1	Pcs	Storyboard soap DMU 21x7.5 USA
9123537	1	Pcs	Training guide Multiserie USA
9123828	1	Pcs	User manual USA Multiserie
9261022	1	Pcs	Cable gland M25
9261023	1	Pcs	Nut, cable gland M25
9194529	1	Pcs	Lasercut Ampère Sign, Multiserie USA
9191255	1	Pcs	Earth sign
9192269	1	Pcs	Earth strip
9079137		Mtr	Wire AWG 12, black
9079140		Mtr	Wire AWG 12, green/yellow
9070654		Mtr	Wire AWG14, black
0260155		Pcs	Wire AWG18, black
2005933		RI	Ringterminal, M4 red
2005755		Pcs	Ringterminal, M4 Blue
2006159		Pcs	Ringterminal M4, uninsulated
2005941		Pcs	Ringterminal, M5 Red
2005763		Pcs	Ringterminal, M5 Blue
2006133		Pcs	Receptacle, female Blue
2006183		Pcs	Receptacle, female Red, full insulated
2006222		Pcs	Receptacle, female Red piggyback
4310570		RI	Receptacle, uninsulated (6000)
8031502		Pcs	Receptacle insulation boot, 6,3x0,9
2005967		Pcs	Splice, Red
2005802		Pcs	Splice, blue
2006303		Pcs	Bootlace ferrule, Grey 0,75 qmm
2005658		Pcs	Bootlace ferrule, Blue 9mm
6511553	0,25	Mtr	Cable protection sleeve
9191187		RI	Spiral protecting conduit Ø6.4mm
9191211		RI	Spiral protecting conduit Ø8mm
2008614	15	Pcs	Sokkel, cable tie
9190072	1	Pcs	Crate set multiserie on underframe
9194504	2	Pcs	U-profiel tbv vlonder
9193144	2	Pcs	Support plank, underframe Front/Rear
9193145	2	Pcs	Support plank, underframe L/R
4288189	4	Pcs	Bolt M8x80, ZP
9008047	5	Pcs	Nut M8, ZP self locking
9193091	3	Pcs	Lock bushing for transport
9191116	2	Pcs	Cap, 3/4" pvc

EMPTY PAGE

CIRCUIT DIAGRAM 2OF 2 UNTILL 2015

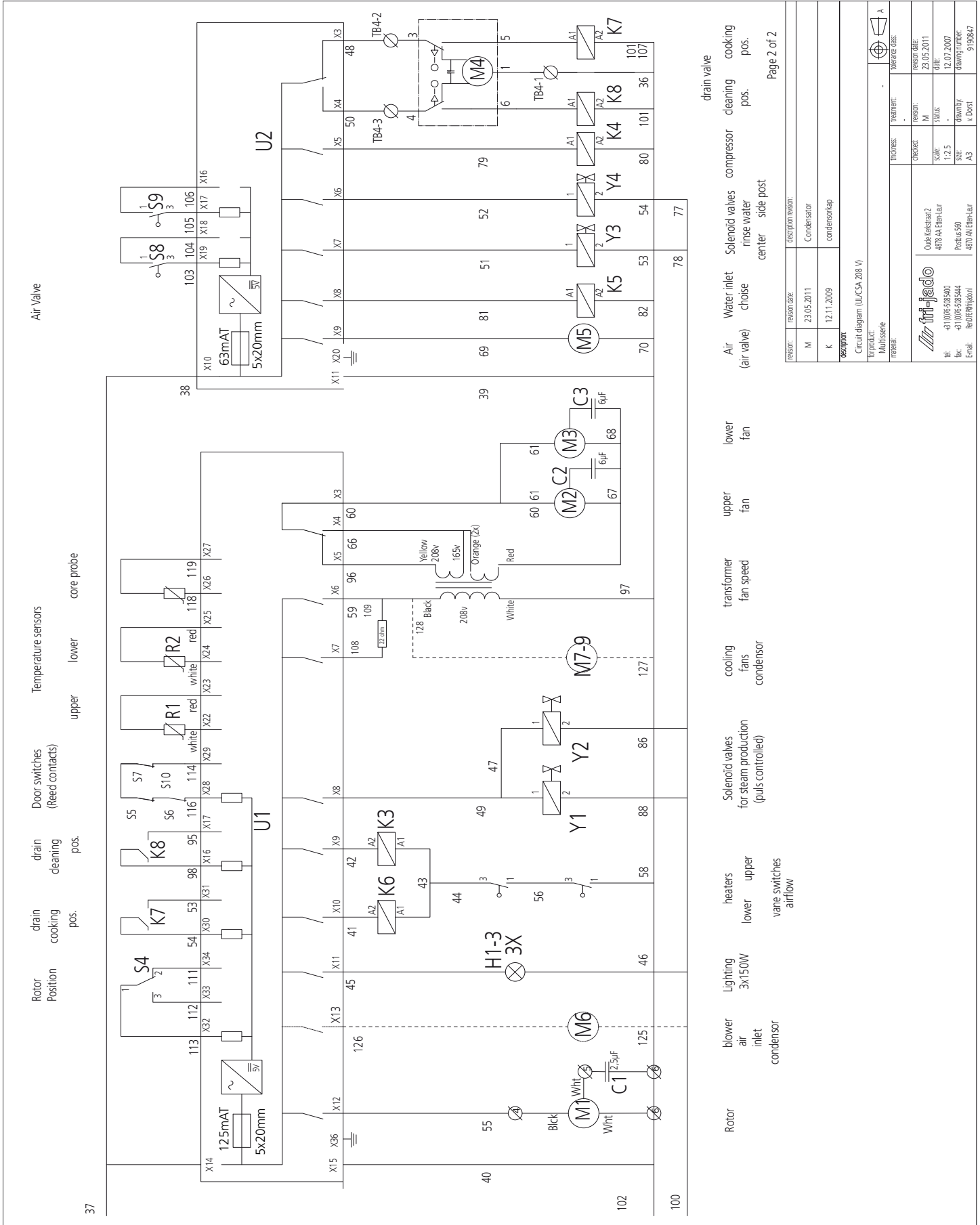

- rotor
- blower
- lighting
- heaters
- solenoid valves for steam production (puls controlled)
- cooling fans
- transformer
- upper fan
- lower fan
- air (air valve)
- water inlet
- solenoid valves
- rinse water
- compressor
- cleaning pos.
- cooking pos.
- drain valve

revision	reason date	description reason
M	23.05.2011	Condensator
K	12.11.2009	condensorkap

description		thickness	treatment	reference case
Circuit diagram (UL/CSA 208 V)				
type product: Multiserie				
material:				
Ad: +1 010 938 5400 Fax: +1 010 938 5444 Email: fri-jado@fri-jado.com				
Oude Kerkstraat 2 4898 AA Ethen-Lar Postbus 560 4870 AA Ethen-Lar				
reason	date	revision	reason	reason date
OK	12.11.2009	OK	M	23.05.2011
size	1:2.5	scale	status	date
A3		A3		12.07.2007
			drawing number	
			v. Doort	9195847

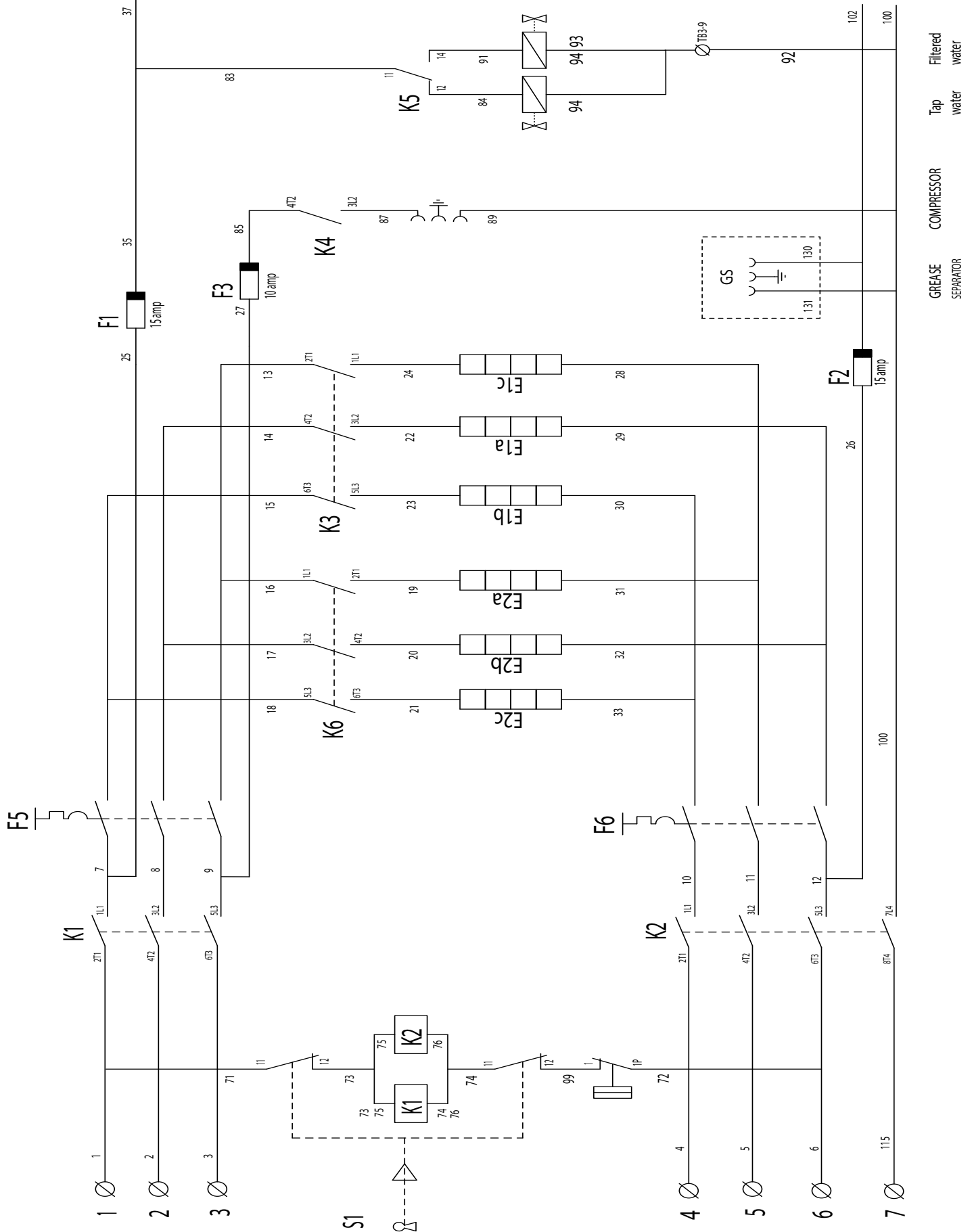
CIRCUIT DIAGRAM 1OF 2 FROM 2016

WIRING DIAGRAM 2OF 2 FROM 2016

USE ONLY THE UPPER AND LOWER CONNECTIONS ON THE SWITCHES

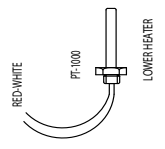
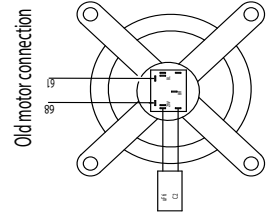
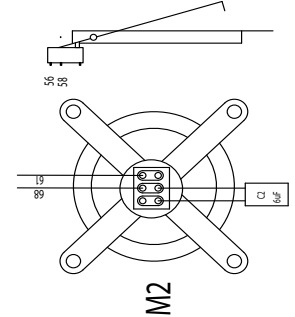
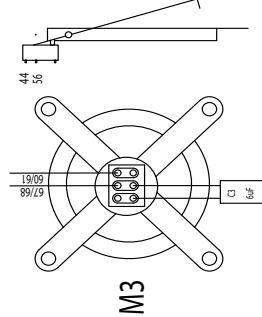
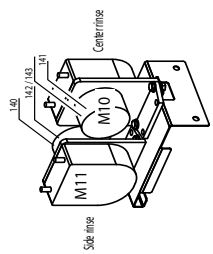
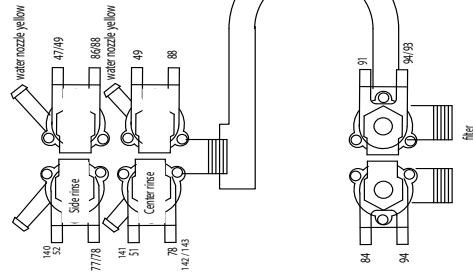
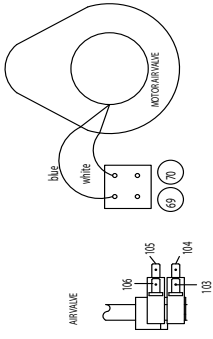
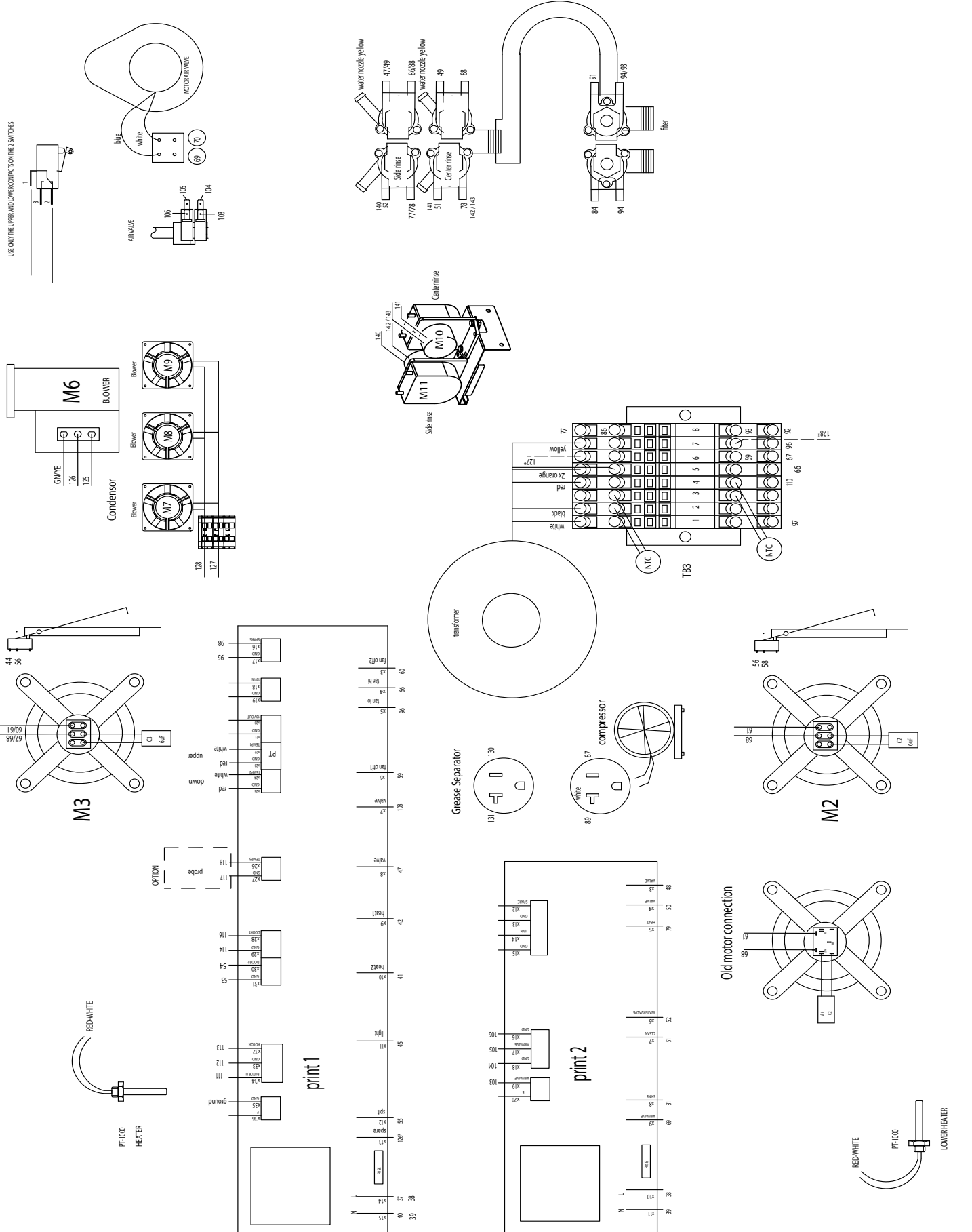

For technical support call: +1 877 374 5236



Fri-Jado Inc. • 1401 Davey Road • Suite 100 • Woodridge IL 60517 • USA • fax +1 630 689 1424
• us.info@frijado.com • www.frijado.com • USA • toll free 877-FRI-JADO