

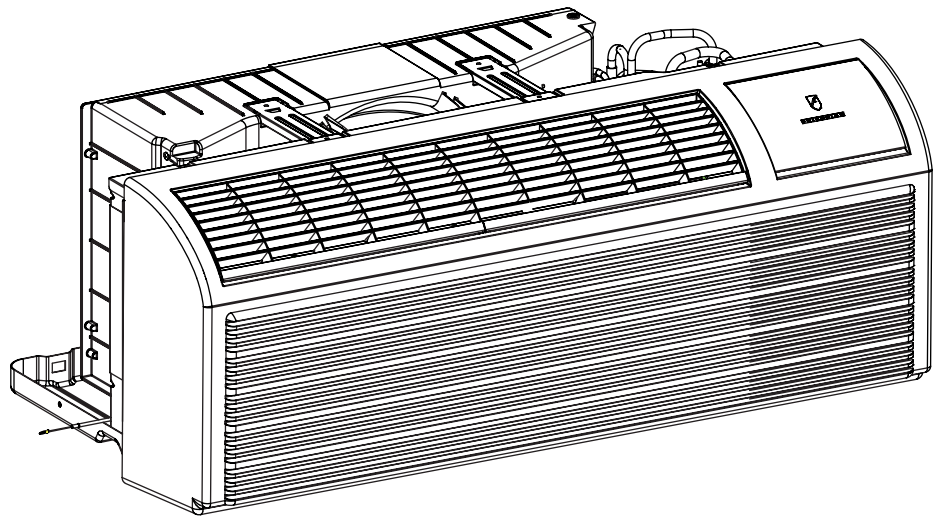

# FRIEDRICH

## PTAC

### ZONEAIRE® SELECT



## Standard Chassis Models

---

**7K** PZE07K3SB  
PZH07K3SB

---

**9K** PZE09K3SB, PZE09R3SB  
PZH09K3SB, PZH09R3SB

---

**12K** PZE12K3SB, PZE12R3SB  
PZH12K3SB, PZH12R3SB

---

**15K** PZE15K5SB  
PZH15K5SB

---

---

# TABLE OF CONTENTS

INTRODUCTION	4
Important Safety Information	4
Personal Injury Or Death Hazards	5
Operation of Equipment in During Construction	7
Model Number Reference Guide	8
Serial Number Reference Guide	9
Product Features	10
SPECIFICATIONS	12
General Specifications 7-9k Electric Heat	12
General Specifications 7-9k Heat Pump Models	13
General Specifications 12-15k Electric Heat	14
General Specifications 12-15k Heat Pump	15
Electrical Data	17
OPERATION	20
Function and Control	20
Refrigeration Sequence Of Operation	25
Refrigerant System Diagram	26
Routine Maintenance	27
INSTALLATION	28
PTAC Installation Recommendations	28
Wall Sleeve Installation Instructions (PDXWS)	29
Alternate Wall Installations	30
PXDR10 Drain Kit Installation	33
External Drain	34
PXGA Standard Grille	35
Chassis Install Preparation	36
Chassis Installation	38
How To Connect	39
Final Inspection & Start-up Checklist	40
R-410A SEALED SYSTEM REPAIR	41
Refrigerant Charging	42
Undercharged Refrigerant Systems	43
Overcharged Refrigerant Systems	44
Restricted Refrigerant System	45
Sealed System Method of Charging/ Repairs	46
COMPONENT TESTING	47
Hermetic Components Check	47
Reversing Valve Description And Operation	48
Testing The Reversing Valve Solenoid Coil	49
Checking The Reversing Valve	50
Touch Test Chart : To Service Reversing Valves	52
Compressor Checks	53
Compressor Replacement -Special Procedure in Case of Compressor Burnout	56
TROUBLESHOOTING	57
Basic Troubleshooting	57
Malfunction Analysis	59
Unit Lost Power	62
Control Panel Does Not Work	63
Malfunction of Temperature Sensor	64
E4 Function Error	65
E8 Function Error	66
E9 Function Error	68
Electric Heater Not Running	73
Electric Heater Not Running	74
WIRING DIAGRAMS	75
7K Cool+ Electric Heat 230 V	75
9K Cool+ Electric Heat 230v and 265v	76
12K Cool+ Electric Heat 230v and 265v	77
15K Cool+ Electric Heat 230v	78

---

# TABLE OF CONTENTS

7K Cool+ Heat Pump 230v	79
9K Cool+ Heat Pump 230v and 265v	80
12K Cool+ Heat Pump 230v and 265v	81
15K Cool+ Heat Pump 230v	82
PARTS CATALOG	83
PZE07K3SB, PZE09K3SB, PZE09R3SB, PZE12K3SB, PZE12R3SB, PZE15K3SB	84
PZH07K3SB, PZH09K3SB, PZH09R3SB, PZH12K3SB, PZH12R3SB, PZH15K3SB	89
ACCESSORIES	93
APPENDIX	95
Reference Sheet of Celsius and Fahrenheit	95
Resistance Table of THERMISTORS (5K)	96
WARRANTY	98
FRIEDRICH AUTHORIZED PARTS DEPOTS	99

# INTRODUCTION

## Important Safety Information

The information in this manual is intended for use by a qualified technician who is familiar with the safety procedures required for installation and repair, and who is equipped with the proper tools and test instruments required to service this product.

Installation or repairs made by unqualified persons can result in subjecting the unqualified person making such repairs as well as the persons being served by the equipment to hazards resulting in injury or electrical shock which can be serious or even fatal.

Safety warnings have been placed throughout this manual to alert you to potential hazards that may be encountered. If you install or perform service on equipment, it is your responsibility to read and obey these warnings to guard against any bodily injury or property damage which may result to you or others.

### Your safety and the safety of others is very important.

We have provided many important safety messages in this manual and on your appliance. Always read and obey all safety messages.



This is a safety Alert symbol. This symbol alerts you to potential hazards that can kill or hurt you and others. All safety messages will tell you what the potential hazard is, tell you how to reduce the chance of injury, and tell you what will happen if the instructions are not followed. All safety messages will follow the safety alert symbol with the word "WARNING" or "CAUTION". These words mean:



**WARNING**

Indicates a hazard which, if not avoided, can result in severe personal injury or death and damage to product or other property.



**CAUTION**

Indicates a hazard which, if not avoided, can result in personal injury and damage to product or other property.

**NOTICE**

Indicates property damage can occur if instructions are not followed.



**WARNING**

#### Refrigeration system under high pressure



Do not puncture, heat, expose to flame or incinerate.

Only certified refrigeration technicians should service this equipment.

R410A systems operate at higher pressures than R22 equipment. Appropriate safe service and handling practices must be used.

Only use gauge sets designed for use with R410A.

Do not use standard R22 gauge sets.

# INTRODUCTION

## Personal Injury Or Death Hazards

SAFETY FIRST	⚠ WARNING	⚠ AVERTISSE- MENT	⚠ ADVERTEN- CIA
	Do not remove, disable or bypass this unit's safety devices. Doing so may cause fire, injuries, or death.	Ne pas supprimer, désactiver ou contourner cette l'unité des dispositifs de sécurité, faire vous risqueriez de provoquer le feu, les blessures ou la mort.	No eliminar, desactivar o pasar por alto los dispositivos de seguridad de la unidad. Si lo hace podría producirse fuego, lesiones o muerte.

### ELECTRICAL HAZARDS:

- Unplug and/or disconnect all electrical power to the unit before performing inspections, maintenance, or service.
- Make sure to follow proper lockout/tag out procedures.
- Always work in the company of a qualified assistant if possible.
- Capacitors, even when disconnected from the electrical power source, retain an electrical charge potential capable of causing electric shock or electrocution.
- Handle, discharge, and test capacitors according to safe, established, standards, and approved procedures.
- Extreme care, proper judgment, and safety procedures must be exercised if it becomes necessary to test or troubleshoot equipment with the power on to the unit.
- Do not spray water on the air conditioning unit while the power is on.
- Electrical component malfunction caused by water could result in electric shock or other electrically unsafe conditions when the power is restored and the unit is turned on, even after the exterior is dry.
- Use air conditioner on a single dedicated circuit within the specified amperage rating.
- Use on a properly grounded outlet only.
- Do not cut or modify the power supply cord or remove the ground prong of the plug.
- Never operate the unit on an extension cord.
- Follow all safety precautions and use proper and adequate protective safety aids such as: gloves, goggles, clothing, properly insulated tools, and testing equipment etc.
- Failure to follow proper safety procedures and/or these warnings can result in serious injury or death.

---

# INTRODUCTION

## Personal Injury Or Death Hazards

- **REFRIGERATION SYSTEM REPAIR HAZARDS:**

- Use approved standard refrigerant recovering procedures and equipment to relieve high pressure before opening system for repair.
- Do not allow liquid refrigerant to contact skin. Direct contact with liquid refrigerant can result in minor to moderate injury.
- Be extremely careful when using an oxy-acetylene torch. Direct contact with the torch's flame or hot surfaces can cause serious burns.
- Make certain to protect personal and surrounding property with fire proof materials and have a fire extinguisher at hand while using a torch.
- Provide adequate ventilation to vent off toxic fumes, and work with a qualified assistant whenever possible.
- Always use a pressure regulator when using dry nitrogen to test the sealed refrigeration system for leaks, flushing etc.

- **MECHANICAL HAZARDS:**

- Extreme care, proper judgment and all safety procedures must be followed when testing, troubleshooting, handling, or working around unit with moving and/or rotating parts.
- Be careful when, handling and working around exposed edges and corners of the sleeve, chassis, and other unit components especially the sharp fins of the indoor and outdoor coils.
- Use proper and adequate protective aids such as: gloves, clothing, safety glasses etc.
- Failure to follow proper safety procedures and/or these warnings can result in serious injury or death.

- **PROPERTY DAMAGE HAZARDS**

- **FIRE DAMAGE HAZARDS:**

- Read the Installation/Operation Manual for the air conditioning unit prior to operating.
- Use air conditioner on a single dedicated circuit within the specified amperage rating.
- Connect to a properly grounded outlet only.
- Do not remove ground prong of plug.
- Do not cut or modify the power supply cord.
- Do not use extension cords with the unit.
- Be extremely careful when using acetylene torch and protect surrounding property.
- Failure to follow these instructions can result in fire and minor to serious property damage.

- **WATER DAMAGE HAZARDS:**

- Improper installation, maintenance or servicing of the air conditioner unit can result in water damage to personal items or property.
- Insure that the unit has a sufficient pitch to the outside to allow water to drain from the unit.
- Do not drill holes in the bottom of the drain pan or the underside of the unit.
- Failure to follow these instructions can result in damage to the unit and/or minor to serious property damage.

---

# INTRODUCTION

## Operation of Equipment in During Construction

- **OPERATION OF EQUIPMENT MUST BE AVOIDED DURING CONSTRUCTION PHASES WHICH WILL PRODUCE AIRBORNE DUST OR CONTAMINATES NEAR OR AROUND AIR INTAKE OPENINGS:**
- Wood or metal framing;
- Drywalling or sheathing,
- Spackling or applying joint compound.
- Sanding or grinding.
- Moulding or trimwork.

### ***NOTICE***

Operating the equipment during any phase of active construction noted above can void the equipment's warranty, also leading to poor performance and premature failure

# INTRODUCTION

This service manual is designed to be used in conjunction with the installation and operation manuals provided with each air conditioning system.

This service manual was written to assist the professional service technician to quickly and accurately diagnose and repair malfunctions.

Installation procedures are not given in this manual. They are given in the Installation and Operation Manual which can be acquired on the Friedrich [website \(www.friedrich.com\)](http://www.friedrich.com).

## Model Number Reference Guide

PTAC/PTHP Model Identification Guide							
<b>MODEL NUMBER</b>	<b>PZ</b>	<b>H</b>	<b>07</b>	<b>K</b>	<b>3</b>	<b>S</b>	<b>B</b>
Series PZ = Friedrich Digital PTAC	System E = Cooling with electric heat H = Heat Pump with Auxiliary Heat		Nominal Capacity 07 = 7,000 Btuh    12 = 12,000 Btuh 09 = 9,000 Btuh    15 = 15,000 Btuh		Voltage K = 230/208V - 1 Ph. - 60 Hz. R = 265V - 1 Ph. - 60 Hz.		Engineering Digit
						Design Series	
						Chassis S = Standard	
						Nominal Heater Size (230V or 265V) 3 = 3 KW * 5.0 kw only available on 15,000 BTU models	

**IMPORTANT:** It will be necessary for you to accurately identify the unit you are servicing, so you can be certain of a proper diagnosis and repair.

**Figure 103**

# INTRODUCTION

## Serial Number Reference Guide

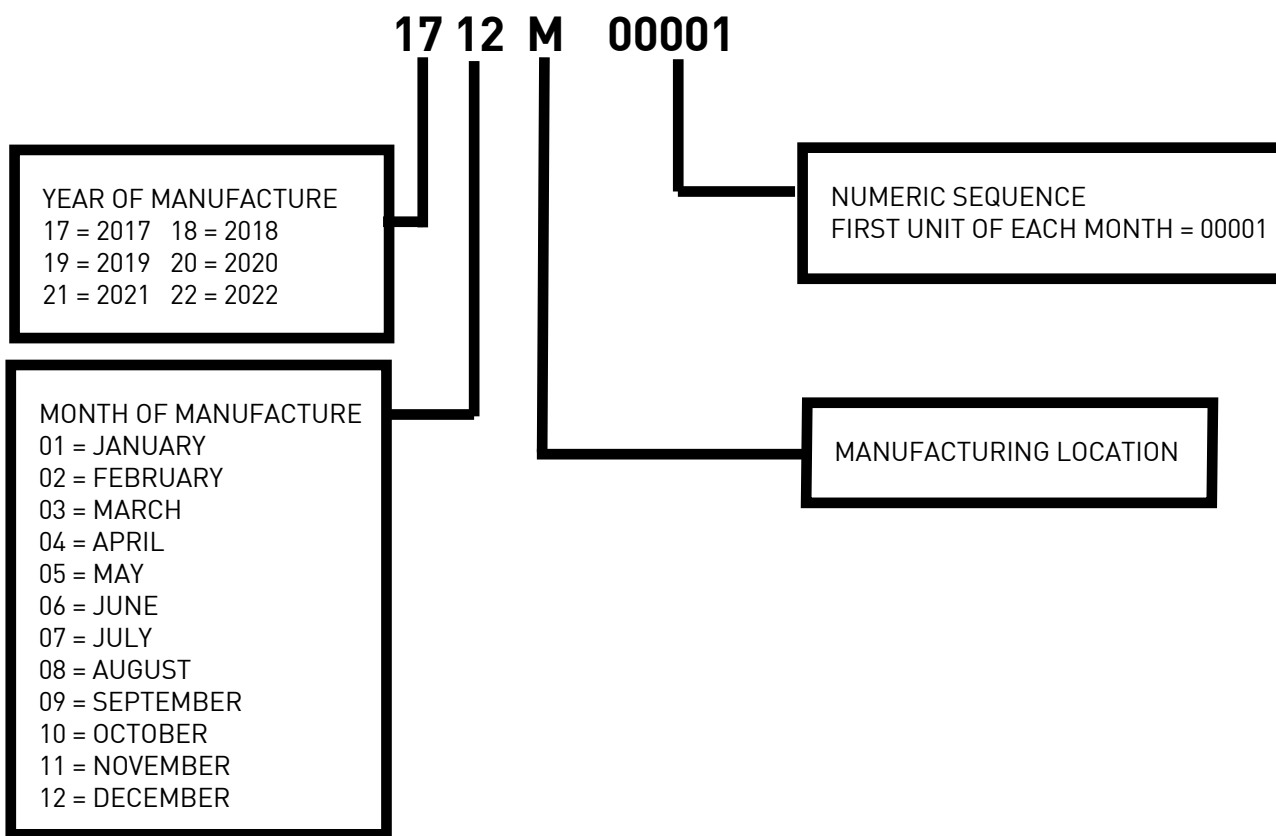

Refer to the Chart below for Serial Numbers beginning with an Alpha Sequence

PTAC Serial Number Identification Guide				
<b>SERIAL NUMBER</b>	<b>A</b>	<b>K</b>	<b>A</b>	<b>M</b>
<b>YEAR MANUFACTURED</b> LJ = 2009 AE = 2015 AK = 2010 AF = 2016 AA = 2011 AG = 2017 AB = 2012 AC = 2013 AD = 2014				<b>00001</b> <b>PRODUCTION RUN NUMBER</b>
<b>MONTH MANUFACTURED</b> A = Jan D = Apr G = Jul K = Oct B = Feb E = May H = Aug L = Nov C = Mar F = Jun J = Sep M = Dec				<b>PRODUCT LINE</b> M = PRODUCT CODE

Figure 104

---

# INTRODUCTION

## Product Features

The new Friedrich digital PTAC has state of the art features to improve guest comfort, indoor air quality and conserve energy. Through the use of specifically designed control software for the PTAC industry Friedrich has accomplished what other Manufacturer's have only attempted – a quiet, dependable, affordable and easy to use PTAC.

Below is a list of standard features on every Friedrich PTAC and their benefit to the owner.

---

DIGITAL TEMPERATURE READOUT	By digitally monitoring the desired room temperature, the room is controlled more precisely than conventional systems. The large, easy-to-read LED display can show either the set point or actual room temperature as selected by owner.
INDIVIDUAL MODE & FAN CONTROL BUTTONS	By having separate control buttons and indicators for both fan and mode settings, the Friedrich digital control eliminates the confusion of previous digital PTACs. The accurate temperature setting provides greater guest comfort than other systems.
QUIET START/STOP FAN DELAY	The fan start and stop delays prevent abrupt changes in room acoustics due to the compressor energizing or stopping immediately. Upon call for cooling or heating, the unit fan will run for five seconds prior to energizing the compressor. Also, the fan-off delay allows for “free cooling” by utilizing the already cool indoor coil to its maximum capacity by running for 30 seconds after the compressor.
REMOTE THERMOSTAT OPERATION	Some applications require the use of a wall-mounted thermostat. All new Friedrich PTACs may be switched from unit control to remote thermostat control easily without the need to order a special model or accessory kit.
INTERNAL DIAGNOSTIC PROGRAM	The Friedrich digital PTAC features a self-diagnostic program that can alert maintenance to component failures or operating problems. The internal diagnostic program saves properties valuable time when diagnosing running problems.
FACTORY RUN-TEST	Factory run-tested units reduce problems in the field.
ELECTRONIC TEMPERATURE LIMITING	By limiting the operating range, the property can save energy by eliminating “max cool” or “max heat” situations common with older uncontrolled systems. The new electronic control allows owners to set operating ranges for both heating and cooling independently of one another.
ROOM FREEZE PROTECTION	When the PTAC senses that the indoor room temperature has fallen to 50°F, the unit will cycle on the fan (high) and the electric strip heat to raise the room temperature to 55°F, and then cycle off again. This feature works regardless of the mode selected and can be turned off.
RANDOM COMPRESSOR RESTART	Multiple compressors starting at once can often cause electrical overloads and premature unit failure. The random restart delay eliminates multiple units from starting at once following a power outage or initial power up. The compressor delay will range from 120 to 240 seconds.
CONDENSATE REMOVAL SYSTEM	Condenser fan utilizes slinger ring technology to pick up condensate from the base pan and disperse it on to the condenser coil where it evaporates. This helps to cool the coil and increase the energy efficiency of the unit.

---

---

# INTRODUCTION

## Product Features

---

DIGITAL DEFROST THERMOSTAT	The PZ-Series uses a digital thermostat to accurately monitor the outdoor coil conditions to allow the heat pump to run whenever conditions are correct. Running the PTAC in heat pump mode saves energy and reduces operating costs. The digital thermostat allows maximization of heat pump run time.
INSTANT HEAT HEAT PUMP MODE	Heat pump models will automatically run the electric heater to quickly bring the room up to temperature when initially energized, then return to heat pump mode. This ensures that the room is brought up to temperature quickly without the usual delay associated with heat pump units.
SEPARATE HEAT/COOL FAN CYCLE CONTROL	The owner may choose between fan cycling or fan continuous mode based on property preference. Fan continuous mode is used to keep constant air flow circulation in the room during all times the unit is 'ON'. Fan cycle will conserve energy by only operating the fan while the compressor or electric heater is operating. The ability to set the fan cycling condition independently between heating and cooling mode will increase user comfort by allowing the choice of only constantly circulating air in the summer or winter time (unlike other PTAC brands that only allow one selection).
EMERGENCY HEAT OVERRIDE	In the event of a compressor failure in heat pump mode, the compressor may be locked out to provide heat through the resistance heater. This feature ensures that even in the unlikely event of a compressor failure, the room temperature can be maintained until the compressor can be serviced.
CENTRAL DESK CONTROL READY	All Friedrich digital PTACs have low voltage terminals ready to connect a central desk control energy management system. Controlling the unit from a remote location like the front desk can reduce energy usage and requires no additional accessories on the PTAC unit.
INDOOR COIL FROST SENSOR	The frost sensor protects the compressor from damage in the event that airflow is reduced or low outdoor temperatures cause the indoor coil to freeze. When the indoor coil reaches 33°F, the compressor is disabled and the fan continues to operate based on demand. Once the coil temperature returns to 59°F, the compressor returns to operation.
ULTRAQUIET AIR SYSTEM	The PZ-Series units feature an indoor fan system design that reduces sound levels without lowering airflow or preventing proper air circulation.
HIGH EFFICIENCY	The Friedrich PTAC has been engineered so that all functional systems are optimized so that they work together to deliver the highest possible performance.
DUAL MOTOR	The dual-motor design means that the indoor motor can run at slower speeds which reduces sound levels indoors.
ROTARY COMPRESSOR	High efficiency rotary compressors are used on all Friedrich PTACs to maximize durability and efficiency.
ALUMINUM ENDPLATES	Outdoor coil endplates made from Aluminum reduce corrosion on the outdoor coil common with other coil designs.
TOP-MOUNTED ANTIMICROBIAL AIR FILTERS	All Friedrich PTAC return air filters feature an antimicrobial element that has proven to prevent mold and bacterial growth in laboratory testing. PXFTB replacement filter kits feature the same antimicrobial agent. All filters are washable, reusable and easily accessed from the top of the unit without the removal of the front cover.
FILTERED FRESH AIR INTAKE	Friedrich PTAC units are capable of introducing up to 30 CFM of outside air into the conditioned space. The outdoor air passes through a washable mesh screen to prevent debris from entering the airstream.
R-410A REFRIGERANT	Friedrich PTAC units use environmentally-friendly refrigerant.
DIAMONBLUE TECHNOLOGY	Diamonblue Technology protects the outdoor coil from harsh environments.
BREAK-PROOF CONTROL DOOR	Break-proof control door design maintains the integrity of the unit.
GALVANIZED ZINC WALL SLEEVE AND BASE PAN	Galvanized zinc coated steel wall sleeve and steel base pan undergo an 11-step preparation process, are powder coated with a polyester finish and cured in an oven for exceptional durability.

---

# SPECIFICATIONS

## General Specifications 7-9k Electric Heat

PZE Series with Electric Heat			
	PZE07K	PZE09K	PZE09R
<b>PERFORMANCE DATA:</b>			
Cooling Btu	7200/6800	9600/9400	9200
Cooling Watts	600/565	815/800	800
Energy Efficiency Ratio, EER	12.0	11.8/11.8	11.5
Heater Size (kW)	3.6	3.6	3.6
Moisture Removal (pints/hr.)	0.7	1.2	1.6
Sensible Heat Ratio	0.87	0.82	0.82
<b>ELECTRICAL DATA:</b>			
Voltage (1 PHASE, 60 Hz)	230/208	230/208	265
Volt Range	253-187	253-187	292-239
Current (Amps)	2.6/2.7	3.5/3.8	4.2
Power factor	0.99	0.99	0.99
Compressor LRA	13.0	20.0	18.2
Compressor RLA	2.5	3.3	3.0
Outdoor Fan Motor, HP	0.07	0.07	0.1
<b>AIRFLOW DATA:</b>			
Indoor CFM, HIGH	335	400	400
Indoor CFM, LOW	250	250	290
Vent CFM	75	75	75
<b>PHYSICAL DATA:</b>			
Sleeve Dimensions (H x W x D)	16" x 42" x 13 3/4" (all models)		
Dimensions with Front (H x W x D)	16" x 42" x 21 1/2" (all models)		
Cut Out Dimensions (H x W x D)	16 1/4" x 42 1/4" (all models)		
Net Weight (lbs.)	104	108	113
Shipping Weight (lbs.)	126	130	136
R-410A CHARGE (oz.)	30.0	32.1	31.4

**Figure 201 (General Specs)**

# SPECIFICATIONS

## General Specifications 7-9k Heat Pump Models

PTAC Heat Pump models			
	PZH07K	PZH09R	PZH09R
<b>PERFORMANCE DATA:</b>			
Cooling Btu	7200/6800	9600/9400	9200
Cooling Watts	600/565	815/800	800
Energy Efficient Ratio, Eer	12.0/12.0	11.8/11.8	11.5
Reverse Heating Btu	6400/6300	8500/8200	8500
Heating Watts	530/520	710/685	710
Cop	3.55/3.54	3.51/3.51	3.51
Moisture Removal (Pints/Hr.)	0.7	1.2	1.6
Sensible Heat Ratio	0.87	0.82	0.82
<b>ELECTRICAL DATA:</b>			
Voltage(1 PHASE, 60 Hz)	230/208	230/208	265
Volt Range	253-187	253-187	292-239
Current (Amps)	2.6/2.7	3.5/3.8	4.2
Reverse Heat. Amps	2.3/2.5	3.0/3.3	2.7
Power Factor	0.99	0.99	0.99
Compressor LRA	13.0	20.0	18.2
Compressor RLA	2.5	3.3	3.1
Outdoor Fan Motor, HP	0.07	0.07	0.1
<b>AIRFLOW DATA:</b>			
Indoor CFM, HIGH	335	400	400
Indoor CFM, LOW	250	250	290
VENT CFM	75	75	75
<b>PHYSICAL DATA</b>			
Sleeve Dimensions (H x W x D)	16" x 42" x 13 3/4" (all models)		
Dimensions with Front (H x W x D)	16" x 42" x 21 1/2" (all models)		
Cut Out Dimensions (H x W x D)	16 1/4" x 42 1/4" (all models)		
Net Weight (lbs.)	105	109	113
Shipping Weight (lbs.)	127	131	136
R-410A CHARGE (oz.)	30.0	32.1	31.4
Dimensions with Packaging (inches)	17 7/8" x 45" x 25 1/4" (all models)		

**Figure 202 (General Specs)**

# SPECIFICATIONS

## General Specifications 12-15k Electric Heat

PTAC Electric Heat models			
	PZH12K	PZH12R	PZH15K
<b>PERFORMANCE DATA:</b>			
Cooling Btu	12000/11800	12000	14500/14300
Cooling Watts	1050/1035	1130	1420/1400
Energy Efficiency Ratio, EER	11.4/11.4	10.6	10.2/10.2
Heater Size (kW)	3.6	3.6	5.0
Moisture Removal (pints/hr.)	2.1	3.2	3.0
Sensible Heat Ratio	0.77	0.72	0.72
<b>ELECTRICAL DATA:</b>			
Voltage (1 PHASE, 60 Hz)	230/208	265	230/208
Volt Range	253-187	292-239	253-187
Current (Amps)	4.5/5.0	5.92	6.2/6.7
Power factor	0.96	0.99	0.99
Compressor LRA	28.5	25.9	34.5
Compressor RLA	5.3	4.3	6.4
Outdoor Fan Motor, HP	0.07	0.1	0.09
<b>AIRFLOW DATA:</b>			
Indoor CFM, HIGH	470	470	470
Indoor CFM, LOW	360	360	360
Vent CFM	75	75	75
<b>PHYSICAL DATA:</b>			
Sleeve Dimensions (H x W x D)	16" x 42" x 13 3/4" (all models)		
Dimensions with Front (H x W x D)	16" x 42" x 21 1/2" (all models)		
Cut Out Dimensions (H x W x D)	16 1/4" x 42 1/4" (all models)		
Net Weight (lbs.)	113	115	115
Shipping Weight (lbs.)	135	137	137
R-410A CHARGE (oz.)	30.7	30.0	34.2

**Figure 203 (General Specs)**

# SPECIFICATIONS

## General Specifications 12-15k Heat Pump

PTAC Heat Pump models			
	PZH12K	PZH12R	PZH15K
<b>PERFORMANCE DATA:</b>			
Cooling Btu	12000/11800	12000	14500/14300
Cooling Watts	1050/1035	1130	1420/1400
Energy Efficient Ratio, Eer	11.4/11.4	10.6	10.2/10.2
Reverse Heating Btu	11000/10800	11400	13600/13200
Heating Watts	930/920	1000	1180/1150
Cop	3.47/3.44	3.34	3.38/3.36
Moisture Removal (Pints/Hr.)	2.1	3.2	3.0
Sensible Heat Ratio	0.77	0.72	0.72
<b>ELECTRICAL DATA:</b>			
Voltage(1 PHASE, 60 Hz)	230/208	265	230/208
Volt Range	253-187	292-239	253-187
Current (Amps)	4.5/5.0	5.9	6.2/6.7
Reverse Heat. Amps	4.0/4.4	3.8	5.1/5.5
Power Factor	0.96	0.99	0.99
Compressor LRA	28.5	25.9	34.5
Compressor RLA	5.3	4.3	6.4
Outdoor Fan Motor, HP	0.07	0.1	0.09
<b>AIRFLOW DATA:</b>			
Indoor CFM, HIGH	470	470	470
Indoor CFM, LOW	360	360	360
VENT CFM	75	75	75
<b>PHYSICAL DATA</b>			
Sleeve Dimensions (H x W x D)	16" x 42" x 13 3/4" (all models)		
Dimensions with Front (H x W x D)	16" x 42" x 21 1/2" (all models)		
Cut Out Dimensions (H x W x D)	16 1/4" x 42 1/4" (all models)		
Net Weight (lbs.)	114	115	116
Shipping Weight (lbs.)	136	137	139
R-410A CHARGE (oz.)	30.7	30.0	34.2
Dimensions with Packaging (inches)	17 7/8" x 45" x 25 1/4" (all models)		

**Figure 204 (General Specs)**

# SPECIFICATIONS

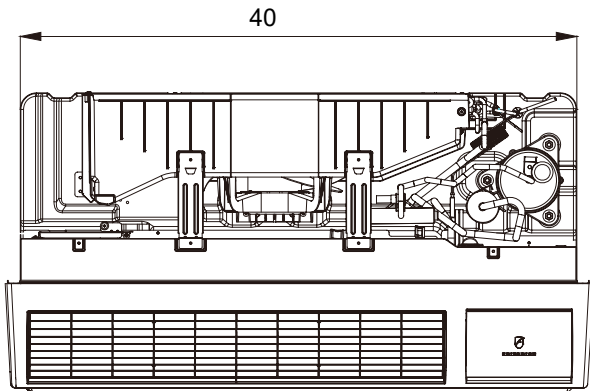
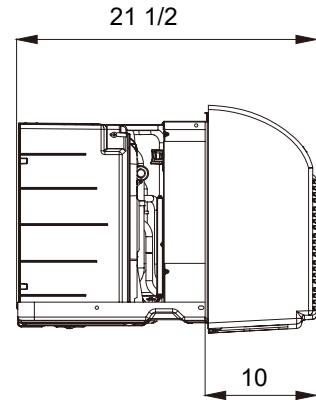
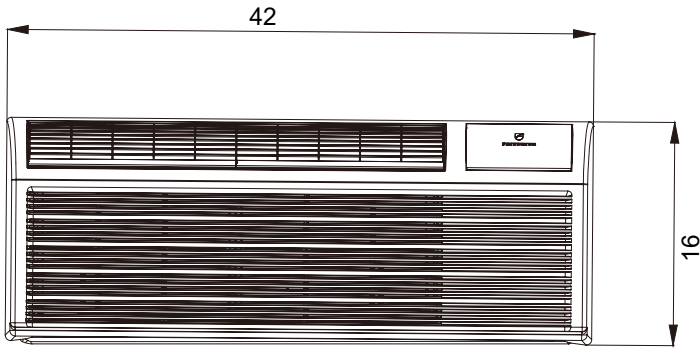

Unit:inch

Figure 205 ( Chassis Specs)

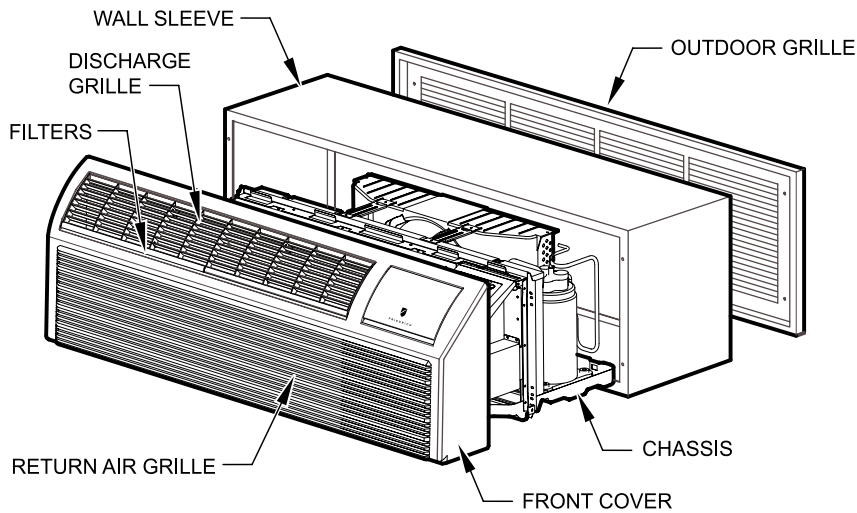

PDXWS Wall Sleeve Dimensions:  
16" H x 42" W x 13-<sup>3</sup>/<sub>4</sub>" D

Front Cover Dimensions:  
16" H x 42" W x 7-<sup>3</sup>/<sub>4</sub>" D

Cut-Out Dimensions:  
16-<sup>1</sup>/<sub>4</sub>" x 42-<sup>1</sup>/<sub>4</sub>"

Figure 206 (Typical Unit Components and Dimensions)







# SPECIFICATIONS

## Electrical Data

All 230/208 volt units are equipped with a LCDI power cords.

All 265 volt units are equipped with a non-LCDI power cord.

NOTE: Use Copper Conductors ONLY. Wire sizes are per NEC, check local codes for overseas applications.

Voltage	230V			265V		
	15	20	30	15	20	30
Heater Size	2.5 kW	3.5 kW	5.0 kW	2.5 kW	3.5 kW	5.0 kW
Receptacles						
NEMA# Receptacle	6-15R	6-20R	6-30R	7-15R	7-20R	7-30R
NEMA# Plug	6-15P	6-20P	6-30P	7-15P	7-20P	7-30P

**⚠ WARNING**



**Electrical Shock Hazard**

Turn off electrical power before service or installation.

ALL electrical connections and wiring MUST be installed by a qualified electrician and conform to the National Code and all local codes which have jurisdiction.

Failure to do so can result in property damage, personal injury and/or death.

<b>FUSE/CIRCUIT BREAKER</b>	Use ONLY type and size fuse or HACR circuit breaker indicated on unit's rating plate. Proper current protection to the unit is the responsibility of the owner. NOTE: A time delay fuse is provided with 265V units.
<b>GROUNDING</b>	Unit MUST be grounded from branch circuit through service cord to unit, or through separate ground wire provided on permanently connected units. Be sure that branch circuit or general purpose outlet is grounded. The field supplied outlet must match plug on service cord and be within reach of service cord. Refer to Table 1 for proper receptacle and fuse type. Do NOT alter the service cord or plug. Do NOT use an extension cord.
<b>RECEPTACLE</b>	The field supplied outlet must match plug on service cord and be within reach of service cord. Refer to Table 1 for proper receptacle and fuse type. Do NOT alter the service cord or plug. Do NOT use an extension cord.

## B. Power Cord Information (230/208V models only)

All Friedrich 230/208V PTAC units are shipped from the factory with a Leakage Current Detection Interrupter (LCDI) equipped power cord. The LCDI device meets the UL and NEC requirements for cord connected air conditioners effective August 2004.

To test your power supply cord:

1. Plug power supply cord into a grounded 3 prong outlet.
2. Press RESET.
3. Press TEST (listen for click; Reset button trips and pops out).
4. Press and release RESET (listen for click; Reset button latches and remains in). The power supply cord is ready for operation.

NOTE: The LCDI device is not intended to be used as a switch.

Once plugged in the unit will operate normally without the need to reset the LCDI device.

If the LCDI device fails to trip when tested or if the power supply cord is damaged it must be replaced with a new supply cord obtained from the product manufacturer, and must not be repaired.

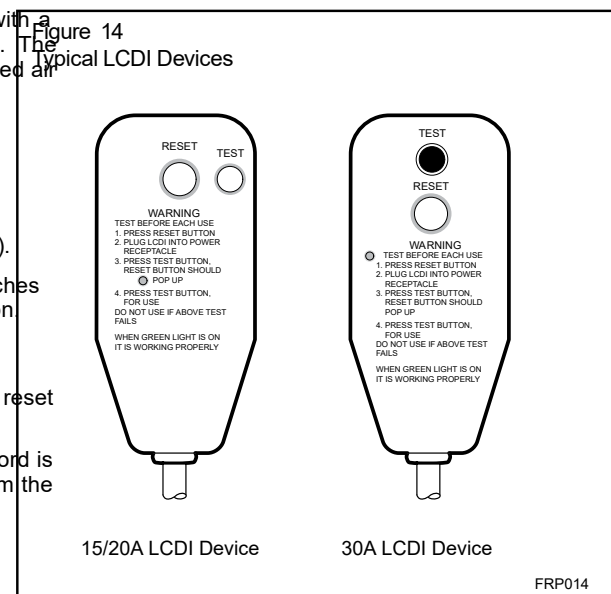

# SPECIFICATIONS

## Electrical Data

Table 2					
Model	Heater kW	Power Cord Kit	Voltage	Amperage	Receptacle
PZE/PZH07K	3.6	PXPC23020A (STD)	230/208	20	NEMA 6-20r
PZE/PDZ09K	3.6	PXPC23020A (STD)	230/208	20	NEMA 6-20r
PZE/PZH12K	3.6	PXPC23020A(STD)	230/208	20	NEMA 6-20r
PZE/PZH15K	5.0	PXPC23030 (STD)	230/208	30	NEMA 6-30r
PDE/PDH09R	3.6	PXPC23020A (STD)	265	20	NEMA 7-20r
PDE/PDH12R	3.6	PXPC26530	265	30	NEMA 7-30r

## Electrical Wiring for 265 Volt Models



### Power Cord Installation

All 265V PTAC/PTHP units come with a factory installed non-LCDI power cord for use in a subbase. If the unit is to be hard-wired refer to the instructions below.

**NOTE:** It is recommended that the PXSB subbase assembly, the PXCJA conduit kit (or equivalent) be installed on all hardwire units. If installing a flush-floor mounted unit, make sure the chassis can be removed from the sleeve for service and maintenance.

**To install the line voltage power leads and conduit to chassis, follow the instructions below and refer to Figures 25-27 on page 19. PXCJA Conduit Kit is required with this setup.**

1. Follow the removal process of the chassis's junction box (Figure 25).
2. Prepare the 265V (or 230V) power cord for connection to the chassis' power cord connector by cutting the cord to the appropriate length (refer to Figure 26 and follow Figure 15). Power cord harness selection shown on Table 2

 <b>WARNING</b>	
	<p><b>Electrical Shock Hazard</b></p> <p>Turn off electrical power before service or installation.</p> <p>ALL electrical connections and wiring <b>MUST</b> be installed by a qualified electrician and conform to the National Code and all local codes which have jurisdiction.</p> <p>Failure to do so can result in property damage, personal injury and/or death.</p>

# SPECIFICATIONS

## Electrical Data

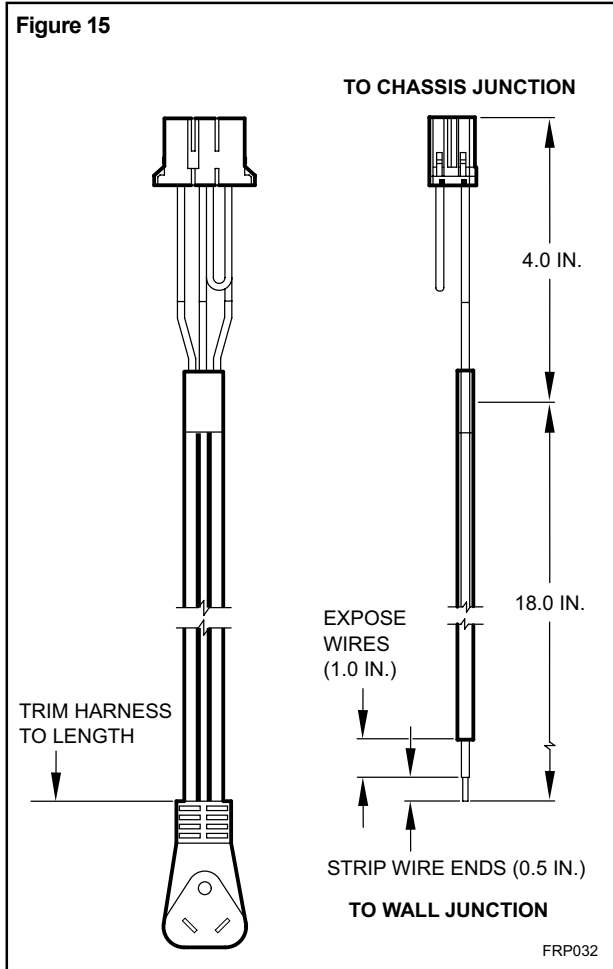

3. Route the cut ends of harness through the conduit connector assembly and flex conduit sleeve. Be sure to use the supplied conduit bushing to prevent damage to the cord by the conduit. The cord should pass through the Locknut, Spacer, Chassis Junction Box, Conduit Connector, Bushing, then the Conduit Sleeve. See Figure 17.
4. Route the cut ends of the power cord through the elbow connector at the other end of the conduit. Tighten screws on elbow connector to secure conduit sleeve.
5. Fasten and secure the elbow connector to the wall junction box cover with locknut. Place and mount the wall junction box with the four wall mounting screws making sure to pass the wall lines through the junction box. Connect and join all wall lines with the stripped ends using wire nuts. Tighten both screws of the wall junction box cover to junction box.
6. Follow steps 4-6 and refer to Figure 27.

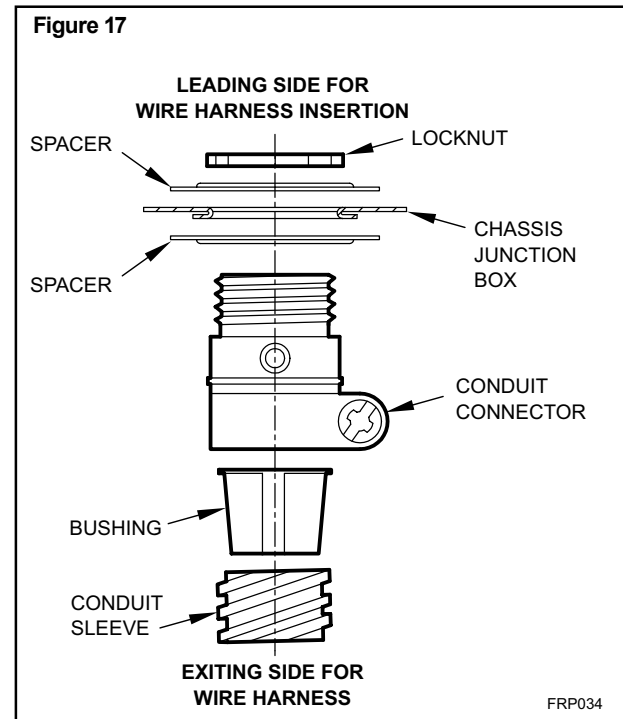
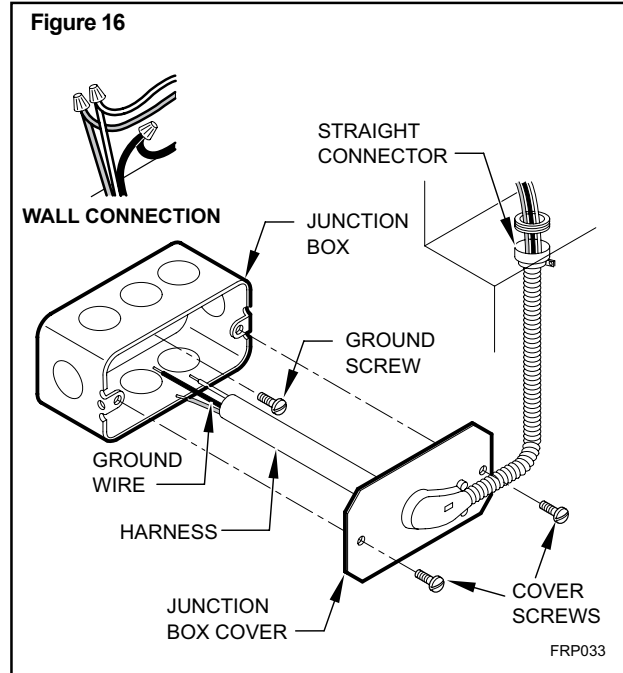

---

# OPERATION

## Function and Control Buttons and Display

### 1) Buttons

There are ON/OFF, UP, DOWN, HEAT, COOL, CONSTANT FAN and fan speed of HIGH, LOW, AUTO buttons.

1. ON/OFF: Press to turn power on or off to the unit.
2. COOL, HEAT: choose the mode of operation
3. HIGH, LOW, AUTO: choose the fan speed.
4. UP, DOWN: Adjust the setting temperature , default: 60-90°F(16~32°F).

### 2) Dual 8 Digital Tube Displayer and LED

Two 8 digital tube and 7 LEDs (ON/OFF, HIGH, LOW, AUTO, HEAT, COOL, CONSTANT FAN)

1. Mode LED display: when the unit is running in a certain mode, the corresponding LED is lit up.
2. ON/OFF LED: at ON status, the LED is lit up.
3. CONSTANT FAN LED: when this function is enabled, the LED is lit up.
4. Fan speed LED: when the unit is running at HIGH, LOW or AUTO fan speed, the corresponding LED is lit up.
5. Dual 8 digital tube displayer: normally, it displays the indoor ambient temperature. When the UP/DOWN button is pressed it displays the setting temperature. If an error occurs, it displays the ERROR CODE (See table below).

The LED close to the button indicates the current status (lit up means effective).

ERROR CODE TABLE:	
"E2"	Indoor ambient temp sensor is open circuit or short circuit
"E3"	Indoor pipe temp sensor is open circuit or short circuit
"E4"	1.Indoor vent outlet temp sensor is open circuit or short circuit 2.Outlet air overheat in Electric heating mode
"E5"	Outdoor pipe temp sensor is open circuit or short circuit
"E8"	1.Frost protection in cooling 2.Indoor pipe overheat protection in heat pump"
"E9"	High pressure protection

## Temperature Parameter

Indoor setting temperature (Ts)  
Indoor ambient temperature (T1)

## System Basic Function

Once the compressor starts, the compressor won't stop with the change of the indoor temperature. Once the compressor stops, it can only start after a 3 mins delay. (The compressor can stop immediately at the time of mode switchover, turning off the unit, adjusting setting temperature and turning off from a function error.)

### 1) Cooling Mode

Working conditions and process for cooling:

When  $T1 \geq T_s + 2^\circ\text{F}(1^\circ\text{C})$ , the unit is running in cooling mode. Meanwhile, the compressor is running and the fan is running at the setting fan speed;

When  $T1 \leq T_s - 2^\circ\text{F}(1^\circ\text{C})$ , the compressor is OFF. Meanwhile, the fan will run at the setting fan speed for 15s (CONSTANT FAN OFF); or run at the setting speed continuously (CONSTANT FAN ON);

When  $T_s - 2^\circ\text{F}(1^\circ\text{C}) < T1 < T_s + 2^\circ\text{F}(1^\circ\text{C})$ , the unit keeps previous running status.

# OPERATION

## Function and Control

### 2) Heating Mode

Working condition and process for heating:

When  $T1 \leq T_s - 2^\circ\text{F}(1^\circ\text{C})$ , the unit is running in heating mode. Heat pump or electric heating will start depending on the ambient temperature condition or the heating priority setting (#4 DIP SWITCH, ON- for heat pump and OFF-for electric heating).

When  $T1 \geq T_s + 2^\circ\text{F}(1^\circ\text{C})$ , the heating is turned OFF. Meanwhile, the fan will run at the setting fan speed for 15s or 1 minute delay (CONSTANT FAN OFF) or run at the setting speed continuously (CONSTANT FAN ON).

When  $T_s - 2^\circ\text{F}(1^\circ\text{C}) < T1 < T_s + 2^\circ\text{F}(1^\circ\text{C})$ , the unit keeps at the previous running status.

Electric heater does not work with heat pump at the same time. When  $T1 < 41^\circ\text{F}(5^\circ\text{C})$  unit will run the Electric heater, when  $T1 \geq 41^\circ\text{F}(5^\circ\text{C})$  the unit will run heat pump.

### 3) Room Freeze Protection (AUTO HEATING)

This is valid only in standby mode. The dual 8 digital tube displays "LO".

Entry condition: If #5 DIP SWITCH is set to ON to enable the indoor freeze protection and the main board detects the indoor ambient temperature lower than  $50^\circ\text{F}(10^\circ\text{C})$  for 3 minutes successively .

Quitting condition: When indoor ambient temperature rises to  $55^\circ\text{F}(13^\circ\text{C})$ , heating will stop.

### 4) Temperature Sensor Open Circuit or Short Circuit Protection

If the temperature sensor is an open circuit or a short circuit, the ERROR CODE will display on the digital tube. If the malfunction of temperature sensor is detected for 30s, the unit will turn off.

### 1) 8 DIP Switch Function

(after reprogramming, disconnect the power cord and then power up again to make it effective)

**Warning: #2 and #3 should be matched the unit type, but #2 can be switched to OFF to set as Emergency Heat**

Override!

**This will cause the E-heater to run all the time.**

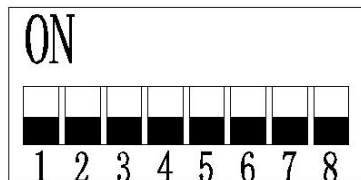

SW1

1 Reserved

2 Heat pump

ON- valid; OFF-invalid

3 E-heater

ON- valid; OFF-invalid

4 Heating priority

ON-heat pump to be prior; OFF-Electric heat to be prior

5 Room freeze protection

ON- valid; OFF- invalid

6 Auto-restart

ON- valid; OFF- invalid

7 Medium fan speed for indoor fan

ON-when HIGH fan speed, is selected the output will be medium speed instead; OFF- output is the same speed as selected.

8 Reserved

# OPERATION

## Function and Control

### Special Function

#### 1) Advanced Settings

Fahrenheit / Centigrade display

Fahrenheit and Centigrade display mode can be switched over by holding the UP and DOWN two buttons at the same time for 3s.

Setting Temperature Range

Hold UP and HIGH fan speed buttons at the same time for 5s, digital tube displayer will show R1—R8, default is R8. The temperature range as the table below:

NO.	SET POINT (MIN)°F	SET POINT (MAX)°F
R1	63	86
R2	65	86
R3	72	90
R4	72	74
R5	67	92
R6	69	90
R7	68	72
R8	60	90

Switch Over Between 24V Remote Thermostat and Control Panel

On standby mode (unit is powered on but stays in OFF), hold the “COOL” and “UP” buttons at the same time for 5 seconds, the digital tube will display “r” and buzzer beeps twice when it switches to 24V remote thermostat; it will display “p” and buzzer beeps once when it switches to control panel.

Memory Function

The unit will keep the same status it was running before power down.

FD Control (front-desk control)

The unit can be turned ON/OFF by front desk control switch. The control terminal is located on the remote thermostat interface.

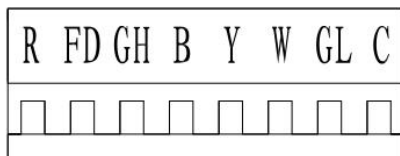

Control logic:

- Turn ON unit: short R and FD then release one time within 5s.
- Turn OFF unit: short R and FD then release twice within 5s.
- Force unit shut down for one time: short R and FD short over 5s.

NOTE: After forced shut down, you can turn on the unit again by control panel

### Protections

#### 1) Indoor Pipe Frost Protection In Cooling Mode

When compressor has run for 12 minutes, and indoor pipe temperature  $\leq 33^{\circ}\text{F}(1^{\circ}\text{C})$ , compressor and outdoor fan stop, and the indoor fan keeps running. When indoor pipe temperature  $\geq 59^{\circ}\text{F}(15^{\circ}\text{C})$  for 5 minutes, it will quit protection mode.

#### 2) High Pressure Protection

When system pressure is higher than normal condition, the outdoor pipe will over heat. When outdoor pipe temp reaches  $149^{\circ}\text{F}(65^{\circ}\text{C})$ , the compressor and outdoor fan are shut down to protect. After 3 minutes, if system comes back to normal pressure condition, unit resumes normal operation.

#### 3) Outlet Air Overheat Protection In Electric Heating Mode

Any obstacle in the vent loop, or indoor fan failure will cause outlet air overheat in electric heating mode. To prevent any danger, when outlet air temp reaches  $154^{\circ}\text{F}(68^{\circ}\text{C})$ , the E-heater will shut down. If the temperature has reduced after one minute, it will restart.

# OPERATION

## Digital Control User Input Configuration

The adjustable control dip switches are located at the front portion of the digital Smart Center. The inputs are only visible and accessible with the front cover removed from the PTAC.

### Dip Switch Setting

1. Switch 1-Reserved.
2. Switch 2-Heat pump enable/disable.  
Moving Dip Switch #2 to "OFF" can be set as Emergency Heat Override. In the unlikely event of a compressor failure, a heat pump unit may be switched to operate in only the electric heat mode until repairs can be made.
3. Switch 3-Electric strip enable/disable.
4. Switch 4-Heating priority  
ON-heat pump to be prior; OFF-Electric heat to be prior
5. Switch 5-Room Freeze Protection  
Units are shipped from the factory with the room freeze protection enable. Room Freeze Protection can be switched off at the owner's preference by moving Dip Switch 5 to "OFF". This feature will monitor the indoor room conditions and in the event that the room falls below 40°F, the unit will automatically run "heating". This occurs regardless of mode.
6. Switch 6-Electric memory enable/disable  
The factory setting is enabled. The smart center will remember user's setting. After power out recovery, the unit will operate the same status as before power cut. Moving Dip Switch 6 to "OFF" will disable this feature, smart center will no more remember settings.
7. Switch 7- Medium fan speed for indoor fan ON-when press the HIGH fan speed, output the medium speed instead; OFF-output the same speed as selected.
8. Switch 8-Reserved.

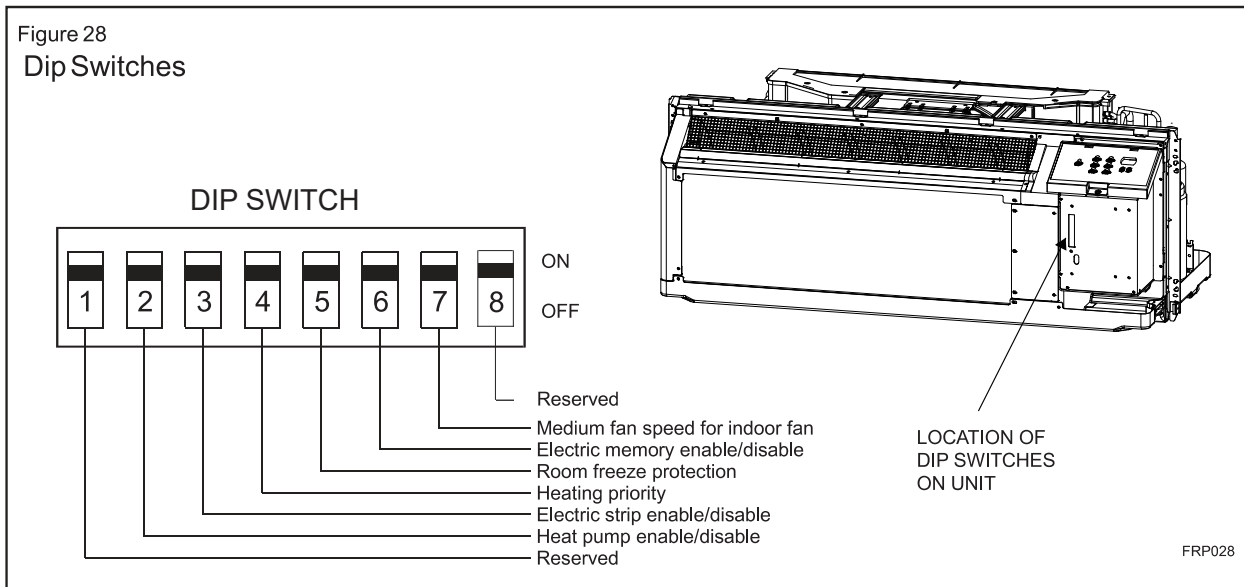

Switch	Description	Function	Factory Setting	Option
#1	Reserved	/	OFF	/
#2	Heat pump	ON-enable heat pump; OFF-disable heat pump, run electric heat only.	HP models-ON Electric heat only-OFF	OFF-Overrides compressor operation(HP models only)
#3	Electric strip	ON-enable electric heat; OFF-disable electric heat.	ON	Forbidden moving to OFF
#4	Reserved	Heating priority	OFF-Electric heating prior	ON-Heat pump prior
#5	Room Freeze Protection	ON-Allows the unit to ensure the indoor room temperature does not fall below 40°F even when turned off. OFF-disable freeze protection.	ON	OFF
#6	Electric memory enable/disable	ON-enable; OFF-disable.	ON	OFF
#7	Medium fan speed for indoor fan	ON-When press the HIGH fan speed, output the medium speed instead; OFF-output the same speed as selected.	7K-ON 9K/12K/15K-OFF	Forbidden changing factory setting
#8	Reserved	/	OFF	/

# OPERATION

## Digital Control

### Digital Control Panel



FRP029

### °F vs °C Display

The unit is factory configured to display all temperatures in degrees Fahrenheit (°F). To switch to degrees Celsius, press the "UP" and "DOWN" buttons simultaneously for three seconds. The display will switch to C degrees. To revert back to °F, press the "UP" and "DOWN" buttons simultaneously for three seconds. The display will switch to F degrees.

### Cooling Mode

Pressing the "Cool" button after turn the unit on will put the unit into cooling mode. Press "UP" or "DOWN" button to adjust the set point, the unit will cycle the compressor on and off to maintain a comfortable room. The compressor will cycle on anytime that the room temperature is 2 °F above the set point. The fan will either be continuous or cycling, depends on the "Constant Fan" selection. See Constant Fan section.

### Heating Mode

After turning on the unit, pressing the "Heat" button will put the unit into heating mode.

### Heat Pump Models (PZH)

When the "Heat" button is pressed initially the unit may call for heat pump or electric strips (depends on different ambient temperature or DIP Switch 4 settings) to bring the room to the set point. When the room temperature falls 2 °F below the set point, the unit will cycle the compressor or electric strip on. The fan will either be continuous or cycling, depends on the "Constant Fan" selection. See Constant Fan section. When the outdoor coil temperature falls below 26 °F for 3 minutes, the unit will operate the electric strip instead of heat pump. Only when the room temperature reaches the set point and the outdoor coil temperature rises to 41 °F, the compressor will be allowed to operate again.

### Heat/Cool Models (PZE)

After pressing the "Heat" button, adjust the set point and the unit will cycle the electric strip on and off to maintain a comfortable room. The heater will come on anytime that the room temperature is 2 °F below the set point. The fan will either continuous or cycling, depends on the "Constant Fan" selection. See Constant Fan section.

### Emergency Heat Operation

In the event of a compressor failure in heat pump mode, the compressor may be locked out to provide heat through the electric strip heater. This feature ensures that even in the unlikely event of a compressor failure, the room temperature can be maintained until the compressor can be serviced. Dip switch 2 controls the emergency heat setting.

### Constant Fan

Pressing the "Constant Fan" button will provide constant or cycle fan operation in cooling or heating modes. The fan speed selection is made by pressing either "High" or "Low" or "Auto" fan speed button.

### Setting Temperature Limit

Hold "UP" and "High" fan speed buttons at the same time for 5s, digital tube displayer will show R1-R8, default is R8. The temperature(°F) range as below:

- R1: 63-86
- R2: 65-86
- R3: 72-90
- R4: 72-74
- R5: 67-92
- R6: 69-90
- R7: 68-72
- R8: 60-90

# OPERATION

## Refrigeration Sequence Of Operation

A good understanding of the basic operation of the refrigeration system is essential for the service technician. Without this understanding, accurate troubleshooting of refrigeration system problems will be more difficult and time consuming, if not (in some cases) entirely impossible. The refrigeration system uses four basic principles in its operation which are as follows:

1. "Heat always flows from a warmer body to a cooler body."
2. "Heat must be added to or removed from a substance before a change in state can occur"
3. "Flow is always from a higher pressure area to a lower pressure area."
4. "The temperature at which a liquid or gas changes state is dependent upon the pressure."

The refrigeration cycle begins at the compressor when a demand is received from the thermostat. Starting the compressor creates a low pressure in the suction line which draws refrigerant gas (vapor) into the compressor. The compressor then "compresses" this refrigerant vapor, raising its pressure and its (heat intensity) temperature.

The refrigerant leaves the compressor through the discharge line as a hot high pressure gas (vapor). The refrigerant enters the condenser coil where it gives up some of its heat. The condenser fan moving air across the coil's finned surface facilitates the transfer of heat from the refrigerant to the relatively cooler outdoor air.

When a sufficient quantity of heat has been removed from the refrigerant gas (vapor), the refrigerant will "condense" (i.e. change to a liquid). Once the refrigerant has been condensed (changed) to a liquid it is cooled even further by the air that continues to flow across the condenser coil.

The design determines at exactly what point (in the condenser) the change of state (i.e. gas to a liquid) takes place. In all cases, however, the refrigerant must be totally condensed (changed) to a liquid before leaving the condenser coil.

The refrigerant leaves the condenser coil through the liquid line as a warm high pressure liquid. It next will pass through the refrigerant drier (if equipped). It is the function of the drier to trap any moisture present in the system, contaminants, and large particulate matter.

The liquid refrigerant next enters the metering device. The metering device is called a capillary tube. The purpose of the metering device is to "meter" (i.e. control or measure) the quantity of refrigerant entering the evaporator coil. In the case of the capillary tube this is accomplished (by design) through size (and length) of device, and the pressure difference present across the device. Since the evaporator coil is under a lower pressure (due to the suction created by the compressor) than the liquid line, the liquid refrigerant leaves the metering device entering the evaporator coil. As it enters the evaporator coil, the larger area and lower pressure allows the refrigerant to expand and lower its temperature (heat intensity). This expansion is often referred to as "boiling" or atomizing. Since the unit's blower is moving indoor air across the finned surface of the evaporator coil, the expanding refrigerant absorbs some of that heat. This results in a lowering of the indoor air temperature, or cooling.

The expansion and absorbing of heat cause the liquid refrigerant to evaporate (i.e. change to a gas). Once the refrigerant has been evaporated (changed to a gas), it is heated even further by the air that continues to flow across the evaporator coil.

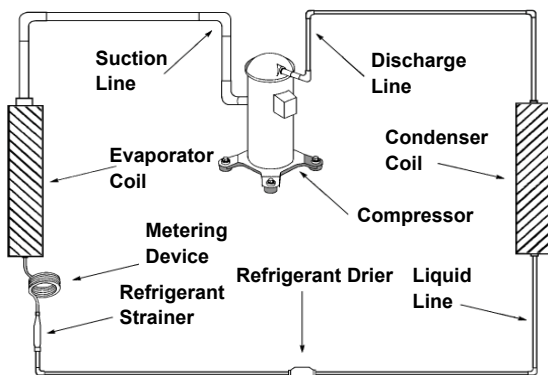

Figure 301 (Sequence of Operation)

The particular system design determines at exactly what point (in the evaporator) the change of state (i.e. liquid to a gas) takes place. In all cases, however, the refrigerant must be totally evaporated (changed) to a gas before leaving the evaporator coil.

The low pressure (suction) created by the compressor causes the refrigerant to leave the evaporator through the suction line as a cool low pressure vapor. The refrigerant then returns to the compressor, where the cycle is repeated.

# OPERATION

## Refrigerant System Diagram

### (1) Cooling + Heat Pump + Auxiliary Electric Heater

PZH07K3SB PZH09K3SB PZH09R3SB PZH12K3SB PZH12R3SB PZH15K5SB

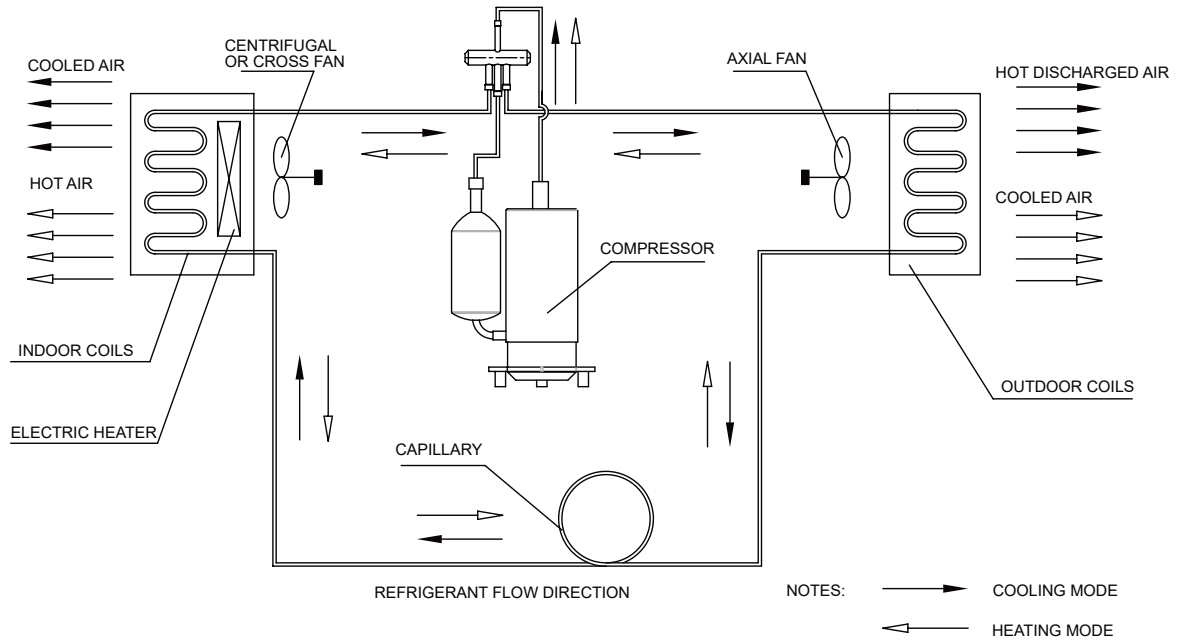

### (2) Cooling + Electric Heater

PZE07K3SB PZE09K3SB PZE09R3SB PZE12K3SB PZE12R3SB PZE15K5SB

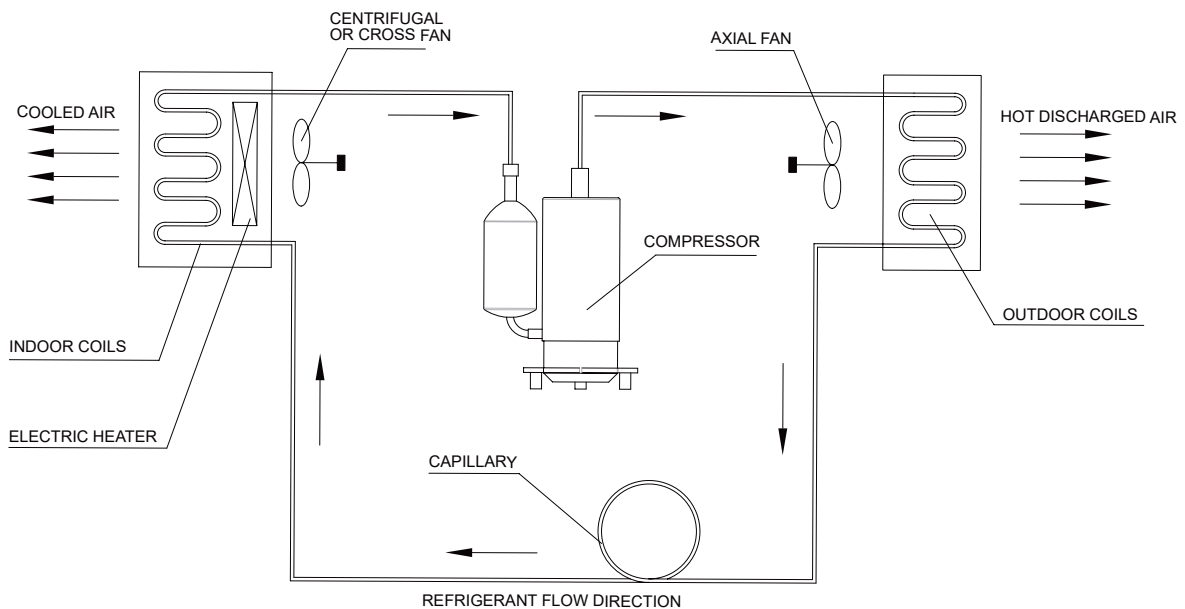

Figure 301 (Sequence of Operation)

---

# Routine Maintenance

## Coils & Chassis

**NOTE:** Do not use a caustic cleaning agent on coils or base pan. Use a biodegradable cleaning agent and degreaser. The use of harsh cleaning materials may lead to deterioration of the aluminum fins or the coil end plates.

The indoor coil and outdoor coils and base pan should be inspected periodically (annually or semi-annually) and cleaned of all debris (lint, dirt, leaves, paper, etc.) as necessary. Under extreme conditions, more frequent cleaning may be required. Clean the coils with and base pan with a coil comb or soft brush and compressed air or vacuum. A low pressure washer device may also be used; however, you must be careful not to bend the aluminum fin pack. Use a sweeping up and down motion in the direction of the vertical aluminum fin pack when pressure cleaning coils.

**NOTE:** It is extremely important to insure that none of the electrical and/or electronic parts of the unit get wet when cleaning. Be sure to cover all electrical components to protect them from water or spray.

**NOTE:** When installed on or near sea coast environments, it recommended that all coils be cleaned at minimum biannually.

## Decorative Front

Use a damp (not wet) cloth when cleaning the control area to prevent water from entering the unit, and possibly damaging the electronic control.

The decorative front and the cabinet can be cleaned with warm water and a mild liquid detergent. Do NOT use solvents or hydrocarbon based cleaners such as acetone, naphtha, gasoline, benzene, etc.

The indoor coil can be vacuumed with a dusting attachment if it appears to be dirty. DO NOT BEND FINS. The outdoor coil can be gently sprayed with a garden hose.

The air filter should be inspected weekly and cleaned if needed by vacuuming with a dust attachment or by cleaning in the sink using warm water and a mild dishwashing detergent. Dry the filter thoroughly before reinstalling. Use caution, the coil surface can be sharp.

## Fan Motor & Compressor

The fan motor & compressor are permanently lubricated and require no additional lubrication.

## Wall Sleeve

Inspect the inside of the wall sleeve and drain system periodically (annually or semi-annually) and clean as required. Under extreme conditions, more frequent cleaning may be necessary. Clean both of these areas with an antibacterial and antifungal cleaner. Rinse both items thoroughly with water and ensure that the drain outlets are operating correctly. Check the sealant around the sleeve and reseal areas as needed.

Inspect for mold or mildew periodically. If present, ensure the sealing gasket around the unit is in good condition and not allowing outside air (or light) through the gasket.

## Blower Wheel / Housing / Condenser Fan / Shroud

Inspect the indoor blower and its housing, evaporator blade, condenser fan blade and condenser shroud periodically (yearly or bi-yearly) and clean of all debris (lint, dirt, mold, fungus, etc.). Clean the blower housing area and blower wheel with an antibacterial / antifungal cleaner. Use a biodegradable cleaning agent and degreaser on condenser fan and condenser shroud. Use warm or cold water when rinsing these items. Allow all items to dry thoroughly before reinstalling them.

## Electrical / Electronic

Periodically (at least yearly or bi-yearly) inspect all control components: electronic, electrical and mechanical, as well as the power supply. Use proper testing instruments (voltmeter, ohmmeter, ammeter, wattmeter, etc.) to perform electrical tests. Use an air conditioning or refrigeration thermometer to check room, outdoor and coil operating temperatures.

## Air Filter

To ensure proper unit operation, the air filter should be cleaned at least monthly, and more frequently if conditions warrant. The unit must be turned off before the filter is cleaned.

# INSTALLATION

## PTAC Installation Recommendations

For proper PTAC unit performance and maximum operating life refer to the minimum installation clearances below:

Figure 1

PTAC units should be installed no closer than 12" apart when two units are side by side. If three or more PTAC units are to operate next to one another allow a minimum of 36" between units. Also, a vertical clearance of 60" should be maintained between units installed. In the interior of the room the unit should be located a minimum of 1/4" from the floor and a minimum of 36" from the ceiling.

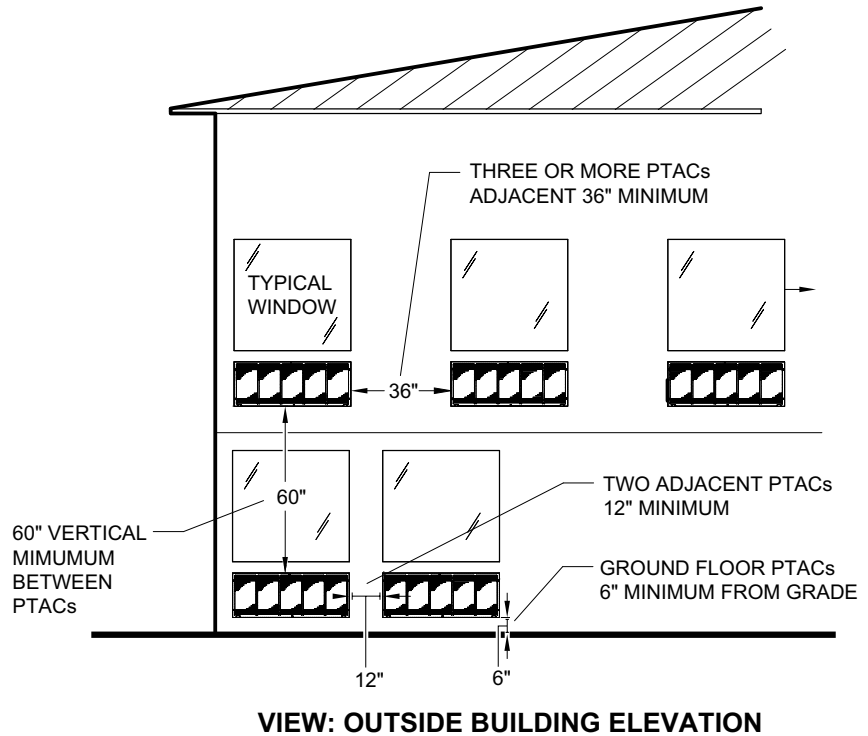

FRP001

For PTACs on the ground floor or anytime obstructions are present, use the following guidelines:

Figure 2

- For minor obstructions such as lamp poles or small shrubbery a clearance of 12" from the outdoor louver should be maintained.
- For major obstructions such as a solid fence, wall or other heat rejecting device like a condensing unit, a minimum distance of 36" should be kept.

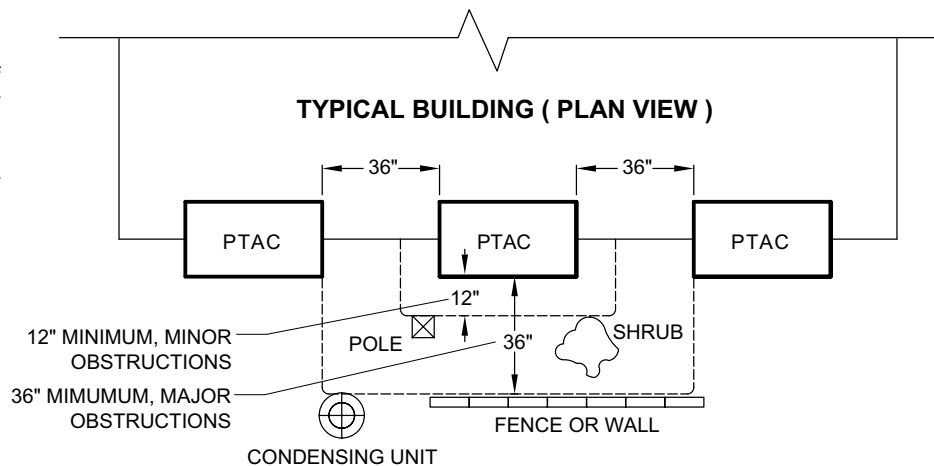

FRP002

The above suggestions are for reference only and do not represent all possible installations. Please contact Friedrich for information regarding affects of other installation arrangements. By following these simple recommendations you can be confident that your Friedrich PTAC will provide years of worry free operation.

# INSTALLATION

## Wall Sleeve Installation Instructions (PDXWS)

**NOTE:** Insure that the unit is only installed in a wall structurally adequate to support the unit including the sleeve, chassis and accessories. If the sleeve projects more than 8" into the room, a subbase or other means of support MUST be used. Please read these instructions completely before attempting installation.

<b>⚠ WARNING</b>	
	<p><b>Falling Object Hazard</b></p> <p>Not following Installation Instructions for mounting your air conditioner can result in property damage, injury, or death.</p>

<b>NOTICE</b>
<p>DO NOT allow any pitch toward the inside.</p> <p>Flashing on all 4 sides of the opening is recommended.</p> <p>Potential property damage can occur if instructions are not followed.</p>

### For Deep Wall Installation (Greater than 13 1/4") See Page 9

The following instructions apply ONLY to walls less than 13 1/4" in depth.

1. The PXDR10 Drain Kit (optional for new construction) see page 10 if applicable, must be installed before the wall sleeve is installed into the wall.
2. The External Drain (for new construction or unit replacement) see page 11, if applicable, must be installed before the wall sleeve is installed into the wall.
3. From inside the building, position the wall sleeve in the opening and push it into the wall until it protrudes at least 1/4" on the outside. Do not allow sleeve to be pulled. (See Figure 11, Page 10).
4. Position the wall sleeve with a slight tilt towards the outside to facilitate condensate drainage. It should be level side-to-side and the front should be 1/4 bubble higher than the back.

**Figure 3**

### Typical Wall Sleeve Installation

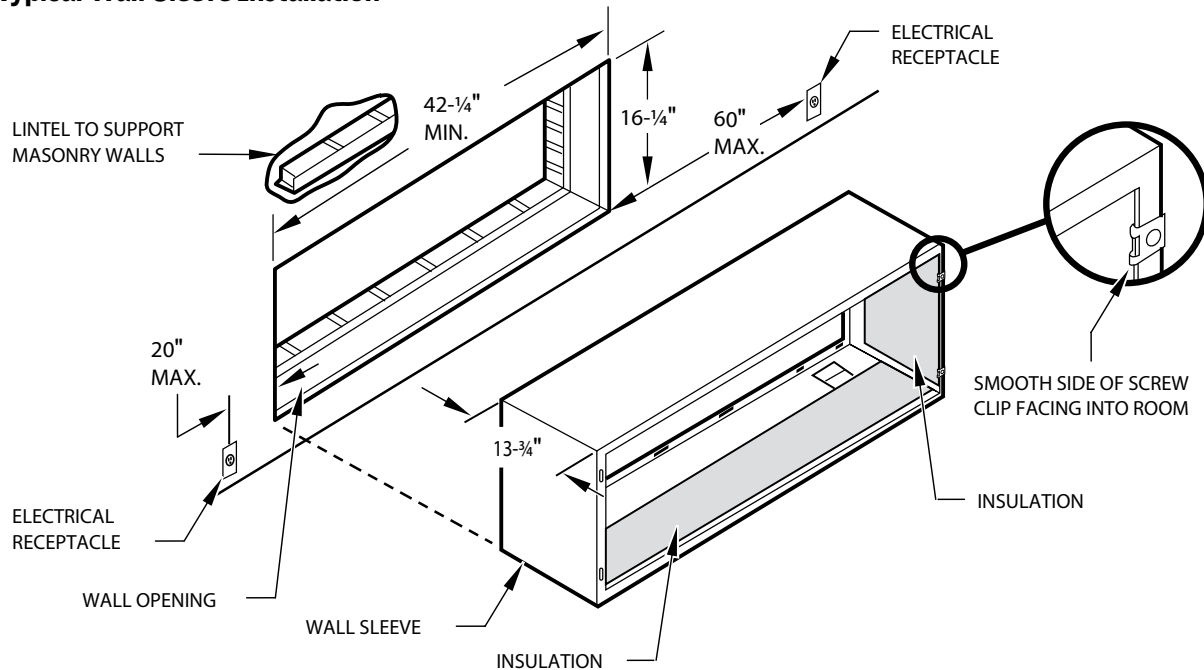

**NOTE:** All 230/208V units are manufactured with a 60" power cord and all 265V units with a 18" power cord.

FRP008

# INSTALLATION

## Alternate Wall Installations

**Figure 4**  
**Panel Wall**

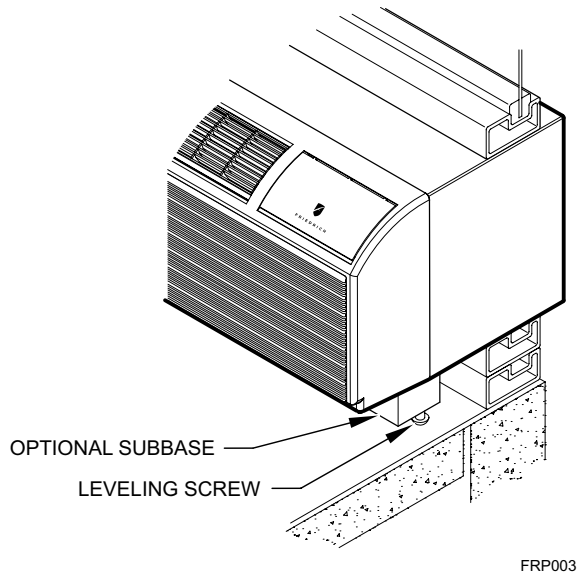

**Figure 6**  
**Curtain Wall**

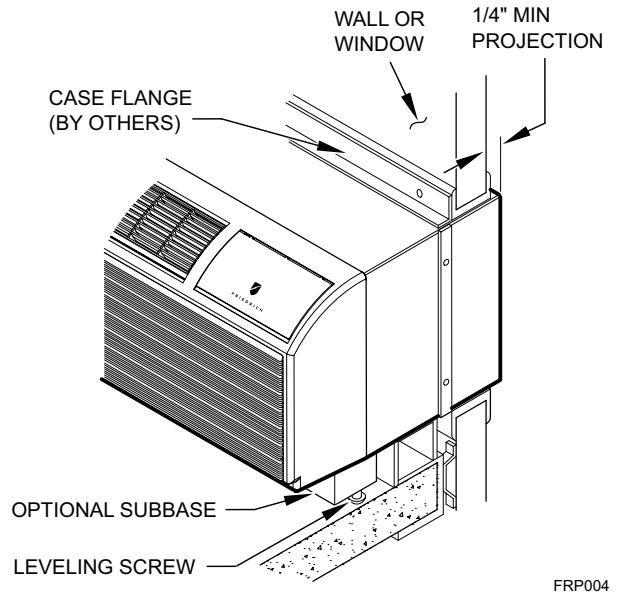

**Figure 5**  
**Frame and Brick Veneer**

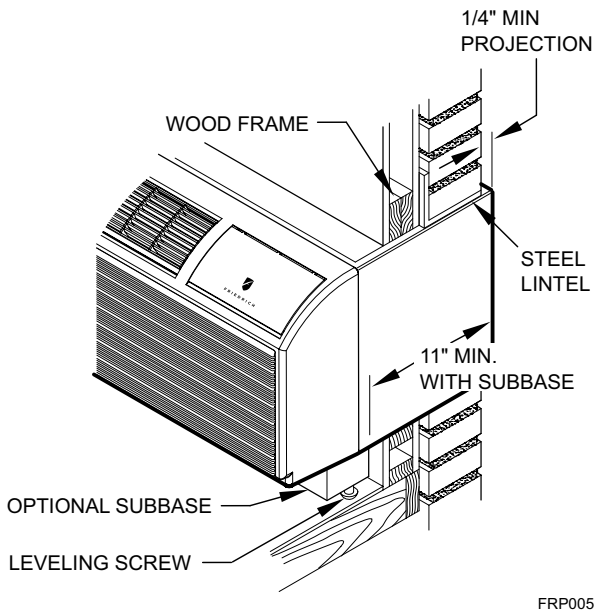

**Figure 7**  
**Block and Brick Veneer**

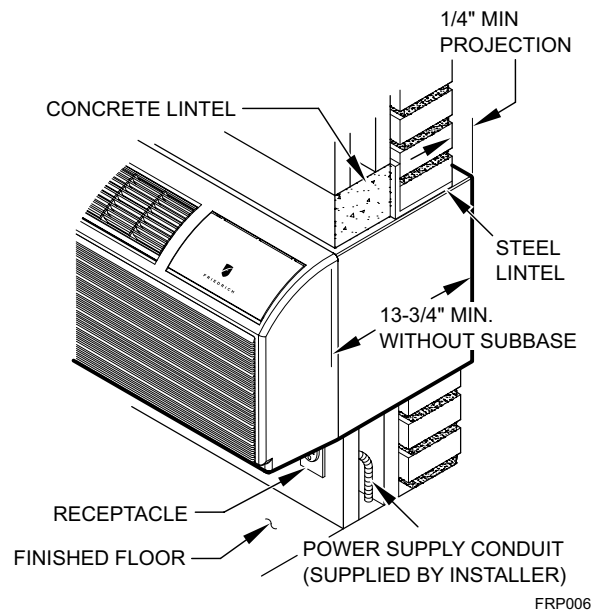

**NOTE:** Follow all wall system manufacturer installation instructions. For sunrooms and modular buildings, adhere to their installation instructions for supporting and sealing sleeve to their frames. All wall and window/wall installations must provide for proper drainage. In applications where the drain holes on the PTAC wall sleeve are not exposed beyond the wall an internal drain system is recommended. It is the installer's responsibility to ensure there is adequate drainage for the PTAC unit.

# INSTALLATION

## Alternate Wall Installations

**Figure 8**  
**Wall Sleeve Attachment**

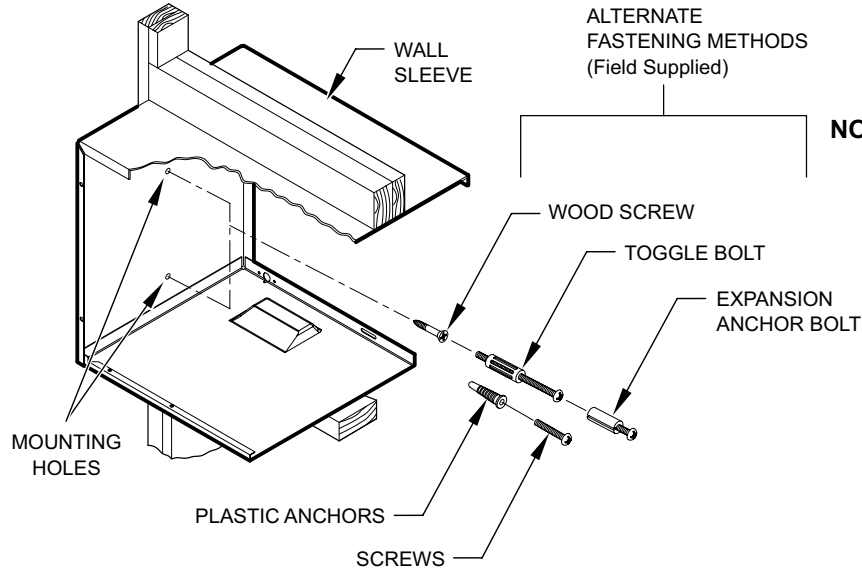

**NOTE:** The Wall Sleeve must be horizontally level (side-to-side) and pitched 1/4 bubble to the outside when installed in an opening. The mounting hole location should be approximately 2-4" from the top and bottom of the sleeve.

FRP007

**Figure 9**  
**Dimensions**

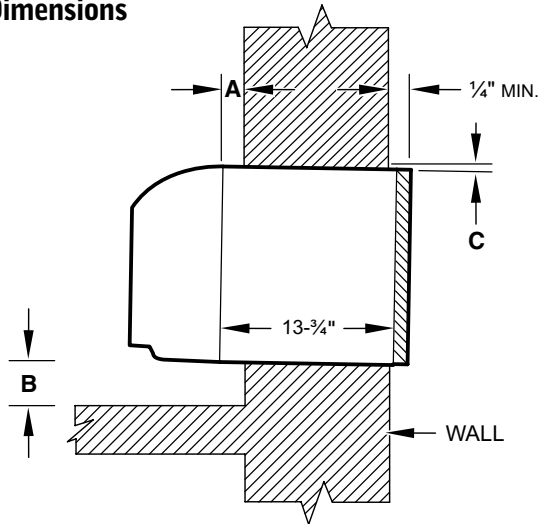

Dimension*	A	B		C
	Allow for wall finishing (Minimum)	Allow for floor finishing Min.	Max.	Allow for proper drainage (Front-to-Back)
No Accessories	1/4"	1/4"	---	---
With Subbase	1-3/4"	3-1/2"	5"	---
With Lateral Duct	3/4"	1/4"	---	---
Wall Sleeve Tilt	---	---	---	1/4"

\* If more than one accessory is to be used, use the maximum dimension. If the wall thickness is more than 13-3/4" - (A+ 1/4"), a sleeve extension must be used.

FRP009

# INSTALLATION

## Alternate Wall Installations

5. Drill two 3/16" holes through each side of the sleeve approximately 4" from top and 4" from bottom of sleeve. Screw four #10 x 1" screws (included) or appropriate fasteners for your installation, through the holes in the sides of the wall sleeve.
6. Apply sealant around the wall sleeve where it projects through the inside and outside wall surfaces. Apply the sealant to the screw heads or the tops of the fasteners used in Step #5.
7. If the chassis and exterior grille are to be installed later, leave the weatherboard and center support in place, otherwise remove and dispose of them. (See Figure 13, Page 12).
8. Provide a support lintel if the wall sleeve is installed in a concrete or masonry wall (See Figure 10, Page 9).

**Figure 10**  
**Lintel Installation**

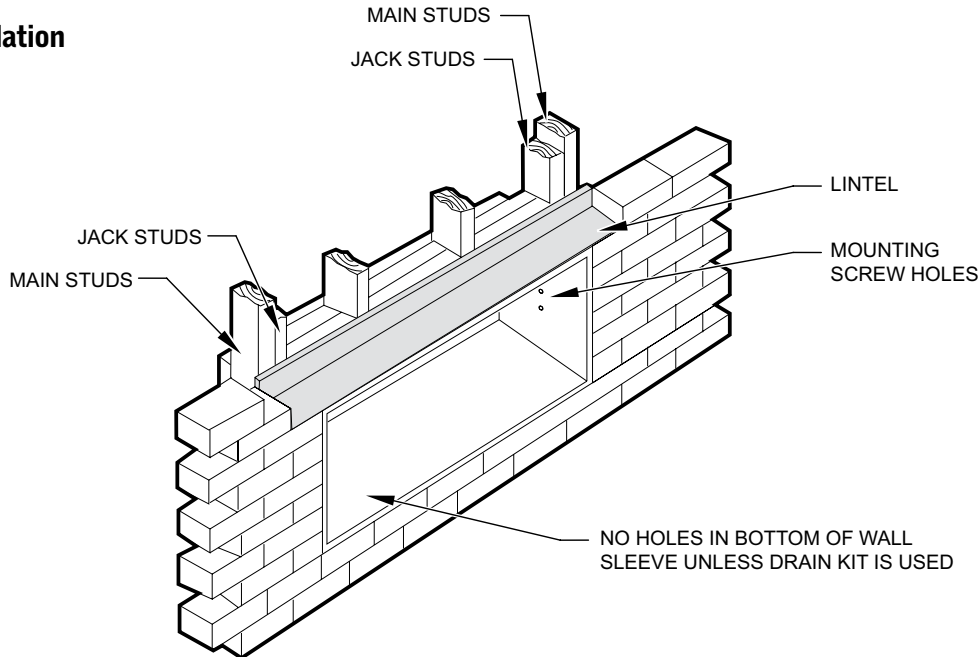

**NOTE:** Construct wall opening to comply with all applicable building codes.

FRP010

## One-Piece Deep Wall Sleeve Installation (PDXWSEXT)

If the wall is thicker than 13 1/4" a deep wall sleeve or wall sleeve extension **MUST** be used. The deep wall sleeve may be special ordered through your Sales Representative.

# INSTALLATION

## PXDR10 Drain Kit Installation

### PXDR10 Drain Kit Installation Instructions (optional for new construction)

**NOTE:** Determine whether drain will be located within the wall, on the indoor side, or will drain to the exterior of the building. Follow appropriate instructions below depending on your particular type of installation.

#### Internal Drain

**NOTE:** If installing an internal drain, you **MUST** install a drain kit on the wall sleeve before the wall sleeve is installed.

1. Refer to Figure 11 and locate the drain within the "Preferred" area of best drainage. Maintain at least a 1/2" clearance from the embossed area.
2. Using the mounting plate with the 1/2" hole as a template, mark and drill two, 3/16" mounting holes and a 1/2" drain hole in the sleeve bottom.

3. Remove the backing from the gasket and mount it on the flat side of the mounting plate. (See Figure 12, Page 11). Insert the drain tube through the hole in the gasket and mounting plate so the tube flange will be against the wall sleeve.
4. Position the assembly beneath the drilled holes and secure it with #10-24 x 1/2" machine screws and lock nuts provided. Seal the tops of the screws with silicone caulking.
5. Use 1/2" I.D. copper tube, PVC pipe, or vinyl hose (obtained locally) to connect the internal drain tube to the drain system in the building.
6. Referring to Figure 12, Detail A, Page 11, locate and assemble the (2) two cover plates and gaskets over the drain holes at the rear of the wall sleeve. Attach them with the #10 sheet metal screws provided. Make certain that the four overflow slots at the rear of the wall sleeve are not blocked (See drawing of the back of the sleeve Figure 12, Page 11).
7. If a deep wall extension (PDXWSEXT) is used, after installing the field supplied flashing, caulk as required. Be sure to caulk around the flashing and the wall sleeve where the hole was drilled for the drain tube.

**Figure 11**  
**Drain Kit Location and Installation**

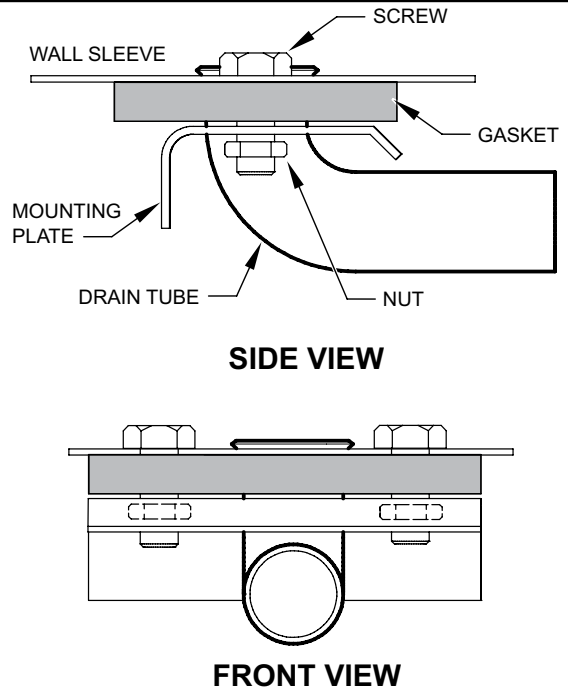
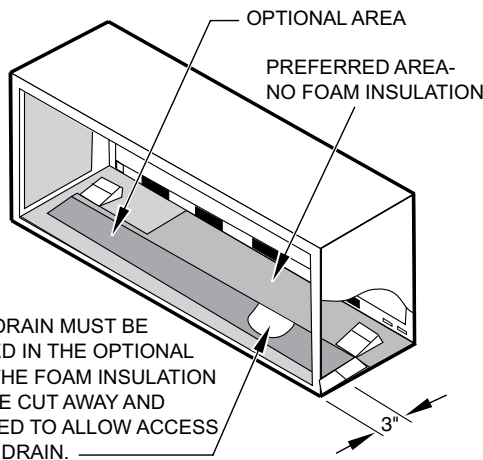

FRP011

PXDR10	
QUANTITY	DESCRIPTION
2	COVER PLATES
1	MOUNTING PLATE
1	DRAIN TUBE
3	MOUNTING PLATE GASKET
4	#10 X 1/2" SHEET METAL SCREWS
2	#10-24 X 1/2" MACH. SCREWS
2	#10-24 X 1/2" LOCKNUTS

# INSTALLATION

## External Drain

### External Drain (for new construction or unit replacement)

When using an external drain system, the condensate is removed through either of two drain holes on the back of the wall sleeve. Select the drain hole which best meets your drainage situation and install the drain kit. Seal off the other with a cover plate.

#### Drain Tube Installation (See Figure 12)

1. Peel the backing tape off the gaskets and apply the sticky side to one cover plate and one mounting plate as shown in Details A and B.
2. Place the drain tube through the gasket and the mounting plate with the flange toward the wall sleeve.
3. Attach the drain tube assembly to one of the two drain holes at the rear of the wall sleeve. The large flange on the mounting plate is positioned at the bottom of the sleeve facing toward the sleeve, Detail B. When the drain tube is positioned at the desired angle, tighten the screws.

#### Cover Plate Installation

4. Mount the foam gasket to the cover plate. Using two #10 x 1/2" sheet metal screws (provided), attach the cover plate to the remaining drain hole. Make certain the large flange on the plate is positioned at the bottom of the sleeve.
5. Discard the additional cover plate, gasket, machine screws, and locknuts.

### NOTICE

If the wall sleeve has not been installed, the drain tube must be rotated to a horizontal position until after the sleeve is installed. Tighten the mounting plate screws when the tube is in the proper position. Make certain that the four overflow slots at the rear of the wall sleeve are not blocked (See Figure 12).

When sealing the sleeve on the outside of the building, be careful NOT to let the sealant block the two condensate drain holes or the four overflow slots at the bottom flange of the sleeve.

Potential property damage can occur if instructions are not followed.

**Figure 12**  
**Drain Kit Installation**

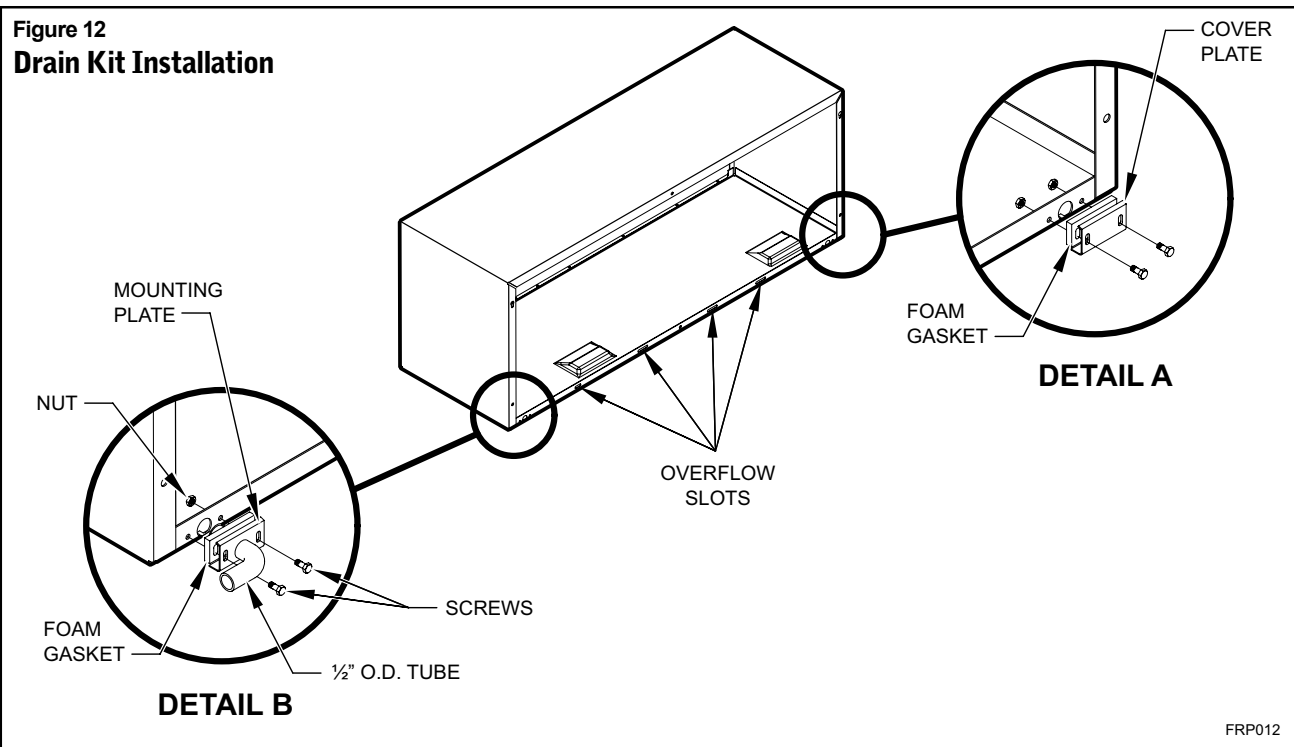

**NOTE:** The large flange on the mounting plate is positioned at the bottom of the sleeve facing toward the sleeve. The drain tube must be rotated to a horizontal position to allow for the wall sleeve to be installed into the wall. Once the wall sleeve is installed, return the drain tube to a downward angle.

# INSTALLATION

## PXGA Standard Grille

### PXGA Standard Grille

#### Installation Instructions

1. Remove the center support and weatherboard if still installed in the sleeve.
2. Insert six plastic grommets into the grille openings from the outside of the grille as shown in Figure 13.
3. Insert two #8 x 3/8" sheet metal screws (provided) in the top two outside edge plastic grommets, and tighten them half way into the grommets.
4. Grasp the grille by the attached plastic handles. Position it with the condensate drain knockouts facing down.

From inside the building, maneuver the grille through the wall sleeve and pull toward you until the screw heads are inserted into the keyhole slots at the top of the wall sleeve. Tighten the two screws completely.

5. Insert the remaining screws into the remaining holes and tighten securely.

**⚠ WARNING**



**Falling Object Hazard**

Not following Installation Instructions for mounting your air conditioner can result in property damage, injury, or death.

**Figure 13**  
**Standard Grille**

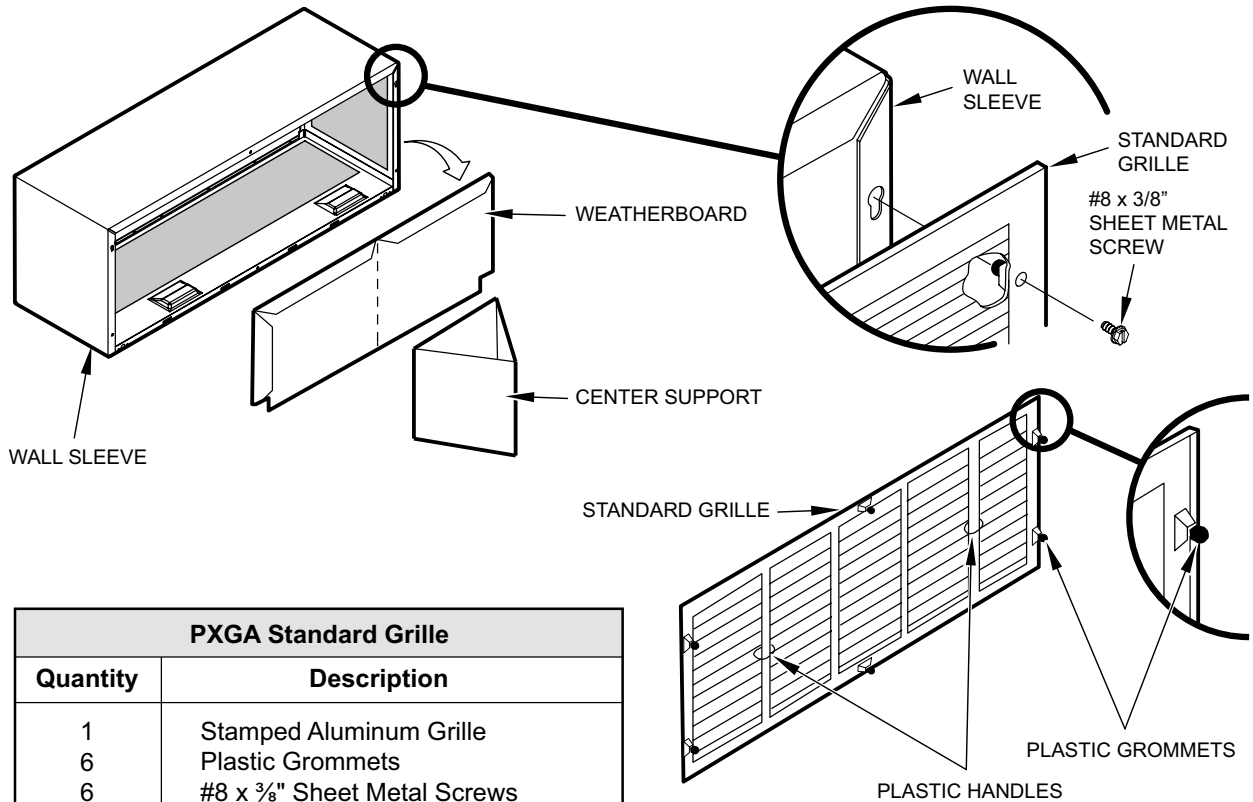

PXGA Standard Grille	
Quantity	Description
1	Stamped Aluminum Grille
6	Plastic Grommets
6	#8 x 3/8" Sheet Metal Screws

FRP013

# INSTALLATION

## Chassis Install Preparation

**Check to be sure the wall sleeve, extension (if used), grille, and drain kit are installed properly before chassis installation.**

1. Remove the weatherboard and center support from the sleeve (if still in place). Be sure an outdoor grille is attached.

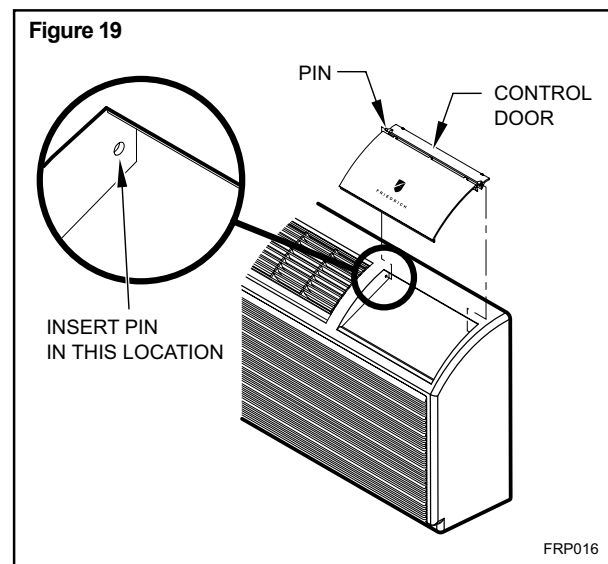
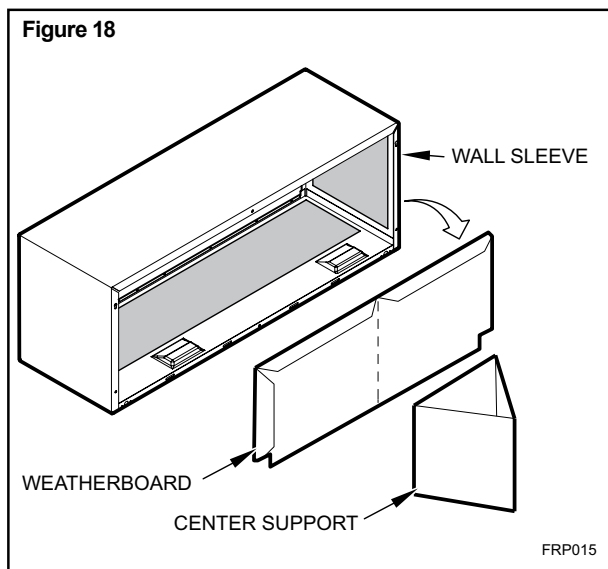

**NOTE:** To avoid breaking the door or hinge pins, do not apply excessive force when installing.



**NOTE:** Use a wall sleeve adapter kit (PXSE) if installing a P-Series chassis in a T-Series sleeve.

**IMPORTANT:** When installing a Friedrich PTAC into an existing sleeve, it is important to ensure that the unit is installed completely. Inspection of the air seal between the condenser air baffles and around the indoor mounting flange is recommended.

In some cases additional gaskets or baffling may be required.

 <b>WARNING</b>	
	<p><b>Suffocation Hazards</b></p> <p>Keep bag away from babies and children.</p> <p>Do NOT use in cribs, beds or playpens. Destroy immediately after opening. This bag is NOT a toy.</p> <p>Failure to do so can result in personal injury and/or death.</p>

2. Remove the front cover contained in a protective plastic bag from chassis. Remove the bag and dispose of it properly.

If the control door is not installed, follow these steps:

- a. From the front cover, slide the right control door pin into the hole on the right side of the front cover.
- b. Slide the left door pin into the hole on the left side of the front cover opening.
- c. Snap cover into place.

# INSTALLATION

## Chassis Install Preparation

### CAUTION

#### Unit Damage Hazard

Failure to follow this caution may result in equipment damage or improper operation.

Failure to remove shipping tape and screw will prevent fresh air vent door from opening and may result in damage to vent door cable.

- Carefully remove shipping tape from the front panel and vent door. See Figure 20

**Figure 20**  
**Shipping Tape Location**

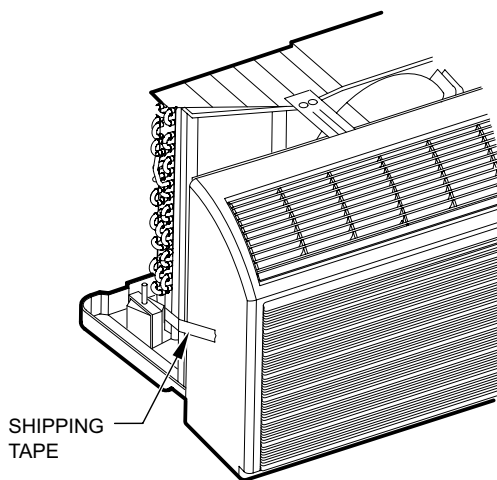

FRP020

- Remove shipping screw from the vent door, if present. See Fig 21.

**Figure 21**  
**Shipping Screw Location**

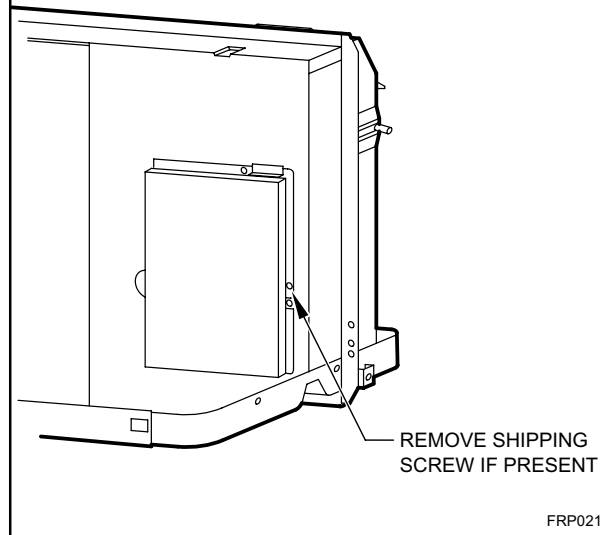

FRP021

- Remove front panel. See Figure 22.

**Figure 22**  
**Removing Front Panel**

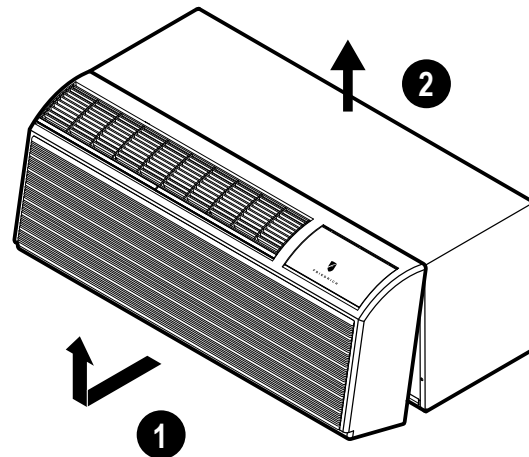

FRP022

Pull out at the bottom to release it from the tabs (1). Then lift up (2).

**NOTE:** If the unit is mounted flush to the floor, the service cord **MUST** be rerouted at the bottom of the front cover on the side closest to the receptacle. A notch **MUST** be made in the front cover side where the cord exits the unit. It is the responsibility of the installer to create an exit notch.

# INSTALLATION

## Chassis Installation

### Chassis Installation

1. Lift unit level and slide unit into wall sleeve until front seal rests firmly against front of wall sleeve.

**Figure 23**  
**Securing Unit**

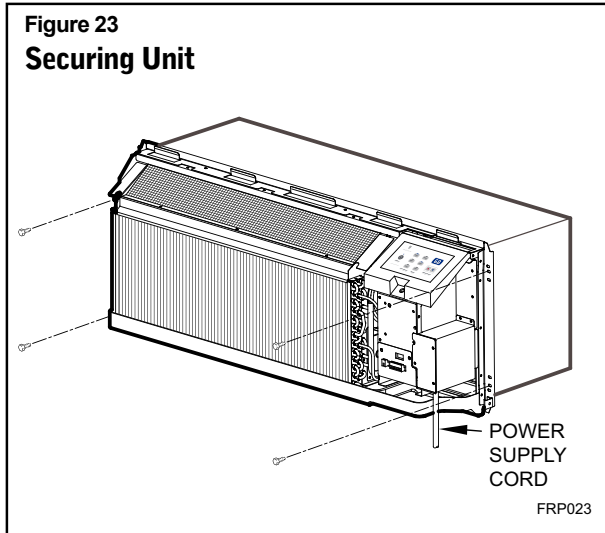

2. Locate the four supplied chassis mounting screws. Insert the screws through the chassis mounting flange holes that are aligned with the speed nuts in the wall sleeve. Tighten all four screws (two per side).

**Figure 24**  
**Replacing Front Panel**

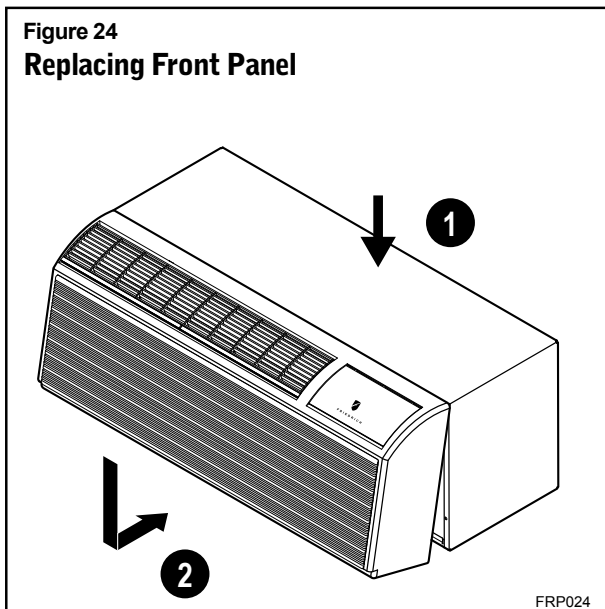

3. Place tabs over top rail (1). Push inward at bottom until panel snaps into place (2).
4. Reinstall front panel. See Figure 24.

### ⚠ CAUTION



#### **Excessive Weight Hazard**

Use two or more people when installing your air conditioner.

Failure to do so can result in back or other injury.

### **NOTICE**

Copper refrigerant tubes are NOT handles.  
Do NOT use tubing to lift or move chassis.

To remove the front cover, pull the bottom end forward and lift it up to clear the L bracket across the top of the chassis.

5. Plug the cord (if applicable) into the appropriate receptacle. Restore power to the unit.

# INSTALLATION

## How To Connect

**IMPORTANT: Please read following electrical safety data carefully.**

<b>⚠ WARNING</b>	
	<p><b>Electrical Shock and/or Unit Operation and Damage Hazard</b></p> <p>Failure to follow this warning could result in personal injury or death and/or unit damage.</p> <ul style="list-style-type: none"> <li>• Follow the National Electrical Code (NEC) or local codes and ordinances.</li> <li>• For personal safety, this unit <b>MUST BE</b> properly grounded.</li> <li>• Protective devices (fuses or circuit breakers) acceptable for unit installations are specified on the nameplate of each unit.</li> <li>• <b>Do not</b> use an extension cord with this unit.</li> <li>• Aluminum wiring in the building may present special problems - consult a qualified electrician.</li> <li>• <b>When unit is in STOP position, there is still voltage to the electrical controls.</b></li> <li>• Disconnect power to unit before servicing by:               <ol style="list-style-type: none"> <li>1. Removing power cord (if it has one) from wall receptacle.</li> <li>2. Removing branch circuit fuses or turning circuit breakers off at panel.</li> </ol> </li> </ul>

1. Remove front panel. See Figure 22.
2. Remove junction box.
  - Remove junction box cover by removing three screws from front. Remove junction box by taking out top, rear and side screws. See Figure 25.

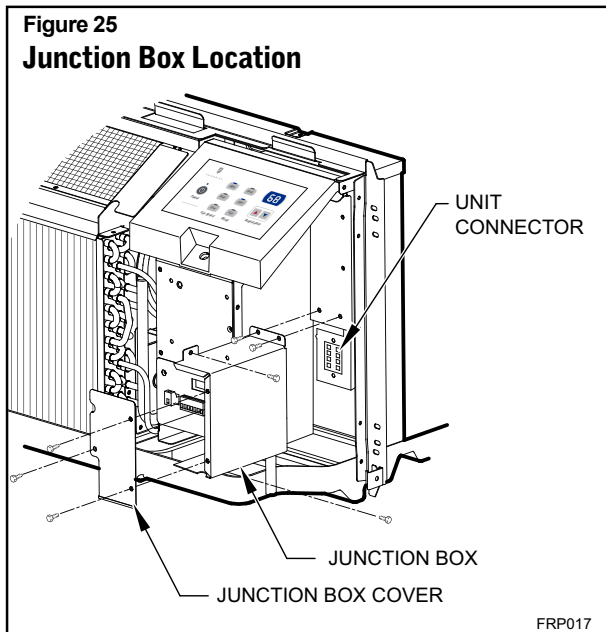

3. Connect accessory power supply cord or hard wire connector to unit connector. See Figure 26.
  - Units must be installed using the appropriate power supply kit. See Table 2 --POWER CONNECTION CHART. These connections must be followed.

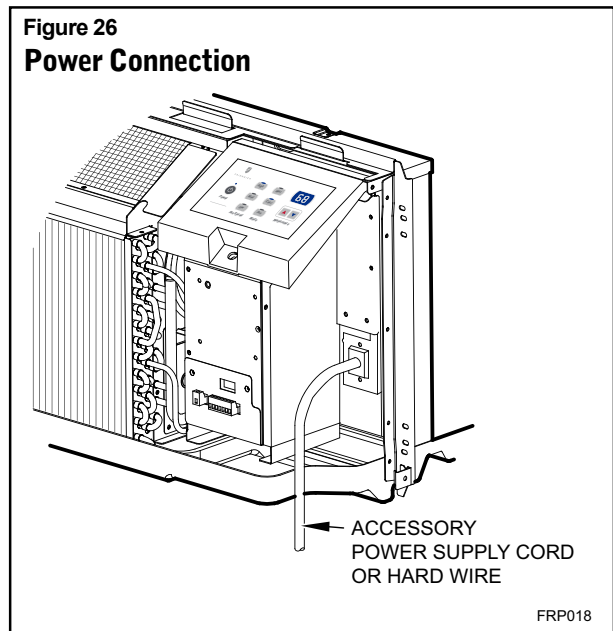

See Table 2 on page 14 for power cord accessory options and ratings.

4. Reinstall junction box and cover.
  - Use wire clamp to attach power cord to basepan. Secure with screws (included) See Figure 27.
  - Replace junction box and cover with screws removed from Step 2. Tighten securely.
5. Replace front panel. See Figure 24.
6. Connect power to unit.

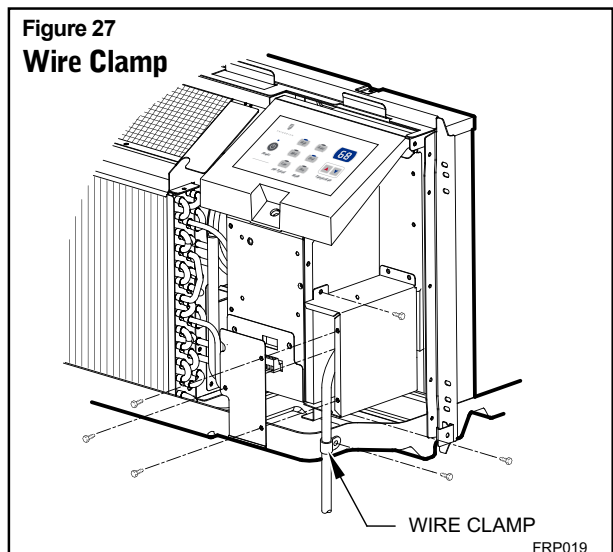

# INSTALLATION



## Final Inspection & Start-up Checklist

### Final Inspection & Start-up Checklist

- Inspect and ensure that all components and accessories have been installed properly and that they have not been damaged during the installation process.
  - Check the condensate water drain(s) to ensure they are adequate for the removal of condensate water, and that they meet the approval of the end user.
  - Ensure that all installations concerning clearances around the unit have been adhered to. Check to ensure that the unit air filter, indoor coil, and outdoor coil are free from any obstructions.
  - Ensure that the entire installation is in compliance with all applicable national and local codes and ordinances that have jurisdiction.
  - Secure components and accessories, such as the chassis, decorative front cover and control door.
  - Start the unit and check for proper operation of all components in each mode of operation. Instruct the owner or operator of this units operation, and the manufacturer's recommended routine maintenance schedule.
- NOTE: A log for recording the dates of maintenance and/or service is recommended.
- Present the owner or operator of the equipment with the Installation & Operation manual, all accessory installation instructions, and the name, address and telephone number of the Authorized Friedrich Warranty Service Company in the area for future reference if necessary.

## Routine Maintenance

To ensure proper unit operation and life expectancy the following maintenance procedures should be performed on a regular basis.

 <b>WARNING</b>	
	<p><b>Electrical Shock Hazard</b></p> <p>Unplug Unit or turn off electrical power to unit prior to performing maintenance procedures.</p> <p>Failure to do so can result in electrical shock or death.</p>

### Air Filter

To ensure proper unit operation, the air filters should be cleaned at least monthly, and more frequently if conditions warrant. The unit must be turned off before the filters are cleaned.

To remove the air filters, grasp the top of the filter and lift out of the front cabinet. Reverse the procedure to reinstall the filters.

Clean the filters with a mild detergent in warm water, and allow them to dry thoroughly before reinstalling.

### Coils & Chassis

NOTE: Do not use a caustic coil cleaning agent on coils or base pan. Use a biodegradable cleaning agent and degreaser. The use of harsh cleaning materials may lead to deterioration of the aluminum fins or the coil end plates.

The indoor coil and outdoor coils and base pan should be inspected periodically (annually or semi-annually) and cleaned of all debris (lint, dirt, leaves, paper, etc.) as necessary. Under extreme conditions, more frequent cleaning may be required. Clean the coils and base pan with a soft brush and compressed air or vacuum. A pressure washer may also be used,

however, you must be careful not to bend the aluminium fin pack. Use a sweeping up and down motion in the direction of the vertical aluminium fin pack when pressure cleaning coils.

NOTE: It is extremely important to insure that none of the electrical and/or electronic parts of the unit get wet. Be sure to cover all electrical components to protect them from water or spray.

### Decorative Front

The decorative front and discharge air grille may be cleaned with a mild soap or detergent. Do NOT use solvents or hydrocarbon based cleaners such as acetone, naphtha, gasoline, benzene, etc., to clean the decorative front or air discharge grilles.

Use a damp (not wet) cloth when cleaning the control area to prevent water from entering the unit, and possibly damaging the electronic control.

### Fan Motor & Compressor

The fan motor & compressor and are permanently lubricated, and require no additional lubrication.

### Wall Sleeve

Inspect the inside of the wall sleeve and drain system periodically (annually or semi-annually) and clean as required.

Under extreme conditions, more frequent cleaning may be necessary. Clean both of these areas with an antibacterial and antifungal cleaner. Rinse both items thoroughly with water and ensure that the drain outlets are operating correctly. Check the sealant around the sleeve and reseal areas as needed.

# R-410A SEALED SYSTEM REPAIR

## ⚠ WARNING



### Refrigeration system under high pressure

Do not puncture, heat, expose to flame or incinerate.  
Only certified refrigeration technicians should service this equipment.  
R410A systems operate at higher pressures than R22 equipment. Appropriate safe service and handling practices must be used.  
Only use gauge sets designed for use with R410A. Do not use standard R22 gauge sets.

### The following is a list of important considerations when working with R-410A equipment

1. R-410A pressure is approximately 60% higher than R-22 pressure.
2. R-410A cylinders must not be allowed to exceed 125 F, they may leak or rupture.
3. R-410A must never be pressurized with a mixture of air, it may become flammable.
4. Servicing equipment and components must be specifically designed for use with R-410A and dedicated to prevent contamination.
5. Manifold sets must be equipped with gauges capable of reading 750 psig (high side) and 200 psig (low side), with a 500-psig low-side retard.
6. Gauge hoses must have a minimum 750-psig service pressure rating
7. Recovery cylinders must have a minimum service pressure rating of 400 psig, (DOT 4BA400 and DOT BW400 approved cylinders).
8. POE (Polyol-Ester) lubricants must be used with R-410A equipment.
9. To prevent moisture absorption and lubricant contamination, do not leave the refrigeration system open to the atmosphere longer than 1 hour.
10. Weigh-in the refrigerant charge into the high side of the system.
11. Introduce liquid refrigerant charge into the high side of the system.
12. For low side pressure charging of R-410A, use a charging adaptor.
13. Use industry standard R-410A filter dryers.

## ⚠ WARNING

EPA 608 Warning:  
It is a violation of the environmental Protection Agency, Claus608A, to service refrigeration systems without proper certification

## IMPORTANT

SEALED SYSTEM REPAIRS TO COOL-ONLY MODELS REQUIRE THE INSTALLATION OF A LIQUID LINE DRIER.

### EQUIPMENT REQUIRED:

1. Electrical Multimeter
2. E.P.A. Approved Refrigerant Recovery System
3. Vacuum Pump (capable of 200 microns or less vacuum.)
4. Acetylene Welder
5. Electronic Halogen Leak Detector capable of detecting HFC (Hydrofluorocarbon) refrigerants.
6. R410A Refrigerant Manifold
7. 1/4" Braze-type Access Ports
8. Pinch Tool
9. Refrigerant Scale
10. Vacuum Gauge - (0 - 1000 microns)
11. Facilities for flowing nitrogen through refrigeration tubing during all brazing processes.

### EQUIPMENT MUST BE CAPABLE OF:

1. Recovering refrigerant to EPA required levels.
2. Evacuation from both the high side and low side of the system simultaneously.
3. Introducing refrigerant charge into high side of the system.
4. Accurately weighing the refrigerant charge introduced into the system.

---

# R-410A SEALED SYSTEM REPAIRS

<b>⚠ WARNING</b>	
	<b>RISK OF ELECTRIC SHOCK</b> Unplug and/or disconnect all electrical power to the unit before performing inspections, maintenances or service.  Failure to do so could result in electric shock, serious injury or death.

<b>⚠ WARNING</b>	
	<b>HIGH PRESSURE HAZARD</b> Sealed Refrigeration System contains refrigerant and oil under high pressure.  Proper safety procedures must be followed, and proper protective clothing must be worn when working with refrigerants.  Failure to follow these procedures could result in serious injury or death.

## Refrigerant Charging

NOTE: Because the refrigerant system is a sealed system, service process tubes will have to be installed. First install a line tap and remove refrigerant from system. Make necessary sealed system repairs and vacuum system. Crimp process tube line and solder end shut. Do not leave a service valve in the sealed system.

Proper refrigerant charge is essential to proper unit operation. Operating a unit with an improper refrigerant charge will result in reduced performance (capacity) and/or efficiency. Accordingly, the use of proper charging methods during servicing will insure that the unit is functioning as designed and that its compressor will not be damaged.

Too much refrigerant (overcharge) in the system is just as bad (if not worse) than not enough refrigerant (undercharge). They both can be the source of certain compressor failures if they remain uncorrected for any period of time. Quite often, other problems (such as low air flow across evaporator, etc.) are misdiagnosed as refrigerant charge problems. The refrigerant circuit diagnosis chart will assist you in properly diagnosing the systems.

An overcharged unit will return liquid refrigerant (slugging) back to the suction side of the compressor eventually causing a mechanical failure within the compressor. This mechanical failure can manifest itself as valve failure, bearing failure, and/or other mechanical failure. The specific type of failure will be influenced by the amount of liquid being returned, and the length of time the slugging continues.

Not enough refrigerant (undercharge) on the other hand, will cause the temperature of the suction gas to increase to the point where it does not provide sufficient cooling for the compressor motor. When this occurs, the motor winding temperature will increase causing the motor to overheat and possibly cycle open the compressor overload protector. Continued overheating of the motor windings and/or cycling of the overload will eventually lead to compressor motor or overload failure.

# R-410A SEALED SYSTEM REPAIRS

<b>⚠ WARNING</b>	
	<b>RISK OF ELECTRIC SHOCK</b> Unplug and/or disconnect all electrical power to the unit before performing inspections, maintenances or service.  Failure to do so could result in electric shock, serious injury or death.

## Undercharged Refrigerant Systems

An undercharged system will result in poor performance (low pressures, etc.) in both the heating and cooling cycle.

Whenever you service a unit with an undercharge of refrigerant, always suspect a leak. The leak must be repaired before charging the unit.

To check for an undercharged system, turn the unit on, allow the compressor to run long enough to establish working pressures in the system (15 to 20 minutes).

During the cooling cycle you can listen carefully at the exit of the metering device into the evaporator; an intermittent hissing and gurgling sound indicates a low refrigerant charge. Intermittent frosting and thawing of the evaporator is another indication of a low charge, however, frosting and thawing can also be caused by insufficient air over the evaporator or partial restriction in the refrigeration system besides the metering device..

Checks for an undercharged system can be made at the compressor. If the compressor seems quieter than normal, it is an indication of a low refrigerant charge.

A check of the amperage drawn by the compressor motor should show a lower reading. (Check the Unit Specification.) After the unit has run 10 to 15 minutes, check the gauge pressures. Gauges connected to system with an undercharge will have low head pressures and substantially low suction pressures.

<b>⚠ WARNING</b>	
	<b>HIGH PRESSURE HAZARD</b> Sealed Refrigeration System contains refrigerant and oil under high pressure.  Proper safety procedures must be followed, and proper protective clothing must be worn when working with refrigerants.  Failure to follow these procedures could result in serious injury or death.

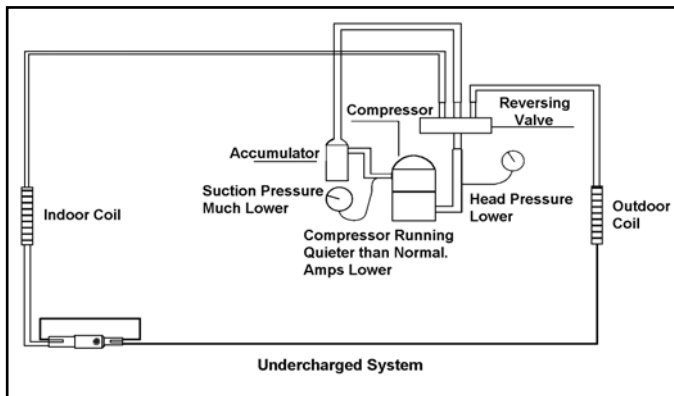



Figure 601 (Undercharged System)

# R-410A SEALED SYSTEM REPAIRS

<b>⚠ WARNING</b>	
	<b>RISK OF ELECTRIC SHOCK</b> Unplug and/or disconnect all electrical power to the unit before performing inspections, maintenances or service.
	Failure to do so could result in electric shock, serious injury or death.

## Overcharged Refrigerant Systems

Whenever an overcharged system is indicated, always make sure that the problem is not caused by air flow problems. Improper air flow over the evaporator coil may indicate some of the same symptoms as an overcharged system.

An overcharge can cause the compressor to fail, since it would be "slugged" with liquid refrigerant. The charge for any system is critical. When the compressor is noisy, suspect an overcharge, when you are sure that the air quantity over the evaporator coil is correct. Icing of the evaporator will not be encountered because the refrigerant will boil later if at all. Gauges connected to system will usually have higher head pressure (depending upon amount of over charge). Suction pressure should be slightly higher.

<b>⚠ WARNING</b>	
	<b>HIGH PRESSURE HAZARD</b> Sealed Refrigeration System contains refrigerant and oil under high pressure.
	Proper safety procedures must be followed, and proper protective clothing must be worn when working with refrigerants.
	Failure to follow these procedures could result in serious injury or death.

Compressor amps will be near normal or higher. Noncondensables can also cause these symptoms. To confirm, reclaim some of the charge, if conditions improve, system may be overcharged. If conditions don't improve, Noncondensables are indicated.

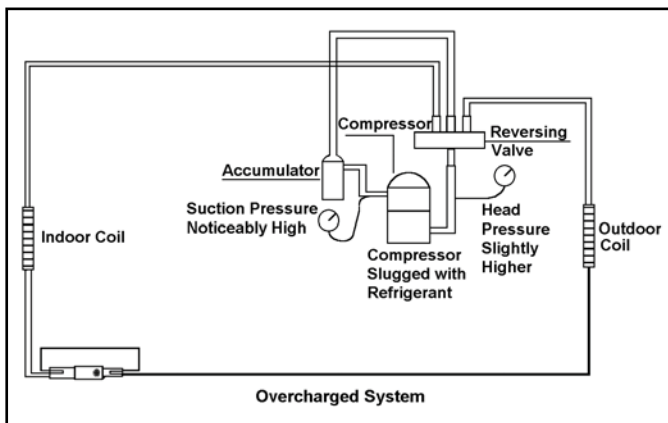

**Figure 602 (Overcharged System)**

# R-410A SEALED SYSTEM REPAIRS

## Restricted Refrigerant System

Troubleshooting a restricted refrigerant system can be difficult. The following procedures are the more common problems and solutions to these problems. There are two types of refrigerant restrictions: Partial restrictions and complete restrictions.

A partial restriction allows some of the refrigerant to circulate through the system.

With a complete restriction there is no circulation of refrigerant in the system. Restricted refrigerant systems display the same symptoms as a "low-charge condition."

When the unit is shut off, or the compressor disengages, the gauges may equalize very slowly.

A quick check for either condition begins at the evaporator. With a partial restriction, there may be gurgling sounds at the metering device entrance to the evaporator. The evaporator in a partial restriction could be partially frosted or have an ice ball close to the entrance of the metering device. Frost may continue on the suction line back to the compressor.

Often a partial restriction of any type can be found by feel, as there is a temperature difference from one side of the restriction to the other.

With a complete restriction, there will be no sound at the metering device entrance. An amperage check of the compressor with a partial restriction may show normal current when compared to the unit specification. With a complete restriction the current drawn may be considerably less than normal, as the compressor is running in a deep vacuum (no load.) Much of the area of the condenser will be relatively cool since most or all of the liquid refrigerant will be stored there.

The following conditions are based primarily on a system in the cooling mode.

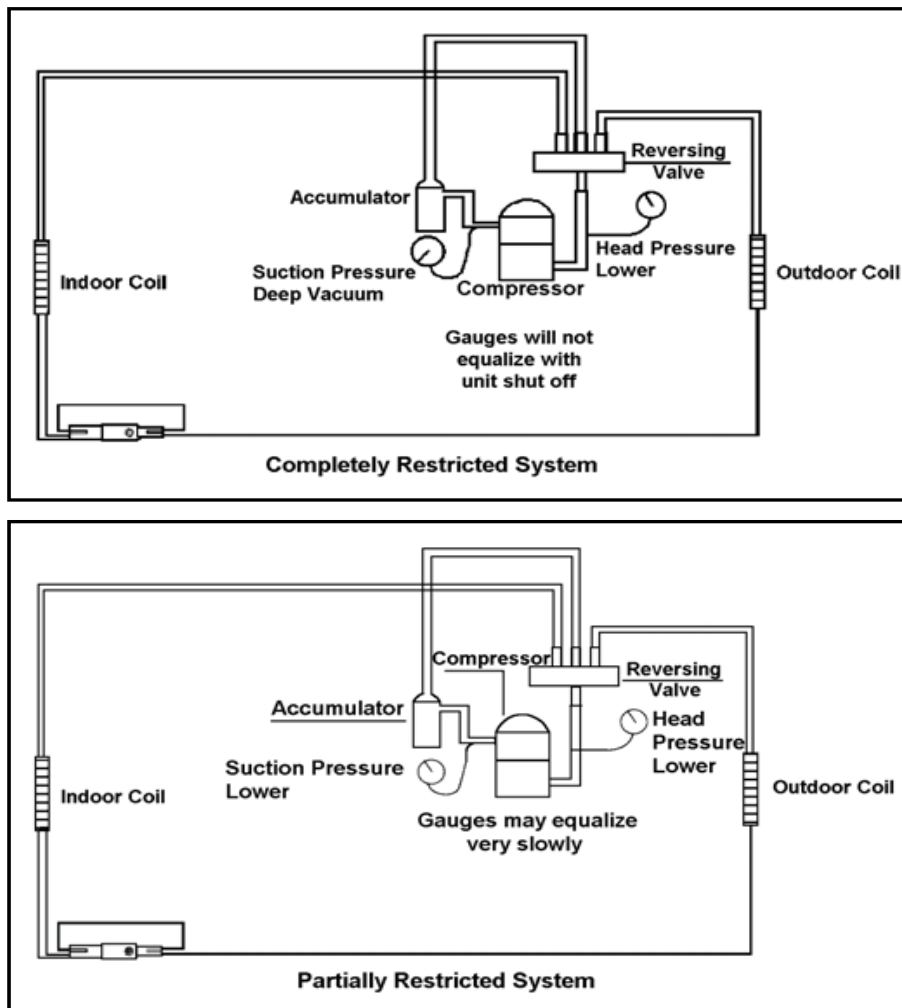



Figure 603 (Restricted System)

---

# R-410A SEALED SYSTEM REPAIRS

## Sealed System Method of Charging/ Repairs

<b>⚠ WARNING</b>		<b>⚠ CAUTION</b>	
	<b>BURN HAZARD</b> Proper safety procedures must be followed, and proper protective clothing must be worn when working with a torch.  Failure to follow these procedures could result in moderate or serious injury.		<b>FREEZE HAZARD</b> Proper safety procedures must be followed, and proper protective clothing must be worn when working with liquid refrigerant.  Failure to follow these procedures could result in minor to moderate injury.

The refrigerant cycle is critically charged. The only acceptable method for charging the sealed system is the Weighed in Charge Method.

The weighed in method should always be used whenever a charge is removed from a unit such as for a leak repair, compressor replacement, or when there is no refrigerant charge left in the unit. To charge by this method, requires the following steps:

1. Install a piercing valve to remove refrigerant from the sealed system. (Piercing valve must be removed from the system before recharging.)
2. Recover Refrigerant in accordance with EPA regulations.
3. Install a process tube to sealed system.
4. Make necessary repairs to system.
5. Evacuate system to 200 microns or less.
6. Weigh in refrigerant with the property quantity of R-410A refrigerant.
7. Start unit, and verify performance.
8. Crimp the process tube and solder the end shut.

# COMPONENT TESTING

## Hermetic Components Check

<b>⚠ WARNING</b>	
	<p><b>BURN HAZARD</b></p> <p>Proper safety procedures must be followed, and proper protective clothing must be worn when working with a torch.</p> <p>Failure to follow these procedures could result in moderate or serious injury.</p>

<b>⚠ WARNING</b>	
	<p><b>CUT/SEVER HAZARD</b></p> <p>Be careful with the sharp edges and corners. Wear protective clothing and gloves, etc.</p> <p>Failure to do so could result in serious injury.</p>

### Metering Device - Capillary Tube Systems

All units are equipped with capillary tube metering devices. Checking for restricted capillary tubes.

1. Connect pressure gauges to unit.
2. Start the unit in the cooling mode. If after a few minutes of operation the pressures are normal, the check valve and the cooling capillary are not restricted.
3. Switch the unit to the heating mode and observe the gauge readings after a few minutes running time. If the system pressure is lower than normal, the heating capillary is restricted.
4. If the operating pressures are lower than normal in both the heating and cooling mode, the cooling capillary is restricted.

### Check Valve

A unique two-way check valve is used on the reverse cycle heat pumps. It is pressure operated and used to direct the flow of refrigerant through a single filter drier and to the proper capillary tube during either the heating or cooling cycle.

**NOTE:** The slide (check) inside the valve is made of teflon. Should it become necessary to replace the check valve, place a wet cloth around the valve to prevent overheating during the brazing operation.

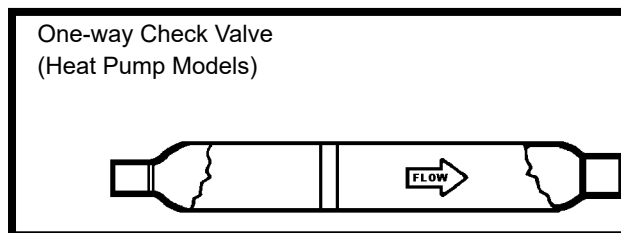

**Figure 701 (Check Valve)**

### CHECK VALVE OPERATION

In the cooling mode of operation, high pressure liquid enters the check valve forcing the slide to close the opposite port (liquid line) to the indoor coil. Refer to refrigerant flow chart. This directs the refrigerant through the filter drier and cooling capillary tube to the indoor coil.

In the heating mode of operation, high pressure refrigerant enters the check valve from the opposite direction, closing the port (liquid line) to the outdoor coil. The flow path of the refrigerant is then through the filter drier and heating capillary to the outdoor coil.

Failure of the slide in the check valve to seat properly in either mode of operation will cause flooding of the cooling coil. This is due to the refrigerant bypassing the heating or cooling capillary tube and entering the liquid line.

### COOLING MODE

In the cooling mode of operation, liquid refrigerant from condenser (liquid line) enters the cooling check valve forcing the heating check valve shut. The liquid refrigerant is directed into the liquid dryer after which the refrigerant is metered through cooling capillary tubes to evaporator. (Note: liquid refrigerant will also be directed through the heating capillary tubes in a continuous loop during the cooling mode).

### HEATING MODE

In the heating mode of operation, liquid refrigerant from the indoor coil enters the heating check valve forcing the cooling check valve shut. The liquid refrigerant is directed into the liquid dryer after which the refrigerant is metered through the heating capillary tubes to outdoor coils. (Note: liquid refrigerant will also be directed through the cooling capillary tubes in a continuous loop during the heating mode).

# COMPONENT TESTING

## Reversing Valve Description And Operation

The Reversing Valve controls the direction of refrigerant flow to the indoor and outdoor coils. It consists of a pressure-operated, main valve and a pilot valve actuated by a solenoid plunger. The solenoid is energized during the heating cycle only. The reversing valves used in the RAC system is a 2-position, 4-way valve.

The single tube on one side of the main valve body is the high-pressure inlet to the valve from the compressor. The center tube on the opposite side is connected to the low pressure (suction) side of the system. The other two are connected to the indoor and outdoor coils. Small capillary tubes connect each end of the main valve cylinder to the "A" and "B" ports of the pilot valve. A third capillary is a common return line from these ports to the suction tube on the main valve body. Four-way reversing valves also have a capillary tube from the compressor discharge tube to the pilot valve.

The piston assembly in the main valve can only be shifted by the pressure differential between the high and low sides of the system. The pilot section of the valve opens and closes ports for the small capillary tubes to the main valve to cause it to shift.

**NOTE: System operating pressures must be near normal before valve can shift.**

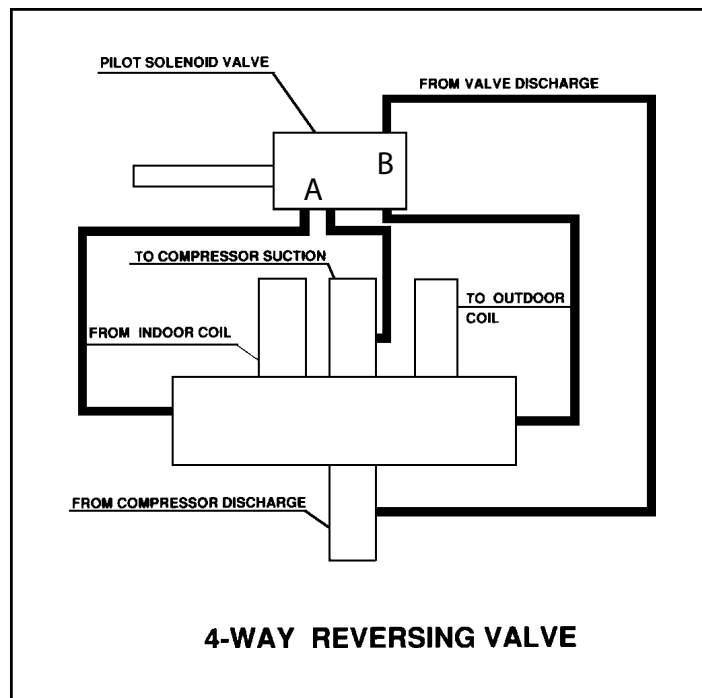

Figure 702 (Reversing Valve)

---

# COMPONENT TESTING

## Testing The Reversing Valve Solenoid Coil



The solenoid coil is an electromagnetic type coil mounted on the reversing valve and is energized during the operation of the compressor in the heating cycle.

1. Turn off high voltage electrical power to unit.
2. Unplug line voltage lead from reversing valve coil.
3. Check for electrical continuity through the coil. If you do not have continuity replace the coil.
4. Check from each lead of coil to the copper liquid line as it leaves the unit or the ground lug. There should be no continuity between either of the coil leads and ground; if there is, coil is grounded and must be replaced.
5. If coil tests okay, reconnect the electrical leads.
6. Make sure coil has been assembled correctly.

**NOTE: Do not start unit with solenoid coil removed from valve, or do not remove coil after unit is in operation. This will cause the coil to burn out.**

### Touch Test in Heating/Cooling Cycle

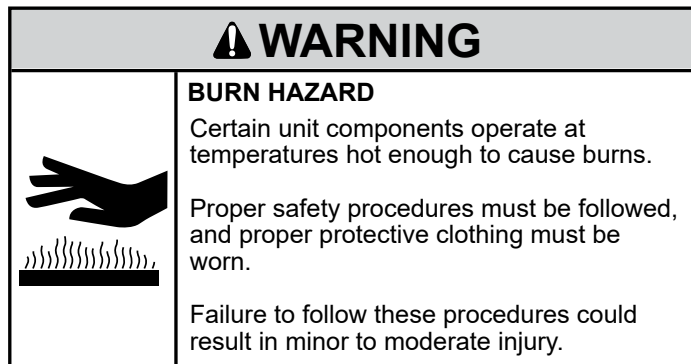

The only definite indications that the slide is in the mid-position is if all three tubes on the suction side of the valve are hot after a few minutes of running time.

**NOTE:** If both tubes shown as hot or cool are not the same corresponding temperature, refer to figure 703, then the reversing valve is not shifting properly.

# COMPONENT TESTING

## Checking The Reversing Valve

<b>⚠ WARNING</b>	
	<b>HIGH PRESSURE HAZARD</b> Sealed Refrigeration System contains refrigerant and oil under high pressure.
	Proper safety procedures must be followed, and proper protective clothing must be worn when working with refrigerants.
	Failure to follow these procedures could result in serious injury or death.

**NOTE: You must have normal operating pressures before the reversing valve can shift.**

Check the operation of the valve by starting the system and switching the operation from “Cooling” to “Heating” and then back to “Cooling”. Rapidly cycle. Do not hammer on valve.

Occasionally, the reversing valve may stick in the heating or cooling position or in the mid-position. When sluggish or stuck in the mid-position, part of the discharge gas from the compressor is directed back to the suction side, resulting in excessively high suction pressure.

Should the valve fail to shift from cooling to heating, block the air flow through the outdoor coil and allow the discharge pressure to build in the system. Then switch the system from heating to cooling.

If the valve is stuck in the heating position, block the air flow through the indoor coil and allow discharge pressure to build in the system. Then switch the system from heating to cooling.

Should the valve fail to shift in either position after increasing the discharge pressure, replace the valve.

Dented or damaged valve body or capillary tubes can prevent the main slide in the valve body from shifting. If you determine this is the problem, replace the reversing valve.

After all of the previous inspections and checks have been made and determined correct, then perform the “Touch Test” on the reversing valve.

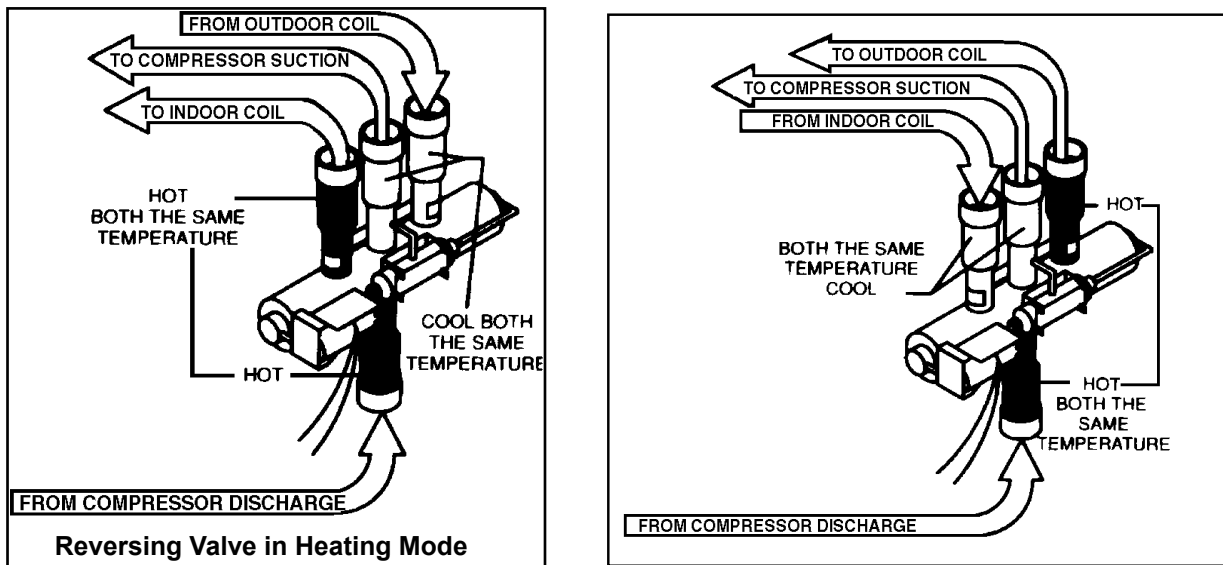



Figure 703 (Checking The Reversing Valve)

# COMPONENT TESTING

## Replace The Reversing Valve

<b>⚠ WARNING</b>	
	<b>HIGH PRESSURE HAZARD</b> Sealed Refrigeration System contains refrigerant and oil under high pressure.
	Proper safety procedures must be followed, and proper protective clothing must be worn when working with refrigerants.
	Failure to follow these procedures could result in serious injury or death.

<b>NOTICE</b>
<b>FIRE HAZARD</b> The use of a torch requires extreme care and proper judgment. Follow all safety recommended precautions and protect surrounding areas with fire proof materials. Have a fire extinguisher readily available. Failure to follow this notice could result in moderate to serious property damage.

1. Install Process Tubes. Recover refrigerant from sealed system. PROPER HANDLING OF RECOVERED REFRIGERANT ACCORDING TO EPA REGULATIONS IS REQUIRED.
2. Remove solenoid coil from reversing valve. If coil is to be reused, remove solenoid and protect from heat while changing valve.
3. Unbrazed all lines from reversing valve.
4. Clean all excess braze from all tubing so that they will slip into fittings on new valve.
5. Remove solenoid coil from new valve.
6. Protect new valve body from heat while brazing with plastic heat sink (Thermo Trap) or wrap valve body with wet rag.
7. Fit all lines into new valve and braze lines into new valve.

<b>⚠ WARNING</b>	
	<b>EXPLOSION HAZARD</b> The use of nitrogen requires a pressure regulator. Follow all safety procedures and wear protective safety clothing etc.
	Failure to follow proper safety procedures could result in serious injury or death.

8. Pressurize sealed system with a combination of R-410A and nitrogen. Pressurize system to 550 psi and triple evacuate. Check for leaks, using a suitable leak detector. Recover refrigerant per EPA guidelines.
9. Once the sealed system is leak free, install solenoid coil on new valve and charge the sealed system by weighing in the proper amount and type of refrigerant as shown on rating plate. Crimp the process tubes and solder the ends shut. Do not leave Schrader or piercing valves in the sealed system.

**NOTE: When brazing a reversing valve into the system, it is of extreme importance that the temperature of the valve does not exceed 250°F at any time.**

Wrap the reversing valve with a large rag saturated with water. "Re-wet" the rag and thoroughly cool the valve after each brazing operation of the four joints involved.

The wet rag around the reversing valve will eliminate conduction of heat to the valve body when brazing the line connection.

# COMPONENT TESTING

## Touch Test Chart : To Service Reversing Valves

NORMAL FUNCTION OF VALVE								
VALVE OPERATING CONDITION	DISCHARGE TUBE from Compressor	SUCTION TUBE	COIL	Tube to OUTSIDE COIL	LEFT Pilot	RIGHT Pilot	NOTES:	
	1	2	3	4	5	6	* TEMPERATURE OF VALVE BODY ** WARMER THAN VALVE BODY	
							POSSIBLE CAUSES      CORRECTIONS	
Normal Cooling	Hot	Cool	Cool as (2)	Hot as (1)	*TVB	TVB		
Normal Heating	Hot	Cool	Hot as (1)	Cool as (2)	*TVB	TVB		
MALFUNCTION OF VALVE								
Valve will not shift from cool to heat.	Check Electrical circuit and coil						No voltage to coil.	Repair electrical circuit.
							Defective coil.	Replace coil.
	Check refrigeration charge						Low charge.	Repair leak, recharge system.
							Pressure differential too high.	Recheck system.
	Hot	Cool	Cool, as (2)	Hot, as (1)	*TVB	Hot	Pilot valve okay. Dirt in one bleeder hole.	Deenergize solenoid, raise head pressure, reenergize solenoid to break dirt loose. If unsuccessful, remove valve, wash out. Check on air before installing. If no movement, replace valve, add strainer to discharge tube, mount valve horizontally.
						Piston cup leak	Stop unit. After pressures equalize, restart with solenoid energized. If valve shifts, reattempt with compressor running. If still no shift, replace valve.	
Valve will not shift from cool to heat.	Hot	Cool	Cool, as (2)	Hot, as (1)	*TVB	*TVB	Clogged pilot tubes.	Raise head pressure, operate solenoid to free. If still no shift, replace valve.
	Hot	Cool	Cool, as (2)	Hot, as (1)	Hot	Hot	Both ports of pilot open. (Back seat port did not close).	Raise head pressure, operate solenoid to free partially clogged port. If still no shift, replace valve.
	Warm	Cool	Cool, as (2)	Hot, as (1)	*TVB	Warm	Defective Compressor.	Replace compressor
Starts to shift but does not complete reversal.	Hot	Warm	Warm	Hot	*TVB	Hot	Not enough pressure differential at start of stroke or not enough flow to maintain pressure differential.	Check unit for correct operating pressures and charge. Raise head pressure. If no shift, use valve with smaller port.
							Body damage.	Replace valve
	Hot	Warm	Warm	Hot	Hot	Hot	Both ports of pilot open.	Raise head pressure, operate solenoid. If no shift, use valve with smaller ports.
	Hot	Hot	Hot	Hot	*TVB	Hot	Body damage.	Replace valve
							Valve hung up at mid-stroke. Pumping volume of compressor not sufficient to maintain reversal.	Raise head pressure, operate solenoid. If no shift, use valve with smaller ports.
Apparent leap in heating.	Hot	Cool	Hot, as (1)	Cool, as (2)	*TVB	*TVB	Piston needle on end of slide leaking.	Operate valve several times, then recheck. If excessive leak, replace valve.
	Hot	Cool	Hot, as (1)	Cool, as (2)	**WVB	**WVB	Pilot needle and piston needle leaking.	Operate valve several times, then recheck. If excessive leak, replace valve.
Will not shift from heat to cool.	Hot	Cool	Hot, as (1)	Cool, as (2)	*TVB	*TVB	Pressure differential too high.	Stop unit. Will reverse during equalization period. Recheck system
							Clogged pilot tube.	Raise head pressure, operate solenoid to free dirt. If still no shift, replace valve.
	Hot	Cool	Hot, as (1)	Cool, as (2)	Hot	*TVB	Dirt in bleeder hole.	Raise head pressure, operate solenoid. Remove valve and wash out. Check on air before reinstalling, if no movement, replace valve. Add strainer to discharge tube. Mount valve horizontally.
	Hot	Cool	Hot, as (1)	Cool, as (2)	Hot	*TVB	Piston cup leak.	Stop unit. After pressures equalize, restart with solenoid deenergized. If valve shifts, reattempt with compressor running. If it still will not reverse while running, replace the valve.
	Hot	Cool	Hot, as (1)	Cool, as (2)	Hot	Hot	Defective pilot.	Replace valve.
	Warm	Cool	Warm, as (1)	Cool, as (2)	Warm	*TVB	Defective compressor.	Replace compressor

Figure 704 (Touch Test Chart)

# COMPONENT TESTING

## Compressor Checks

⚠ WARNING	
	<b>ELECTRIC SHOCK HAZARD</b> Turn off electric power before service or installation. All electrical connections and wiring <b>MUST</b> be installed by a qualified electrician and conform to the National Electrical Code and all local codes which have jurisdiction. Failure to do so can result in personal injury or death.

⚠ WARNING	
	<b>BURN HAZARD</b> Proper safety procedures must be followed, and proper protective clothing must be worn when working with a torch. Failure to follow these procedures could result in moderate or serious injury.

### Locked Rotor Voltage (L.R.V.) Test

Locked rotor voltage (L.R.V.) is the actual voltage available at the compressor under a stalled condition.

### Single Phase Connections

Disconnect power from unit. Using a voltmeter, attach one lead of the meter to the run “R” terminal on the compressor and the other lead to the common “C” terminal of the compressor. Restore power to unit.

### Determine L.R.V.

Start the compressor with the volt meter attached; then stop the unit. Attempt to restart the compressor within a couple of seconds and immediately read the voltage on the meter. The compressor under these conditions will not start and will usually kick out on overload within a few seconds since the pressures in the system will not have had time to equalize. Voltage should be at or above minimum voltage of 197 VAC, as specified on the rating plate. If less than minimum, check for cause of inadequate power supply; i.e., incorrect wire size, loose electrical connections, etc.

### Amperage (R.L.A) Test

The running amperage of the compressor is the most important of these readings. A running amperage higher than that indicated in the performance data indicates that a problem exists mechanically or electrically.

### Single Phase Running and L.R.A. Test

**NOTE:** Consult the specification and performance section for running amperage. The L.R.A. can also be found on the rating plate. Select the proper amperage scale and clamp the meter probe around the wire to the “C” terminal of the compressor. Turn on the unit and read the running amperage on the meter. If the compressor does not start, the reading will indicate the locked rotor amperage (L.R.A.).

### Overloads

The compressor is equipped with either an external or internal overload which senses both motor amperage and winding temperature. High motor temperature or amperage heats the overload causing it to open, breaking the common circuit within the compressor. Heat generated within the compressor shell, usually due to recycling of the motor, is slow to dissipate. It may take anywhere from a few minutes to several hours for the overload to reset.

### Checking the Overloads

#### External Overloads

With power off, remove the leads from compressor terminals. If the compressor is hot, allow the overload to cool before starting check. Using an ohmmeter, test continuity across the terminals of the external overload. If you do not have continuity; this indicates that the overload is open and must be replaced.

#### Internal Overloads

The overload is embedded in the motor windings to sense the winding temperature and/or current draw. The overload is connected in series with the common motor terminal.

Should the internal temperature and/or current draw become excessive, the contacts in the overload will open, turning off the compressor. The overload will automatically reset, but may require several hours before the heat is dissipated.

**NOTE: The overload will automatically reset, but may require several hours before the heat is dissipated. Ensure that compressor overload switch has been rechecked after it cools down, before replacing compressor.**

#### Checking the Internal Overload

1. With no power to unit, remove the leads from the compressor terminals.
2. Using an ohmmeter, test continuity between terminals C-S and C-R. If no continuity, the compressor overload is open and the compressor must be replaced.

# COMPONENT TESTING

## Compressor Checks

<b>⚠ WARNING</b>	
	<b>ELECTRIC SHOCK HAZARD</b> Turn off electric power before service or installation. Extreme care must be used, if it becomes necessary to work on equipment with power applied.
	Failure to do so could result in serious injury or death.

<b>⚠ WARNING</b>	
	<b>HIGH PRESSURE HAZARD</b> Sealed Refrigeration System contains refrigerant and oil under high pressure.
	Proper safety procedures must be followed, and proper protective clothing must be worn when working with refrigerants.  Failure to follow these procedures could result in serious injury or death.

### Single Phase Resistance Test

Remove the leads from the compressor terminals and set the ohmmeter on the lowest scale [R x 1].

Touch the leads of the ohmmeter from terminals common to start ("C" to "S"). Next, touch the leads of the ohmmeter from terminals common to run ("C" to "R").

Add values "C" to "S" and "C" to "R" together and check resistance from start to run terminals ("S" to "R"). Resistance "S" to "R" should equal the total of "C" to "S" and "C" to "R."

In a single phase PSC compressor motor, the highest value will be from the start to the run connections ("S" to "R"). The next highest resistance is from the start to the common connections ("S" to "C"). The lowest resistance is from the run to common. ("C" to "R") Before replacing a compressor, check to be sure it is defective.

### GROUND TEST

Use an ohmmeter set on its highest scale. Touch one lead to the compressor body (clean point of contact as a good connection is a must) and the other probe in turn to each compressor terminal. If a reading is obtained the compressor is grounded and must be replaced.

Check the complete electrical system to the compressor and compressor internal electrical system, check to be certain that compressor is not out on internal overload.

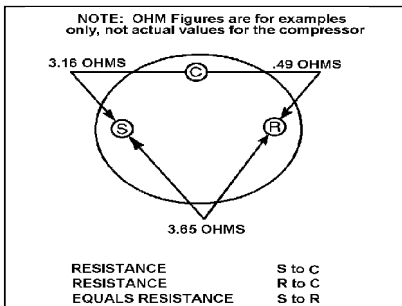

**Figure 705 (Resistance Chart)**

Complete evaluation of the system must be made whenever you suspect the compressor is defective. If the compressor has been operating for sometime, a careful examination must be made to determine why the compressor failed.

Many compressor failures are caused by the following conditions:

1. Improper air flow over the evaporator.
2. Overcharged refrigerant system causing liquid to be returned to the compressor.
3. Restricted refrigerant system.
4. Lack of lubrication.
5. Liquid refrigerant returning to compressor causing oil to be washed out of bearings.
6. Noncondensables such as air and moisture in the system. Moisture is extremely destructive to a refrigerant system.
7. Capacitor.

### CHECKING COMPRESSOR EFFICIENCY

The reason for compressor inefficiency is normally due to broken or damaged suction and/or discharge valves, reducing the ability of the compressor to pump refrigerant gas.

This condition can be checked as follows:

1. Install a piercing valve on the suction and discharge or liquid process tube.
2. Attach gauges to the high and low sides of the system.-
3. Start the system to operate the compressor and run a "cooling or heating performance test." If test shows:
  - A. Below normal high side pressure
  - B. Above normal low side pressure
  - C. Low temperature difference across coil

The compressor valves are faulty - replace the compressor.

# COMPONENT TESTING

## Compressor Replacement

<b>⚠ WARNING</b>	
	<p><b>ELECTRIC SHOCK HAZARD</b> Turn off electric power before service or installation. Extreme care must be used, if it becomes necessary to work on equipment with power applied.</p> <p>Failure to do so could result in serious injury or death.</p>

<b>⚠ WARNING</b>	
	<p><b>HIGH PRESSURE HAZARD</b> Sealed Refrigeration System contains refrigerant and oil under high pressure.</p> <p>Proper safety procedures must be followed, and proper protective clothing must be worn when working with refrigerants.</p> <p>Failure to follow these procedures could result in serious injury or death.</p>

<b>⚠ WARNING</b>	
	<p><b>EXPLOSION HAZARD</b> The use of nitrogen requires a pressure regulator. Follow all safety procedures and wear protective safety clothing etc.</p> <p>Failure to follow proper safety procedures could result in serious injury or death.</p>

<b>⚠ CAUTION</b>	
	<p><b>FREEZE HAZARD</b> Proper safety procedures must be followed, and proper protective clothing must be worn when working with liquid refrigerant.</p> <p>Failure to follow these procedures could result in minor to moderate injury.</p>

1. Be certain to perform all necessary electrical and refrigeration tests to be sure the compressor is actually defective before replacing.

2. Recover all refrigerant from the system through the process tubes. **PROPER HANDLING OF RECOVERED REFRIGERANT ACCORDING TO EPA REGULATIONS IS REQUIRED.** Do not use gauge manifold for this purpose if there has been a burnout. You will contaminate your manifold and hoses. Use a Schrader valve adapter and copper tubing for burnout failures.

3. After all refrigerant has been recovered, disconnect suction and discharge lines from the compressor and remove compressor. Be certain to have both suction and discharge process tubes open to atmosphere.

4. Carefully pour a small amount of oil from the suction stub of the defective compressor into a clean container.

5. Using an acid test kit (one shot or conventional kit), test the oil for acid content according to the instructions with the kit.

6. If any evidence of a burnout is found, no matter how slight, the system will need to be cleaned up following proper procedures.

7. Install the replacement compressor.

8. Pressurize with a combination of R-410A and nitrogen and leak test all connections with an electronic or Halide leak detector. Recover refrigerant and repair any leaks found.

8a. If leak detector is unavailable remove all refrigerant from system and pressurize with nitrogen to 350 psi. Check that system holds pressure.

Repeat Step 8 to insure no more leaks are present



9. Evacuate the system with a good vacuum pump capable of a final vacuum of 200 microns or less. The system should be evacuated through both liquid line and suction line gauge ports. While the unit is being evacuated, seal all openings on the defective compressor. Compressor manufacturers will void warranties on units received not properly sealed. Do not distort the manufacturers tube connections.



10. Recharge the system with the correct amount of refrigerant. The proper refrigerant charge will be found on the unit rating plate. The use of an accurate measuring device, such as a charging cylinder, electronic scales or similar device is necessary.

# COMPONENT TESTING



## Compressor Replacement -Special Procedure in Case of Compressor Burnout

1. Recover all refrigerant and oil from the system.
2. Remove compressor, capillary tube and filter drier from the system.
3. Flush evaporator condenser and all connecting tubing with dry nitrogen or equivalent. Use approved flushing agent to remove all contamination from system. Inspect suction and discharge line for carbon deposits. Remove and clean if necessary. Ensure all acid is neutralized.
4. Reassemble the system, including new drier strainer and capillary tube.
5. Pressurize with a combination of R-410A and nitrogen and leak test all connections with an electronic or Halide leak detector. Recover refrigerant and repair any leaks found.
- 5a. If leak detector is unavailable remove all refrigerant from system and pressurize with nitrogen to 350 psi. Check that system holds pressure.

 <b>WARNING</b>	
	<b>HIGH PRESSURE HAZARD</b> Sealed Refrigeration System contains refrigerant and oil under high pressure.
	Proper safety procedures must be followed, and proper protective clothing must be worn when working with refrigerants.
	Failure to follow these procedures could result in serious injury or death.

 <b>WARNING</b>	
	<b>ELECTRIC SHOCK HAZARD</b> Turn off electric power before service or installation. Extreme care must be used, if it becomes necessary to work on equipment with power applied.
	Failure to do so could result in serious injury or death.

 <b>WARNING</b>	
	<b>EXPLOSION HAZARD</b> The use of nitrogen requires a pressure regulator. Follow all safety procedures and wear protective safety clothing etc.
	Failure to follow proper safety procedures could result in serious injury or death.

 <b>WARNING</b>	
	<b>NEVER</b> , under any circumstances, liquid charge a rotary-compressor through the LOW side. Doing so would cause permanent damage to the new compressor. Use a charging adapter.

Repeat Step 5 to insure no more leaks are present

6. Evacuate the system with a good vacuum pump capable of a final vacuum of 200 microns or less. The system should be evacuated through both liquid line and suction line gauge ports. While the unit is being evacuated, seal all openings on the defective compressor. Compressor manufacturers will void warranties on units received not properly sealed. Do not distort the manufacturers tube connections.

7. Recharge the system with the correct amount of refrigerant. The proper refrigerant charge will be found on the unit rating plate. The use of an accurate measuring device, such as a charging cylinder, electronic scales or similar device is necessary.

### ROTARY AND SCROLL COMPRESSOR SPECIAL TROUBLESHOOTING AND SERVICE

Troubleshooting and servicing rotary compressors is basically the same as on the reciprocating compressor with only one main exception:

# TROUBLESHOOTING

## Basic Troubleshooting

Malfunction	Possible Reasons	Solution
Start Failure	Power Supply interrupted	Check the indicator LED on the LCID power head, it should be lit up, if not, push the RESET button, if still don't have voltage, but power grid has output, you need to change the power cord.
	Power cord protection trip.	Check the power cord if somewhere is broken, push the RESET button. If not solved, replace the power cord.
	Power cord loose	Ensure that the power supply is plugged in correctly
	PCB fuse is broken.	Check if any load (in fan, out fan, reversing valve, power transformer) is short circuit. Eliminate the error and replace the fuse with the same type.
	Bad contact between main board and control panel.	Check the contact wires, make sure all contact well.
	Compressor delay start.	It's normal, compressor will start after 3 minutes
	Power fail protection.	When power on, because of auto-restart, unit will delay starting in 120~240s
	Unit in protection mode.	Please check the ERROR CODE
	Main board or Control panel is bad.	Replace the main board or control panel
Control panel do not work	When the unit is switched to 24v remote thermostat, the control panel will not function	If you are switching over to remote thermostat, the control settings need to be changed. See the advanced settings section of this manual
Indoor / outdoor fan does not function or runs slowly	The fan has an object lodged in it, or the power wires are loose. Fan capacitor has malfunctioned or the wires are loose.	Disconnect power and check if the fan spins freely by hand. Ensure that motor and capacitor wires are connected correctly. If motor is running slowly, replace capacitor.
Insufficient cooling/ heating	Something may block the indoor/outdoor air outlet.	Make sure that there is no obstacle at the indoor/outdoor air outlet. Make sure that the grill is suitable for the unit, inappropriate grill will cause the compressor being protected; make sure that the grill has more than 70% turnover.
	Set unsuitable temperature.	Set higher/lower temperature by the control board. NOTE: temperature setting restriction will restrict the setting temperature. See the Setting Temperature Range chapter.
	Indoor air filter is dirty.	Should clean the filter every month at least.
	Room is hot/cold.	Let unit run a little longer that room temperature will be lower/higher.
	Heat leakage between indoor and outdoor.	Block the leakage place.
	Indoor coil not cold/heat.	Charge the refrigerant.
	Unit has noise	Check that there aren't any obstructions in the airway, or that no moving parts have loosened up.
Bad smell when heating	The dust on the E-heater is heating.	The bad smell will disappear a little later.

# TROUBLESHOOTING

## Basic Troubleshooting

Malfunction	Possible Reasons	Solution
Outlet temperature is not always cooling/heating	Outlet temperature is not high enough when heating by heat pump.	When outdoor ambient temp is low, the heat pump will not be able to offer enough heat. Soon after that, the E-heater will come on to heat.
	Fan stops when cooling/heating.	It is normal when the CONSTANT FAN is OFF. You can enable the CONSTANT FAN.
Outdoor is dripping water	Not install the drain pipe kit.	Install the drain pipe kit.
Indoor is dripping water	Wall sleeve is not installed correctly.	Install the wall sleeve according to the installation manual.
Indoor coil freeze	Outdoor temperature is too low in cooling mode.	When outdoor temperature is drop to 12.8°C (55 °F) or below, it will cause that indoor coil freeze. Open the fresh air door, and running at fan mode.
	Filter is dirty.	Clean the filter to recover the normal air flow
E2 Indoor return air temperature sensor failure	Indoor return air temperature sensor open circuit or short circuit.	Check the sensor connecting. If the sensor is bad, replace a new one.
E3 Indoor coil temperature sensor failure	Indoor coil temperature sensor open circuit or short circuit.	Check the sensor connecting. If the sensor is bad, replace a new one.
E4 indoor air outlet temperature sensor failure/air blow out over heat in electric heat mode	Indoor air outlet temperature sensor open circuit or short circuit; Indoor filter gets dirty or something blocks the air intake.	Check the sensor connecting. If the sensor is bad, replace a new one. Clean the filter and clean the air way.
E5 Outdoor coil temperature sensor failure.	Outdoor coil temperature sensor open circuit or short circuit.	Check the sensor connecting. If the sensor is bad, replace a new one.
E8 Overheating protection/defrosting	Indoor fan failure/dirty filter/refrigerating system failure/indoor coil temperature sensor failure.	Check the indoor fan/clean filter/refill refrigerant/replace indoor coil sensor.
E9 High pressure protection	Outdoor fan failure/refrigerating system failure/high pressure switch failure/outdoor coil temp sensor broken.	Check outdoor fan/refrigerating pipe system/high pressure switch/outdoor coil temp sensor.

## Service & Assistance

Before calling for service, please check the "Basic Troubleshooting" section above. This may help you to the answer to your problem, avoid unnecessary service calls, and save you the cost of a service call if the problem is not due to the product itself. If you have checked the "Basic Troubleshooting" section and still need help, here is a list of available services:

You can find the name of your local Authorized Service Provider by visiting our web site at [www.friedrich.com](http://www.friedrich.com).

If you require further assistance you can call the Customer Support Call Center at 1-800-541-6645.

Before calling, please make sure that you have the complete model and serial number, and date of purchase of your equipment available. By providing us with this information we will be better able to assist you.

Our specialists are able to assist you with:

- \* Inspect and ensure that all components and accessories have been installed properly and that they have not been damaged during the installation.
- \* Specifications and Features of our equipment.
- \* Referrals to dealers, and distributors.
- \* Use and Care information.
- \* Recommended maintenance procedures.
- \* Installation information.
- \* Referrals to Authorized Service Providers and Parts depots.

# TROUBLESHOOTING

## Malfunction Analysis

Malfunction	Possible Reasons	How to solve
Start Failure	power line broken, units without power supply	"Check the indicator LED on the LCID power head, and it should be lit up ;if not, push the RESET button, if no voltage still, but power grid has output, you need to change the power cord." See figure 701
	Power cord protection trip	"Check the power cord .If damaged, replaced. If no damage noted, push the RESET button. If still not solved, replace the power cord."
	Power cord not plugged in correctly	Seat plug correctly..
	PCB fuse broken	"Check if any load (in fan, out fan, reversing valve, power transformer) has a short circuit. Eliminate the error and replace the fuse with the same type."
	Bad connection between main board and control panel	Check connecting wires, making sure all are connected well.
	Compressor delay start	If it's normal, compressor will start after 3 minutes.
	Power fail protection	"When power on, because of auto-restart, unit will delay starting in 120~240s"
	Unit in protection mode	Please check the ERROR CODE.
	Main board or Control panel broken	Replace main board or control panel.
Control panel do not work	When switching to 24V remote thermostat, the control panel will not function.	"If you need to use control panel to take control, you need to switch the control mode. See Switch Over Between 24V Remote Thermostat and Control Panel in the advanced settings section."See Figure 702
Indoor fan/outdoor fan does not function or run slowly	Fan is locked by something or the power wires are not correctly connected; fan capacitor terminals loose; fan capacitor is out of service life	Disconnect the power cord, check whether the fan can run smoothly by hand or other tools or whether motor wire is fixed well. If fan runs slow, replace capacitor..

# TROUBLESHOOTING

## Malfunction Analysis

Malfunction	Possible Reasons	How to solve
Insufficient cooling/heating		"Make sure that there is no obstacle at the indoor/ outdoor air outlet."
	Something may block the indoor/outdoor air outlet	"Make sure that the grill is suitable for the unit. Inappropriate grill will cause the compressor under protection mode. Make sure ventilation rate of grille over 70% in the case of area."
	Set unsuitable temperature	"Set higher/lower temperature by the control board. NOTE: temperature setting restriction will restrict the setting temperature. See the Setting Temperature Range chapter."
	Indoor air filter dirty	Should clean the filter every month at least.
	Room hot/cold	"Let unit run a little longer that room temperature will be lower/higher."
	Heat leakage between indoor and outdoor	Block the leakage place.
	Indoor coil not cold/heat	Charge refrigerant.
Unit has noise	"Some moving parts of the unit have become loose or cause bad vibration. Something is in the air way."	Make sure that all moving parts are assembled well, and nothing is in the air way.
Bad smell when heating	The dust on the E-heater is heating	The bad smell will disappear a little later.
Outlet air not always cool/warm	Outlet temperature is not high enough when heating by heat pump	"When outdoor ambient temp is low, the heat pump will not be able to offer enough heat. Soon after that, the E-heater will come on to heat."
	Fan stops when cooling/heating	It is normal when the CONSTANT FAN is OFF. You can enable the CONSTANT FAN.
Outdoor is dripping water.	Drain pipe kit hasn't been installed.	Install the drain pipe kit.
Indoor is dripping water.	Wall sleeve is not installed correctly.	"Install the wall sleeve according to the installation manual."
Indoor coil freeze.	Outdoor temperature is too low in cooling mode	"When outdoor temperature drops to 55°F(12.8°C) or below, it will cause indoor coil to freeze. Open the fresh air door, and running at fan mode."
	Filter dirty	Clean the filter to recover the normal air flow
E2 Indoor return air temperature sensor failure	Indoor return air temperature sensor open circuit or short circuit	Check whether the plug is firmly connected. If the sensor is broken,replace it. See figure 703.
E3 Indoor coil temperature sensor failure	Indoor coil temperature sensor open circuit or short circuit	Check the sensor connection. If the sensor is bad, replace with a new one. See figure 703.

# TROUBLESHOOTING

## Malfunction Analysis

Malfunction	Possible Reasons	How to solve
"E4 indoor air outlet temperature sensor failure/air blow out over heat in electric heat mode"	"Indoor air outlet temperature sensor open circuit or short circuit; Indoor filter gets dirty or something blocks the air intake."	"Check the sensor connection. If the sensor is broken, replace with a new one. Clean the filter and clean the air way." See figures 703 and 704.
E5 Outdoor coil temperature sensor failure.	Outdoor coil temperature sensor open circuit or short circuit	Check the sensor connection. If the sensor broken, replace with a new one. See figure 703.
E8 Overheat protection/defrosting	"Indoor fan failure/dirty filter/refrigerating system failure/indoor coil temperature sensor failure"	Check the indoor fan/clean filter/refill refrigerant/replace indoor coil sensor. See figure 705 -710
E9 High pressure protection.	"Outdoor fan failure/refrigerating system failure/high pressure switch failure/outdoor coil temp sensor broken"	"Check outdoor fan/refrigerating pipe system/high pressure switch/outdoor coil temp sensor."

---

# TROUBLESHOOTING

## Unit Lost Power

Check power cord connection.

LED on the plug should be lit up green. If not, press the RESET button. If not solved, check voltage in the socket. If the power-cord is broken, replace it.



Figure 701

---

# TROUBLESHOOTING

## Control Panel Does Not Work

1. Check Power Supply for appropriate voltage.
2. If the power supply voltage is OK, but the control panel does not work, the 24V thermostat could be faulty. Check the thermostat.
3. To check the control panel, press and hold the [Cool] and [up] keys simultaneously for 5 seconds. LED will show 'P' character. If the panel has a strange character displayed, the PCB inside is faulty. Replace the control panel.



Figure 702

# TROUBLESHOOTING

## Malfunction of Temperature Sensor

E2/E3/E4/E5

These 4 errors may be the result of the sensor getting lose or becoming broken.

Unplug the power cord, open the electric control box, find the main board, connect these plugs firmly.

If the problem persists check the resistance of the sensors. Refer to thermistor resistance chart in the appendix of this manual..

E2 for 'blue' marks T1.

E3 for 'white' marks T2.

E5 for 'black' marks T3.

E4 for 'red' marks T4.

If the sensors resistance check is good, replace the board.

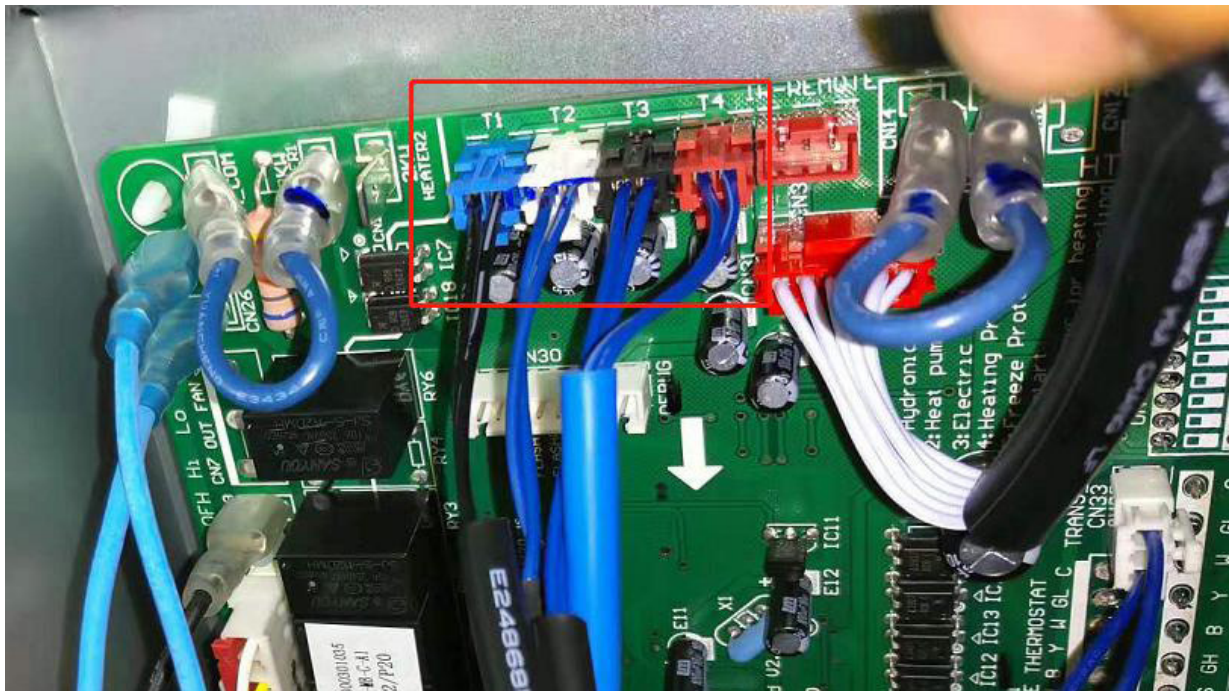

Figure 703

---

# TROUBLESHOOTING

## E4 Function Error

If the E4 error appears during electric heating operation, it could mean that the indoor outlet has overheated.

Check the indoor outlet or inlet for any obstacles that block the air circulation.

Check the indoor motor is functioning properly.

Check air filter and evaporator are not too dirty.

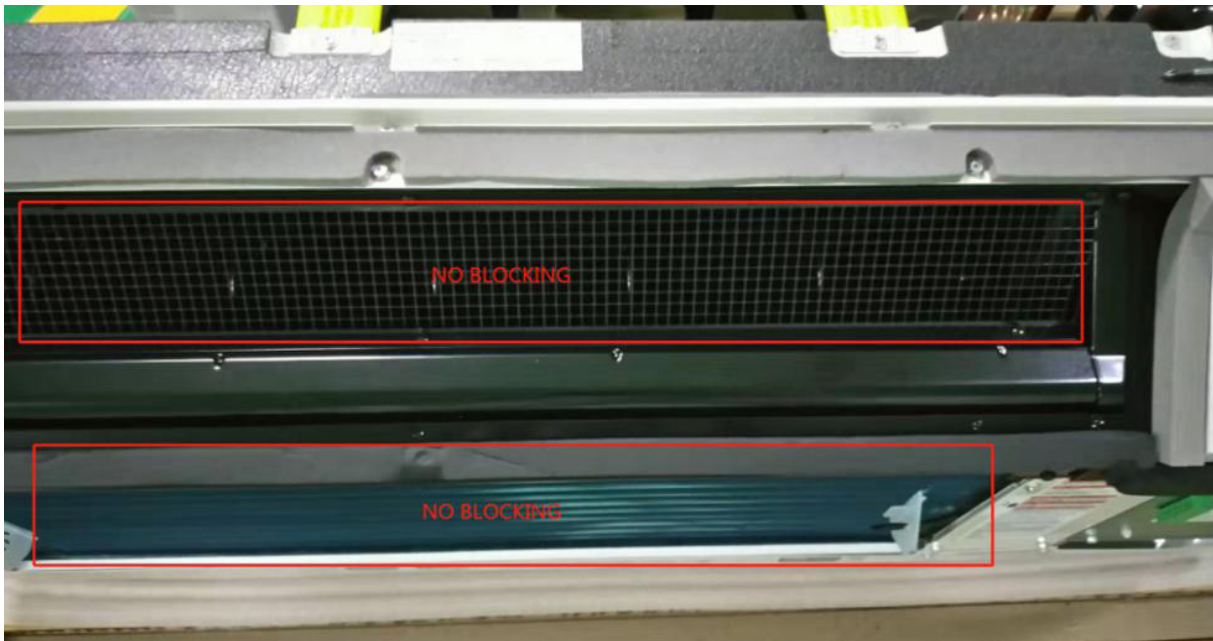

Figure 704



# TROUBLESHOOTING

## E8 Function Error

Indoor fan error. Check the fan capacitor connection.

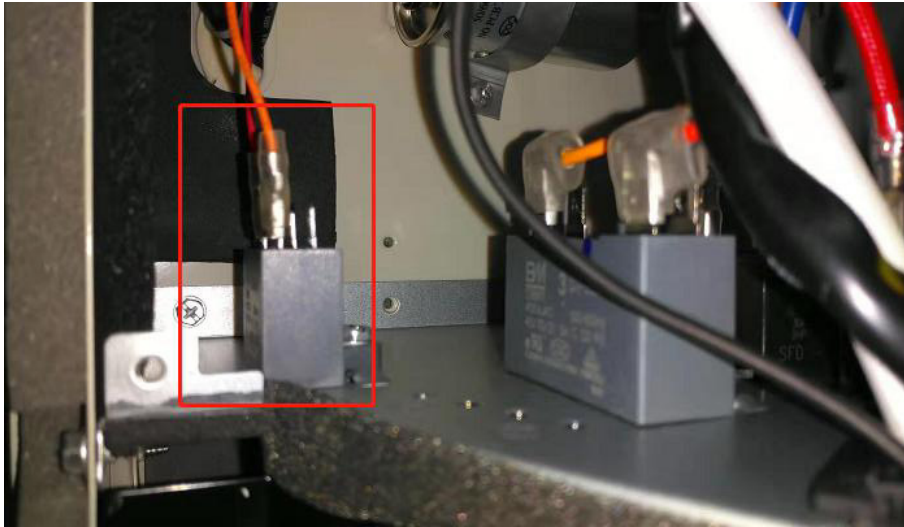

Figure 707

Indoor fan high speed(black wire to N terminal)

Normal resistance is around  $206\Omega$ . If it is over  $1k\Omega$  or less than  $10\Omega$ , that is a broken fan or the fan is under over heat protection

Check to see if resets after cool down.

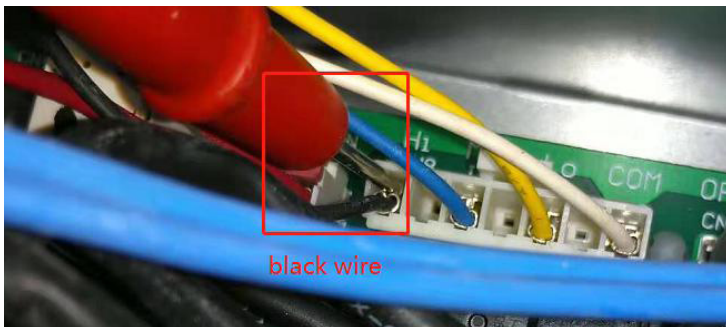

Figure 708

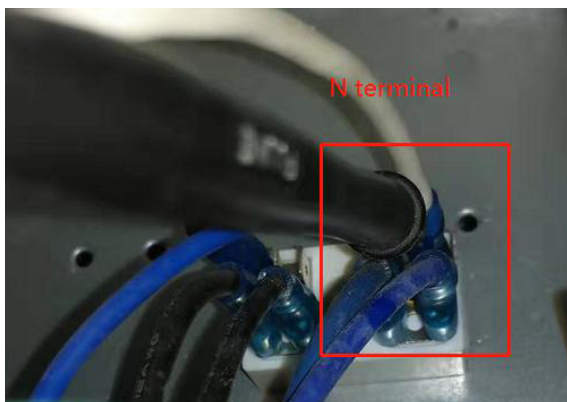

Figure 709



Figure 710

# TROUBLESHOOTING

## E9 Function Error

In COOLING mode, E9 is Refrigerant high pressure protection.

Reasons and solutions:

Outdoor air circulation is bad. Check if any obstacle blocks the air circulation.

Condenser is too dirty. Wash the condenser.



Figure 711

Unit installation error. If the wall sleeve is too wide, the condenser can not exchange air well with the ambient air. Correct the installation. Refer to the Installation/ Operation manual.

Outdoor fan is not running or running speed is too low. Check the fan. The fan blade should be rotated smoothly and the wiring is not loose.



Figure 712

Outdoor Ambient temperature is too high. Increase the set point (this will get more cycles of compressor and let the condenser cool down. This may help avoid E9 error

Condenser coil temperature sensor broken. Replace it.

Jumper on the main board getting loose. Reconnect it. The interface is for a reserved protection(not used so far). If the jumper gets loose, the MCU will think the system is faulted and must be shut down.

# TROUBLESHOOTING

## E9 Function Error

Check the fan capacitor wiring is not getting loose.

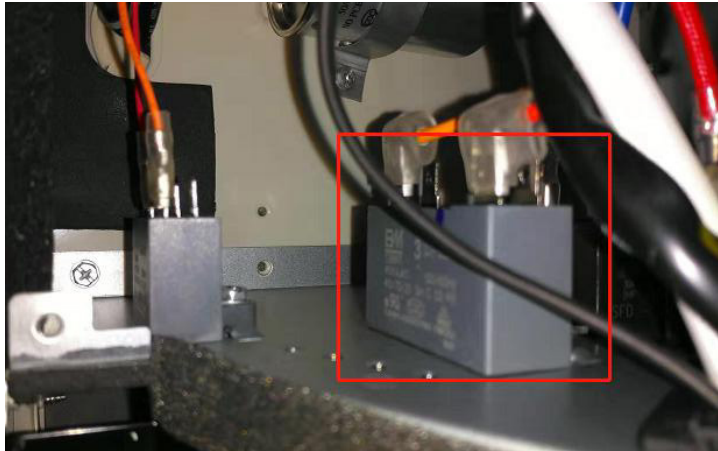

Figure 713

Outdoor fan high speed(black wire to N terminal) normal  
Resistance should be around  $83\Omega$ . If it is over  $1k\ \Omega$  or less that  $10\ \Omega$ , fan is bad or the fan is under over heat protection. It can be cooled down to auto-reset.



Figure 714

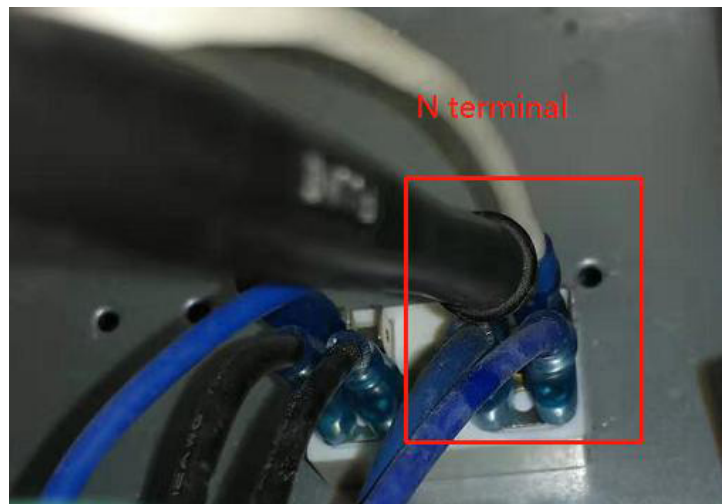

Figure 715

# TROUBLESHOOTING

## E9 Function Error

E9 for condenser coil temperature sensor.

Replace this sensor (black plug marks T3).

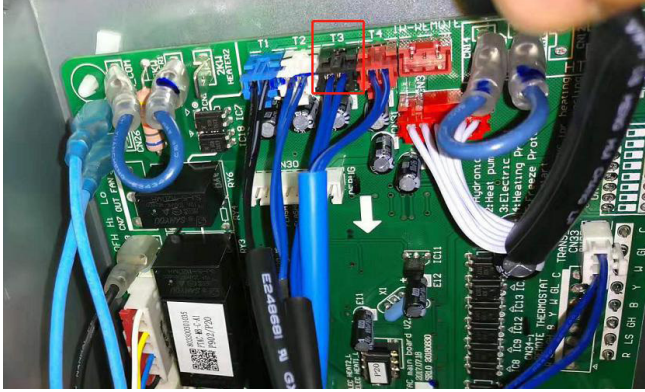

Figure 716

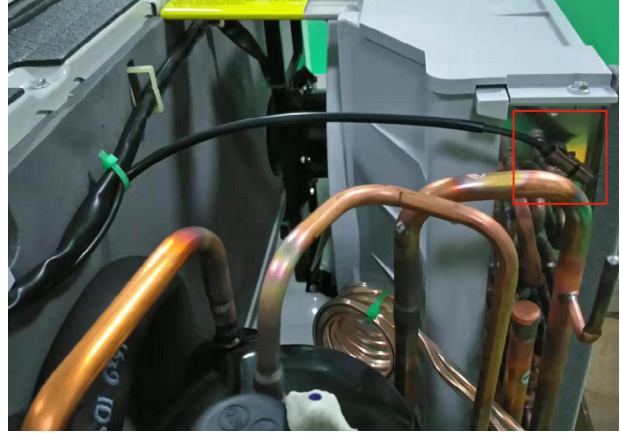

Figure 717

E9 for jumper getting loose.

Reconnect and replace terminal if damaged

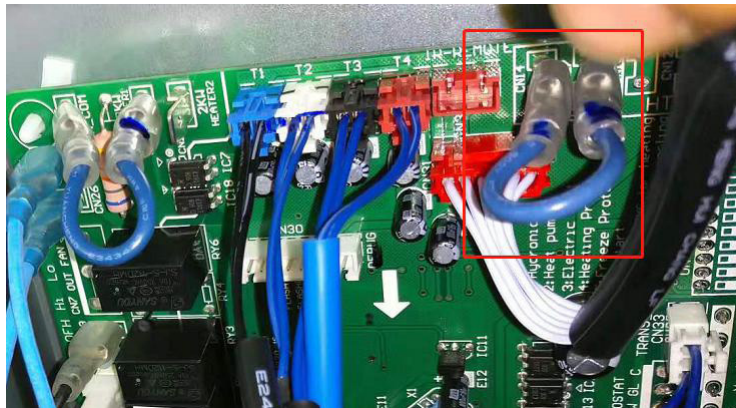

Figure 717

# TROUBLESHOOTING

## Compressor not running

Check the wiring connections.

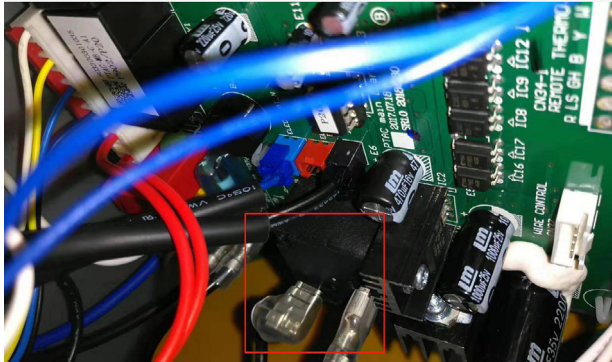

Figure 718



Figure 719

Check the resistance of the compressor.

The normal resistance of compressor main winding (black wire to N terminal) is under  $10\Omega$ .

The resistance range is  $2\Omega - 10\Omega$ .



Figure 720

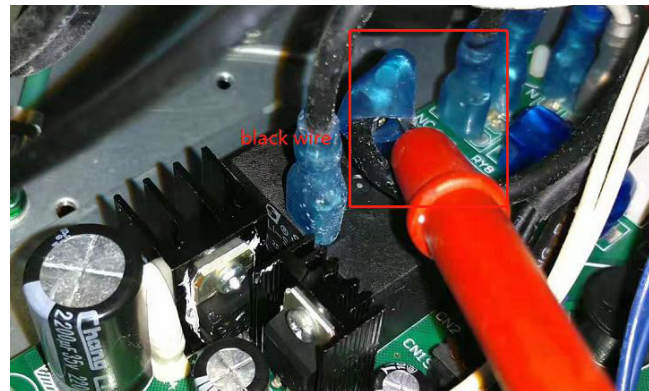

Figure 721

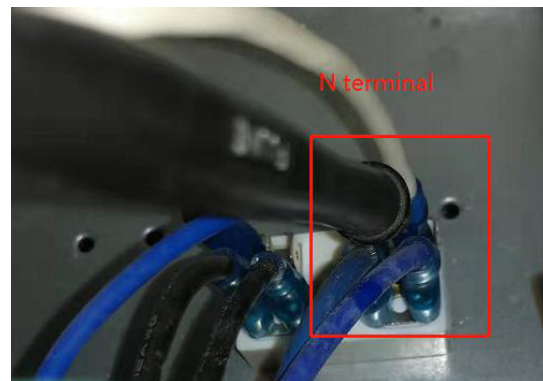

Figure 722

# TROUBLESHOOTING

## Compressor not running

System refrigerant injects too much, this will cause compressor start failure.

Wrong wiring after repairing. Check the wiring with the circuit diagram.

Compressor overloaded. Wait several minutes to restart.

DIP switch setting error. Check it with the circuit diagram

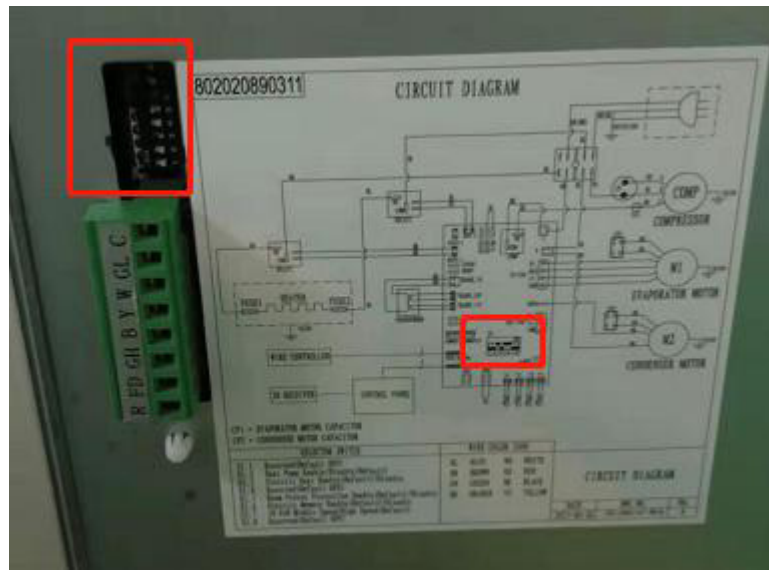

Figure 723

---

# TROUBLESHOOTING

## Electric Heater Not Running

Indoor unit air circulation is blocked. Remove the obstacle.

Thermostat on the heater is cut out. Wait for awhile to see if it can restart.

Thermal fuse is broken. Replace heater.

Wiring error. Check wiring with the circuit diagram.

DIP switch of NO.3 is in OFF position. Set it to ON position.

Wiring error. Check wiring with the circuit diagram.

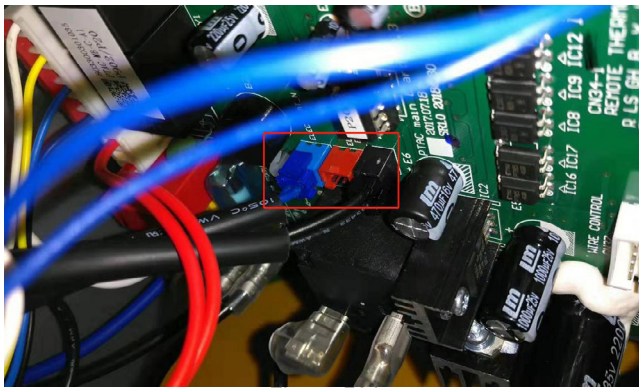

Figure 724

The relay may be faulty. Replace the relay.

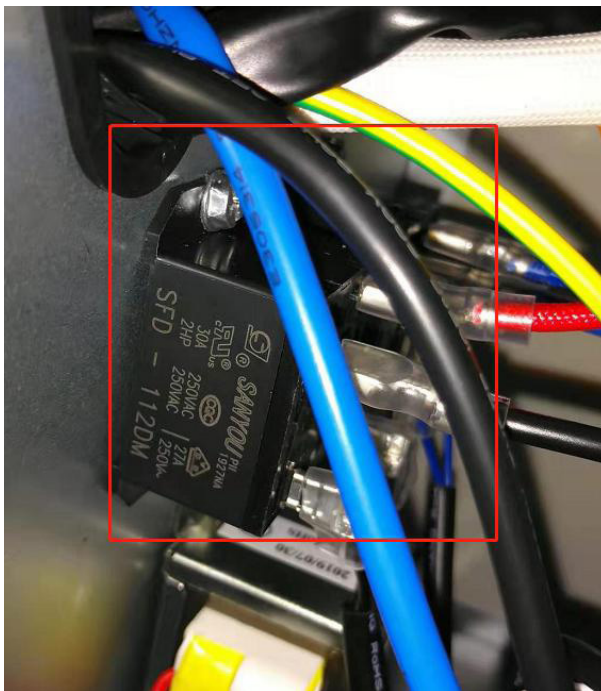

Figure 725

# TROUBLESHOOTING

## Electric Heater Not Running

The normal resistance of the heater can be calculated as  $R=U*U/P$ , U is rated voltage, P is rated power.

For 3.6 kW @230V, the R is  $14.69 \Omega \pm 15\%$ .

For 5 kW @230V, the R is  $10.58\Omega \pm 15\%$ .

For 3.6 kW @265V, the R is  $19.5\Omega \pm 15\%$ .

For 5 kW @265V, the R is  $14\Omega \pm 15\%$ .

Check the red and blue wires connected to the relays,

See where the fingers point to. 3.6kW@230V is measured as  $13.2\Omega$ . The thermostat and thermal fuse are almost  $0\Omega$ , if measured over  $5 \Omega$  that is broken.



Figure 726

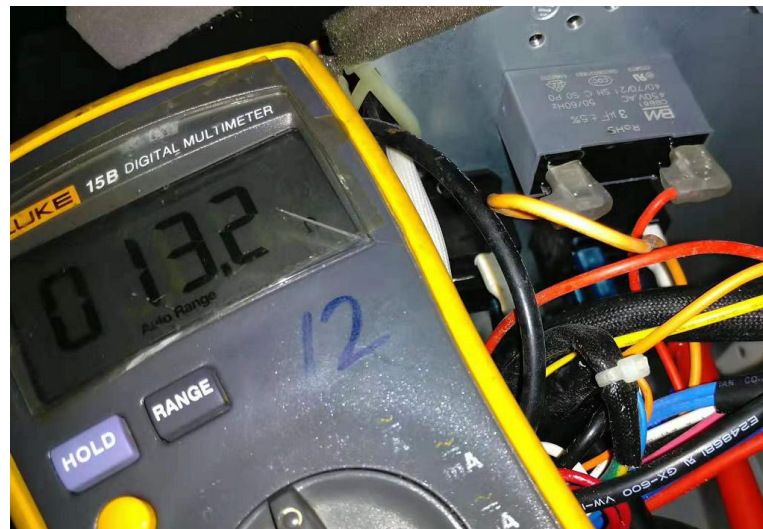

Figure 727

DIP switch of NO.3 is in OFF position. Set it to ON position.

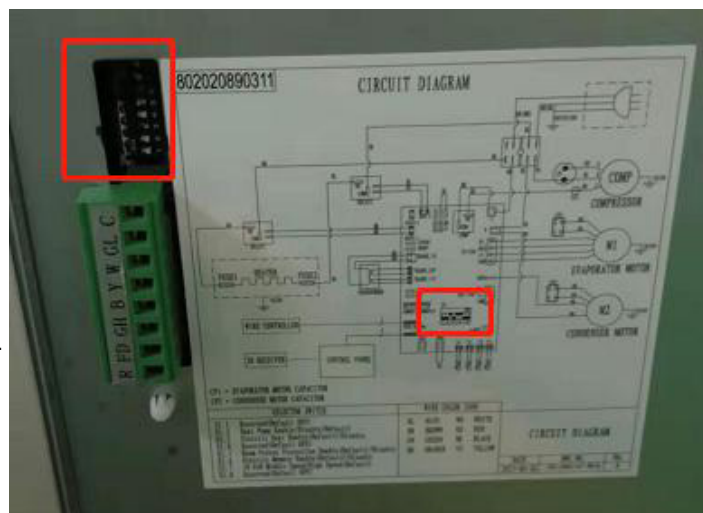

Figure 728

# WIRING DIAGRAMS

7K Cool+ Electric Heat 230 V

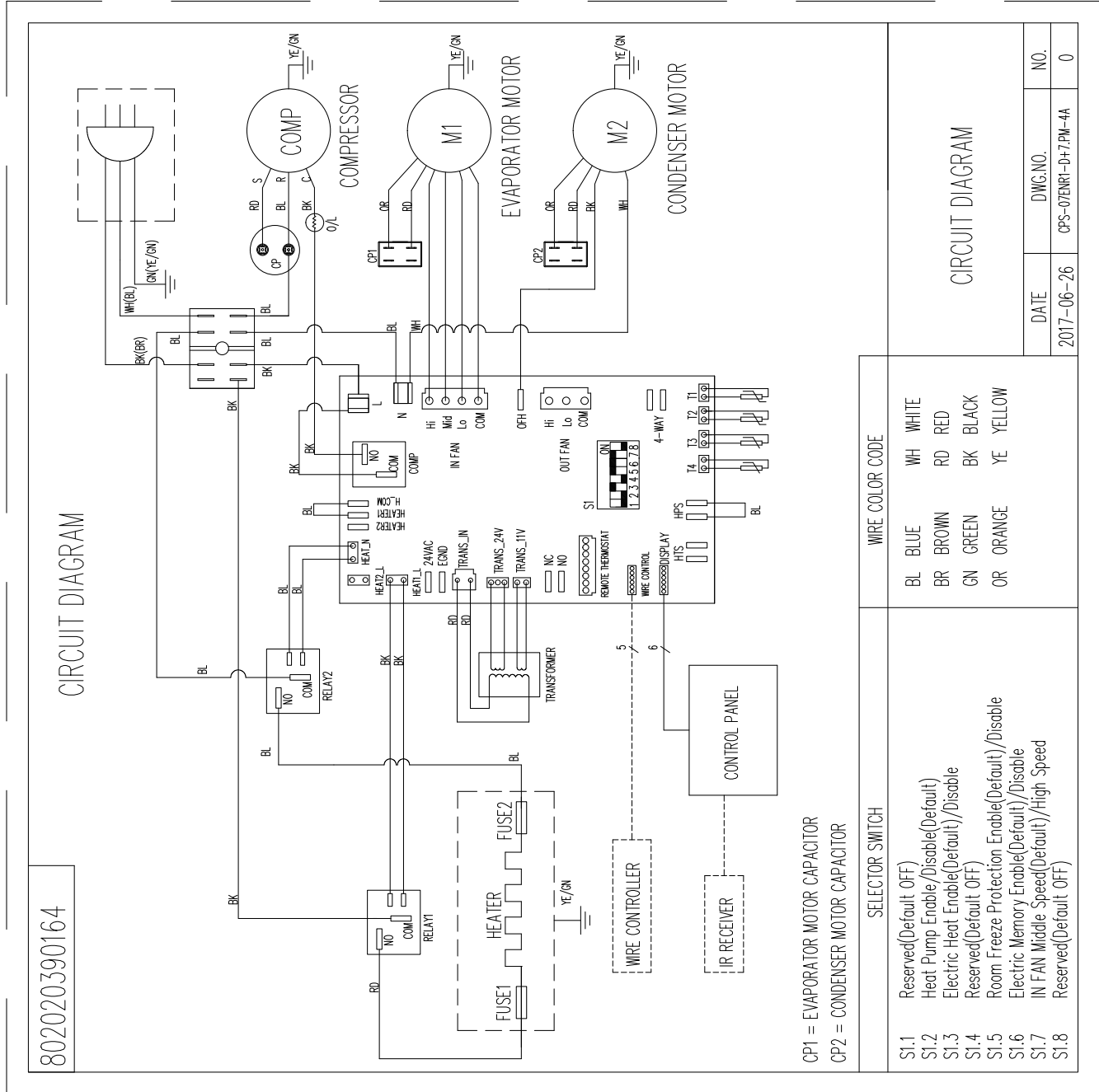

Figure 801

# WIRING DIAGRAMS

9K Cool+ Electric Heat 230v and 265v

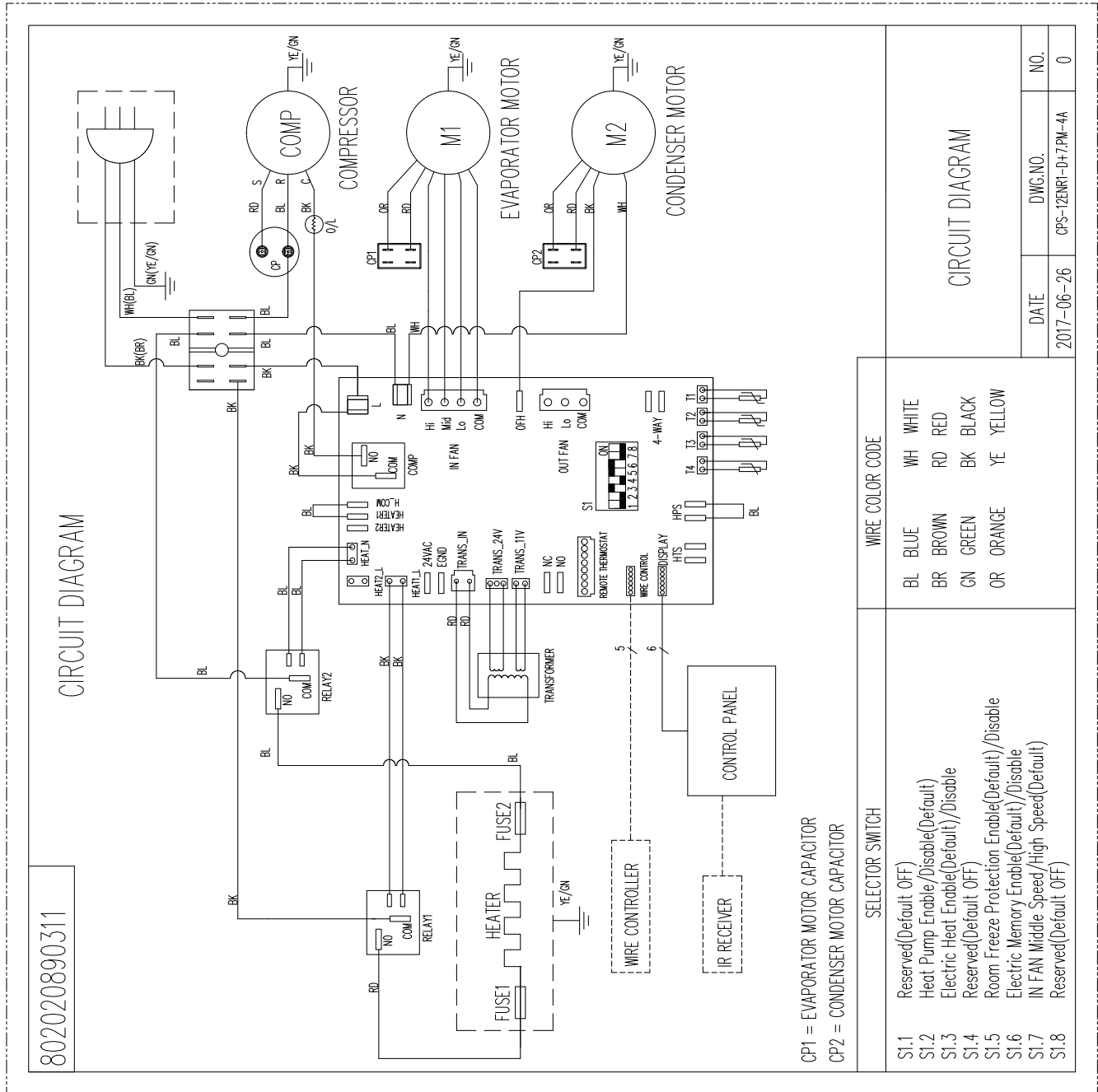

Figure 802

# WIRING DIAGRAMS

12K Cool+ Electric Heat 230v and 265v

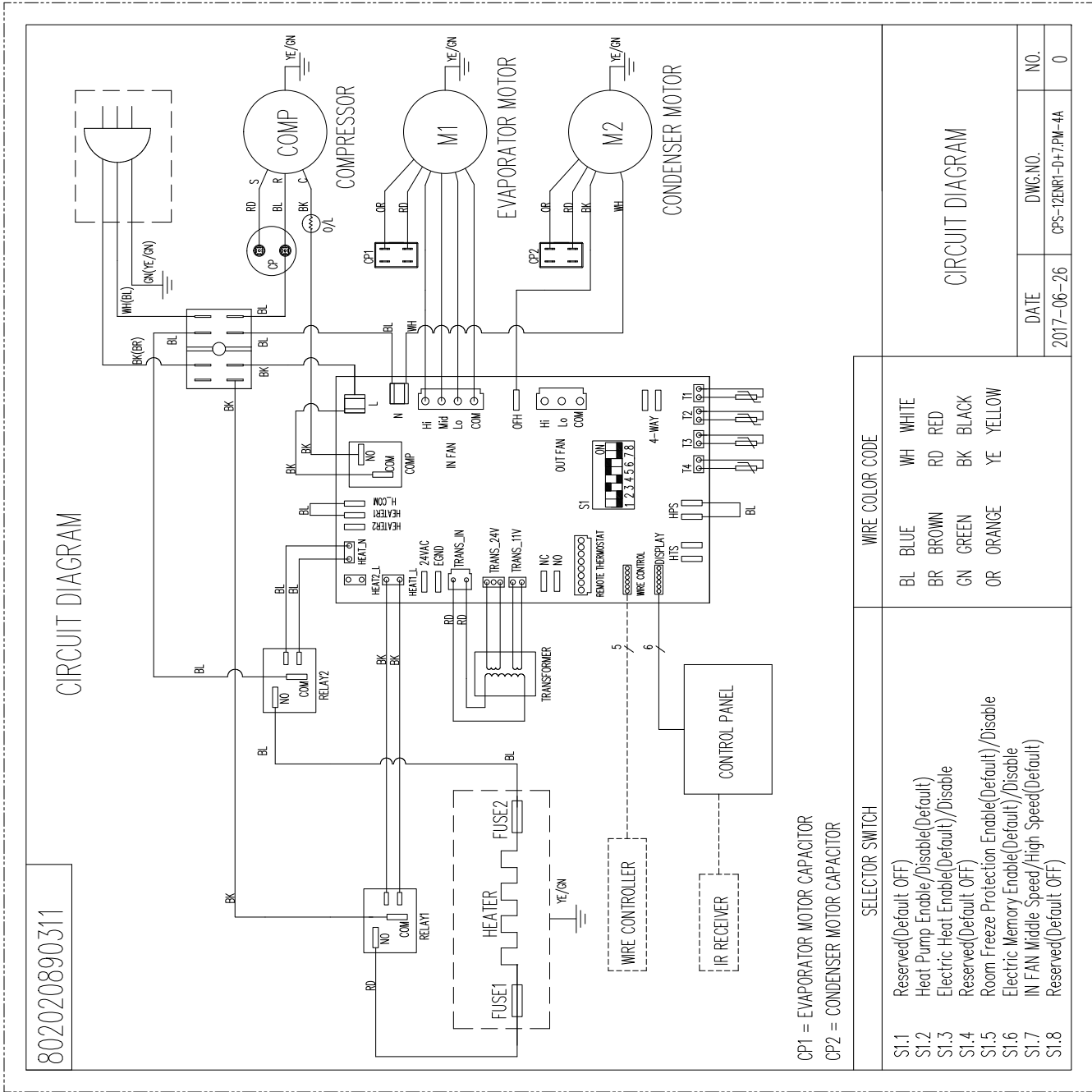

Figure 803

# WIRING DIAGRAMS

15K Cool+ Electric Heat 230v

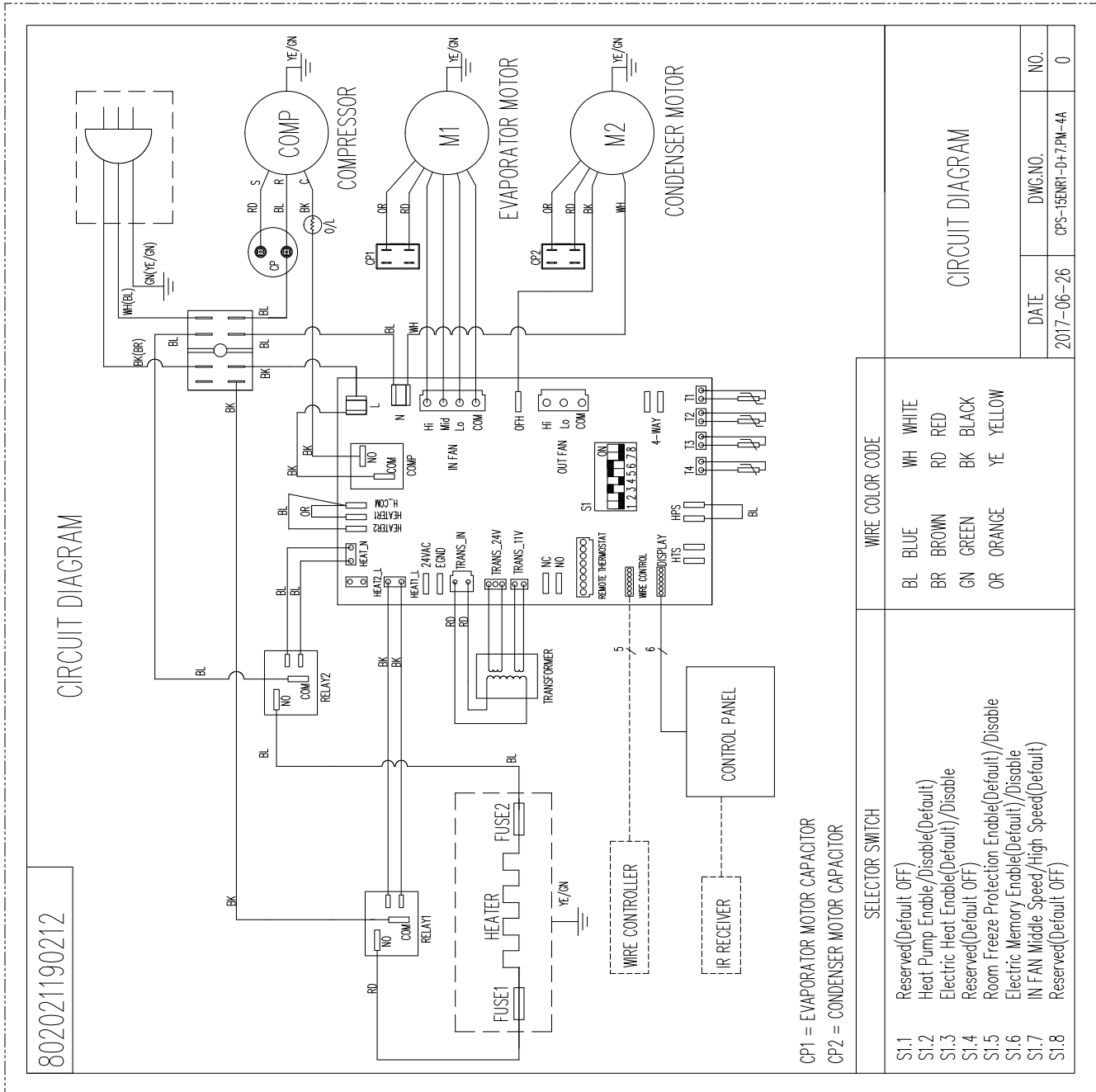

Figure 804

# WIRING DIAGRAMS

7K Cool+ Heat Pump 230v

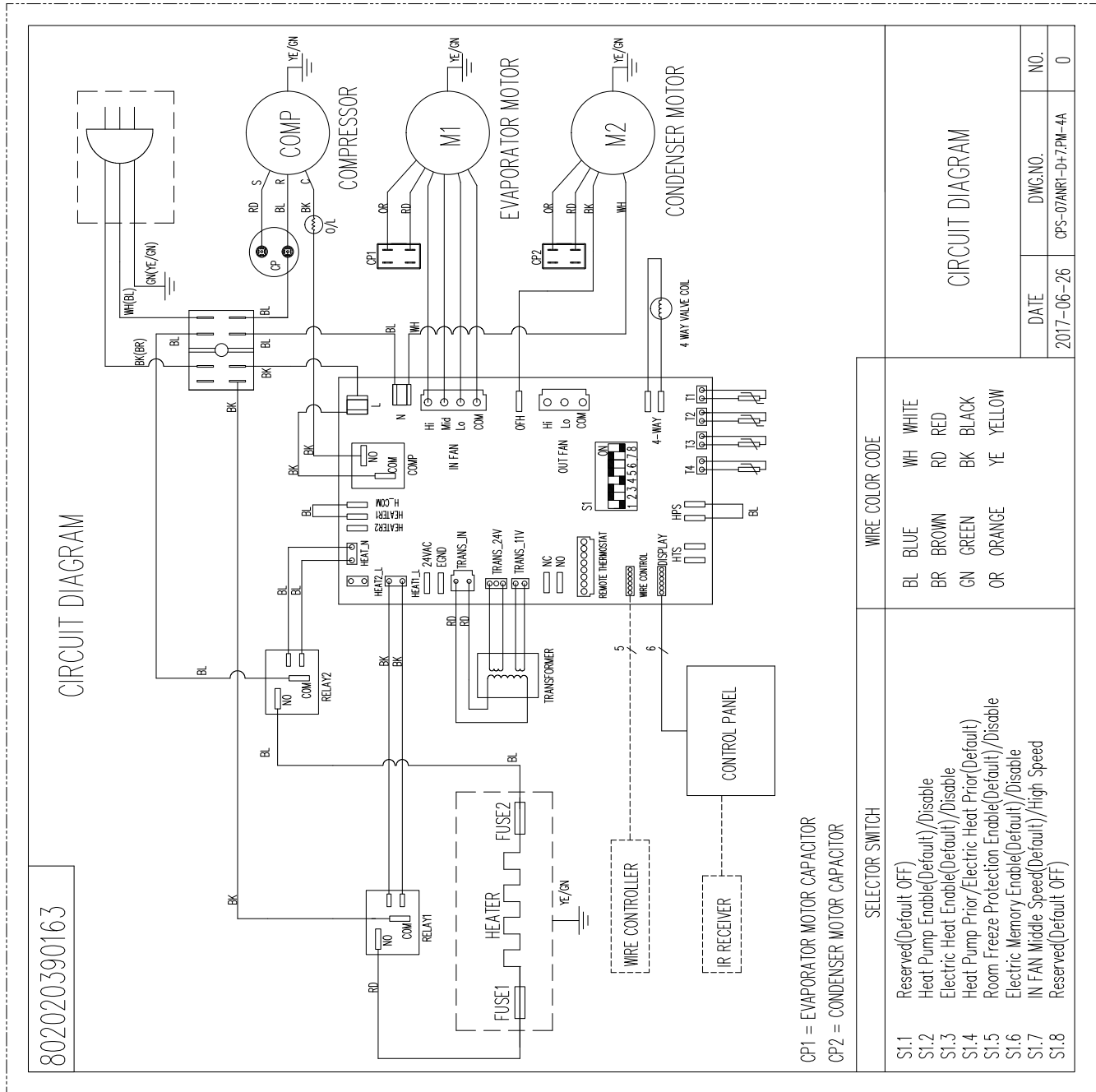

Figure 805

# WIRING DIAGRAMS

9K Cool+ Heat Pump 230v and 265v

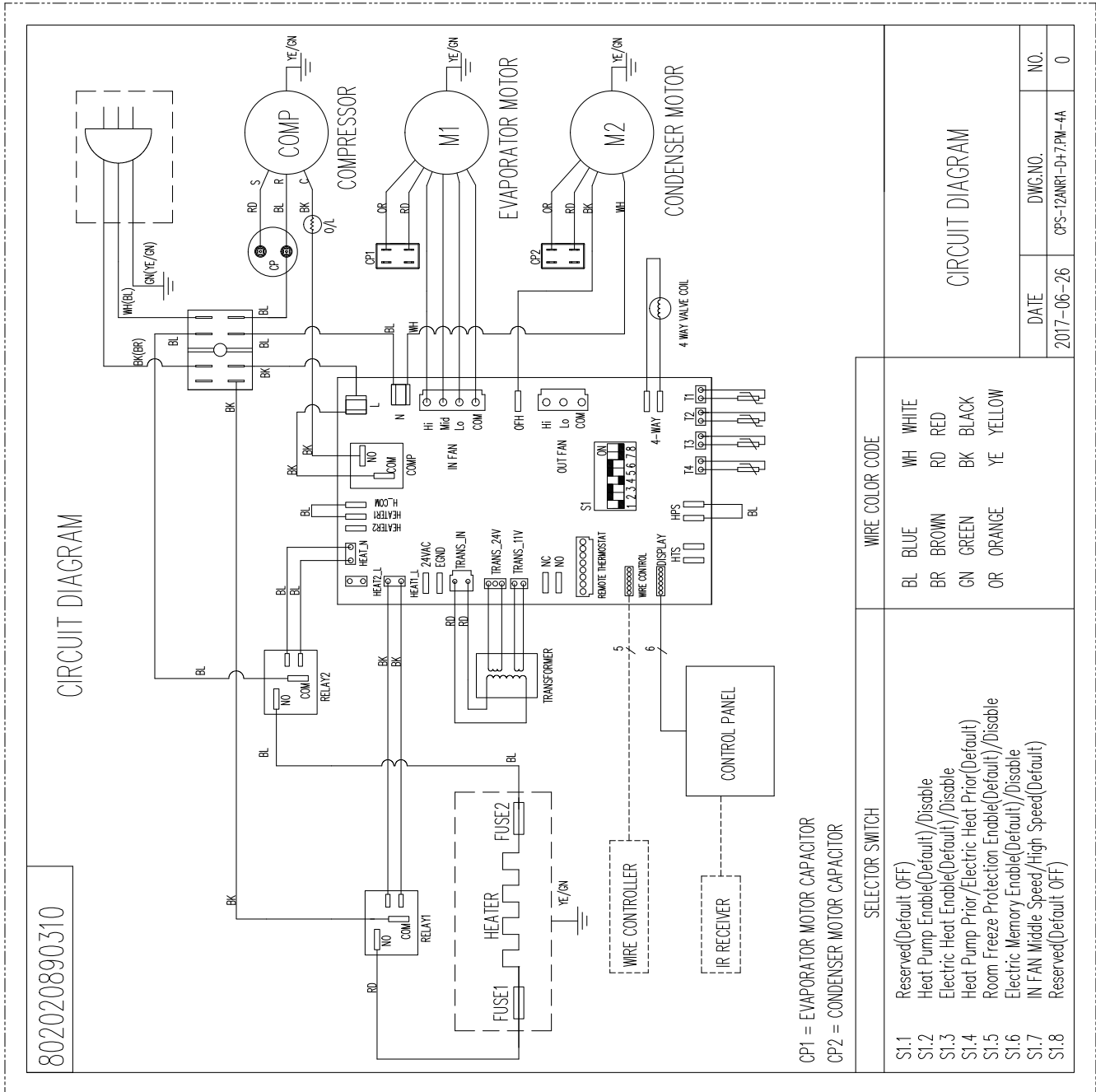

Figure 806



# WIRING DIAGRAMS

15K Cool+ Heat Pump 230v

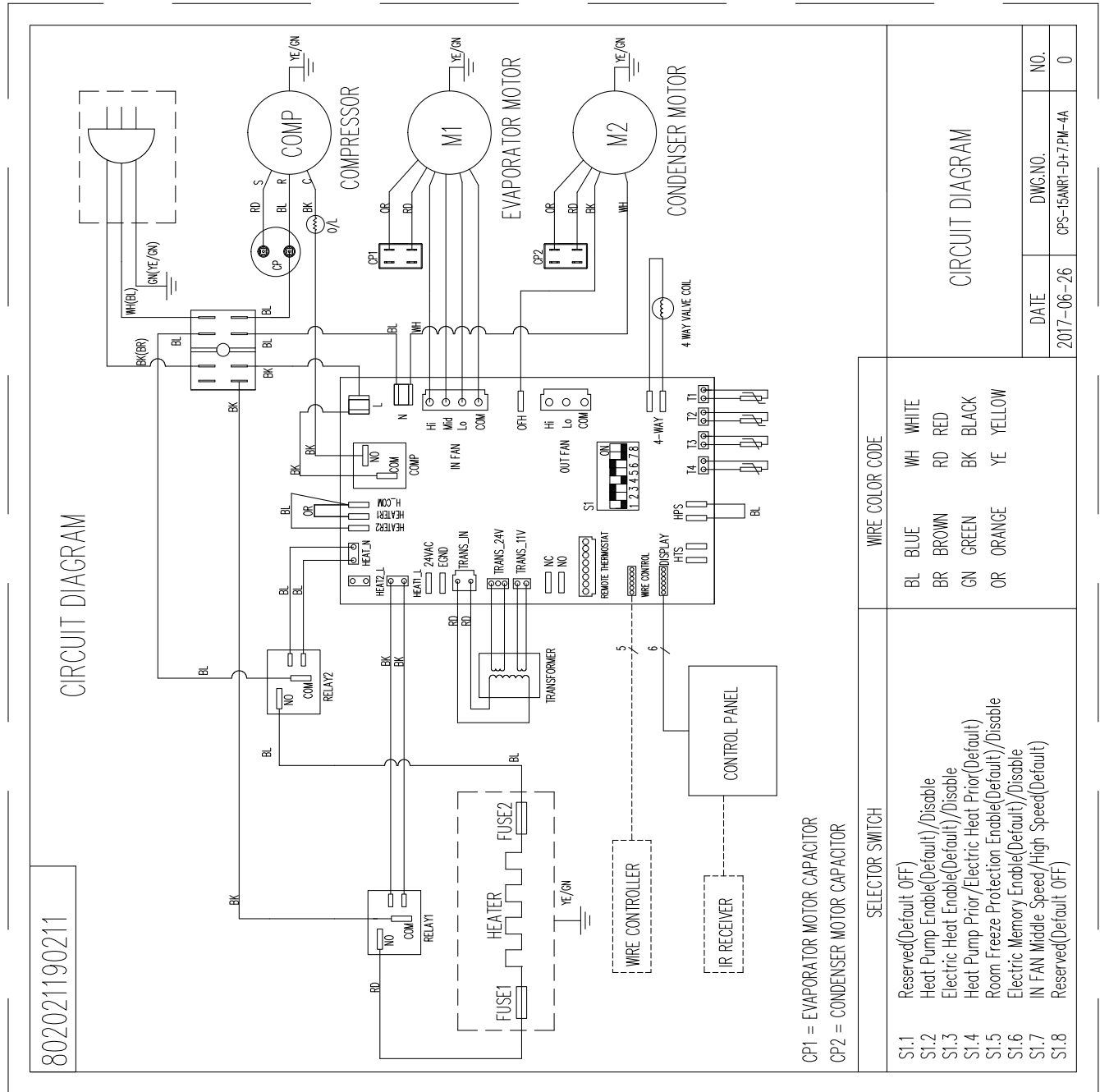

Figure 808

---

# PARTS CATALOG

## Introduction

This illustrated part catalog has been written to help assist the technician to quickly locate the parts that he or she needs to make a repair.

The catalog is broken down into different figures which represent different modules of the air conditioning unit. For example; the chassis, refrigeration system, blower system, or electrical controls. Each figure contains an illustration(s) containing item numbers and a corresponding item list.

The item list contains the item number, part number, part description, the model it is used on, and the quantity used per figure. The models will end with a letter indicating the major revision of the model. for example; WCT12A30A. Choose the part that corresponds with the USED ON MODEL annotation that corresponds to your nameplate.

In some cases there will be an additional "-" letter indicating there has been a minor revision to that model which may have caused a part number change. For example; WCT12A30A-B. If there are minor revisions listed for a part, and the minor revision that is listed on your equipment's nameplate is not listed in the manual please check our online parts viewer for the latest update. If you still require assistance, call Friedrich customer service(1-800-541-6645) for an explanation.

Items with a - in front of the item number (for example -10), are non illustrated items.

Items with an \* in front of the number (for example \*10) are non-stocked items. If you require these items contact Friedrich customer service at (1-800-541-6645) to check for availability and lead time.



# PARTS CATALOG

PZE07K3SB, PZE09K3SB, PZE09R3SB, PZE12K3SB, PZE12R3SB, PZE15K3SB

Figure 901

ITEM	PART NUMBER	PART DESCRIPTION	USED ON MODEL	QTY
1	67808000	FRONT GRILL	ALL	1
2	67808001	PANEL COVER	ALL	1
3	67808002	ELECTRICAL DOOR	ALL	1
4	67808003	INDOOR MOTOR MOUNT	ALL	1
5.1	67808004	INDOOR MOTOR CAPACITOR 450V 1.5UF	PZE07K3SB ,PZE09K3SB, PZE12K3SB, PZE15K3SB	1
5.2	67808005	OUTDOOR MOTOR CAPACITOR 450V 3UF	PZE07K3SB, PZE09K3SB, PZE12K3SB, PZE15K3SB	1
5.2	67808078	OUTDOOR MOTOR CAPACITOR	PZE09R3SB	1
5.2	67808089	OUTDOOR MOTOR CAPACITOR	PZE12R3SB	
5.3	67808006	ELECTRIC HEATER RELAYS	ALL	1
6	67808007	MAIN PCB	ALL	1
7	67808008	ELECTRICAL BOX BOTTOM COVER	ALL	1
8	67808009	TERMINAL BLOCK	ALL	1
9	67808010	ELECTRICAL BOX SIDE COVER	ALL	1
10	67808011	POWER CORD PLATE	ALL	1
11	67808012	PCB STAND OFF	ALL	1
12	67808013	AIR GUIDE PLATE 2	ALL	1
13	67808014	DISPLAY OVERLAY	ALL	1
14	67808015	SEAL BRACKET	ALL	1
15	67808016	24V TRANSFORMER	PZE07K3SB, PZE09K3SB, PZE12K3SB, PZE15K3SB	1
15	67812179	24V TRANSFORMER	PZE09R3SB, PZE12R3SB	
16	67812092	POWER CORD FASTENER	PZE07K3SB, PZE09K3SB, PZE12K3SB, PZE12R3SB	1
16	67808063	POWER CORD FASTENER	PZE09R3SB	1
16	67808017	POWER CORD FASTENER	PZE15K3SB	1
17	67808065	COMPRESSOR	PZE07K3SB	1
17	67808074	COMPRESSOR	PZE09K3SB	1
17	67808080	COMPRESSOR	PZE09R3SB	1
17	67812104	COMPRESSOR	PZE12K3SB	1
17	67808090	COMPRESSOR	PZE12R3SB	1
17	67808018	COMPRESSOR	PZE15K3SB	1
18	67808019	CAPACITOR BRACKET	ALL	1
19	67808072	COMPRESSOR CAPACITOR	PZE07K3SB	1
19	67808075	COMPRESSOR CAPACITOR 450V 20UF	PZE09K3SB, PZH09K3SB	1
19	67808081	COMPRESSOR CAPACITOR	PZE09R3SB	1
19	67808020	COMPRESSOR CAPACITOR	PZE12K3SB, PZE15K3SB	1
19	67808091	COMPRESSOR CAPACITOR	PZE12R3SB	1
20	67808021	CABLE CAP	ALL	1

# PARTS CATALOG

PZE07K3SB, PZE09K3SB, PZE09R3SB, PZE12K3SB, PZE12R3SB, PZE15K3SB

Figure 901

ITEM	PART NUMBER	PART DESCRIPTION	USED ON MODEL	QTY
21	67808071	OUTDOOR MOTOR	PZE07K3SB, PZE09K3SB, PZE12K3SB	1
21	67808082	OUTDOOR MOTOR	PZE09R3SB	1
21	67808092	OUTDOOR MOTOR	PZE12R3SB	1
21	67808022	OUTDOOR MOTOR	PZE15K3SB	1
22	67808023	OUTDOOR FAN BLADE	ALL	1
23	67808024	OUTDOOR LOUVER	ALL	1
24	67808025	TOP AIR GUIDE	ALL	1
25	67808026	INDOOR FAN GUARD	ALL	1
26	67808027	EVAPORATOR COIL	ALL	1
27	67808028	INDOOR BLOWER HOUSING	ALL	1
28	67808029	BASE PAN	ALL	1
29	67808030	TOP SUPPORT BRACKET	ALL	1
30	67812168	CLAPBOARD	ALL	1
31	67808032	FAN SHROUD	ALL	1
32	67808066	CONDENSER COIL	PZE07K3SB	1
32	67808033	CONDENSER COIL	PZE09K3SB, PZE12K3SB, PZE09R3SB, PZE12R3SB, PZE-15K3SB	1
33	67808034	BLOWER END PLATE	ALL	1
34	67808035	BLOWER BEARING	ALL	1
35	67808036	FAN WHEEL RIGHT CLIP	ALL	1
36	67808037	FAN WHEEL LEFT CLIP	ALL	1
37	67808038	BLOWER WHEEL BEARING	ALL	1
38	67808039	BLOWER END PLATE	ALL	1
39	67808040	SENSOR HOLDER	ALL	1
40	67808070	INDOOR MOTOR	PZE07K3SB , PZE09K3SB	1
40	67808083	INDOOR MOTOR	PZE09R3SB	1
40	67812105	INDOOR MOTOR	PZE12K3SB	1
40	67808093	INDOOR MOTOR	PZE12R3SB	1
40	67808041	INDOOR MOTOR	PZE15K3SB	1
41	67808042	BLOWER WHEEL	ALL	1
42	67808043	DISCHARGE LOUVER	ALL	1
43	67808044	AIR FILTER	ALL	1
44	67808045	FRESH AIR FILTER	ALL	1
45	67808067	CONDENSER HEADER ASSY	PZE07K3SB	1
45	67808076	CONDENSER HEADER ASSY	PZE09K3SB	1
45	67808094	CONDENSER HEADER ASSY	PZE09R3SB, PZE12R3SB	1
45	67812106	CONDENSER HEADER ASSY	PZE12K3SB	1
45	67812111	CONDENSER HEADER ASSY	PZE15K3SB	1
46	67808069	EVAPORATOR DISTRIBUTOR ASSY	PZE07K3SB	1

# PARTS CATALOG

PZE07K3SB, PZE09K3SB, PZE09R3SB, PZE12K3SB, PZE12R3SB, PZE15K3SB

Figure 901

ITEM	PART NUMBER	PART DESCRIPTION	USED ON MODEL	QTY
46	67808077	EVAPORATOR DISTRIBUTOR ASSY	PZE09K3SB	1
46	67808095	EVAPORATOR DISTRIBUTOR ASSY	PZE09R3SB, PZE12R3SB	1
46	67812107	EVAPORATOR DISTRIBUTOR ASSY	PZE12K3SB	1
46	67812112	EVAPORATOR DISTRIBUTOR ASSY	PZE15K3SB	1
47	67808048	LEFT PANEL	ALL	1
48.1	67808049	FRESH AIR FILTER GUIDE	ALL	1
48.2	67808050	FRESH AIR FILTER LEVER	ALL	1
49	67812176	SUPPORT BRACKETS	PZE09K3SB, PZE12K3SB	1
49	67812169	SUPPORT BRACKETS	PZE07K3SB, PZE09R3SB, PZE12R3SB, PZE15K3SB	1
50.1	67808051	FRESH AIR WIRE	ALL	1
50.2	67808053	FRESH AIR DOOR BUSHING	ALL	1
51	67808054	OUTDOOR MOTOR BRACKET	ALL	1
52	67808055	FAN SHROUD TOP	ALL	1
53	67808064	SEAL PLATE	ALL	1
54	67808056	RIGHT CORNER POST	ALL	1
55	67808057	LEFT CORNER POST	ALL	1
56	67808058	BEARING SEAL PLATE	ALL	1
57	67808059	INDOOR FOAM PAN	ALL	1
58	67808060	FRESH AIR DOOR CABLE HOLDER	ALL	1
59	67808061	FRESH AIR DOOR	ALL	1
60	67808073	ELECTRIC HEAT ELEMENT	PZE07K3SB, PZE09K3SB, PZE12K3SB	1
60	67808086	ELECTRIC HEAT ELEMENT	PZE09R3SB, PZE12R3SB	1
60	67808062	ELECTRIC HEAT ELEMENT	PZE15K3SB	1
61	67808068	CONDENSER CAPILARY ASSY	PZE07K3SB	1
61	67812177	CONDENSER CAPILARY ASSY	PZE09K3SB	1
61	67808098	CONDENSER CAPILARY ASSY	PZE09R3SB	1
61	67812108	CONDENSER CAPILARY ASSY	PZE12K3SB	1
61	67808096	CONDENSER CAPILARY ASSY	PZE12R3SB	1
61	67812113	CONDENSER CAPILARY ASSY	PZE15K3SB	1
-63	67812089	SADDLE CLIP	ALL	1
-64	67812171	COMPRESSOR HARNESS	ALL	1
65	67812091	DISPLAY PCB	ALL	1
--66	67808063	POWER CORD FASTENER	PZE07K3SB, PZE09K3SB, PZE09R3SB, PZE12K3SB, PZE12R3SB	1
-66	67812114	POWER CORD FASTENER	PZE15K3SB	1
-67	67812093	DISPLAY ESCUTCHEON	ALL	1
-68	67812094	ROOM TEMP SENSOR	ALL	1

# PARTS CATALOG

PZE07K3SB, PZE09K3SB, PZE09R3SB, PZE12K3SB, PZE12R3SB, PZE15K3SB

Figure 901

ITEM	PART NUMBER	PART DESCRIPTION	USED ON MODEL	QTY
-69	67812095	INDOOR COIL SENSOR	ALL	1
-70	67812096	OUTDOOR COIL SENSOR	ALL	1
-71	67812097	DISCHARGE AIR SENSOR	ALL	1
-72	67812098	POWER CORD LCDI	ALL	1
-73	67812172	PANEL CLIP	ALL	1
-74	67812100	BELLOWS VALVE	ALL	1

-ITEMS ARE NON- ILLUSTRATED  
\*ITEMS ARE NON-STOCKED, WILL NORMALLY REQUIRE 2-3 WEEKS LEAD TIME

# PARTS CATALOG

PZH07K3SB, PZH09K3SB, PZH09R3SB, PZH12K3SB, PZH12R3SB, PZH15K3SB

Figure 902

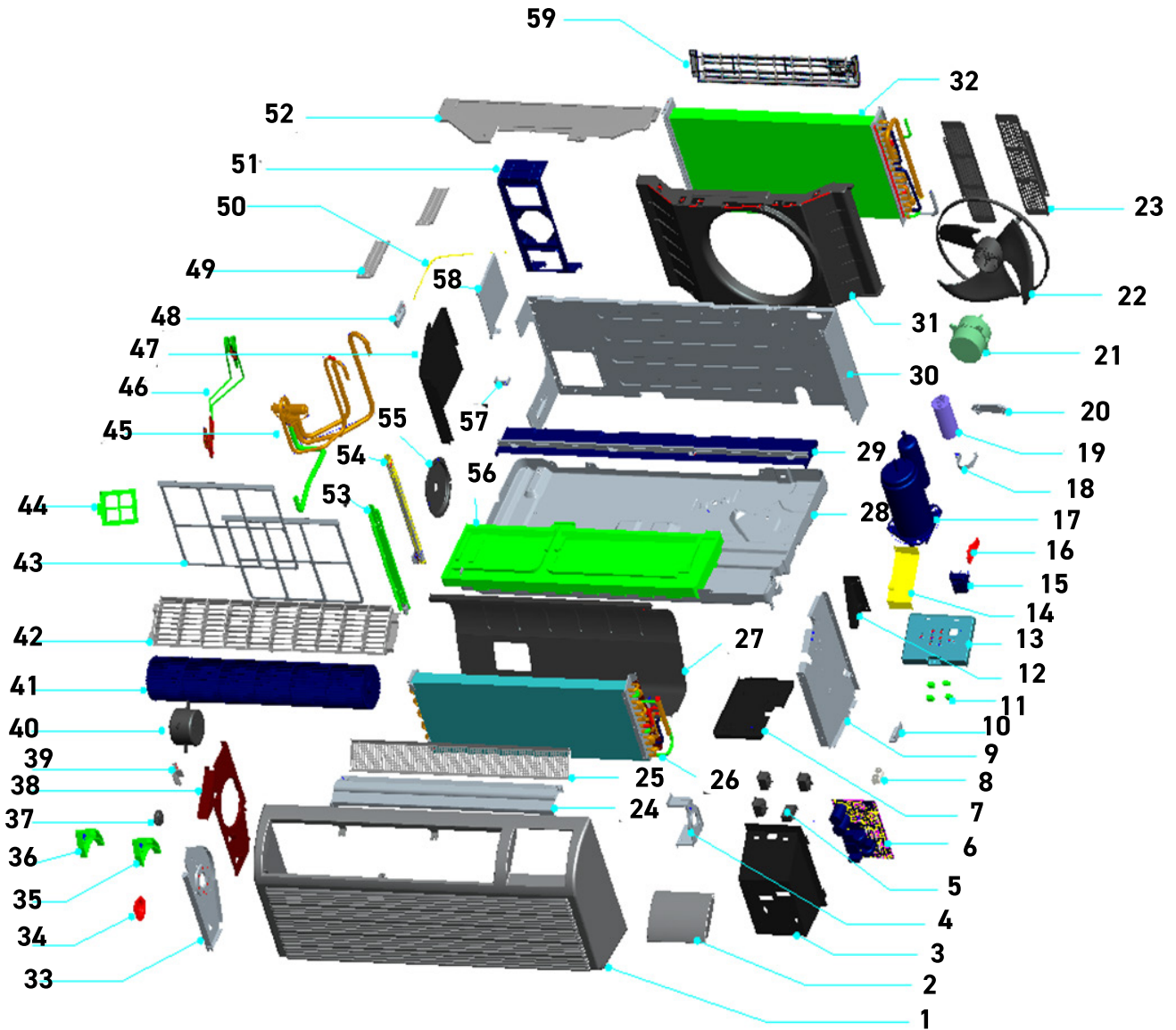

# PARTS CATALOG

PZH07K3SB, PZH09K3SB, PZH09R3SB, PZH12K3SB, PZH12R3SB, PZH15K3SB Figure 902

ITEM	PART NUMBER	PART DESCRIPTION	USED ON MODEL	QTY
1	67808000	FRONT GRILL	ALL	1
2	67808001	PANEL COVER	ALL	1
3	67808002	ELECTRICAL DOOR	ALL	1
4	67808003	INDOOR MOTOR MOUNT	ALL	1
5.1	67808004	INDOOR MOTOR CAPACITOR 450V 1.5UF	PZH07K3SB, PZH09K3SB, PZH12K3SB, PZH15K3SB	1
5.2	67808005	OUTDOOR MOTOR CAPACITOR 450V 3UF	PZH07K3SB, , PZH09K3SB, PZH12K3SB, PZH15K3SB	1
5.2	67808078	OUTDOOR MOTOR CAPACITOR	PZH09R3SB	1
5.2	67808089	OUTDOOR MOTOR CAPACITOR	PZH12R3SB	1
5.3	67808006	ELECTRIC HEATER RELAYS	ALL	1
6	67808007	MAIN PCB	ALL	1
7	67808008	ELECTRICAL BOX BOTTOM COVER	ALL	1
8	67808009	TERMINAL BLOCK	ALL	1
9	67808010	ELECTRICAL BOX SIDE COVER	ALL	1
10	67808011	POWER CORD PLATE	ALL	1
11	67808012	PCB STAND OFF	ALL	1
12	67808013	AIR GUIDE PLATE 2	ALL	1
13	67808014	DISPLAY OVERLAY	ALL	1
14	67808015	SEAL BRACKET	ALL	1
15	67808016	24V TRANSFORMER	PZH07K3SB, PZH09K3SB, PZH12K3SB, PZH15K3SB	1
15	67812179	24V TRANSFORMER	PZH09R3SB, PZH12R3SB	1
16	67812092	POWER CORD FASTENER	PZH07K3SB, PZH12K3SB, PZH12R3SB	1
16	67808063	POWER CORD FASTENER	PZH09K3SB	1
16	67808017	POWER CORD FASTENER	PZH15K3SB	1
17	67808065	COMPRESSOR	PZH07K3SB	1
17	67808074	COMPRESSOR	PZH09K3SB	1
17	67808080	COMPRESSOR	PZH09R3SB	1
17	67808090	COMPRESSOR	PZH12R3SB	1
17	67808018	COMPRESSOR	PZH15K3SB	
18	67808019	CAPACITOR BRACKET	ALL	1
19	67808072	COMPRESSOR CAPACITOR	PZH07K3SB	1
19	67808075	COMPRESSOR CAPACITOR 450V 20UF	PZH09K3SB	1
19	67808081	COMPRESSOR CAPACITOR	PZH09R3SB	1
19	67808020	COMPRESSOR CAPACITOR	PZH12R3SB, PZH15K3SB	1
19	67808091	COMPRESSOR CAPACITOR	PZH12R3SB	1
20	67808021	CABLE CAP	ALL	1
21	67808071	OUTDOOR MOTOR	PZH07K3SB, PZH09K3SB, PZH12K3SB	1

# PARTS CATALOG

PZH07K3SB, PZH09K3SB, PZH09R3SB, PZH12K3SB, PZH12R3SB, PZH15K3SB Figure 902









ITEM	PART NUMBER	PART DESCRIPTION	USED ON MODEL	QTY
21	67808082	OUTDOOR MOTOR	PZH09R3SB	1
21	67808092	OUTDOOR MOTOR	PZH12R3SB	1
21	67808022	OUTDOOR MOTOR	PZH15K3SB	1
22	67808023	OUTDOOR FAN BLADE	ALL	1
23	67808024	OUTDOOR LOUVER	ALL	1
24	67808025	TOP AIR GUIDE	ALL	1
25	67808026	INDOOR FAN GUARD	ALL	1
26	67808027	EVAPORATOR COIL	ALL	1
27	67808028	INDOOR BLOWER HOUSING	ALL	1
28	67808029	BASE PAN	ALL	1
29	67808030	TOP SUPPORT BRACKET	ALL	1
30	67812168	CLAPBOARD	ALL	1
31	67808032	FAN SHROUD	ALL	1
32	67808033	CONDENSER COIL	ALL	1
33	67808034	BLOWER END PLATE	ALL	1
34	67808035	BLOWER BEARING	ALL	1
35	67808036	FAN WHEEL RIGHT CLIP	ALL	1
36	67808037	FAN WHEEL LEFT CLIP	ALL	1
37	67808038	BLOWER WHEEL BEARING	ALL	1
38	67808039	BLOWER END PLATE	ALL	1
39	67808040	SENSOR HOLDER	ALL	1
40	67808070	INDOOR MOTOR	PZH07K3SB, PZH09K3SB	1
40	67808083	INDOOR MOTOR	PZH09R3SB	1
40	67808093	INDOOR MOTOR	PZH12R3SB	1
40	67808041	INDOOR MOTOR	PZH15K3SB	1
41	67808042	BLOWER WHEEL	ALL	1
42	67808043	DISCHARGE LOUVER	ALL	1
43	67808044	AIR FILTER	ALL	1
44	67808045	FRESH AIR FILTER	ALL	1
45	67812087	REVERSING VALVE ASSEMBLY	PZH07K3SB	1
45	67812102	REVERSING VALVE ASSEMBLY	PZH09K3SB	1
45	67808084	REVERSING VALVE ASSEMBLY	PZH09R3SB, PZH12R3SB	1
45	67812181	REVERSING VALVE ASSEMBLY	PZH12R3SB	1
45	67808046	REVERSING VALVE ASSEMBLY	PZH15K3SB	1
46	67812088	CHECK VALVE	PZH07K3SB	1
46	67812103	CHECK VALVE	PZH09K3SB	1
46	67808085	CHECK VALVE	PZH09R3SB	1
46	67812110	CHECK VALVE	PZH12R3SB	1
46	67808097	CHECK VALVE	PZH12R3SB	1

# PARTS CATALOG



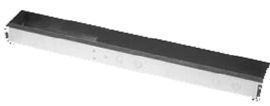



PZH07K3SB, PZH09K3SB, PZH09R3SB, PZH12K3SB, PZH12R3SB, PZH15K3SB Figure 902

ITEM	PART NUMBER	PART DESCRIPTION	USED ON MODEL	QTY
46	67808047	CHECK VALVE	PZH15K3SB	1
47	67808048	LEFT PANEL	ALL	1
48.1	67808049	FRESH AIR FILTER GUIDE	ALL	1
48.2	67808050	FRESH AIR FILTER LEVER	ALL	1
49	67812176	SUPPORT BRACKETS	PZH12K3SB, PZH15K3SB	1
49	67812169	SUPPORT BRACKETS	PZH07K3SB, PZH09K3SB, PZH09R3SB, PZH12R3SB	1
50.1	67808051	FRESH AIR WIRE	ALL	1
50.2	67808053	FRESH AIR DOOR BUSHING	ALL	1
51	67808054	OUTDOOR MOTOR BRACKET	ALL	1
52	67808055	FAN SHROUD TOP	ALL	1
53	67808056	RIGHT CORNER POST	ALL	1
54	67808057	LEFT CORNER POST	ALL	1
55	67808058	BEARING SEAL PLATE	ALL	1
56	67808059	INDOOR FOAM PAN	ALL	1
57	67808060	FRESH AR DOOR CABLE HOLDER	ALL	1
58	67808061	FRESH AIR DOOR	ALL	1
59	67808073	ELECTRIC HEAT ELEMENT	PZH07K3SB	1
59	67808073	ELECTRIC HEAT ELEMENT	PZH09K3SB, PZH12K3SB	1
59	67808086	ELECTRIC HEAT ELEMENT	PZH09R3SB, PZH12R3SB	1
59	67808062	ELECTRIC HEAT ELEMENT	PZH15K3SB	1
-61	67812089	SADDLE CLIP	ALL	1
-62	67812171	COMPRESSOR HARNESS	ALL	1
-63	67812091	DISPLAY PCB	ALL	1
-64	67808063	POWER CORD FASTENER	PZH07K3SB, PZH09K3SB, PZH09R3SB, PZH12K3SB	1
-64	67812114	POWER CORD FASTENER	PZH15K3SB	1
-65	67812093	DISPLAY ESCUTCHEON	ALL	1
-66	67812094	ROOM TEMP SENSOR	ALL	1
-67	67812095	INDOOR COIL SENSOR	ALL	1
-68	67812096	OUTDOOR COIL SENSOR	ALL	1
69	67812097	DISCHARGE AIR SENSOR	ALL	1
-70	67812098	POWER CORD LCDI	ALL	1
-71	67808064	SEAL PLATE	ALL	1
-72	67812172	PANEL CLIP	ALL	1
-73	67812100	BELLOWS VALVE	ALL	1
-ITEMS ARE NON- ILLUSTRATED				
*ITEMS ARE NON-STOCKED, WILL NORMALLY REQUIRE 2-3 WEEKS LEAD TIME				

# ACCESSORIES

New Construction Accessories		
PDXWSA  PDXWSEXT	<p>WALL SLEEVE Galvanized zinc coated steel is prepared in an 11-step process, then powder coated with a polyester finish and cured in an oven for exceptional durability. The wall sleeve is insulated for sound absorption and thermal efficiency, 16" High x 42" Wide x 13 3/4" Deep.</p> <p>DEEP WALL SLEEVE EXTENSION For use when the wall is thicker than 13 1/4" deep. The wall sleeve may be special ordered through your Sales Representative and will be cut to your specific depth requirements..</p>	
PXGA	GRILLE Standard, stamped aluminium, anodized to resist chalking and oxidation.	
PXAA PXBG PXSC	<p>ARCHITECTURAL GRILLES Consist of heavy-gauge 6063-T5 aluminum alloy:</p> <p>PXAA – Clear, extruded aluminum            PXBG – Beige acrylic enamel            PXSC – Also available in custom colors.</p>	
PXSE	SLEEVE EXTENSION RETROFIT KIT Galvanized zinc coated steel, 2.4" sleeve extension attached to the room side of the sleeve to allow for the installation of a PD-Series Friedrich PTAC in a T-Series sleeve.	
PXSBA	<p>DECORATIVE SUBBASE Provides unit support for walls less than six inches thick. Includes leveling legs, side filler panels and mounting brackets for electrical accessories. Accepts circuit breaker, power disconnect switch, or conduit kit.</p>	
	<p>ELECTRICAL SUBBASE Provides unit support for walls less than six inches thick. Includes leveling legs, side filler panels, mounting brackets, a plug-in receptacle and field-wiring access. The subbase also includes electrical knockouts for a power disconnect switch or circuit breaker.</p> <p>PXSB23020 - Electrical Subbase - 230V 15 &amp; 20A            PXSB23030 - Electrical Subbase - 230V 30A            PXSB26515 - Electrical Subbase - 265V 15A            PXSB26520 - Electrical Subbase - 265V 20A            PXSB26530 - Electrical Subbase - 265V 30A</p>	
POWER CORDS	<p>PXPC23015A LCDI 230V 15A Cord - 2.5 kW 6 ft. length            PXPC23020A LCDI 230V 20A Cord - 3.5 kW 6 ft. length            PXPC23030 LCDI 230V 30A Cord - 5.0 kW 6 ft. length</p>	
	<p>PXPC26515A Non-LCDI 265V 15A Cord - 2.5 kW 18 inch length            PXPC26520A Non-LCDI 265V 20A Cord - 3.5 kW 18 inch length            PXPC26530 Non-LCDI 265V 30A Cord - 5.0 kW 18 inch length</p>	
PXCJA	CONDUIT KIT WITH JUNCTION BOX Hard wire conduit kit with junction box for 208/230V and 265V units (subbase not required). Kit includes a means of quick disconnect for easy removal of the chassis. *Required for 265V installations.	

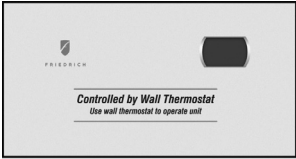
# ACCESSORIES

PDXDAA	<p>LATERAL DUCT ADAPTER Attaches to the Friedrich PTAC/PTHP unit to direct up to 35% of the total airflow to a second room. The unit mounted duct plenum features a front mounted aluminum grille that has two positions to provide the most optimal air direction. The air may be directed to either the left or the right of the unit through the supplied 3.5 H" x 7 W" x 47" L plenum. Plenum may be cut to length by the installer. Kit includes duct plenum, front grille, 47" duct extension, duct discharge grille, duct end cap and all necessary mounting hardware.</p>	
PDXDEA	<p>LATERAL DUCT EXTENSION Additional 3.5 H" x 7" W x 47" L plenum for use with the LATERAL DUCT ADAPTER. A maximum of 3 duct extensions total may be used. Note: Ducted airflow is reduced as duct length is increased.</p>	
PXFTA	<p>REPLACEMENT FILTER PACK These are original equipment return air filters. They are reusable and can be cleaned by vacuuming, washing, or blowing out, and are sold in convenient ten-packs. (Two filters per chassis).</p>	
PXDR10	<p>CONDENSATE DRAIN KIT Attaches to the bottom of the wall sleeve for internal draining of condensate or to the rear wall sleeve flange for external draining. Recommended on all units to remove excess condensate. Packaged in quantities of ten.</p>	
RT7 RT7P	<p>DIGITAL REMOTE WALL THERMOSTAT Single stage cool, single stage heat for PDE models or single stage cool, dual stage heat for PDH model thermostat features high/low fan speed switch. Thermostat is hard wired and can be battery powered or unit powered. Features backlit display and multiple configuration modes. For use on PD-series Friedrich PTACs and Vert-I-Paks.</p>	
WRT2	<p>DIGITAL THERMOSTAT Wireless, single stage, wall-mounted digital thermostat with two fan speeds. Features backlit display and multiple configuration modes.</p>	
PDXRTA	<p>REMOTE THERMOSTAT ESCUTCHEON KIT This kit contains ten escutcheons that can be placed over the factory control buttons when a remote wall mounted thermostat is used. The escutcheon directs the guest to the wall thermostat for operation and retains the LED window to display error codes and diagnostic information.</p>	
	<p>FRIEDRICHLINK® ENERGY MANAGEMENT THERMOSTAT Integrated occupancy sensor uses a combination of motion and thermal sensing technologies for accurate occupancy detection. Reliable occupancy detection allows saving energy when rooms are unoccupied. Energy saving presets eliminate the guesswork and make it easy to adjust the energy saving settings.</p>	
EMWRT2	<p>Wireless thermostat with occupancy sensor.</p>	
EMRT2	<p>Wired thermostat with occupancy sensor.</p>	

# APPENDIX

## Reference Sheet of Celsius and Fahrenheit

Conversion formula for Fahrenheit degree and Celsius degree:  $T_f = T_c \times 1.8 + 32$

Set temperature

Fahrenheit display temperature (°F)	Fahrenheit (°F)	Celsius(°C)	Fahrenheit display temperature (°F)	Fahrenheit (°F)	Celsius (°C)	Fahrenheit display temperature (°F)	Fahrenheit (°F)	Celsius (°C)
61	60.8	16	69/70	69.8	21	78/79	78.8	26
62/63	62.6	17	71/72	71.6	22	80/81	80.6	27
64/65	64.4	18	73/74	73.4	23	82/83	82.4	28
66/67	66.2	19	75/76	75.2	24	84/85	84.2	29
68	68	20	77	77	25	86	86	30

Ambient temperature

Fahrenheit display temperature (°F)	Fahrenheit (°F)	Celsius(°C)	Fahrenheit display temperature (°F)	Fahrenheit (°F)	Celsius(°C)	Fahrenheit display temperature (°F)	Fahrenheit (°F)	Celsius(°C)
32/33	32	0	55/56	55.4	13	79/80	78.8	26
34/35	33.8	1	57/58	57.2	14	81	80.6	27
36	35.6	2	59/60	59	15	82/83	82.4	28
37/38	37.4	3	61/62	60.8	16	84/85	84.2	29
39/40	39.2	4	63	62.6	17	86/87	86	30
41/42	41	5	64/65	64.4	18	88/89	87.8	31
43/44	42.8	6	66/67	66.2	19	90	89.6	32
45	44.6	7	68/69	68	20	91/92	91.4	33
46/47	46.4	8	70/71	69.8	21	93/94	93.2	34
48/49	48.2	9	72	71.6	22	95/96	95	35
50/51	50	10	73/74	73.4	23	97/98	96.8	36
52/53	51.8	11	75/76	75.2	24	99	98.6	37
54	53.6	12	77/78	77	25			

# APPENDIX

## Resistance Table of THERMISTORS (5K)

Temp	Resis	Temp	Resis	Temp	Resis	Temp	Resis	Temp	Resis
-33	130100	7	34252	47	10785	57	8275	97	3119
-32	125518	8	33209	48	10499	58	8063	98	3048
-31	121114	9	32202	49	10221	59	7857	99	2980
-30	116881	10	31228	50	9952	60	7657	100	2913
-29	112811	11	30288	51	9690	61	7462	101	2848
-28	108898	12	29378	52	9437	62	7273	102	2785
-27	105131	13	28499	53	9190	63	7090	103	2723
-26	101511	14	27650	54	8952	64	6911	104	2662
-25	98029	15	26828	55	8720	65	6738	105	2604
-24	94676	16	26034	56	8494	66	6569	106	2546
-23	91453	17	25266	57	8275	67	6406	107	2491
-22	88349	18	24523	58	8063	68	6247	108	2436
-21	85362	19	23805	59	7857	69	6092	109	2383
-20	82486	20	23110	60	7657	70	5942	110	2331
-19	79719	21	22437	61	7462	71	5796	111	2281
-18	77052	22	21787	62	7273	72	5654	112	2231
-17	74486	23	21158	63	7090	73	5515	113	2183
-16	72014	24	20548	64	6911	74	5381	114	2137
-15	69633	25	19959	65	6738	75	5251	115	2091
-14	67338	26	19388	66	6569	76	5124	116	2046
-13	65127	27	18836	67	6406	77	5000	117	2003
-12	62996	28	18301	68	6247	78	4880	118	1960
-11	60943	29	17783	69	6092	79	4763	119	1919
-10	58965	30	17282	70	5942	80	4649	120	1878
-9	57055	31	16796	71	5796	81	4538	121	1839
-8	55216	32	16325	72	5654	82	4431	122	1800
-7	53442	33	15870	73	5515	83	4326	123	1763
-6	51732	34	15428	74	5381	84	4224	124	1726
-5	50082	35	15001	75	5251	85	4125	125	1690
-4	48490	36	14586	76	5124	86	4028	126	1655
-3	46955	37	14184	77	5000	87	3934	127	1621
-2	45473	38	13795	48	10499	88	3842	128	1588
-1	44044	39	13418	49	10221	89	3753	129	1555
0	42664	40	13052	50	9952	90	3666	130	1524
1	41332	41	12698	51	9690	91	3582	131	1493
2	40047	42	12354	52	9437	92	3499	132	1462
3	38805	43	12021	53	9190	93	3419	133	1433
4	37607	44	11698	54	8952	94	3341	134	1404
5	36450	45	11384	55	8720	95	3265	135	1375
6	35332	46	11080	56	8494	96	3191	136	1348

# APPENDIX

**Resistance Table of Thermistors (5K) (Continued)**

Temp	Resis	Temp	Resis	Temp	Resis	Temp	Resis	Temp	Resis
137	1321	162	812	187	517	212	339	237	229
138	1294	163	797	188	508	213	334	238	226
139	1269	164	782	189	499	214	329	239	222
140	1244	165	768	190	491	215	323	240	219
141	1219	166	754	191	482	216	318	241	216
142	1195	167	740	192	474	217	313	242	212
143	1171	168	727	193	466	218	308	243	209
144	1148	169	713	194	458	219	303	244	206
145	1126	170	700	195	450	220	298	245	203
146	1104	171	688	196	443	221	294	246	200
147	1083	172	675	197	435	222	289	247	197
148	1062	173	663	198	428	223	285	248	194
149	1041	174	651	199	421	224	280	249	191
150	1021	175	640	200	414	225	276	250	189
151	1001	176	628	201	407	226	271		
152	982	177	617	202	400	227	267		
153	964	178	606	203	394	228	263		
154	945	179	595	204	387	229	259		
155	927	180	585	205	381	230	255		
156	910	181	574	206	374	231	251		
157	893	182	564	207	368	232	247		
158	876	183	554	208	362	233	244		
159	859	184	545	209	356	234	240		
160	843	185	535	210	351	235	236		
161	828	186	526	211	345	236	233		



Friedrich Air Conditioning Co.  
10001 Reunion Place, San Antonio, TX 78216  
800.541.6645  
www.friedrich.com

## PZ-SERIES PACKAGED TERMINAL AIR CONDITIONERS LIMITED WARRANTY

**SAVE THIS CERTIFICATE.** It gives you specific rights. You may also have other rights which may vary from state to state and province to province. In the event that your unit needs servicing, contact your nearest authorized service center. If you do not know the nearest service center, ask the company that installed your unit or contact us - see address and telephone number above. To obtain service and/or warranty parts replacement, you must notify an authorized FRIEDRICH Air Conditioning Co. service center, distributor, dealer, or contractor of any defect within the applicable warranty period.

**When requesting service:** please have the model and serial number from your unit readily available.

Unless specified otherwise herein, the following applies:  
**FRIEDRICH PACKAGED TERMINAL AIR CONDITIONERS AND  
HEAT PUMPS**

**LIMITED WARRANTY - FIRST YEAR (Twelve (12) months from the date of installation).** Any part found to be defective in the material or workmanship will be repaired or replaced free of charge by our authorized service center during the normal working hours; and

**LIMITED WARRANTY - SECOND THROUGH FIFTH YEAR (Sixty (60) months from the date of installation). ON THE SEALED REFRIGERATION SYSTEM.** Any part of the sealed refrigeration system that is defective in material or workmanship will be repaired or replaced free of charge (excluding freight charges) by our authorized service center during normal working hours. The sealed refrigeration system consists of the compressor, metering device, evaporator, condenser, reversing valve, check valve, and the interconnecting tubing.

**These warranties apply only while the unit remains at the original site and only to units installed inside the continental United States, Alaska, Hawaii, Puerto Rico, Mexico and Canada. The warranty applies only if the unit is installed and operated in accordance with the printed instructions and in compliance with applicable local installation and building codes and good trade practices. For international warranty information, contact the Friedrich Air Conditioning Company - International Division.**

Any defective part to be replaced must be made available to **FRIEDRICH** in exchange for the replacement part. Reasonable proof must be presented to establish the date of install, otherwise the beginning date of this certificate will be considered to be our shipment date plus sixty days. Replacement parts can be new or remanufactured. Replacement parts and labor are only warranted for any unused portion of the unit's warranty.

We will not be responsible for and the user will pay for:

1. Service calls to:
  - A) Instruct on unit operation.
  - B) Replace house fuses or correct house wiring.
  - C) Clean or replace air filters.
  - D) Remove the unit from its installed location when not accessible for service required.
  - E) Correct improper installations.
2. Parts or labor provided by anyone other than an authorized service center.
3. Damage caused by:
  - A) Accident, abuse, negligence, misuse, riot, fire, flood, or acts of God.
  - B) Operating the unit where there is a corrosive atmosphere containing chlorine, fluorine, or any damaging chemicals (other than in a normal residential environment).
  - C) Unauthorized alteration or repair of the unit, which in turn affects its stability or performance.
  - D) Failing to provide proper maintenance and service.
  - E) Using an incorrect power source.
  - F) Faulty installation or application of the unit.
  - G) Operation of the unit during Construction**

**We shall not be liable for any incidental, consequential, or special damages or expenses in connection with any use or failure of this unit. We have not made and do not make any representation or warranty fitness for a particular use or purpose and there is no implied condition of fitness for a particular use or purpose. We make no expressed warranties except as stated in this certificate. No one is authorized to change this certificate or to create for us any other obligation or liability in connection with this unit. Any implied warranties shall last for one year after the original purchase date.** Some states and provinces do not allow limitations on how long an implied warranty or condition lasts, so the above limitations or exclusions may not apply to you. The provisions of this warranty are in addition to and not a modification of or subtraction from the statutory warranties and other rights and other rights and remedies provided by law.

**Performance of Friedrich's Warranty obligation is limited to one of the following methods:**

1. Repair of the unit
2. A refund to the customer for the prorated value of the unit based upon the remaining warranty period of the unit.
3. Providing a replacement unit of equal value

**The method of fulfillment of the warranty obligation is at the sole discretion of Friedrich Air Conditioning.**

**In case of any questions regarding the provisions of this warranty, the English version will govern.**

---

## CUSTOMER SATISFACTION and QUALITY ASSURANCE

Friedrich is a conscientious manufacturer, concerned about customer satisfaction, product quality, and controlling warranty costs. As an Authorized Service Provider you play a vital role in these areas. By adhering to the policies and procedures you provide us with vital information on each warranty repair you complete. This information is used to identify product failure trends, initiate corrective action, and improve product quality, thereby further reducing warranty expenses while increasing customer satisfaction levels.

## FRIEDRICH AUTHORIZED PARTS DEPOTS

### **AAA Refrigeration Service**

1322 24th Street, Suite B Kenner,  
Louisiana 70062 504-464-7444  
877-813-7444

### **Alamo Service Company**

1450 North Flores Street San  
Antonio, Texas 78212 210-227-  
2450  
800-328-2450

### **The Gabbert Company**

6868 Ardmore  
Houston, Texas 77054

713-747-4110  
800-458-4110

### **Johnstone Supply of Woodside**

27-01 Brooklyn Queens Expway  
Woodside, New York 11377 718-  
545-5464  
800-431-1143

### **Reeve Air Conditioning, Inc.**

2501 South Park Road Hallandale, Florida  
33009 954-962-0252  
800-962-3383



# FRIEDRICH

## TECHNICAL SUPPORT CONTACT INFORMATION

Friedrich Air Conditioning Co.  
10001 Reunion Place, Suite 500 • San Antonio, Texas 78216  
1-800-541-6645  
[www.friedrich.com](http://www.friedrich.com)