

Installation Guide

Please visit <https://www.follettice.com/technicaldocuments> for the Operation and Service manual for your unit.

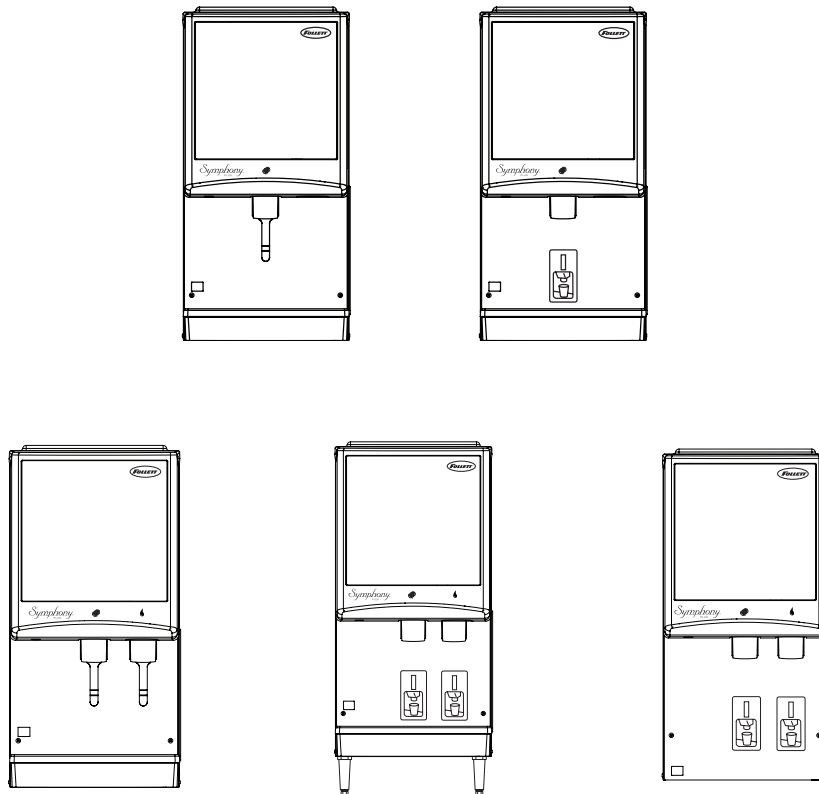

Welcome to Follett

Follett equipment enjoys a well-deserved reputation for excellent performance, long-term reliability and outstanding after-the-sale support. To ensure that this equipment delivers that same degree of service, review this guide carefully before you begin your installation.

Should you have need technical help, please call our Technical Service group at (877) 612-5086 or (610) 252-7301.

Please have your model number, serial number and complete and detailed explanation of the problem when contacting Technical Service.

Getting Started

After uncrating and removing all packing material. Inspect the equipment for concealed shipping damage. All freight is to be inspected upon delivery. If visible signs of damage exist, please refuse delivery or sign your delivery receipt "damaged." Follett Customer Service must be notified within 48 hours. Wherever possible, please include detailed photos of the damage with the original packaging so that we may start the freight claim process.

⚠ CAUTION!

- Do not tilt unit further than 30° off vertical during uncrating or installation.
- Dispenser bin area contains mechanical, moving parts. Keep hands and arms clear of this area at all times. If access to this area is required, power to unit must be disconnected first.
- Follett recommends a Follett water filter system be installed in the ice machine inlet water line (standard capacity #00130229, high capacity #00978957, carbonless high capacity #01050442).
- Prior to operation, clean the dispenser in accordance with instructions found in this manual.
- Ice is slippery. Be sure counters and floors around dispenser are clean, dry and free of ice.
- Do not block right side air intake or top air exhaust.

Specifications

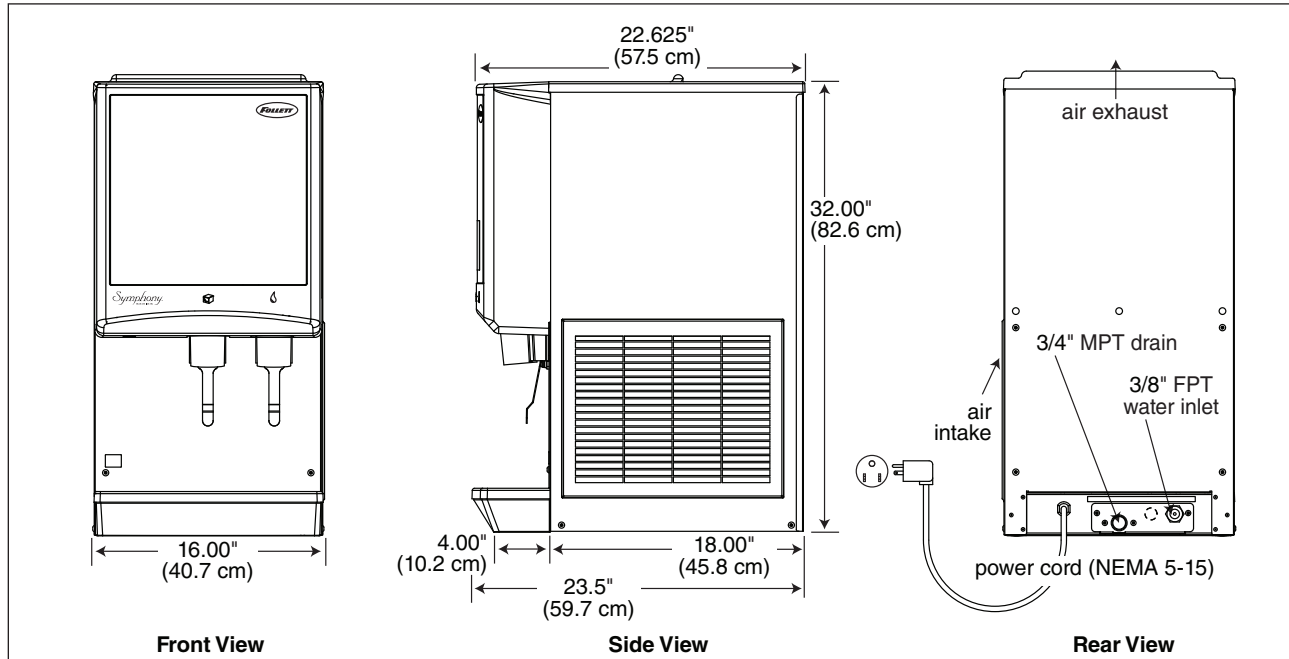

Electrical

- 115 V, 60 Hz, 1 phase, 11.0A
- Connect to a 15A dedicated circuit.

Ambient

Air temp*	100 F/38 C Max.	50 F/10 C Min. Best performance below 80 F (27 C)
Water temp†	90 F/32 C Max.	45 F/4 C Min. Best performance below 70 F (21 C)
Water pressure (psi/bar)	70/5 Max.	10/0.7 Min.

* Ambient air temperature is measured at the air-cooled condenser coil inlet.

† Ambient water temperature is measured in the ice machine reservoir.

Plumbing

	12CI425A	12HI425A
Dispenser drain	3/4" MPT	3/4" MPT
Water inlet	3/8" FNPT	3/8" FNPT

Note: Water shut-off recommended within 10 ft. (3 m) of dispenser. Drain to be hard-piped and insulated. Maintain at least 1/4" per foot (20 mm per 1 m) run of slope.

Ventilation clearances

- 6" (15.3 cm) on right side of dispenser, 6" (15.3 cm) at top, and 12" (30.5 cm) at top recommended for service.

Note: Do not block right side air intake or top air exhaust.

Dry weight

- 144 lb (65 kg)

Refrigeration system

Important: All service on refrigeration system must be performed in accordance with all federal, state and local laws that pertain to the use of refrigerants. It is the responsibility of the technician to ensure that these requirements are met.

R425 ice machine charge specifications

Model	Charge	Refrigerant type
12CI425A, 12HI425A (air-cooled)	15 oz	R404A

Refrigeration pressure data

Air-cooled ice machine capacity/24 hrs.

Ambient Air Temperature °F/°C

Inlet Water Temperature °F/°C	F	60	70	80	90	100	
	C	16	21	27	32	38	
50	460	425	390	355	320	lbs.	
10	208	193	177	161	145	kg.	
60	437	405	372	340	307	lbs.	
16	198	184	169	154	139	kg.	
70	415	385	355	325	295	lbs.	
21	188	175	161	147	134	kg.	
80	405	375	345	315	285	lbs.	
27	184	170	156	142	129	kg.	
90	395	365	335	305	275	lbs.	
32	179	166	152	138	125	kg.	

Compressor data

Compressor current draw

Air-cooled

Air temp (F)	60	70	80	90	100
Comp Amperage (A)	5.8	6.1	6.2	6.2	6.3
High-side Pressure (psi)	190	220	250	290	330
Low-side Pressure (psi)	27	29	31	33	36

Locked rotor amps 48A

Gearmotor Data	Split-Phase	PSC (permanent split capacitor)
Gearmotor current	1.8A-1.9A (nominal)	0.8A-0.9A (nominal)
Locked rotor amps	14A	7A-14A (temperature dependent)

Installation

Before you begin

- All dispensers must be installed level in both directions to ensure proper operation.
- Service and ventilation clearances: 6" (15.3 cm) on right side of dispenser, 6" (15.3 cm) at top for ventilation and 12" (30.5 cm) at top recommended for service.
- Countertop units installed without legs provide the option of taking utilities out bottom or back of dispenser (on wall mount units and countertop units with legs, utilities exit from back). See counter cutout drawings for bottom exiting utilities. For installations where utilities exit through back of dispenser, refer to back view drawings.
- Wall mount models without drain pan are designed for use above sinks.
- Counter depth must allow front of sink to be a minimum of 30.00" (76.2 cm) from wall.

Installing countertop dispensers without legs

1. Position dispenser in desired location, mark dispenser outline on counter and remove dispenser.
2. Regardless of whether utilities will exit through back or bottom of dispenser, drill four 7/16" holes in counter to anchor dispenser to counter (**Fig. 1**).
3. **For utilities exiting through bottom only:**
 - (a) Make cut out (**Fig. 1**).
 - (b) Move drain fitting from back of dispenser and mount (**Fig. 2**).
 - (c) Cut drain tube to length and attach to barbed connection.
 - (d) Move inlet water fitting from back of dispenser and mount (**Fig. 2**).
 - (e) Cut water tubing to length and re-insert into water fitting.
4. **For all units:** Apply a thick bead approximately 1/4" (7 mm) diameter of NSF-listed silicone sealant (Dow Corning RTV-732® or equivalent) 1/4" (7 mm) inside marked outline of dispenser.
5. Carefully lower dispenser on counter in proper position and secure to counter with four (4) 3/8"-16UNC bolts.
6. Smooth excess sealant around outside of dispenser.

Fig. 1

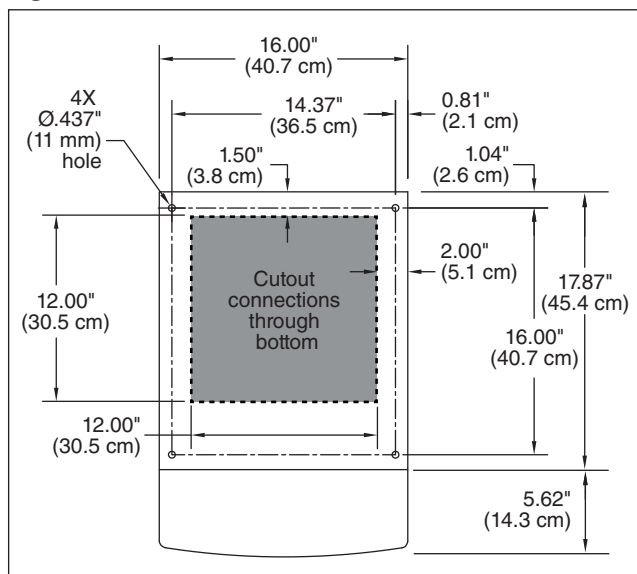
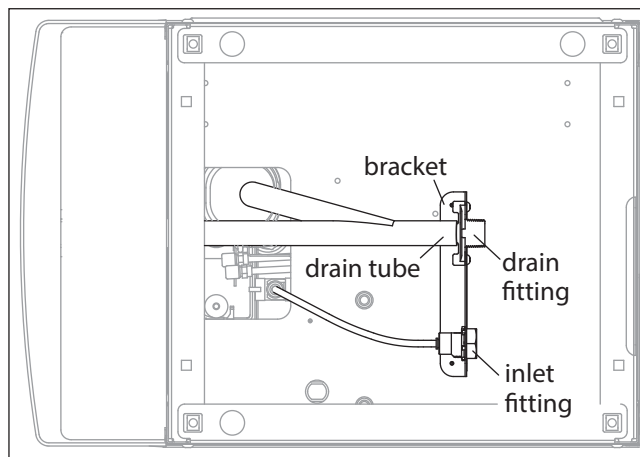

Fig. 2 - Bottom exiting utilities (countertop units)



Installing countertop dispensers with legs accessory (P/N AF10LBLEGS)



CAUTION!

- Do not tilt unit further than 30° off vertical plane.
- Countertop dispensers that sit on legs (not bolted to counter) can be inadvertently moved. Care should be taken when operating and cleaning to avoid accidents.

1. Carefully tip dispenser back to expose underside and block up in place.
2. Screw legs (shipped taped to drain pan of dispenser) into dispenser bottom, taking care to seat legs securely against underside of dispenser.
3. Attach bottom panel and hardware to bottom of dispenser with supplied screws (**Fig. 3**).
4. Position unit in desired location and adjust legs to level in both directions.
5. Make final connections.

Fig. 3 - Bottom panel and leg assembly

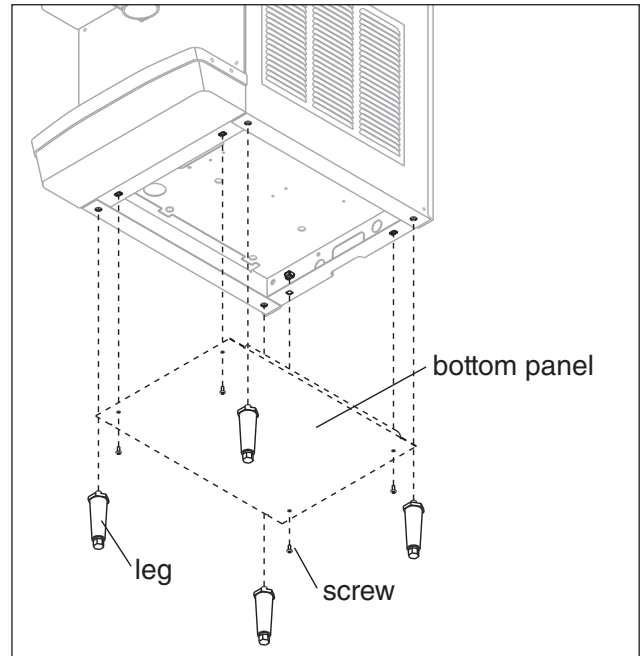

Installing wall mount dispensers



- **WALL PREPARATION:** Wall and fasteners must be of sufficient strength to carry weight of unit (185 lb (83.9 kg)). Hardware for this is not included.

Notes:

- SensorSAFE™ infrared dispensing is standard.
1. Recommended minimum counter depth and mounting height (**Fig. 6**) ensures that ice will drop into sink.
 2. See **Fig. 6** for model dimensions. The dimensions include the 0.5" (13 mm) mounting bracket supplied with the unit.
 3. Cut utility hole in wall as shown (**Fig. 5**).
 4. Mount support bracket to wall using fasteners of sufficient strength (fasteners not included, see **Fig. 4**).
 5. Rough in water and drain lines (3/4" copper recommended for drain) (**Fig. 9**).
 6. Lift dispenser onto support bracket, positioning unit so that hook on back of dispenser is captured by support bracket angle (**Fig. 6**).
 7. Install two (2) supplied 3/8"-16UNC screws through bottom of support bracket into bottom of dispenser (**Fig. 4**). Slotted holes in support bracket allow you to adjust and level the dispenser. Ensure that the top of dispenser is level or tilted slightly back toward the wall.
 8. Remove bottom cover and make final connections (**Fig. 7**).
 9. Attach bottom panel and hardware to bottom of dispenser (**Fig. 8**).
 10. Clean dispenser prior to use.

Fig. 4 – Wall mount bracket and fastener requirements

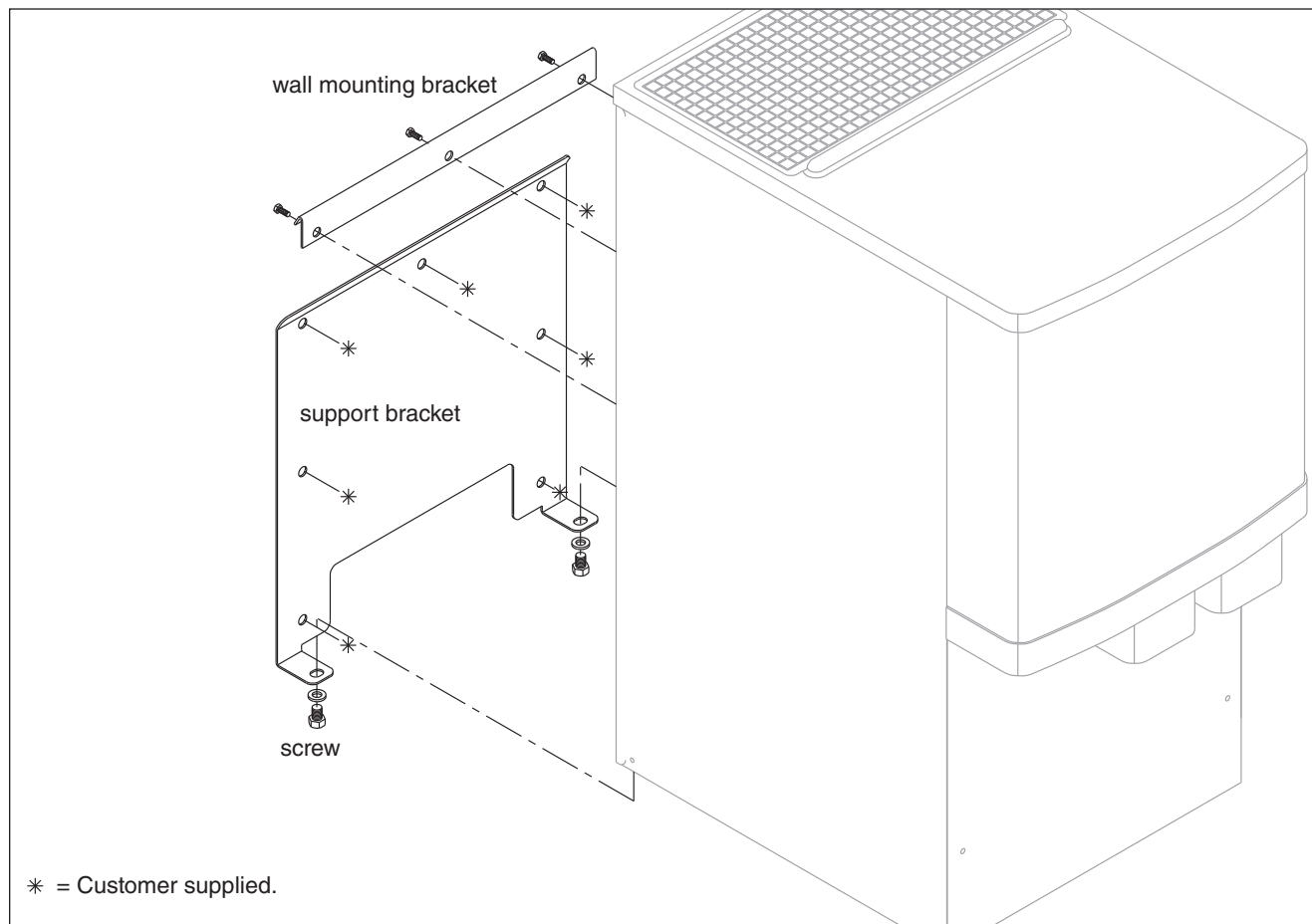

Fig. 5 – Wall mount dimensions

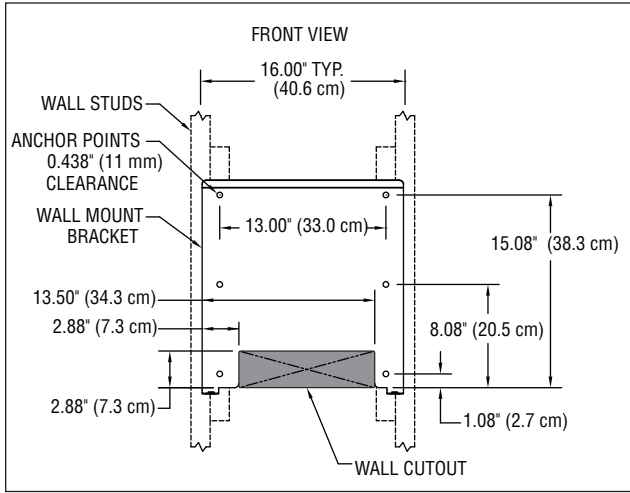
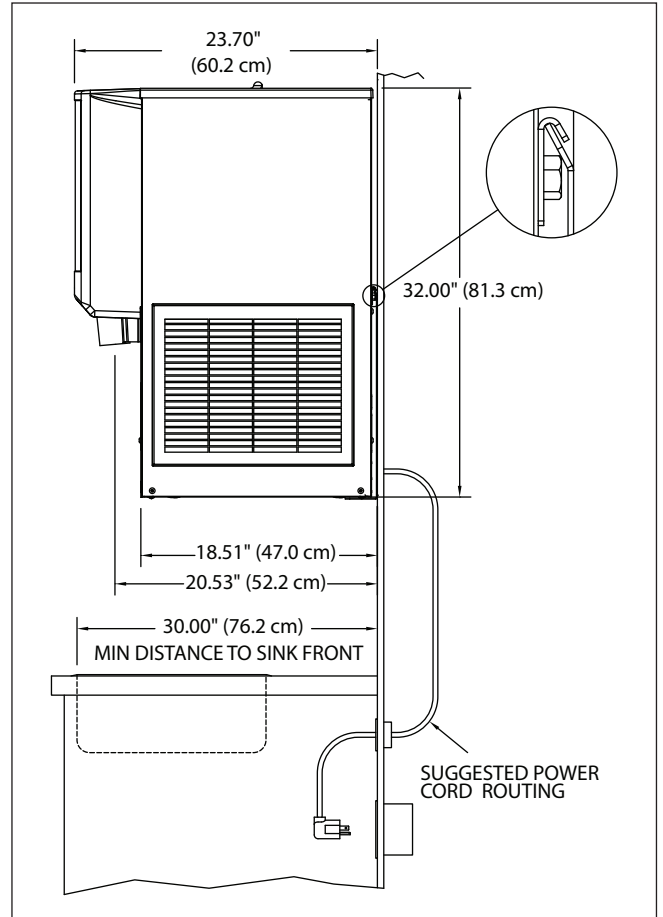

Fig. 6 – Wall mount side view



CAUTION!

- Do not rest dispenser weight on bottom of support bracket. Dispenser weight to rest on top of the support bracket (Fig. 6).

Fig. 7 – Wall mount unit bottom panel assembly

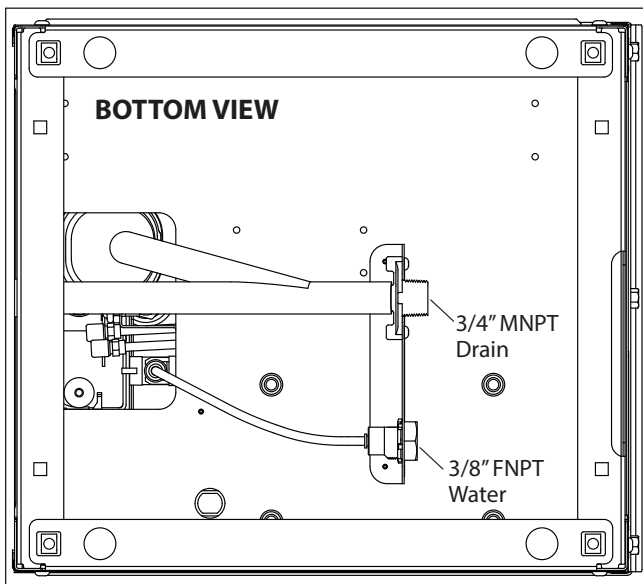

Fig. 8 – Wall mount unit bottom panel assembly

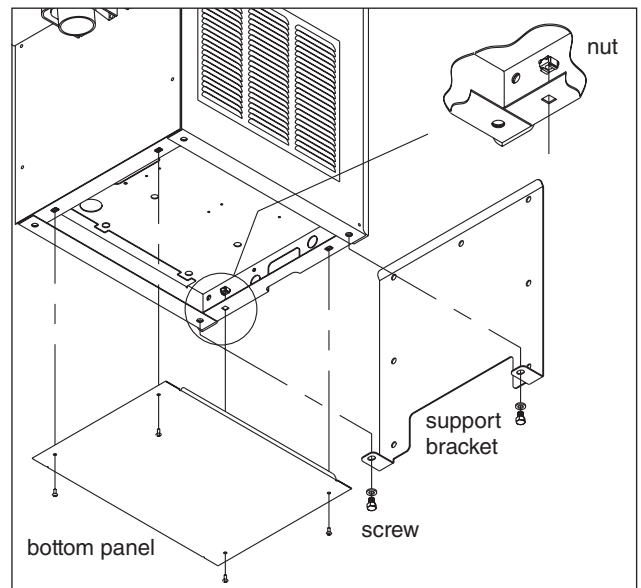
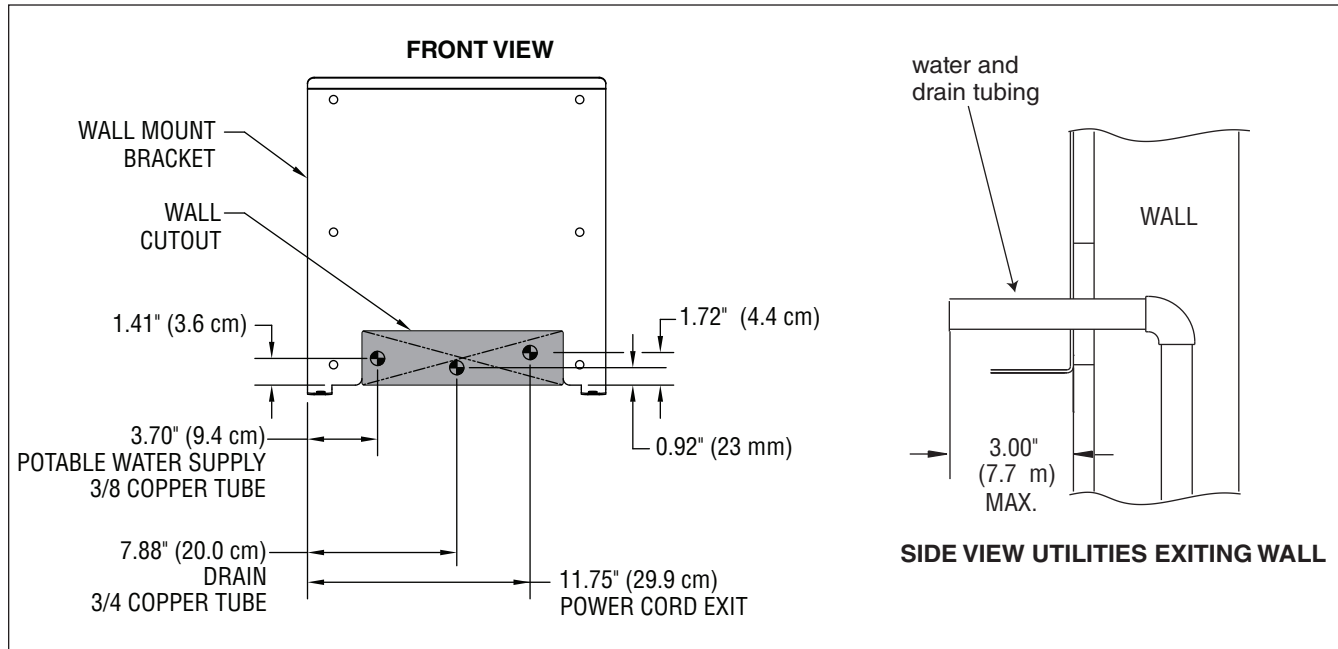

Fig. 9 – Wall mount, utility location



Cleaning and sanitizing

Follett ice machines and dispensers, and their associated cleaning and sanitizing procedures, are designed for use with potable water sources. The presence, or suspected presence, of infectious agents may call for additional measures, including the replacement of components and more comprehensive disinfection measures. Follett recommends that these cleaning and sanitizing procedures be reviewed with the appropriate infectious agent subject matter experts to assure complete remediation.

Periodic cleaning of Follett's ice and water dispenser and ice machine system is required to ensure peak performance and delivery of clean, sanitary ice. The recommended cleaning procedures that follow should be performed at least as frequently as recommended and more often if environmental conditions dictate.

Follett recommends sanitizing the pressurized water lines prior to cleaning the ice machine/dispenser. Follett offers two kits: order P/N [01089572](#) when a Follett filter system with a pre-filter bowl is present, or P/N [01089580](#) when a Follett filter system is not present. Follow the instructions provided with the respective kits to sanitize the pressurized water lines immediately before cleaning the ice machine/dispenser.

Cleaning of the condenser can usually be performed by facility personnel. Cleaning of the ice machine system should be performed by your facility's trained maintenance staff or a Follett authorized service agent. Regardless of who performs the cleaning, it is the operator's responsibility to see that this cleaning is performed according to the schedule below. Service problems resulting from lack of preventive maintenance will not be covered under the Follett warranty.

Recommended cleaning intervals*

Symphony Plus	Frequency
Drain Line	weekly
Drain Pan/Drip Pan	weekly
Exterior	as needed
Condenser	monthly (air-cooled only)
Dispenser and Components	semi-annually
Ice Machine	semi-annually
Transport Tube	semi-annually
Ice Storage Area/Bin	semi-annually
Pressurized Water Sanitizing	semi-annually

* Ice machine and dispenser must be cleaned prior to start-up.

Weekly



- Do not use solvents, abrasive cleaners, metal scrapers or sharp objects to clean any part of the dispenser.

Dispenser drain pan and drain line

- Pour 1 gal. (3.8 L) of hot tap water into drain pan to flush drains.

Splash panel front, SensorSAFE infrared dispensing

- Deactivate dispensing by pressing and releasing clean switch located on left side of unit under top front cover.
- Clean lens and splash panel front using a soft cloth and mild, non-abrasive, non-chlorine based cleaner.
- Reactivate dispensing by pressing and releasing clean switch again.

Monthly



- Do not use solvents, abrasive cleaners, metal scrapers or sharp objects to clean any part of the dispenser.

Condenser (air-cooled ice machine only)

- Use a vacuum cleaner or stiff brush to carefully clean condenser coils of lint and debris to ensure optimal performance.

Semi-Annually (more often if conditions dictate)

- A cleaning procedure should always include both the ice machine and dispenser.
- Icemaking system can be cleaned in place.



- Wear rubber gloves and safety goggles (or face shield) when handling SafeCLEAN Plus and IMS-III solutions.
- Use only Follett approved cleaners.
- It is a violation of Federal law to use the Nu-Calgon® IMS-III solution in a manner inconsistent with its labeling.
- Do not use solvents, abrasive cleaners, metal scrapers or sharp objects to clean any part of the dispenser.

Cleaning & sanitizing tool checklist

- (1 or 2) 1.5 gallon (or larger) plastic bucket
- (2) clean cloths
- Sanitary gloves
- Safety glasses
- (2) SaniSponge™ (P/N [00131524](#) - single sponge)
- SafeCLEAN Plus ice machine cleaner
- [OPTIONAL] Nu-Calgon IMS-III no-rinse sanitizer (P/N [00979674](#) – 16 fl oz. bottle)

SafeCLEAN Plus Solution: Follow the directions on the SafeCLEAN Plus packaging to mix 1 gal. (3.8 L) of Follett SafeCLEAN Plus solution. Use 100 F (38 C) water.

[OPTIONAL] No-rinse Sanitizing Solution: Follow the directions on the Nu-Calgon IMS-III packaging to mix 1 gal. (3.8 L) of sanitizing solution. Use 100 F (38 C) water.

Ice Machine and Dispenser

Cleaning procedure

Note: Check drains and drain cup to ensure they are open and flowing freely.

1. If ice machine was running recently, ensure that the evaporator is completely free of ice before proceeding. If there is ice in the evaporator, complete steps 2-7 using only hot water to remove the ice then begin Cleaning Procedure again.
2. Remove front cover and turn OFF bin signal switch.
3. Dispense all ice from storage hopper and discard.
4. Remove top of machine and hopper lid.
5. Press **CLEAN** switch. The **MAINTENANCE** light will turn on and the machine will drain. Wait for the **LOW WATER** light to turn on.
6. Remove lid from cleaning cup and fill (about 1 quart) until SafeCLEAN Plus solution overflows from the ice transport tube into the hopper. Place lid back on cup. Save remainder of SafeCLEAN Plus solution.
7. **CLEANER FULL** light will turn on and machine will start cleaning cycle then rinse three times; this process takes approximately 15 minutes.

8. While ice machine is cleaning, clean dispenser as follows:
 - a. Remove center thumbscrew, locking plate, two wingnuts and backing plate from front of storage hopper.
 - b. Remove stud assembly, baffle, wheel, and any remaining ice.
 - c. Remove dispense chutes from splash panel.
 - d. Submerge drain grille in SafeCLEAN Plus solution and allow to soak to remove any scale buildup.
 - e. Wipe inside of hopper lid, stud assembly, baffle, wheel, inside of storage area, dispense chutes, drain grille and drain pan with damp cloth wrung out in SafeCLEAN Plus solution. Thoroughly rinse all parts with damp cloth wrung out with clean water.

Note: To avoid possible damage to motor assembly, only use a damp cloth to clean storage hopper. Do not allow water to run through motor shaft hole in bottom of hopper.
9. When machine is finished cleaning, the **MAINTENANCE** light will turn off.

Finish cleaning – SafeCLEAN Plus only

10. Reinstall dispense chutes, wheel, baffle, stud assembly and knurled nuts.
11. Remove top bearing insulation. Loosen Phillips-head screw on nozzle connected to evaporator. Remove nozzle from evaporator side only, leave other side of nozzle connected to transport tube.
12. Soak one SaniSponge in remaining SafeCLEAN Plus solution.
13. Insert the sponge soaked in SafeCLEAN Plus solution into nozzle then insert a dry sponge into the nozzle.
14. Replace nozzle onto evaporator and tighten screw. Ensure drain is connected to reservoir and vent tubes are connected to evaporator drain pan. Replace top bearing insulation.
15. Turn ON bin signal switch. Wait for ice to push sponges through transport tube.
16. Collect sponges from ice storage bin.
17. Replace hopper lid, machine top, and install front cover.
18. After 10 minutes, dispense all ice and discard.

[OPTIONAL] Finish cleaning – No-rinse sanitizing with Nu-Calgon IMS-III

10. Press **CLEAN** switch. The **MAINTENANCE** light will turn on and the machine will drain. Wait for the **LOW WATER** light to turn on.
11. Remove lid from cleaning cup and fill (about 1 quart) until sanitizing solution overflows from the ice transport tube into the hopper. Place lid back on cup. Save remainder of sanitizing solution.
12. **CLEANER FULL** light will turn on and machine will start sanitizing cycle then rinse three times; this process takes approximately 15 minutes.
13. While ice machine is sanitizing, sanitize dispenser as follows:
 - a. Wipe inside of hopper lid, stud assembly, baffle, wheel, inside of storage area, dispense chutes, drain grille and drain pan with damp cloth wrung out in sanitizing solution. Do not rinse off the sanitizing solution.

Note: To avoid possible damage to motor assembly, only use a damp cloth to clean storage hopper. Do not allow water to run through motor shaft hole in bottom of hopper.
14. Reinstall dispense chutes, wheel, baffle, stud assembly and knurled nuts.
15. When machine is finished rinsing, the **MAINTENANCE** light will turn off.
16. Remove top bearing insulation. Loosen Phillips-head screw on nozzle connected to evaporator. Remove nozzle from evaporator side only, leave other side of nozzle connected to transport tube.
17. Soak one SaniSponge in remaining sanitizing solution.
18. Insert the sponge soaked in sanitizing solution into nozzle then insert a dry sponge into the nozzle.
19. Replace nozzle onto evaporator and tighten screw. Ensure drain is connected to reservoir and vent tubes are connected to evaporator drain pan. Replace top bearing insulation.
20. Turn ON bin signal switch. Wait for ice to push sponges through transport tube.
21. Collect sponges from ice storage bin.
22. Replace hopper lid, machine top, and install front cover.
23. After 10 minutes, dispense all ice and discard.

User Interface and Exterior Cabinet

- Clean stainless steel panels with stainless steel cleaner.

Electrical system



ATTENTION!

To prevent circuit breaker overload, wait 15 minutes before restarting this unit. This allows the compressor to equalize and the evaporator to thaw.

Normal control board operation

The PC board indicator lights provide all the information necessary to determine the machine's status. Green indicator lights generally represent "go" or normal operation; Yellow indicators represent normal off conditions; Red indicators generally represent alarm conditions, some of which will lock the machine off.

A flashing green light labeled POWER indicates power to the machine. All other normal operation status indicators are covered as follows:

Ice machine disposition	Operating conditions
Legend: ● ON ○ OFF ◐ ON or OFF ◑ FLASHING	
1. Ice machine is making ice. CLEANER FULL ○ DRAIN CLOG ○ HI PRESS ○ HI AMPS ○ SERVICE ○ MAINT/CLEAN ○ LOW WATER ○ TIME DELAY ○ SLEEP CYCLE ○ MAKING ICE ● LOW BIN ● POWER ON ◑	1. Normal running.
2. Ice machine is not making ice. CLEANER FULL ○ DRAIN CLOG ○ HI PRESS ○ HI AMPS ○ SERVICE ○ MAINT/CLEAN ○ LOW WATER ○ TIME DELAY ● SLEEP CYCLE ○ MAKING ICE ○ LOW BIN ◐ POWER ON ◑	2. Normal time delay. When the bin fills with ice, the LOW BIN light goes out momentarily and the refrigeration and auger drive systems immediately shut down. (Note: The fan motor will continue to run for 10 minutes to cool condenser) The TIME DELAY light comes on, initiating the time delay period. When the time delay expires, the machine will restart provided that the LOW BIN light is on.

Control board DIP switch settings

OFF POSITION ON POSITION

	OFF	ON	
[Sleep cycle disabled]	1 <input type="checkbox"/>	1 <input checked="" type="checkbox"/>	[Sleep cycle enabled]
Not used	2 <input type="checkbox"/>	2 <input checked="" type="checkbox"/>	Not used
[Sleep cycle dispense duration]	3 <input type="checkbox"/>	3 <input checked="" type="checkbox"/>	[Sleep cycle dispense duration]
20 min. time delay	4 <input type="checkbox"/>	4 <input checked="" type="checkbox"/>	60 min. time delay
Flush disabled	5 <input type="checkbox"/>	5 <input checked="" type="checkbox"/>	Flush enabled
Maint. timer ON	6 <input type="checkbox"/>	6 <input checked="" type="checkbox"/>	Maint. timer OFF
	7 <input type="checkbox"/>	7 <input checked="" type="checkbox"/>	
	8 <input type="checkbox"/>	8 <input checked="" type="checkbox"/>	

Sleep cycle dispense duration

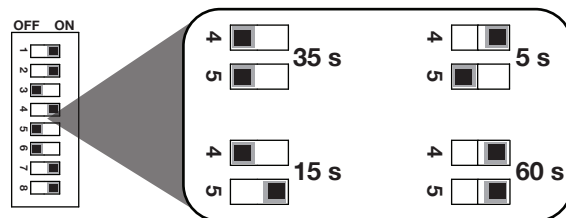

Dispenser troubleshooting



CAUTION!

- Disconnect power to unit before putting hands or arms in storage area or attempting any repair or service to equipment.

Before calling for service

1. Check that no ice is in the dispenser bin area.
2. Check that congealed ice is not causing a jam.
3. Check that all switches and circuit breakers are on.
4. Check that all drains are clear.
5. Check that water is supplied.

Lever model troubleshooting guide

Problem	Indicators	Corrective Action
Does not dispense ice.	<ol style="list-style-type: none"> 1. Power switch off or faulty. 2. Faulty dispense switch. 3. Wheel motor malfunction. 	<ol style="list-style-type: none"> 1. Check switch – turn on or replace if faulty. 2. Replace switch. 3. Check motor and replace
Dispense wheel rotates continuously.	Dispense switch contacts are burned out.	Replace dispense switch.
Ice machine runs continuously.	Faulty or incorrectly positioned bin stat.	Check for proper positioning. If stat does not open when ice is placed on capillary tube, replace stat.
Does not dispense water.	<ol style="list-style-type: none"> 1. Faulty water solenoid valve. 2. Faulty dispense switch. 3. Power switch off or faulty. 	<ol style="list-style-type: none"> 1. Replace water solenoid valve. 2. Replace dispense switch. 3. Check switch - turn on or replace if faulty.

SensorSAFE model troubleshooting guide

Problem	Action	SensorSAFE Board LED Status			Corrective Action
		PWR	CLN	ICE/WTR	
Does not dispense ice and/or water.	Check LEDs on the SensorSAFE control board.	OFF	OFF	OFF	Check circuit breakers and power switch. Restore power or replace defective switch.
		ON	ON	OFF	Press clean switch on lower left side of electrical enclosure to return board to normal operation.
	Place cup under drop zone (in front of lens)	ON	OFF	OFF	Troubleshoot appropriate lens/sensor and replace if required.
		ON	OFF	ON	Verify power on appropriate output terminal (WTR or WM) on control board and replace board if required. If board tests okay, troubleshoot appropriate dispenser component.
Dispenses ice and/or water continuously.	Check LEDs on control board.	ON	OFF	ON	Troubleshoot appropriate lens/sensor and replace if required.
		ON	OFF	OFF	If there is power on any output terminal (WTR or WM) on control board, replace board.

Warranty Registration and Equipment Evaluation

Thank you for purchasing Follett® equipment. Our goal is to deliver high value products and services that earn your complete satisfaction by delivering high-value products and services backed by outstanding customer and technical support.

Please review the installation instructions thoroughly. It is important that the installation be performed to factory specifications so your equipment operates at its maximum efficiency.

Follett LLC will not be liable for any consequential damages, expenses, connecting or disconnecting charges, or any losses resulting from a defect of the machine. For full warranty details, visit our website www.follettice.com/productwarranties.

Registering your equipments helps Follett track your equipment's service history should you need to contact us for technical support, and your feedback helps us improve our products and services. Please visit www.follettice.com/support to complete the Warranty Registration form.

Should you have any questions, please contact Follett's technical support group at (877) 612-5086 or (610) 252-7301 and we will be happy to assist you.

Calgon is a licensed trademark distributed by Nu-Calgon, in the United States.

Dow Corning is a registered trademark of Dow Corning Corporation in the United States and other countries.

SafeCLEAN, SaniSponge, SensorSAFE, and Symphony Plus are trademarks of Follett LLC.

Follett is a registered trademarks of Follett LLC, registered in US.



801 Church Lane • Easton, PA 18040, USA
Toll free (877) 612-5086 • +1 (610) 252-7301
www.follettice.com

