

FZRVAC20/25 – LB

Order parts online
www.follettice.com

Installation, Operation and Service Manual

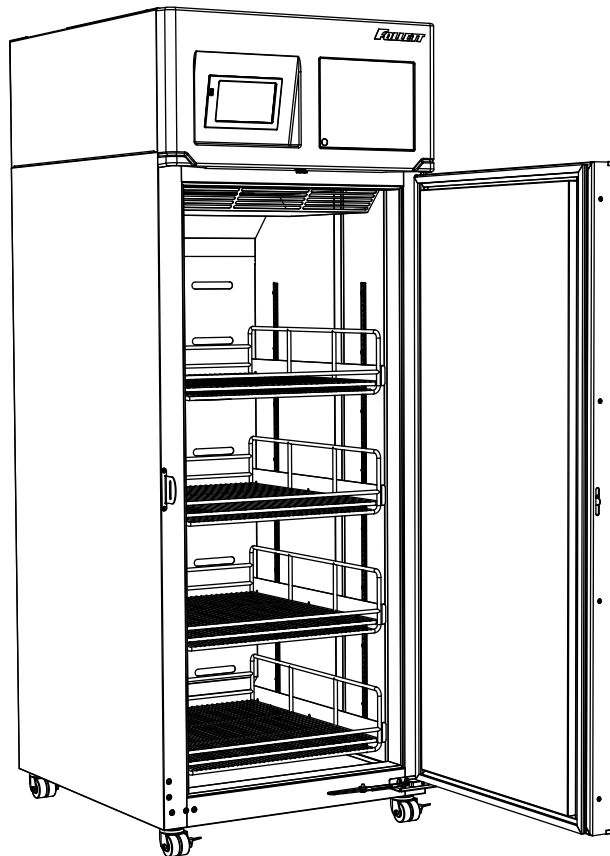

**Following installation, please forward this manual
to the appropriate operations person.**

 **CAUTION!**

- Do not tilt any unit further than 30° off vertical during uncrating or installation.
 - If the equipment is not transported vertically, a period of at least 24 hours must be allowed before starting. The equipment must be transported and handled exclusively in upright position. This is required to avoid contamination of the refrigerant with compressor oil. Contamination could result in valve and heat exchanger coil failure, problems starting the electric motor, or the risk of gas leak. The manufacturer is not responsible for any problems due to transport executed in conditions other than those specified.
- Controller board is susceptible to electrostatic discharge. Extreme care should be exercised by using a grounding strap when handling and installing control board.
- Refrigeration module area contains mechanical, moving parts. Keep hands and arms clear of this area at all times. If access to this area is required, power to unit must be disconnected first.

Contents

Welcome to Follett	4
Before you begin.	4
Ambients.	4
Clearances	4
Electrical specifications	5
Refrigeration specifications	5
Detail drawing.	5
Installation.	6
Adjust self-closing door.	6
Install shelves and power up	7
Fill product bottle.	7
Power the Unit.	7
Third-party probe wire routing (if desired)	8
Controller Operation	9
Use and care of the LCD touchscreen	9
Cleaning	20
Interior cleaning	20
Exterior cleaning.	20
Annual cleaning	21
Refrigeration System.	21
Defrosting	21
Service - System Controls	22
Controller Operation	22
Sensor Readings/Temperature Display	22
Fascia Heater	22
Facade removal	23
Controller replacement	23
Reversing the door swing (requires a new door)	24
Door gasket replacement	24
Slide-out unit cooler	24
Refrigeration specifications	25
Wiring diagram - Embraco CRS.	26
Replacement parts	27
Cabinet	27
Unit cooler - Embraco CRS (Black Evaporator Cover).	28
Facade	30
Door assembly	32

Welcome to Follett

Follett equipment enjoys a well-deserved reputation for excellent performance, long-term reliability and outstanding after-the-sale support. To ensure that this product delivers that same degree of service, we ask that you take a moment to review this manual before beginning the installation. Should you have any questions or require technical help at any point, please call our technical service group at (877) 612-5086 or +1 (610) 252-7301.

Before you begin

After uncrating and removing all packing material, inspect the equipment for concealed shipping damage. If damage is found, notify the shipper immediately and contact Follett Corporation so that we can help in the filing of a claim, if necessary.

Check your paperwork to determine which configuration you have. Follett configuration numbers are designed to provide information about the type of freezer you are receiving. Following is an explanation of the different item numbers.

	FZRVAC20-LB	FZRVAC25-LB
Capacity	19.7 cu ft (558 L)	24.6 cu ft (697 L)
Usable space	12.8 cu ft (0.36 cu meters)	16.4 cu ft (0.46 cu meters)
Storage system	(4) epoxy-coated shelves	(4) epoxy-coated shelves
Exterior width	29.75" (76cm)	29.75" (76cm)
Exterior depth	29" (74cm)	35" (89cm)
Exterior depth with handles	30.5" (78cm)	36.5" (93cm)
Exterior height with casters	79.5" (202cm)	79.5" (202cm)
Interior dimensions (W x D x H)	24" x 22.5" x 56" (61cm x 58cm x 143cm)	24" x 28.5" x 56" (61cm x 73cm x 143cm)
Crated weight	438 lb (199 kg)	467 lb (212 kg)
Max. heat rejection	2400 BTU/hr	2400 BTU/hr

Standard features – all models	
Door	Solid, insulated, stainless steel
Door handle	ADA-compliant, full length handle with integral lock
Interior/exterior material	Heavy-duty, corrosion resistant stainless steel
Casters	(4) dual-wheel swiveling casters with toe locks
Insulation	2.75" (7 cm) thick, CFC-free foam insulation throughout
Air circulation system	Ducted air through back plenum openings (12 - LB) with front face return
Temperature probe	Stainless steel RTD (resistance temperature detectors). One at top on all models.

Ambients

Intended for indoor use where ambient temperature does not exceed 86 F (30 C) and ambient relative humidity does not exceed 60% RH.

Clearances

To ensure proper ventilation of the refrigeration system, the following clearances are required:

- 16 inches (41 cm) above the freezer
- 2 inches (5 cm) behind freezer
- 9 inches (23 cm) on the left side. If the ambient is <86 F (30 C), no side clearance is required.

Electrical specifications

- 120 V, 60 Hz, 1 phase
- Full load amps: 12FLA, 67 LRA compressor
- Minimum circuit ampacity: 25A with max 60 ft. (18.2 m) wire run between receptacle and breaker using minimum 12 AWG
- Minimum voltage at compressor terminals: 97 Vac when energized
- **Maximum size of branch circuit overcurrent device: 20A dedicated circuit**

Refrigeration specifications

- Refrigerant R404a, 10.6 oz (300 g)
- Compressor amperage: RLA - 9.8A, LRA - 67A
- Compressor winding resistances: C-S (3.5 Ω), C-R (0.7 Ω), S-R (4.2 Ω)
- Evaporator fan motor: RLA - 0.28A, 38 Ω or 95 Ω
- Condenser fan motor: RLA - 0.58A, 35 Ω

Note: Do not charge the system by pressures.

Detail drawing

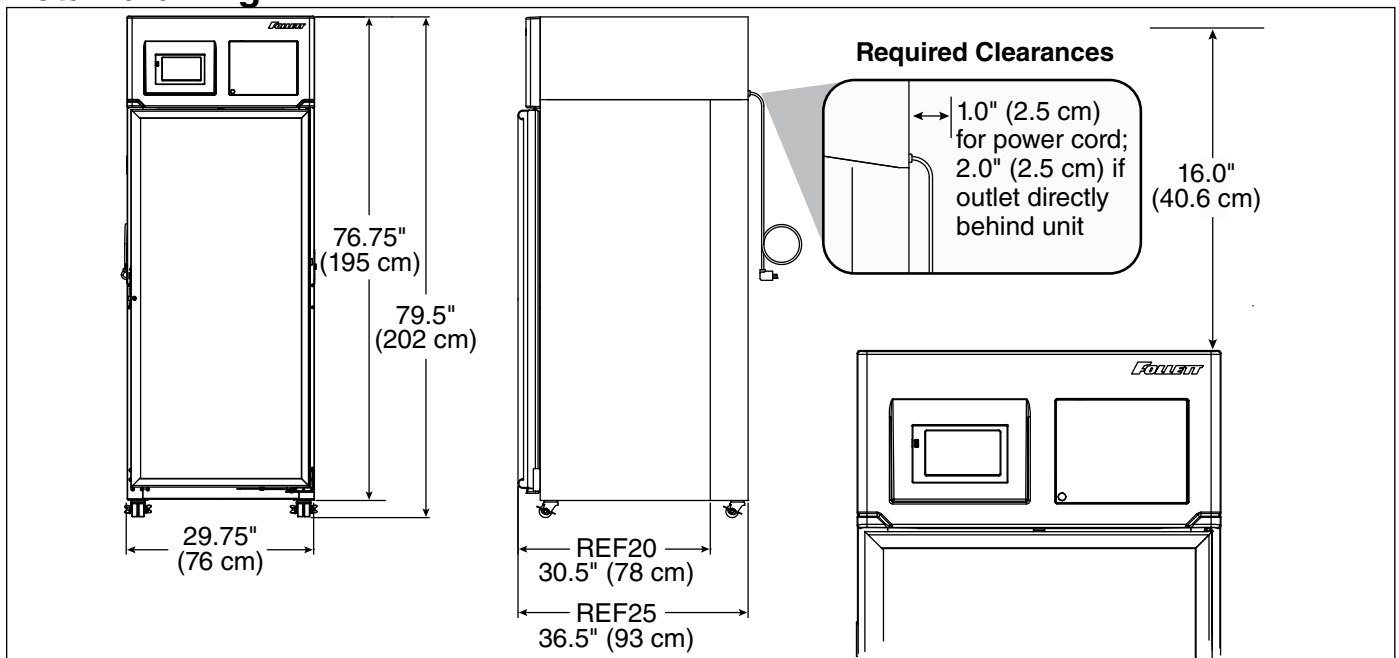

Installation

⚠ DANGER	
	<ul style="list-style-type: none">• Do not tilt any unit further than 30° off vertical during uncrating or installation• Refrigeration module area contains mechanical, moving parts. Keep hands and arms clear of this area at all times. If access to this area is required, power to unit must be disconnected first.

1. Remove key taped to side of freezer cabinet and unlock door.
2. Remove casters from box packed inside freezer.
Note: California facilities requiring wall and floor anchors – refer to wall anchor kit instructions (#00938241) packed with seismic kit before proceeding with caster installation.
3. Unbolt freezer from pallet.
4. Rotate freezer on pallet to install casters (**Fig. 1.1**).
5. Install casters by hand one at a time using channel locks to tighten, until caster meets against the bottom of cabinet (**Fig. 1.2**).
6. Peel protective film from exterior walls of stainless cabinet.

Adjust self-closing door

1. Roll freezer to desired location and lock as many casters as possible (**Fig 2.1**).
2. If the door appears to be sagging, remove the philips screw (**Fig. 2.2**) holding the Hold Open Bracket to the Hinge Bracket to gain access to the Sag Adjustment Screw (**Fig. 2.3**). Turn the Sag Adjustment Screw to align the door squarely with the freezer cabinet. When finished, reinstall the Hold Open Bracket.
3. Check door for closing tension and adjust if necessary. To check closing tension, open door 1" and turn screw (**Fig. 2.4**) counterclockwise until you achieve positive close. (Light will go out) Then, turn another half turn counterclockwise.

Fig. 1

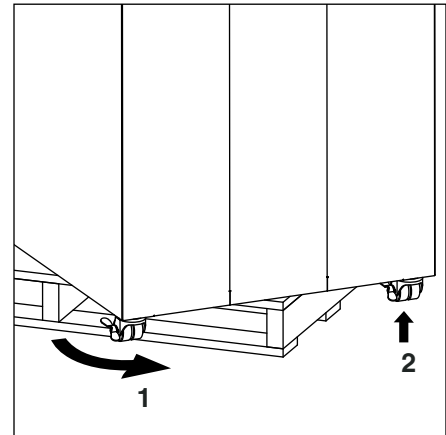
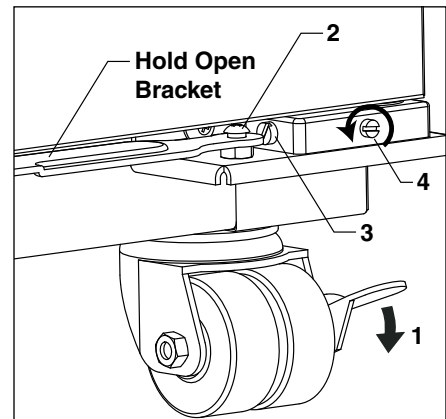

Fig. 2



Install shelves and power up

1. If freezer is equipped with shelves, remove bag containing shelves supports and position them in desired locations on each pilaster and insert shelves (**Fig. 3**).
2. Plug freezer into a 120 V 60 Hz 15A dedicated outlet.

Fig. 3

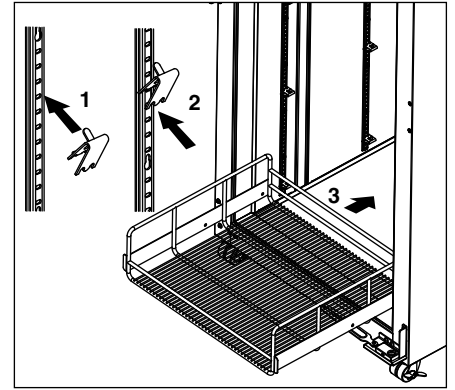

Fill product bottle

1. Remove probe and cap from the top bottle and fill with glycerine supplied with unit (e.g., 60% glycerine and 40% water) (**Fig. 4**). Replace cap and reinsert probe sensor.

Fig. 4

ATTENTION INSTALLER

- It is imperative that the top/bottom probe bottle be filled with a solution that your facility uses to ensure proper operation of unit.
- Units are equipped with a third-party monitor installation port. Customers are required to refer to CDC Vaccine and Handling Toolkit (cdc.gov) for proper placement of the probe within the cabinet to ensure proper performance.
- NSF 456 requires the temperature display probe (P4-RTD1 in REF 12, REF20/25, FZR20/25, and REF45 models) to be replaced or recalibrated. Follett recommends replacement/recalibration 12 months from the original date of calibration on the Certificate of Traceability supplied with your equipment at the time of purchase. Recalibration or purchasing a new calibrated probe is not covered by the original equipment warranty. To purchase a new Probe with Certificate of Traceability, please contact our Parts Department @ 1-877-612-5086 or partsales@follettice.com

2. Adhere supplied probe wire clips (x4, packaged with manual) to inside wall leading to the probe bottle.
3. Route probe wire into clips and close the clips.

Power the Unit

1. Press lower left corner of front facade door to access power switch inside (**Fig. 5.1**).

Fig. 5

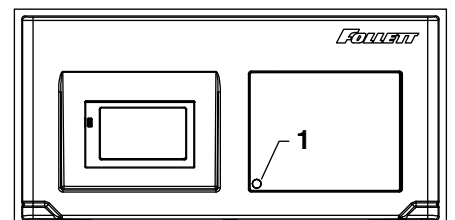

2. Press power switch to turn unit on (**Fig. 6.1**).
3. Connect wiring harness to back-up battery pack.

Fig. 6

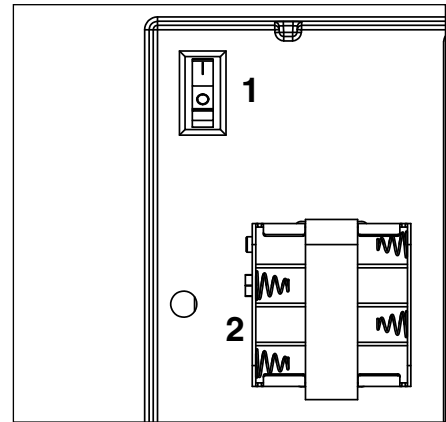

Third-party probe wire routing (if desired)

1. Use a drill or awl to prepare an opening to allow routing of the third-party probe into the cabinet at the location shown (**Fig. 7**).
2. Use permagum sealant to cover hole opening after probe is routed into cabinet.

Fig. 7 (top view)

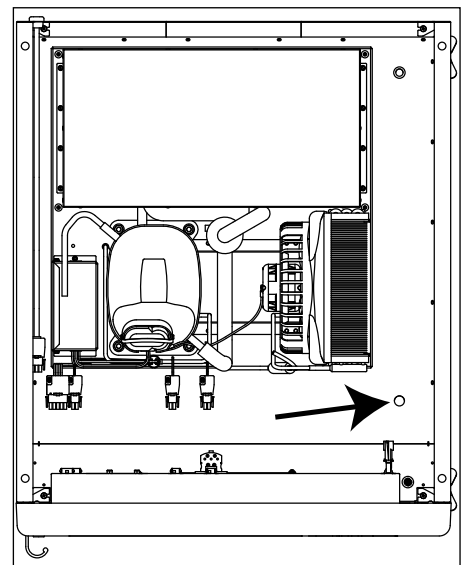

3. Remove front left and right return louver screws to uncover access port (**Fig. 8**).
4. Route probe wire down either side channel in cabinet.
5. Use permagum to seal around probe wire access hole.
6. Reinstall louver screws.

Fig. 8

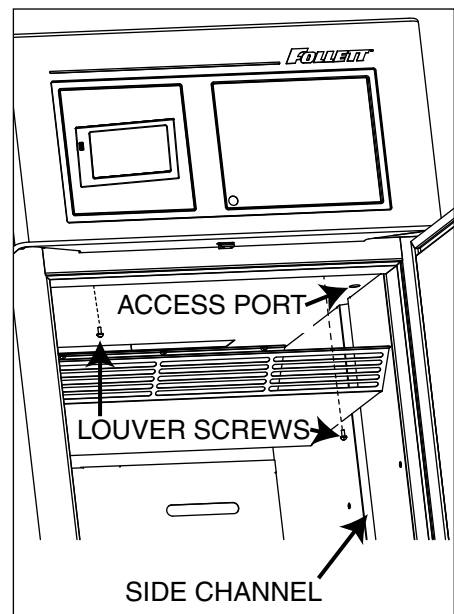

Controller Operation

Use and care of the LCD touchscreen

















The LCD touchscreen utilizes capacitive touch technology. This will allow you to engage the functionality by touching the screen with your fingers, even while you are wearing latex or cotton gloves. Functionality will not engage by touching with an inanimate object, such as a pen or stylus.

- To preserve optimal touch sensitivity, keep the screen clean by using a clean, dry cotton cloth.
- Do not expose the screen to liquids or excessive dust, heat or humidity.

Control function icons and navigation buttons engage functionality of the user interface. Status indicators alert the user to a change of status.

Home screen

The Home Screen consists of three primary information areas: the temperature display, control function display zone and system status display.

Control Functions	System Status	Functions and Settings
 Settings	 Compressor is running	 USB download available (downloading when blinking)
 Alarming	 Evaporator fan is running	 Refrigeration set points
 Light	 Door is open	 Sleep functions
 Information log	 Defrost cycle is in process	 Centigrade to Fahrenheit
 Help		 Probe set points
		 Alarming functions
		 Alarm mute
		 Reset

- Product temperature is displayed in the upper right corner.
- Current selected display probe above temperature readout.
- Primary control function icons are displayed in the lower left corner.
- System status icons will display in lower right corner to indicate a condition has been activated.

High and low temperature display

From the home screen touch the temperature display in the upper right corner. The high/low temperatures will appear below the temperature display. To the left of the high/low temperature, a time and date stamp will be displayed.

View min/max temperature log

1. Press the Temperature Display in the upper right hand corner of the display
 - Will initially display MIN/MAX temperature of Top probe.
2. Press a second time to prompt a reset Top probe MIN/MAX.
3. Press a third time to display HIGH/LOW alarm settings.

Fig. 9



Fig. 10



Fig. 11



Reset the high and low temperatures

Touch the temperature display a second time and the reset function ⓘ will appear under the high and low temperature. Touch the reset icon and a yellow message box will appear. Press ✓ to confirm reset or ✗ to cancel.

Alarm set point display

From the home screen touch the temperature display three times. The High and low alarm set point will appear under the temperature.

VAC models have the alarms factory preset to -15 C (5 F) and -46 C (-50 F).

Help

- Help is available at any time by touching the ⓘ icon at the bottom of the screen.
- Help is screen-specific; touching the ⓘ icon will display an explanation of the functionality and use of the screen you are currently viewing.
- Touch ✓ to exit help screen.

Settings ⚙️

- Refrigeration Set Point ❄️
 - Touch the number displayed in the box to the right of the Set point label and use the keypad or **UP** and **DOWN** arrows to select product temperature. Press ✓ to accept or ✗ to cancel.
- Sleep Temperature Display 🌙
 - Toggle **ON** to hide the temperature reading immediately on the home screen.
- Set the Sleep Delay 🌙
 - To automatically hide the temperature after 0-600 seconds of inactivity, touch the box to the right of the delay (0-600) box. Use keypad or **UP** and **DOWN** arrows to select from 0-600.
- Temperature 🌡️
 - Toggle between **F** and **C** to select Fahrenheit or Celsius.
- Brightness 💡
 - Touch the number displayed in the box to the right of the Brightness 💡 icon and use the keypad or **UP** and **DOWN** arrows to select from 1-10. Press ✓ to accept or ✗ to cancel.

System Information

- Touch the System Info icon ⓘ to display the model number, unit serial number and software version. Touch the checkbox icon ✓ in the lower right corner of the box to clear.

Fig. 12



Fig. 13

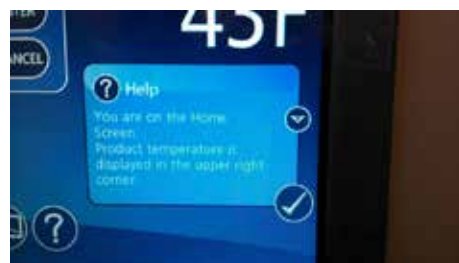

Fig. 14



Fig. 15



Fig. 16



Alarm or Alert Notifications





- If an alarm or event condition is detected and an alarm is engaged, an alert notification will appear in the left center of the screen with an explanation of the alert condition and a checkbox  at the bottom right of the alert box.
- No further action can be taken on the User Interface until the alert condition is acknowledged and cleared by touching the checkbox .
- Mute 
 - Touch the  icon to mute audible alarm for 10 minutes.

Fig. 17



High/Low Alarm

- This unit is equipped with a High and Low Temperature alarm that will give an audible and visual alarm immediately after the top probe falls out of range. The alarm will reappear every 10 minutes until the condition falls back into range.

Door Switch

- This unit is equipped with a door switch that is located in the façade, and a magnet located on the top of the door. With the door closed, the switch reads closed. When the door is opened, the evaporator fans becomes de-energized.

Door Alarm

- This unit is equipped with a door ajar alarm that is factory set for 1 minute. In the event the door switch reads open for longer than 60 seconds (default) an audible and visual alarm will occur. The alarm will clear when the door is closed. The door alarm activation time can be changed from 0-600 seconds in the Advanced Settings Menu under Door Open Alarm Delay.

Power Alarm

- This unit is equipped with a Power Alarm that will sound if the unit loses power for more than five minutes. The Power Loss Alarm box will display every five minutes, then the screen will sleep. An audible alarm will sound every 30 seconds during the power failure. An alarm box will be displayed when power is restored. The event log will record the exact time and date of the power loss and when the power was restored.

Start-up alarm delay

This unit has a 120 minute time delay between when the unit is energized to when the temperature alarms become active. This delay can be changed in parameters in the controller under **Alarm Startup Delay**.

Setting Alarms









- Alarming Settings control the conditions and timing of event and alarm conditions that result in audible and/or visual alerts.
- To change the high alarm set point, touch the number displayed in the box to the right of the  icon and use the keypad or **UP** and **DOWN** arrows to select an alarm value. Press  to accept or  to cancel.
- To change the low alarm set point, touch the number displayed in the box to the right of the  icon and use the keypad or **UP** and **DOWN** arrows to select alarm value. Press  to accept or  to cancel.
- Audible Alarm 
 - Toggle between **ON** and **OFF** to engage and disengage the audible alarm function.
- Mute 
 - Touch the  icon to mute audible alarm for 10 minutes.

Fig. 18



Alarming Contacts

This unit is equipped with dry contacts that may be connected to a 3rd party monitoring system. The contacts are located on the back of the facade. Touchscreen units utilize Alarm 1. Each set of dry contacts has a Common, a Normally Open and a Normally Closed connection point. By default, Alarm Relay 1 is set to activate with any of the following alarms: Alarm 1 High temp, Alarm 1 Low temp, Door Open Alarm, and Power Loss Alarm.

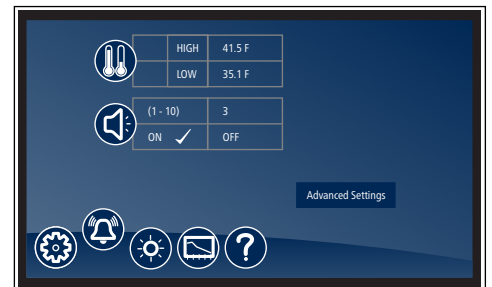
Refer to the wiring diagram in this document for more information.

Fig. 19

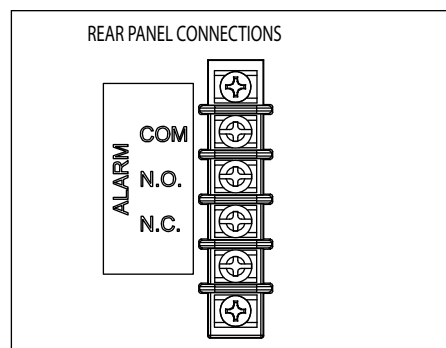

Probe calibration

NSF 456 requires the temperature display probe (P4-RTD1 in REF 12, REF 20/25, FZR 20/25, and REF 45 models) to be replaced or recalibrated. Follett recommends replacement/recalibration 12 months from the original date of calibration on the Certificate of Traceability supplied with your equipment at the time of purchase. Recalibration or purchasing a new calibrated probe is not covered by the original equipment warranty. To purchase a new Probe with Certificate of Traceability, please contact our Parts Department @ 1-877-612-5086 or partsales@follettice.com

The temperature probes can be offset -9.9 to $+9.9$ in the Advanced Menu settings to deliver a more precise temperature reading.

1. Select Settings
2. Select Advanced settings and enter code 1,1,1,1. Confirm with Check mark
3. Using the DOWN arrow, scroll through Advanced Settings to Calibrate screen and select Calibrate
4. Place desired probe (P1-control, P2-Defrost, P4-Top probe) in an ice bath and allow 3-5 minutes for temperature stabilization.
5. Press "Offset" and use the UP/DOWN arrows to offset the probe reading to the proper value.

Note: In the event of a factory reset, the offset value will return to 0.

Screen saver

The screen saver will replace the home screen and display a blank screen, time and date, or the temperature. When the screen is touched or the unit has an alarm or event, it will return to the home screen. The screen saver can be changed in the advanced setting.

Screen saver function: blank, time and date, or temperature.

Screen saver time (sec): 0—600 seconds between the last touch of the screen to the activation of the screen saver.

Information Logs

- All available graphs, data logs and event logs are accessed through the Information Logs function. The home screen in the Information Logs section displays the product (P4) temperature graph with one week's data. Date and time information is displayed on the horizontal axis.
- This unit comes factory set to display only the product temperature (P4) on the graph. All of the probes can be viewed on the graph if desired. Probes can be added to the graph through the advanced setting under DATALOG. P1 and P2 can be added by selecting the probe and changing the parameter from No to Yes. The selected probe will now display on the graph.
 - P1 control, P2 defrost, P4/RTD1 (Top Probe)
- Zoom in (+) or Zoom out (-) on an event/temperature on the home screen will change the time scale.
- Using the left and right arrows below the graph will scroll the graph. All the stored temperature data on the graph is viewable.
- Temperature Log – to display a chronological listing of logged temperatures (latest logged temperature will display first), touch the **Temperature Log** label to the left of the screen. Use the **UP** and **DOWN** arrows to the right of the screen to scroll through the logged temperatures.
- Event Log – to display a chronological listing of events (including errors, alarms and alerts), touch the **Event Log** label to the left of the screen. Use the **UP** and **DOWN** arrows to the right of the screen to scroll through the logged temperatures.

Fig. 20



Fig. 21



Data Storage

- Data can be captured different ways. The factory default is for the data to overwrite itself when the memory is full. This can be changed in the advanced setting under **Data storage overwrite**. When this parameter is set to **No**, the system will display an alert when the memory is 75% full. To clear the alert the data must be downloaded.

Data duration alarm

- A reminder can be set to download the data in the **Data duration alarm** in the advanced setting. The data duration can be set from **1 to 180 days**. If the data duration alarm is used, then the **Alarm on data full** parameter in the advanced setting must also be set to **Yes**.

Downloading data

- The touchscreen has the capability of downloading the temperature data and event log via a USB port on the left side of the user interface. The file is a CSV format and is suitable for import directly into Microsoft Excel.

1. Insert the storage device in the USB slot located to the left of the Touchscreen.
2. Select the Graph icon along the bottom of the Touchscreen.
3. Select the USB icon in the lower right hand corner.
4. A yellow alert box with **downloading data** will appear.
5. Press to accept or to cancel.
6. After the unit is done downloading a second yellow alert box will appear asking if you want to **Erase log**.
7. Press to accept or to cancel.

Note: If you chose to erase the data, the data duration timer and the data full alarm will reset. It will also erase the information that is stored on the graph.

One of the two files below will be downloaded depending on which screen is being viewed:

EL XXXX YY - Event Log

TL XXX YY - Temperature Log

XXXX = last 4 digits of serial number

YY = 0-99 number of downloaded file

Data download reminder and data full alarm

- If you plan or are required to download data for a certain time period, you can set a **download data reminder** on the Performance Plus unit. Download data reminder can be found in the advanced setting under **Data duration** and can be set from **1 to 180 days**.







Fig. 23













Fig. 24



Changing and Adding the User Codes

1. Touch Settings  icon.
1. Touch **Advanced Settings**, enter your 4-digit user access code (factory default is 1 1 1 1) in the keypad that appears, and touch the checkmark icon  to access advanced settings screens.
2. Time and date will be displayed. Scroll using the **UP** and **DOWN** arrows until **Change Access Code** is displayed in the Display Setup screen.
3. Touch **Change Access Code** and enter the master code [ENTER]. (By default, the master code is 1 2 3 4 5 6.)
4. Touch the screen to the right of the user code 2 to 40 to overwrite or add the user code.
5. Enter the new code. Press  to accept or  to cancel.
6. Enter the new code again. Press  to accept or  to cancel.
7. Press **DONE** when finished entering access codes.

Time and Date

- To set time and date, press the Settings  icon.
- To display options, touch **Advanced Settings**, enter your 4-digit user access code in the keypad that appears, and touch the checkmark icon  to access advanced settings screens (factory default is 1111).
- Time: touch displayed time and use the keypad to enter the time. Press  to accept or  to cancel.
- AM/PM: touch displayed value to toggle between AM and PM.
- Month: touch number displayed and use the keypad to enter the month. Press  to accept or  to cancel.
- Day: touch number displayed and use the keypad to enter the day. Press  to accept or  to cancel.
- Year: touch number displayed and use the keypad to enter the year. Press  to accept or  to cancel.

Advanced Settings

- Touch **Advanced Settings**, enter your 4-digit user access code in the keypad that appears, and touch the checkmark icon  to access advanced settings screens (factory default is 1111).

Fig. 25



Fig. 26



Fig. 27

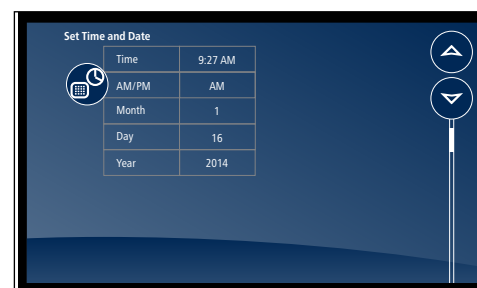

Advanced Setting - touchscreen

Parameter	Default Value	Range	Description
Set Time and Date			
Time	7:45	0-12	Holds Hour
AM/PM	AM	AM, PM	Holds AM/PM
Month	12	1-12	Month
Day	16	1-31	Day
Year	2013	2010-2099	Year
System Information			
Serial Number	E12345	—	—
MC Version	33	—	MC version
EMC version	2	—	EMC version
UI version	17	—	UI version
Keypad version	2	—	Keypad version
Display Setup			
Beeper Function	ALL	Off, All, dr, Alr, Err	Controls the audible beeper function on the controller. Off (all off), All (all on), Door (dr), Alarm (Alr), Error (Err).
Beeper Volume	5	0-10	Beeper.
Button Clicks	Yes	Yes, No	Sets if a beep should sound each time a button is pressed.
Display Probe	RTD1 (P4)	Control (P1), Defrost (P2), P4	The probe to display on controller.
Resolution	Int	Dec	Integer or decimal
Sleep Function	Yes	Yes, No	Sleep function will blank the screen after 0-600 seconds of non-use.
Sleep Timer	0 seconds	0-600 seconds	Amount of time before the screen blanks automatically.
Screen Saver Function	Temperature	Blank, temperature, date/time	Screen saver function will hide the home screen. It will display a blank screen, temperature, or time and date.
Screen Saver Timer	0 seconds	0-600 seconds	Amount of Time before the screen saver initiates.
Change Keypad Access Code	Change	—	Allows entry/editing of keypad access codes. Password required.
Control Setup (REFVAC/FZRVAC)			
User Set Point	LB = -11 F (-23.9 C)	LSP-USP	The temperature setpoint that the user adjusts.
Differential	4.4 C (7.9 F)	1-60 degrees	Defines the difference between the cut-in and cut-out temperatures.
Upper Setpoint	0 F (-17.8 C)	—	Upper range of user-adjustable setpoint.
Lower Setpoint	-35 F (-37.2 C)	—	Lower range of user-adjustable setpoint.
Lock Setpoint Adjustment	Unlocked	Unlocked, locked	Locks the setpoint C/F, and alarm high/alarm low against accidental changes.
Import Parameters	No USB drive	No USB, import parameters	Import parameters from a USB port.
Export Parameters	No USB drive	No USB, export parameters	Export parameters from a USB port.
Alarm Setup			
Alarm 1 Delay	0 minute	0-60 minutes	Alarm1 delay before sounding.
Alarm 1 Function	R1	No, R1, R2, disable	Defines the action when Alarm 1 is activated. None (No), Relay 1 (R1), Relay 2 (R2), Display (disable).
Alarm 1 High Temp	-15 C (5 F)	User Set Point to 250	High temperature to activate Alarm 1.

Parameter	Default Value	Range	Description
Alarm 1 Low Temp	-46 C (-50 F)	-50 - User Set Point	Low temperature to activate Alarm 1.
Alarm 1 Probe	P4	Control (P1), Defrost (P2), P4	Probe for Alarm 1.
Alarm 1 Reset	1	0-10	Temperature difference to reset Alarm 1.
Alarm 2 Set up			
Alarm2 Delay	1	0-60 minutes	Alarm2 delay before sounding
Alarm2 Function	Disable	No, R1 relay, R2 relay, Disable	Defines the action when Alarm2 is activated.
Alarm2 High Temp	49 C (120 F)	User Set Point 250	High temperature to activate alarm 2.
Alarm2 Low Temp	-46 C (-50 F)	-50 - User Set Point	Low temperature to activate alarm 2.
Alarm2 Probe	P4	Control (P1), Defrost (P2), P4	Probe for Alarm 2.
Alarm2 Reset	1 degrees	0-10 degrees	Temperature difference to reset alarm 2.
Alarm 3 Set up			
Alarm3 Delay	1	0-60 minutes	Alarm3 delay before sounding
Alarm3 Function	Disable	No, R1 relay, R2 relay, Disable	Defines the action when Alarm3 is activated.
Alarm3 High Temp	49 C (120 F)	User Set Point 250	High temperature to activate alarm 3.
Alarm3 Low Temp	-46 C (-50 F)	-50 - User Set Point	Low temperature to activate alarm 3.
Alarm3 Probe	P4	Control (P1), Defrost (P2), P4	Probe for Alarm 3.
Alarm3 Reset	1 degrees	0-10 degrees	Temperature difference to reset alarm 3.
General Alarm Reset			
Alarm Ringback	10 minutes	0-120 minutes	Defines the time delay until the alarm will resound.
Alarm Remote Reset	No	On, I1, I2, I3, I4	Determines if the alarms can be silenced with a remote input from I1, I2, I3 or I4
Alarm Startup Delay	120 minutes	0-180 minutes	Defines the alarm delay during startup.
Alarm Silencing	Yes	Yes, No	Determines if the alarms can be silenced or not.
Maintain Alarm	Yes	Yes, No	Determines if the alarm(1-3) should be maintained if the temperatures fall back into range.
Door Control			
Door Open Alarm	Yes	Yes, No	Sound beeper when door alarm activated.
Door Open Alarm Delay	60 seconds	0 - 300 seconds	Door open alarm delay.
Door Open Relay	Disable	No, R1 relay, R2 relay, Disable	Alarm Relay to activate when door open alarm activated.
Door Fan control	Yes	Yes, No	Defines if the evap fan should shut off when the door is open.
Door compressor time	60 seconds	0-180 Seconds	Defines the time to shut off the compressor after the door is open. 0=ignore
Light control			
Turn light on/off with door	Yes	Yes, No	Turn light on/off with door openings.
Light off timer	120 seconds	0-600 Seconds	Turn off the light after XX seconds
Power Alarm			
Power Alarm	Yes	Yes, No	Defines if an alarm should sound if power is lost.

Parameter	Default Value	Range	Description
Power Alarm Relay	Yes	Yes, No	Defines if relay should open/close on power alarm.
Power Alarm Timer	5 minutes	0 - 120 minutes	Delay before sounding the power alarm.
Battery Level			Battery Level
Data Storage	Yes	Yes, No	Overwrite circular data?
Data Full Alarm	No	Yes, No	Alarm when data memory is full?
Data log			
Sample Rate	15 minutes	0 - 360 minutes	minutes between data sampling. 0=Off
Data Duration			
Data Storage	Yes	Yes, No	Overwrite circular data?
Data Full Alarm	No	Yes, No	Alarm when data memory is full?
Track Events	Yes	Yes, No	Track events with log
P1 Datalog	No	Yes, No	Log P1 to event log
P2 Datalog	No	Yes, No	Log P2 to event log
P4 Datalog	Yes	Yes, No	Log P4 to event log
Defrost			
Manual Defrost	No	Yes, No	Force the unit into a defrost
Defrost Control	Power on	"Power on, manual only, disable, time of day, compressor on time"	Defines tactic for initiating a defrost
Defrost Type	Heater	Heater,Evaporator	Type of defrost (forced heat or fan only)
Defrost Termination Tactic	Temperature	time, temperature	Defrost end routine
Defrost Timer	6 hours	0-720 hours	Hours between defrost cycles
Defrost Termination Temp	5 C (41 F)	0 to 66 C (32 to 150 F)	When set to temperature, defines temp.
Defrost Duration (mins)	30 minutes	0-60 minutes	When dtr set to t (time), duration of defrost. Failsafe time when set to temp.
Evap Fan Defrost Delay	30 seconds	0-300 seconds	Time to delay starting of evap fan after restarting system. (ignored if dtp=Fan)
Drip Timer	120 seconds	0-300 seconds	delay at end of defrost cycle before starting system.
Evap Fan Restart	Temperature	Time , Temperature	Defines if the evap fan should restart on time or temp after compressor starts during the defrost routine. T=time, Tp=temp
Evap Fan Temp	-9 C (15 F)	-37 to 13 C (-35 to 55 F)	Temperature to restart evap fan, when EFr= temp.
Graphing			
X Axis Range (hrs)	168 hours	1-384 hours	Time span for x-axis
Y Axis Minimum	-1 C (30 F)	-46 to 121 C (-50 to 250 F)	Minimum temperature shown on graph
Y Axis Maximum	27 C (80 F)	-46 to 121 C (-50 to 250 F)	Maximum temperature shown on graph
Graph Show Alerts	No	Yes, No	Determines whether alerts are displayed on the graph
P1 Graph Display	N0	Yes, No	Determines whether to graph probe 1
P2 Graph Display	No	Yes, No	Determines whether to graph probe 2

Parameter	Default Value	Range	Description
P4 Graph Display	No	Yes, No	Determines whether to graph probe 4
Door Heater			
Door Heater	UR FZRVAC: Yes	Yes, No	Controls door heater output
Door Heater Off (mins)	UR FZRVAC: 5	0-100	Off time for door heater if dht=on
Door Heater On (mins)	UR FZRVAC: 15	0-100	On time for door heater if dht=on
Error control			
Probe Error	BPr	NO, BPr, R1 relay, R2 relay	Action to take when probe error detected
Control On Time (mins)	UR FZRVAC: 6	0.0 - 120.0 minutes	Compressor on time when control probe error (minutes)
Control Off Time (mins)	UR FZRVAC: 5	0.0 - 120.0 minutes	Compressor off time when control probe error
Calibration			
Calibrate probes			Calibrate probes through a second menu
Viewable			
Cut In			View cut in temperature
Cut Out			View cut out temperature
Probe 1 temp			View temperature of probe 1
Probe 2 temp			View temperature of probe 2
Probe 4 temp			View temperature of probe 4
Probe 5 temp			View temperature of probe 5
Power On Time (hrs)			View cumlitive hours that the unit was in service
Compressor cycles			The number of compressor starts
Compressor run time(hrs)			Veiw cumulative hours that the compressor was energized
Door open Cycles			The number of door opening
Door open time(hrs)			View cumulative hours that the door was open
Factory Reset			
Reset	No	No, Yes	Reset all parameters to factory reset

Cleaning

Use non chlorine-based cleaners. Cleaners containing chlorine can cause staining and pitting of the stainless steel.

Disconnect power to unit by turning the power switch off, located on the upper front facade panel, and removing the power cord from the receptacle.

Interior cleaning

Using a sponge or soft cloth, clean unit with a non-abrasive, non-chlorinated, all-purpose detergent. Note: The air plenum should be removed to clean it, as well as behind it (**Fig. 28, 29**). In addition, the shelves should be cleaned as well.

Exterior cleaning

Wipe stainless steel exterior with a soft cloth in the direction of grain as needed. Stainless steel polish may be used to enhance the finish of the unit. The glass door and exterior parts may be cleaned with a soft cloth, window cleaner or other non-abrasive cleaner.

Fig. 28

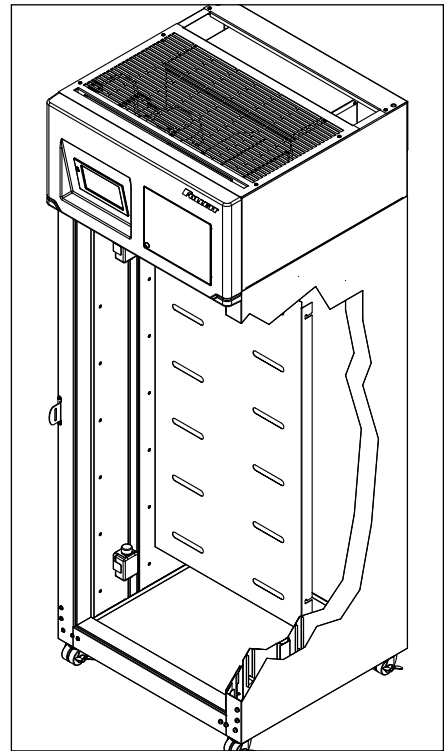
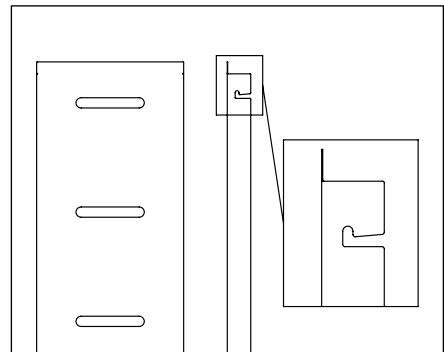

Fig. 29



Annual cleaning

Removal of dust and other particulates from air intake areas and the condenser is important for proper operation. Environments with large amounts of dust may require more frequent cleaning.

1. Disconnect power to unit by turning power switch off (located on upper front facade panel) and removing power cord from receptacle.
2. The condenser can be accessed from top for cleaning. The side panel in front of condenser may be completely removed for easier cleaning by disconnecting facade and removing upper side panel. See Face Removal for facade removal instructions.
3. Inspect drain pan for any debris or obstruction in condensate pan (**Fig. 30.1**).
4. Use a vacuum cleaner with brush attachment to clean condenser, compressor and related parts.
5. Reinstall upper side panel and facade if removed.

Fig. 30

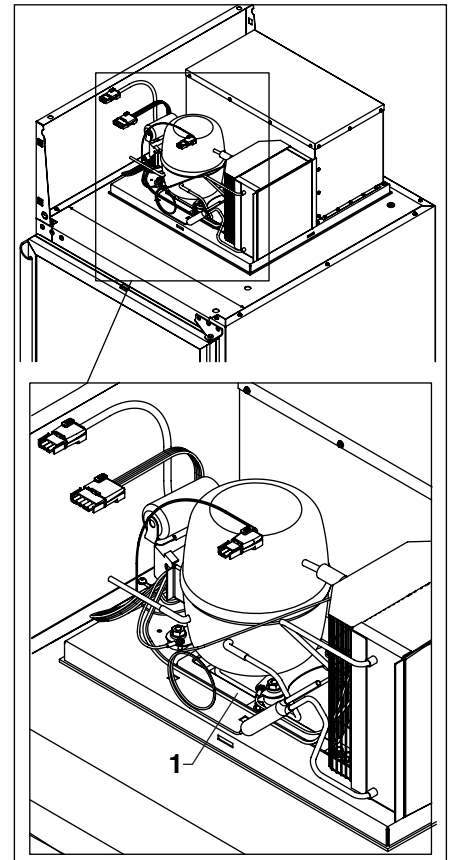

Refrigeration System

The FZRVC20/25 series refrigeration system is designed to give many years of trouble-free service. Except for routine cleaning of the air-cooled condenser and related parts, the refrigeration system requires no service or maintenance. The system uses a thermostatic expansion valve (TXV) metering device and is critically charged. Access fittings are not provided. Temporary piercing valves are required to work on the refrigeration system. Follett recommends that if hoses are ever connected to the refrigeration system for service, the refrigerant should be recovered, permanent access valves should be installed and the system evacuated, and recharged by weighing in the correct refrigerant charge (10.6 oz. (300g) R404a).

Note: Do not charge the system by pressures.

Defrosting

The FZRVC20/25 series upright freezers control frost accumulation on the evaporator through automatic timed defrost cycles. The evaporator defrosts automatically every 6 hours. The evaporator face mount heater, drain pan heater, and condensate drain line heater energize and any accumulated ice on the evaporator and evaporator drain pan melts and drains out the drain line to the condensate pan located under the compressor. Defrosting will display on the main screen above the product temperature button. Defrost terminates when either 30 minutes has elapsed or the evaporator temperature reading from the defrost probe (P2) reaches 5.0 C (41 F).

Service - System Controls

The temperature controller and evaporator probe (P1-control) indicate when the refrigeration system is required to turn on and off.

The refrigeration system removes heat from the cabinet and rejects it into the surrounding room air.

When the evaporator probe (P1-Control) reaches its predetermined cut-in value (Advanced settings, Viewable), the probe signals the controller to turn on the refrigeration system. The controller sends a 12VDC signal to the normally open compressor relay. The relay then closes, energizing the compressor and condenser fan.

When evaporator probe (P1-control) reaches its predetermined cut-out value (Advanced Settings-Viewable), the controller interrupts the 12VDC signal to the compressor relay, de-energizing the compressor and condenser fan. The evaporator fan runs continuously.

Controller Operation

The controller displays product temperature in degrees C (default) or F to 1 decimal point.

VAC Lab Models

The controller is pre-programmed to deliver approximately -23.9 C (-11 F) product temperature.

All set point operate with a 3.3 C (5.9 F) evaporator offset and a 4.4 C (7.9 F) differential. The set point, along with the differential, determine the cut-in and cut out points of the cooling system. For instance, a unit operating with a -23.9 C (-11 F) set point will cut-in at -20.7 C (-5.1 F) and cut-out at -25.1 C (-13 F) according to the P1 control probe located in the return air stream. Cut-in and Cut-out parameters are Viewable in the Advanced Settings Menu.

Sensor Readings/Temperature Display

The Touchscreen is defaulted to display the P4-Top probe which reads the solution temperature of your product simulation bottle. For ease of troubleshooting, the Touchscreen can be toggled to display the P1-control, P2 defrost). To toggle the display for your desired probe, Access Advanced Settings>Display Probe and select the desired probe.

Note: After service is complete it is recommended to restore the display to the P4-Top Probe.

Fascia Heater

Factory default for the fascia heater cycle is set to 75%, based on a 20 minute cycle (e.g. 75% = 5 minutes off, 15 minutes on).

Should the need arise, the door schedule can be changed in Advanced Menu>Door Heater.



Facade removal

The facade is removed by loosening the top left and right Phillips screws on the back of the facade to allow the securing clips to rotate away from the side panels. The facade can simply pull off of the front by pulling it out of the bayonet mounts that secure it to the upper left and right panels. If the facade will be completely removed, the electrical plugs should be disconnected. The ground wire should be removed from the top right grounding screw on the cabinet box, not from the facade (**Fig. 31.1**).

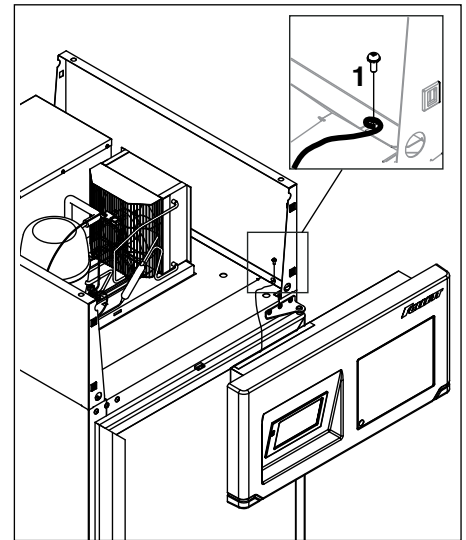
Fig. 31



Controller replacement

 CAUTION	
	<ul style="list-style-type: none">• Controller board is susceptible to electrostatic discharge. Extreme care should be exercised by using a grounding strap when handling and installing control board.

1. Turn off power to unit and unplug.
2. Disconnect electrical plugs and remove facade.
3. Remove screw securing ground screw to freezer cabinet (**Fig. 32.1**). Do not remove ground wire from facade.
4. Place facade face down on flat clean surface with bottom of facade facing you, and remove four screws attaching back panel to facade.
5. Lift and rotate back panel toward you.
6. Take precautions for proper grounding to reduce risk of electrostatic discharge (ESD) to the controller board.
7. Locate the 8 control board standoffs. (Picture needed)
8. Using Needle nose pliers, pinch the stand-off tabs and gently pull up on the control board to release.

Note: All wiring should remain connected to the original control board at this time.

9. Install replacement control board on existing stand-offs.

Note: Use supplied stand-offs to replace any that may have been damaged during control board removal.

Fig. 32

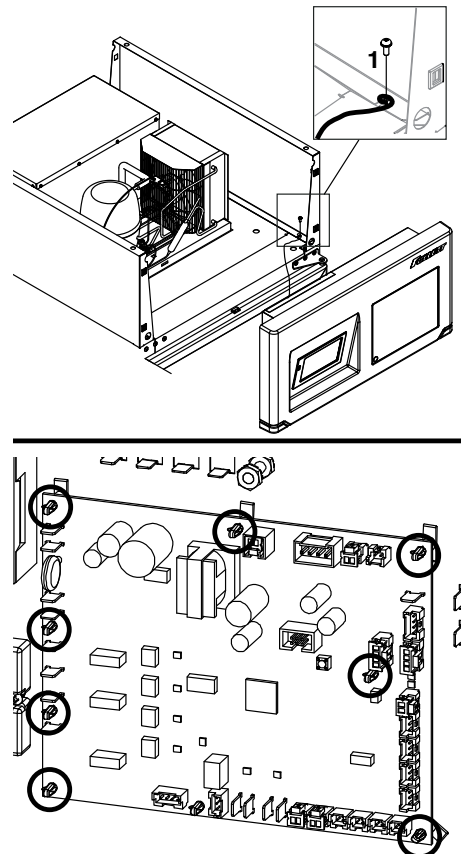

10. Removing one at a time, transfer wiring from the original control board to the replacement control board, ensuring each wire is secured at the same location it was removed from.
11. Flip façade cover back into position on façade and reinstall 4 screws.
12. Remount façade to bayonet mounts.
13. Reconnect ground wire to grounding location on cabinet
14. Reconnect all electrical and probe connections.
15. Plug in unit and power on, ensuring proper operation

Reversing the door swing (requires a new door)

FZRVAC20/25 units ship standard with a non heated right hinged door. To change to a left hinged configuration requires a new door.

Door gasket replacement

1. Remove existing gasket from mounting track (**Fig. 33**).
2. Verify mounting track is free of any remaining gasket material.
3. Align new gasket with mounting track and press firmly in place.
4. Open and close door, checking for proper gasket seal without pinching against freezer.

Fig. 33

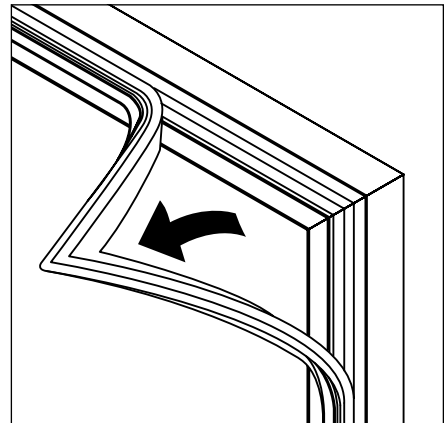

Slide-out unit cooler

Follett's slide-out refrigeration system allows technicians to remove the entire unit from the freezer top.

1. If necessary remove facade and upper side panels.
2. Remove four bolts securing unit cooler to freezer top (**Fig. 34**).
3. Gently lift off cooler.

Fig. 34

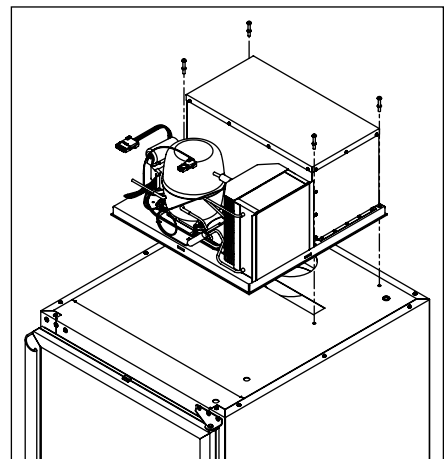

Refrigeration specifications

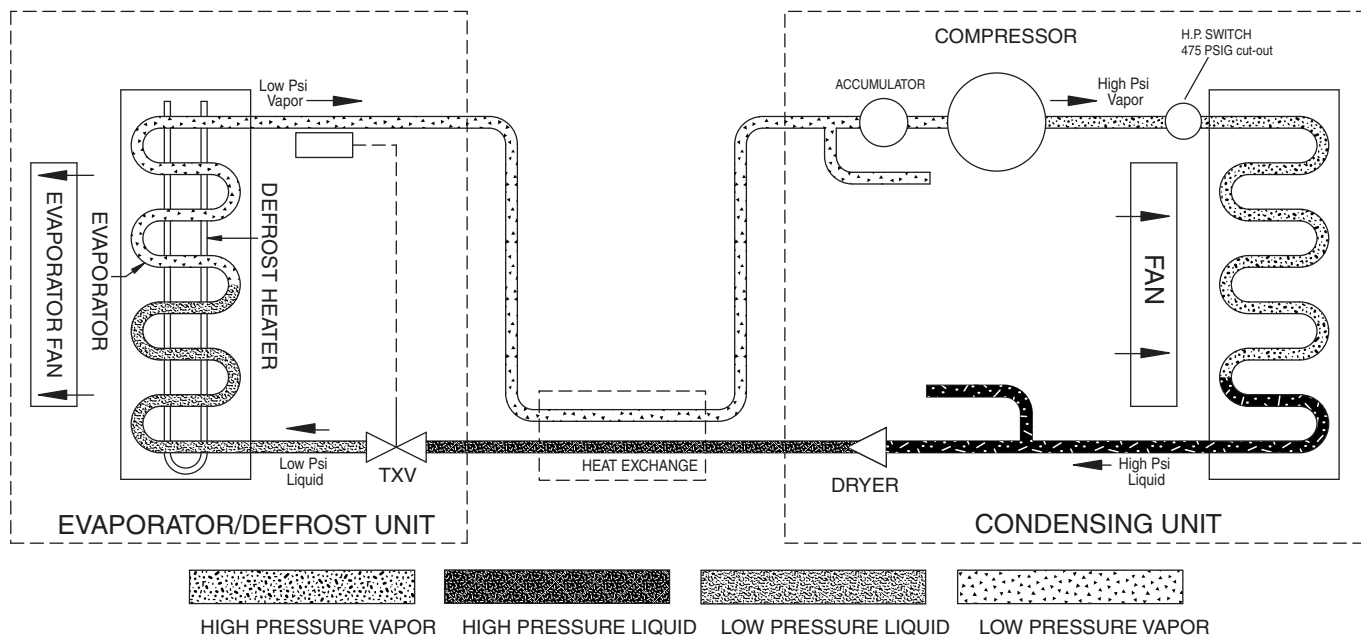

- Refrigerant R404a, 10.6 oz (300 g)
- Compressor amperage: RLA - 9.8A, LRA - 67A
- Compressor winding resistances: C-S (3.5Ω), C-R (0.7Ω), S-R (4.2Ω)
- Evaporator fan motor: RLA - 0.28A, 38Ω or 95Ω
- Condenser fan motor: RLA - 0.58A, 35Ω

Condenser Fan Motor Data:

RLA 0.58A
Ohm 35Ω

Defrost Heater Data:

Evaporator Heater: 400 W, 2.98A–4.0A, 31Ω–35Ω
 Drain Pan Heater: 85 W, 0.63A–0.86A, 148Ω–163Ω
 Drain Tube Heater: 15 W, 0.11A–0.15A, 909Ω-1005Ω
 Total in parallel: 3.88A–5.24A, 25Ω–28Ω

Fascia Heater Data: 70 W, 0.47A–0.65A, 196Ω–216Ω

Replacement parts

Cabinet

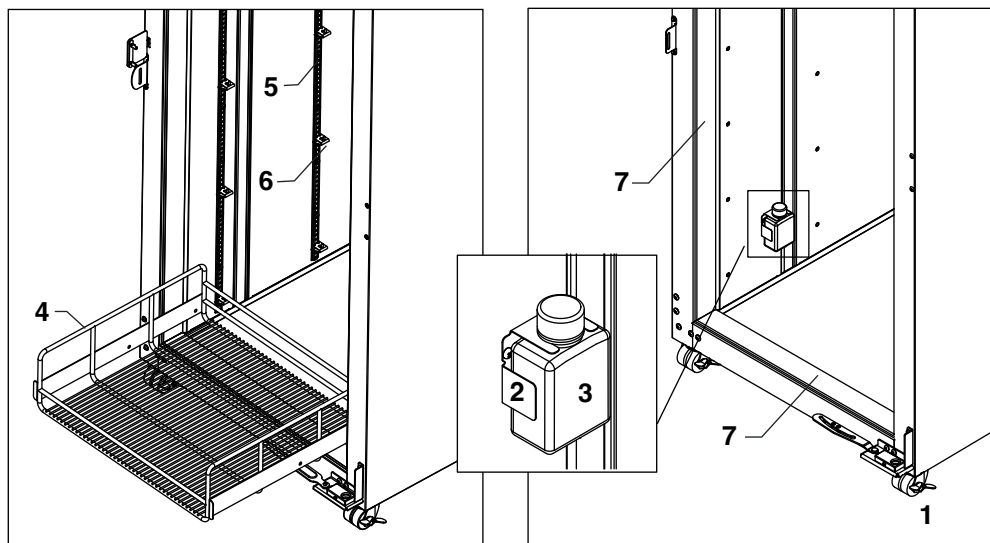

Reference	Description	Part #
1	Caster, swivel with brake	00187674
2	Bracket, bottle, 125ML	00171132
3	Bottle with gasket	01015817
4	Shelf, FZRVAC 25 (with supports)	01460708
4	Shelf, FZRVAC 20 (with supports)	01461268
5	Pilaster (with screws)	01015866
6	Shelf supports (qty. 1), 4 needed per shelf	00156240
7	Kit, fascia heater with thermal break covers	01015882
Not shown	Air panel, FZRVAC20/25 LB	01234558
Not shown	Temperature probe, NIST calibrated	01140458

Unit cooler - Embraco CRS (Black Evaporator Cover)

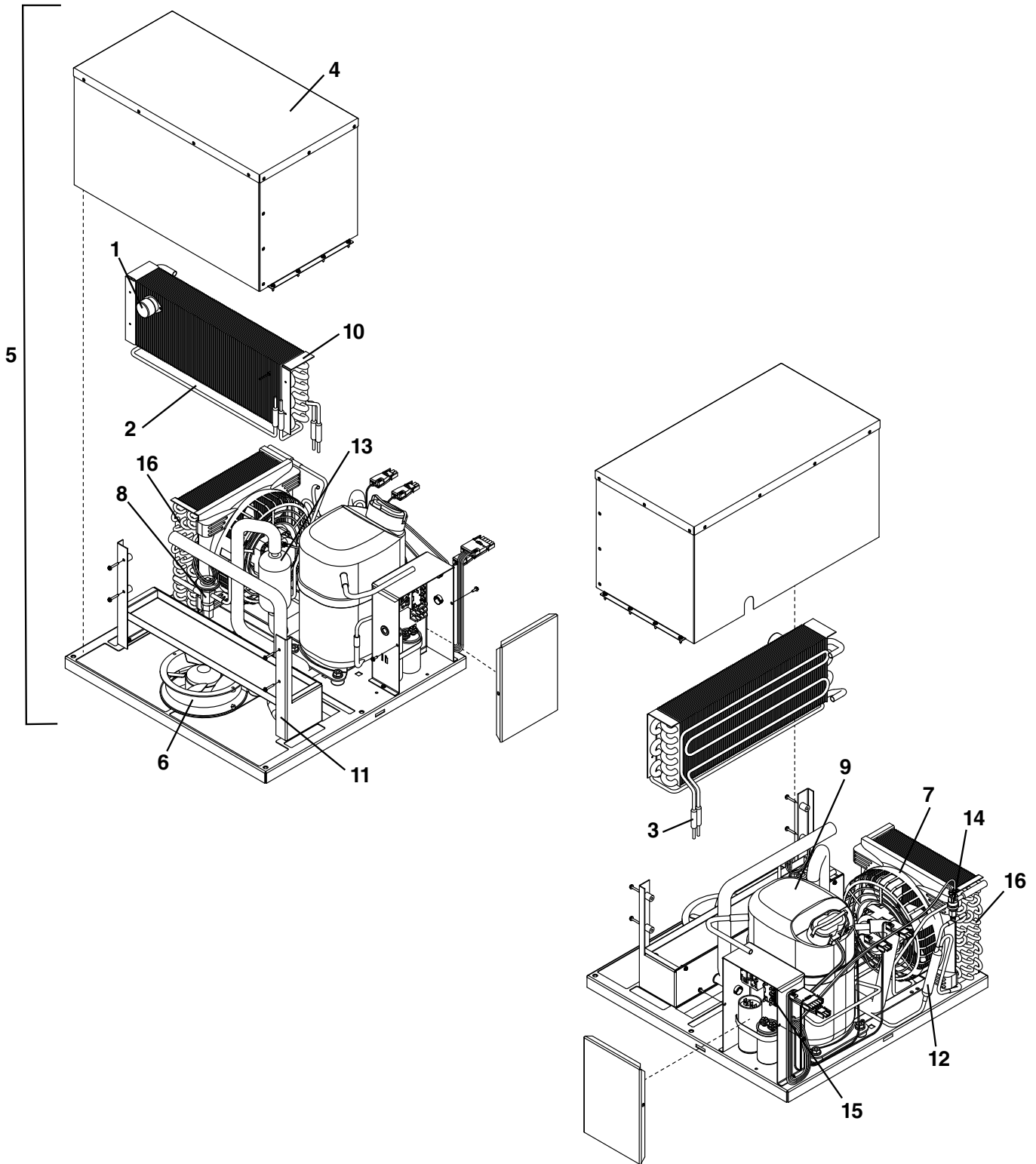

Embraco Unit Cooler

Reference	Description	Part #
1	Thermal overload, evaporator and drain pan	01349943
Not shown	Condensate drain tube with trap	01349968
Not shown	Heater, condensate drain tube	01349976
2	Defrost heater, drain pan	01349984
3	Defrost heater, evaporator (includes clips)	01349992
4	Evaporator cover (includes screws)	01350008
Not shown	Gasket, unit cooler	00912980
Not shown	Probe, evaporator, NTC (defrost probe also)	01334077
5	FZRVC cooling unit (includes gasket and mounting bolts)	01007004
6	Evaporator fan motor with blade	01350016
7	FZRVC condenser fan motor with blade	01350024
8	TXV FZRVC20/25 (includes clamps and insulation)	01350032
9	Compressor (includes overload and mounting grommets)	01350040
10	Evaporator (includes associated refrigerant tubing and insulation)	01350065
Not shown	Cord and plug kit, FZRVC - main power	00996595
11	Mounting bracket, evaporator	01350081
12	Filter drier	01350091
13	Accumulator (includes insulation)	01350107
14	HP switch	01350115
15	Contactora	01350123
16	Condenser coil and drier	01350131
Not shown	CRS test kit	01250141
Not shown	Start components	01350057
Not shown	CRS power cord	01402825

Facade

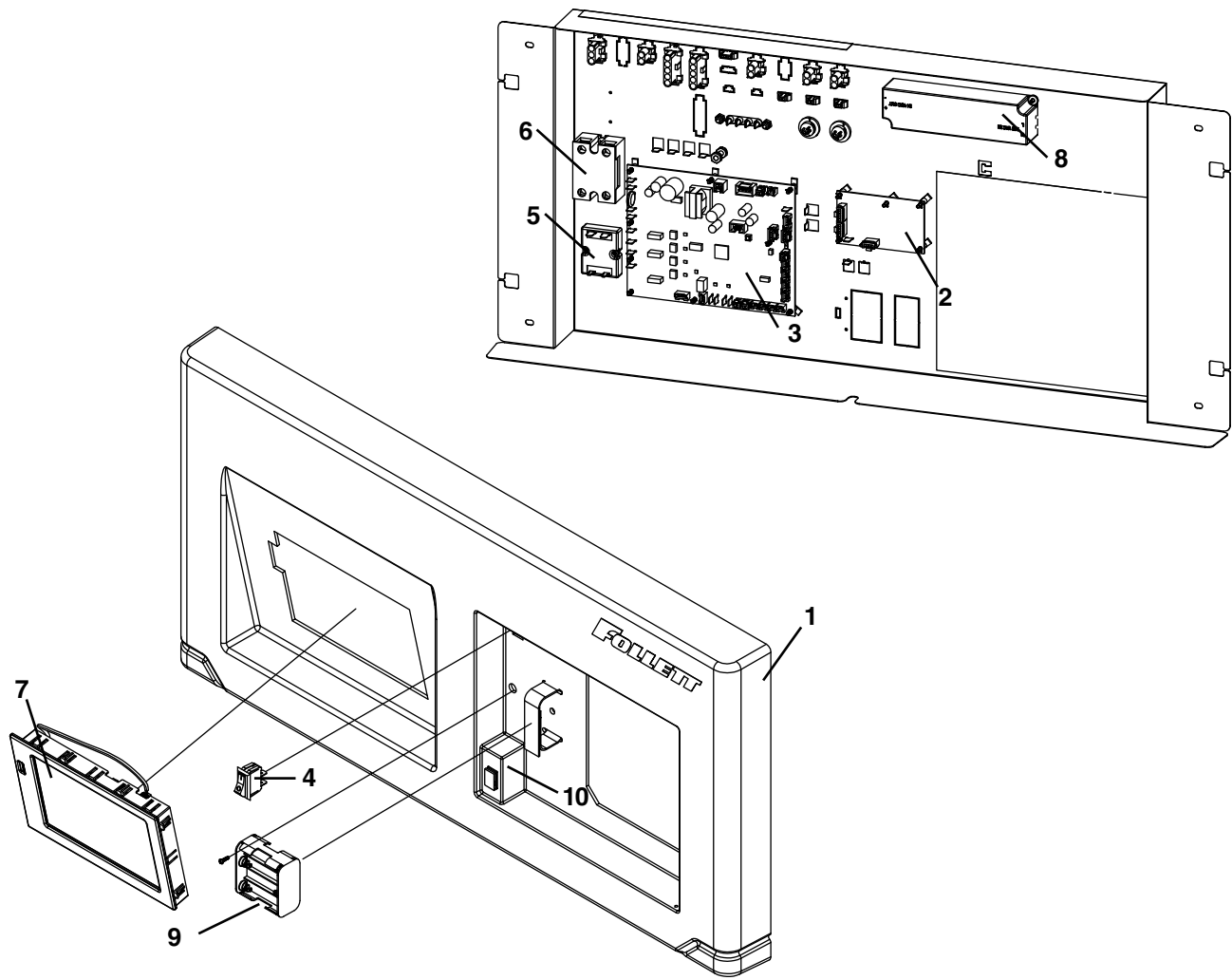

Reference	Description	Part #
1	Facade, cover, without chart recorder	01144054
2	RTD control board	01143965
3	Board, control, with hardware, UR FZRVAC-LB	01443167
Not shown	Panel, control, FZRVAC20/25	01443241
Not shown	Alarm terminal assembly	01092022
4	Power switch	207360
5	Defrost relay	01042092
6	Compressor relay	01223718
Not shown	Facade reed switch	01132091
7	Touchscreen	01124221
Not shown	Harness, control to touchscreen	01064856
8	LED power supply	00939801
Not shown	Bayonet, male	00179579
Not shown	Bayonet, female	00179556
Not shown	Facade locking clip	00931501
9	Battery pack	01053222
Not shown	Battery pack wiring harness	01040278

Reference	Description	Part #
Not shown	Batteries, AA	01053651
Not shown	Shell, upper side, REFVAC/FZRVAC 25	00940098
Not shown	Shell, upper side, REFVAC/FZRVAC 20	00925933
Not shown	Top ventilated cover	00991760
Not shown	Back support	00991965
Not shown	MOV assembly	01042258
Not shown	RTD probe harness, facade to control board	01106483
Not shown	NTC probe harness, facade to control board	01132075
10	Latch fastener	00901165

Door assembly

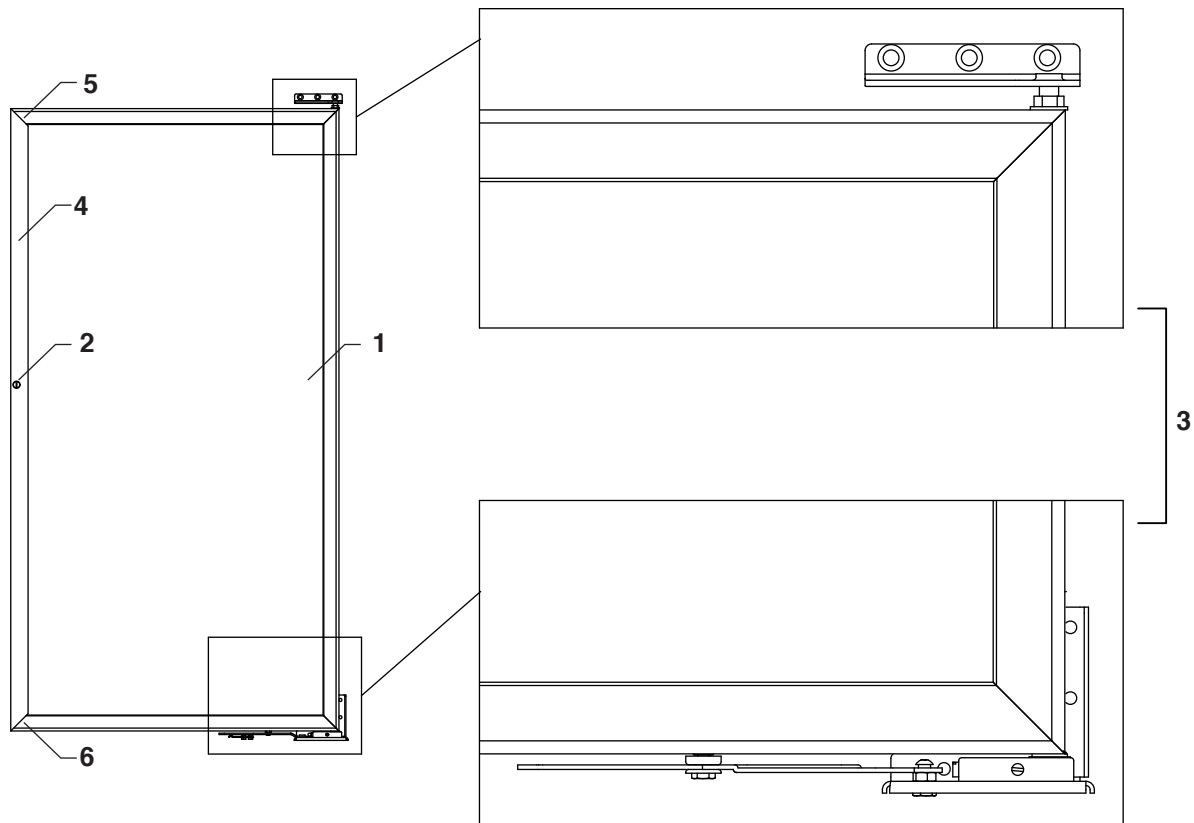

Reference	Description	Part #
Not shown	Door gasket, solid door	00960344
Not shown	Solid door, left-hand hinge	00996611
1	Solid door, right-hand hinge	00996603
2	Lock, glass door	00945444
Not shown	Key, solid door	01035013
Not shown	Lock, solid door	00996629
Not shown	Lock bracket	00939983
Not shown	Door magnet kit	00939967
3	Right-hand hinges with hardware	00996579
Not shown	Left-hand hinges with hardware	00996587
4	Solid door handle	00996637
5	Molded door handle cap, top	00989251
6	Molded door handle cap, bottom	00989244
Not shown	Seismic anchoring wall bracket	00927194
Not shown	Pyxis bracket kit	00927202
Not shown	Omicell bracket kit	00966432

Warranty Registration and Equipment Evaluation

Thank you for purchasing Follett® equipment. We hope you find that our equipment meets or exceeds your expectations, as our goal is to deliver high value products and services that earn your complete satisfaction!

Please review the enclosed installation and operations manual. It is important that the installation be performed to factory specifications, so your equipment operates to its maximum efficiency.

Follett LLC will not be liable for any consequential damages, expenses, connecting or disconnecting charges or any losses resulting from a defect of the machine.

For full warranty details, visit our website www.follettice.com/productwarranties.

Warranty registration and equipment evaluation is important to help us keep track of our equipment and to record the machine's performance. We request that you register Follett equipment warranties on our website www.follettice.com/support and choose Warranty Registration and Equipment Evaluation. It's simple to do; please take a moment to register today. There is also space on the form to provide us with comments and feedback. Please let us know about your experience so we can capture it for our continuous improvement efforts.

We pride ourselves on producing outstanding equipment and we work hard to back it up with outstanding customer and technical support. Please let us know what else we can do to assist you. We would be happy to answer your questions.

Registro de Garantía y Evaluación del Equipo

Gracias por haber elegido este producto Follett®. Esperamos que nuestro equipo cumpla o supere sus expectativas porque es nuestro objetivo ofrecer productos y servicios de gran valor que se ganen su plena confianza.

Le rogamos consulte el manual de instalación y de instrucciones adjunto, ya que es muy importante que la instalación se realice según las especificaciones de fábrica para que el equipo funcione a su máxima eficiencia.

Follett LLC no se hace responsable de los daños indirectos, costos, gastos por conexión y desconexión o pérdidas por causa de defecto de la máquina.

Si desea una información más completa sobre la garantía, visite nuestro sitio web www.follettice.com/productwarranties.

Las operaciones de registro de la garantía y evaluación del equipo son importantes para que podamos realizar un seguimiento de nuestro equipo y registrar el rendimiento de la maquinaria. Por favor, registre las garantías del equipo Follett en nuestro sitio web www.follettice.com/support y seleccione Registro de la Garantía y Evaluación del Equipo. Es muy sencillo, solo le llevará un momento realizar hoy mismo el registro. En el formulario incluimos un espacio en blanco para sus comentarios y opiniones. Infórmenos sobre su experiencia para que podamos incorporarla a nuestros continuos esfuerzos de mejora.

Nos enorgullecemos de producir un equipo excepcional y trabajamos duro para respaldarlo con un soporte técnico y un servicio de atención al cliente de primera. Le rogamos nos indique qué más podemos hacer para ayudarlo. Estaremos encantados de responder a sus dudas.

Enregistrement de la garantie et évaluation de l'équipement

Merci d'avoir acheté un équipement Follett®. Notre objectif étant d'offrir des produits et des services de grande valeur vous satisfaisant pleinement, nous espérons que celui-ci satisfera, voire dépassera, vos attentes !

Veillez consulter le manuel d'installation et d'exploitation. Il est important que l'installation soit réalisée conformément aux spécifications de l'usine, de sorte que votre équipement fonctionne à son rendement maximum.

Follett LLC n'est pas responsable de tout dommage consécutif, de toute dépense, de tout frais de raccordement ou de déconnexion, ni de toute perte liée à un défaut de la machine.

Pour lire la garantie dans son ensemble, visitez notre site Internet www.follettice.com/productwarranties.

L'enregistrement de la garantie et l'évaluation de l'équipement sont importants pour nous aider à suivre notre équipement et pour enregistrer les performances de la machine. Nous vous demandons donc d'enregistrer la garantie de votre équipement Follett sur notre site Internet, www.follettice.com/support, dans la section Warranty Registration and Equipment Evaluation. Cette opération est simple ; veuillez prendre un moment pour la réaliser aujourd'hui.

Le formulaire contient également un espace pour nous faire parvenir vos commentaires et un retour d'informations. Veuillez nous faire part de votre expérience pour que nous puissions prendre appui dessus pour poursuivre nos efforts constants d'amélioration.

Nous sommes fiers de produire des équipements exceptionnels et nous travaillons avec acharnement pour y associer une assistance à la clientèle et technique exceptionnelle. N'hésitez pas à nous indiquer dans quelle mesure nous pouvons vous aider. Nous serions ravis de répondre à vos questions.

Follett HEALTHCARE and Follett are registered trademarks of Follett Products, LLC, registered in the US.



801 Church Lane • Easton, PA 18040, USA
Toll free (877) 612-5086 • +1 (610) 252-7301
www.follettice.com/healthcare

01441500R01
© Follett Products, LLC 8/22