

SinBAD II

Single Basket Dispenser Service and Parts Manual

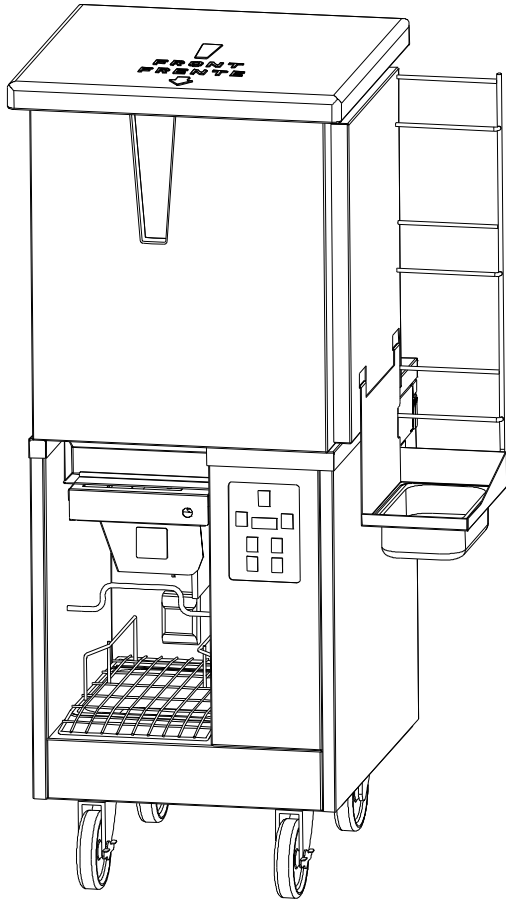

 **Frymaster**[®]



CFESA
Commercial Food Equipment Service Association

Frymaster, a member of the Commercial Food Equipment Service Association, recommends using CFESA Certified Technicians.

24-Hour Service Hotline 1-800-551-8633

819-5875
MARCH 2005



DANGER

IMPROPER INSTALLATION, ADJUSTMENT, ALTERATION, SERVICE, OR MAINTENANCE CAN CAUSE PROPERTY DAMAGE, INJURY, OR DEATH. READ THE INSTALLATION, OPERATING, AND SERVICE INSTRUCTIONS THOROUGHLY BEFORE INSTALLING OR SERVICING THIS EQUIPMENT.



DANGER

FOR YOUR SAFETY, DO NOT STORE OR USE GASOLINE OR OTHER FLAMMABLE LIQUIDS OR VAPORS IN THE VICINITY OF THIS OR ANY OTHER APPLIANCE.

THIS EQUIPMENT IS TO BE INSTALLED IN COMPLIANCE WITH THE BASIC PLUMBING CODE OF THE BUILDING OFFICIALS AND CODE ADMINISTRATORS INTERNATIONAL, INC. (BOCA) AND THE FOOD SERVICE SANITATION MANUAL OF THE FOOD AND DRUG ADMINISTRATION.

COMPUTERS

FCC

This device complies with Part 15 of the FCC rules. Operation is subject to the following two conditions:

1) This device may not cause harmful interference, and 2) This device must accept any interference received, including interference that may cause undesired operation. While this device is a verified Class A device, it has been shown to meet the Class B limits.

CANADA

This digital apparatus does not exceed the Class A or B limits for radio noise emissions as set out by the ICES-003 standard of the Canadian Department of Communications.

Cet appareil numerique n'emet pas de bruits radioelectriques depassany les limites de classe A et B prescrites dans la norme NMB-003 edictee par le Ministre des Communcations du Canada.

**SinBaD II SINGLE BASKET DISPENSER
TABLE OF CONTENTS**

CHAPTER 1: Technician Troubleshooting

1.1	Functional Description.....	1-1
1.2	Troubleshooting and Problem Isolation.....	1-2
1.2.1	Failures to “Zero”.....	1-2
1.2.2	Erratic or Inaccurate Batch Weights.....	1-3
1.2.3	Failures to Function and Improper Functioning.....	1-3
1.3	Troubleshooting Guides.....	1-4
1.4	Wiring Diagrams	1-10

CHAPTER 2: Replacing Components

2.1	Accessing Components.....	2-1
2.2	Replacing Components.....	2-1
2.2.1	Replacing the Controller.....	2-1
2.2.2	Replacing the Load Cell and Associated Components.....	2-1
2.2.3	Replacing the Dispense Motor	2-2
2.2.4	Replacing the Drum Motor.....	2-4
2.2.5	Replacing the Transformer or Line Filter.....	2-4
2.2.6	Replacing the Proximity Sensor	2-5
2.2.7	Replacing the Motor Interface Board	2-5

CHAPTER 3: Parts List

Accessories.....	3-1
Cabinetry.....	3-2
Dispense System Components	3-4
Drum Motor Components	3-6
Electronics.....	3-7
Wiring	3-8

SimBaD II SINGLE BASKET DISPENSERS

CHAPTER 1: TECHNICIAN TROUBLESHOOTING

1.1 Functional Description

When the unit is plugged into an electrical outlet, line voltage is supplied to the transformer. Placing the ON/OFF switch in the ON position supplies 24VAC to the motor interface board. The motor interface board supplies 12VDC to the controller and 24VDC to the dispense motor and drum motor. The drum motor will activate briefly as the computer in the controller “wakes up,” then motor logic circuits in the controller will turn it back off. If closed, the dispensing chute door will open and remain open.

When the ON/OFF switch is placed in the ON position, the controller automatically enters the STANDBY mode. When in the STANDBY mode, the batch weight selector switch circuits are disabled and the CLEAN and PROGRAM circuits are enabled. No indicator LEDs are illuminated when the unit is in the STANDBY mode.

Pressing the RUN switch places the controller in the RUN mode and causes the RUN mode indicator above the switch to illuminate. Every time the unit is placed in the RUN mode, the controller will perform an initialization process to “zero” the load cell. The dispensing chute door will open and remain open throughout the process to ensure accuracy. When in the RUN mode, the batch weight selector switch circuits are enabled and the CLEAN and PROGRAM circuits are disabled.

The load cell is an aluminum bar that acts as a bridge resistor. One end of the load cell is fixed. The load cell arms, dispensing chute, and dispense motor are attached to the opposite end. Their weight causes a slight distortion of the bar, which changes the bar’s resistance.

During the zeroing process, circuitry in the controller measures the resistance associated with the weight of the empty dispensing chute, the dispense motor, and the load cell arms. It compares this to a factory-programmed resistance range and, if within the range, records this as the “zero” value. If the resistance is outside of tolerance, the unit goes into a zero failure mode, signified by blinking of the RUN mode indicator and the PROGRAM mode indicator.

During programming of the batch selector switches, the controller measures the difference between the previously determined “zero” resistance and the resistance associated with the new weight. It records the differential so that a batch weight always corresponds to the “zero” resistance plus the differential resistance, not a specific resistance value. This avoids erratic batches caused by fluctuations in the “zero” weight.

When a batch weight selector is pressed, the controller activates the drum motor to transfer fries to the dispensing chute. When the fries enter the chute, their weight further distorts the load cell, causing a change in resistance. When the resistance is equal to the “zero” resistance plus the resistance differential associated with the batch weight selector pressed, the controller signals the drum motor to stop.

A proximity sensor at the rear of the dispensing well senses when a basket has been inserted into the well. It signals the controller, which in turn activates the dispense motor to dump the fries. When the door reaches the full open position, a flag on the dispense motor shaft is detected by a Hall effect sensor that signals the controller. The controller in turn reverses the current to the motor, closing the door. When the door reaches the closed position, another Hall effect sensor detects the flag on the motor shaft and signals the controller. The controller reduces power to the dispense motor to approximately 1VDC, causing the motor to hold the door closed. A built-in 1½-second delay allows the load cell to stabilize before the controller reactivates the drum motor to reload the dispensing chute. If a basket has been pre-positioned beneath the dispensing chute, the unit will dispense the batch as soon as the load cell is satisfied and begin loading another batch. The

second batch will be held until the first basket is removed and another basket is inserted. The process continues until the unit is placed in the STANDBY mode or the ON/OFF switch is placed in the OFF position.

1.2 Troubleshooting and Problem Isolation

This section is intended to provide technicians with a general knowledge of the broad problem categories associated with this equipment, and the probable causes of each.

Problems you are likely to encounter can be grouped into three broad categories:

- a. Failures to “zero” (unit does not properly initialize when the unit is turned on)
- b. Erratic or inaccurate batch weights (the weight of dispensed batches is incorrect)
- c. Failures to function (the unit or one of its components does not operate at all or malfunctions)

A series of troubleshooting guides is also included at the end of the chapter to assist in identifying some of the more common problems.

1.2.1 Failures to “Zero”

As discussed in Section 1.1, the unit determines batch weights by comparing the load cell resistance to a prerecorded resistance value equal to the empty or “zero” resistance value plus a resistance differential value corresponding to a particular batch weight. When the load cell resistance is equal to the “zero” resistance plus the resistance differential, the load cell is “satisfied” and the drum motor is stopped. Although each load cell is theoretically identical, in actuality any given cell may have a slightly different resistance from any other cell. Consequently, the cell must be “zeroed” to determine and record its actual resistance in order to ensure accurate batch weights. The unit must be “zeroed” with the dispense chute in place, and no part of the dispense chute may be in contact with the cabinet.

The load cell itself is basically an aluminum bar. When not under stress, it has a particular resistance. When the bar is vertically distorted by applying weight to one end, the resistance changes. Also, if the bar contacts any other component, such as the end of the dispense motor shaft, its resistance will be changed, forcing it outside the acceptable range. Circuitry within the controller measures the load cell resistance and compares this to a factory-programmed (and very narrow) range. As long as the load cell resistance falls within this range, the unit will “zero.”

Other than the load cell or an associated component being in contact with something it shouldn't, there are only two probable causes for failing to “zero.” The first is a failed load cell. Failure may be caused by bending of the cell or by damage to the cabling. Because the resistance range is narrow, it is usually impossible to see the damage, so the appearance of the load cell is not a good indicator of load cell failure, although an obviously damaged cell is immediately suspect. If the load cell is good, the only other cause is a malfunctioning controller. If the controller cannot measure load cell resistance or loses the programmed

Load Cell Assembly

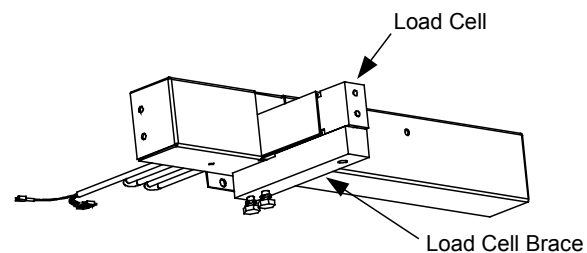

resistance range, it cannot “zero.” In either situation, the only solution is to replace the failed component, but before doing that perform the following checks:

- a. Verify the load cell brace is not touching the end of the dispense motor shaft. (Do this by trying to insert a piece of paper between the two. If it can be inserted without drag, it’s okay.)
- b. Verify no part of the dispense chute is touching the cabinet.

A Load Cell Simulator Kit (P/N 826-1746) is available to help technicians determine if the problem is with the load cell or the controller. Detailed instructions for using the simulator are included with the kit.

If a simulator is not available, the recommended method of isolating the failed component is by substitution, starting with the controller. It is not necessary to install a controller to test it. Simply plug the cabling into the new controller. If the unit “zeroes,” the controller in the unit has failed and should be replaced with the new one; if not, it is most likely the load cell that has failed.

If the unit “zeroes” sometimes but fails at others, check for a loose connection at the controller.

1.2.2 Erratic or Inaccurate Batch Weights

The probable causes of erratic or inaccurate batch weights are bumping or jarring of the unit while the drum motor is running and improper programming of the batch weight selectors.

The unit should be positioned in an area where it is not likely to be bumped or jarred during operation. If erratic or inaccurate batch weights occur at random intervals, it is likely that the unit is being bumped or jarred by workers. The only solutions in this case are to move the unit or better educate employees about the effects of bumping the unit during operation.

If the erratic or inaccurate batch weights occur at specific times, or if the problem comes and goes, it may be that there is a source of unusual vibration. Two things to consider are facility location (e.g., is it close to a railroad track or to a highway where heavy trucks pass on a regular schedule) and unit location (e.g., is it next to a heavy door that slams shut), etc. In the case of facility location not much can be done, although it may be possible to dampen the vibrations by placing the unit on a thick pad. In the case of unit location, consider moving the unit.

If erratic or inaccurate batch weights occur consistently, it is likely that one or more of the batch weight selectors have been improperly programmed. Verify that the selectors have been properly programmed in accordance with the instructions in Chapter 3 of the Installation and Operation Manual furnished with the unit.

1.2.3 Failures to Function and Improper Functioning

The probable causes of this category of problem are improper connections and failed components. If you have not already done so, you should read Section 1.1 (the system theory of operation) before continuing with this section.

The paragraphs that follow identify the general types of failures that may be encountered and the possible causes of each. Troubleshooting Guides at the end of the chapter provide step-by-step problem-isolation procedures.

Failure of the unit to initialize when ON/OFF switch is placed in ON position can be caused by failure of a component in the input power circuit or failure of the controller. When the ON/OFF switch is placed in the

ON position the two error conditions that may be encountered are that the drum motor does not activate at all or it runs continuously.

Normally when the ON/OFF switch is placed in the ON position, the drum motor briefly activates (approximately 2 seconds) then stops. If the drum motor runs continuously as soon as the ON/OFF switch is placed in the ON position, there are three probable causes. The first is that 12VDC is not getting to the controller from the motor interface board. The second is that the controller has failed. The third is that controller signals are not reaching the motor drive circuits.

If the drum motor does not activate at all, the probable causes are failure of a component in the input power circuit.

Failures of the dispense chute door to open or close are caused by problems with the Hall effect sensors, the proximity sensor, the dispense motor, the motor interface board, or the controller. The primary indication of a problem involving the “closed” Hall effect sensor (J8 on the controller) is the partial closing of the door following the “zero” routine or the removal and replacement of a basket during normal operation.

A failed “open” Hall effect sensor (J8 on the controller) is indicated by the normal “zeroing” of the unit and loading of the dispense chute, but failure of the door to open to dispense the fries. A failed proximity sensor will give the same indication, so care must be taken to differentiate between the two.

If the Hall effect sensors have been ruled out as the cause of the failure to function, the most likely cause is a motor-related problem.

Failures of the drum motor to start or stop are caused by problems in the controller, load cell, motor interface board, or drum motor and the associated wiring. If the motor fails to stop, the problem is not with the motor. It may be with the controller, the load cell, or the motor interface board.

1.3 Troubleshooting Guides

The Troubleshooting Guides that follow provide a systematic method for isolating specific problems and the action(s) to take to correct them. Also, don’t forget the Operator Troubleshooting Guides found in Chapter 3. Most problems likely to be encountered are covered in these two sets.

However, don’t hesitate to call the ***Frymaster*** Technical Services Department at 1-800-551-8633 if you need assistance in solving a particular problem.

Problem	Probable Causes	Corrective Action
<p style="text-align: center;">NO POWER WITH UNIT VERIFIED TO BE PLUGGED IN AND CIRCUIT BREAKER VERIFIED TO BE ON.</p>	<p>A. Failed power cord.</p> <p>Test: Check for line voltage on the line side of the line filter. If not present, the power cord has failed.</p>	<p>A. Replace the power cord.</p>
	<p>B. Failed line filter.</p> <p>Test: Check for line voltage on the line side of the filter and on the load side. If line voltage is present on the line side but not the load side, the filter has failed.</p>	<p>B. Replace the line filter.</p>
	<p>C. Failed ON/OFF switch.</p> <p>Test: Check for line voltage on the load side of the line filter and on the transformer brown and blue wires. If line voltage is present on the load side of the filter but not on the transformer brown and blue wires, the switch has failed.</p>	<p>C. Replace the ON/OFF switch.</p>
	<p>D. Failed transformer.</p> <p>Test: Check for line voltage on the transformer brown and blue wires and 24VAC on the black and orange wires and 12VAC on the black and yellow wires. If line voltage is present on the transformer brown and blue wires, and either of the other two voltages is incorrect, the transformer has failed.</p>	<p>D. Replace the transformer.</p>
	<p>E. Failed motor interface board.</p> <p>Test: Check for 12VDC on connector J3 of the board. If voltage is incorrect, the board has failed.</p>	<p>E. Replace the motor interface board.</p>
	<p>F. Failed 12VDC power cable.</p> <p>Test: Check for 12VDC on connector J3 of the motor interface board. If voltage is correct, the 12VDC power cable has failed.</p>	<p>F. Replace the 12VDC power cable.</p>

Problem	Probable Causes	Corrective Action
UNIT WILL NOT ZERO.	<p>A. Failed controller.</p> <p>Test 1: <i>If a load cell simulator is available</i>, disconnect the load cell from the controller and connect the simulator. Turn unit off then back on using the ON/OFF switch. Press the RUN switch. If the unit does not zero, the controller has failed.</p> <p>Test 2: <i>If a load cell simulator is not available</i>, turn unit off then back on using the ON/OFF switch. Press the RUN switch and look for the following conditions:</p> <ol style="list-style-type: none"> 1. Drum motor activates briefly, then stops. 2. Indicators in RUN switch and PROGRAM switch do not flash. <p>If both conditions are true, the controller is suspect.</p>	<p>A. Replace the controller.</p> <p>NOTE: Before installing a new controller, plug the cabling into the new controller, turn the unit off then back on using the ON/OFF switch, and press the RUN switch. If the unit zeroes, the diagnosis is confirmed and the replacement computer can then be installed. If the unit still does not zero, the problem is not with the controller.</p>
	<p>B. Failed load cell.</p> <p>Test 1: <i>If a load cell simulator is available</i>, disconnect the load cell from the controller and connect the simulator. Turn unit off then back on using the ON/OFF switch. Press the RUN switch. If the unit zeroes, the load cell is suspect.</p> <p>Test 2: <i>If a load cell simulator is not available</i>, turn unit off then back on using the ON/OFF switch. Press the RUN switch and look for the following conditions:</p> <ol style="list-style-type: none"> 1. Drum motor activates briefly, then stops. 2. Indicators in RUN switch and PROGRAM switch flash. <p>If both conditions are true, and a piece of paper can be inserted between the dispense motor shaft and the load cell brace, the load cell has failed.</p>	<p>B. Replace the load cell.</p> <p>NOTE: Before replacing a load cell, verify that a piece of paper can be inserted between the dispense motor shaft and the load cell brace. If not, the load cell is out of alignment. Refer to Section 2.2.2 for corrective action.</p>
	<p>C. Loose or broken load cell cable.</p> <p>Test: Check connection to verify that the cable is securely plugged into connector J3 on the controller.</p>	<p>C. If the cable is loose, reconnect it. If the cable is broken, replace the load cell.</p>

Problem	Probable Causes	Corrective Action
BATCH WEIGHTS ARE INCONSISTENT OR INACCURATE.	A. Unit is located in an area where it is being bumped or jarred during operation.	A. Relocate unit to an area where it is less likely to be bumped or jarred during operation. Ensure unit is not in contact with adjacent walls.
	B. Unit is in an area subject to unusual environmental vibration, such as adjacent to a railroad track or near a major highway.	B. Placing the unit on a thick mat may lessen the effect of environmental vibrations.
	C. Batch weight selectors are incorrectly programmed.	C. Reprogram batch weights in accordance with Section 2.4 of the Installation and Operation Manual.
DRUM MOTOR RUNS CONTINUOUSLY AS SOON AS THE ON/OFF SWITCH IS PLACED IN THE ON POSITION.	<p>A. 12VDC is not getting to the controller.</p> <p>Test 1: Check for 12VDC at motor interface board connector J3. If voltage is not present, probable cause is failure of the motor interface board. If voltage is present, perform Test 2.</p> <p>Test 2: Check for 12VDC at the controller end of the 12VDC cable. If voltage is present on connector J3 but not at controller end of the cable, the cable has failed. If voltage is present at the controller end of the cable the controller is suspect. Go to B.</p> <p>B. Failed controller.</p> <p>Test: Substitute new controller for suspect controller. Turn unit off and back on using the ON/OFF switch. Press RUN switch. If unit functions correctly, the controller has failed.</p>	<p>D. Failed Test 1 – Replace the motor interface board.</p> <p>Failed Test 2 – Replace the 12VDC power cable.</p> <p>E. Replace the controller.</p>
DRUM MOTOR DOES NOT ACTIVATE AT ALL.	<p>A. Failed drum motor.</p> <p>Test: With loading chute empty, turn the unit off then back on using the ON/OFF switch. Press the RUN switch. Check for 24VDC at motor end of drum motor cable. If voltage is present, the drum motor has failed.</p>	A. Replace the drum motor.
	<p>B. Failed motor interface board.</p> <p>Test: Check for 24VAC at connector J1 of the motor interface board. If voltage is present and a motor known to be good does not activate when RUN switch is pressed, the motor interface board may have failed.</p>	<p>B. Replace the motor interface board.</p> <p>NOTE: Before replacing the motor interface board, check the continuity of the drum motor cable to be sure it is not the problem.</p>

Problem	Probable Causes	Corrective Action
<p>DISPENSE CHUTE DOOR DOES NOT CLOSE AFTER A BATCH HAS BEEN DISPENSED.</p> <p>(If the door did not close after the unit was first started and the LEDs in the RUN and PROGRAM switches are flashing, refer section B (Failed Load Cell) on Page 1-6.)</p>	<p>A. Failed dispense motor.</p> <p>Test: Turn the unit off then back on using the ON/OFF switch, then press the RUN switch. After the unit zeroes, check for 24-35VDC on the motor end of the dispense motor cable. If voltage is present, the dispense motor has failed.</p>	<p>A. Replace the dispense motor.</p>
	<p>B. Failed motor interface board or dispense motor cable.</p> <p>Test: Turn the unit off then back on using the ON/OFF switch, then press the RUN switch. After the unit zeroes, check for 24-35VDC on J5 of the motor interface board. If voltage is not present, the motor interface board has failed. If voltage is present, the dispense motor cable has failed.</p>	<p>B. Replace the motor interface board or dispense motor cable as required.</p>
	<p>C. Failed/misaligned lower Hall effect sensor.</p> <p>Test: If the unit zeroes and the door partially closes, the lower Hall effect sensor is out of alignment or has failed.</p>	<p>C. Realign or replace the lower Hall effect sensor as necessary.</p>
	<p>D. Failed controller.</p> <p>Test: Disconnect the cables from the suspect controller and connect them to a controller known to be good. Turn the unit off then back on using the ON/OFF switch, then press the RUN switch. If the unit operates correctly, the controller has failed.</p>	<p>D. Replace the controller.</p>

1.4 Wiring Diagrams

100VAC CONFIGURATION

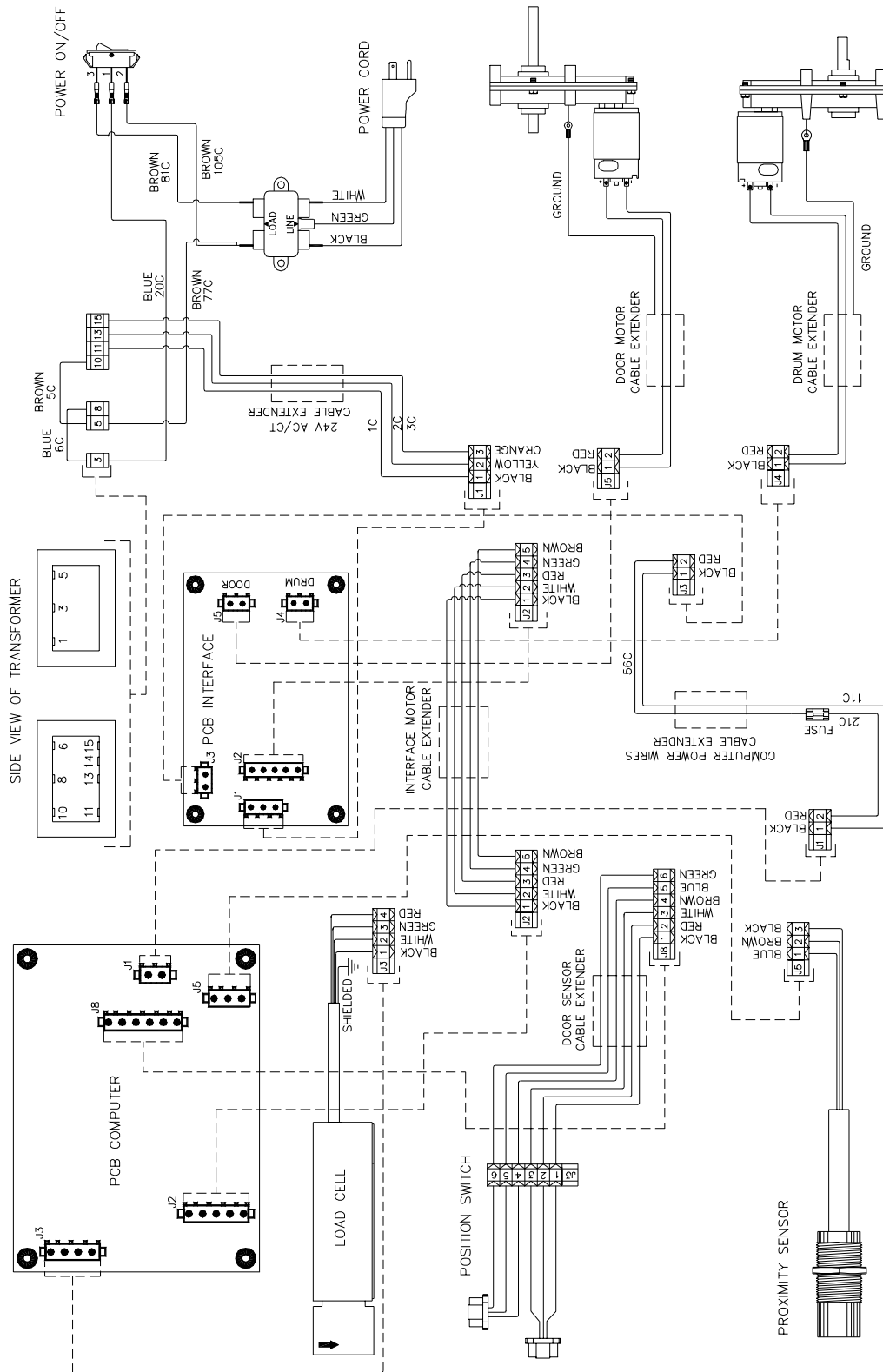

8051168D

115VAC CONFIGURATION

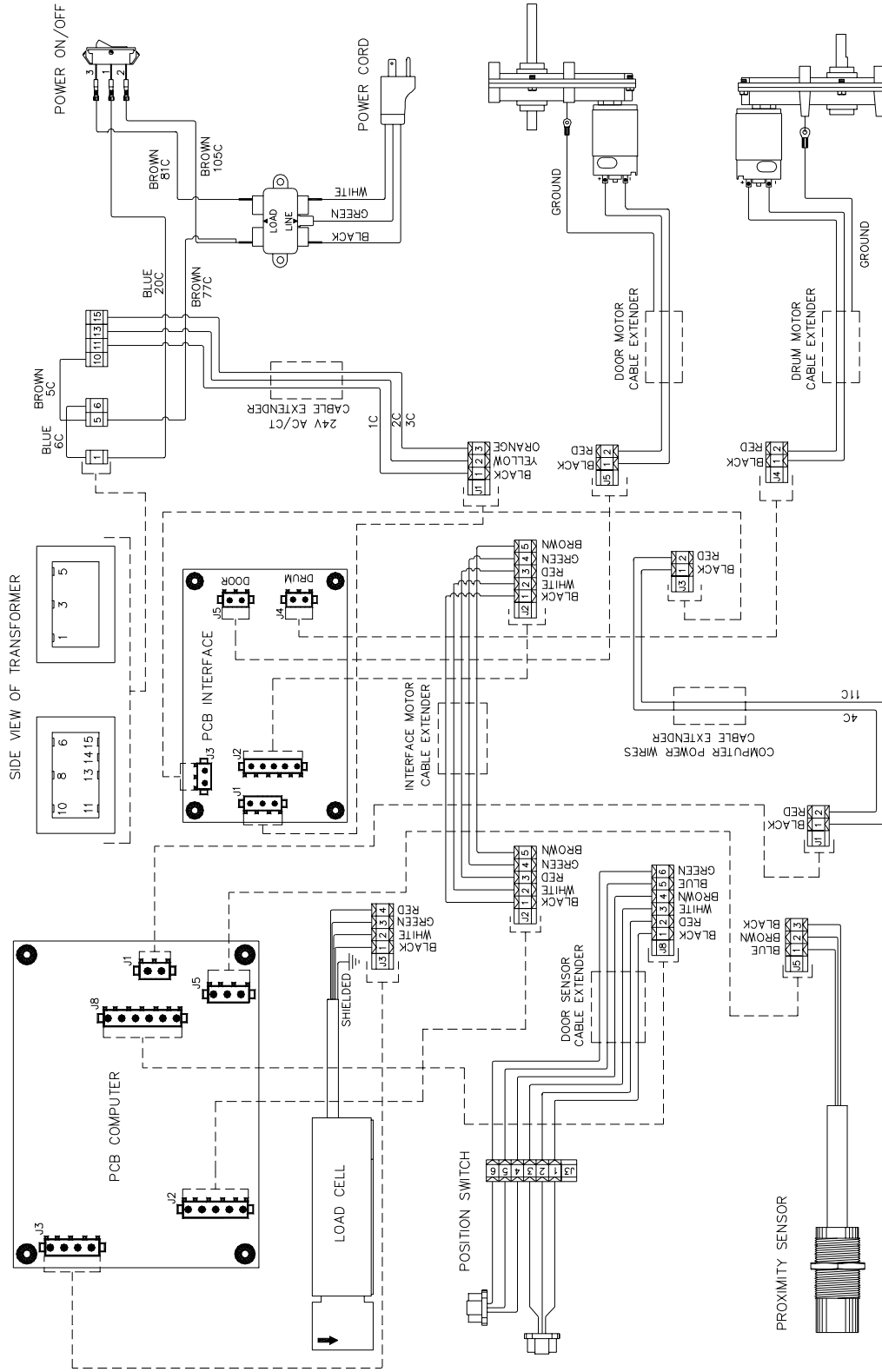

8051151E

220VAC CONFIGURATION

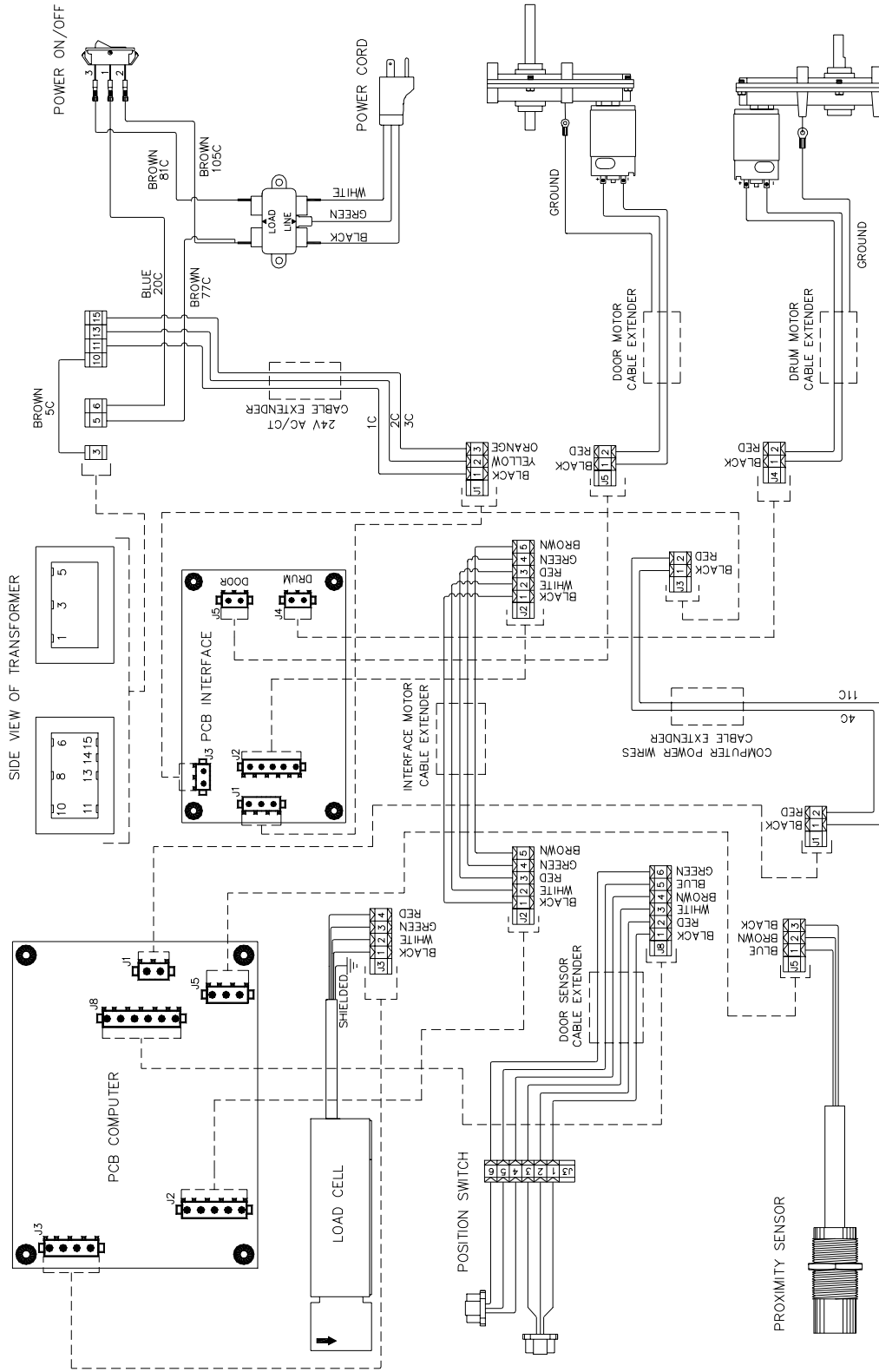

8051319B

CE 230VAC CONFIGURATION

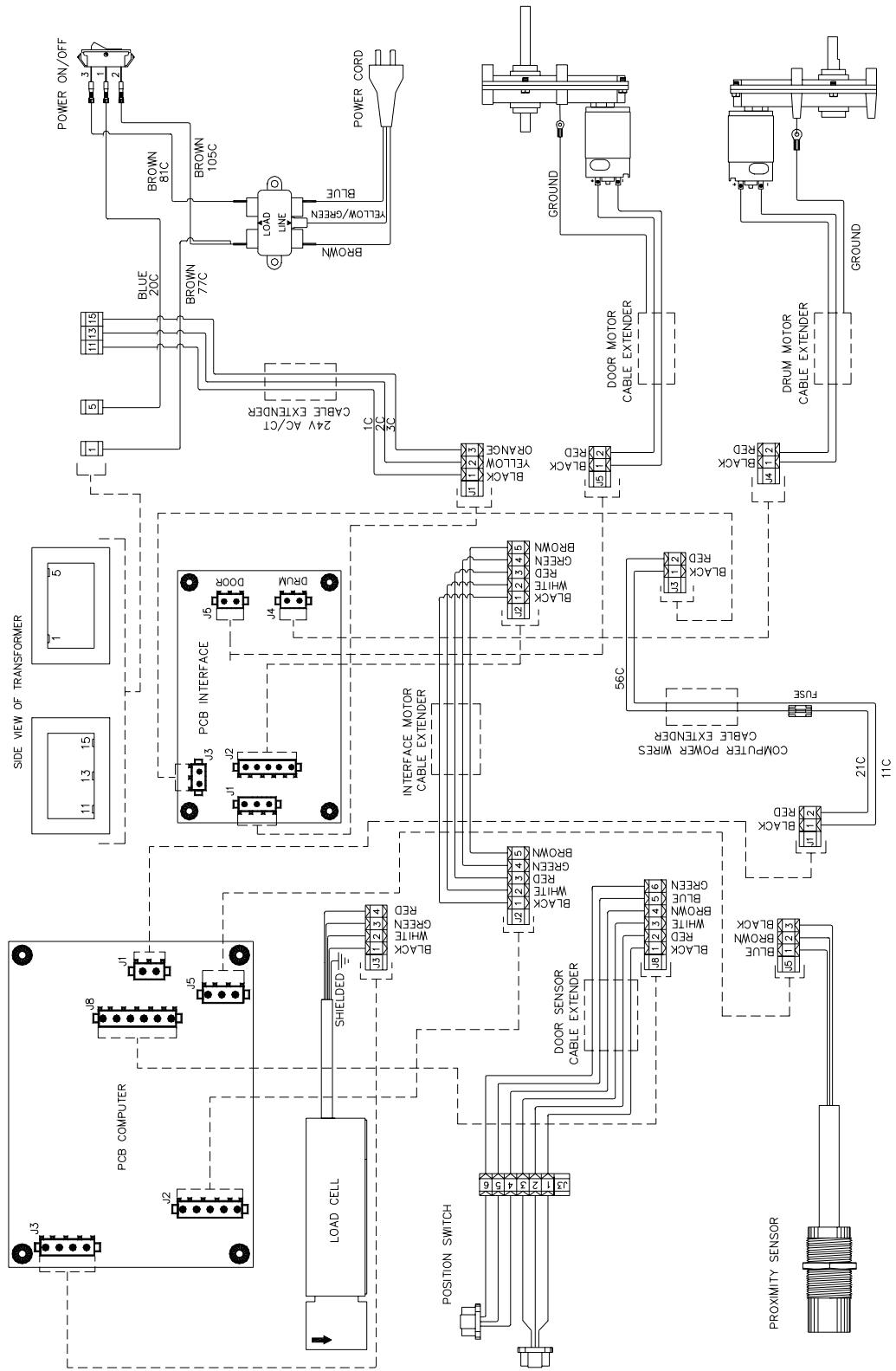

8051321B

NOTE: PROXIMITY SENSOR AND HALL EFFECT SENSORS SHOWN AS FUNCTIONAL SWITCHES FOR SIMPLICITY. LOAD CELL CIRCUITRY NOT ILLUSTRATED FOR SAME REASON.

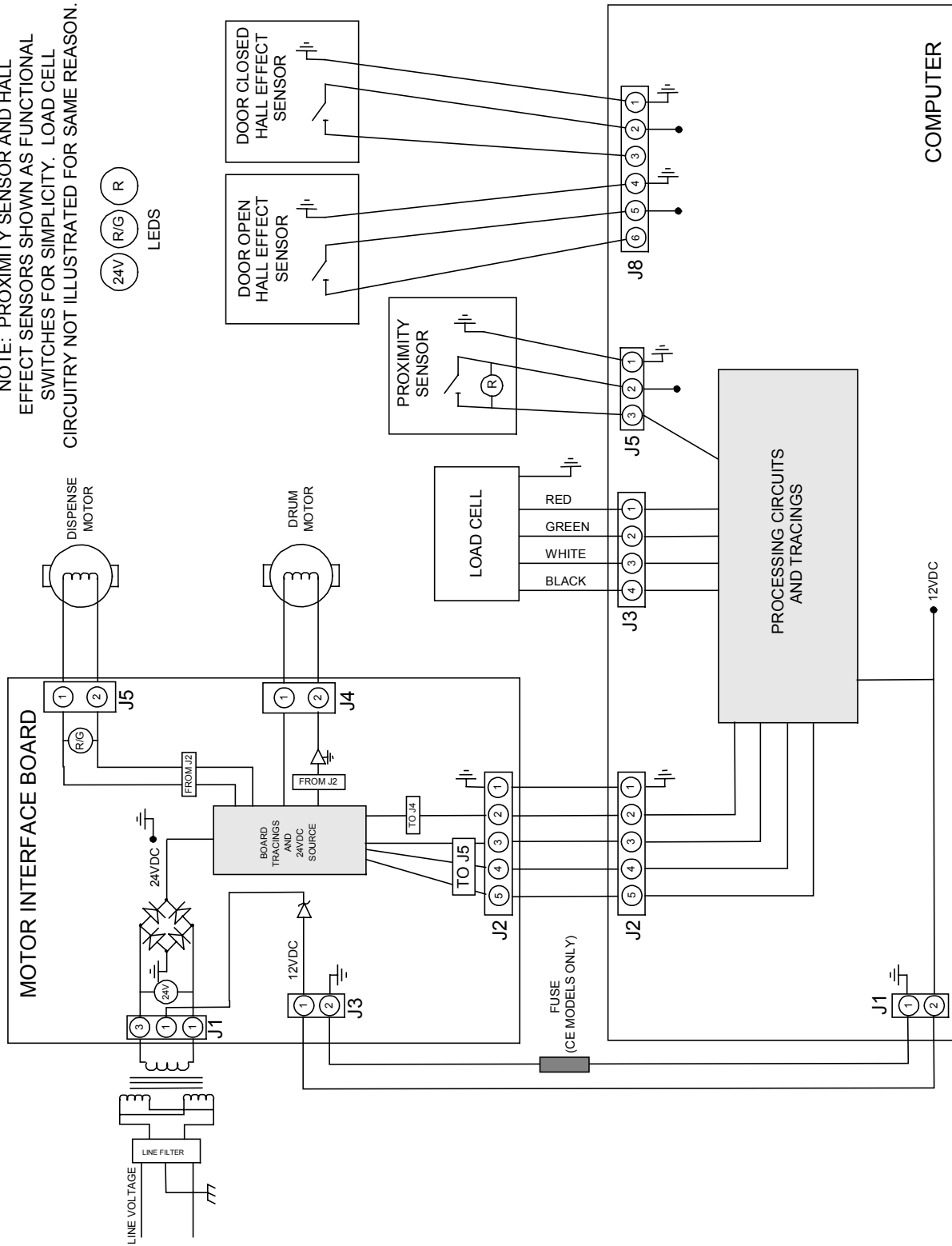

SIMPLIFIED WIRING DIAGRAM

PRIMARY TRANSFORMER		OPTIONAL TRANSFORMER	
V & F TRANSFORMER CORP, F5P31		BASLER ELECTRIC BE 29815 001	
<p>24VCT@2.0A</p> <p>100VAC 50/60Hz</p>	<p>24VCT@2.0A</p> <p>115VAC 50/60Hz</p>	<p>24VCT@2.0A</p> <p>100VAC 50/60Hz</p>	<p>24VCT@2.0A</p> <p>115VAC 50/60Hz</p>
<p>24VCT@2.0A</p> <p>200/208VAC 50/60Hz</p>	<p>24VCT@2.0A</p> <p>230/240/250VAC 50/60Hz</p>	<p>24VCT@2.0A</p> <p>200/208VAC 50/60Hz</p>	<p>24VCT@2.0A</p> <p>230/240/250VAC 50/60Hz</p>

SinBAD II SINGLE BASKET DISPENSER

CHAPTER 2: REPLACING COMPONENTS

2.1 Accessing Components

The unit's back panel must be removed to access all electronic components except the drum motor. The panel is held in place by two hex-head screws located along the bottom edge. A separate access panel must be removed to gain access to the drum motor. It is held in place with two hex-head screws. In order to access the ON/OFF switch and controller, the right cabinet top must also be removed. It is secured by two pan-head machine screws and Keps nuts at the left rear corner (as viewed from the rear of the unit) and one hex-head screw at the right rear corner. The front of the panel is held in place by a pair of tabs that fit into slots cut into the front of the cabinet. When the retaining screws have been removed, lift up on the rear and move the cabinet top toward the front to disengage the tabs.

2.2 Replacing Components

2.2.1 Replacing the Controller

1. Disconnect the unit from the electrical power source.
2. Disconnect all cables from the jacks on the back of the controller. If the cables are not marked indicating their jacks, mark the cables before disconnecting them.
3. The controller is held in place by four Keps nuts. Remove the nuts and pull the controller straight rearward off the mounting studs.
4. Reverse steps 1-3 to install new controller.

2.2.2 Replacing the Load Cell and Associated Components

1. Disconnect the unit from the electrical power source.
2. Disconnect the load cell cable from the back of the controller (see photo below).

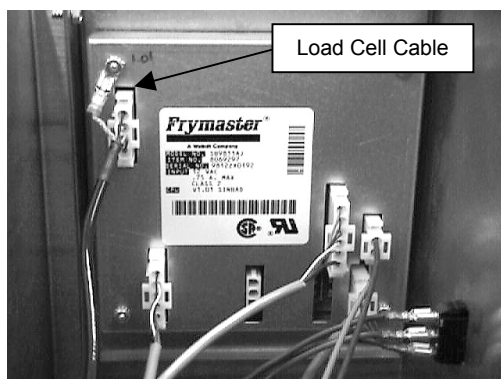

3. Remove the dispensing chute by lifting it up from the load cell arms and carefully sliding it toward you (see illustration at right).

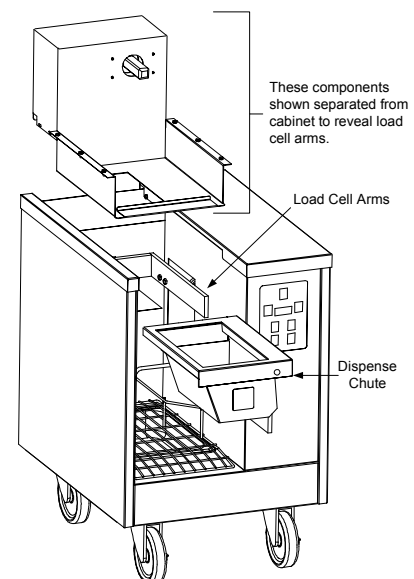

- Remove the two bolts securing the load cell arms to the load cell (see illustration at right). Carefully lower the load cell arms/dispense motor assembly to the bottom of the dispense chamber.
- Remove the two bolts securing the load cell/load cell brace assembly to the load cell saddle (see illustration below) and remove the load cell and load cell brace.

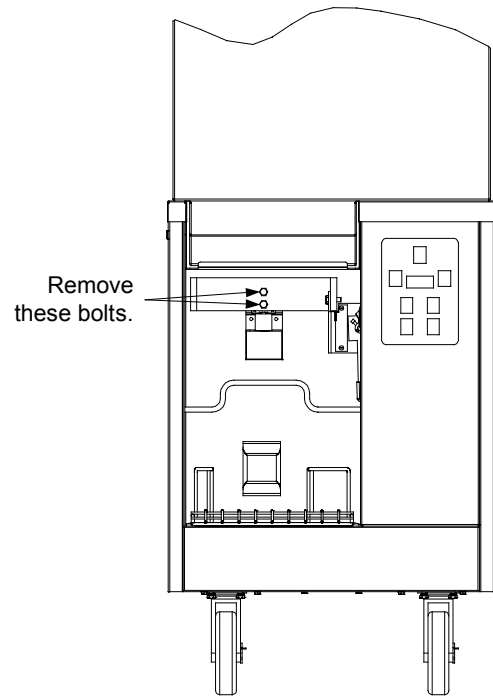
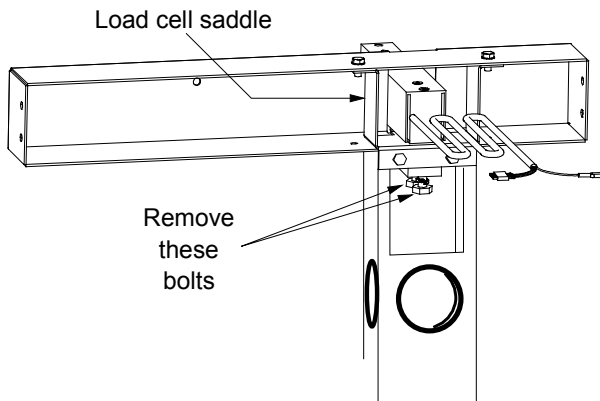

- Reattach the replacement load cell and the load cell brace to the load cell saddle and securely tighten the bolts. Verify that the gap between the load cell and stop screw in the load cell brace is approximately .015 inch \pm .005 inch (.4mm \pm .13mm).
- Reverse steps 1 through 4 to complete the procedure.

2.2.3 Replacing the Dispense Motor

- Disconnect the unit from the electrical power source and remove the back panel to access wiring.
- Disconnect the dispense motor wiring harness and Hall Effect sensor cable (see photo below).

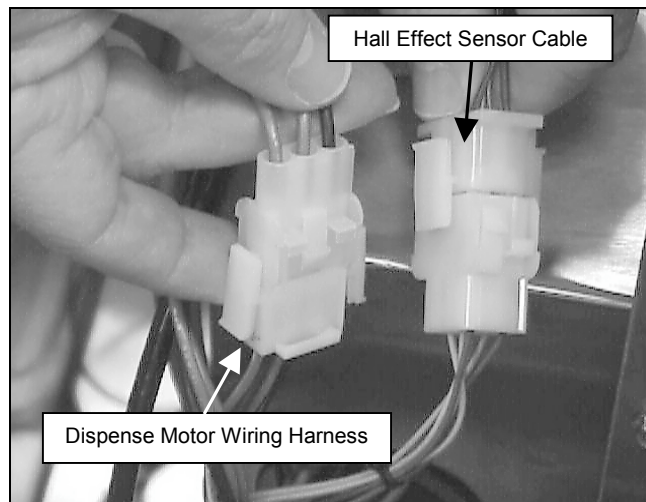

- Remove the basket alignment rack from the dispensing well. Remove the two bolts securing the dispense motor to the load cell arms (see illustration at right). Be ready to support the approximate 6-pound/3-kilogram weight of the dispense motor assembly when the bolts are removed.
- Carefully pull the dispense motor assembly out through the opening in the cabinet.
- Remove the setscrew securing the dispense door arm to the motor shaft and slip the arm from the shaft, being careful not to lose the square key. Remove the four Keps nuts from the screws securing the motor assembly to the dispense motor bracket.

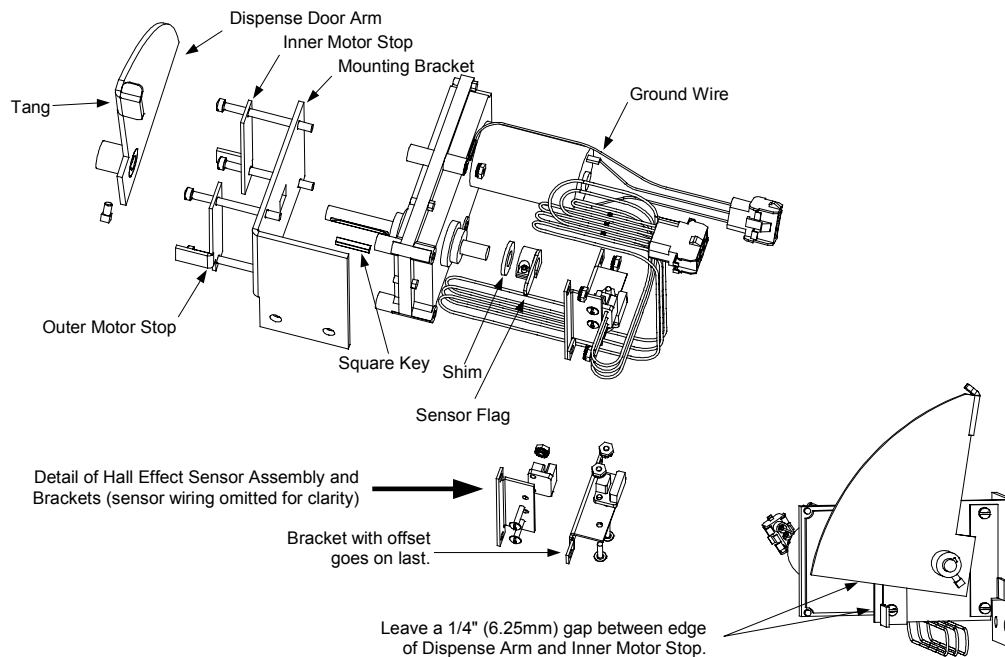
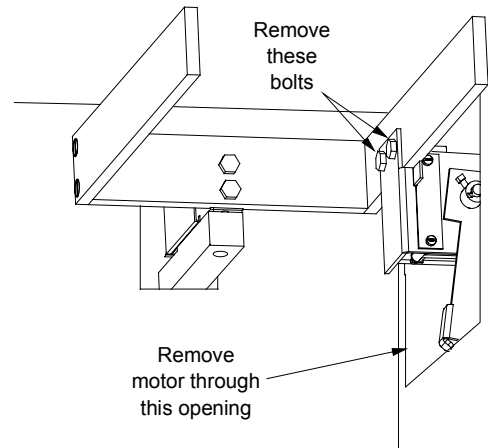

- Loosen the setscrew securing the sensor flag to the motor shaft and slide the flag and shim (spacer) from the shaft.
- Slip the Hall Effect sensor brackets off the mounting screws and separate the motor and mounting bracket.
- Assemble the replacement motor to the bracket then replace the Hall Effect sensor brackets, installing the bracket with offset last (see illustration in step 5). Replace and tighten the four Keps nuts, torquing to 5-10 inches/pound. **NOTE:** Ensure the ground wire is reattached to the upper right hand mounting screw.
- Insert the square key into the groove in the long motor shaft, align the slot in the dispense arm hub with the square key, and slip the arm onto the shaft with the hub on the outside (see illustration in step 5). **NOTE:** The door must be positioned between the motor stops (rotate the shaft, if necessary) and there must be at least $\frac{5}{16}$ " (8mm) clearance between the door and the motor. Torque the setscrew to 20-25 inches/pound.

10. Slip the shim (spacer) onto the short motor shaft, followed by the sensor flag (with the hub facing the shim). Rotate the dispense arm so that the tang is pointed up (see illustration in step 3) and there is a gap of approximately ¼” (6.25mm) between the edge and the inner motor stop.
11. Remove any slack in the motor shaft by placing the arm end on a work surface and gently pressing down on the motor. At the same time, rotate the sensor flag so that it is positioned between the faces of the upper (left) Hall Effect sensor. Verify that there is a gap of approximately ¼” (6.25mm) between the arm and the inner motor stop, then tighten the setscrew, torquing to 12 inches/pound.
12. Reinstall the dispense motor assembly by reversing steps 1 through 4.

2.2.4 Replacing the Drum Motor

1. Disconnect the unit from the electrical power source.
2. Disconnect the drum motor wiring from the drum motor cable (see illustration at right).
NOTE: The drum motor cable plugs into the motor interface board and the motor wiring plugs into it. It is not necessary to disconnect the drum motor cable from the motor interface board.
3. Remove the four Keps nuts (see illustration at right) that secure the drum motor to the drum motor bracket and pull the motor straight back off the mounting screws.
4. Grasp the motor shaft with a pair of locking pliers and unscrew the rotator arm (“bullet”) from the motor shaft and transfer it to the new motor.
5. Slip the new motor over the four mounting screws, being careful not to dislodge the screws. Replace and tighten the Keps nuts.
6. Reverse steps 1 and 2 to complete the procedure.

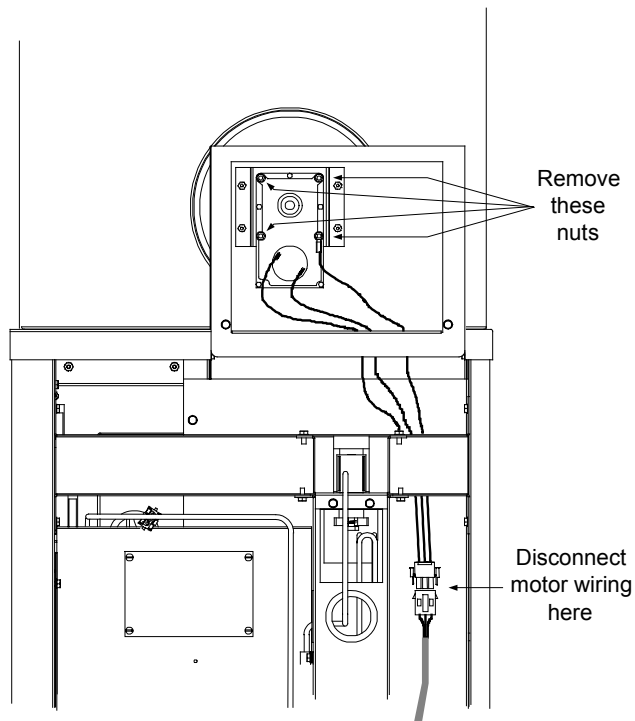

2.2.5 Replacing the Transformer or Line Filter

1. Disconnect the unit from the electrical power source.
2. Holding the new component next to the component being replaced, disconnect each wire from the old component and connect it to the new component, one at a time.
3. Remove the screws securing the old component to the mounting bracket, remove the old component, and install the new component.
4. Reconnect the unit to the electrical power source.

2.2.6 Replacing the Proximity Sensor

1. Disconnect the unit from the electrical power source.
2. Unplug the proximity sensor from the controller.
3. Unscrew the failed sensor from the block. Thread the stop nut on the replacement sensor back toward the cord-end until approximately ½ inch (12.5mm) of threads remain. Carefully screw the replacement sensor into the Teflon block until it is finger tight. Tighten the stop nut against cabinet.
4. Plug the sensor cable into jack J5 on the controller and reconnect the unit to the electrical power source.

2.2.7 Replacing the Motor Interface Board

1. Disconnect the unit from the electrical power source.
2. Holding the new interface board next to the one being replaced, disconnect each cable from the failed interface board and connect it to the new board, one at a time.
3. Remove the four Keps nuts securing the old board to its mounting and slip it off the mounting studs, being careful not to dislodge the spacers behind the board. Slip the new board onto the mounting studs and replace the Keps nuts.
4. Reconnect the unit to the electrical power source.

SinBaD II SINGLE BASKET DISPENSER

CHAPTER 3: PARTS LIST

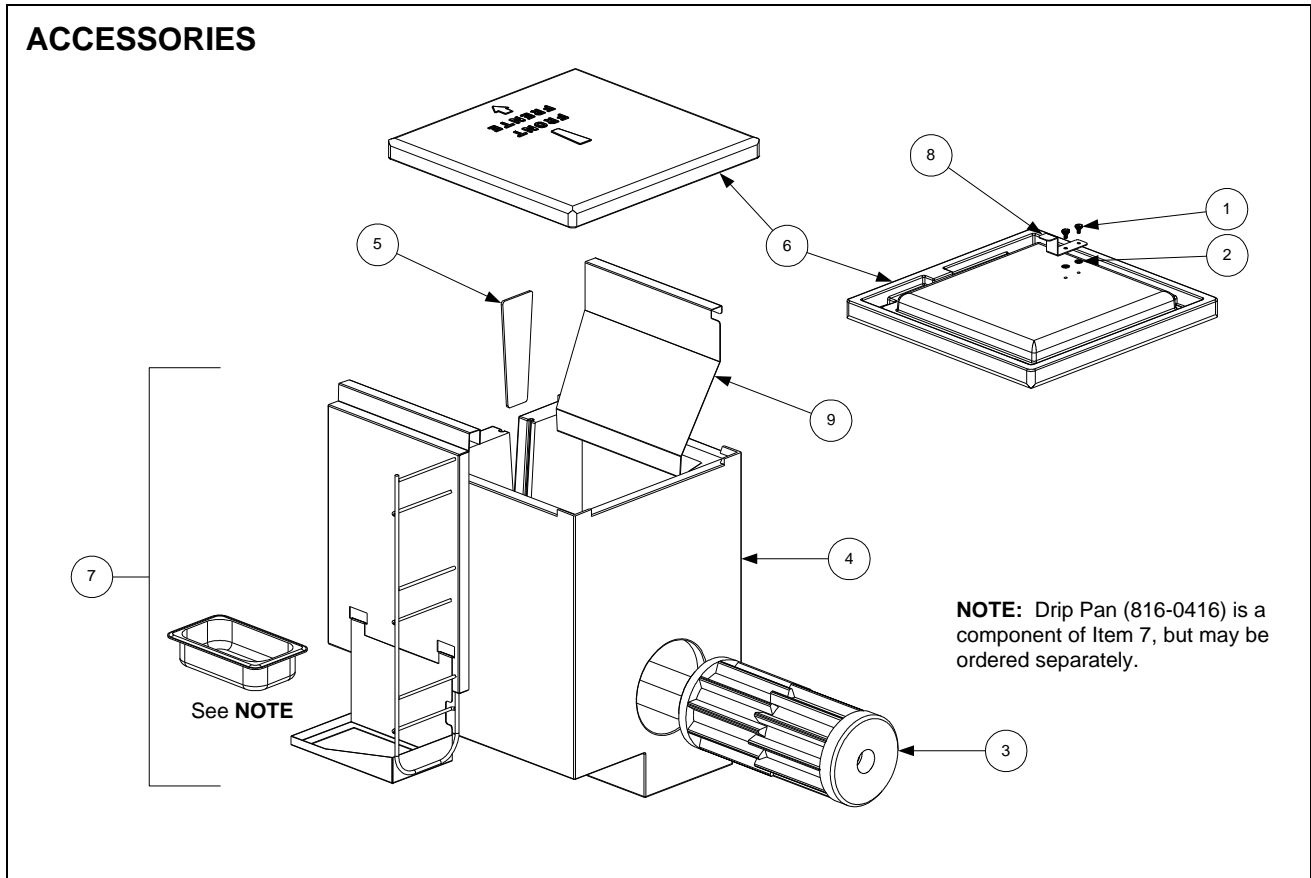

ITEM	PART #	COMPONENT
1	809-0747	Thumbscrew, 1/4-20 X ? -inch
2	809-0899	Retainer, 1/4-20
3	816-0378	Drum Hopper
4	816-0412	Hopper
5	816-0568	Sight Glass
*	826-1737	Kit, Sight Glass and Lanyard (has no index marks)
6	816-0491	Lid, Hopper
7	826-1592	Kit, Optional Basket Hanger (includes drip pan 816-0416)
8	910-7920	Handle, Hopper Lid
9	910-8688	Deflector

* Not illustrated.

CABINETRY

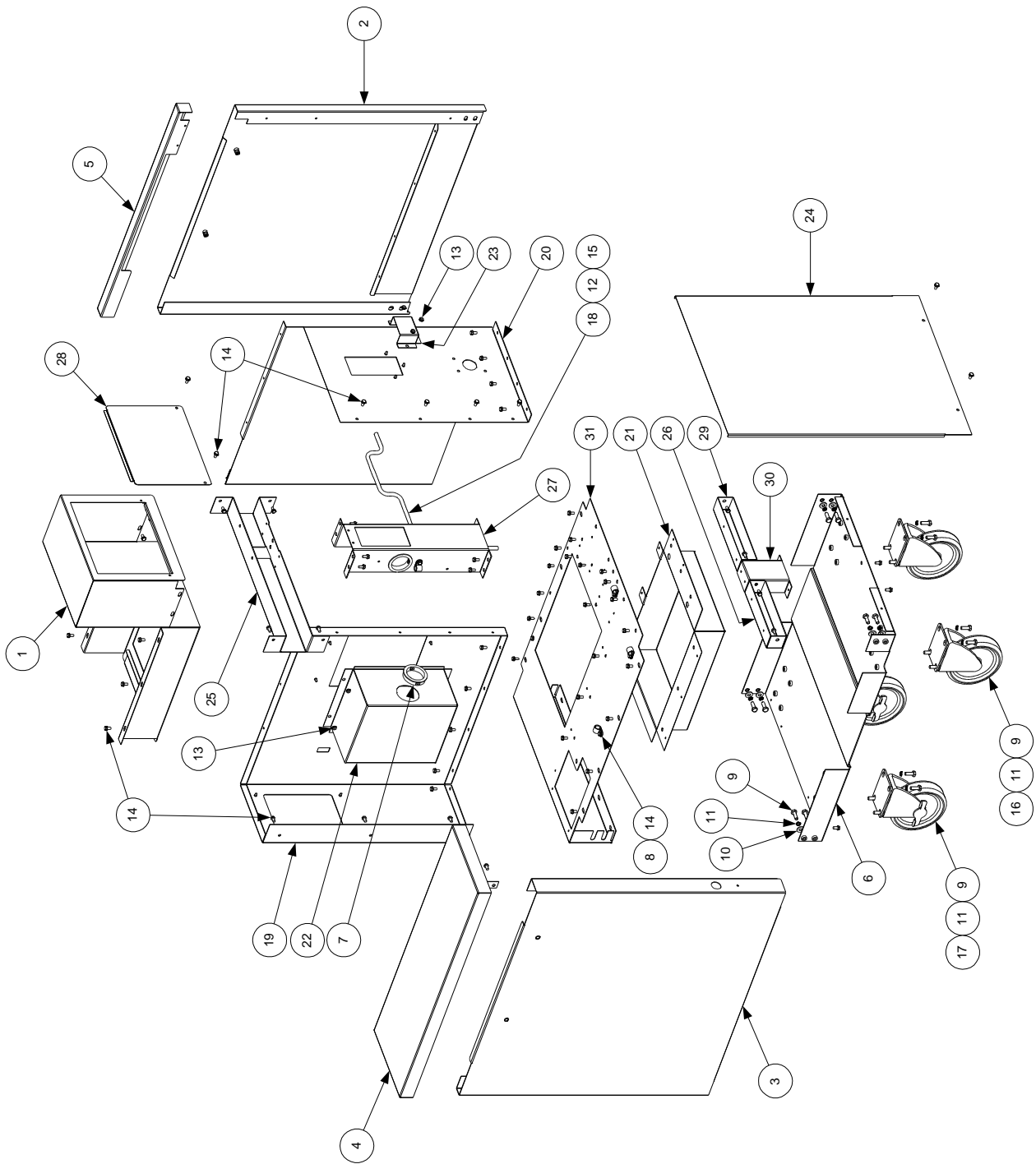

ITEM	PART #	COMPONENT
*	106-1382	Cabinet Assembly (Non-CE; <u>does not</u> include Items 2, 3, 16, 17, or 25)
*	106-1383	Cabinet Assembly (CE; <u>does not</u> include Items 2, 3, 16, 17, or 25)
1	106-0643	Cover Assembly, Drum Motor
2	910-8209	Side, Cabinet Left (included with 106-1382 or 106-1383)
3	910-8219	Side, Cabinet Right (included with 106-1382 or 106-1383)
4	806-9228	Cover, Right Cabinet Top
5	806-9235	Cover, Left Cabinet Top
6	806-9782	Base Assembly
7	807-1083	Bushing, Heyco
8	809-0037	Clamp, Plastic Wire
9	809-0131	Screw, 1/4-20 X 3/4-inch Hex Head
10	809-0189	Washer, 1/4-inch SAE Plane S/S
11	809-0191	Washer, 1/4-inch Lock
12	809-0194	Washer, Flat 5/16-inch SAE
13	809-0250	Nut, 6-32 Keps Hex
14	809-0434	Screw, #10 X ? -inch Hex Washer Head
15	809-0783	Nut, 5/16-18 Nylon Hex Lock
16		Caster w/o Brake
	810-0356	5-inch
	810-0949	2 1/2-inch
17		Caster w/Brake
	810-0357	5-inch
	810-1735	2 1/2-inch
18	810-1644	Guide, Basket
19	823-2761	Panel, Front
20	823-2864	Liner, Inner (CE, Non-CE)
21	824-0744	Catcher, Fry
22	824-0752	Cover, Dispense Motor
23	824-0771	Cover, Load Cell Hole
24	900-8208	Cover, Back
25	900-8211	Brace, Upper Back
26	900-8223	Brace, Lower Back (Right)
27	900-8224	Brace, Load Cell Vertical
28	900-8324	Panel, Motor Access
29	900-8352	Brace, Lower Back (Left)
30	900-9440	Support, Base
31	910-8990	Liner, Bottom

* Not illustrated.

DISPENSE SYSTEM COMPONENTS

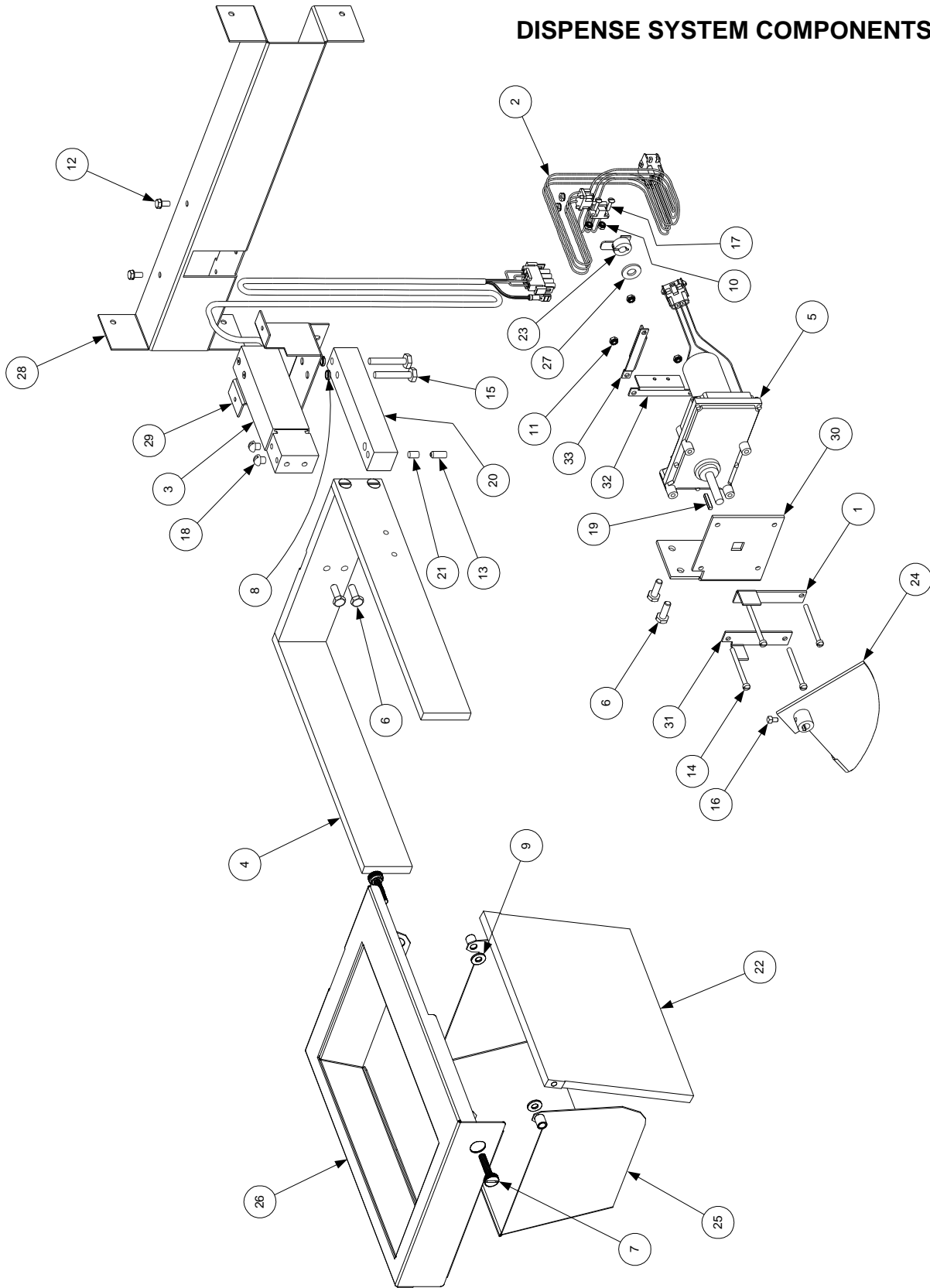

ITEM	PART #	COMPONENT
1	210-0810	Stop, Door Open Position
2	806-8969SP	Switch Assembly, Position (Hall Effect Sensor)
3	806-9258	Load Cell Assembly
4	806-9271	Load Cell Arm Assembly
5	807-3004	Motor, 24VDC Dispense
6	826-1389	Screw, ¼-20 x ¾-inch Hex Head (Pkg. of 10)
7	809-0171	Thumbscrew, ¼-20 x 1? -inch
8	809-0191	Washer, ¼-inch Lock
9	809-0193	Washer, ¼-inch Nylon Flat
10	826-1366	Nut, 4-40 Keps Hex (Pkg. of 25)
11	809-0247	Nut, 8-32 Keps Hex
12	809-0434	Screw, #10 x ? -inch Hex Washer Head
13	809-0480	Setscrew, ¼-28 x 5/8-inch
14	809-0613	Screw, 8-32 x 2-inch Fillister Head
15	809-0649	Bolt, ¼-20 x 1½-inch
16	809-0674	Setscrew, 8-32 x ? -inch Cup Point Square Head
17	809-0675	Screw, 4-40 x ½-inch Slotted Pan Head
18	809-0737	Screw, ¼-20 x ¼-inch Slotted Round Head Cap
19	810-1391	Key, ? -inch x ¾-inch
20	810-1770	Brace, Load Cell
21	810-1771	Rod, ¼-inch x ? -inch Aluminum
22	816-0400	Door, Dispense Chute
23	823-2607	Flag, Door Position (Hall Effect Sensor Flag)
24	823-2670	Arm, Dispense Door
25	823-2717	Chute, Dispense (see NOTE below)
26	823-3412	Top, Dispense Chute
27	900-8169	Shim, Motor Shaft
28	900-8211	Brace, Upper Back
29	900-8233	Saddle, Load Cell
30	910-5855	Bracket, Dispense Motor
31	910-7950	Stop, Door Closed Position
32	910-8164	Bracket, Lower Position Switch (Lower Hall Effect Sensor Bracket)
33	910-8165	Bracket, Upper Position Switch (Upper Hall Effect Sensor Bracket)
*	810-1675	Shim, Load Cell (used for transport only)
*	806-9272	Shipping Screw Assembly, Load Cell (used for transport only)

* Not illustrated.

NOTE: Use P/N 106-1529SP to order a complete dispense chute assembly (Items 7, 9, 22, 25, and 26).

DRUM MOTOR COMPONENTS

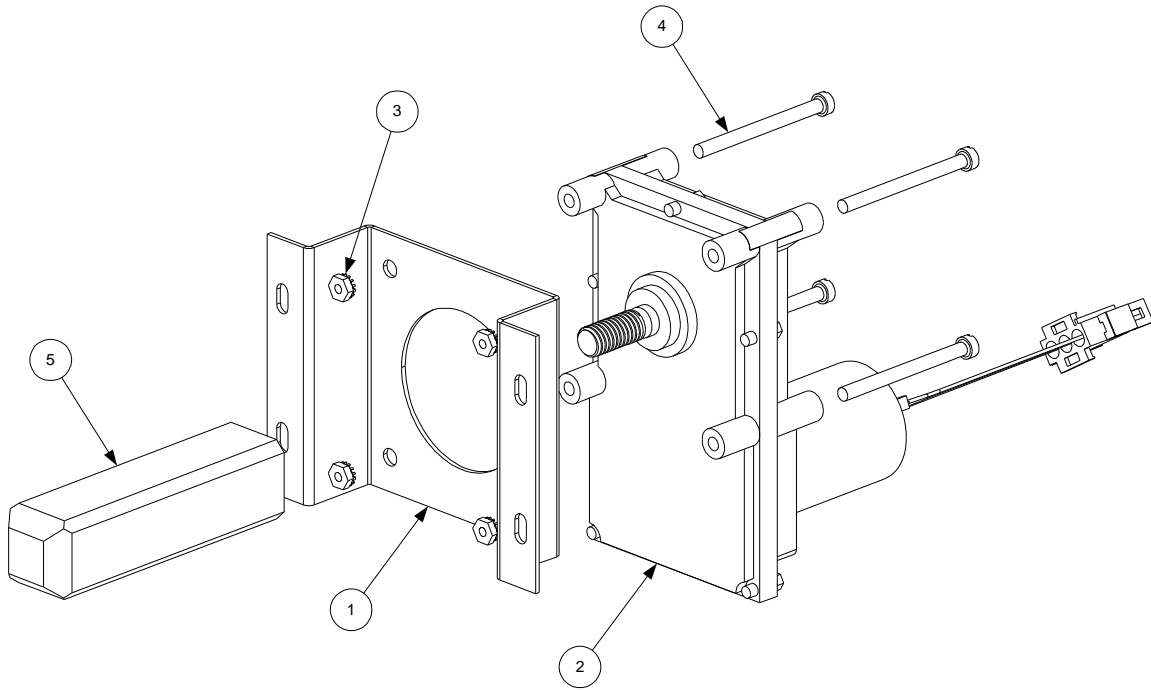

ITEM	PART #	COMPONENT
1	200-0953	Bracket, Drum Motor
2	807-3436	Drum Motor (for complete assembly (items 1-5), use 806-9326SP)
3	809-0247	Nut, 8-32 Keps
4	809-0613	Screw, 8-32 X 2-inch Fillister Head
5	810-1571	Arm, Drum Rotator ("Bullet")

ELECTRONICS

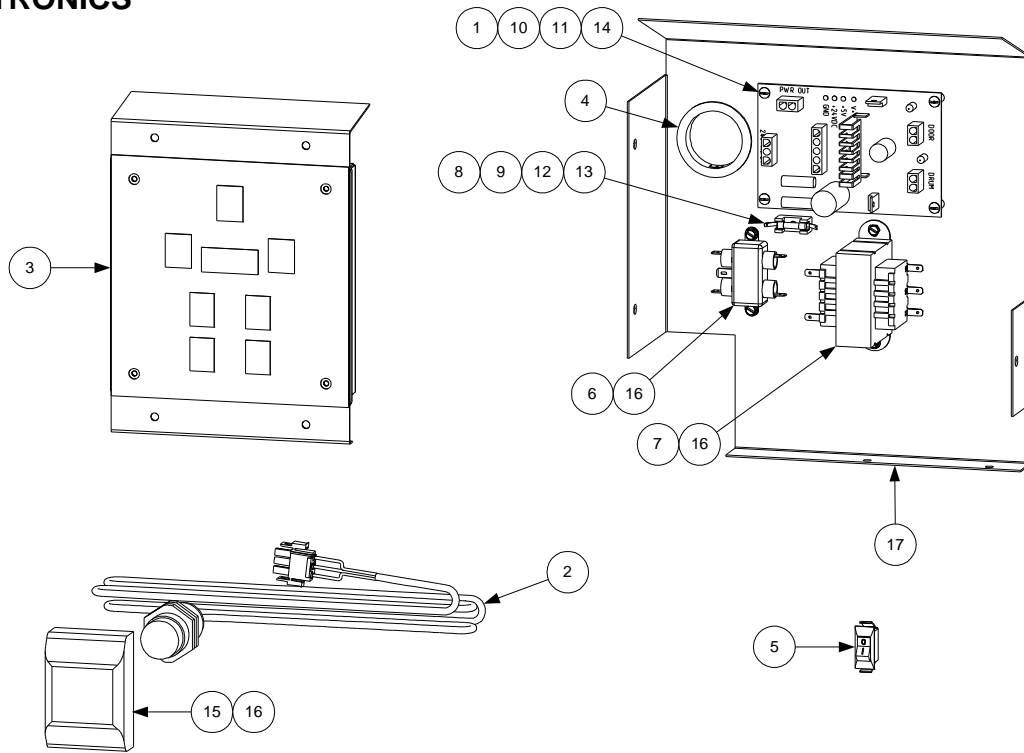

ITEM	PART #	COMPONENT
1	106-0242	Interface Board
2	106-0503SP	Switch Assembly, Proximity
3	106-1277	Computer Assembly
4	807-1083	Bushing, 2-Inch Nylon
5	807-2734	Switch, ON/OFF, Illuminating, Green
6	807-2818	Filter, 120-250VAC Line
7		Transformer
	807-2943	115/230V-24V
	807-3185	230V-24V (Used on CE units only)
8	807-3127	Fuse Holder (Used on CE units only)
9	807-3128	Fuse (Used on CE units only)
10	809-0097	Screw, 6-32 x 1-inch Slotted Truss Head
11	809-0250	Nut, 6-32 Keps Hex
12	809-0669	Screw, #3-48 Rd Hd 18-8 SS (Used on CE units only)
13	809-0670	Nut, #3-48 Hex Hd 18-8 SS (Used on CE units only)
14	810-0383	Spacer, Nylon
15	816-0566	Block, Proximity Switch
16	826-1371	Screw, #8 X 1/2-inch Hex Hd Drill Point (Pkg. of 25)
17	900-8938	Bracket, Electronic Components Mounting
*	826-1605	Kit, Computer Gasket

* Not illustrated.

WIRING

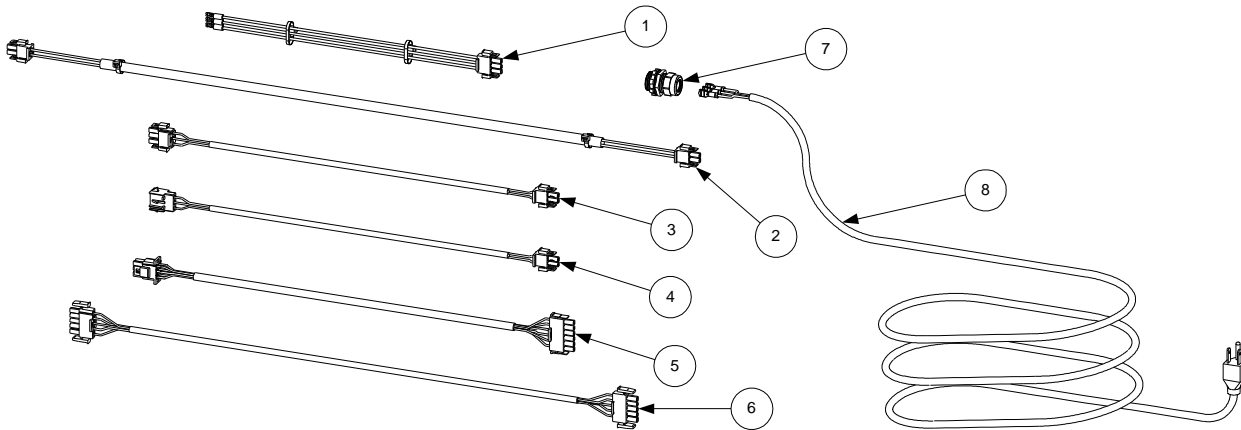

ITEM	PART #	COMPONENT
1	806-8956	Cable, Transformer to Interface Board
2	806-8957	Cable, Computer/Interface Board 12VDC Power
3	807-2912	Cable, Dispense Motor to Computer Terminal J5
4	807-2915	Cable, Drum Motor to Computer Terminal J4
5	807-3056	Cable, Position (Hall-effect) Switch to Interface Board Terminal J8
6	807-3058	Cable, Computer/Interface Board Signal
7		Strain Relief, Power Cord
	807-3240	Non-CE (for use with Power Cords 806-8889 and 806-9251)
	807-3287	CE (for use with Power Cord 806-9886)
8		Power Cord
	806-8889	120VAC w/strain relief and plug (Non-CE)
	806-9251	100-450VAC (#16, 18 amp, w/strain relief, w/o plug) (Non-CE Export)
	806-9886	230VAC w/strain relief and plug (CE)



Frymaster, L.L.C., 8700 Line Avenue, PO Box 51000, Shreveport, Louisiana 71135-1000
Shipping Address: 8700 Line Avenue, Shreveport, Louisiana 71106

TEL 1-318-865-1711

FAX (Parts) 1-318-219-7140

(Tech Support) 1-318-219-7135

PRINTED IN THE UNITED STATES

SERVICE HOTLINE
1-800-551-8633

Price: \$8.00
[819-5875](tel:819-5875)
MARCH 2005