

Frymaster[®]

Your Growth Is Our Goal

Pro H55-Series Gas Fryer

Service and Parts Manual

This manual is updated as new information and models are released. Visit our website for the latest manual.



Part Number: FRY_SP_8196083 01/2024

Original Instructions



NOTICE

IF, DURING THE WARRANTY PERIOD, THE CUSTOMER USES A PART FOR THIS FRYMASTER DEAN EQUIPMENT OTHER THAN AN UNMODIFIED NEW OR RECYCLED PART PURCHASED DIRECTLY FROM FRYMASTER DEAN, OR ANY OF ITS AUTHORIZED SERVICERS, AND/OR THE PART BEING USED IS MODIFIED FROM ITS ORIGINAL CONFIGURATION, THIS WARRANTY WILL BE VOID. FURTHER, FRYMASTER DEAN AND ITS AFFILIATES WILL NOT BE LIABLE FOR ANY CLAIMS, DAMAGES OR EXPENSES INCURRED BY THE CUSTOMER WHICH ARISE DIRECTLY OR INDIRECTLY, IN WHOLE OR IN PART, DUE TO THE INSTALLATION OF ANY MODIFIED PART AND/OR PART RECEIVED FROM AN UNAUTHORIZED SERVICE CENTER.

NOTICE

This appliance is intended for professional use only and is to be operated by qualified personnel only. A Frymaster Factory Authorized Servicer (FAS) or other qualified professional should perform installation, maintenance, and repairs. Installation, maintenance, or repairs by unqualified personnel may void the manufacturer's warranty.

NOTICE

This equipment must be installed in accordance with the appropriate national and local codes of the country and/or region in which the appliance is installed.

NOTICE TO U.S. CUSTOMERS

This equipment is to be installed in compliance with the basic plumbing code of the Building Officials and Code Administrators International, Inc. (BOCA) and the Food Service Sanitation Manual of the U.S. Food and Drug Administration.

 **DANGER**

Instructions to be followed in the event the operator smells gas or otherwise detects a gas leak must be posted in a prominent location. This information can be obtained from the local gas company or gas supplier.

 **WARNING**

Improper installation, adjustment, alteration, service or maintenance can cause property damage, injury, or death. Read the installation, operating, and maintenance instructions thoroughly before installing or servicing this equipment. Only qualified service personnel may convert this appliance to use a gas other than that for which it was originally configured.

 **FOR YOUR SAFETY**

Do not store or use gasoline or other flammable liquids or vapors in the vicinity of this or any other appliance.

 **DANGER**

The front ledge of the fryer is not a step! Do not stand on the fryer. Serious injury can result from slips or contact with the hot oil.

 **DANGER**

No structural material on the fryer should be altered or removed to accommodate placement of the fryer under a hood. Questions? Call the Frymaster Dean Service Hotline at 1-800-551-8633.

NOTICE

Drawings and photos used in this manual are intended to illustrate operational, cleaning and technical procedures and may not conform to onsite management operational procedures.

NOTICE TO OWNERS OF UNITS EQUIPPED WITH COMPUTERS

U.S.

This device complies with Part 15 of the FCC rules. Operation is subject to the following two conditions: 1) This device may not cause harmful interference, and 2) This device must accept any interference received, including interference that may cause undesired operation. While this device is a verified Class A device, it has been shown to meet the Class B limits.

CANADA

This digital apparatus does not exceed the Class A or B limits for radio noise emissions as set out by the ICES-003 standard of the Canadian Department of Communications.

Cet appareil numérique n'émet pas de bruits radioélectriques dépassant les limites de classe A et B prescrites dans la norme NMB-003 édictée par le Ministre des Communications du Canada.

DANGER

Do not spray aerosols in the vicinity of this appliance while it is in operation.

DANGER

The crumb tray in fryers equipped with a filter system must be emptied into a fireproof container at the end of frying operations each day. Some food particles can spontaneously combust if left soaking in certain shortening material.

WARNING

Do not bang fry baskets or other utensils on the fryer's joiner strip. The strip is present to seal the joint between the fry vessels. Banging fry baskets on the strip to dislodge shortening will distort the strip, adversely affecting its fit. It is designed for a tight fit and should only be removed for cleaning.

NOTICE

The Commonwealth of Massachusetts requires any and all gas products to be installed by a licensed plumber or pipe fitter.

WARNING

This appliance is not intended for use by children under the age of 16 or persons with reduced physical, sensory or mental capabilities, or lack of experience and knowledge, unless they have been given supervision concerning use of the appliance by a person responsible for their safety. Do not allow children to play with this appliance.

WARNING

After installation of a gas fryer and after any maintenance to the gas system of a gas fryer-manifold, valve, burners, etc. – check for gas leaks at all connections. Apply a thick soapy solution to all connections and ensure there are no bubbles. There should be no smell of gas.

DANGER

When installed, this appliance must be electrically grounded in accordance with local codes, or in the absence of local codes, with the National Electrical Code, ANSI/NFPA 70, the Canadian Electrical Code, CSA C22.2 as applicable.

DANGER

When installed, this appliance must conform with local codes, or in the absence of local codes, with the National Fuel Gas Code, ANSI Z223.1/NFPA54, or the Natural Gas and Propane Installation Code, CSA B149.1 as applicable or the appropriate national code of the country in which installed.

NOTICE

The appliance must be installed and used in such a way that any water cannot contact the fat or oil.

⚠ WARNING

If the electrical power supply cord is damaged, it must be replaced by a Frymaster Factory Authorized Servicer or a similarly qualified person in order to avoid a hazard.

⚠ DANGER

Adequate means must be provided to limit the movement of the appliance without depending upon the gas line connector and the quick-disconnect device or its associated piping to limit the appliance movement.

All fryers equipped with casters must be stabilized by installing restraining chains. If a flexible gas line is used, an additional restraining cable must be connected at all times when the fryer is in use.

All fryers equipped with casters must be installed using a connector that complies with the Standard for Connectors for Moveable Gas Appliances, ANSI Z21.69 or CSA 6.16, and a quick-disconnect device that complies with the Standard for Quick-Disconnect Devices for Use with Gas Fuel, ANSI Z21.41 or CSA 6.9.

NOTICE

This appliance is intended to be used for commercial applications, for example in kitchens of restaurants, canteens, hospitals and in commercial enterprises such as bakeries, butcheries, etc., but not for continuous mass production of food.

⚠ DANGER

This appliance must be connected to a power supply having the same voltage and phase as specified on the rating plate located on the inside of the appliance door.

⚠ WARNING

Use caution and wear appropriate safety equipment to avoid contact with hot oil or surfaces that may cause severe burns or injury.

⚠ WARNING

Do not block the area around the base or under the fryers.

⚠ WARNING

Operation, installation, and servicing of this product may expose you to chemicals/products including [Bisphenol A (BPA), glass wool or ceramic fibers, and crystalline silica], which is [are] known to the State of California to cause cancer, birth defects or other reproductive harm. For more information go to www.P65Warnings.ca.gov.

PRO H50/55-SERIES GAS FRYERS

TABLE OF CONTENTS

CHAPTER 1: Service Procedures

1.1	Functional Description	1-1
1.1.1	The Electronic Ignition System	1-1
1.1.2	Interface Board	1-2
1.1.3	Thermostats	1-4
1.2	Accessing Fryers for Servicing	1-4
1.3	Cleaning the Gas Valve Vent Tube	1-5
1.4	Checking the Burner Manifold Gas Pressure	1-5
1.5	Measuring Flame Current	1-7
1.6	Replacing Fryer Components	1-7
1.6.1	Replacing the Controller or the Controller Wiring Harness	1-7
1.6.2	Replacing the Temperature Probe or High-Limit Thermostat	1-8
1.6.3	Replacing the Interface Board	1-9
1.6.4	Replacing an Ignition Module	1-9
1.6.5	Replacing an Ignitor Assembly	1-10
1.6.6	Replacing or Cleaning a Combustion Air Blower	1-10
1.6.7	Replacing a Gas Valve	1-13
1.6.8	Replacing a Burner Assembly	1-14
1.6.9	Replacing the Filter Motor, Filter Pump, or Filter Pump Solenoid Valve	1-15
1.6.10	Replacing the Frypot	1-16
1.6.11	Replacing Frypot Insulation and/or Upper Burner Rails	1-18
1.7	Troubleshooting and Problem Isolation	1-23
1.7.1	Ignition Failure	1-23
1.7.2	Improper Burner Function	1-24
1.7.3	Improper Temperature Control	1-26
1.7.4	Computer Malfunctions	1-26
1.7.5	Filtration Malfunctions	1-27
1.7.6	Leakage	1-29
1.7.7	Basket Lift Malfunctions	1-29
1.7.8	Interpretation of Digital Controller Lights	1-31
1.8	Troubleshooting Guides	1-31
1.8.1	Troubleshooting the 24 VAC Circuit	1-31
1.8.2	Troubleshooting the Gas Valve	1-35
1.8.3	Troubleshooting the Temperature Probe	1-35
1.8.4	Probe Resistance Chart	1-36
1.9	Simplified Wiring Diagrams	1-37
1.9.1	Full-Vat Dual-Spark Module Wiring Diagram	1-37
1.9.2	Full-Vat Single-Spark Module Wiring Diagram (Australia & Pacific Rim)	1-38
1.9.3	Dual-Vat Dual-Spark Module Wiring Diagram	1-39
1.10	Principal Wiring Connections	1-40
1.11	Wiring Diagrams	1-41
1.11.1	Pro H50/55-Series Fryer, Multi-vat, Honeywell	1-41
1.11.1.2	Pro H50/55-Series Fryer, Multi-vat, Fenwal	1-42
1.11.2	Pro H50/55-Series Fryer, Single, Full-vat, Honeywell	1-43
1.11.2.1	Pro H50/55-Series Fryer, Single, Full-vat, Fenwal	1-44
1.11.3	Pro H50/55-Series Fryer, Single, Dual-vat, Honeywell	1-45
1.11.3.1	Pro H50/55-Series Fryer, Single, Dual-vat, Fenwal	1-46
1.11.4	Pro H50/55-Series Fryer, Single, CE, Honeywell	1-47
1.11.4.1	Pro H50/55-Series Fryer, Single, CE, Fenwal	1-48
1.11.4.2	Pro H50/55-Series Fryer, Multi-vat, CE, Fenwal	1-49
1.11.5	Pro H50/55-Series Fryer, Single, FAST-ready, Honeywell	1-50

PRO H50/55-SERIES GAS FRYERS TABLE OF CONTENTS

1.11.5.1	Pro H50/55-Single w/out Filter, FAST-ready, Fenwal.....	1-51
1.11.5.2	Pro H50/55-Single w/Filter, FAST-ready, Fenwal.....	1-52
1.11.5.3	Pro H50/55-Multi-vat, FAST-ready, Fenwal	1-53
1.11.5.4	Pro H50/55-Single w/out Filter, FAST-ready, CE, Fenwal.....	1-54
1.11.5.5	Pro H50/55-Single w/Filter, FAST-ready, CE, Fenwal.....	1-55
1.11.5.6	Pro H50/55-Multi-vat, FAST-ready, CE, Fenwal	1-56
1.11.6	Pro H50/55-Series Fryer, Multi-vat Australia	1-57
1.11.7	Pro H50/55-Series Fryer, Single, Australia	1-58
1.11.8	Transformer/Filter Boxes	1-59
1.11.8.1	MPH150/155 Transformer/Filter Box.....	1-59
1.11.8.2	FPH150/155 Transformer/Filter Box	1-59
1.11.8.3	FPPH250/255/450/455 Transformer/Filter Box.....	1-60
1.11.8.4	FPPH350/355 Transformer/Filter Box	1-61
1.11.9	Modular Basket Lift -100/120V- (<i>Prior to Jan. 2023</i>)	1-62
1.11.10	Modular Basket Lift - 208/250V- (<i>After Feb. 2002</i>)	1-63
1.11.11	Modular Basket Lift - H55/H155 - 120V- (<i>After Jan. 2023</i>).....	1-64
1.11.12	Modular Basket Lift - H55/H155 - 208/250V- (<i>After Jan. 2013</i>).....	1-65
1.11.13	Oil Return/Disposal.....	1-66

CHAPTER 2: Parts List.....		
2.1	Accessories	2-1
2.2	Basket Lift Assemblies and Component Parts	2-2
2.2.1	Basket Lift Assemblies and Component Parts - (<i>June 1997 to April 2012</i>)	2-2
2.2.2	Basket Lift Assemblies and Component Parts - H55/H155 - 120V- (<i>After April 2012</i>)	2-4
2.2.3	Basket Lift Assemblies and Component Parts - H55/H155 - 208-250V- (<i>After April 2022</i>)	2-6
2.3	Cabinetry.....	2-8
2.3.1	Backs, Doors, Flue Caps, Sides, and Top Caps.....	2-8
2.3.2	Filter Cabinet Bases, Casters, Framing, and Related Components	2-10
2.3.3	Non-Filter Cabinet Bases, Casters, Framing, and Related Components	2-12
2.4	Controllers.....	2-14
2.5	Drain, Filtration, and Oil Return System Components	2-15
2.5.1	Filtration System Components	2-15
2.5.2	Drain Valves and Associated Components	2-17
2.5.3	Oil Return Line Components	2-19
2.5.4	Oil Return Handle, Oil Disposal and Disposal Hose Components.....	2-21
2.5.5	Oil Disposal Wand Assembly	2-23
2.5.6	Assembly Wand Plumbing.....	2-23
2.5.7	Rear Flush Oil Return Components	2-24
2.5.8	Power Shower Assemblies	2-26
2.6	Electronics and Electrical Components.....	2-27
2.6.1	Component Boxes	2-27
2.6.2	Transformer Boxes.....	2-29
2.6.3	High-Limit Thermostat and Temperature Probe	2-31
2.7	Frypots and Associated Components	2-32
2.7.1	Full-Vat Frypot Components	2-32
2.7.2	Dual-Vat Frypot Components	2-34
2.8	Gas Supply and Combustion System Components	2-36
2.9	Gas Valves and Associated Components	2-38
2.9.1	Gas Valve Wiring.....	2-39
2.10	Wiring Assemblies and Harnesses	2-40

**PRO H50/55-SERIES GAS FRYERS
TABLE OF CONTENTS**

2.11 Miscellaneous Connectors and Terminals..... 2-42

CHAPTER 3: Single H50/55 Unit Unique Parts List

3.1 Filtration System Components 3-1
3.2 Oil Return Components..... 3-2
3.3 Component Boxes 3-3
3.4 High-Limit Thermostat and Temperature Probe 3-4
3.5 Transformer Boxes..... 3-5

PRO H50/55-SERIES GAS FRYERS

CHAPTER 1: SERVICE PROCEDURES

1.1 Functional Description

Pro (H50/55) Series gas fryers contain a welded stainless steel frypot that is directly heated by a high efficiency infrared burner system requiring approximately 43% less energy than conventional burners to cook the same volume.

Self-contained combustion chambers (referred to as “burners”) are fitted into rails attached to the sides of the frypot, one on each side. Each combustion chamber is fitted with special ceramic tiles that are heated by burning a forced air/gas mixture. The tiles transfer heat to the frypot by means of infrared radiation, providing much more constant and uniform heat dispersion over the surface of the frypot than conventional burners. Because less heat is lost to the atmosphere in the process, compared to “open-burner” designs, less fuel is required to achieve and maintain temperature.

In full-vat units, gas flow to both of the burners is regulated by one electromechanical gas valve. In dual-vat units, each burner has its own valve. All fryers in this series are equipped with 24 VAC gas valve systems and electronic ignition.

1.1.1 Electronic Ignition System

An ignition module mounted in the component box (located behind the control panel) is connected to an ignitor assembly at the burner. The ignition module performs four important functions: it provides fuse protection for the 24-volt circuit, provides an ignition spark, supplies voltage to the gas valve, and proofs the burner flame. The module contains a 4-second time delay circuit and a coil that activates the gas valve. Three types are in use. A closed-box design is used in most fryers, but in some fryers built for export, the module resembles an interface board. A single dual-spark module is used on current production full-vat fryers. All dual-vat fryers use two single-spark modules.

The ignitor assembly consists of a spark plug, an enrichment tube, and a flame sensor.

At start-up, the power switch is placed in the ON position, supplying approximately 12-volts DC to the heat-control circuitry in the controller or computer and to one side of the heat relay coils on the interface board. If resistance in the temperature probe indicates the temperature in the frypot is below 180°F (82°C), the current flows through a melt cycle circuit where a timer switch alternately closes for 6 seconds and opens for 24 seconds. If the temperature is 180°F (82°C) or above, the current flows through a heat circuit, bypassing the timer switch. In either case, ground is supplied to the other leg of the heat relay coils, which then close electronic switches in the 24 VAC circuit to provide current to the ignition module. Circuitry in the ignition module sends 24 VAC to the gas

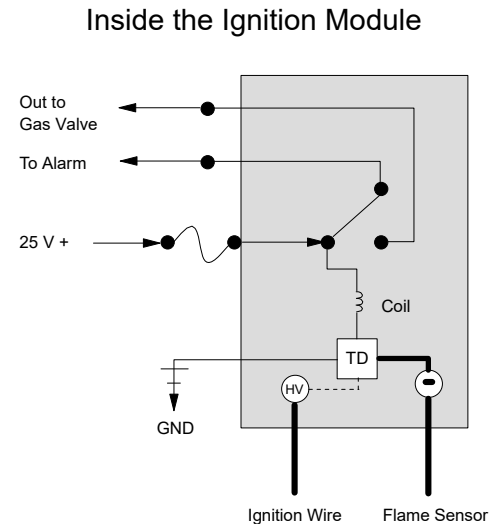

valve via a normally closed high-limit switch (and, in fryers with built-in filtration systems, a normally closed drain safety switch). Simultaneously, the module causes the ignitor to spark for 4 seconds to light the burner. A flame sensor verifies the burner ignition by measuring the flow of microamps through the flame. If the burner does not light (or is extinguished), current to the ignition module is cut, the gas valve closes, and the ignition module “locks out” until the power switch is turned off and then back on. A probe monitors the temperature in the frypot. When the programmed setpoint temperature is reached, resistance in the probe causes the heat cycle circuitry in the controller to cut off current flow through the heat relay. This in turn cuts off the 24 VAC to the ignition module, causing the gas valve to close.

1.1.2 Interface Board

The information contained in this section applies to Pro (H50/55) Series gas fryers ONLY.

All fryers in this series have an interface board located in the component box behind the control panel. The interface board provides a link between the controller/computer and the fryer’s individual components without requiring excessive wiring, and allows the controller to execute commands from one central point. This standard interface board is also used in a number of fryer types besides the Pro Series.

K2 and K3 are double-pole-double-throw (dpdt) relays that supply 24VAC to the ignition and gas valve circuits, as well as 120VAC to the blower motor. The relays on this board plug into sockets, and if either fails, it can be replaced individually.

LEDs (labeled D1 through D7) are arrayed around the board to assist in troubleshooting.

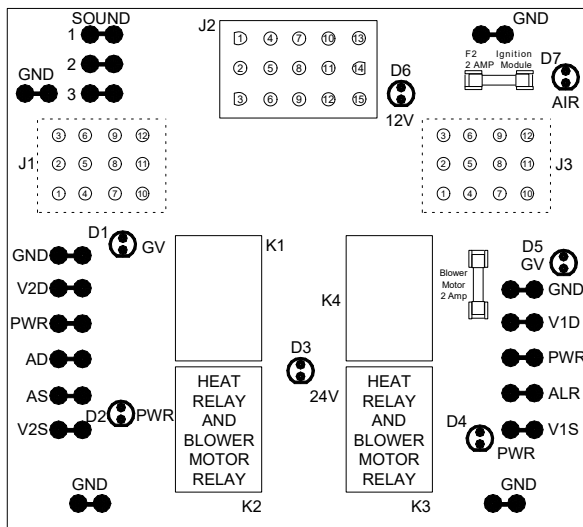

INTERFACE BOARD P/N 106-0386

INTERFACE BOARD LED DIAGNOSTIC LIGHTS	
D1	24 VAC to left gas valve (dual vat only)
D2	24 VAC to left ignition module
D3	24 VAC from transformer
D4	24 VAC to right ignition module
D5	24 VAC to gas valve (right valve if dual vat)
D6	12 VAC from transformer
D7	CE and Japanese units only: air switch closed

NOTE: Although the printing on some boards may indicate 2 Amp fuses, **3 Amp fuses (P/N 807-3843) must be used.** In full-vat fryers, the relay for the left side (K2) may not be present.

The chart on the following page illustrates current flow through the board, and the table at the top of page 1-4 identifies frequently used test points.

INTERFACE BOARD

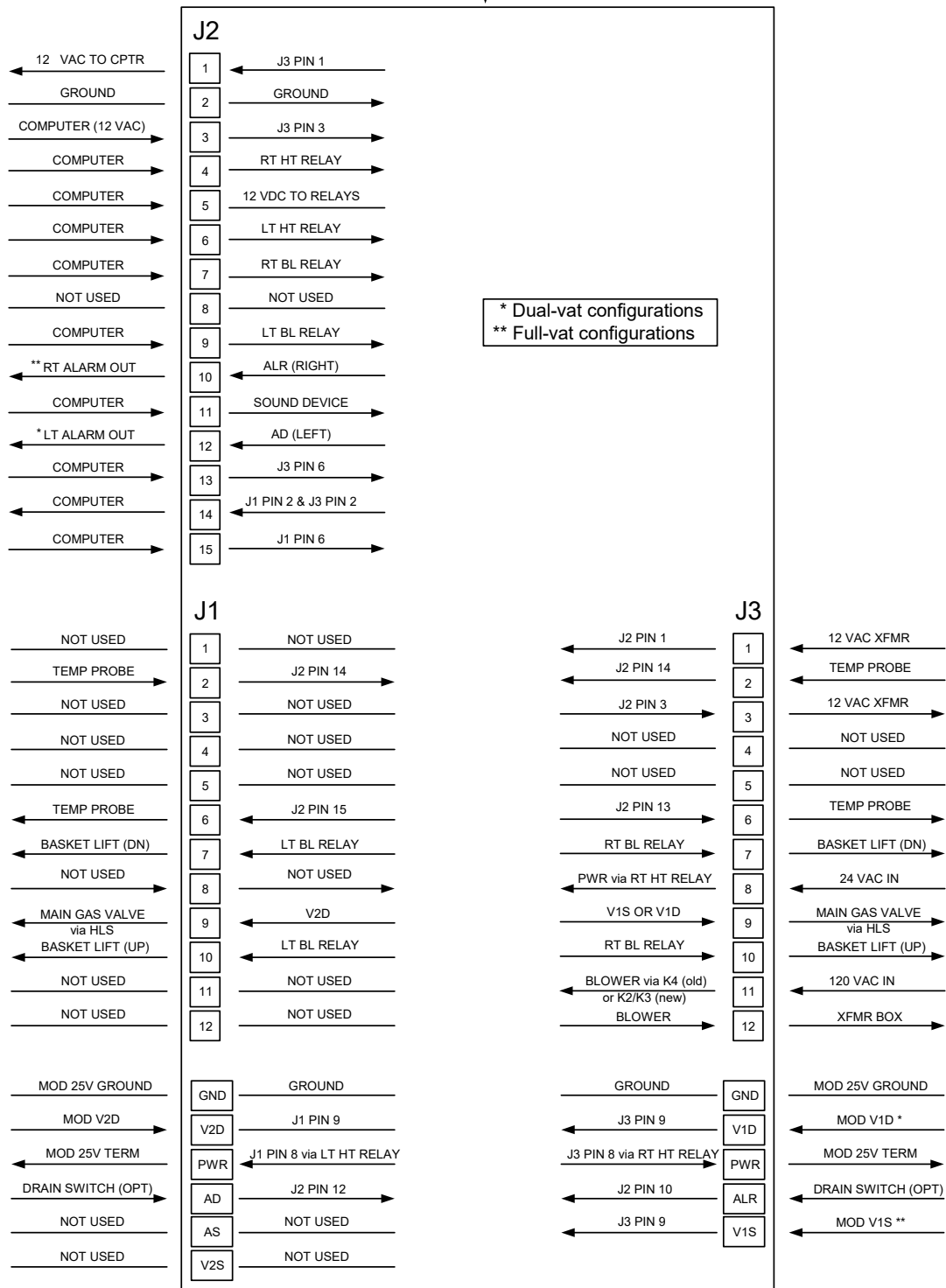

LEFT-VAT

FULL- OR RIGHT- VAT

CURRENT FLOW THROUGH INTERFACE BOARD 106-0386 (PRO SERIES APPLICATION)

FREQUENTLY USED TEST POINTS FOR INTERFACE BOARD 106-0386			
TEST	METER SETTING	PINS	RESULTS
12VAC Power to Controller	50VAC Scale	1 and 3 on J3 or J2	12-18
24VAC Power to Right Module	50VAC Scale	8 on J3 and GROUND	22-28
120 VAC Power	250VAC Scale	11 on J3 and GROUND	110-125
120 VAC Power to Blowers	250VAC Scale	12 on J3 and GROUND	110-125
24VAC Power to Full or Right vat High-Limit	50VAC Scale	9 on J3 and GROUND	22-28
24VAC Power to Left High-Limit (if present)	50VAC Scale	9 on J1 and GROUND	22-28
Probe Resistance (Full or Right Vat) *	R x 1000 OHMS	2 and 6 on J3 or 13 and 14 on J2	**
Probe Resistance (Left - if present) *	R x 1000 OHMS	2 and 6 on J1 or 14 and 15 on J2	**
Probe Isolation	R x 1000 OHMS	6 on J1 or J3 and GROUND	***
High-Limit Continuity (Full or Right Vat)	R x 1 OHM	9 on J3 and Wire 13C on Gas Valve	0
High-Limit Continuity (Left - if present)	R x 1 OHM	9 on J1 and Wire 12C on Gas Valve	0
<p>* Disconnect 15-pin harness from controller before testing probe circuit.</p> <p>** See Probe Resistance Chart at the end of the chapter.</p> <p>*** 5 mega-Ohms or greater.</p>			

1.1.3 THERMOSTATS

Pro (H50/55) Series gas fryers have *temperature probes* located on the front centerline of each frypot (dual-vat frypots have two probes, one in each vat). In this type of thermostat, the probe resistance varies directly with the temperature. That is, as the temperature rises, so does resistance, at a rate of approximately 2 ohms for every 1° F. Circuitry in the controller monitors the probe resistance and controls burner firing when the resistance exceeds or falls below programmed temperatures (setpoints). The temperatures are programmed by means of a keypad on the face of the controller.

Pro (H50/55) Series fryers are also equipped with a *high-limit thermostat*. In the event that the fryer fails to properly control the oil temperature, the high-limit thermostat prevents the fryer from overheating to flash point. The high-limit thermostat acts as a normally closed power switch that opens when exposed to temperatures above 425°F to 450°F (218°C to 232°C). The different types of thermostats have different part numbers for CE and non-CE models and are not interchangeable.

1.2 Accessing Fryers for Servicing

 **DANGER**

Moving a fryer filled with cooking oil may cause spilling or splattering of the hot liquid. Follow the draining instructions in Chapter 4 of the Installation and Operation manual (P/N 819-5991) before relocating a fryer for servicing.

1. Shut off the gas supply to the unit. Unplug the power cords. Disconnect the unit from the gas supply.
2. Remove any attached restraining devices and relocate the fryer for service accessibility.

3. After servicing is complete, reconnect the unit to the gas supply, reattach restraining devices, and plug in the electrical cords.

1.3 Cleaning the Gas Valve Vent Tube

1. Set the fryer power switch and the gas valve to the OFF position.
2. Carefully unscrew the vent tube from the gas valve. **NOTE:** The vent tube may be straightened for ease of removal.
3. Pass a piece of binding wire (.052 inch diameter) through the tube to remove any obstruction.
4. Remove the wire and blow through the tube to ensure it is clear.
5. Reinstall the tube and bend it so that the opening is pointing down.

1.4 Checking the Burner Manifold Gas Pressure

1. **On non-CE fryers only**, ensure that the gas valve knob is in the OFF position.

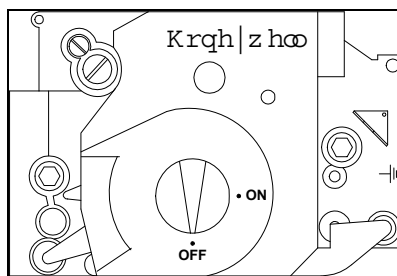

2. Remove the pressure tap plug from the gas valve assembly.

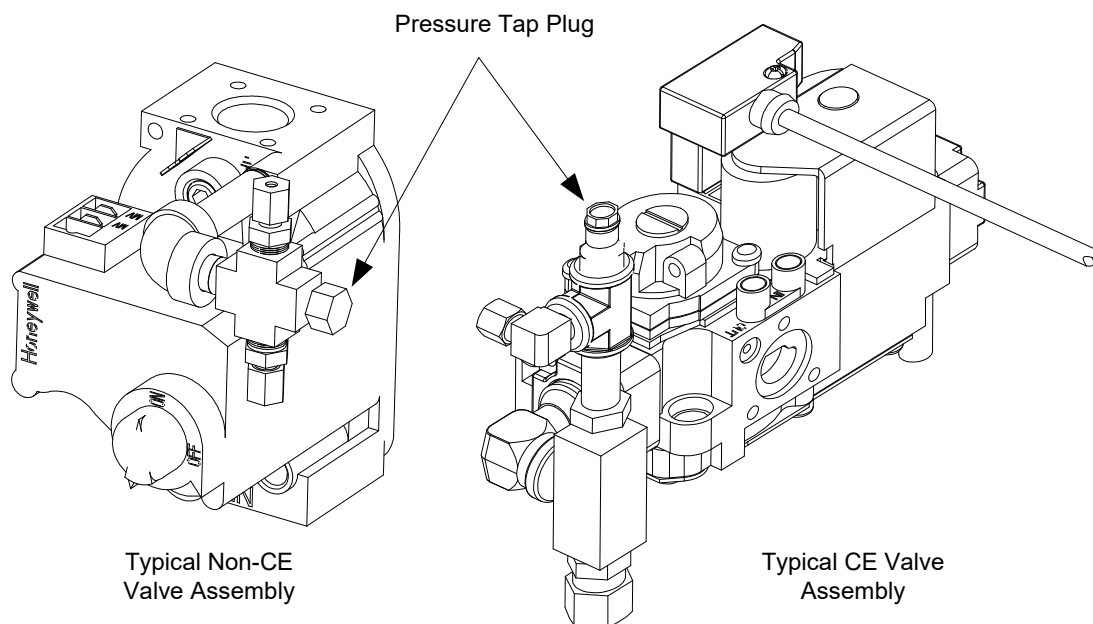

3. Attach a manometer or pressure gauge to the pressure tap hole.

4. **On non-CE fryers only**, place the gas valve in the ON position.
5. Place the fryer power switch in the ON position. When the burner has lit and burned steadily for at least one minute, compare the gas pressure reading to the pressure for the corresponding gas in the appropriate table below. The tables list the burner manifold gas pressures for each of the gas types that can be used with this equipment.

CE Standard Burner Manifold Gas Pressures		
Gas	Pressure (mbar)	
	Single Vat	Dual Vat
Natural Gas Lacq (G20) under 20 mbar	7	7
Natural Gas Gronique * (G25) under 25 mbar	10	10
Natural Gas Gronique (G25) under 20 mbar	10	10
Butane/Propane (G30) at 28/30 or 50 mbar	17	17
Propane (G31) under 37 or 50 mbar	20	20

* Belgian G25 = 7,0 mbar (single or dual)

Non-CE Standard Burner Manifold Gas Pressures	
Gas	Pressure
Natural	3" W.C. 0.73 kPa
Propane	8.25" W.C. 2.5 kPa

6. To adjust the burner gas pressure, remove the cap from the gas valve regulator and adjust it to the correct pressure.

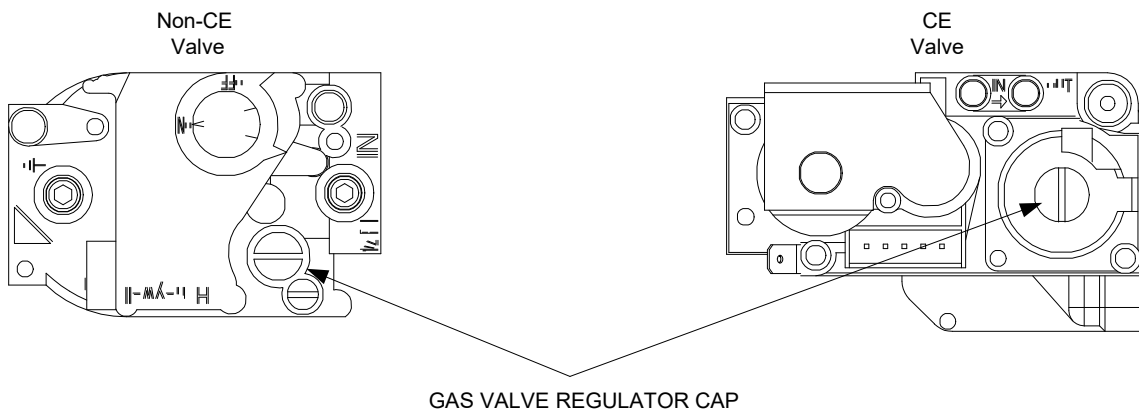

7. Place the fryer power switch (and the gas valve in non-CE fryers) in the OFF position. Remove the fitting from the pressure tap hole and reinstall the pressure tap plug.

1.5 Measuring Flame Current

When the burner flame is properly adjusted, it will produce a current between 2.5 μA and 3.5 μA . Flame current is measured by placing a *microamp* (not milliamp) meter in series with the sensing wire on the ignitor.

1. Place the fryer power switch in the OFF position.
2. Disconnect the sensing wire from one of the burner ignitors and connect it to the positive lead of the meter. Connect the negative lead of the meter to the terminal from which the sensing wire was removed.

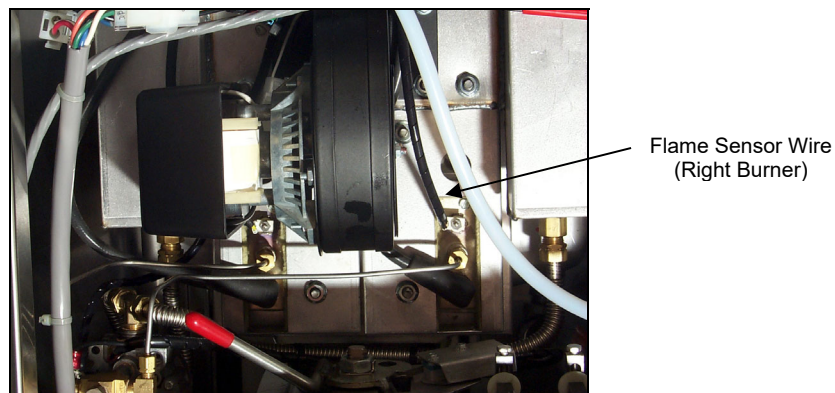

3. Place the fryer power switch in the ON position to light the burners. After the frypot temperature reaches 200°F (93°C), wait at least one minute before checking the reading. **NOTE:** The closer the unit is to normal operating temperature, the more accurate the reading will be.

1.6 Replacing Fryer Components

1.6.1 Replacing the Controller or the Controller Wiring Harness

1. Unplug all electrical power cords.
2. Lift up on the bezel to disengage the tabs on its lower edge from the control panel frame. Slide the bezel down to disengage the upper tabs. Remove the top two screws. Swing the controller out from the top and allow it to rest on its hinge tabs.
3. Disconnect the wiring harness from the back of the controller and, if replacing the harness, disconnect it from the interface board.
4. Disconnect the ground wire from the controller. Remove the controller by lifting it from the hinge slots in the control panel frame.
5. Reverse the procedure to install a new controller or wiring harness. **NOTE:** Ensure that the ferrite bead (black ring) in the harness is at the controller end.

1.6.2 Replacing the Temperature Probe or High-Limit Thermostat

1. Disconnect the fryer from the electrical supply.
2. Drain cooking oil below the level of the probe or thermostat.
3. Lift up on the bezel to disengage the tabs on its lower edge from the control panel frame. Slide the bezel down to disengage the upper tabs. Remove the top two screws. Swing the controller out from the top and allow it to rest on its hinge tabs.
4. Disconnect the controller wiring harness and ground wire from the back of the controller and remove the controller by lifting it from the hinge slots in the control panel frame.
5. If the fryer has a built-in filtration system, remove the cotter pin securing the oil return handle to the oil return operating rod and separate the rod from the handle.
6. Disconnect the ignition cables from the ignitors by grasping the boots and gently pulling toward you.
7. Disconnect the flame sensor wires from the flame sensors.
8. Disconnect the sound device lead from the interface board.
9. If working on the left frypot, cut the wire tie on the wiring bundle and disconnect the main wiring harness 15-pin connector.
10. Remove the component box mounting screws.
11. Rotate the top of the component box out of the frame and carefully pull it out enough to disconnect the wiring harness plug from the back of the box. If the unit is equipped with built-in filtration, disconnect the wires from the filter switch. This will leave one set of wires, enclosed in spiral wrap, connected to the component box.
12. Remove the box and place it on top of the fryer to expose the temperature probe and high-limit thermostat.
13. Cut the leads of the probe or thermostat, as appropriate, near the component and unscrew it from the frypot.
14. Unscrew and remove the temperature probe (or high-limit thermostat) from the frypot.
15. Apply Loctite® PST56765 pipe thread sealant or equivalent to the replacement part threads and screw the replacement part into the frypot, torquing to 180 inch-pounds.
16. Connect the wires from the new component as follows:
 - a. If replacing the temperature probe, use a pin pusher to disconnect (one at a time) the red and white leads from the connector and insert the corresponding leads from the new probe.

- b. If replacing the high-limit thermostat, use a pin pusher to disconnect the lead running to the connector and insert the corresponding lead from the new thermostat. Disconnect the other lead from the drain safety switch and connect the remaining lead from the new thermostat.

17. Reverse steps 1-12 to reassemble the fryer.

1.6.3 Replacing the Interface Board

1. Disconnect the fryer from the electrical power supply.
2. Lift up on the bezel to disengage the tabs on its lower edge from the control panel frame. Slide the bezel down to disengage the upper tabs. Remove the top two screws. Swing the controller out from the top and allow it to rest on its hinge tabs.
3. Disconnect the wiring harness from the back of the controller and from the interface board, and disconnect the ground wire from the controller.
4. Remove the controller by lifting it from the hinge slots in the control panel frame.
5. Disconnect the wires attached to the interface board, marking or making a note of the wires and terminals to facilitate reconnection.
6. Remove the nuts at each corner of the interface board and carefully pull it from the studs far enough to allow the connector on the back of the board to be disconnected, then remove the board from the box. When removing the board, be careful not to lose the spacers that fit over the studs behind the board.
7. Recover the relay(s) from the failed interface board and install on the replacement board.
8. Reverse the procedure to install the replacement board, being sure that the spacers behind the board are in place.

1.6.4 Replacing an Ignition Module

1. Disconnect the fryer from the electrical supply.
2. Lift up on the bezel to disengage the tabs on its lower edge from the control panel frame. Slide the bezel down to disengage the upper tabs. Remove the top two screws. Swing the controller out from the top and allow it to rest on its hinge tabs.
3. Disconnect the wires from the ignition module, marking or making a note of the wires and terminals to facilitate reconnection.
4. Remove the four ignition module screws and pull the module from the component box.
5. Move the spacers to the new module.
6. Reverse the procedure to install the replacement module.

1.6.5 Replacing an Ignitor Assembly



DANGER

Drain the frypot or remove the handle from the drain valve before proceeding further.

1. Disconnect the fryer from the electrical supply.
2. Disconnect the flame sensor wire by carefully pulling its push-on terminal from the terminal strip on the ignitor. Disconnect the gas enrichment tube at the ignitor-end compression fitting. Disconnect the ignition cable from the ignitor by grasping its boot and gently pulling toward you.

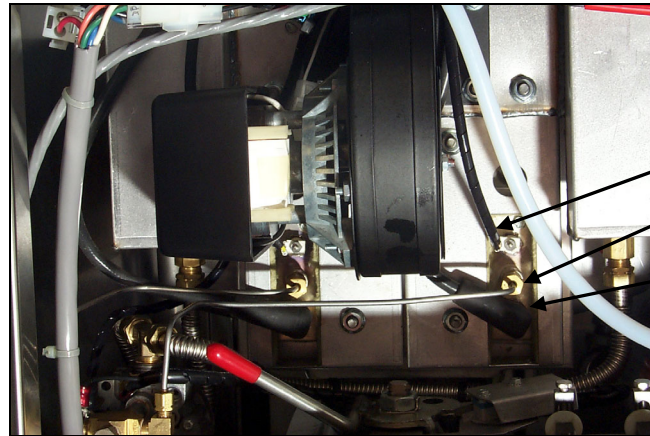

Flame Sensor Wire

Gas Enrichment Tube

Ignition Cable

3. Remove the sheet metal screws securing the ignitor to the mounting plate and pull the ignitor from the fryer.
4. Reverse the procedure to install the replacement ignitor.

1.6.6 Replacing or Cleaning a Combustion Air Blower

1. Disconnect the blower wiring harness, remove the blower assembly mounting nuts, and remove the blower assembly from the fryer. If cleaning the motor, continue with Step 2; otherwise, install the replacement blower, reconnect the wiring harness, and then go to Step 6.

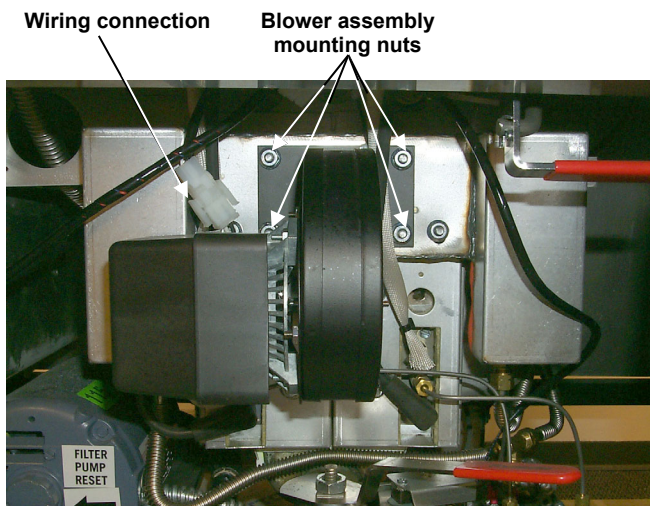

2. Remove the blower motor shield and separate the blower motor from the housing as shown in the illustration on the following page.

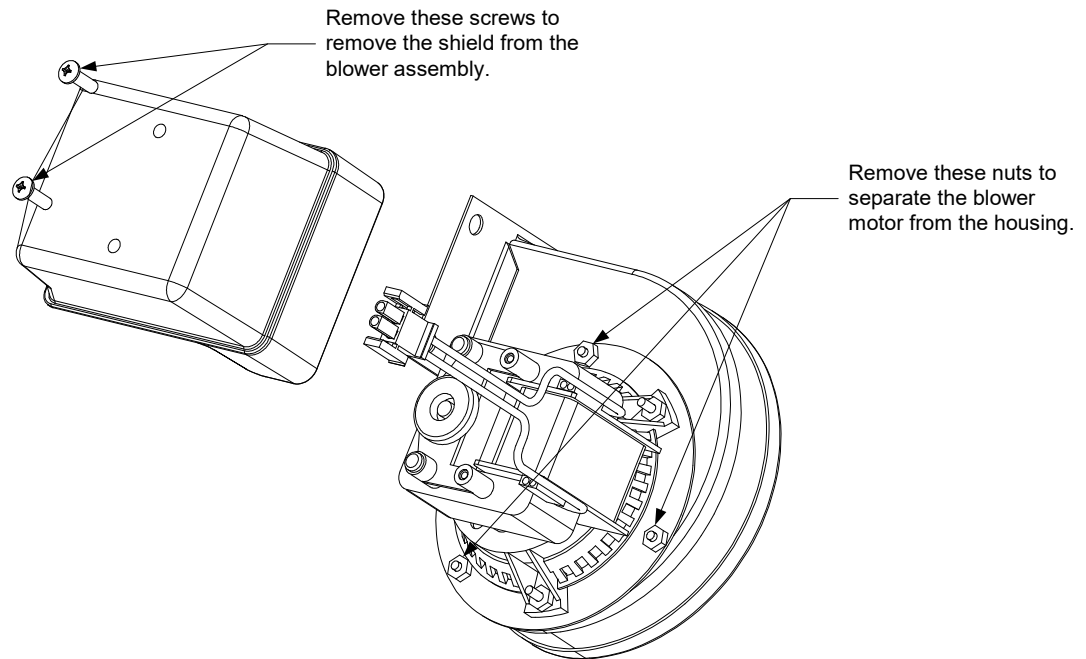

3. Wrap the motor with plastic wrap to prevent water from entering it. Spray degreaser or detergent on the blower wheel and the blower housing. Allow it to soak for five minutes. Rinse the wheel and housing with hot tap water, then dry with a clean cloth.

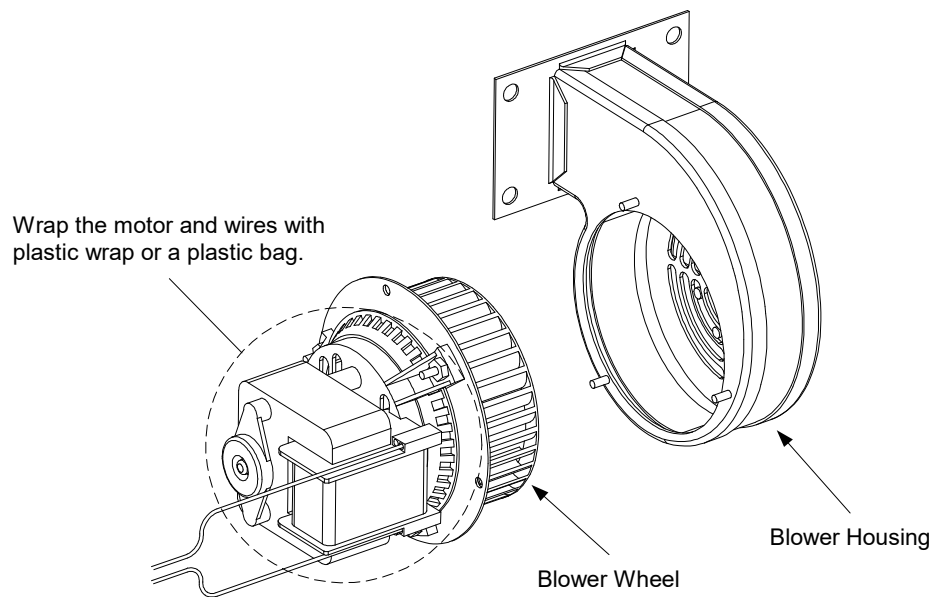

4. Remove the plastic wrap from the blower motor assembly. Reassemble the blower motor assembly and blower housing. Reinstall the blower shield.
5. Reinstall the blower assembly in the fryer and reconnect the wiring disconnected in Step 1.

6. Light the fryer in accordance with the procedure described in Chapter 3, Section 3.2 of the Pro H55-Series Gas Fryer Installation and Operation Manual (P/N 819-5991).
7. After the burners have been lit for at least 90 seconds, observe the flames through the burner sight glasses located on each side of the combustion air blower.

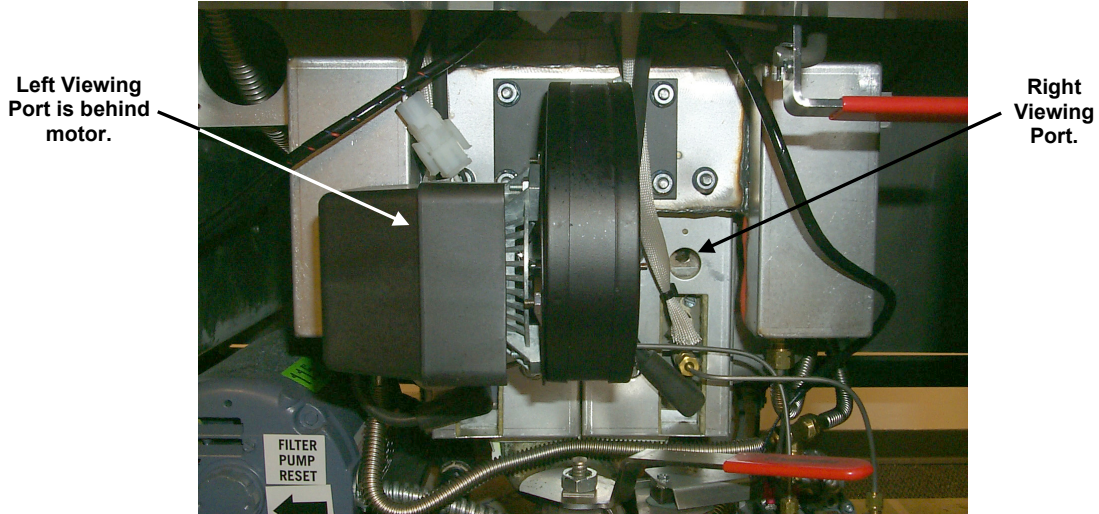

The air/gas mixture is properly adjusted when the burner manifold pressure is in accordance with the applicable table on page 1-6 and the burners display a bright red-orange glow. If a blue flame is observed or if there are dark spots on the burner face, the air/gas mixture requires adjustment.

Adjusting the Air/Gas Mixture

On the side of the blower housing opposite the motor is a shutter plate with a locking nut. Loosen the nut enough to allow the shutter to be moved, then adjust the position of the shutter to open or close the air intake opening until a bright red-orange glow is obtained. Carefully hold the shutter in position and tighten the locking nut.

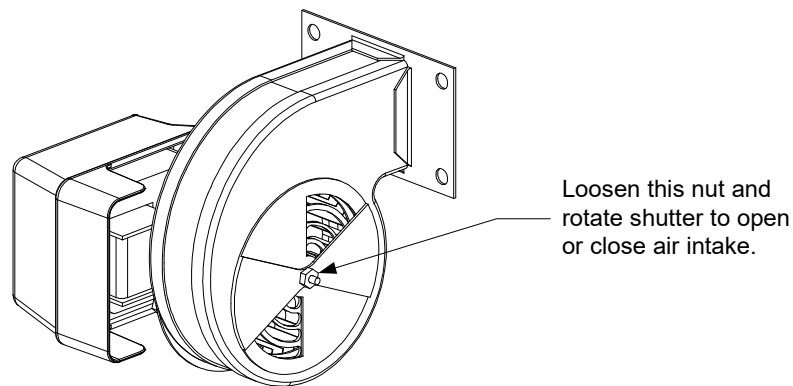

1.6.7 Replacing a Gas Valve



Drain the frypot or remove the handle from the drain valve before proceeding further.

1. Disconnect the fryer from the electrical and gas supplies.
2. Disconnect the drain safety and high-limit thermostat wires from the gas valve. Mark each wire to facilitate reconnection.
3. Remove the vent tube (on non-CE fryers) and the enrichment tube fitting from the valve. Disconnect the flexible gas line(s).

If replacing the left-most valve on any configuration, or the right valve on a two-fryer battery, follow the instructions below. If replacing valves in other positions, skip to “ALL OTHER VALVES.”

- A. Remove the filter pan from the unit. Remove the door adjacent to the valve being replaced.
- B. Remove the five screws on the front face of the pan rail assembly adjacent to the valve being replaced. Remove the nut and bolt securing the rear end of the rail to the cabinet.
- C. Remove the two nuts and bolts immediately behind the front face of the pan rail assembly. Pull the assembly from the unit to gain access to the pipe union on the gas line.
- D. Uncouple the pipe union and remove the gas valve and associated piping from the unit.
- E. Remove the fittings and associated piping from the failed valve and install them on the replacement valve using Loctite® PST56765 or equivalent pipe thread sealant.
- F. Reconnect the gas valve assembly to the fryer using Loctite® PST56765 or equivalent pipe thread sealant, and reattach the flexible gas line(s), enrichment tube(s), and the vent tube (on non-CE units). Reconnect the high-limit thermostat wires and drain safety wires to the valve.
- G. Reconnect the fryer to the gas supply and open the cut off valve. Apply a solution of soapy water around each connection to check for gas leaks. Eliminate any that are found.
- H. Position the pan rail assembly beneath the fryer and rest the rear end of the rail on the cabinet frame. Install the two nuts and bolts behind the front face of the rail, but do not tighten them. Install the nut and bolt at the rear end of the filter rail and tighten securely.
- I. Install the five screws in the front face of the rail, but do not tighten them. Install the filter pan in the unit to make sure that all components are properly aligned; then, securely tighten the remaining bolts and screws.
- J. Reconnect the fryer to the electrical power supply and check for proper operation. When proper operation has been verified, reinstall the door removed in Step A.

ALL OTHER VALVES

4. Carefully unscrew the valve from the manifold. **NOTE:** Some models may have the valve attached to the manifold by means of a pipe union. In such cases, remove the valve by uncoupling the union.
5. Remove all fittings from the old gas valve and install them on the replacement valve, using Loctite® PST56765 or equivalent pipe thread sealant.
6. Reconnect the gas valve assembly to the fryer using Loctite® PST56765 or equivalent pipe thread sealant, and reattach the flexible gas line(s), enrichment tube(s), and the vent tube (on non-CE units). Reconnect the high-limit thermostat wires and drain safety wires to the valve.
7. Reconnect the fryer to the gas supply and open the cut off valve. Apply a solution of soapy water around each connection to check for gas leaks. Eliminate any that are found.
8. Reconnect the fryer to the electrical power supply and check for proper operation.

1.6.8 Replacing a Burner Assembly



Drain the frypot or remove the handle from the drain valve before proceeding further.

1. Disconnect the unit from the electrical and gas supplies.
2. Remove the combustion air blower by following the instructions in Section 1.6.6.
3. Remove the four nuts from the air plenum assembly and pull the assembly straight out toward you until it clears the burner tubes.

NOTE: On a dual-vat fryer, it will be necessary to remove the drain valve handles before the plenum can be removed.

NOTE: If the flexible oil return lines are blocking the plenum, carefully bend them upward enough to clear the plenum.

4. Disconnect the ignition cable from the ignitor by grasping its boot and pulling gently toward you. Disconnect the flame sensor wire from the ignitor by gently pulling its push-on terminal from the terminal strip on the ignitor.
5. Disconnect the flexible gas lines from the burner orifice and the enrichment tube from the ignitor assembly.
6. Remove the four ¼-inch nuts securing the outer front covers to the frypot assembly.
7. Remove the sheet metal screws at the top of the outer front covers and pull the covers straight out toward you until clear of the mounting studs.

8. Remove the washers and tubular spacers from the mounting studs, then pull the inner covers straight out toward you until clear of the mounting studs.
9. Grasp the burner firmly and pull it toward you until it clears the burner channels, taking care not to damage the ceramic tiles in the process.
10. Clean all debris from the burner channels and combustion area.
11. Inspect the upper and lower burner rails for cracked or burned out welds.
 - a. If the welds in the lower rail are cracked or burned out, the frypot must be replaced. Refer to Section 1.6.10 for instructions.
 - b. If the welds in the upper rail are cracked or burned out, the upper rail must be replaced. Refer to Section 1.6.11 for instructions.
12. Place a new insulating strip along the top, rear, and bottom edge of the burner and carefully slide it straight into the rails. **NOTE:** Use P/N 826-0931 for full-vat frypots and P/N 826-0932 for dual-vat frypots.
13. Reverse steps 1 through 9 to reassemble the components.
14. Fill the frypot with oil. Turn the fryer on, turn off or bypass the melt cycle, and operate the unit for at least 10 minutes.
15. Visually examine the burner flame. The color and intensity on both sides should be the same.
16. Use an inspection mirror to check for leaks in areas that cannot be directly observed.
17. If a leak is detected, tighten all the lower insulation retainer nuts, allow the frypot to run for five additional minutes, and repeat steps 15 and 16.
18. If the leak persists, use a rubber hammer and a small block of wood to tap the corners of the lower combustion chamber insulation retainers. Repeat steps 15 through 17. **Repeat this step until no leakage is detected.**

1.6.9 Replacing the Filter Motor, Filter Pump, or Filter Pump Solenoid Valve

1. Disconnect the unit from the electrical power supply.
2. Remove the filter pan from the unit and drain the frypots into a Shortening Disposal Unit (SDU) or other appropriate metal container.



DO NOT attempt to drain more than one full frypot or two split frypots into the SDU at one time.

3. Position a container beneath the oil return fitting at the front of the cabinet. Disconnect the flexible oil line from the fitting, allowing any residual oil to drain into the container.

4. At the rear of the fryer, unplug the left connector (as viewed from the rear of the fryer) from the transformer box. Using a pin pusher, push the pump solenoid valve wires from Pins 7 and 9.
5. Remove the four nuts and bolts attaching the motor mount to the rear motor mount support.
6. At the front of the fryer, remove the cover plate from the front of the motor and disconnect the motor wires.
7. Place a 1-foot (30.5-cm) length of wood (or similar support) beneath the motor mount near the front of the unit and remove the two remaining nuts and bolts attaching the motor mount to the front cabinet cross-brace.
8. Carefully remove the support and lower the motor mount to the floor, allowing the rear of the mount to slide forward and off the rear motor mount support.
9. Disconnect the Power Shower flexline (if applicable) or the oil return flexline from the pump. The motor and pump assembly can now be pulled from beneath the fryer and the failed component can be removed and replaced.
10. Position the new/repaired motor and pump assembly beneath the fryer and reconnect the Power Shower flexline (if applicable) or the oil return flexline to the pump. Lift the rear of the motor mount up and onto the rear motor mount support.
11. Lift the front of the motor mount up and support it with a 1-foot (30.5-cm) piece of wood or a similar support. Install but do not tighten the two nuts and bolts that attach the motor mount to the front cabinet cross-brace.
12. Install and tighten the four nuts and bolts that secure the motor mount to the rear motor mount support. Reconnect the solenoid valve wires to Pins 7 and 9 of the 9-pin connector (polarity does not matter) and reconnect the plug.
13. At the front of the fryer, tighten the two nuts and bolts at the front of the motor mount. Reconnect the motor power wires and reinstall the wiring cover plate.
14. Reconnect the oil return flexline and reinstall the filter pan.
15. Reconnect the unit to the electrical power supply, fill the frypots with oil, and check for proper operation.

1.6.10 Replacing the Frypot

1. Disconnect the fryer from the electrical and gas supplies.
2. Remove the filter pan from the unit and drain the frypots into a Shortening Disposal Unit (SDU) or other appropriate metal container.



DANGER

DO NOT attempt to drain more than one full frypot or two split frypots into the SDU at one time.

3. Dismount the topcap by removing the screws on the bottom of each front corner and lifting the topcap straight up.
4. Remove the bezels by lifting them up to disengage the tabs along the lower edges from the slots in the control panel frame.
5. Grasp the upper edge of each controller and swing the controller downward. Unplug the controller wiring harness and grounding wire from the back of each controller.
6. Remove the controllers by lifting them from the hinge slots in the control panel frame.
7. Remove the cotter pin that secures the oil return rod to the oil return handle and separate the rod and handle. **NOTE:** On split-vat units, there are two oil return handles.
8. Disconnect the sound device wire from the interface board and disconnect the oil return switch wires from the switch terminals.
9. Disconnect the flame sensor wires by carefully pulling the push-on terminals from the terminal strips on the ignitors. Disconnect the gas enrichment tube at the ignitor-end compression fitting. Disconnect the ignition cables from the ignitors by grasping the boots and gently pulling toward you.
10. Remove the two mounting screws on each side of the component box and rotate the top of the box out of the frame. Carefully pull it out enough to disconnect the wiring harness connector from the back of the box. Cut any ties that prevent the box from being pulled out of the control panel frame.
11. Carefully pull the box clear of the frame and rest it on the top of the fryer.
12. Using a pin pusher, remove the temperature probe and high-limit thermostat wires from the plugs or terminals, marking each wire to facilitate re-assembly.
13. Remove the cover from the safety drain switch. Disconnect the wires from the switch.
14. Remove the section(s) of drain from the drain valve(s) of the frypot to be removed.
15. Disconnect the gas lines from the burner orifices and ignitor assemblies.
16. Remove the frypot hold down bracket.
17. Remove the screws in the back panel and inside the flue cap at each end that secure the flue cap to the fryer and lift it clear of the fryer.
18. Disconnect the oil return line(s) from the frypot to be removed.
19. Carefully lift the frypot from the fryer cabinet.

20. Remove the drain valve(s), temperature probe(s), high-limit thermostat(s), and ignitor assemblies. Inspect each of these components carefully and install them in the replacement frypot if they are in serviceable condition. Use Loctite® PST56765 sealant or equivalent on component threads.

NOTE: Some servicers, based upon their experience, recommend replacing probes and thermostats whenever a frypot is replaced; however, this remains the customer's decision.

21. Reverse steps 1-19 to reassemble fryer.

NOTE: Care should be taken not to over-torque nuts on frypots made of 439 stainless steel, as this could tear the material. One turn past hand-tight is sufficient torque.

22. Perform steps 14 through 18 of Section 1.6.8 to ensure that there are no leaks in the burner insulation.

 **CAUTION**

Before installing temperature probe, high-limit thermostat, and drain valve on replacement frypot, clean the threads and apply Loctite® PST56765 thread sealant or equivalent.

1.6.11 Replacing Frypot Insulation and/or Upper Burner Rails

NOTE: Replacing the burner rails requires completely tearing down the frypot and installing new frypot insulation. See the referenced illustrations for component identification.

To remove the old insulation and/or upper burner rails (use illustration on page 1-20):

1. Remove the frypot according to the instructions in Section 1.6.10.
2. Remove the burner assemblies (1).
3. Remove insulation retainers and blanket insulation (2).
4. Remove the upper oil zone insulation bracket and upper oil zone insulation (3).
5. Remove the plenum (4).
6. Remove the front lower combustion chamber insulation retainer and insulation (5), and the front lower combustion chamber inner insulation retainer and insulation (6). **NOTE:** Full-vat units have two-piece insulation retainer and insulation components. Dual-vat units have one-piece components.
7. Remove the upper combustion chamber insulation retainer and insulation (7).
8. Remove the inner upper combustion chamber insulation retainer and insulation (8).
9. Remove the rear lower combustion chamber retainers, back, and insulation (9). **NOTE:** Full-vat units have two-piece backs and four retainers. Dual-vat units have one-piece backs and two retainers.
10. Remove the flue assembly (10).
11. Remove the upper burner rails (11).
12. Remove any residual insulation, sealant, and/or oil from the exterior of the frypot.

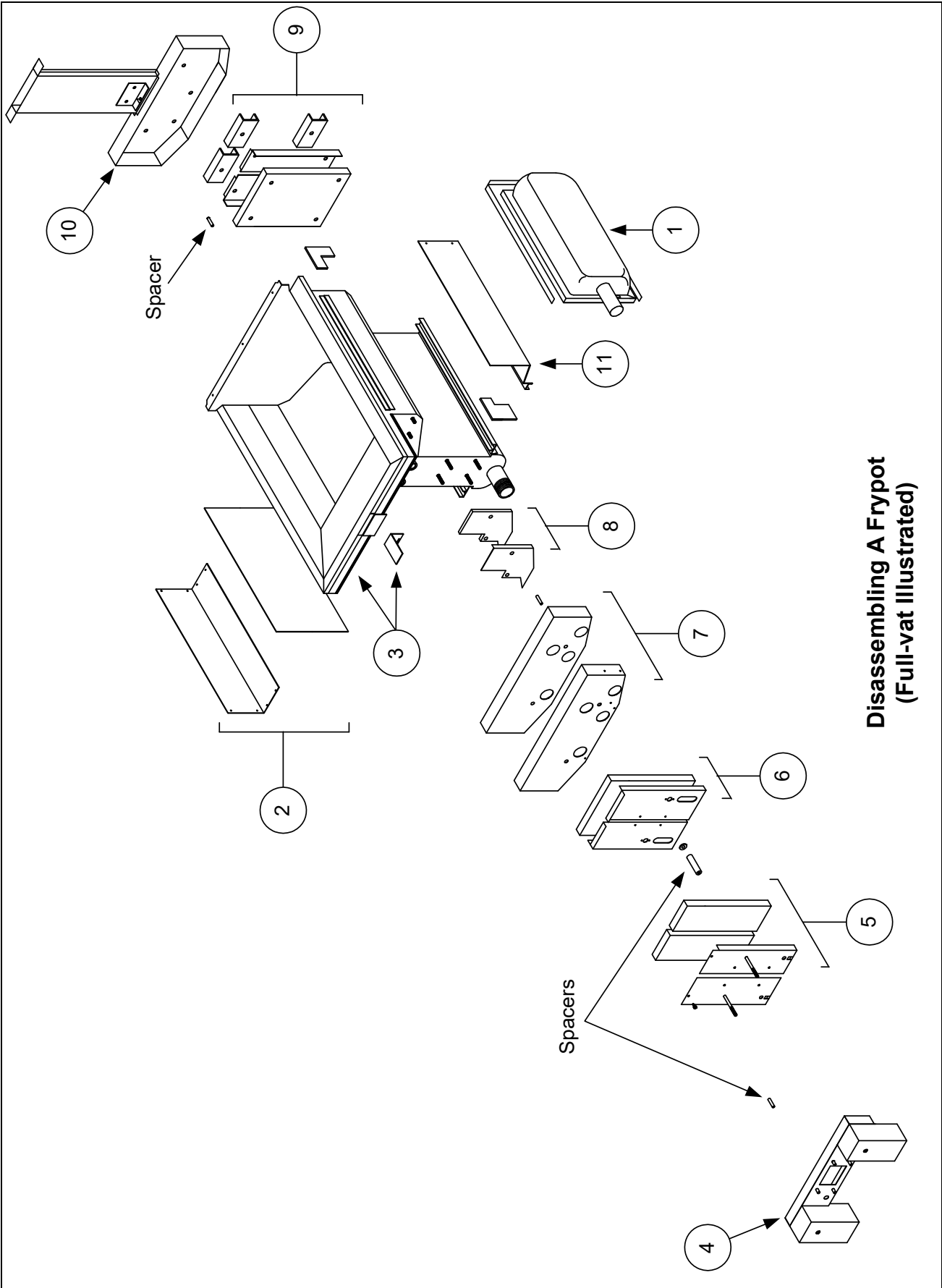

**Disassembling A Frypot
(Full-vat Illustrated)**

To re-assemble with new insulation and/or upper burner rails (use illustration on page 1-23):

13. Place the “L” shaped pieces of combustion chamber insulation (1) in the front and rear corners of both upper rail-retaining slots.
14. Use a small amount of furnace or muffler repair cement to seal the gaps at each end of both lower rails.
15. Install the upper burner rails (2) with the heat deflectors slanting toward the rear of the frypot. The rails will cover the “L” shaped pieces of combustion chamber insulation previously installed.
16. Place the upper inner combustion chamber insulation and insulation retainers (3) on the top two studs on each side of the front of the frypot and secure with ¼”-20 washer-nuts. *It is normal for the retainers to slice off the overhanging insulation.*
17. Place the lower rear combustion chamber insulation (4) on the lower four studs at the rear of the frypot.
18. Place one 1.625-inch tubular spacer (5) on each of the flue assembly (upper) studs at the rear of the frypot. **NOTE:** There are three different sizes of spacers. Verify the size to ensure the correct spacers are installed.
19. Press the flue assembly (6) over the burner rails. It may be necessary to use a rubber mallet or screwdriver to align the components. Use four ¼”-20 washer nuts to secure the flue assembly. **Do not tighten the retainer nuts at this point. They should be finger-tight only. NOTE:** The flue edge will cover one to two inches of the lower insulation.
20. Install the lower rear combustion chamber back(s) and retainer(s) (7) with the flanged edge(s) against the flue. Secure with ¼”-20 washer nuts. **NOTE:** Full-vat units have two-piece backs and four retainers. Dual-vat units come with one-piece backs and only two retainers.
21. Insert the burners (9) into the rails to ensure the rail spacing and alignment are correct. The burner should slide freely into and out of the rails. The upper rail can be bent slightly to increase or decrease tension on the burner and the edges of the slot can be closed or opened slightly to best fit the burner frame.
22. Carefully wrap a strip of burner insulation (8) tightly around the rear and sides of the burner frame (9), with the glass-tape side of the strip on the outside. **Do not use duct tape or adhesive to secure the strip to the burner frame.**
23. Align the burner to the burner rails while maintaining tension on the insulation strip. Insert the burner at a slight angle and begin pushing the burner slowly into the rails until it contacts the rear combustion chamber. The fit should be snug, but not excessively tight.
24. Verify that the burners are flush with the front edge of the burner rails. Remove the excess burner insulation by cutting with a knife or diagonal pliers. **Do not try to tear the insulation!**

25. Insert the upper front insulation (10) into its retainer (11), making sure that the holes in each piece are aligned with one another. Install the assembly with the insulation side toward the frypot and secure with ¼"-20 washer-nuts. **Do not over tighten.**
26. Place a washer on each of the four lower studs on the front of the frypot. Install the lower inner front insulation (12) with the rectangular openings toward the drain valve nipple. Install the lower inner front insulation retainer(s) (13). **NOTE:** Full-vat units have a two-piece insulation retainer. Dual-vat units have a one-piece retainer.
27. If necessary, replace the sight-glasses and insulation (14).
28. Place one washer and one 1.888-inch spacer (15) on each stud. **NOTE:** There are three different sizes of spacers. Verify the size to ensure the correct spacers are installed.
29. Insert the front lower insulation (16) into the front lower insulation retainer(s) (17) and install assembly on frypot. Secure with ¼"-20 washer-nuts. If frypot uses two retainers, connect them together with two ¼" self-tapping screws. **NOTE:** Full-vat units have a two-piece insulation retainer and two pieces of insulation. Dual-vat units have one-piece components.
30. Return to the rear of the frypot and fully tighten all washer-nuts.
31. Remove and replace the plenum gaskets (18).
32. Place a 0.938-inch spacer (19) on the plenum-mounting studs, and mount the plenum (20). Ensure the gaskets are clear of the burner tubes by pulling the plenum back slightly. Place a washer on each stud and secure plenum with ¼"-20 lock-nuts.
33. Install the upper oil-zone insulation (21) by pressing it under the upper combustion chamber metalwork. Secure the insulation with the bracket (22) and ¼" self-tapping screws.
34. Install the upper burner rail blanket insulation (23). Position any excess insulation toward the top of the frypot. Avoid overhang past the bottom of the upper burner rail. Overhang in this area will make future burner replacement more difficult.
35. Cover the insulation with the insulation retainer (24), and secure with ¼" self-tapping screws.
36. Reinstall probes, drain valves, high-limit thermostats, and other pipefittings using Loctite® PST56765 sealant or equivalent on the threads.

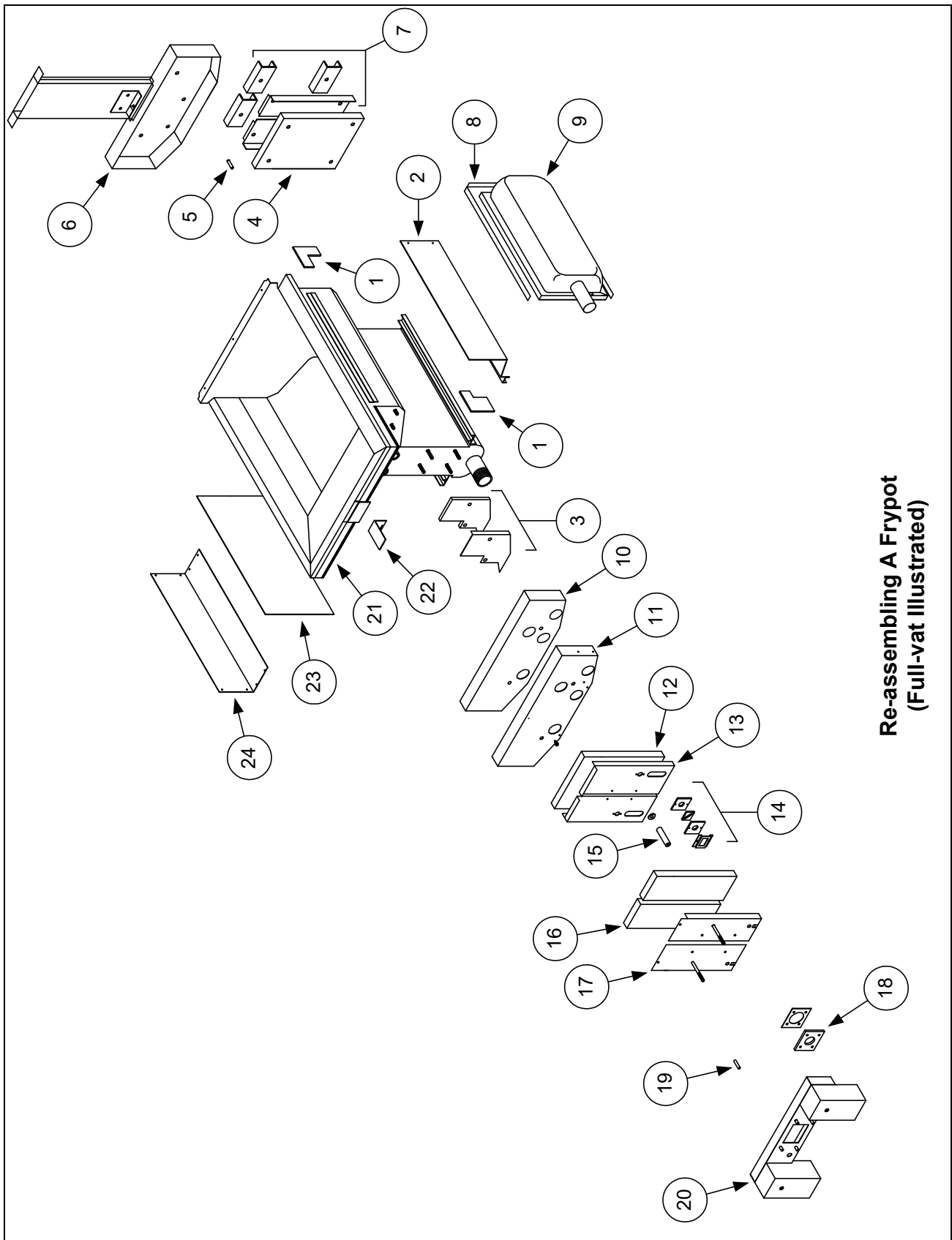

**Re-assembling A Frypot
(Full-vat Illustrated)**

1.7 Troubleshooting and Problem Isolation

Because it is not feasible to attempt to include in this manual every conceivable problem or trouble condition that might be encountered, this section is intended to provide technicians with a general knowledge of the broad problem categories associated with this equipment, and the probable causes of each. With this knowledge, the technician should be able to isolate and correct any problem encountered.

Problems you are likely to encounter can be grouped into seven categories:

1. Ignition failure
2. Improper burner function
3. Improper temperature control
4. Computer malfunctions
5. Filtration malfunctions
6. Leakage
7. Basket lift malfunctions.

The probable causes of each category are discussed in the following sections. A series of Troubleshooting Guides is also included at the end of the chapter to assist in solving some of the more common problems, including the interpretation of digital controller lights.

1.7.1 Ignition Failure

Ignition failure occurs when the ignition module fails to sense a flame within the 4-second time delay period and locks out. When this happens, the module sends 24 VAC through the interface board alarm circuit to the controller/computer.

Analog controllers indicate ignition failure by illuminating the heat light and trouble light simultaneously. Digital, Computer Magic III.5, and Basket Lift Timer controls display “K H O S.”

The three primary reasons for ignition failure, listed in order of probability, are problems related to:

1. Gas and/or electrical power supplies
2. Electronic circuits
3. Gas valve.

PROBLEMS RELATED TO THE GAS AND/OR ELECTRICAL POWER SUPPLIES

The main indicators of this are that an entire battery of fryers fails to light and/or there are no indicator lights illuminated on the fryer experiencing ignition failure. Verify that the quick disconnect fitting is properly connected, the fryer is plugged in, the main gas supply valve is open, and the circuit breaker for the fryer electrical supply is not tripped.

PROBLEMS RELATED TO THE ELECTRONIC CIRCUITS

If gas and electrical power are being supplied to the fryer, the next most likely cause of ignition failure is a problem in the 24 VAC circuit. Verify that the drain valve is fully closed. The valve is attached to a microswitch that must be closed for power to reach the gas valve (often, although the

valve handle appears to be in the closed position, the microswitch is still open). If the valve is fully closed, refer to the troubleshooting guide, **TROUBLESHOOTING THE 24 VAC CIRCUIT**.

Some typical causes of ignition failure in this category include a defective sensing wire in the ignitor assembly, a defective module, a defective ignition wire, and a defective ignitor.

Occasionally you may encounter an ignition failure situation in which all components appear to be serviceable and the microamp reading is within specification, but the unit nevertheless goes into ignition failure during operation. The probable cause in this case is an intermittent failure of an ignition module. When the unit is opened up for troubleshooting, the module cools down enough to operate correctly; however, when the unit is again closed up and placed back into service the module heats up and fails.

PROBLEMS RELATED TO THE GAS VALVE

If the problem is not in the 24 VAC circuit, it is most likely in the gas valve. Before replacing the gas valve, refer to **TROUBLESHOOTING THE GAS VALVE**.

1.7.2 Improper Burner Function

With problems in this category, the burner ignites but exhibits abnormal characteristics such as “popping,” dark spots on the burner ceramics, fluctuating flame intensity, and flames shooting out of the flue.

“*Popping*” indicates delayed ignition. In this condition, the main gas valve is opening but the burner is not immediately lighting. When ignition does take place, the excess gas “explodes” into flame, rather than smoothly igniting.

The primary causes of popping are:

- Incorrect or fluctuating gas pressure
- Defective or incorrectly adjusted combustion air blower
- Inadequate make-up air
- Heat-damaged controller or ignition module
- Cracked ignitor or broken ignition wire
- Defective ignition module
- Cracked burner tile (typically causes a very loud pop).

If popping occurs only during peak operating hours, the problem may be incorrect or fluctuating gas pressure. Verify that the incoming gas pressure (pressure to the gas valve) is in accordance with the appropriate CE or non-CE Standard found in Section 2.3 of the Pro H55-Series Gas Fryer Installation and Operation Manual (part number 819-5991), and that the pressure remains constant throughout all hours of usage. Refer to Section 1.4, **Checking the Burner Manifold Gas Pressure** in this manual for the procedure for checking the pressure of gas supplied to the burner.

If popping is consistent during all hours of operation, the most likely cause is an insufficient air supply. Check for “negative pressure” conditions in the kitchen area. If air is flowing into the kitchen area, this indicates that more air is being exhausted than is being replenished and the burners may be starved for air.

If the fryer's gas and air supplies are okay, the problem is most likely with one of the electrical components. Examine the ignition module and controller for signs of melting, distortion, and/or discoloration due to excessive heat build-up in the fryer (this condition usually indicates improper flue performance). A melted or distorted ignition module is automatically suspect and should be replaced; however, unless the condition causing excessive heat is corrected, the problem is likely to recur.

Verify that the ignition wire is tightly connected at both ends and free of obvious signs of damage. Again, if damage is due to excessive heat in the fryer, that problem must also be corrected. Check for proper operation by disconnecting the wire from the ignitor (spark plug), inserting the tip of a screw driver into the terminal, and holding the shaft near the frame of the fryer as the power switch is placed in the ON position. A strong, blue spark should be generated for at least 4 seconds.

 **DANGER**

**Make sure you are holding the insulated handle of the screwdriver and not the blade.
The sparking charge is approximately 25,000 volts.**

Examine the ignitor (spark plug) for any signs of cracking. A cracked ignitor must be replaced.

If all other causes have been ruled out, examine the burner tiles for any signs of cracking. If cracking is found, the burner must be replaced.

Fluctuating flame intensity is normally caused by either improper or fluctuating incoming gas pressure, but may also be the result of variations in the kitchen atmosphere. Verify incoming gas pressure in the same way as for “popping,” discussed in the preceding paragraphs. Variations in the kitchen atmosphere are usually caused by air conditioning and/or ventilation units starting and stopping during the day. As they start and stop, the pressure in the kitchen may change from positive or neutral to negative, or vice versa. They may also cause changes in airflow patterns that may affect flame intensity.

Dark spots on the burner tiles are the result of an improper air/gas mixture. Adjust the combustion air blower to reduce the amount of air in the mixture to correct this problem

Flames shooting out of the flue are usually an indication of negative pressure in the kitchen. Air is being sucked out of the burner enclosure and the flames are literally following the air. If negative pressure is not the cause, check for high burner manifold gas pressure in accordance with the procedures in Section 1.4.

An **excessively noisy burner**, especially with **flames visible above the flue opening**, may indicate that the gas pressure is too high or that the gas valve vent tube is blocked. If the incoming gas pressure is correct and the vent tube is unobstructed, the gas valve regulator is probably defective.

Occasionally a burner may apparently be operating correctly, but nevertheless the fryer has a **slow recovery rate** (the length of time required for the fryer to increase the oil temperature from 250°F to 300°F (121°C to 149°C)). The primary causes of this include an over-filled frypot, a dirty or out-of-adjustment combustion air blower, low burner manifold pressure, and/or damaged burner tiles. Adding oil to the frypot during the recovery process will also cause a slow recovery rate. If these causes are ruled out, the probable cause is a misadjusted gas valve regulator. Refer to Section 1.4, **Checking the Burner Manifold Gas Pressure**, for the gas valve adjustment procedure.

1.7.3 Improper Temperature Control

Temperature control, including the melt cycle, is a function of several interrelated components, each of which must operate correctly. The principle component is the temperature probe. Other components include the interface board, the controller, and the ignition module.

Improper temperature control problems can be categorized into melt cycle problems and failure to control at setpoint problems.

MELT CYCLE PROBLEMS

In fryers equipped with analog controls, the melt cycle must be initiated by pressing the melt cycle switch. With all other controllers, initiation of the melt cycle is automatic. Problems may originate from the controller, the temperature probe, or a malfunctioning heat relay on the interface board.

FAILURE TO CONTROL AT SETPOINT

Problems in this category may be caused by the temperature probe, the interface board, or the controller.

1.7.4 Computer Malfunctions

SENSITIVITY OR “STRETCH AND SHRINK TIME.”

Sensitivity – “stretch time” – is a programmable feature, patented by Frymaster, which increases or decreases the cook time countdown based on variations in the oil temperature from the set point.

The sensitivity for each product button has ten settings (0 through 9). A sensitivity setting of zero will disable the feature (no change in cooking time), while a nine will provide the highest sensitivity or most change. The correct sensitivity for any product is based on the product, its density, the set point temperature, and the customer’s own requirements. A chart is provided in the Frymaster Fryer Controllers User’s Manual included with your fryer to assist you in setting sensitivity.

RECOVERY TIME

Recovery time – is a method of measuring a fryer’s performance. It is the time required for the fryer to increase the oil temperature from 250°F to 300°F (121°C to 149°C). This range is used as a standard since ambient kitchen temperatures can effect the test if lower ranges are used.

The Computer Magic III.5 performs the recovery test each time the fryer warms up. An operator can view the results of the test any time the fryer is above the 300°F (149°C) point by pressing the button and entering the code 1652. The test results will be displayed in the computer’s LED panel in minutes and seconds. The maximum acceptable recovery time for Pro H55-Series gas fryers is two minutes and twenty-five seconds.

COMMON COMPUTER COMPLAINTS

Most problems concerning computers have to do with programming them. There are four common complaints:

1. Fryer constantly displays “KL”

Cause: Setpoint is incorrect or missing.

Corrective Action: Press 1650, enter the correct setpoint using keypad, then press to lock in the setpoint.

2. Temperature is displayed in Celsius.

Cause: Computer is programmed to display in Celsius.

Corrective Action: Turn off computer first. Then press 1658.

3. Temperature is constantly displayed.

Cause: Computer is programmed for constant temperature display.

Corrective Action: Press 165L.

4. Computer times down too slowly or too quickly.

Cause: Computer is compensating for oil temperature via the sensitivity setting.

Corrective Action: Reprogram sensitivity setting for each product. Refer to the appropriate section of the separate Frymaster Fryer Controllers User’s Manual furnished with your fryer for the operating instructions for your specific controller and suggested sensitivity settings.

1.7.5 Filtration Malfunctions

The majority of filtration problems arise from operator error. One of the most common errors is placing the filter paper on the bottom of the filter pan rather than over the filter screen.

Whenever the complaint is “the pump is running, but no oil is being filtered,” check the installation of the filter paper, including that the correct size is being used. While you are checking the filter paper, verify that the O-rings on the filter pan suction tube are present and in good condition. Missing or worn O-rings will allow the pump to suck air and decrease its efficiency.

If the pump motor overheats, its thermal overload will trip, and the motor will not start until it is reset. If the pump motor does not start, press the red reset switch located on the front of the motor. If the pump then starts, something caused the motor to overheat. It may be just that several frypots in a large battery of fryers were being filtered one after the other and the pump got hot. Letting the pump cool down for at least a half-hour is all that is required in this case. More often, the pump overheated for one of the following reasons:

- Shortening that remained in the pan after previous filtering solidified in the suction tube recess in the bottom of the pan or the suction tube. Adding hot oil to the pan and waiting a few minutes will usually correct this problem. A flexible wire can be used to clean out the suction tube and the recess in the bottom of the pan. **NEVER** use compressed air to blow solidified shortening out of the suction tube!
- The operator attempted to filter oil that was not heated. Cold oil is thicker and causes the pump motor to work harder and overheat.

If the motor hums but the pump does not rotate, there is a blockage in the pump. Incorrectly sized or installed paper will allow food particles and sediment to pass through the filter pan and into the pump. When sediment enters the pump, the gears can bind up and cause the motor to overload, tripping the thermal overload. Solidified shortening in the pump will also cause it to seize, with similar results.

A pump seized by debris or hard shortening can usually be freed by manually moving the gears with a screwdriver or other instrument as illustrated below. **Make sure power to the pump motor is off before trying this.**

1. Disconnect power to the filter system.
2. Remove the input plumbing from the pump.
3. Use a screwdriver to manually turn the gears.
 - Turning the pump gears backwards will release a hard particle and allow its removal.
 - Turning the pump gears forward will push softer objects and solid shortening through the pump and allow free movement of the gears.

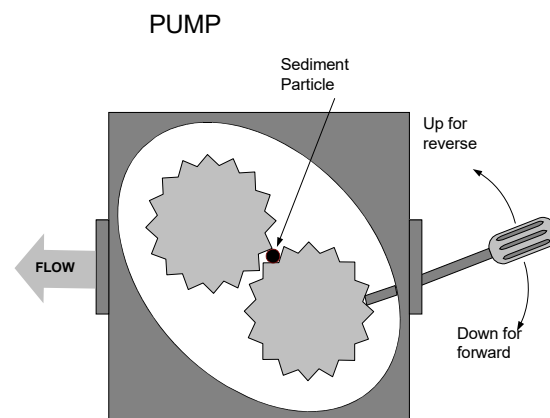

Paper sized or installed incorrectly will also allow food particles and sediment to pass through and clog the suction tube recess on the bottom of the filter pan or the suction tube. Particles large enough to block the suction tube recess or the suction tube may indicate that the crumb tray is not being used.

Possible problems if a Power Shower is installed include clogged openings, shortening solidified in the tubes, missing clean-out plugs, and missing or worn O-rings. Cleaning the unit and replacing missing plugs and missing or worn O-rings will correct these problems.

The electronics of the FootPrint Pro system, illustrated in the schematic at right, are simple and straightforward.

Microswitches, which are attached to handles for each vat and wired in parallel, provide the 24 VAC required to activate the pump relay coil when the handles are moved to the ON position. The activated pump relay coil pulls in the pump motor switch, supplying power to the pump motor.

Verifying Solenoid Operation

Proper operation of the 24 VAC manifold and pump solenoids can be verified by removing the pump motor lead from terminal 4 of the pump motor relay in the filter wiring box and then activating the oil return lever. Proper solenoid operation will be evidenced by an audible “click” or vibration of both the pump solenoid and the manifold solenoid.

1.7.6 Leakage

Leakage of the frypot will usually be due to improperly sealed high-limit thermostats, temperature probes, and drain fittings. When installed or replaced, each of these components must be sealed with Loctite® PST56765 sealant or equivalent to prevent leakage. In very rare cases, a leak may develop along one of the welded edges of the frypot. When this occurs, the frypot must be replaced.

If the sides and/or ends of the frypot are coated with oil/shortening, the most likely cause is spillage over the top of the frypot rather than leakage.

The clamps on the rubber boots that hold the drain tube sections together may loosen over time as the tubes expand and contract with heating and cooling during use. In addition, the boot may be damaged. If the section of drain tube connected to the drain valve is removed for any reason, ensure that its rubber and clamps are in good condition and properly fitted around the drain tube when it is reinstalled. Also, check to insure that the drain tube runs downward from the drain along its whole length and has no low points where oil or shortening may accumulate.

1.7.7 Basket Lift Malfunctions

Pro H50/55 Series fryers may be optionally equipped with automatic basket lifts to ensure uniform cooking times. Basket lifts will always come in pairs, although each operates independently of the other. A modular basket lift consists of a toothed rod to which the basket lift arm is attached, a reversible-drive gear motor, and a pair of roller-activated microswitches. A gear on the motor shaft engages teeth in the rod. Depending upon the direction of motor rotation, the gear drives the rod up or down.

Timing circuitry in the controller initiates and stops operation of the basket lift depending upon the variables programmed by the operator. When a product button is pressed, the timing circuitry activates a coil to supply power to the motor, which lowers the basket into the frypot.

When the rod contacts and closes the lower microswitch, power to the motor is cut and the direction of current flow is reversed; this reverses the direction of motor rotation. When the programmed cooking time has elapsed, power is again supplied to the motor. The motor raises the basket from

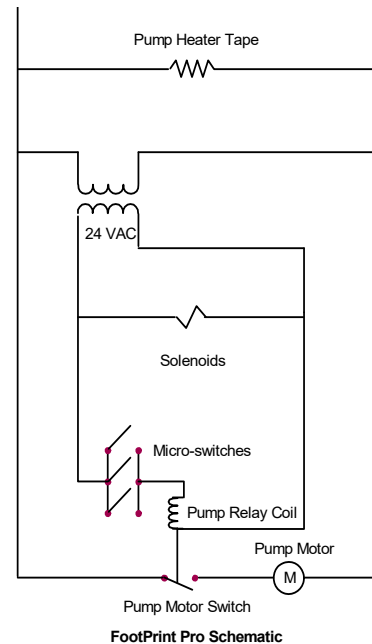

the frypot until the rod loses contact with the upper microswitch, cutting power to the motor and again reversing the direction of current flow.

Problems with the basket lift can be grouped into three categories:

- Binds and jams
- Motors and gears
- Electronics.

BINDS AND JAMS

Noisy, jerky or erratic movement of the lifts is usually due to lack of lubrication of the rods and bushings. Apply a light coat of Lubriplate® or similar lightweight white grease to the rod and bushings to correct the problem.

Another possible cause of binding is improper positioning of the motor, which prevents the gear from correctly engaging the teeth in the rod. To correct the problem, loosen the screws that hold the motor in place and move it forward or backward until the rod has just enough slack to be rotated slightly.

MOTORS AND GEARS

The most likely problem to be encountered in this category is erratic motion of the lift due to a worn drive gear. Failure to keep the lift rod and bushings properly lubricated will cause unnecessary wear of the gear. Correct the problem by replacing the worn gear.

If the lift cycles correctly but fails to remain in the up position (i.e., goes up, but then slowly settles back down into the frypot), the problem is a failed motor brake. This cannot be repaired and the motor must be replaced.

If power is reaching the motor but the motor fails to run, it is burned out and must be replaced.

ELECTRONICS

Within this category are problems associated with the relays, microswitches, capacitors, resistors, interface board, wiring, and controls. The most common problem in this category is a lift that continuously travels up and down. This is usually caused by a microswitch that is out of adjustment.

Troubleshooting the electronics of the basket lift is the process of verifying current flow through the individual components up to and including the motor. Using a multimeter set to the 250 VAC range, check the connections on both sides of the component for the presence of the applied line voltage. The wiring diagram on the Page 1-38 identifies the components and wiring connection points.

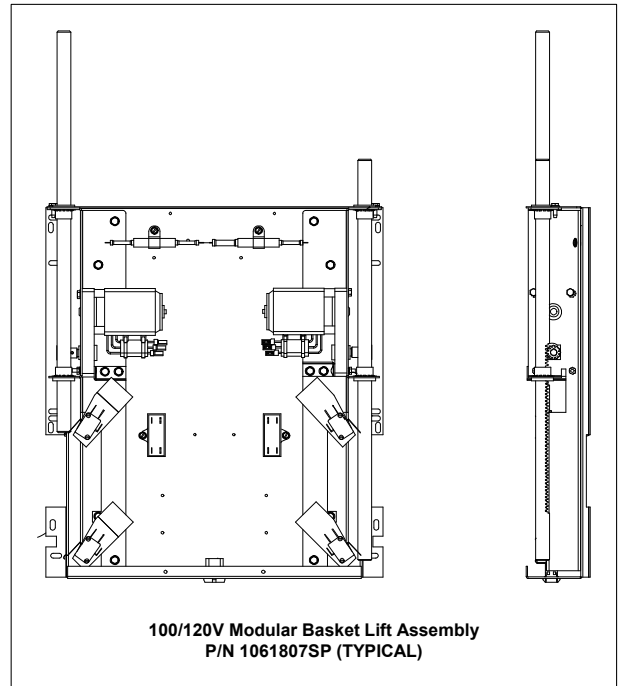

1.7.8 Interpretation of Analog Controller Lights

Power light on, heat light cycling, trouble light off, and melt light on:

- If fryer oil temperature is below 180°F (82°C), the lights indicate the unit is operating normally.
- If the oil temperature is above 180°F (82°C) and the heat light continues to cycle as if in the melt cycle, this may indicate a defective probe circuit or low incoming 12VAC to the controller.

Power light on, heat light on, trouble light off, and melt light off:

- If the fryer oil temperature is above 180°F (82°C) and below the setpoint temperature, the lights indicate the unit is operating properly.
- If the oil temperature is above the temperature set on the control knob and the heat light remains lit, this may indicate a defective probe circuit.

Power light on, heat light off, trouble light on, and melt light off:

- If the fryer oil temperature is below 410°F (210°C), the lights indicate one of the following:
 - a. The probe circuit is defective, or
 - b. There is a connection problem on pins 2 or 10 on the 15-pin wiring harness.
- If the fryer oil temperature is above 410°F (210°C), the lights indicate a run-away heating circuit.

1.8 Troubleshooting Guides

The troubleshooting guides on the following pages are intended to assist service technicians in quickly isolating the probable causes of equipment malfunctions by following a logical, systematic process. An additional set of operator troubleshooting guides is contained in Chapter 6 of the Pro H55-Series Installation and Operation Manual (P/N 819-5991). It is suggested that service technicians thoroughly familiarize themselves with both sets.

1.8.1 Troubleshooting the 24 VAC Circuit

Prior to checking for problems associated with the 24 VAC circuit, ensure that the unit is connected to a power supply, the drain valve is fully closed, and the controller is on and is calling for heat (decimal appears between first two digits in controller display).

NOTE: All voltage measurements must be made within **4 seconds** of the unit calling for heat. If unit does not fire within **4 seconds**, ignition modules will lock out and controller must be turned off, then on to reset.

The following processes will assist you in troubleshooting the 24 VAC circuit and ruling it out as a probable cause:

- **24 VAC is not present on the interface board J3 pin 9 (LED 5 (GV)) and, on dual units, on J1 pin 9 (LED 1 (GV)).**
 1. If LED 3 *is not* continually lit, the probable causes are a failed 24 VAC transformer or failed wiring between transformer and interface board.
 2. If LED 3 *is* continually lit, check the right PWR terminal (LED 4) for 24 VAC. On dual units, also check the left PWR terminal (LED 2) for 24 VAC. Also verify that the F2 fuse is good.
 - a. If 24 VAC *is not* present, the probable causes are a defective heat relay or a failed interface board.
 - b. If 24 VAC *is* present, check for 24 VAC on V1S (or V1D and V2D, if dual unit).
 - i. If 24 VAC *is not* present, check the fuses. If they are good, the probable causes are failed ignition module(s) or a failed interface board. Replace the questionable ignition module with one known to be good to isolate the cause.
 - ii. If 24 VAC *is* present, the probable cause is a failed interface board.
- **24 VAC is present on interface board J3 pin 9 (LED 5 (GV)) and, on dual units, on J1 pin 9 (LED 1 (GV)).**
 1. If 24 VAC *is not* present across the gas valve main coil (MV terminal), probable causes are an open high-limit thermostat or a failed wire between the interface board and gas valve. Be sure to check both valves on dual units. It may also be caused by a failed drain safety switch.

Check continuity of high-limit thermostat and drain safety switch. If both are zero, problem is in wiring.
 2. If 24 VAC *is* present across the gas valve main coil (MV terminal), the 24 VAC circuit is working, and the problem may be with the gas valve. Be sure to check both valves on dual units.

24 VOLT CIRCUIT

With Interface Board 106-0386 and
One 807-3366 (FV) Ignition Module

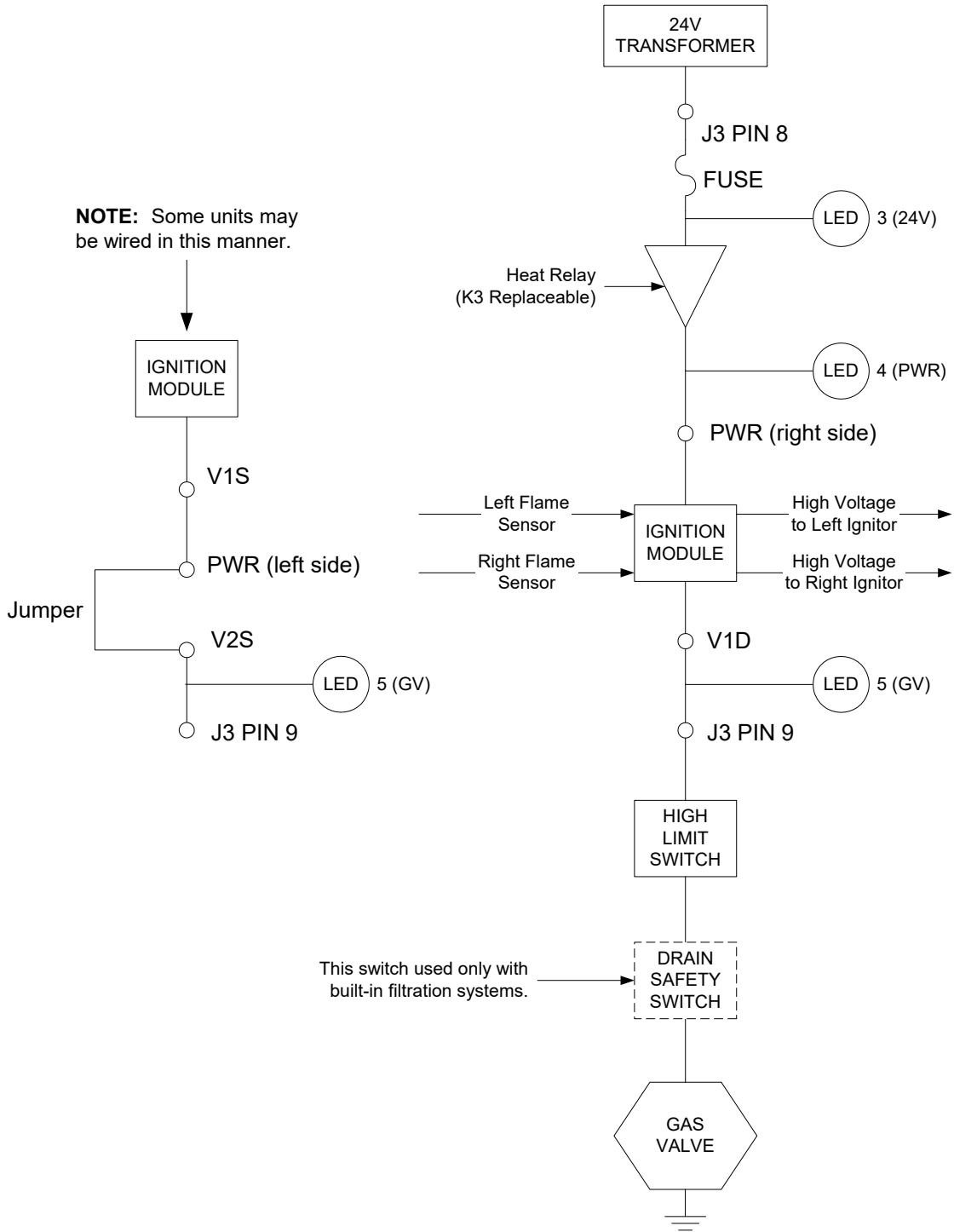

24 VOLT CIRCUIT

With Interface Board 106-0386 and Two 807-3365 (DV) Ignition Modules

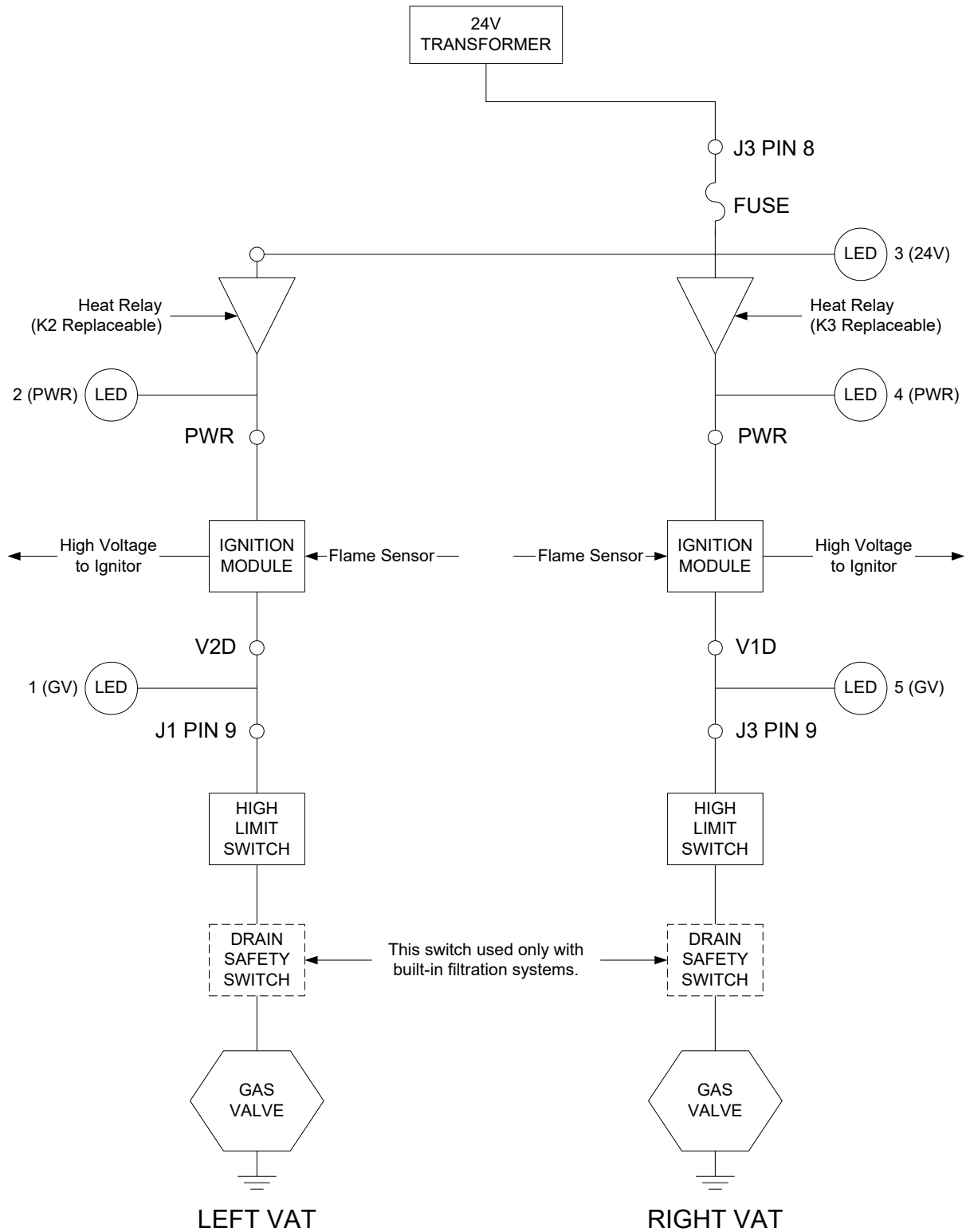

1.8.2 Troubleshooting the Gas Valve

Prior to checking for problems associated with the gas valve, ensure that the unit is calling for heat. Also, for non-CE units, verify that the gas valve is in the ON position.

The following processes will assist you in troubleshooting the gas valve and ruling it out as a probable cause:

- If 24 VAC is not present across gas valve main coil, the probable cause is the 24 VAC circuit. Refer to the 24 VAC circuit troubleshooting guide.
- If 24 VAC is present across gas valve main coil, check the incoming gas pressure and compare to the tables in Section 2.3 of the Installation and Operation manual.
 1. If incoming gas pressure *is not* correct, the probable cause is a problem with the gas supply to fryer.
 2. If incoming gas pressure *is* correct, check the outgoing gas pressure and compare it to the tables on page 2-4 or 2-5 of the Installation and Operation manual.
 - a. If outgoing gas pressure *is not* correct, the probable cause is an improperly adjusted or failed gas valve. Adjust the valve by following the procedure “Check Burner Manifold Pressure” in Section 1.4 of this manual.

If the valve cannot be adjusted, replace it.

- b. If outgoing gas pressure *is* correct, the gas valve is okay.

1.8.3 Troubleshooting the Temperature Probe

Prior to checking for problems associated with the temperature probe, inspect the probe body for damage while it is still in the frypot. Remove and replace the probe if it is bent, dented, or cracked. Also, inspect leads for fraying, burning, breaks, and/or kinks. If found, replace the probe.

The following processes will assist you in troubleshooting the gas valve and ruling it out as a probable cause:

Before testing the probe, unplug the 15-pin connector from the controller to prevent unwanted interference. Determine the temperature the cooking oil using another thermometer or pyrometer placed at the tip of the questionable probe.

- **If resistance through J3 pins 2 and 6 (J1 pins 2 and 6 for left side of dual unit) is not approximately equal to that given in the Probe Resistance Chart for the corresponding temperature, the probe has failed and must be replaced.**
- **If resistance through J3 pins 2 and 6 (J1 pins 2 and 6 for left side of dual unit) is approximately equal to that given in the Probe Resistance Chart for the corresponding temperature, measure the resistance through each of the previously tested pins to ground.**

1. If resistance *is not* 5 mega-Ohms or greater between each pin and chassis ground, the probe has failed and must be replaced.
2. If resistance *is* 5 mega-Ohms or greater between each pin and chassis ground, the probe is okay.

1.8.4 Probe Resistance Charts

<h2 style="text-align: center;">Probe Resistance Chart</h2> <p style="text-align: center;"><i>For use with Pro Series fryers manufactured with Minco Thermistor probes only.</i></p>																	
F	OHMS	C	F	OHMS	C	F	OHMS	C	F	OHMS	C	F	OHMS	C	F	OHMS	C
60	1059	16	130	1204	54	200	1350	93	270	1493	132	340	1634	171			
65	1070	18	135	1216	57	205	1361	96	275	1503	135	345	1644	174			
70	1080	21	140	1226	60	210	1371	99	280	1514	138	350	1654	177			
75	1091	24	145	1237	63	215	1381	102	285	1524	141	355	1664	179			
80	1101	27	150	1247	66	220	1391	104	290	1534	143	360	1674	182			
85	1112	29	155	1258	68	225	1402	107	295	1544	146	365	1684	185			
90	1122	32	160	1268	71	230	1412	110	300	1554	149	370	1694	188			
95	1133	35	165	1278	74	235	1422	113	305	1564	152	375	1704	191			
100	1143	38	170	1289	77	240	1432	116	310	1574	154	380	1714	193			
105	1154	41	175	1299	79	245	1442	118	315	1584	157	385	1724	196			
110	1164	43	180	1309	82	250	1453	121	320	1594	160	390	1734	199			
115	1174	46	185	1320	85	255	1463	124	325	1604	163	395	1744	202			
120	1185	49	190	1330	88	260	1473	127	330	1614	166	400	1754	204			
125	1195	52	195	1340	91	265	1483	129	335	1624	168	405	1764	207			

<h2 style="text-align: center;">FAST Probe Resistance Chart</h2> <p style="text-align: center;"><i>For use with Pro Series fryers with a FAST controller and probe only.</i></p>					
° Fahrenheit	Ohms (± 3%)	° Celsius	° Fahrenheit	Ohms (± 3%)	° Celsius
70	108130	21	240	4030	116
80	84606	27	250	3441	121
90	66721	32	260	2967	127
100	53020	38	270	2583	132
110	42452	43	280	2255	138
120	34206	49	290	1977	143
130	27735	54	300	1729	149
140	22641	60	310	1496	154
150	18588	66	320	1320	160
160	15349	71	330	1170	166
170	12741	77	340	1051	171
180	10635	82	350	942	177
190	8925	88	360	840	182
200	7527	93	370	750	188
210	6391	99	380	676	193
220	5470	104	390	605	199
230	4705	110	400	541	204

1.9. Simplified Wiring Diagrams

1.9.1 Wiring Diagram for Full-Vat Dual-Spark Module

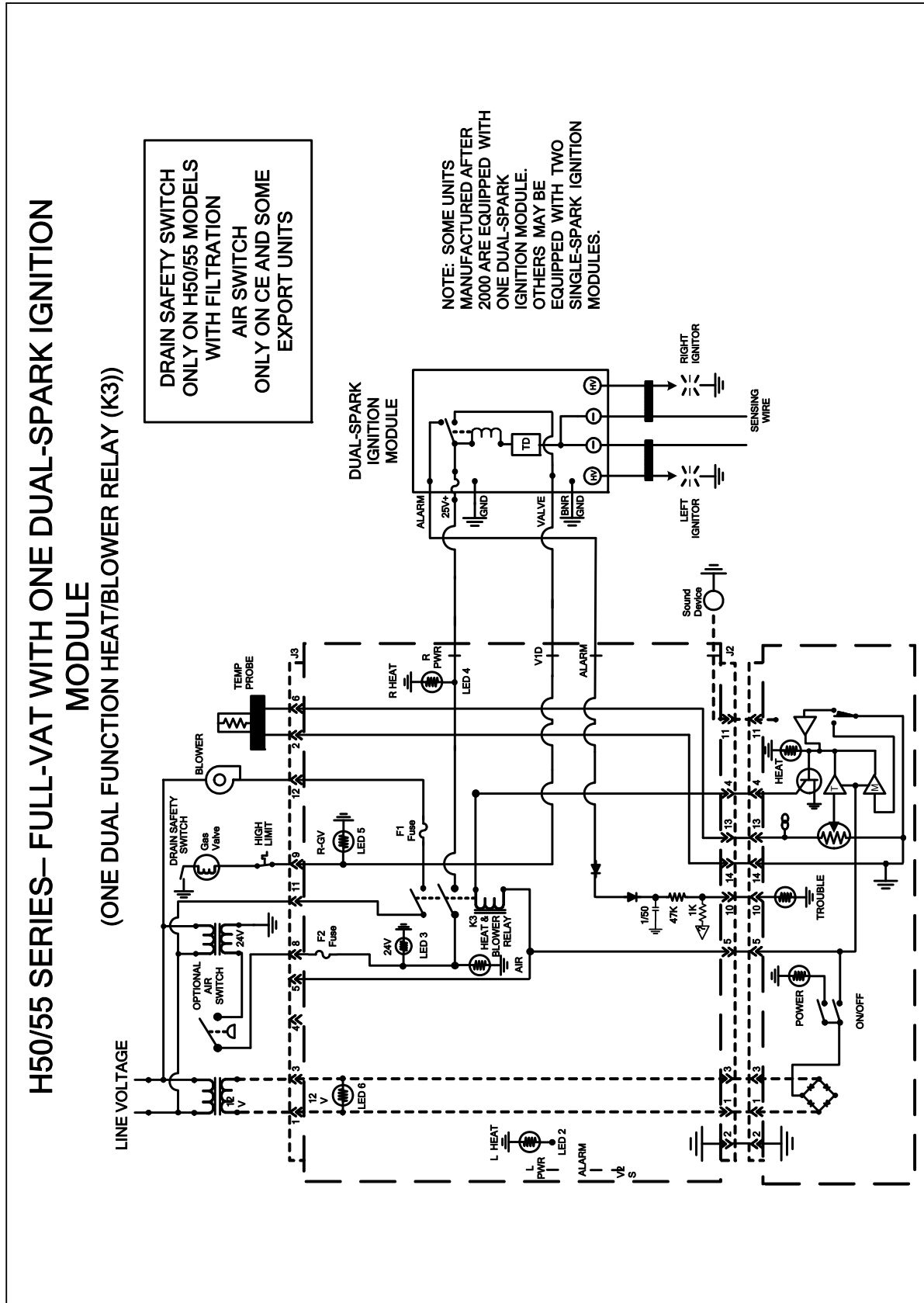

1.9.2 Wiring Diagram for Full-Vat Single-Spark Module (Australia and Pacific Rim)

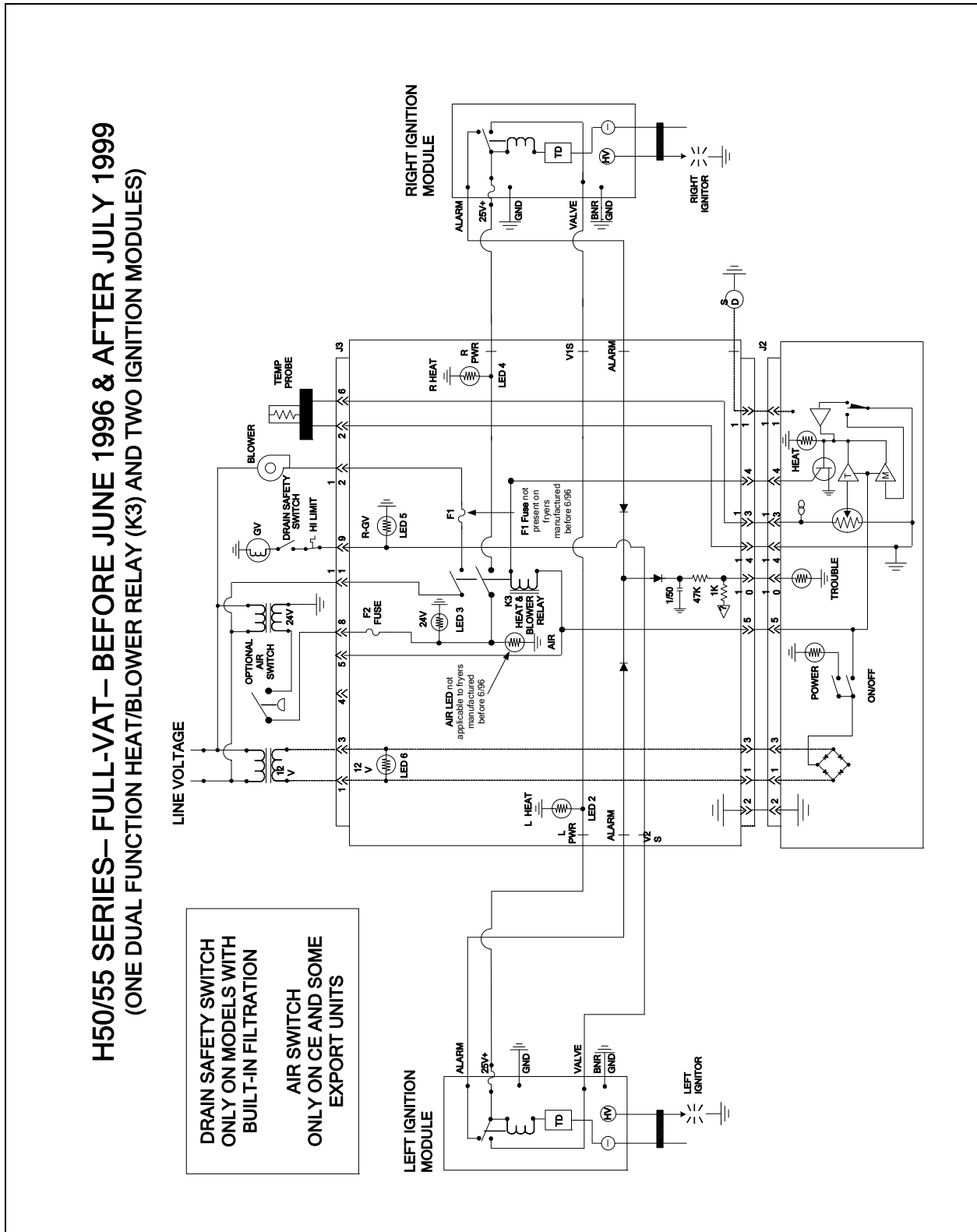

1.9.3 Wiring Diagram for Dual-Vat Single-Spark Module

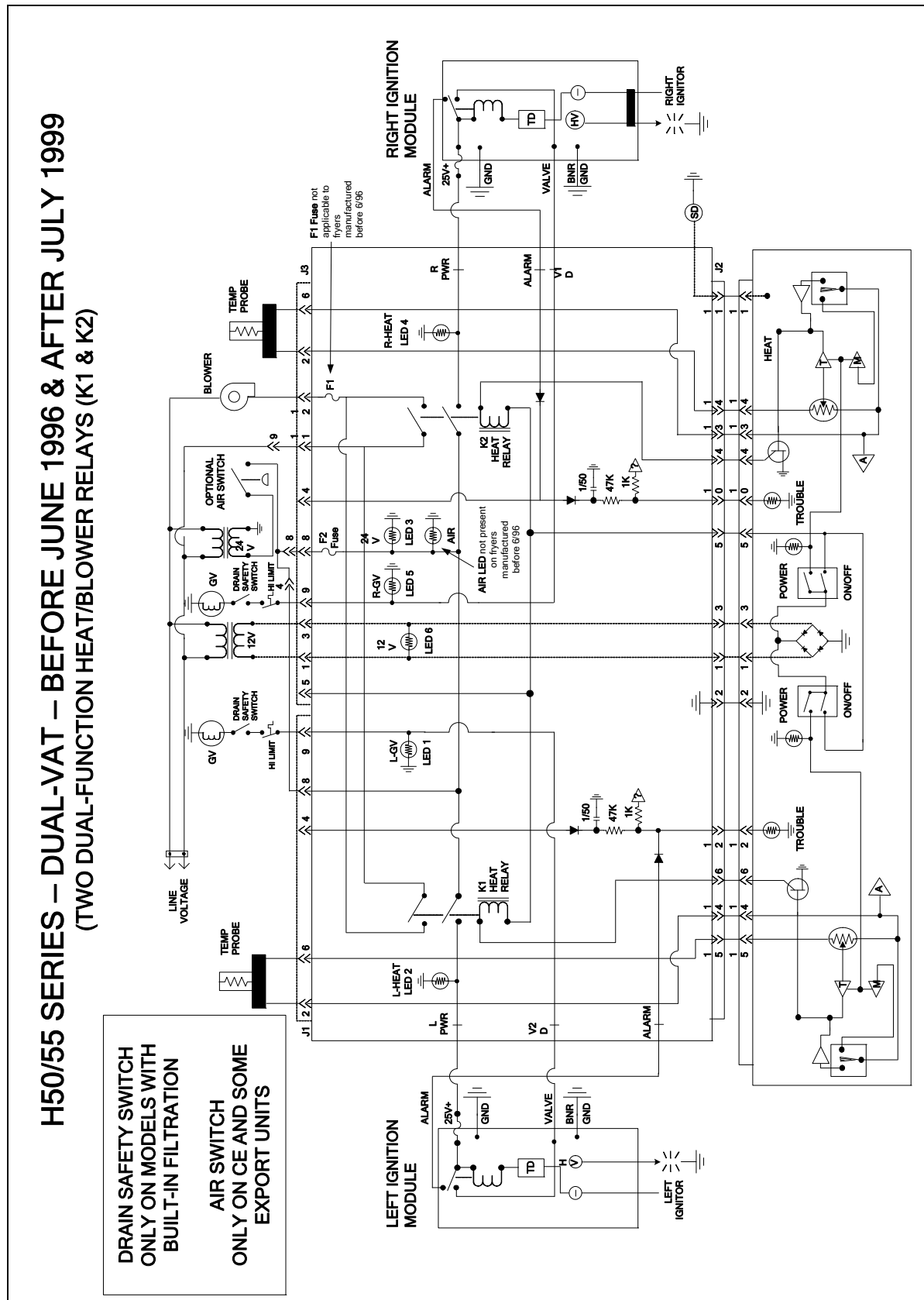

1.10 Principal Wiring Connections

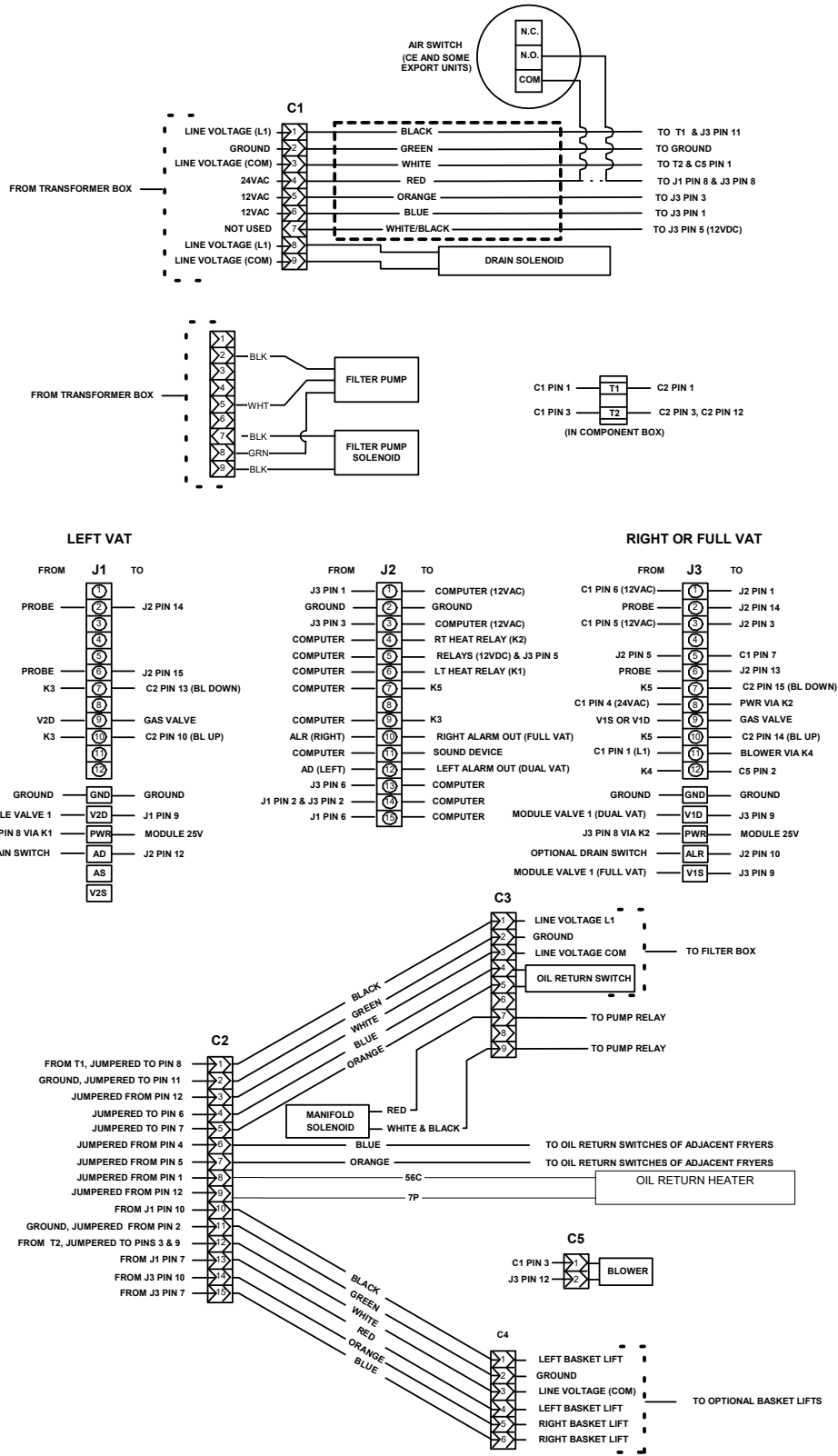

1.11 Wiring Diagrams

1.11.1 Pro H50/55-Series Fryer, Multi-vat, Honeywell

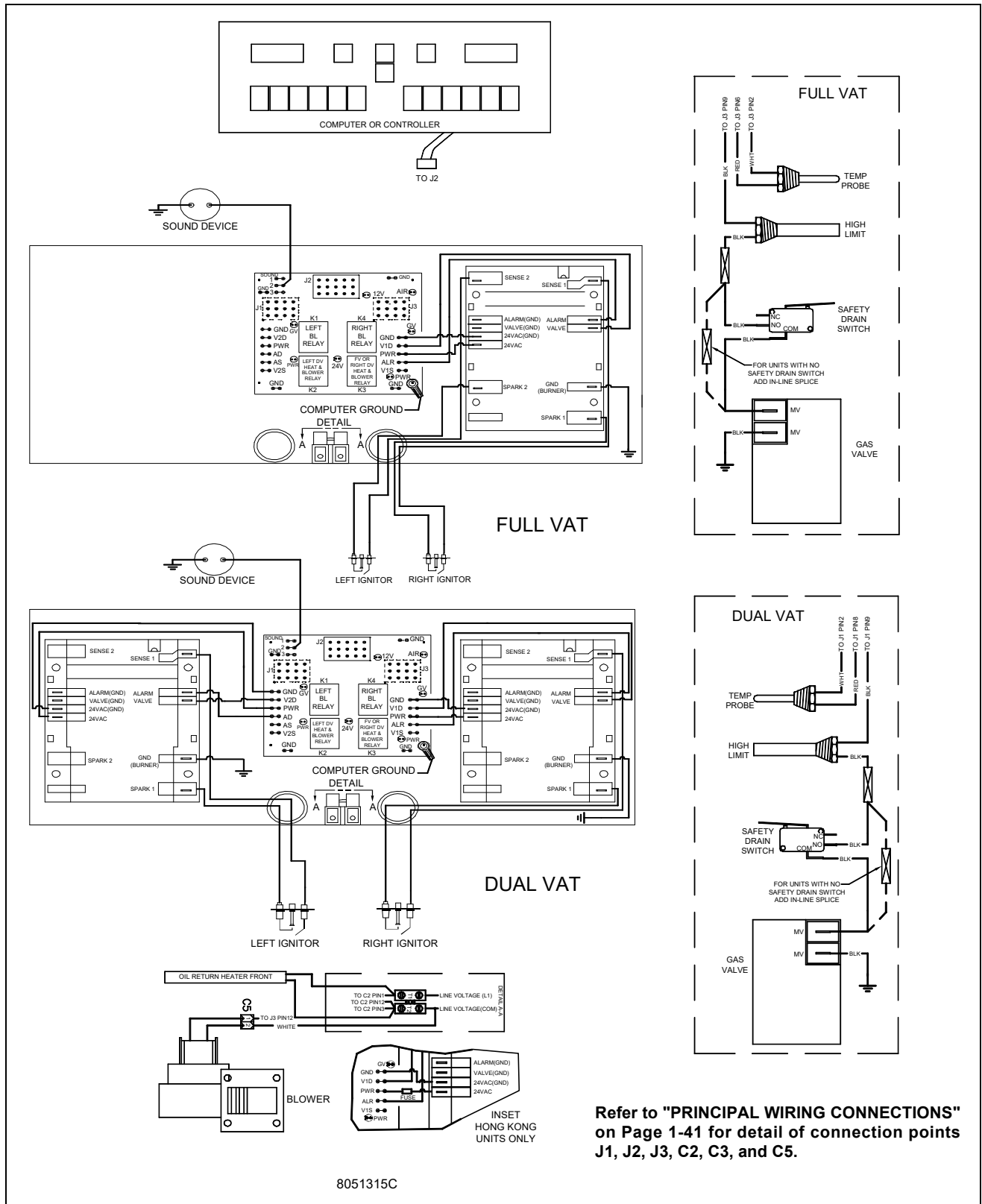

Refer to "PRINCIPAL WIRING CONNECTIONS" on Page 1-41 for detail of connection points J1, J2, J3, C2, C3, and C5.

1.11.2 Pro H50/55-Series Fryer, Single, Full-vat, Honeywell

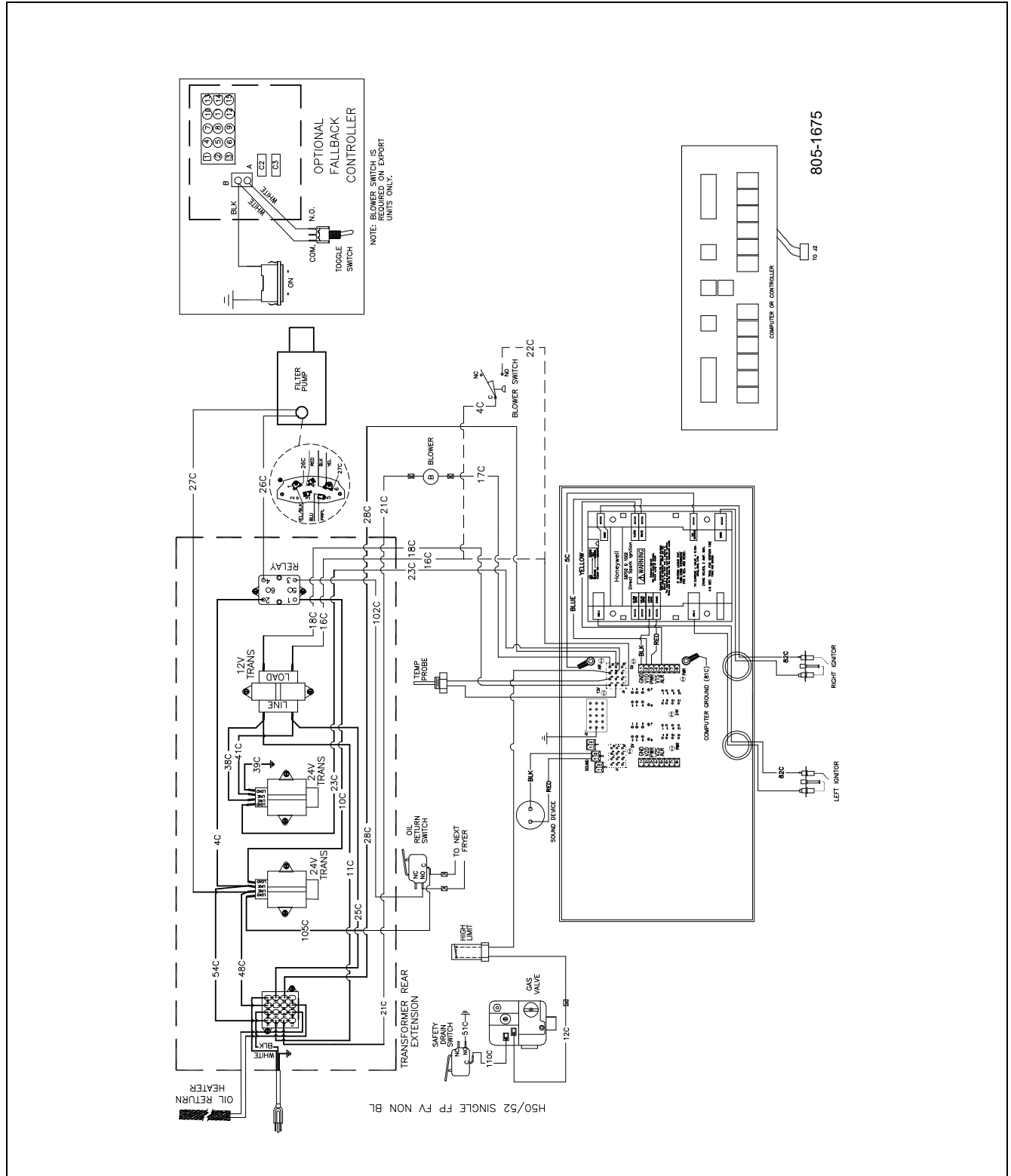

1.11.2.1 Pro H50/55-Series Fryer, Single, Full-vat, Fenwal

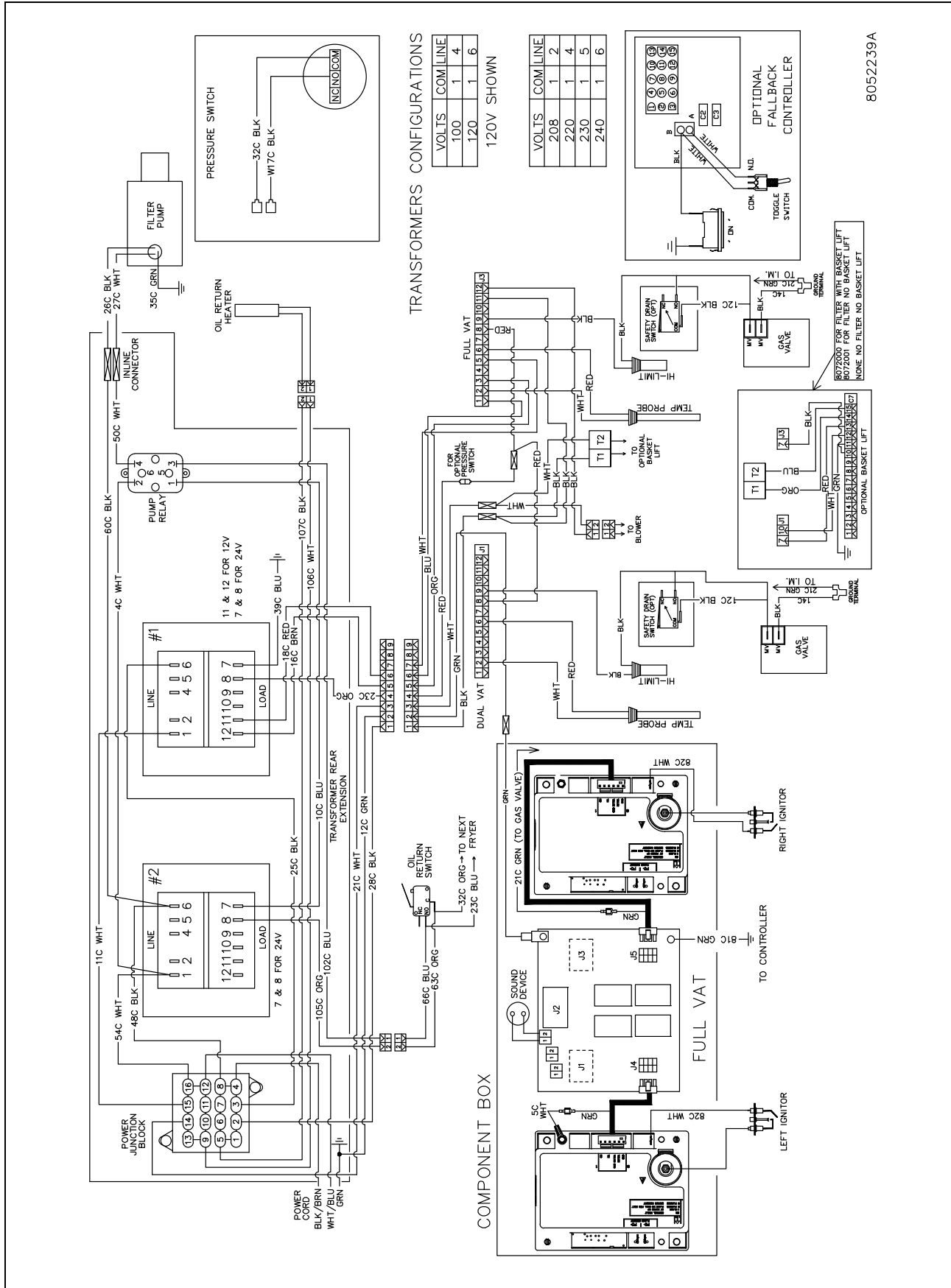

1.11.3 Pro H50/55-Series Fryer, Single, Dual-vat, Honeywell

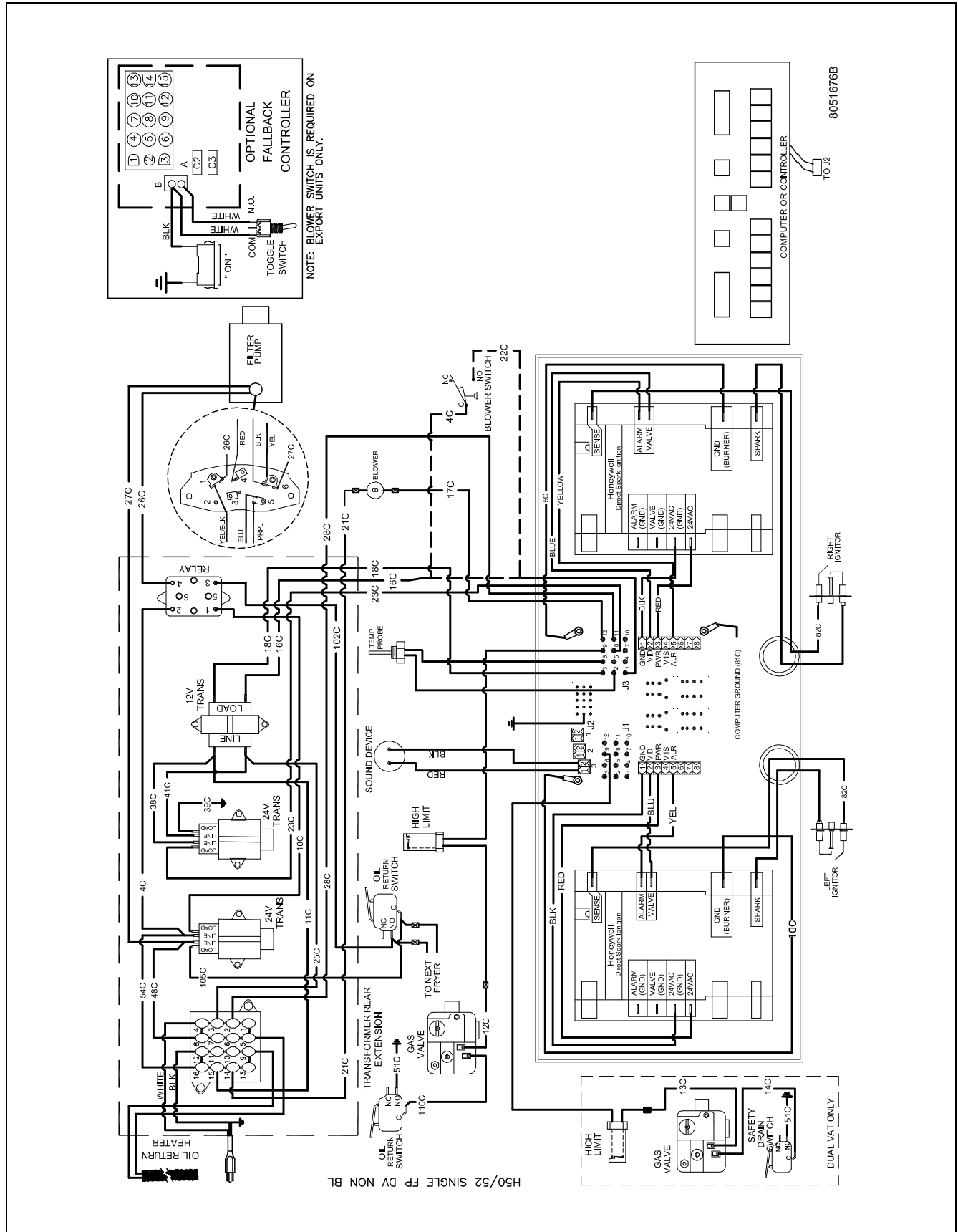

1.11.3.1 Pro H50/55-Series Fryer, Single, Dual-vat, Fenwal

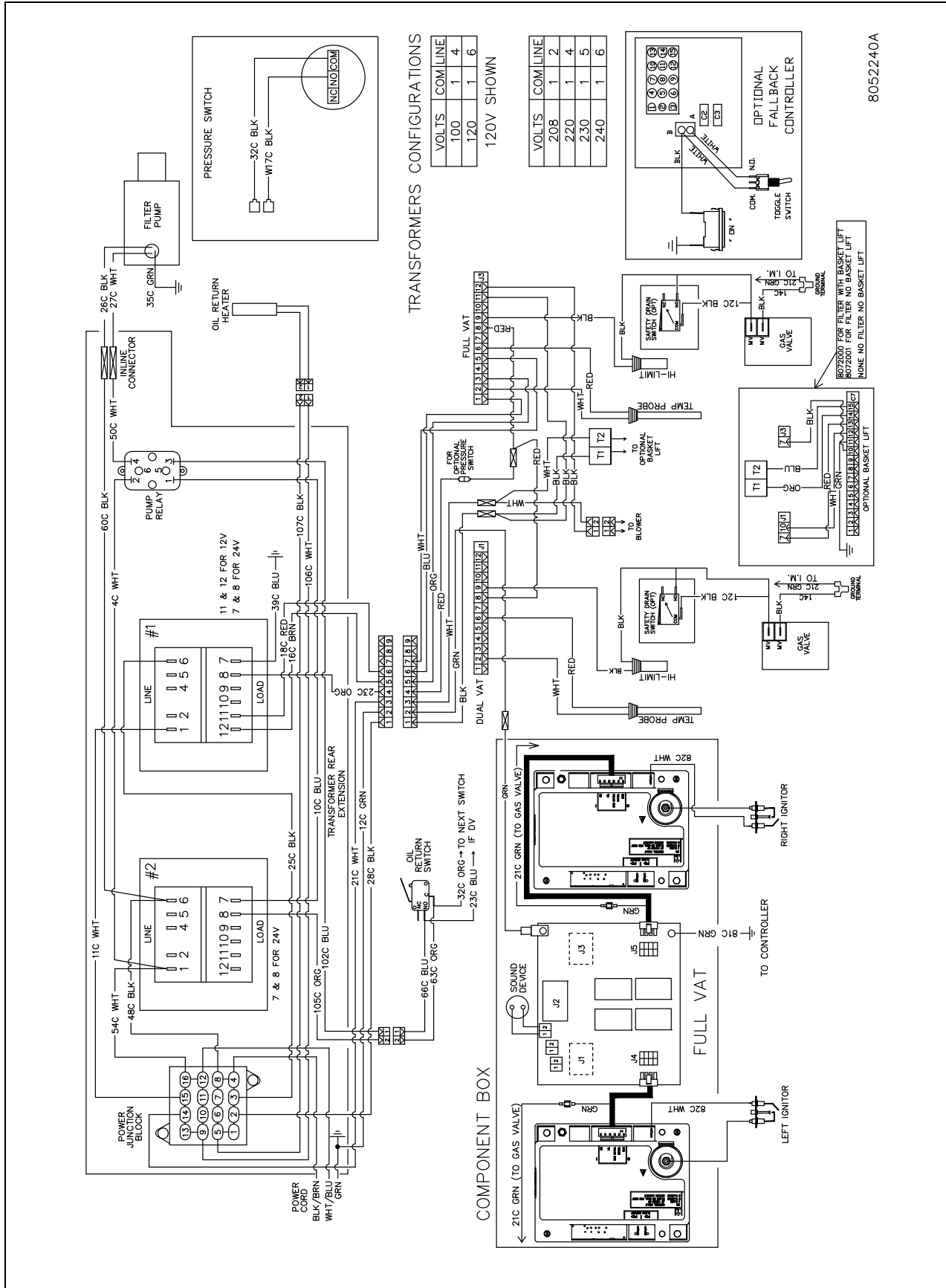

1.11.4 Pro H50/55-Series Fryer, Single, CE, Honeywell

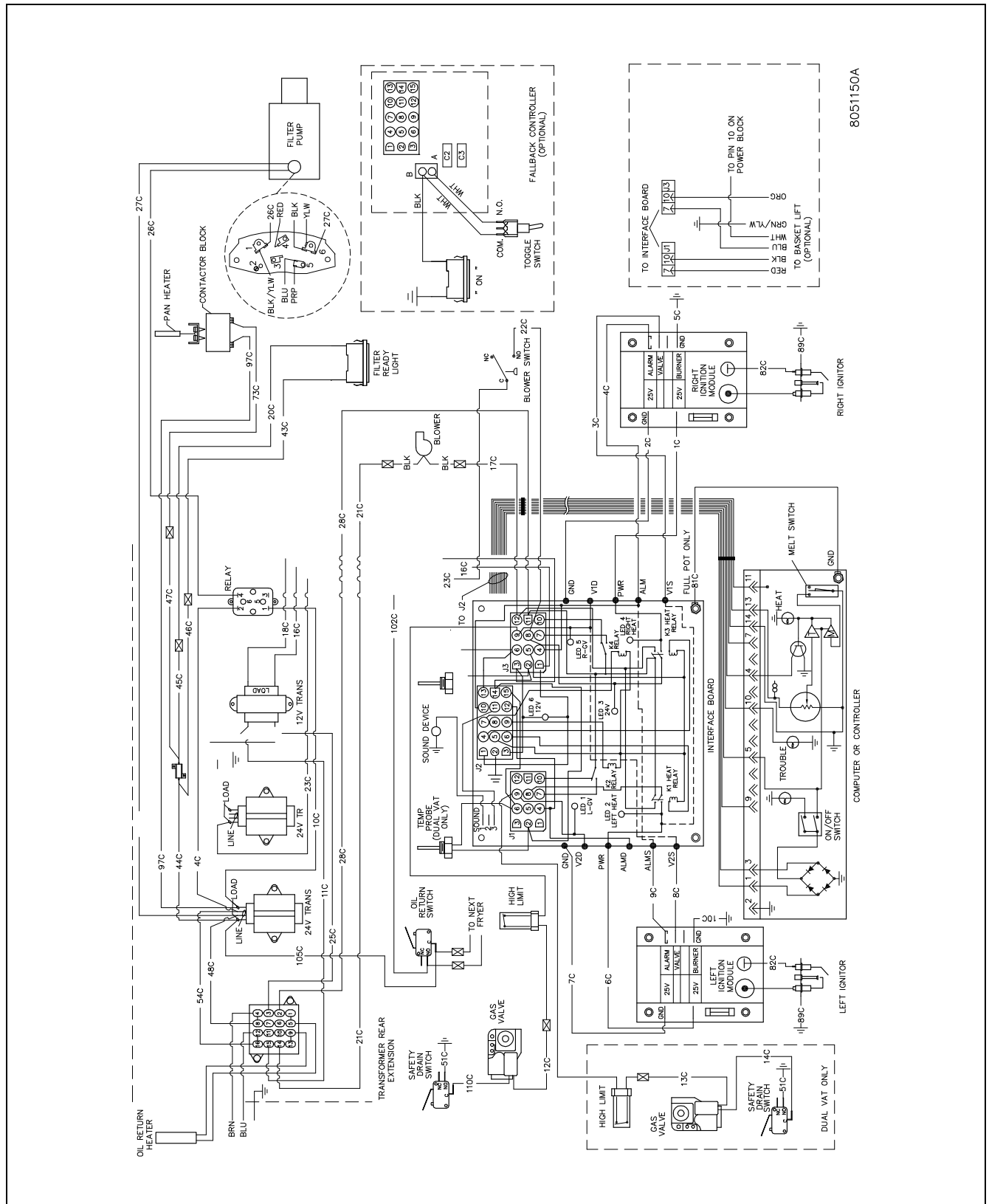

8051150A

1.11.4.1 Pro H50/55-Series Fryer, Single, CE, Fenwal

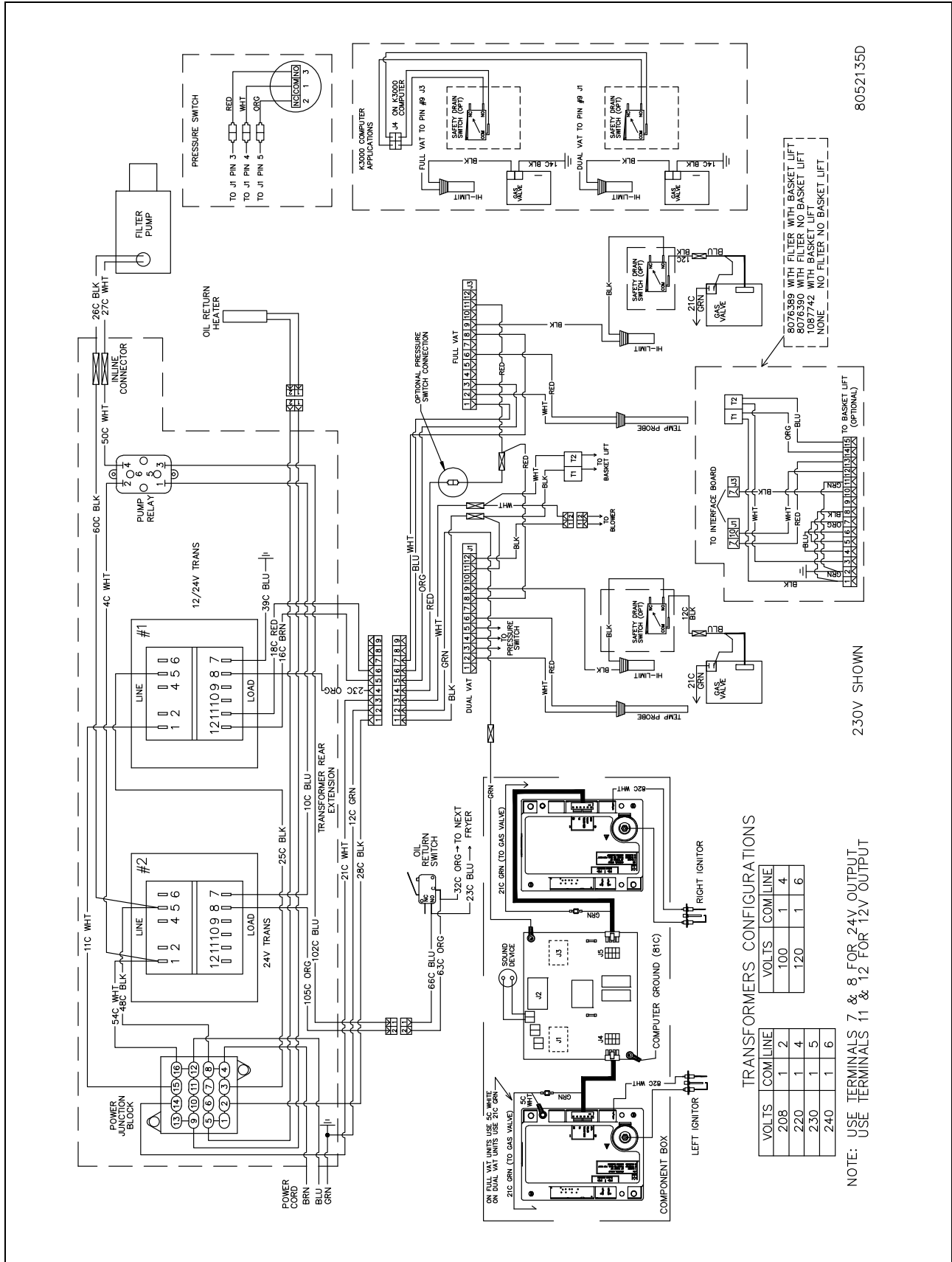

8052135D

230V SHOWN

1.11.5 Pro H50/55-Series Fryer, Single, FAST-ready, Honeywell

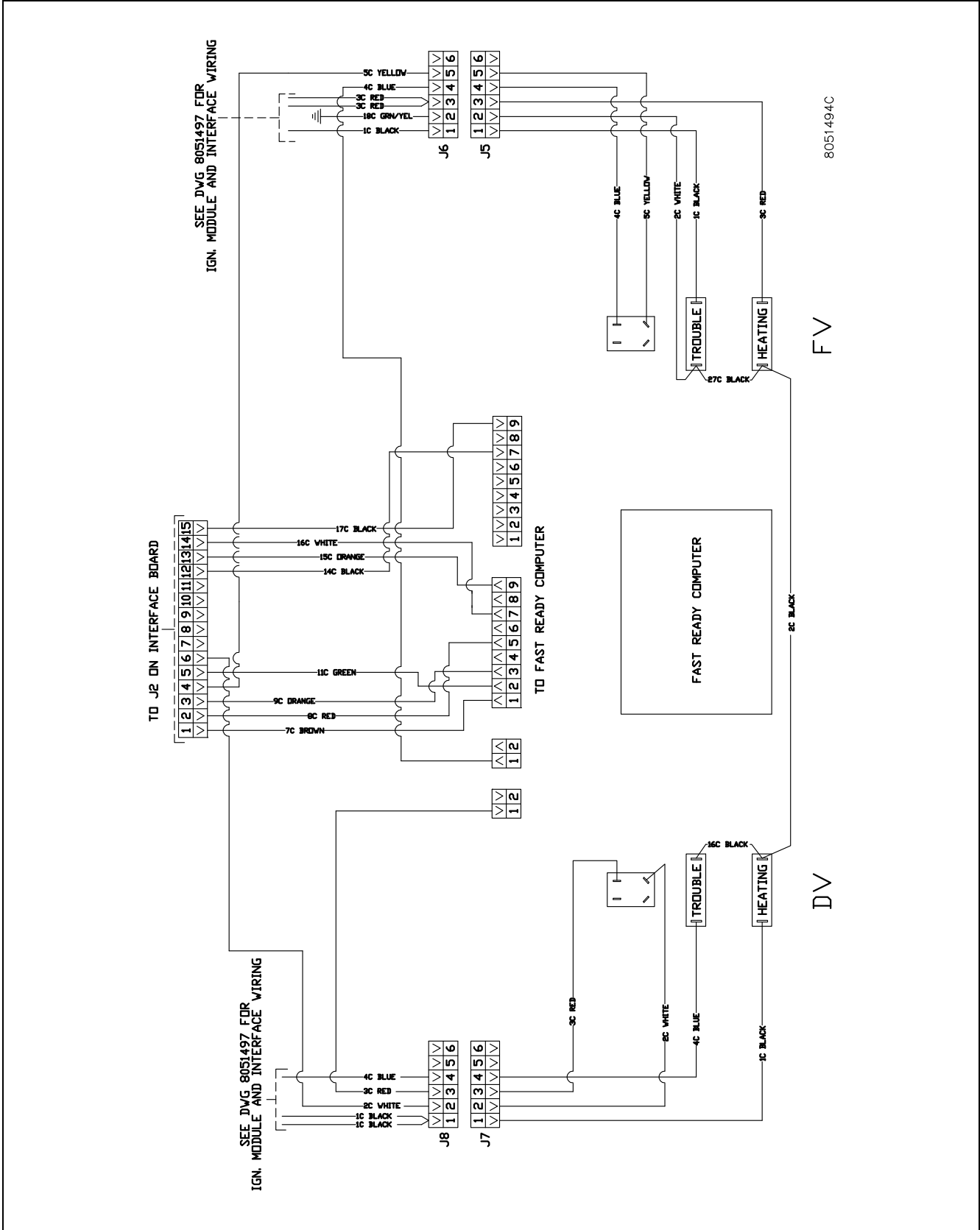

1.11.5.1 Pro H50/55-Single w/out Filter, FAST-ready, Fenwal

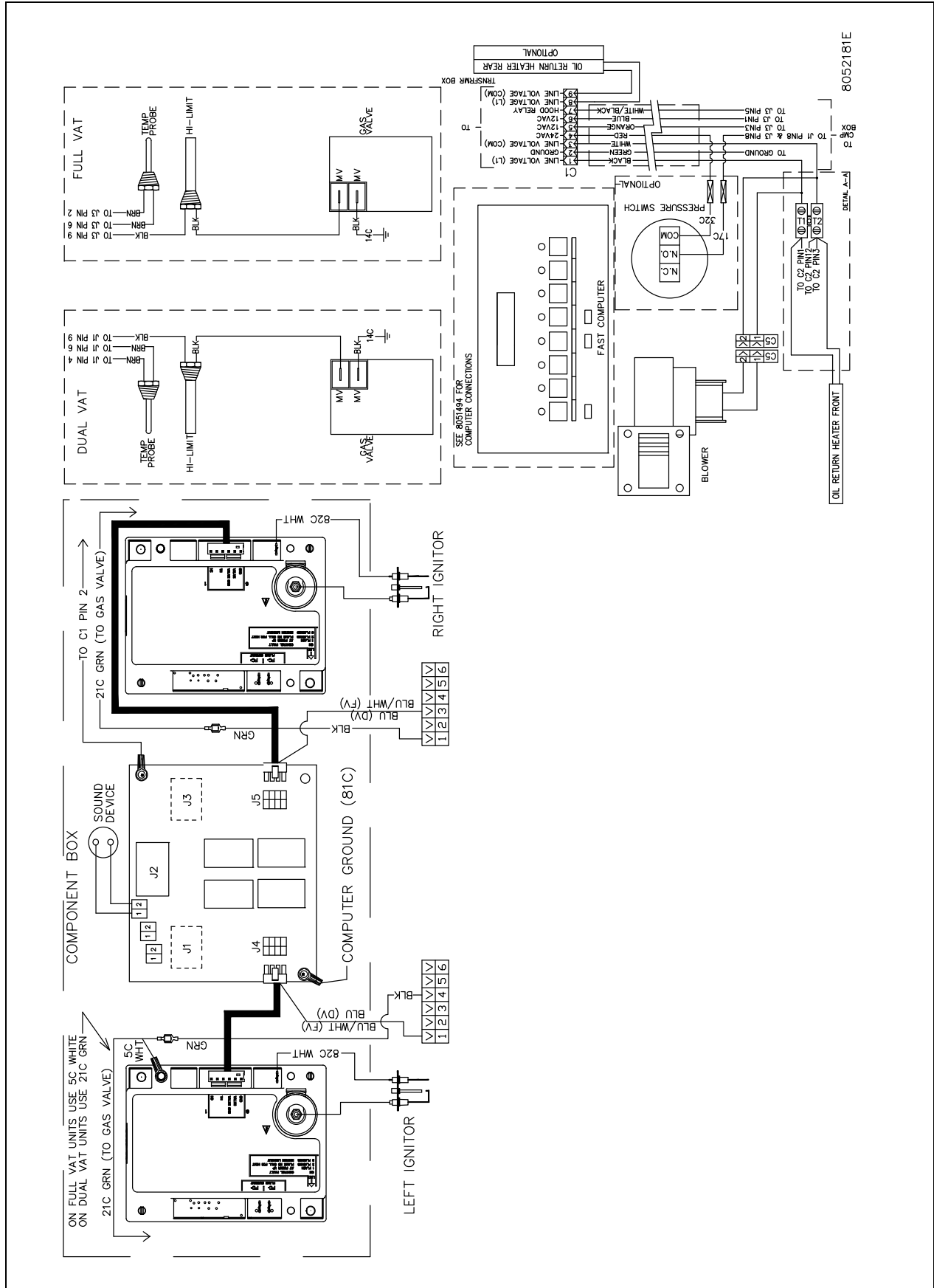

1.11.5.2 Pro H50/55-Single w/Filter, FAST-ready, Fenwal

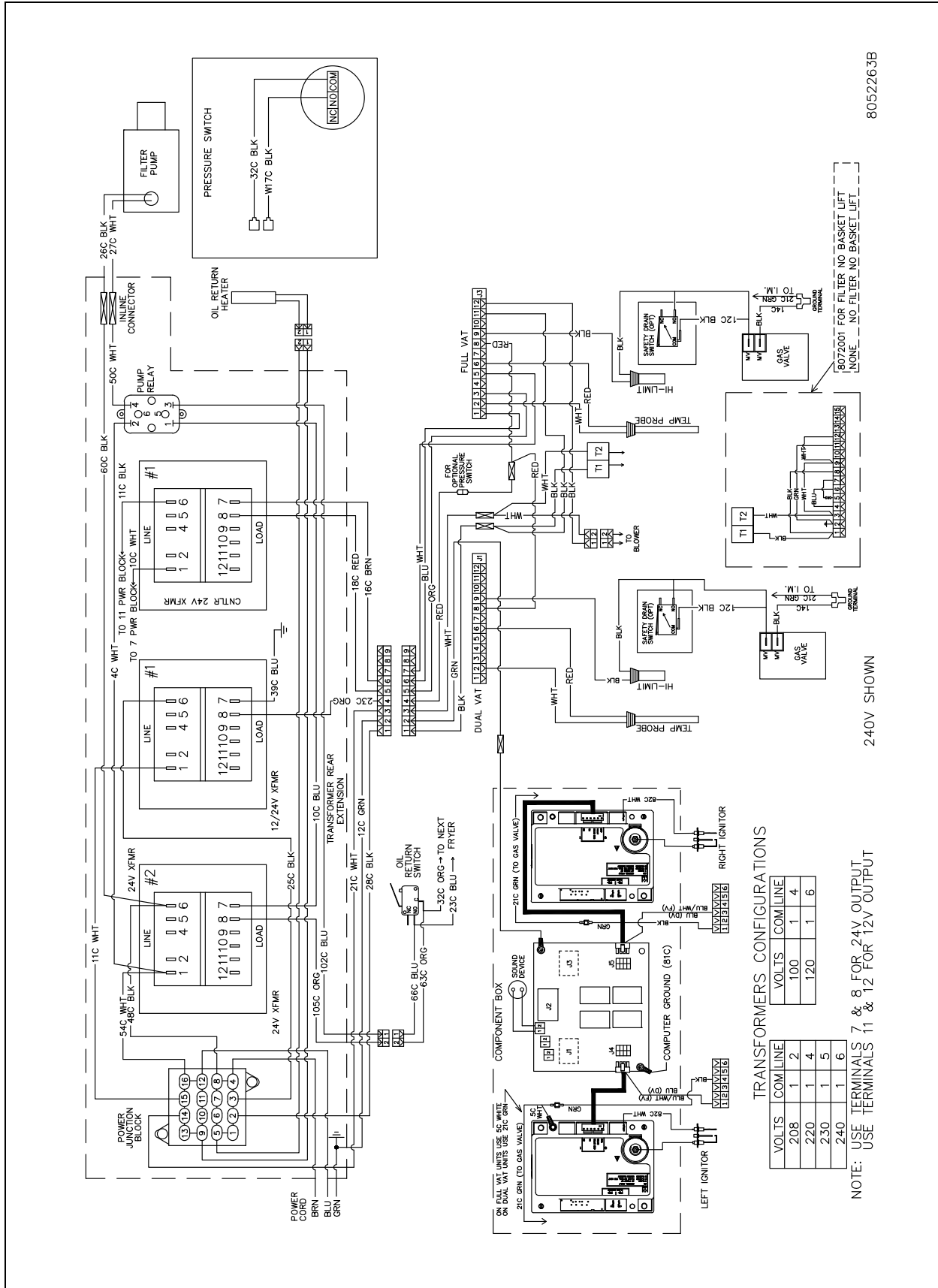

8052263B

1.11.5.5 Pro H50/55-Single w/Filter, FAST-ready, CE, Fenwal

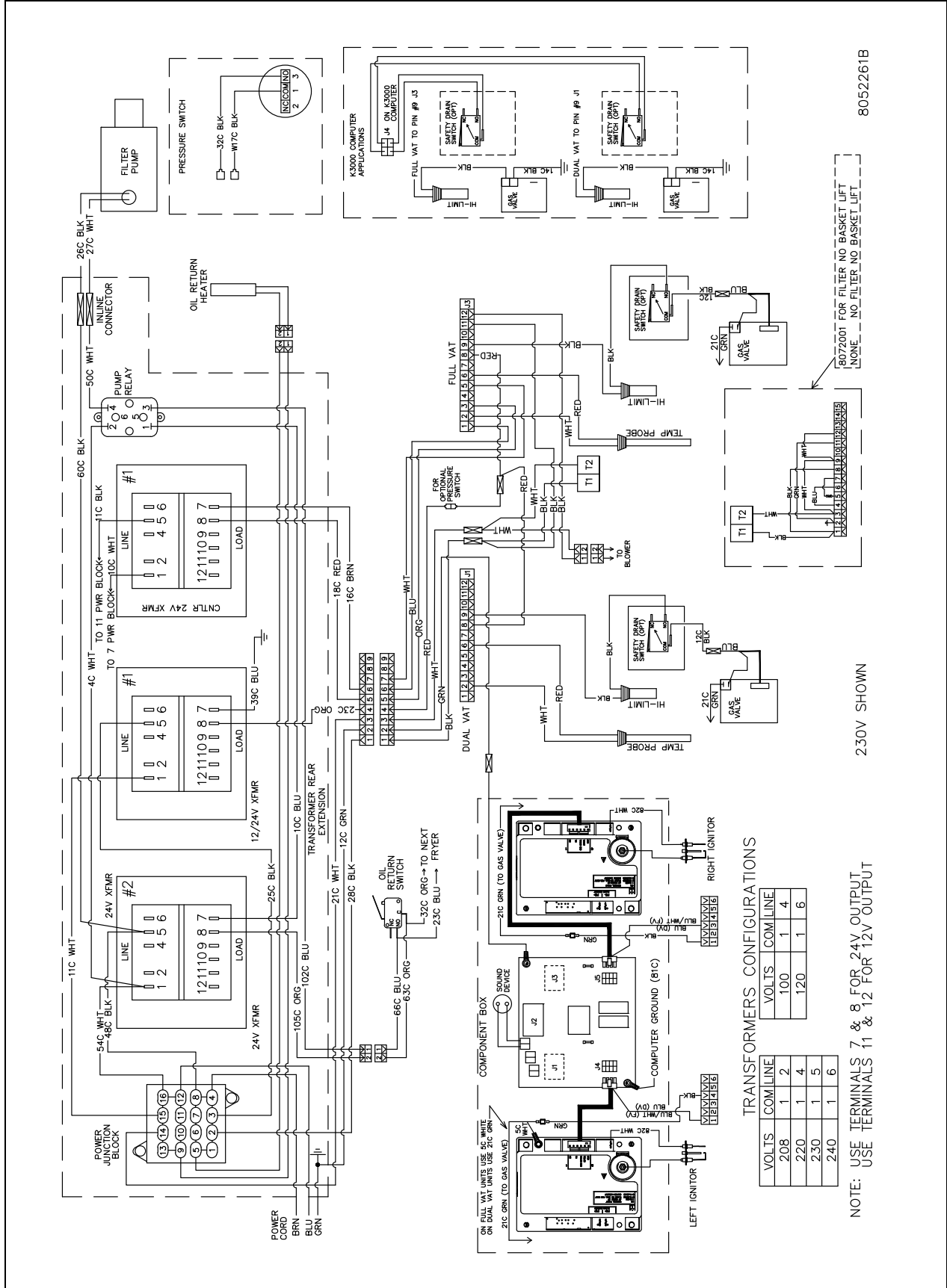

8052261B

230V SHOWN

8072001 FOR FILTER NO BASKET LIFT
NONE _ NO FILTER NO BASKET LIFT

1.11.5.6 Pro H50/55 Multi-vat, FAST-ready, CE, Fenwal

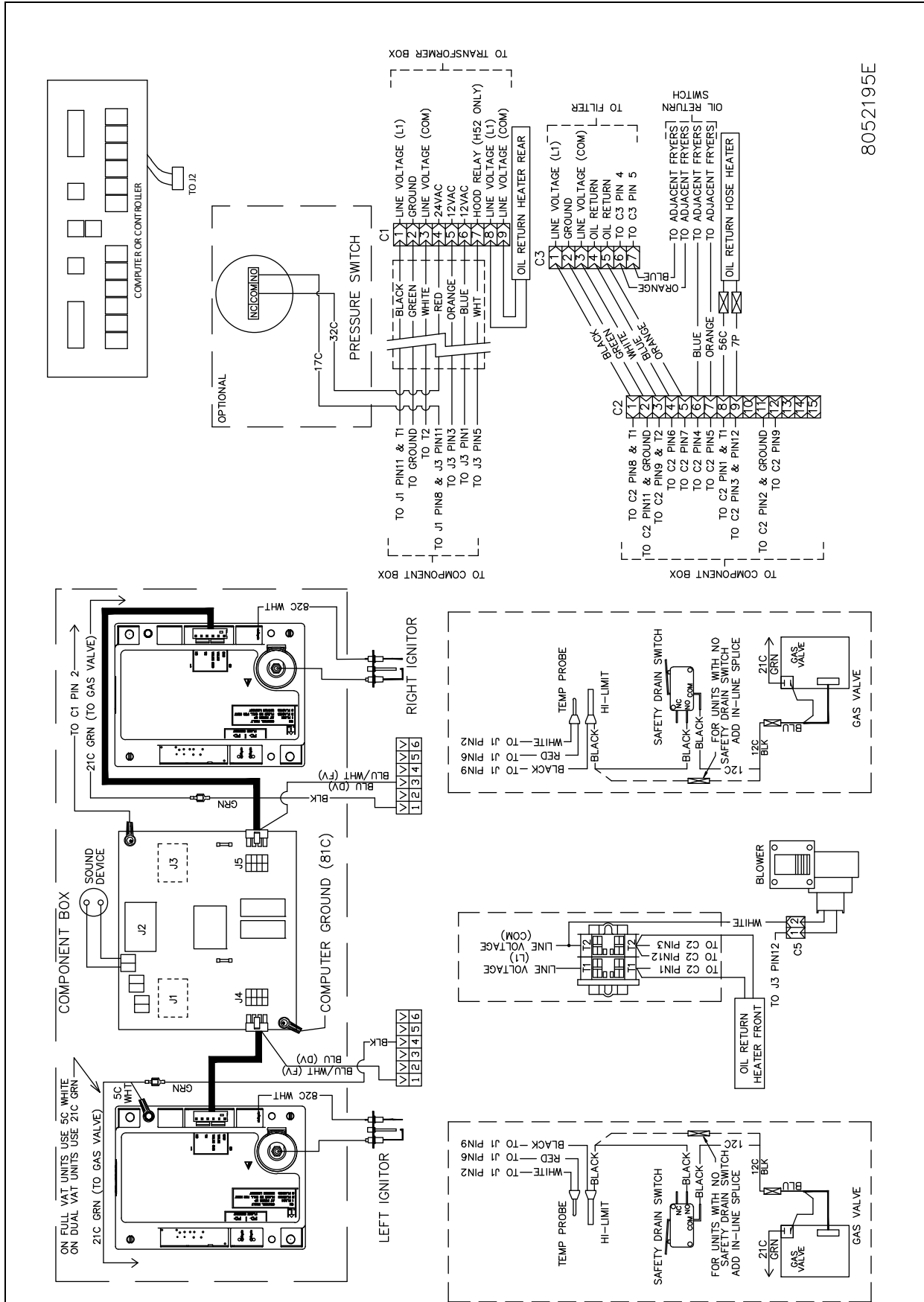

8052195E

1.11.7 Pro H50/55-Series Fryer, Single, Australia

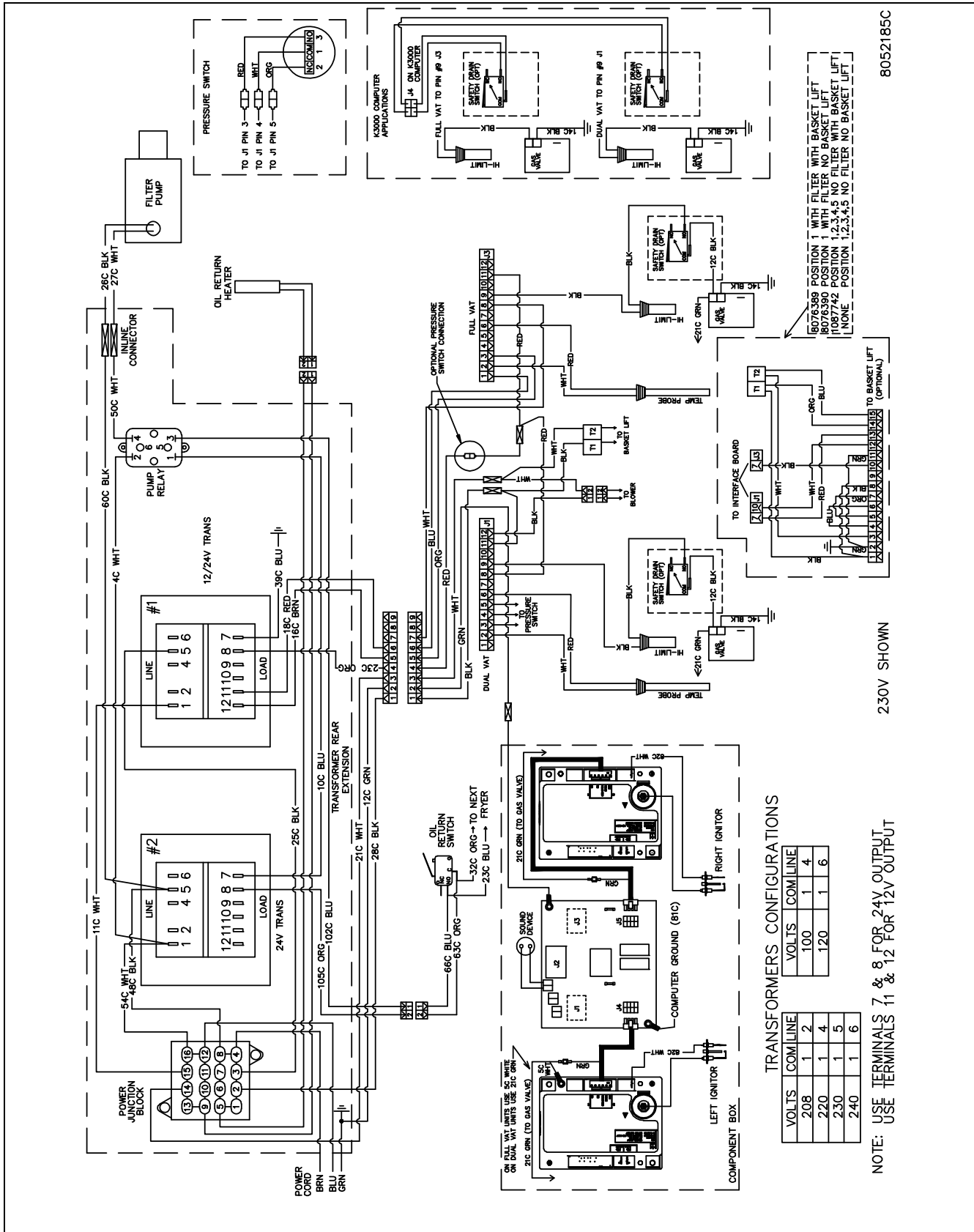

8052185C

230V SHOWN

1.11.8 Transformer/Filter Boxes

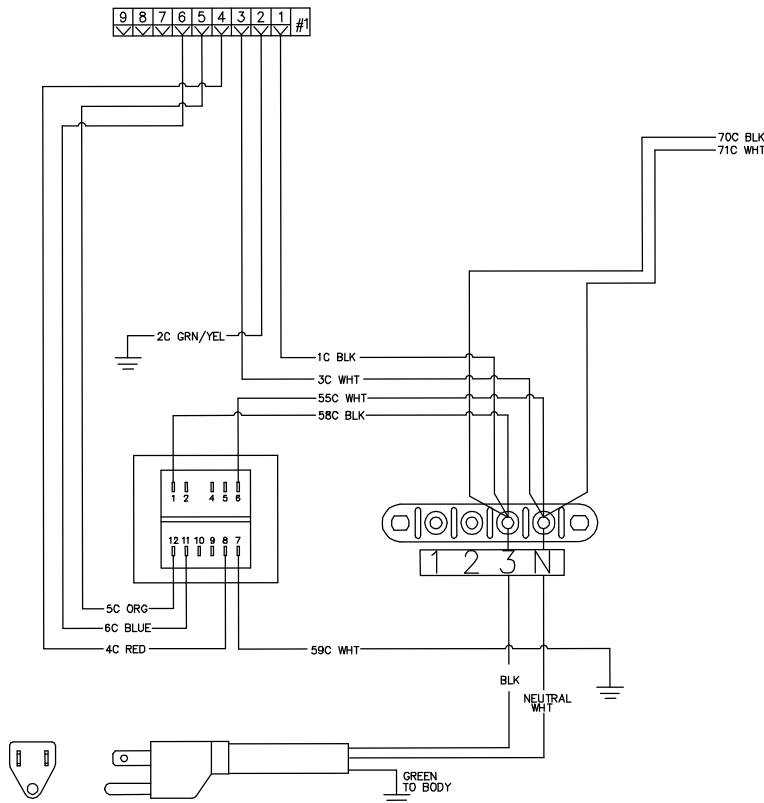

1.11.8.1 MPH150/155 Transformer/Filter Box

VOLTS	COM	LINE
100	1	4
120	1	6
208	1	2
220	1	4
230	1	5
240	1	6

120V CONFIGURATION SHOWN

NOTE: USE TERMINALS 7 & 8 FOR 24V OUTPUT.
USE TERMINALS 11 & 12 FOR 12V OUTPUT

EXTRACTED FROM 8051377B

1.11.8.2 FPH150/155 Transformer/Filter Box

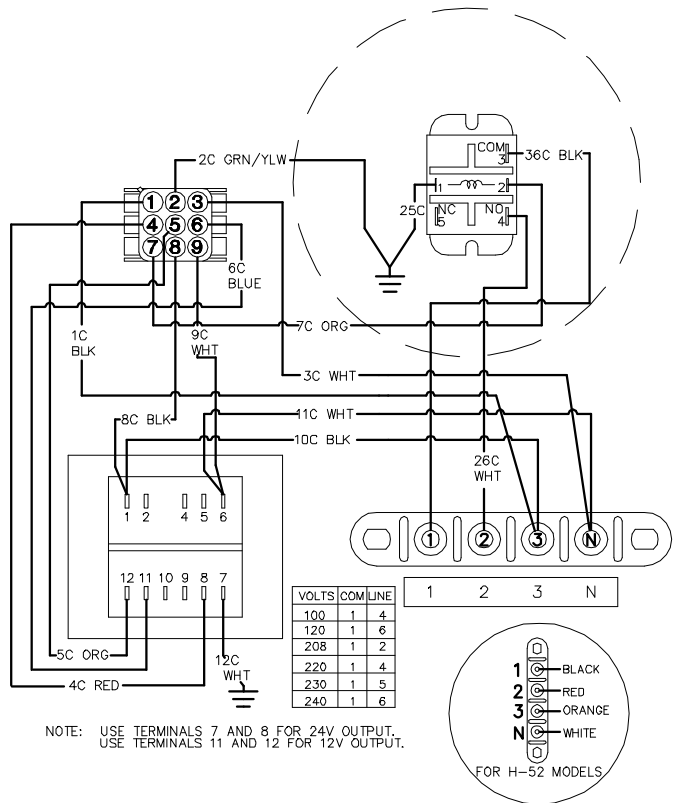

VOLTS	COM	LINE
100	1	4
120	1	6
208	1	2
220	1	4
230	1	5
240	1	6

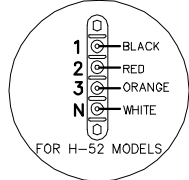

NOTE: USE TERMINALS 7 AND 8 FOR 24V OUTPUT.
USE TERMINALS 11 AND 12 FOR 12V OUTPUT.

805-0504

120 Volt Configuration

1.11.8.3 FPPH 250/255/450/455 Transformer/Filter Box

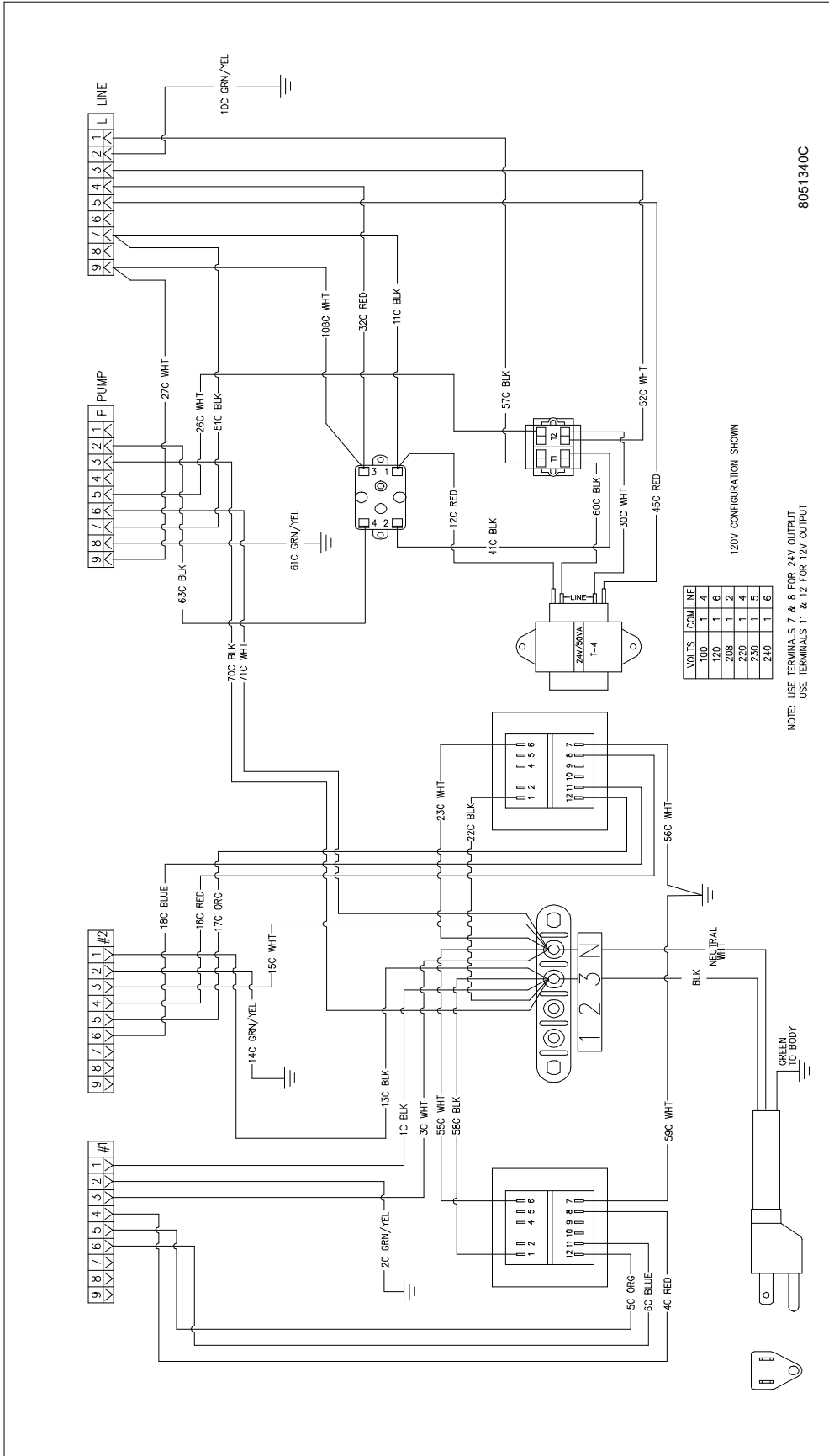

8051340C

1.11.8.4 FPPH 350/355 Transformer/Filter Box

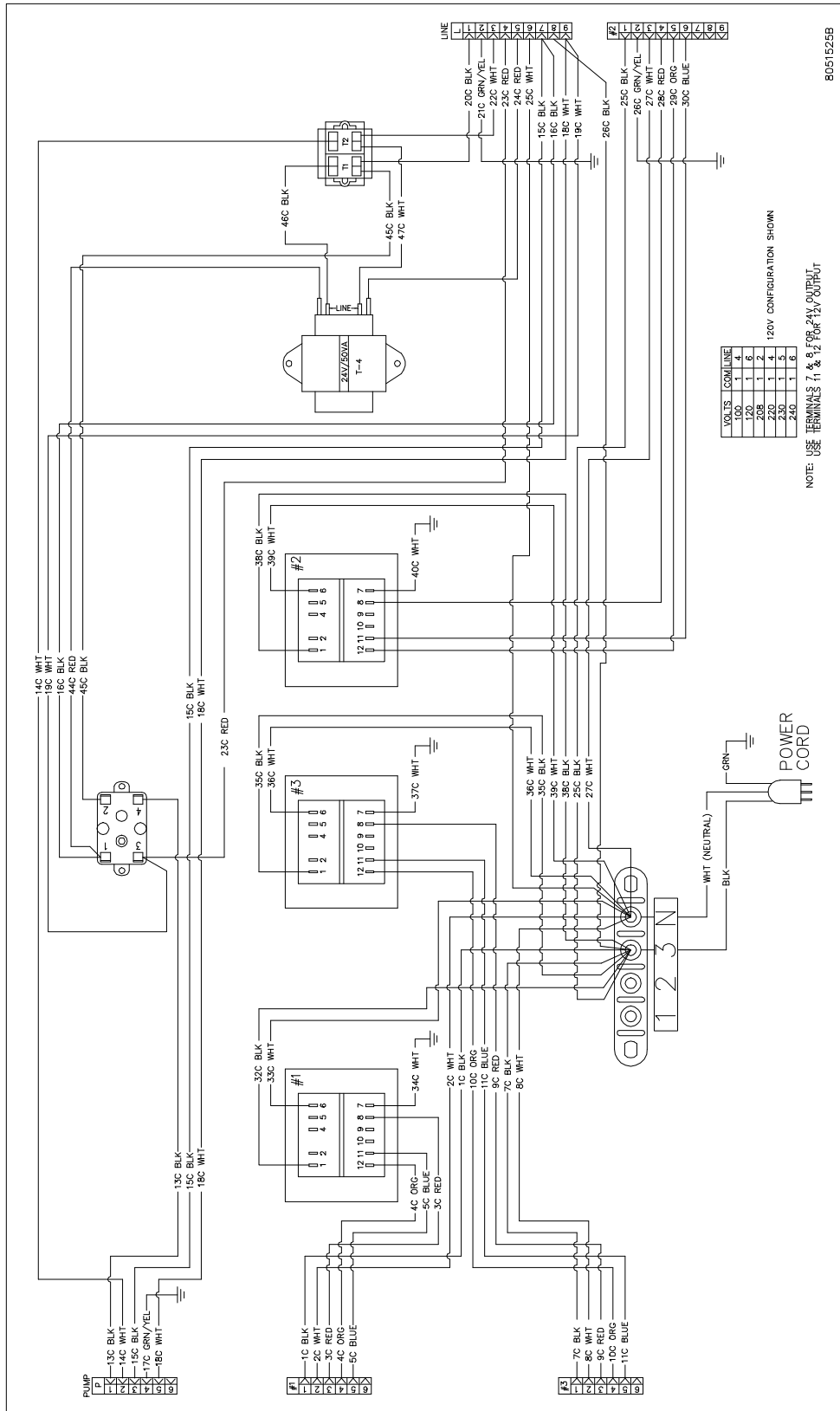

1.11.9 Modular Basket Lift -100V/120V - Prior to Jan. 2023

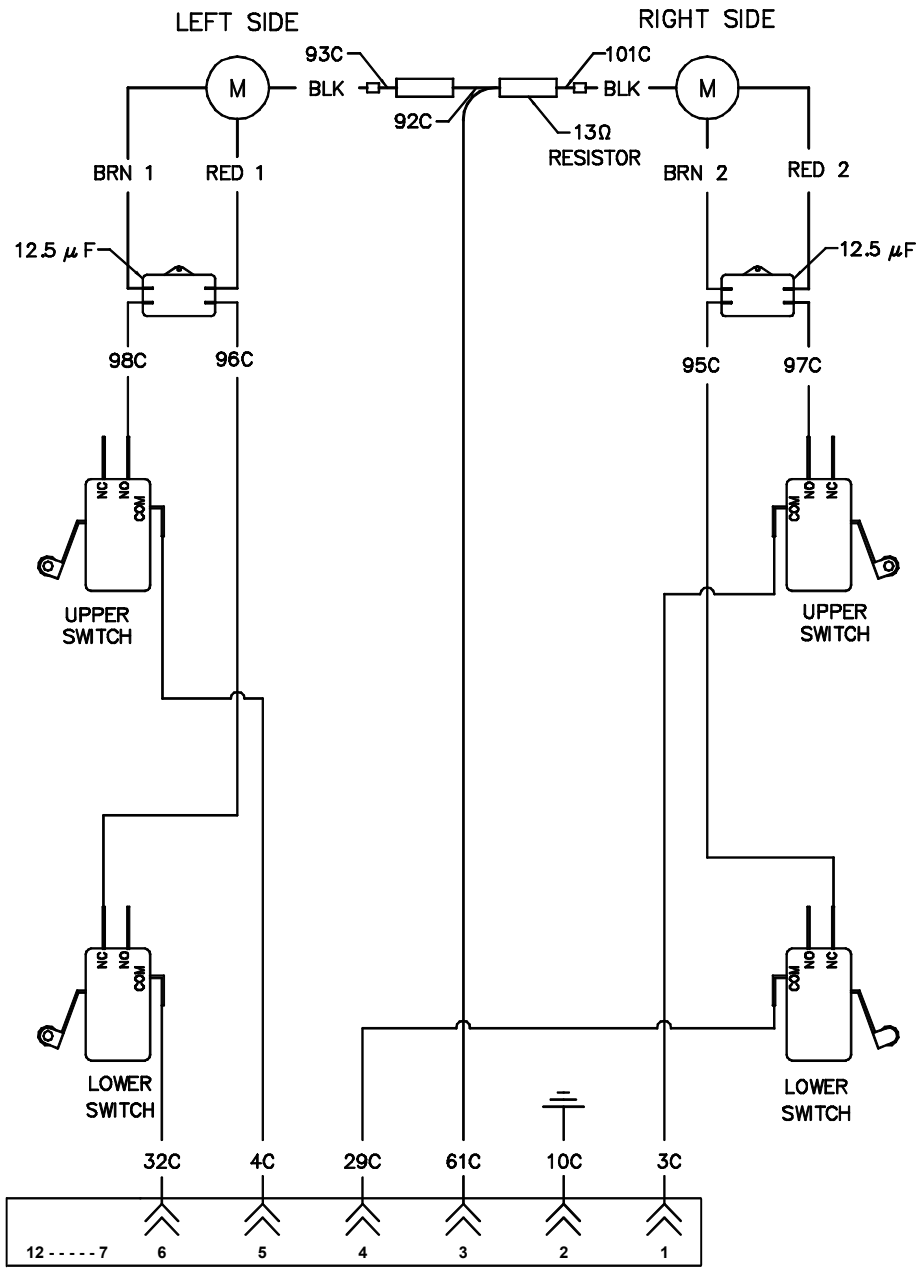

REFERENCES TO LEFT & RIGHT ARE
FROM THE REAR OF THE FRYER

8050518E

1.11.10 Modular Basket Lift - 208/250V- After Feb 2002

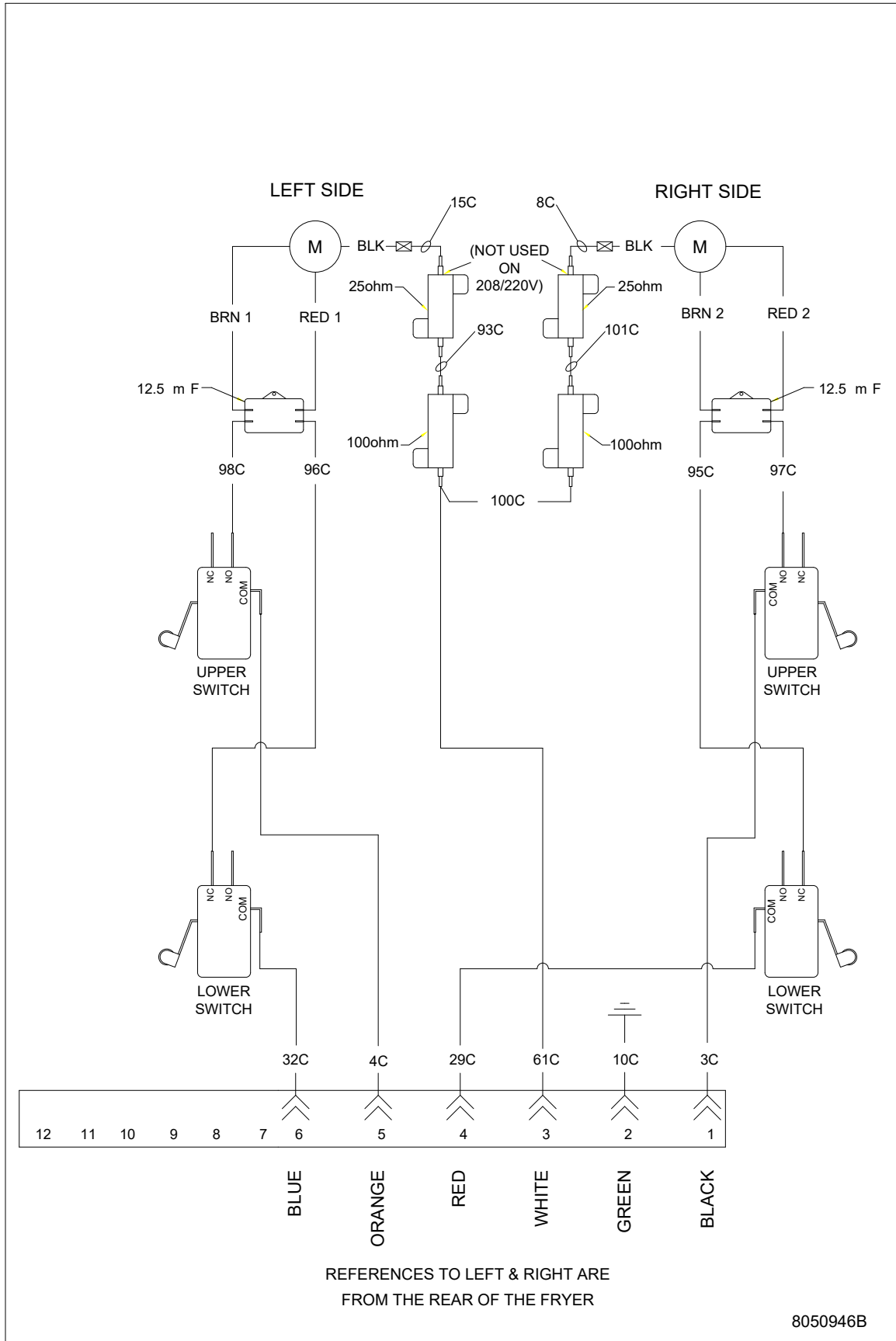

1.11.11 Modular Basket Lift H55 / H155 - 120V - After Jan. 2023

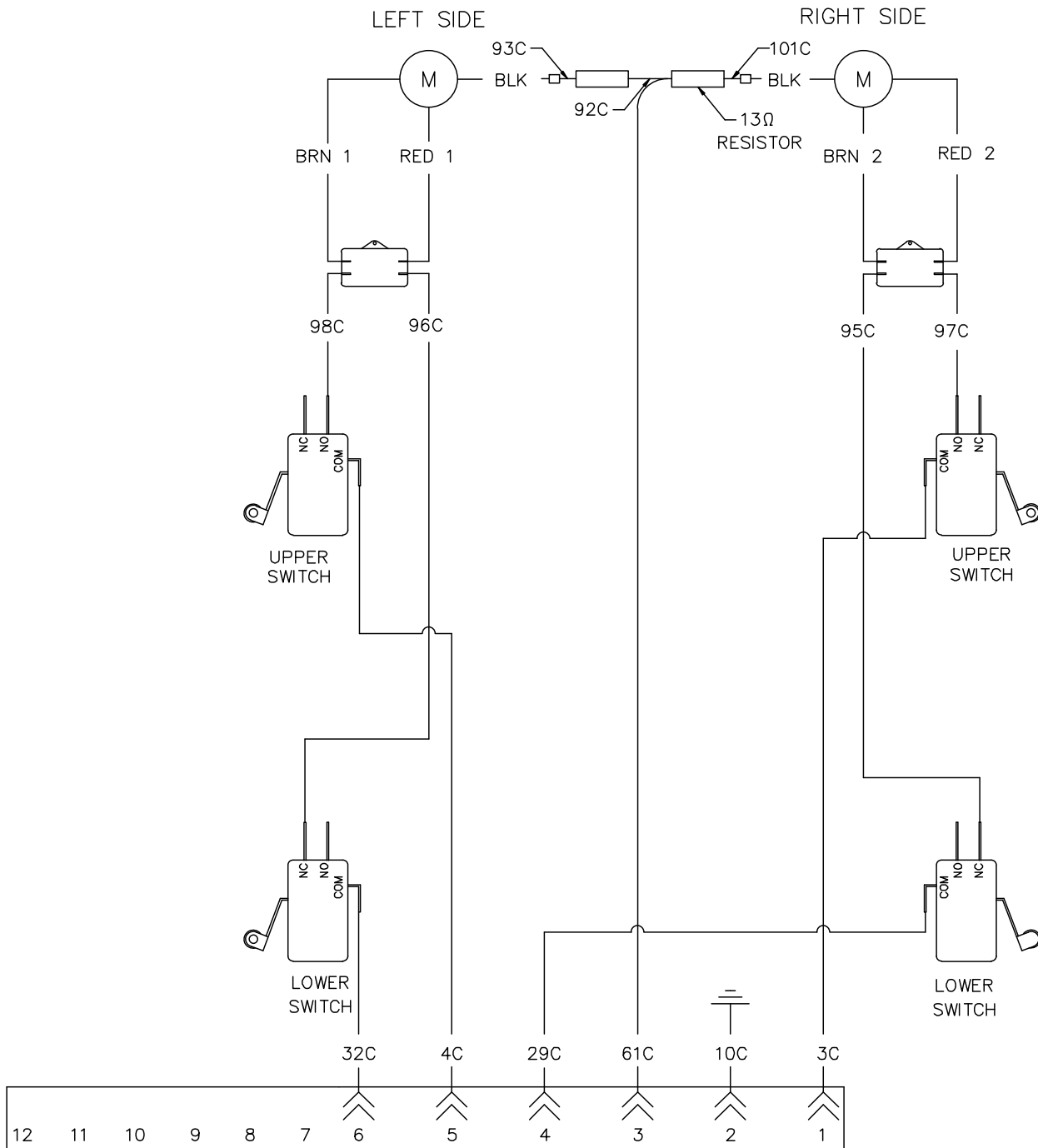

REFERENCES TO LEFT & RIGHT ARE
FROM THE REAR OF THE FRYER

8050518G

1.11.12 Modular Basket Lift H55 / H155 - 208V-250V - After Jan. 2013

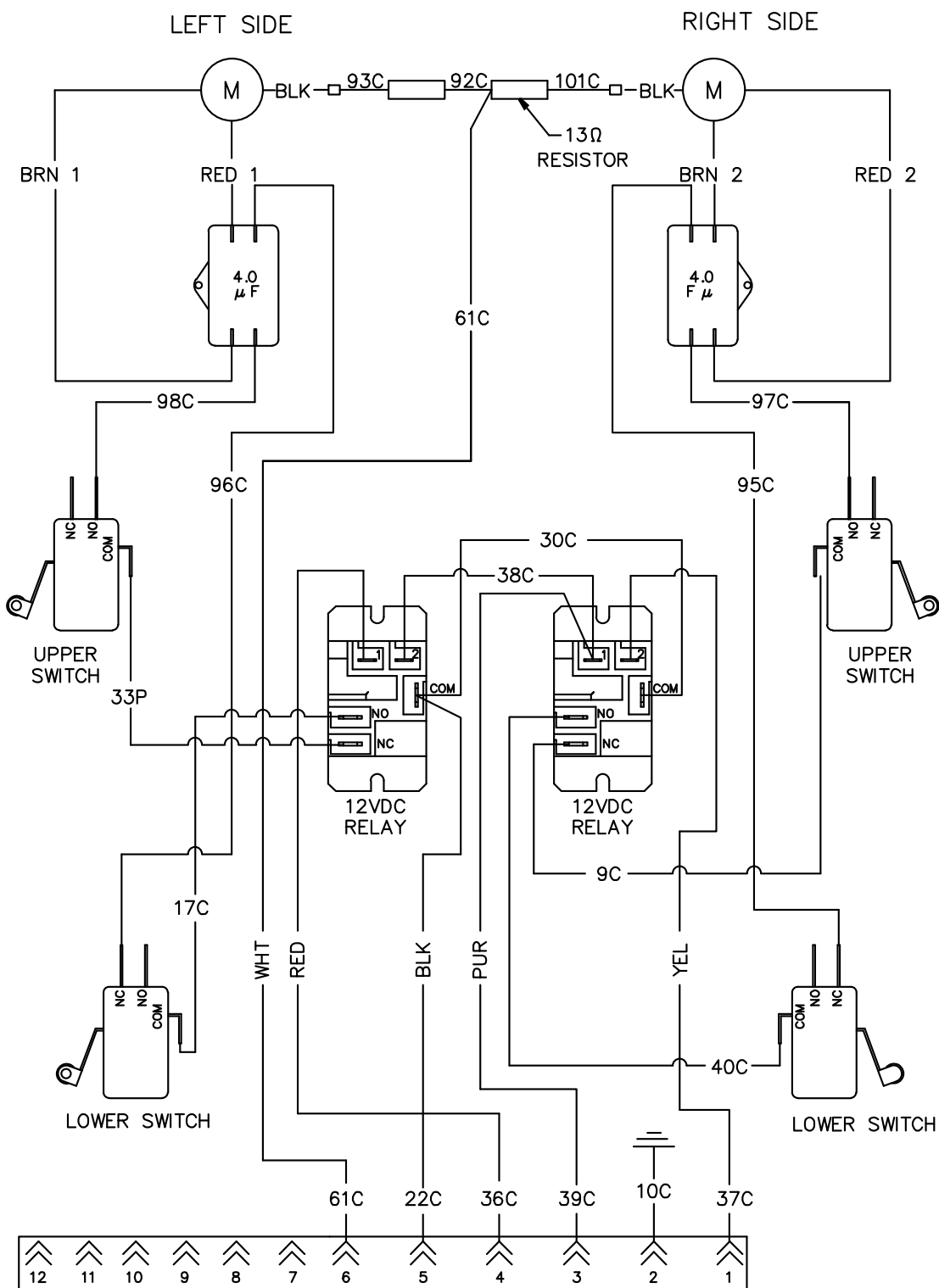

REFERENCES TO LEFT & RIGHT ARE FROM THE REAR OF THE FRYER

8051964B

1.11.13 Wiring Diagrams – Oil Return/Disposal

Oil Return/Wand Wiring (Japan)

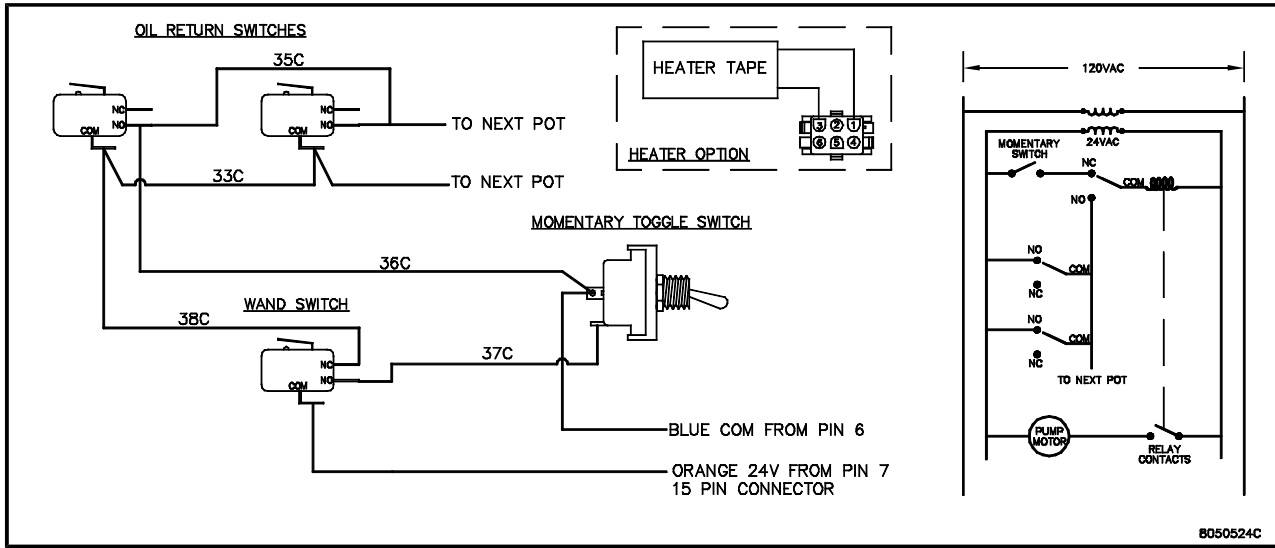

Oil Return/Disposal Wiring (Sonic)

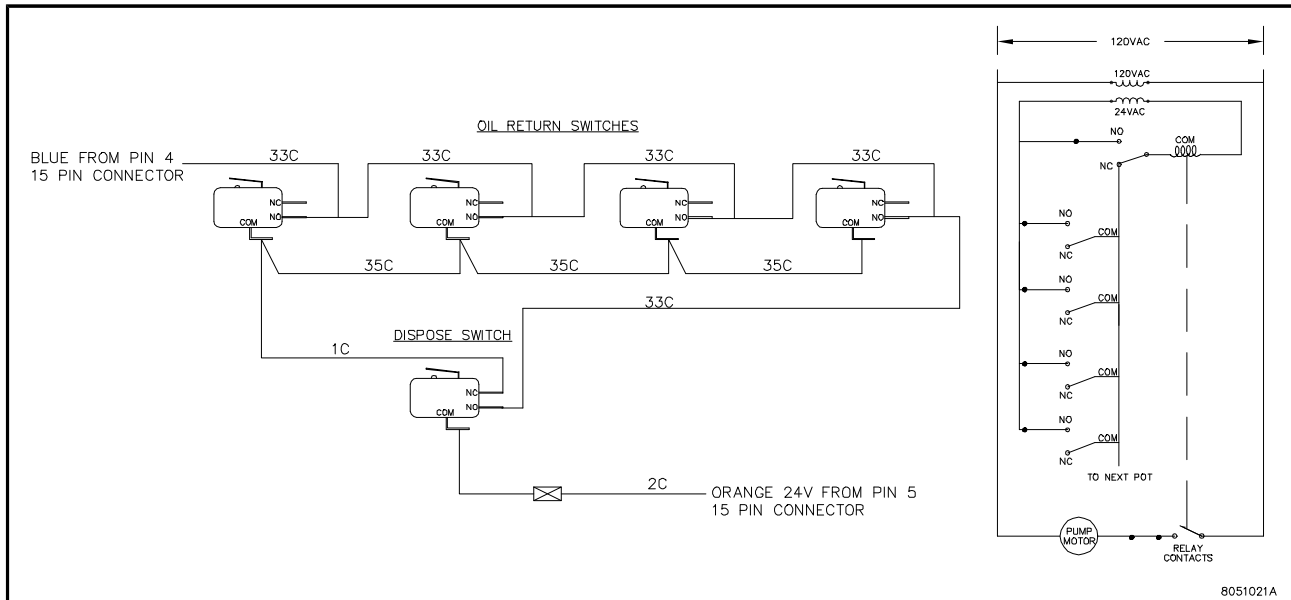

PRO H50/55-SERIES GAS FRYERS

CHAPTER 2: PARTS LIST

2.1 Accessories

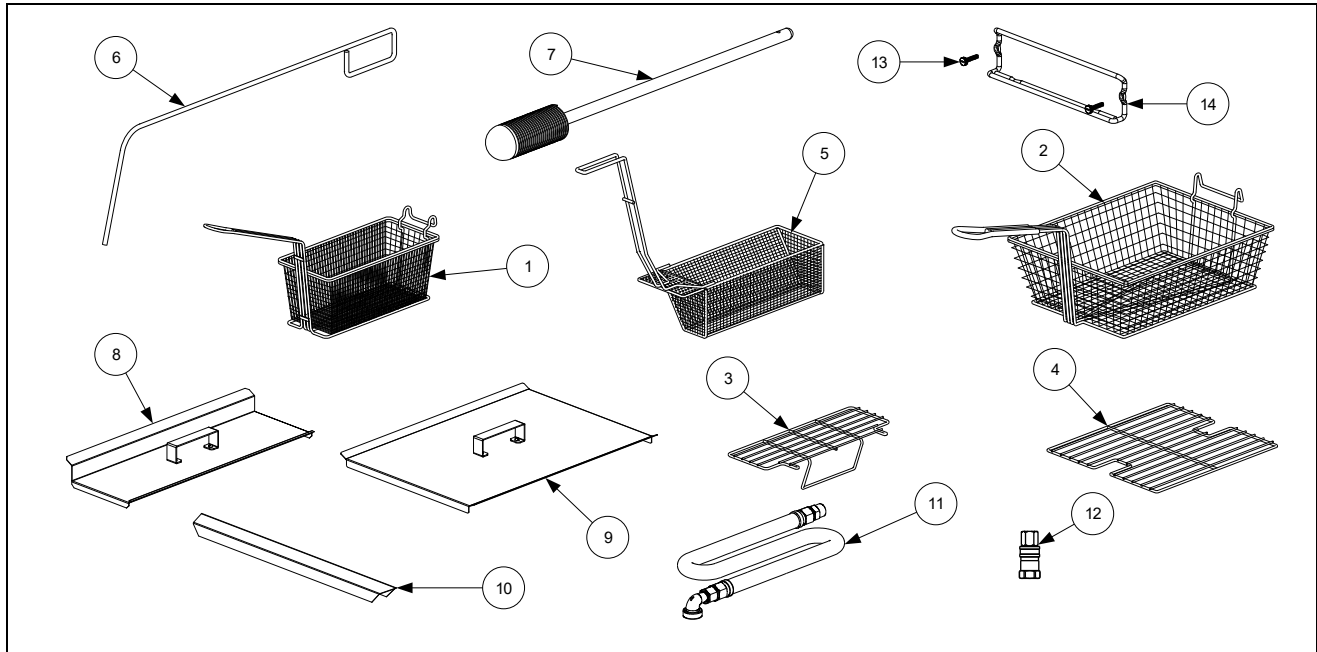

ITEM	PART #	COMPONENT
1	8030271	Basket, Twin
2	8030099	Basket, Full <i>(cannot be used with basket lifts)</i>
3	8030133	Basket Support Rack, Dual Vat
4	8030132	Basket Support Rack, Full Vat
*	8030136	Basket Support Screen, Full Vat <i>(screen w/handle used in place of Item 4)</i>
5		Sediment Screens
	8030103	Full Vat
	8030107	Dual Vat, Left
	8030108	Dual Vat, Right
6	8030197	Cleanout Rod, 27-inch (Fryer's Friend)
7	8030209	Brush, Frypot
8	8063232	Cover, Frypot, Dual Vat
9	8065518	Cover, Frypot, Full Vat
*	8260993SP	Handle Kit, Frypot Cover <i>(includes handle and screws)</i>
10	9107443	Top Connecting Strip, Frypot
*	8231885	Top Connecting Strip, Frypot, Burger King
*	9106650	Channel, Top Connecting Strip
*	9105126	Channel, Top Connecting Strip, Burger King
11		Gas Line, 1-Inch Dormont Flexible
	8100088	36-Inch 1-Inch Dormont Flexible
	8100085	48-Inch 1-Inch Dormont Flexible
12	130001257	Quick-Disconnect Fitting, 1-Inch Male and Female
13	8090171	Thumbscrew, 1/4-20 X 1 3/8-inch Basket Hanger <i>(for spacer use 8090921)</i>
14	8102793	Hanger, Basket
*	8030170	Filter Paper - 100 Sheets
*	8030002	Powder, Filter - 80 Packages
*		Food Warmer (see 8196330, <i>Food Warmer IOSP Manual</i>)

* Not illustrated.

2.2 Basket Lift Assemblies and Component Parts

2.2.1 Basket Lift Assemblies and Component Parts – From June 1997 to April 2012

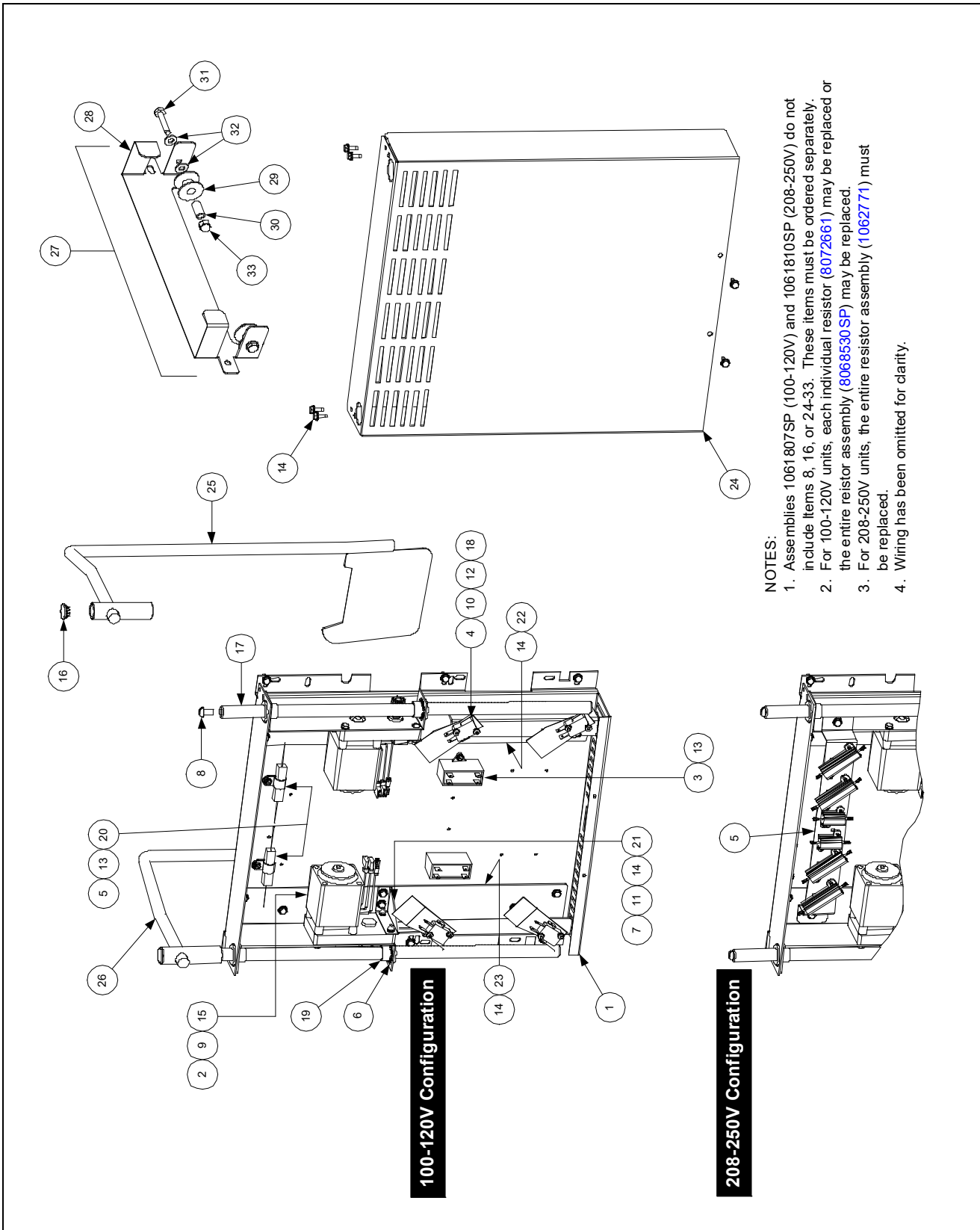

2.2.1 Basket Lift Assemblies and Component Parts – From June 1997 to April 2012

ITEM	PART #	COMPONENT
1	2002942	Mount, Modular Basket Lift
2	8065964SP	Motor Assembly, Modular Basket Lift
3	8072133	Capacitor, 12.5 μ Farad, 250VAC Motor Run
4	8072572	Microswitch
5		Resistor Assembly
	8068530SP	100-120V Modular Basket Lift (<i>see Note 2 in illustration</i>)
	1062771	208-250V Modular Basket Lift
6	8090082	Ring, Truarc Retaining
7	8261361	Screw, 2-32 X 1-inch Slotted Truss Head (pkg. of 25)
8	8090127	Screw, 1/4-20 X 1/2-inch Slotted Round Head
9	8090186	Lock Washer w/External Teeth, #8
10	8261366	Nut, 4-40 Hex Keps (pkg. of 25)
11	8090247	Nut, 2-32 Hex Keps
12	8261359	Screw, 4-40 X 3/4-inch Slotted Round Head (pkg. of 25)
13	8261371	Screw, #8 X 1/2-inch Hex Head Drill Point (pkg. of 25)
14	8261374	Screw, #10 X 1/2-inch Hex Head (pkg. of 25)
15	8090503	Screw, 2-32 X 1/2-inch Hex Head
16	8100172	Plug, 5/8-inch Stainless Steel Hole
17	8101012	Rod, Modular Basket Lift
18	8120442	Insulation, Microswitch
19	8130035	Bushing, Bronze, .640" ID
20	8160033	Tie Wrap, Screw Mount
21	9005529	Gusset, Modular Basket Lift Motor
22	9018499	Chassis, Modular Basket Lift, Left
23	9028499	Chassis, Modular Basket Lift, Right
24	9104776	Cover, S/S Modular Basket Lift (<i>for CRS cover use 9004776</i>)
25	82306931	Rod Assembly, Left Basket Lift
26	82306932	Rod Assembly, Right Basket Lift
27	8069257SP	Roller Assembly, Basket Lift
28	9108284	Bracket, Basket Lift Roller
29	8100194	Roller, Basket Lift
30	8100374	Spacer, Basket Lift Roller
31	8090508	Bolt, 1/4-20 X 1 1/4-inch
32	8090190	Washer, 1/4-inch Flat
33	8090047	Nut, 1/4-20 Cap
*	8070159	Connector, 12-Pin Panel Mount
*	8073695	Harness, Modular Basket Lift to 15-pin Plug
*	8072000	Harness, 15-pin Plug to Component Box
		Wire Assemblies
*	1061822SP	For 100-120V Modular Basket Lift
*	1061804SP	For 208-250V Modular Basket Lift
		Basket Lift Assemblies (<i>see Note 1 in illustration</i>)
*	1061807SP	100-120V w/o Relay
*	1061810SP	208-250V w/o Relay

* Not illustrated.

2.2.2 Basket Lift Assemblies and Component Parts H55/H155 – 120V - After April 2012 (Modular)

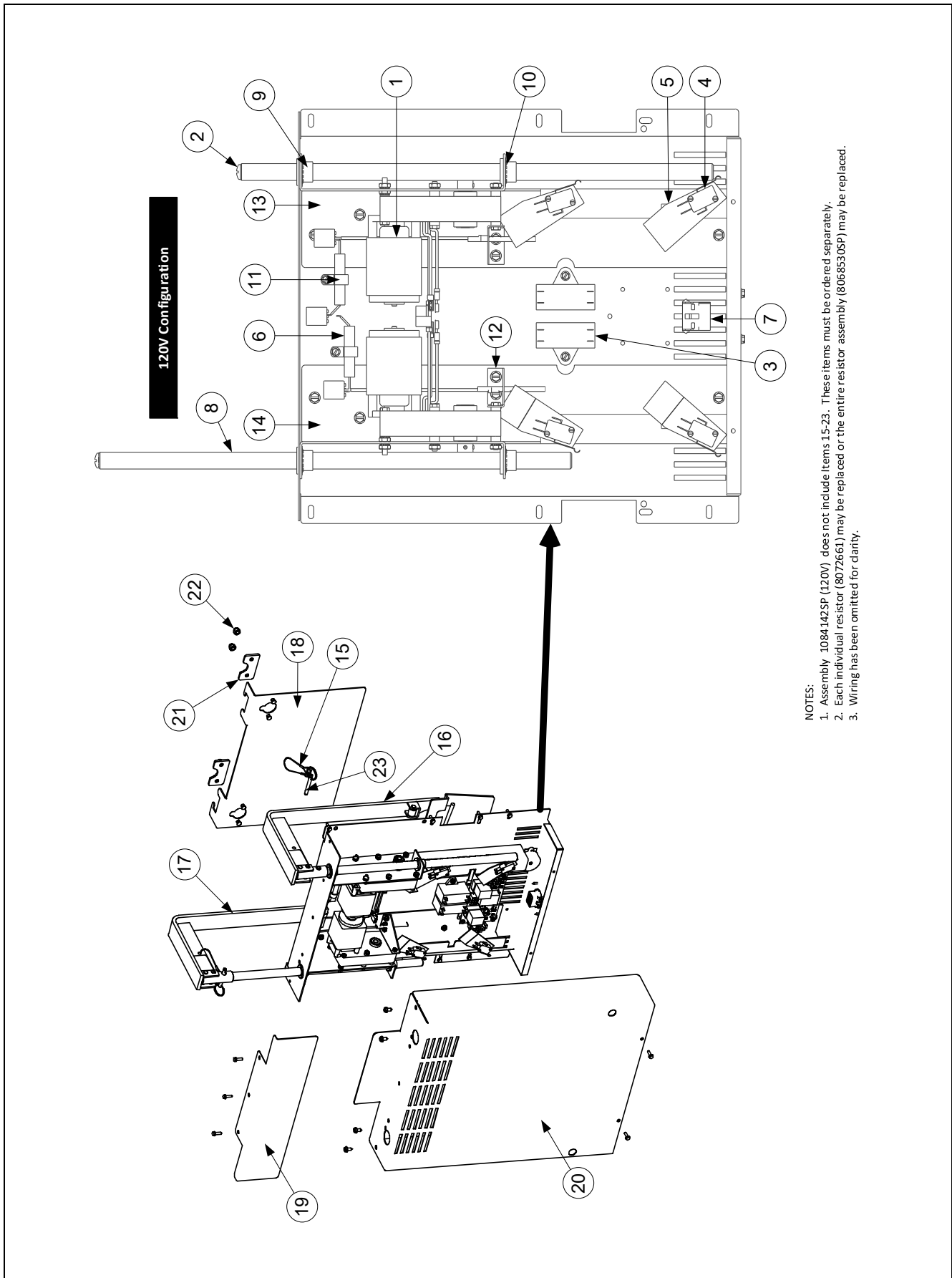

2.2.2 Basket Lift Assemblies and Component Parts H55/H155 – 120V - After April 2012 (Modular)

ITEM	PART #	COMPONENT
		Basket Lift Assemblies (see <i>Note 1</i> in illustration)
A	1084142SP	Basket Lift Assy, 120VAC (Items 1-14)
1	1084181SP	Motor Assy, 120VAC Modular Basket Lift
2	8090129	Screw, 1/4-20 X 5/8 Slotted Round Head
3	8072513	Capacitor, Motor Run 12.5 MFD 330VAC
4	8072572	Microswitch
5	8120442	Insulation, Microswitch Box
6	8068530SP	Resistor Assembly (see <i>Note 2</i> in illustration)
7	1061804	Wire Assembly, 240V Modular B/L
8	8101012	Rod, Modular BL
9	8130035	Bushing, Bronze
10	8090082	Ring, Bushing Retainer 3/4 Truarc
11	8090810	Clamp, Nylon
12	2209678	Gusset, Reversing Basket Lift Motor
13	2229624	Chassis, H55 Modular Basket Lift
14	2219624	Chassis, H55 Modular Basket Lift
15	8104854	Lanyard, w/Ring
16	8238458	Arm, Left (Illustration May Slightly Differ) (P/N 8239442 for H155)
17	8238459	Arm, Right (Illustration May Slightly Differ) (P/N 8239443 for H155)
18	2309950	Guide, B/L Arm (Illustration May Slightly Differ)
19	2401693	Shield, Rear Modular B/L Cover
20	2401707	Cover, Modular B/L (Illustration May Slightly Differ)
21	2601474	Cover, Basket Hanger Rivet B/L
22	8090047	Nut, Cap 1/4" -20
23	8104852	Pin, 1/4" X 1-5/16" Quick Release

2.2.3 Basket Lift Assembly and Component Parts H55/H155 – 208V-250V- After April 2022 (Modular)

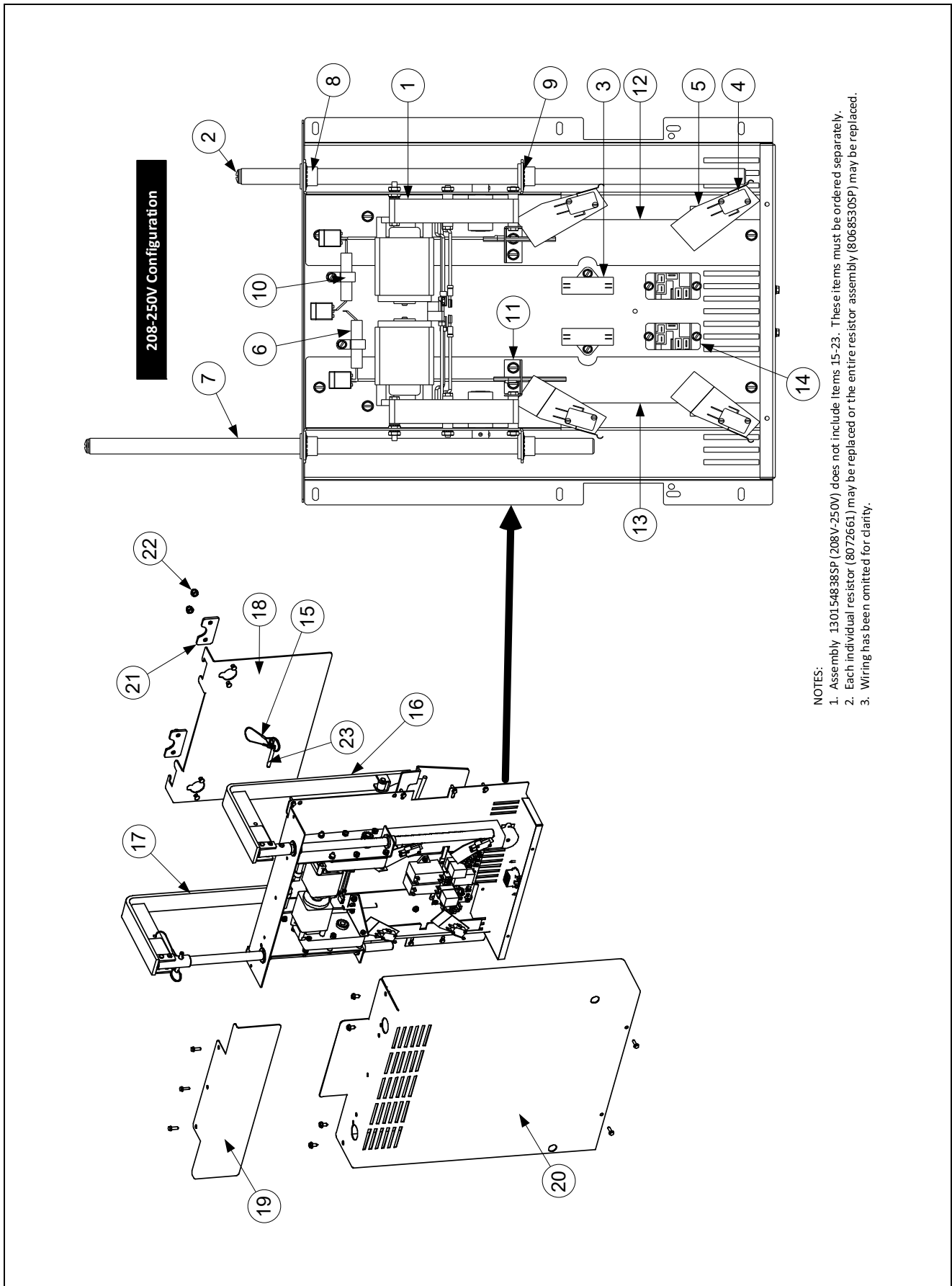

2.2.3 Basket Lift Assembly and Component Parts H55/H155 – 208V-250V- After April 2022 (Modular)

ITEM	PART #	COMPONENT
		Basket Lift Assemblies (see <i>Note 1</i> in illustration)
A	130154838SP	Basket Lift Assy, 208-250VAC (Items 1-14)
1	1085031SP	Rev Motor Assy, Basket Lift w/Gear 208V-250V
2	8090129	Screw, 1/4-20 X 5/8 Slotted Round Head
3	8076253	Capacitor, Motor Run 4.0 MFD 440VAC
4	8072572	Microswitch
5	8120442	Insulation, Microswitch Box
6	8068530SP	Resistor Assembly (see <i>Note 2</i> in illustration)
7	8101012	Rod, Modular BL
8	8130035	Bushing, Bronze
9	8090082	Ring, Bushing Retainer ¾ Truarc
10	8090810	Clamp, Nylon
11	2209678	Gusset, Reversing Basket Lift Motor
12	2229624	Chassis, H55 Modular Basket Lift
13	2219624	Chassis, H55 Modular Basket Lift
14	8071683	Relay, 12VDC
15	8104854	Lanyard, w/Ring
16	8238458	Arm, Left (Illustration May Slightly Differ) (P/N 8239442 for H155)
17	8238459	Arm, Right (Illustration May Slightly Differ) (P/N 8239443 for H155)
18	1087760	Guide, B/L Arm (Illustration May Slightly Differ)
19	2401693	Shield, Rear Modular B/L Cover
20	2601709	Cover, Modular B/L (Illustration May Slightly Differ)
21	2601474	Cover, Basket Hanger Rivet B/L
22	8090047	Nut, Cap ¼" -20
23	8104852	Pin, ¼" X 1-5/16" Quick Release

2.3 Cabinetry

2.3.1 Backs, Doors, Flue Caps, Sides, and Top Caps

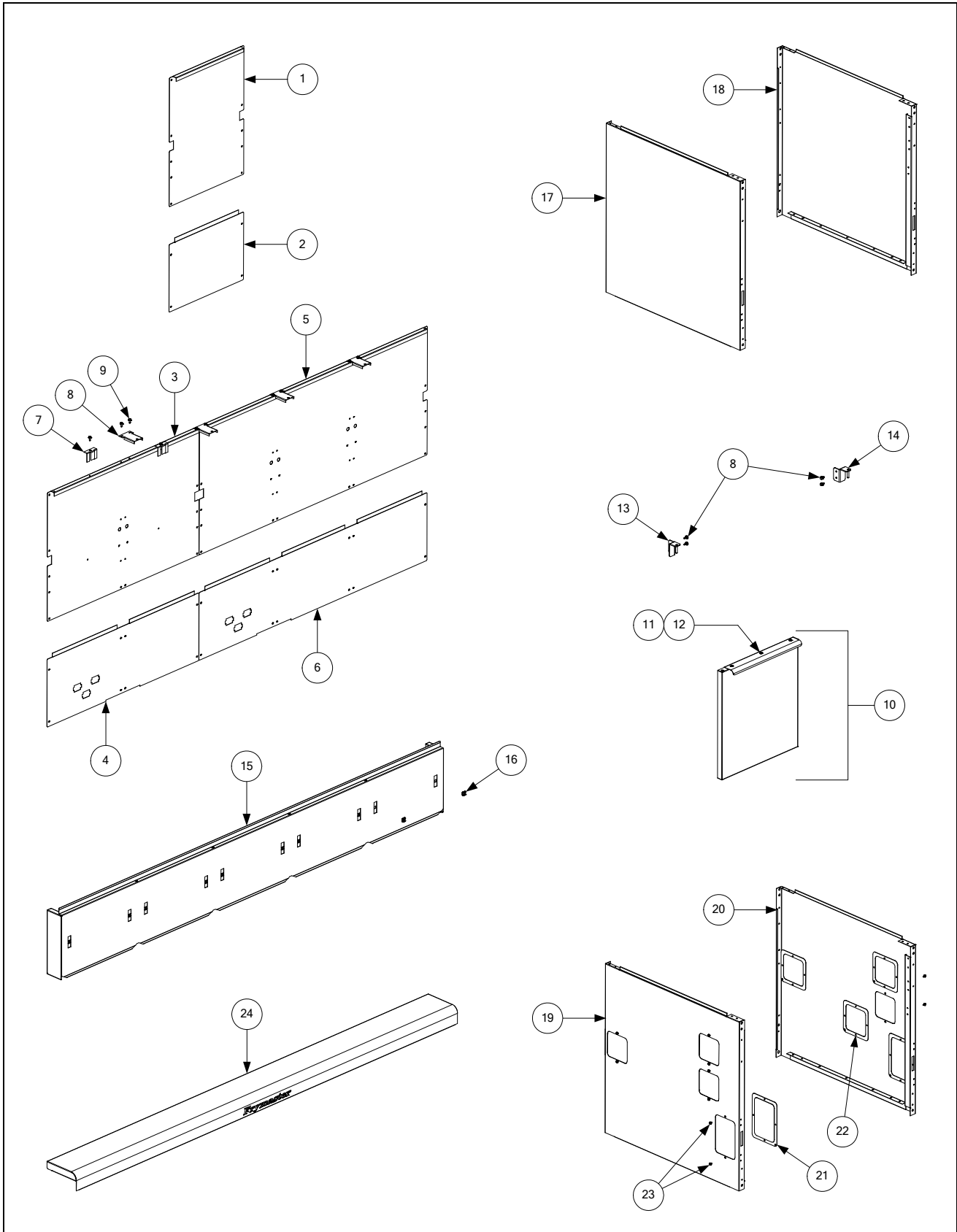

ITEM	PART #	COMPONENT
1		Back, Single Upper
	2106581	Stainless Steel
	2006581	Cold Rolled Steel
2		Back, Single Lower
	2106580	Stainless Steel
	2006580	Cold Rolled Steel
3		Back, Double Upper <i>(for 2-, 4-, and 5-station fryers – does not include Items 7-9)</i>
	2106542	Stainless Steel
	2006540	Cold Rolled Steel
4		Back, Double Lower <i>(for 2-, 4-, and 5-station fryers – does not include Items 7-9)</i>
	2106541	Stainless Steel
	2006539	Cold Rolled Steel
5		Back, Triple Upper <i>(for 3- and 5-station fryers – does not include Items 7-9)</i>
	2106545	Stainless Steel
	2006547	Cold Rolled Steel
6		Back, Triple Lower <i>(for 3- and 5-station fryers – does not include Items 7-9)</i>
	2106544	Stainless Steel
	2006546	Cold Rolled Steel
7	2006419	Clip, Flue Support
8	2005865	Support, Flue Cap
9	8261374	Screw, #10 X 1/2-inch Hex Washer Head (pkg. of 25)
10	1063966	Door, Left or Right <i>(Left shown – move handle to bottom for Right)</i>
11	8090266	Screw, #10 X 1/2-inch Phillips Truss Head
12	2106820	Handle, Door
13	8234729	Hinge, Left Door Upper
14	8234730	Hinge, Right Door Upper
15		Flue Cap <i>(Cap for 5-station fryer shown – does not include Item 16)</i>
	2105549	Single Fryer <i>(use 8234367 for BK w/Buttons)</i>
	1063579	2-Station Fryer <i>(use 1063545 for BK w/Buttons)</i>
	1063537	3-Station Fryer <i>(use 1063546 for BK w/Buttons)</i>
	1063535	4-Station Fryer <i>(use 1063547 for BK w/Buttons)</i>
	1063536	5-Station Fryer <i>(use 1063548 for BK w/Buttons)</i>
16	8261351	Nut Retainer, 1/4-20 (pkg. of 10 – receives basket hanger thumbscrew)
17		Side, Left Standard Cabinet
	2116510	Stainless Steel
	2016633	Enameled Steel
18		Side, Right Standard Cabinet
	2126510	Stainless Steel
	2026633	Enameled Steel
19		Side, Left Filter Ready Cabinet
	2116660	Stainless Steel
	2016660	Enameled Steel
20		Side, Right Filter Ready Cabinet
	2126660	Stainless Steel
	2026660	Enameled Steel
21	9100890	Cover, 5-inch X 7-inch Access
22	9100889	Cover, 5-inch X 5-inch Access
23	8090359	Screw, #8 X 1/4-inch Hex Washer Head
24		Top Cap <i>(Cap 5-station fryer shown)</i>
	8241310	Single Fryer <i>(use 8241689 for fryers mfd. After 3.15.06)</i>
	8241357	2-Station Fryer <i>(use 8241690 for fryers mfd. After 3.15.06)</i>
	8234702	3-Station Fryer <i>(use 8235733 for fryers mfd. After 3.15.06)</i>
	8234704	4-Station Fryer <i>(use 8245734 for fryers mfd. After 3.15.06)</i>
	8234706	5-Station Fryer <i>(use 8245735 for fryers mfd. After 3.15.06)</i>

2.3.2 Filter Cabinet Bases, Casters, Framing, and Related Components

The 5-station cabinet illustrated is typical of all Pro Series (H50/55) gas filter cabinets. All base and framing components used in Pro Series (H50/55) gas filter cabinets are identified, but not all components are used in every configuration.

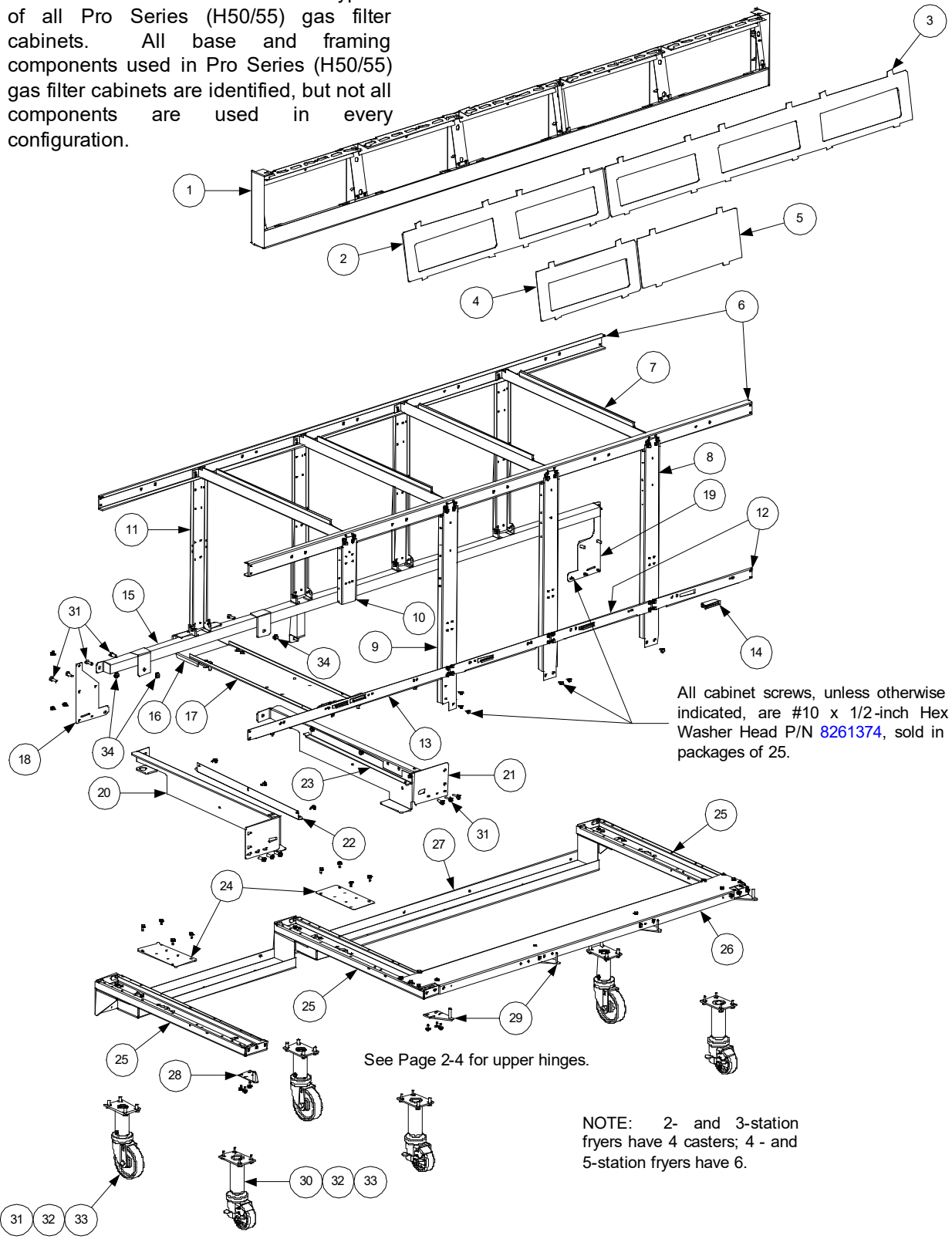

ITEM	PART #	COMPONENT
1		Frame, Control Panel
	1063902SP	Two-Station, Standard <i>(use 1065221SP mfd. After 3.15.06)(use 1066082 for fallback)</i>
	1063903SP	Three-Station, Standard <i>(use 1065018SP mfd. After 3.15.06)(use 1066086 for fallback)</i>
	1063904SP	Four-Station, Standard <i>(use 1065019 mfd. After 3.15.06) (use 1066087 for fallback)</i>
	1063905	Five-Station, Standard <i>(use 1065020 mfd. After 3.15.06) (use 1066089 for fallback)</i>
2	2105819	Bezel, Two-Controller
3	2106698	Bezel, Three-Controller
4	2105046	Bezel, One-Controller
5	2105623	Bezel, Blank
6		Brace, Cabinet Top
	9007730	Two-Station
	9009430	Three-Station
	9009318	Four-Station
	2005474	Five-Station
7	2005478	Divider, Cabinet
8	2006614	Post, Cabinet Front
9	2006031	Post, Filter Door
10	2002235	Bracket, Component Box Support
11	2006550	Post, Cabinet Rear
12	2001953	Brace, Front Cabinet
13	2006507	Support, Cross Cabinet
14	8101105	Magnet, Door
15		Manifold, Rear
	8233223	Two-Station
	8234691	Three-Station
	8234693	Four-Station
	8234694	Five-Station
16	2002213	Bracket, Rear Bridge Support
17	2000913	Bridge, Filter Pump
18	2006326	Gusset, Left Rear Corner
19	2007031	Gusset, Right Rear Corner
20	2016508	Support, Left Filter Rail
21	2026508	Support, Right Filter Rail
22	8234651	Slide, Filter Pan Lid Left
23	8234652	Slide, Filter Pan Lid Right
24	2002102	Brace, Side Channel
25	8234653	Channel, Side Base
26		Channel, Front Base <i>(not used in two-station fryers)</i>
	2006609	Three-Station
	2006610	Four-Station
	2005473	Five-Station
27		Channel, Rear Base
	8234510	Two-Station
	8234630	Three-Station
	8234629	Four-Station
	8234628	Five-Station
28	8234732	Hinge, Lower Left
29	8234733	Hinge, Lower Right <i>(attach to hinge bracket 2005478 in 4- & 5-station fryers)</i>
30	8100944	Caster w/Brake, 8 1/2 to 10-inch Adjustable <i>(3-inch wheel)</i>
31	8100327	Caster w/o Brake, 8 1/2 to 10-inch Adjustable <i>(4-inch wheel)</i>
32	8090953	Bolt, 1/4-20 x 3/4-inch Hex Head
33	8090191	Washer, 1/4-inch Lock
34	8090417	Nut, 1/4-20 Flange
*	8101494	Caster w/o Brake, 4-inch Swivel
*	8100326	Caster w/Brake, 4-inch Adjustable

* Not illustrated.

2.3.3 Non-Filter Cabinet Bases, Casters, Framing, and Related Components

The 5-station cabinet illustrated is typical of all Pro Series (H50/55) gas non-filter cabinets. All base and framing components used in Pro Series (H50/55) gas non-filter cabinets are identified, but not all components are used in every configuration.

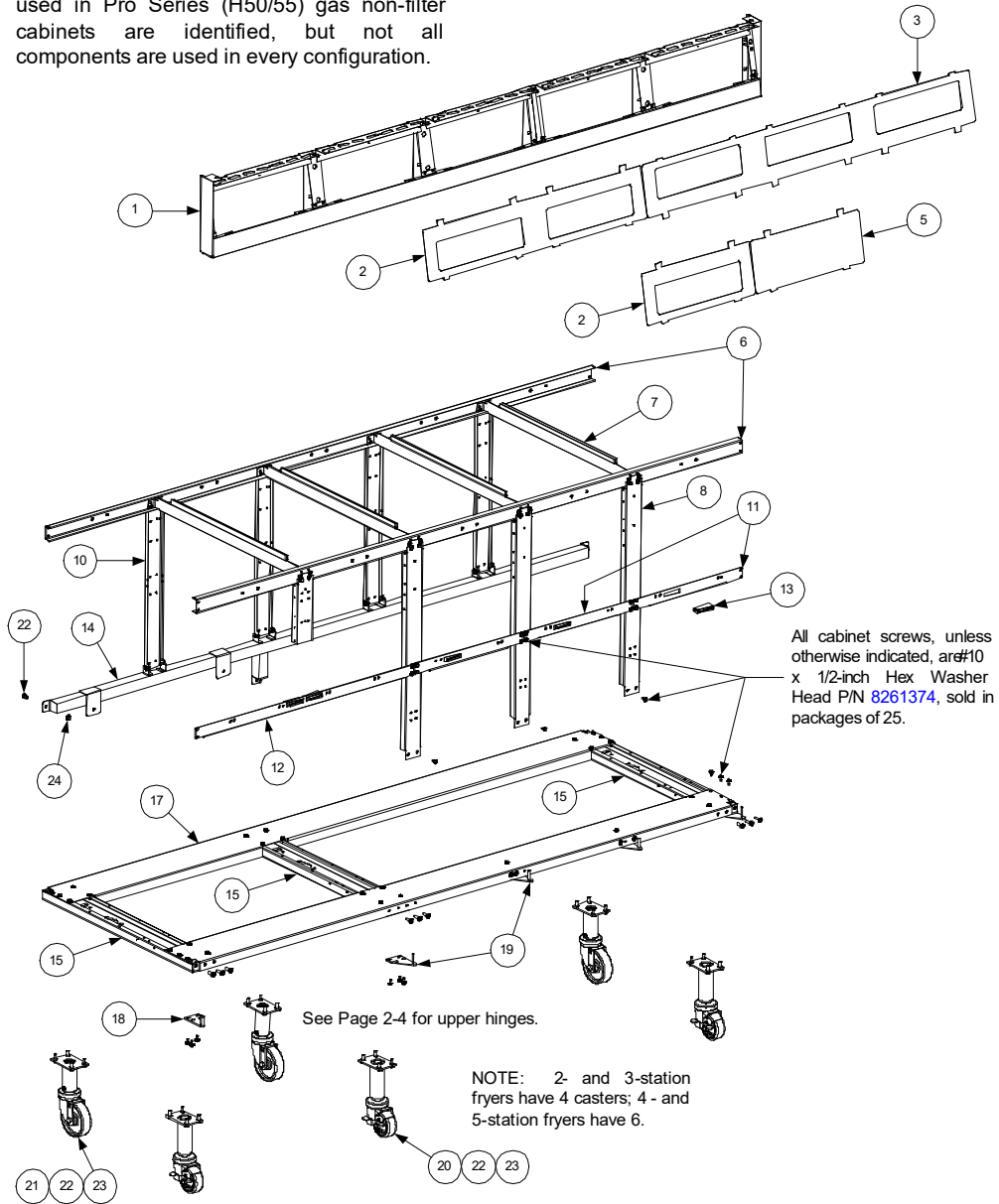

ITEM	PART #	COMPONENT
1		Frame, Control Panel
	8064732	Single-Station, Standard <i>(use 1065016 mfd. After 3.15.06) (use 1066079 for fallback)</i>
	1063902SP	Two-Station, Standard <i>(use 1065221SP mfd. After 3.15.06)(use 1066082 for fallback)</i>
	1063903SP	Three-Station, Standard <i>(use 10655018SP mfd. After 3.15.06)(use 1066086 for fallback)</i>
	1063904SP	Four-Station, Standard <i>(use 1065019 mfd. After 3.15.06)(use 1066087 for fallback)</i>
	1063905	Five-Station, Standard <i>(use 1065020 mfd. After 3.15.06)(use 1066089 for fallback)</i>
2	2105819	Bezel, Two-Controller
3	2106698	Bezel, Three-Controller
4	210046	Bezel, One-Controller
5	2105623	Bezel, Blank
6		Brace, Cabinet Top
	2005498	Single Fryer
	9007730	Two-Station
	9009430	Three-Station
	9009318	Four-Station
	2005474	Five-Station
7	2005478	Divider, Cabinet
8	2006614	Post, Cabinet Front
9	2002235	Bracket, Component Box Support
10	2006550	Post, Cabinet Rear
11	2001953	Brace, Front Cabinet
12	2006507	Support, Cross Cabinet
13	8101105	Magnet, Door
14		Manifold, Rear <i>(not present in single fryers)</i>
	8233223	Two-Station
	8234691	Three-Station
	8234693	Four-Station
	8234694	Five-Station
15	8234653	Channel, Side Base
16		Channel, Front Base
	2006616	Single Fryer <i>(also used as rear base channel in single-station fryers)</i>
	2006623	Two-Station <i>(also used as rear base channel in single-station fryers)</i>
	2006624	Three-Station <i>(also used as rear base channel in single-station fryers)</i>
	2006625	Four-Station
	2006627	Five-Station
17		Channel, Rear Base
	2006626	Four-Station
	2006628	Five-Station
18	8234732	Hinge, Lower Left
19	8234733	Hinge, Lower Right <i>(attach to bracket 2005478 in 3-, 4-, & 5-station fryers)</i>
20	8100944	Caster w/Brake, 8 1/2 to 10-inch Adjustable <i>(3-inch wheel)</i>
21	8100327	Caster w/o Brake, 8 1/2 to 10-inch Adjustable <i>(4-inch wheel)</i>
22	8090953	Bolt, 1/4-20 x 3/4-inch Hex Head
23	8090191	Washer, 1/4-inch Lock
24	8090417	Nut, 1/4-20 Flange

2.4 Controllers

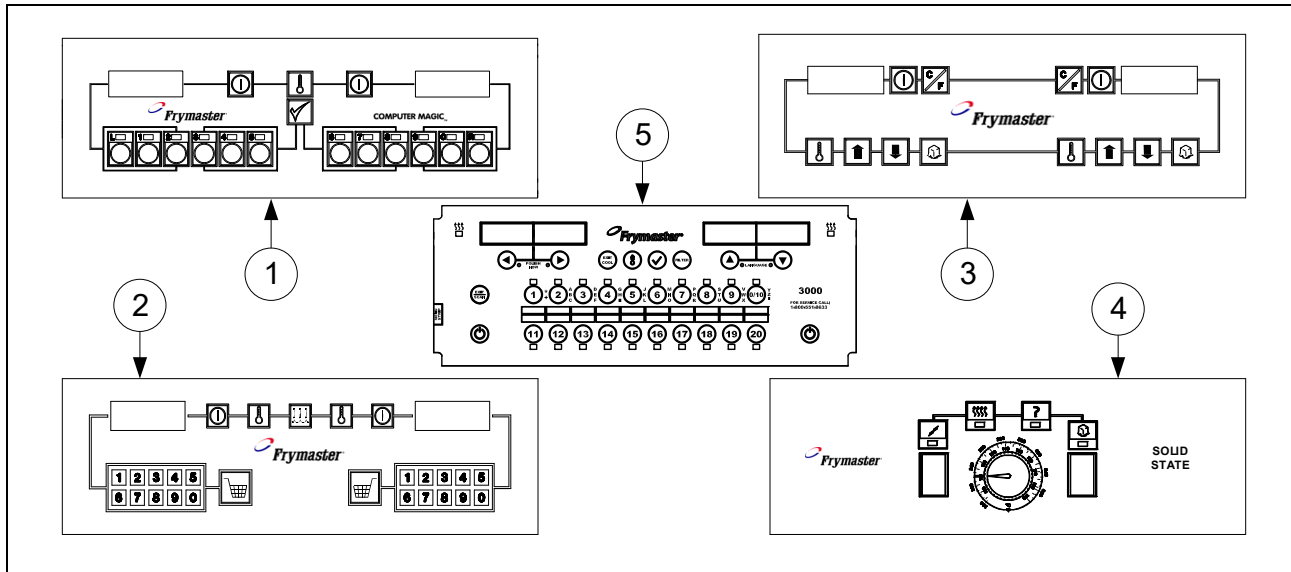

ITEM	*Standard PART #	*Euro-Look PART #	COMPONENT
1			Computer Magic III.5 Dual-vat (Domestic U.S.) Dual-vat (CE) (<i>use 1063450 for 8-second MC Non-CE export units</i>) Full-vat (Domestic U.S.) Full-vat (CE) (<i>use 1063449 for 8-second MC Non-CE export units</i>)
2			Basket Lift Timer Dual-vat (Domestic U.S.) Dual-vat (CE) (<i>use 1063497 for 8-second MC Non-CE export units</i>) Full-vat (Domestic U.S.) Full-vat (CE) (<i>use 1063498 for 8-second MC Non-CE export units</i>)
3			Digital Controller Dual-vat (Domestic U.S.) Dual-vat (CE) (<i>use 1063499 for 8-second MC Non-CE export units</i>) Full-vat (Domestic U.S.) Full-vat (CE) (<i>use 1063500 for 8-second MC Non-CE export units</i>)
4			Solid State (Analog) Controller (<i>controller knob is 8100387</i>) Dual-vat (Domestic U.S.) (<i>use 1063398 for Foodmaker units</i>) Dual-vat (Non-CE Export) (<i>not available for CE Units</i>) Full-vat (Domestic U.S.) (<i>use 1063364 for Foodmaker units</i>) Full-vat (Non-CE Export) (<i>not available for CE Units</i>)
*		8064323	Fallback Controller Assembly, Dual-vat
*		8069224	Fallback Controller Assembly, Full-vat
*		2105623	Blank Panel (<i>for fryers with remote mounted computers</i>)
*		8062071	15-pin Wiring Harness, Computer-to-Interface Board
*		1061226	Remote Computer, Burger King
*		8063528	Internal Cable, 7 1/2-feet
*		8063531	Internal Cable, 12 1/2-feet
*		8063388	External Cable, 20-feet
5		1082169SP	K3000 Controller H-55

* Not illustrated.

* Pro H50/55-Series cabinets were manufactured with standard cabinets with the 90°-edge topcap and the Euro-Look cabinets with the rounded topcap. The Euro-Look cabinets also have a separate bezel. The computers that fit the appropriate cabinet are not interchangeable.

2.5 Drain, Filtration, and Oil Return System Components

2.5.1 Filtration System Components

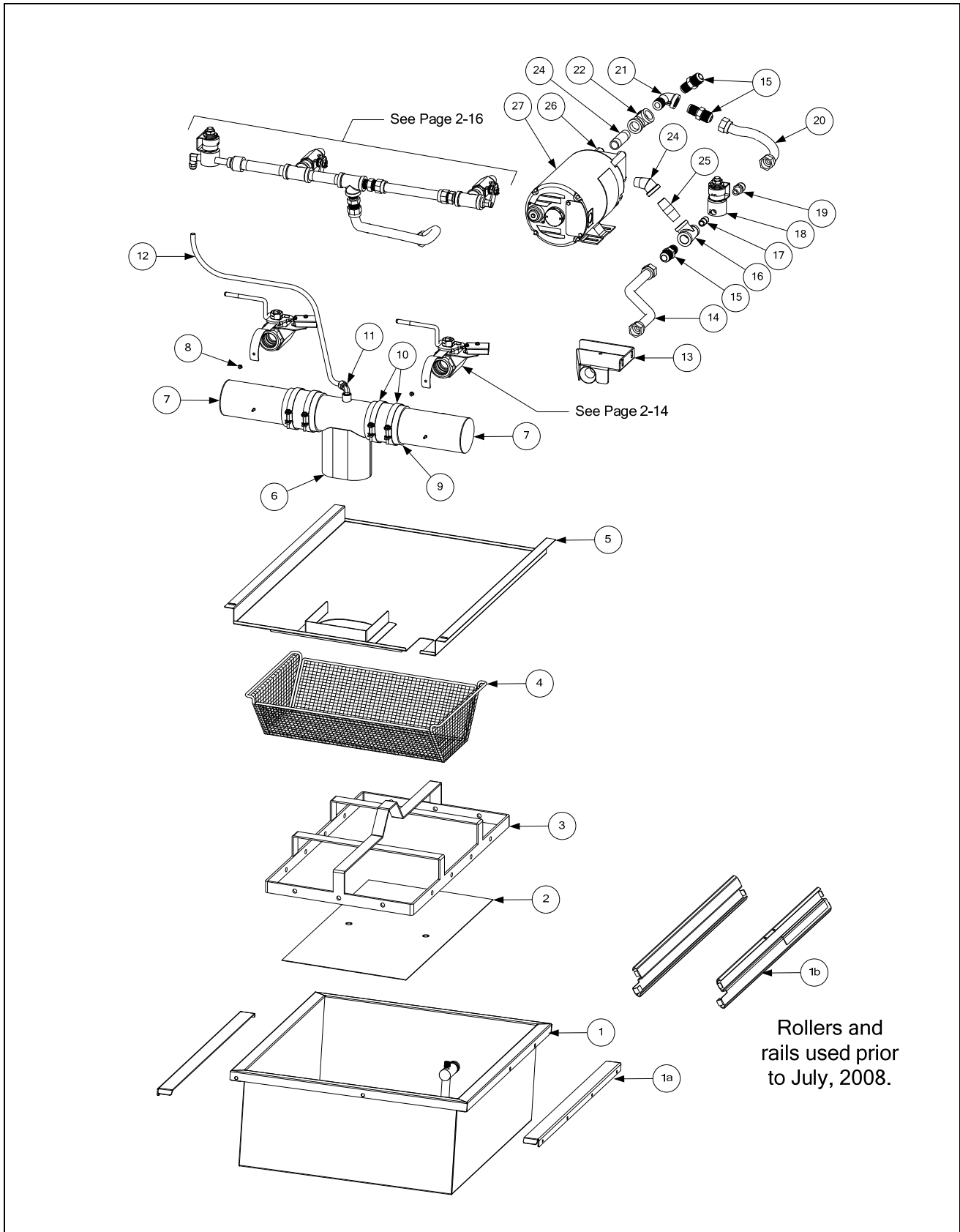

ITEM	PART #	COMPONENT
1	1080181SP	Filter Pan, Slide-type, FootPrint Pro <i>(after July, 2008; includes plug and o-rings)</i>
	8130568	Plug, 1/8-inch NPT Socket Head
	8160596	O-Ring <i>(two required)</i>
*	8261980	Filter Pan, Roller-type, FootPrint Pro <i>(prior to July, 2008; includes next 4 items)</i>
	8130568	Plug, 1/8-inch NPT Socket Head
	8160012	O-Ring <i>(two required)</i>
	8102198	Roller, Filter Pan <i>(See NOTE at bottom of page.)</i>
	8090059	Nut, 1/4-20 Hex Flange <i>(See NOTE at bottom of page.)</i>
1a	2203879	Filter Pan Rail, Slide-type <i>(after July, 2008)</i>
1b	8262603	Filter Pan Rail, Roller-type <i>(prior to July, 2008; includes one left and one right)</i>
2	2002124	Screen, Sana Grid
3	8102091	Ring, Filter Paper Hold-Down Ring <i>(13.47-inch X 21.41-inch)</i>
4	8235146	Tray, Filter Pan Crumb
5	8234662	Lid, Filter Pan
6		Tube, 3-inch Center Drain
	8234678	Open Both Ends
	8234708	Closed One End
7		Tube, 3-inch Round Drain <i>(8234625 illustrated)</i>
	8234638	Dual Vat, Long <i>(one end closed)</i>
	8234640	Dual Vat, Long <i>(open both ends)</i>
	8234624	Dual Vat, Short <i>(one end closed)</i>
	8234642	Dual Vat, Short <i>(open both ends)</i>
	8234639	Full Vat, Long <i>(one end closed)</i>
	8234641	Full Vat, Long <i>(open both ends)</i>
	8234625	Full Vat, Short <i>(one end closed)</i>
	8234643	Full Vat, Short <i>(open both ends)</i>
	2006473	Spreader, Long <i>(open both ends, no drain valve connection)</i>
	2006474	Spreader, Short <i>(open both ends, no drain valve connection)</i>
8	8090247	Nut, 8-32 Hex Keys
9	8160625	Sleeve, Round Drain Connector
10	8090969	Clamp, Round Drain Sleeve
11	8102493	Elbow, 1/4-inch NPT X 90° Tube Compression
12	8111071	Tube, 1/4-inch OD Teflon Manifold Vent
13	8233879	Suction Tube, FootPrint Pro Female
14	8101055	Flexline, 5/8-inch OD X 11.50-inch
15	8101668	Adapter, 5/8-inch OD X 1/2-inch Male
16	8130530	Tee, 1/2-inch X 1/2-inch X 1/4-inch Reducing
17	8130838	Nipple, 1/4-inch NPT Close
18	1067598SP	Solenoid Valve w/Female Pins
19	8102773	Adapter, 1/4-inch NPT to 1/2-inch NPT
20	8101067	Flexline, 5/8-inch OD X 8.50-inch
21	8130165	Elbow, 1/2-inch NPT X 90° Street
22	8130003	Tee, 1/2-inch NPT
23	8130265	Nipple, 1/2-inch NPT X 2.50-inch
24	8130342	Elbow, 1/2-inch NPT X 45° Street
25	8130298	Nipple, 1/2-inch NPT X 2.00-inch
26	8263191	Pump and Gasket Kit <i>(for gasket only, order P/N 8160093)</i>
27		Motor and Gasket Kit, 50/60 Hz <i>(for gasket only, order P/N 8160093)</i>
	8261785	100V
	8261712	115V
	8261756	208V
	8261757	220-240V
	8261755	250V
*	1060675	Plumbing Assembly <i>(used with rear flush, page 2-19)</i>

* Not illustrated. **NOTE:** Kit 8261979 contains four each of roller 8102198 and 1/4-20 Flange Nut 8090059.

2.5.2 Drain Valves and Associated Components

Non-Filter Drain Valve Assemblies

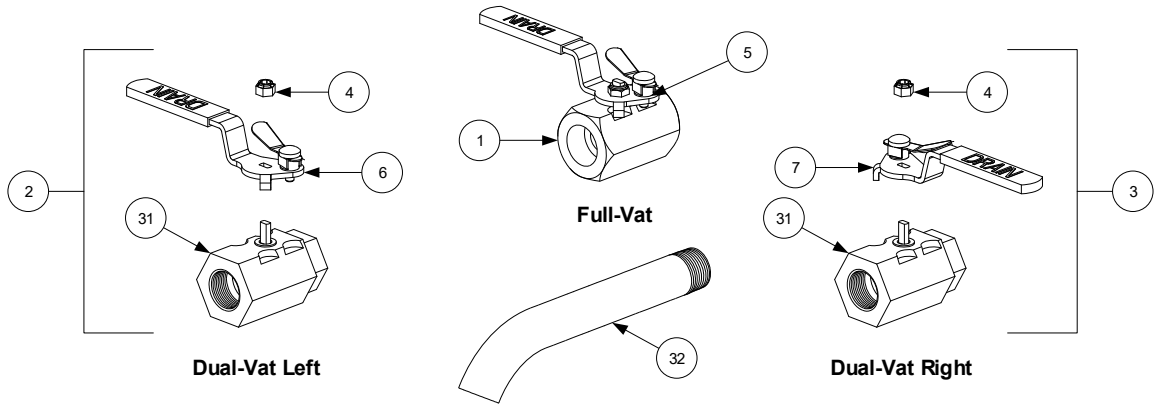

FootPrint and Filter Magic Drain Valve Assemblies

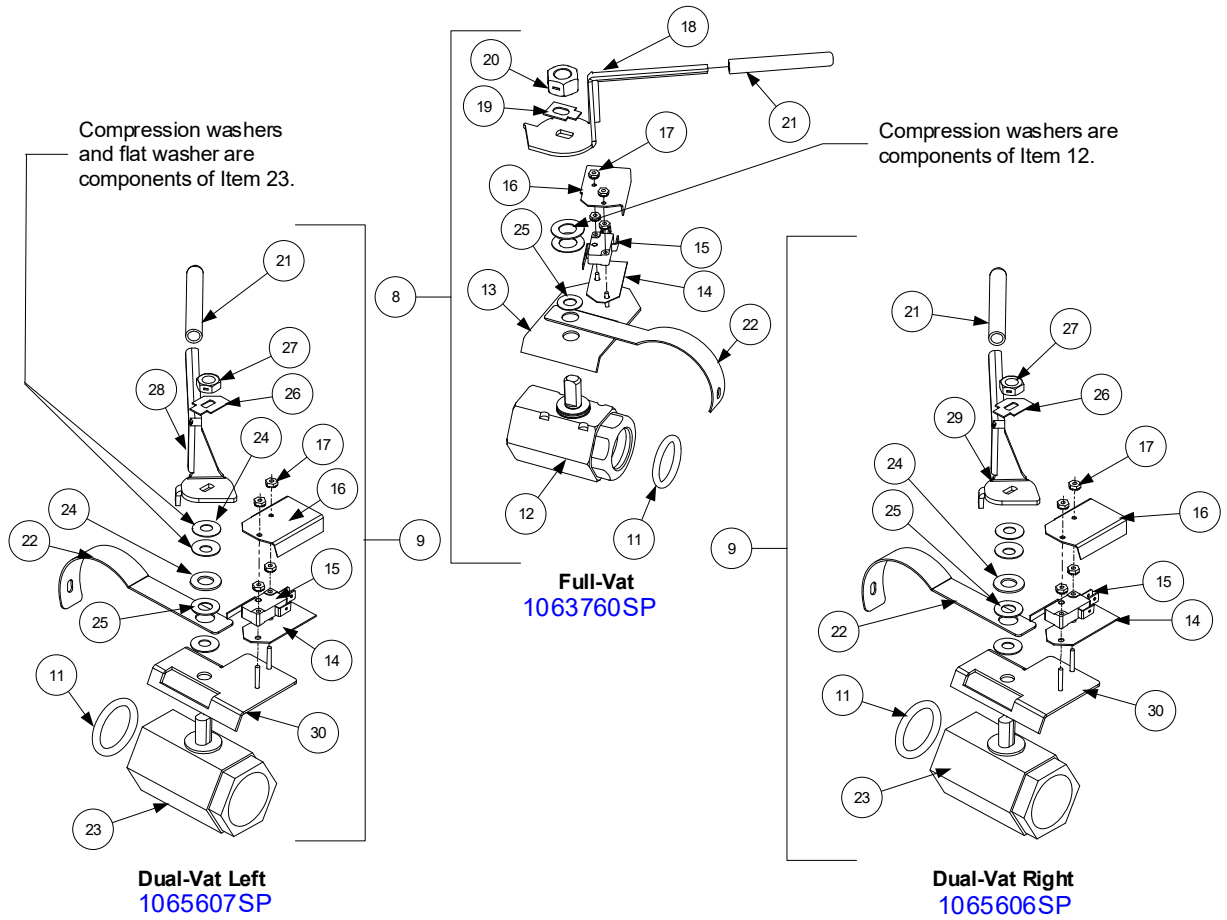

ITEM	PART #	COMPONENT
1	8101569	Valve Assembly, 1.25-inch Full-Vat Non-Filter Drain (includes handle)
*	8101427	Lock Pin Handle for 1.25-inch Valve Assembly
2	8067915SP	Valve Assembly, 1-inch Left Dual-Vat Non-Filter Drain (complete assembly)
3	8067916SP	Valve Assembly, 1-inch Right Dual-Vat Non-Filter Drain (complete assembly)
4	8090589	Nut, ½-13 2-Way Lock (used on non-filter drain valves)
5	8101427	Handle w/Lock Pin, Full Vat
6	8101568	Handle w/Lock Pin, Left Drain Valve Dual Vat
7	8101567	Handle w/Lock Pin, Right Drain Valve Dual Vat
8	1063760SP	Valve Assembly, 1.25-inch Full-Vat w/Filter Drain (complete assembly)
9	1065607SP	Valve Assembly, 1-inch Left Dual-Vat w/Filter Drain (complete assembly)
10	1065606SP	Valve Assembly, 1-inch Right Dual-Vat w/Filter Drain (complete assembly)
11	8160135	O-Ring, Drain Valve
12	8101018	Valve, 1.25-inch Drain
13	8068137	Bracket Assembly, Drain Safety Switch
14	8160220	Insulation, Drain Safety Switch
15	8072103	Microswitch, Lever Activated
16	9012348	Cover, Drain Safety Switch
17	8261366	Nut, 4-40 Hex Keps (Pkg. of 25)
18	8241602	Handle, Full-Vat Drain Valve
19	9002936	Retainer, Full-Vat Drain Valve Nut
20	8090540	Nut, ½-13 2-Way Lock
21	8160639	Grip, Drain Valve Handle
22	2006496	Support, 3-inch Drain Tube
23	8101114	Valve, 1-inch Dual-Vat w/Filter Drain
24	8090196	Washer, ⅜-inch Flat
25	8101165	Washer, ⅜-inch Teflon
26	9002934	Retainer, Dual-Vat Drain Valve Nut
27	8090539	Nut, ⅜-16 2-Way Lock
28	8241637	Handle, Left Dual-Vat Drain Valve
29	8241636	Handle, Right Dual-Vat Drain Valve (Must order item 16 and item 30 to fit)
30	1062671	Bracket Assembly, Dual-Vat Drain Safety Switch
31	8101338	Valve, 1-Inch Dual-Vat Non-Filter Drain
32		Drain Valve Extension
	8121226SP	Full-Vat (1.25-inch)
	8121227	Dual-Vat (1-inch)

2.5.3 Oil Return Line Components

There are more than 160 oil return line combinations. The three examples shown are typical. These examples identify all of the components used in the various configurations, but not all of the components identified are used in every configuration or in only the position shown.

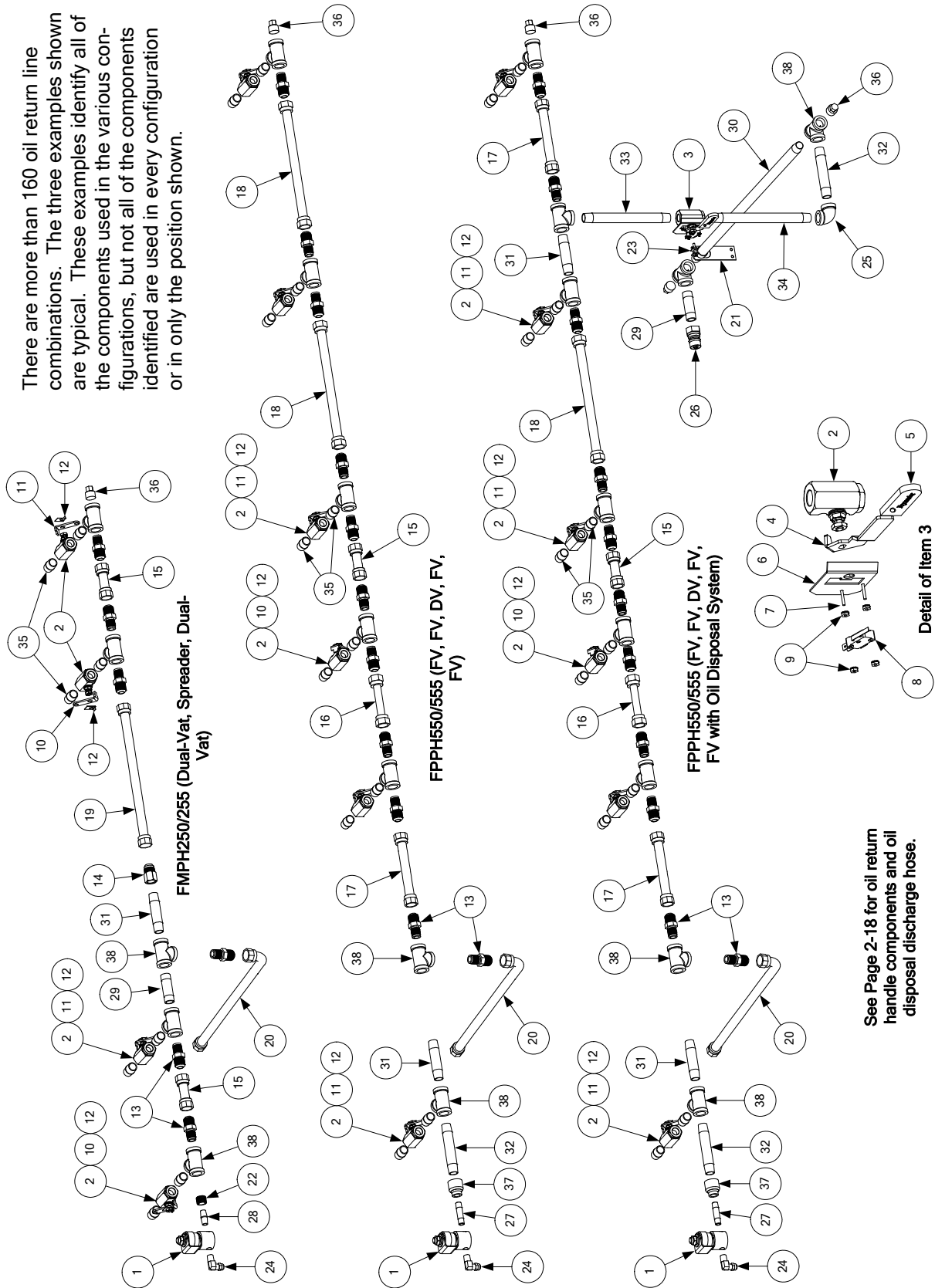

See Page 2-18 for oil return handle components and oil disposal discharge hose.

ITEM	PART #	COMPONENT
1	8072484	Valve, 1/4-inch NPT Solenoid
2	8100278	Valve, 1/2-inch NPT Ball
3	8068762SP	Valve Assembly, Microswitch and Ball
4	9005953	Handle, Oil Discharge Valve
5	8140047	Sleeve, Red Handle
6	9008057	Mount, Microswitch
7	8090354	Screw, 4-40 X 3/4-inch Slotted Round Head
8	8072103	Microswitch, Lever Activated
9	8090237	Nut, 4-40 Keps Hex
10	2015721	Arm, Left Dual-vat Oil Return Valve
11	2025721	Arm, Right Dual-vat or Full-Vat Oil Return Valve
12	9002935	Retainer, Oil Return Valve Nut
13	8101668	Adapter, Flexline to 1/2-inch NPT Male
14	8101669	Adapter, Flexline to 1/2-inch NPT Female
15	8101160	Flexline, 3.00-inch
16	8101339	Flexline, 4.50-inch
17	8101680	Flexline, 6.50-inch
18	8101055	Flexline, 11.50-inch
19	8101057	Flexline, 13.00-inch
20	8101400	Flexline, 21.00-inch
21	9100889	Bracket, Oil Discharge Plumbing
22	8130304	Bushing, 1/2-inch to 1/4-inch NPT Reducer
23	8090951	Clamp, 1/2-inch Hose
24	8101372	Fitting, 1/4-inch HPTF X 3/8-inch Tube 90°
25	8130062	Elbow, 1/2inch NPT 90°
26	8100487	Fitting, Male Quick-Disconnect
27	8130537	Nipple, 1/4-inch NPT X 2.00-inch
28	8130077	Nipple, 1/4-inch NPT X Close
29	8130265	Nipple, 1/2-inch NPT X 2.50-inch
30	8130541	Nipple, 1/2-inch NPT X 25.50-inch
31	8130247	Nipple, 1/2-inch NPT X 3.50-inch
32	8130251	Nipple, 1/2-inch NPT X 4.50-inch
33	8130320	Nipple, 1/2-inch NPT X 8.00-inch
34	8130275	Nipple, 1/2-inch NPT X 9.00-inch
35	8130022	Nipple, 1/2-inch NPT X Close
36	8130156	Plug, 1/2-inch NPT Pipe
37	8130555	Reducer, 1/2-inch to 1/4-inch NPT Bell
38	8130003	Tee, 1/2-inch NPT

2.5.4 Oil Return Handle, Oil Disposal and Disposal Hose Components

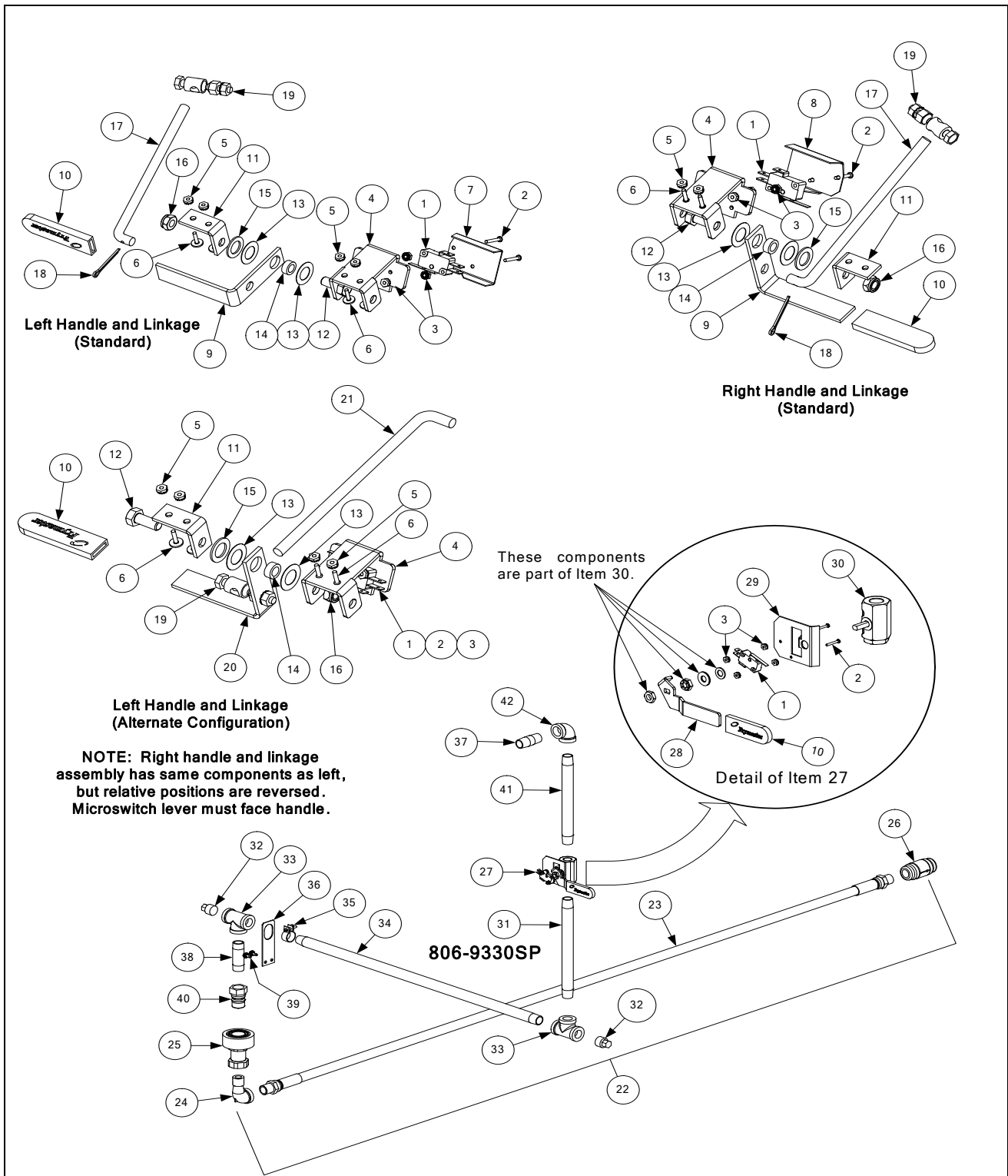

ITEM	PART #	COMPONENT
1	8072103	Microswitch, Lever Activated
2	8261359	Screw, 4-40 X 3/4-inch Slotted Round Head
3	8090237	Nut, 4-40 Hex Keps
4	2000821	Bracket, Handle
5	8090247	Nut, 8-32 Hex Keps
6	8261363	Screw, 8-32 X 1/2-inch Slotted Truss Head (pkg. of 25)
7	9012358	Cover, Left Handle Microswitch
8	9022358	Cover, Right Handle Microswitch
9	2002437	Handle, Oil Return (<i>use in standard configurations, see example – page 2-17</i>)
10	8140047	Sleeve, Red Handle
11	8101999	Bracket, Oil Return Handle
12	8090142	Bolt, 5/16-24 X 3/4-inch Hex Head
13	8090203	Washer, 1/2-inch Flat Nylatron
14	8100220	Spacer, .493-inch X .200-inch Tubular
15	8090200	Washer, 1/2-inch Flat Steel
16	8090056	Nut, 5/16-24 Hex Lock
17	2002438	Rod, Oil Return Linkage (<i>use in standard configurations, see example – page 2-17</i>)
18	8100783	Cotter Pin
19	8100285	Swivel, Valve Control
20	9200831	Handle, Oil Return (<i>use in alternate configurations, see example – page 2-17</i>)
21	9100632	Rod, Oil Return Linkage (<i>use in alternate configurations, see example – page 2-17</i>)
22	8069178SP	Hose Assembly, Oil Discharge (<i>Items 23-26</i>)
23	8101434	Hose Assembly, 66-inch Oil
24	8130165	Elbow, 1/2-inch X 90° Street
25	8100490	Quick-Disconnect Fitting, 1/2-inch Female
26	8100667	Check-Valve, 1/2-inch
*	8069330SP	Oil Disposal Plumbing Assembly (rear discharge configuration)H50 Oil Return
27	8068762SP	Ball Valve with Microswitch Assembly
28	9005953	Handle, Oil Disposal Mounting
29	9008057	Bracket, Microswitch Mounting
30	8100278	Valve, ½-inch Gemini (without handle)
31	8130275	Nipple, ½-inch x 9-inch
32	8130463	Plug, ½-inch Pipe Counter Sink
33	8130003	Tee, ½-inch x ½-inch x ½-inch
34	8130607	Nipple, ½-inch x 2 ½-inch
35	8090951	Clamp, Hose (limits movement of plumbing through mounting bracket)
36	9108809	Bracket, Oil Disposal Mounting (rear connection configuration)
37	8130298	Nipple, ½-inch x 2-inch
38	8130265	Nipple, ½-inch x 2 ½ -inch
39	8261374	Screw, #10 x ½-inch Hex Head (Pkg. of 25)
40	8100487	Quick Disconnect, ½-inch Male
41	8130320	Nipple, ½-inch x 8-inch
42	8130062	Elbow, ½-inch x 90°
*	8262113	Kit, FMP/FPPH50 Rear Disposal Kit (Three or more vats/spreaders only)

2.5.5 Oil Disposal Wand Assembly

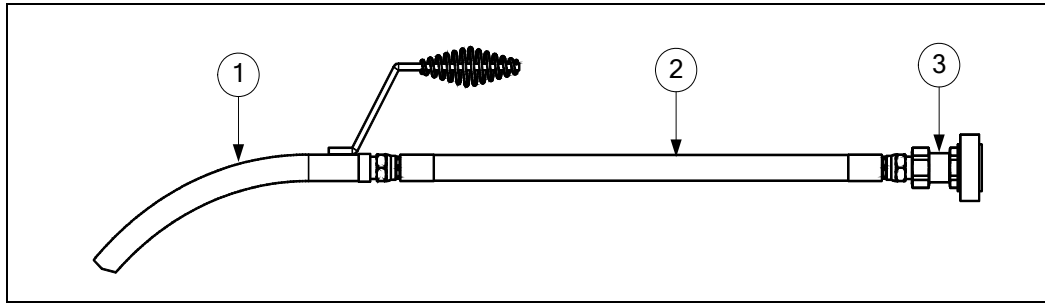

ITEM	PART #	COMPONENT
	8067459	Assembly, Oil Disposal Wand
1	8100603	Wand, FB Filter
2	8101471	Hose, 24 FPH50/55
3	8100490	Quick Disconnect, 1/4-inch Female

2.5.6 Assembly Wand Plumbing (Japan)

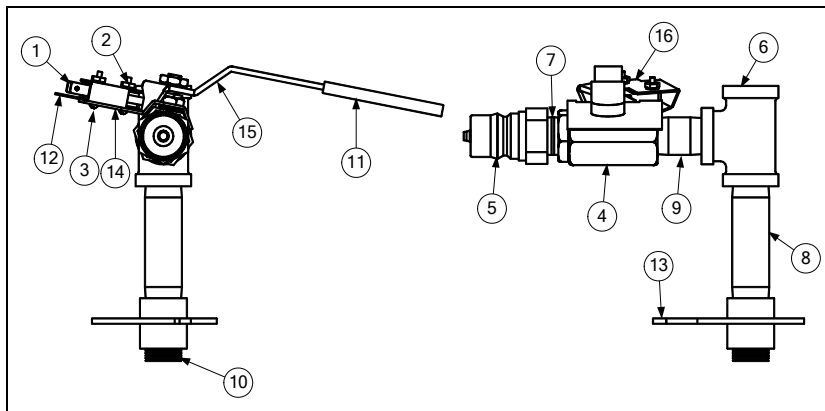

ITEM	PART #	COMPONENT
	8069700SP	Plumbing Assembly, Japan Wand
1	8072103	Switch, CE Micro
2	8261366	Nut, 4-40 (Pkg. of 25)
3	8261359	Screw, 4-40 x 3/4 (Pkg. of 25)
4	8100278	Valve, 1/2-inch Ball
5	8100487	Coupling, Male
6	8130003	Tee, 1/2 x 1/2 x 1/2
7	8130002	Nipple, 1/2 x Close NPT
8	8130156	Plug, 1/2 NPT
9	8130247	Nipple, 1/2 x 3 1/2-inch NPT
10	8130298	Nipple, 1/2 x 2-inch NPT
11	8140047	Sleeve, Handle Valve Red w/ Logo
12	8160220	Insulation, RF Switch
13	8232029	Support, Oil Return
14	9001862	Bracket, Microswitch Mounting 1/2 Ball Valve
15	9002839	Handle, Valve Wand Japan
16	9002849	Cover, Wand Microswitch Japan

ITEM	PART #	COMPONENT
1		Valve Assembly, Microswitch and Ball Valve
	1063452	Valve, Rear Flush Assembly, Left Side
	1063453	Valve, Rear Flush Assembly, Right Side
2	8102493	Elbow, 90° x ¼-inch NPT x ¼-inch Tube
3	8090601	Clip, Rod End Clevis
4		Shaft, Rear Flush Valve
	2116701	For use in Left oil return valve assemblies
	2126701	For use in Right oil return valve assemblies
5		Handle, Rear Flush Valve
	9012772	For use in Left oil return valve assemblies
	9022772	For use in Right oil return valve assemblies
6	8130165	Elbow, 90° x ½-inch Street
7	8130087	Nipple, 1 ½-inch BM NPT
8	8102201	Valve, ½-inch Ball
*	9002935	Oil Return Valve Nut Retainer
9	8101668	Adapter, ⅝-inch Flexline to ½-inch NPT Male
9a	8102786	Adaptor, ½ -inch Flare x ½ -inch NPT
10	8072484	Valve, ¼-inch NPT Solenoid Vent
11		Manifold Rear Flush Oil Return
	8102890	Two-Station Fryer
	8102891	Three-Station Fryer
	8102892	Four-Station Fryer
	8102893	Five-Station Fryer
12	8130156	Cap, ½-inch Pipe
13	8160220	Insulation, Rear Flush Switch
14	8074101	Microswitch, Lever Activated
15	8261366	Nut, 4-40 Keps Hex (Pkg. of 25)
16	8261359	Screw, 4-40 x ¾-inch Slotted Round Head (Pkg. of 25)
17	8090250	Nut, 6-32 Keps Hex
18	2008745	Cover, Microswitch Rear Flush
19	8070125	Bushing, .50 ID Heyco SB-750-8 Nylon
20	8130700	Nipple, ¼-inch NPT x 3-inch
21	8160643	Grip, Oil Return Handle
22	8101067	Flexline, ⅝-inch OD x 8.5-inch Oil Return
23	8102787	Flexline, ½-inch x 5-inch Oil Return Manifold to Pump
24	8101055	Flexline, ⅝-inch OD x 11½-inch Oil Return Manifold to Pump
25	8111071	Tube, ¼-inch OD Teflon Manifold Vent

2.5.8 Power Shower Assemblies (Optional)

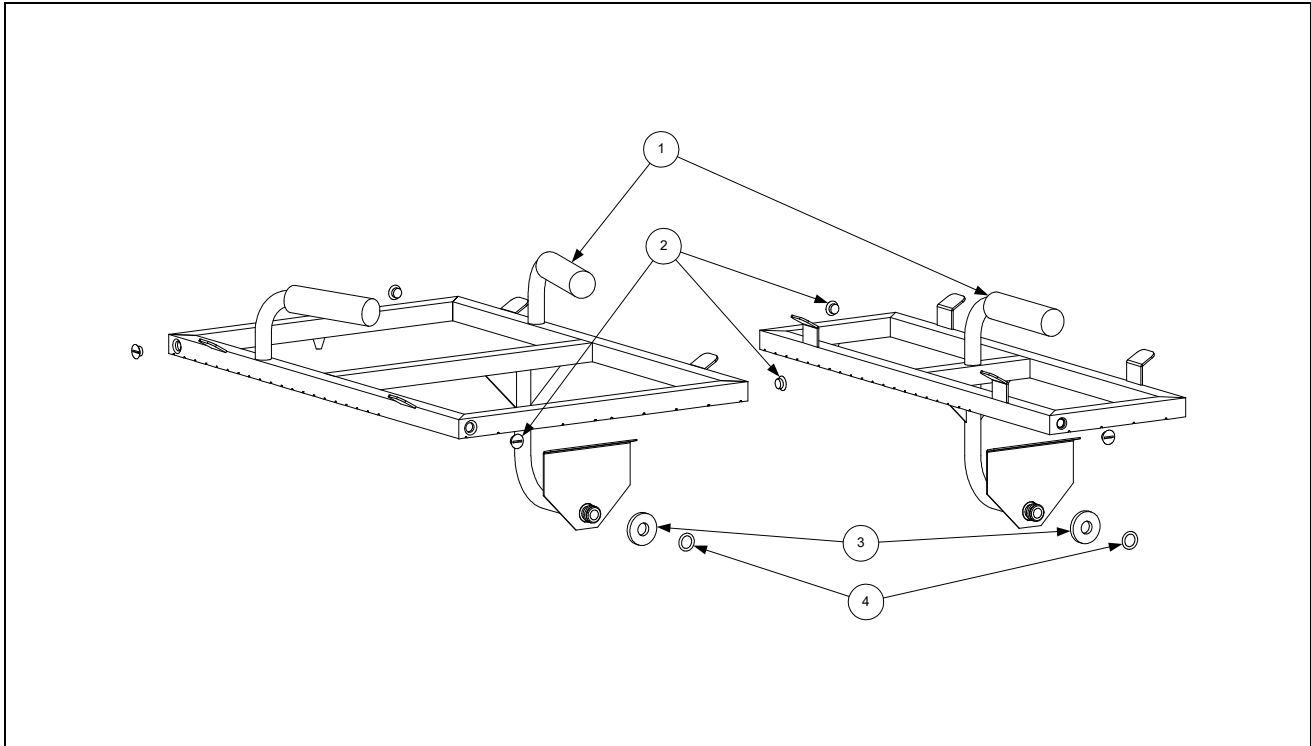

ITEM	PART #	COMPONENT
	8064442SP	Power Shower Assembly, Full-vat, Complete
	8064476SP	Power Shower Assembly, Dual-vat, Complete
1	8140001	Grip, Handle
2	8090415	Screw, Cleanout
3	8261390	Seal (<i>Gasket</i>) (pkg. of 5)
4	8261344	O-Ring (pkg. of 5)

2.6 Electronics and Electrical Components (for Controllers, Page 2-10)

2.6.1 Component Boxes

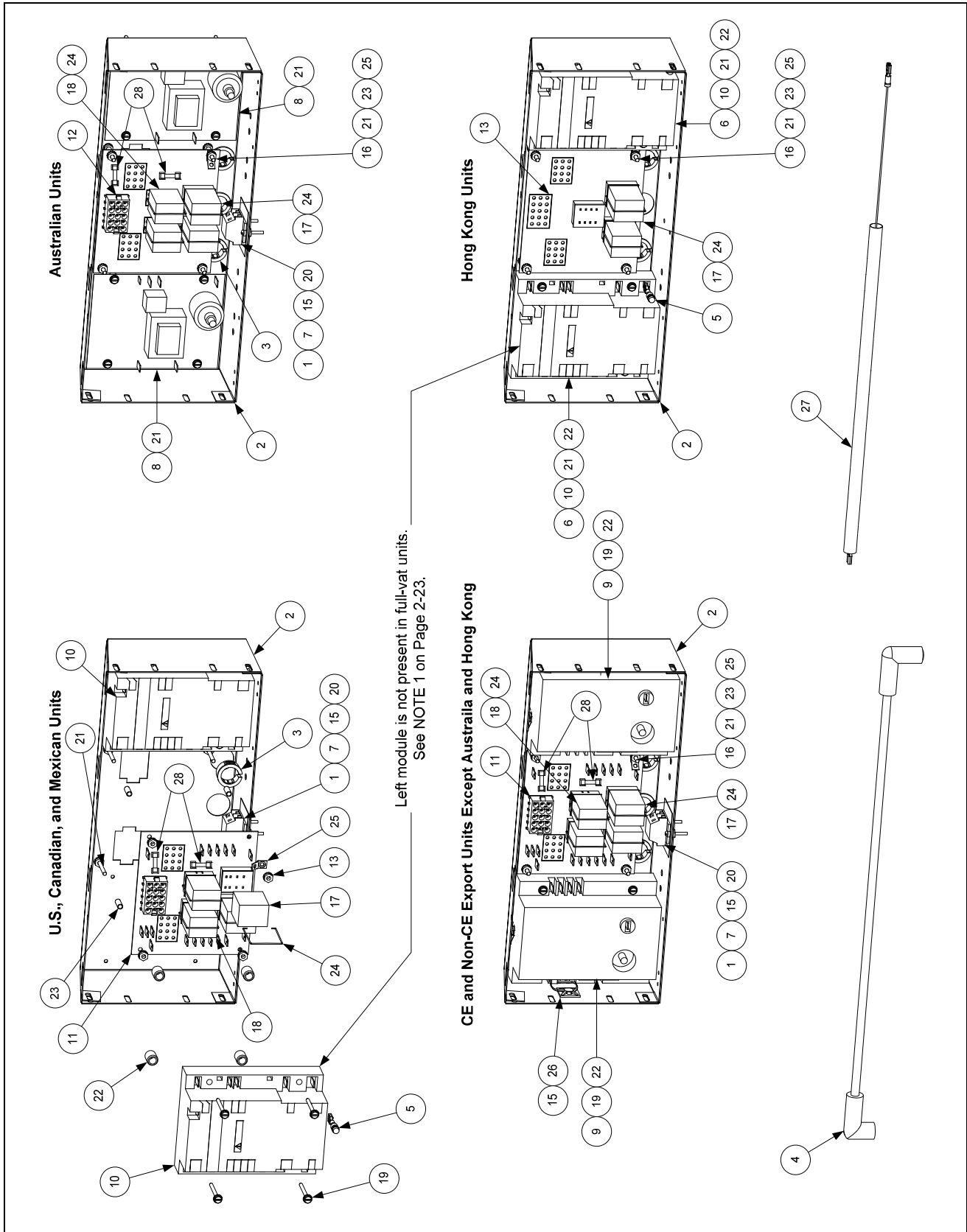

ITEM	PART #	COMPONENT
1	8101164	Block, One-Piece Screwless Terminal
2	2005996	Box, One-Piece Component
3	8071926	Bushing, .875-inch Split
4	8262024	Cable, 21-inch Ignition (<i>comes with Rajah connector [Item 5]</i>)
5	8073484	Connector, Rajah
6	1060531SP	Fuse Assembly, Inline
7	8160217	Insulation, Terminal Block Paper
8	8072971	Ignition Module, Australian prior to 04/2021
	8076382	Ignition Module, Australia/NZ 3 sec. FV Left, DV Fenwal 04/2021 to current
	8076383	Ignition Module, Australia/NZ 4 sec. FV Right Fenwal 04/2021 to current
9	8071006	Ignition Module, CE and Non-CE export (<i>except Australia, Canada, HK, Mexico</i>)
10	8073366†	Ignition Module, Dual-Spark Full-vat (<i>U.S., Canadian, HK, and Mexican units</i>)
	8073365†	Ignition Module, Single-Spark Ignition Module Dual-vat (<i>U.S., Canadian, HK, and Mexican units</i>)
	8075949	Ignition Module, Single Spark Fenwal
11	8262264	Interface Board Kit; U.S., CE and non-CE (<i>except Hong Kong</i>)
	1066706	Interface Board SMT, U.S., CE and non-CE (<i>except Hong Kong</i>)
	8074330	Sound Device/Speaker Adapter Harness SMT
	8074343	Wire Harness, SMT Interface Board to Ignition Module
*	1066711	Interface Board, Fast Computer
12	1060387	Interface Board, Australian prior to 04/2021
	8080014	Interface Board, GIVEG Australia/NZ 04/2021 and after (use harness 8076370)
13	8064973	Interface Board, Hong Kong
14	8071359	Mount, Ty-Wrap
15	8070833	Relay, DPDT 5A 12VDC Latch/Heat (<i>See NOTE 1</i>)
16	8070834	Relay, SPDT 15A 12VDC Basket Lift (<i>See NOTE 2</i>)
17	8261346	Spacer, Ignition Module (Pkg. of 10)
18	8102763	Spacer, Interface Board
19	8102243	Spring, Relay Retaining
20	8261337	Tab, 1/4-inch Terminal (Pkg. of 5)
21	8071948	Ty-Wrap
22	8066085	Wire Assembly, Ignition Module
23	8073843	Fuse 3A 250V Domestic
	8073293	Fuse 5A 125V International Only
*	8261721	Ignition Cable (<i>2 ignition cables, 2 rajah connectors</i>)
*	8071200	Ignition Wires, 27-inch (<i>used with 8071006</i>)
*	8071878	Ignition Wires, 19-inch (<i>used with 8071006</i>)
*	8075986	Harness, Fenwal Module FV
*	8075987	Harness, Fenwal Module DV
*	1088328	Wire Assy, Flame Sense (used with 8076382 and 8076383)
*	8063660	Sound Device, High Output (use 8103141 for SMT sound device with SMT connector)

* Not illustrated.

† For dual-vat units, use 8073365 Single-Spark Ignition Module (see **NOTE 1**).

NOTE 1: U.S., Canadian, Hong Kong, and Mexican units use two different modules depending upon the configuration of the frypot. Dual-vat units use two 8073365 Single-Spark Ignition Modules. Full-vat units use one 8073366 Dual-Spark Ignition Module. Also, in full-vat units, only one latch relay (Item 17) is used, located in the lower right socket.

NOTE 2: Basket Lift Relays (Item 18) are present only on units equipped with basket lifts.

2.6.2 Transformer Boxes

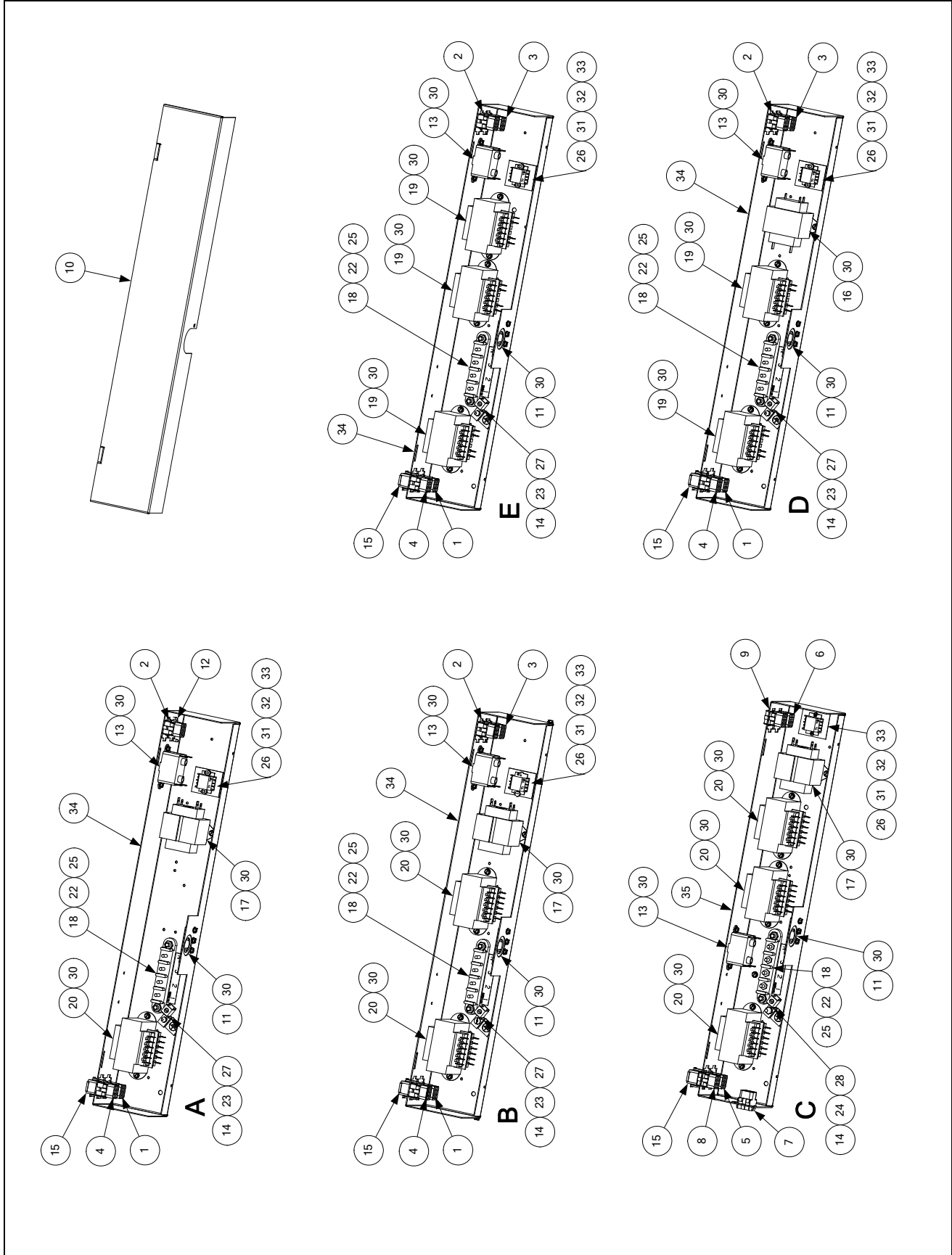

ITEM	PART #	COMPONENT
		Box Assembly, Transformer
A	1061380SP	100-120V FMPH150/155, FMPH350/355, FMPH450/455
B	1060627SP	100-120V FMPH250/255, FMPH350/355, FMPH450/455, FPPH250/255, FPPH350/355, FPPH450/455
C	1063308SP	100-120V FMPH450/455, FPPH350/355
D	1063433SP	208-240V FMPH250/255 CE/Non-CE Export, FPPH250/255 CE/Non-CE Export
E	1063432SP	250V FPPH250/255 CE/Non-CE Export
1	1061009	Cable Assembly, Transformer Box #1
2	1061010	Cable Assembly, Transformer Box #2
3	1061011	Cable Assembly, Transformer Box Line
4	1061016	Cable Assembly, Transformer Box Filter Pump
5	1063311	Cable Assembly, Transformer Box #1
6	1063312	Cable Assembly, Transformer Box #2
7	1063313	Cable Assembly, Transformer Box #3
8	1063314	Cable Assembly, Transformer Box Filter Pump
9	1063316	Cable Assembly, Transformer Box Line
10	2001415	Cover, Transformer Box
11	2002260	Plate, Strain Relief
12	2002318	Cover, Transformer Box Cable
13	8070012	Relay, 18 Amp 1/3-HP 24V Coil
14	8070070	Terminal, Ground Lug
15	8070155	Connector, 9-Pin Male
16	8070680	Transformer, 208-240V/24VAC 50/60Hz 20VA
17	8070800	Transformer, 120V/24VAC 50/60Hz 50VA
18	8071973	Terminal, Post
19	8071999	Transformer, 208-240V V/F Dual Voltage
20	8072176	Transformer, 100-120V V/F Dual Voltage
21	8090052	Nut, 10-24 Hex
22	8090071	Nut, 1/4-20 Hex
23	8090103	Screw, 8-32 X 1/2-inch Slotted Truss Head
24	8090123	Screw, 10-24 X 3/4-inch Slotted Truss Head
25	8090131	Screw, 1/4-20 X 3/4-inch Hex Head
26	8090237	Nut, 4-40 Keps Hex
26	8090247	Nut, 8-32 Keps Hex
28	8261376	Nut, 10-32 Keps Hex
29	8090354	Screw, 4-40 X 3/4-inch Slotted Round Head
30	8090360	Screw, #8 X 3/8-inch Hex Washer Head
31	8090656	Screw, 4-40 X 3/8-inch Slotted Round Head
32	8101164	Block, One-Piece Screwless Terminal
33	8160217	Insulation, Terminal Block Paper
34	8241242	Box, Transformer
35	8241243	Box, Transformer
*	WIR0439	Wire Assembly, Transformer Box <i>(used in Items B, D, and E)</i>
*	WIR0447	Wire Assembly, Transformer Box <i>(used in Item A)</i>
*	WIR0580	Wire Assembly, Transformer Box <i>(used in Item C)</i>

* Not illustrated.

2.6.3 High-Limit Thermostat and Temperature Probe

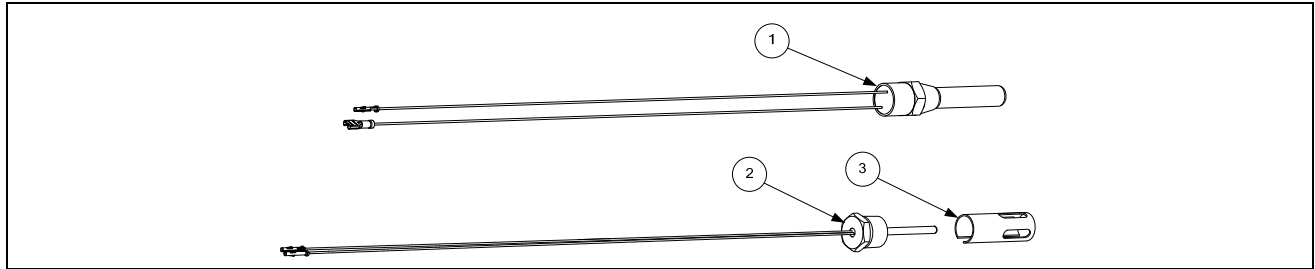

ITEM	PART #	COMPONENT
1	8261177	High Limit Thermostat - 425°F/218°C
2	8064206	Temperature Probe
3	2100681	Probe Guard

2.7 Frypots and Associated Components

2.7.1 Full-Vat Frypot Components

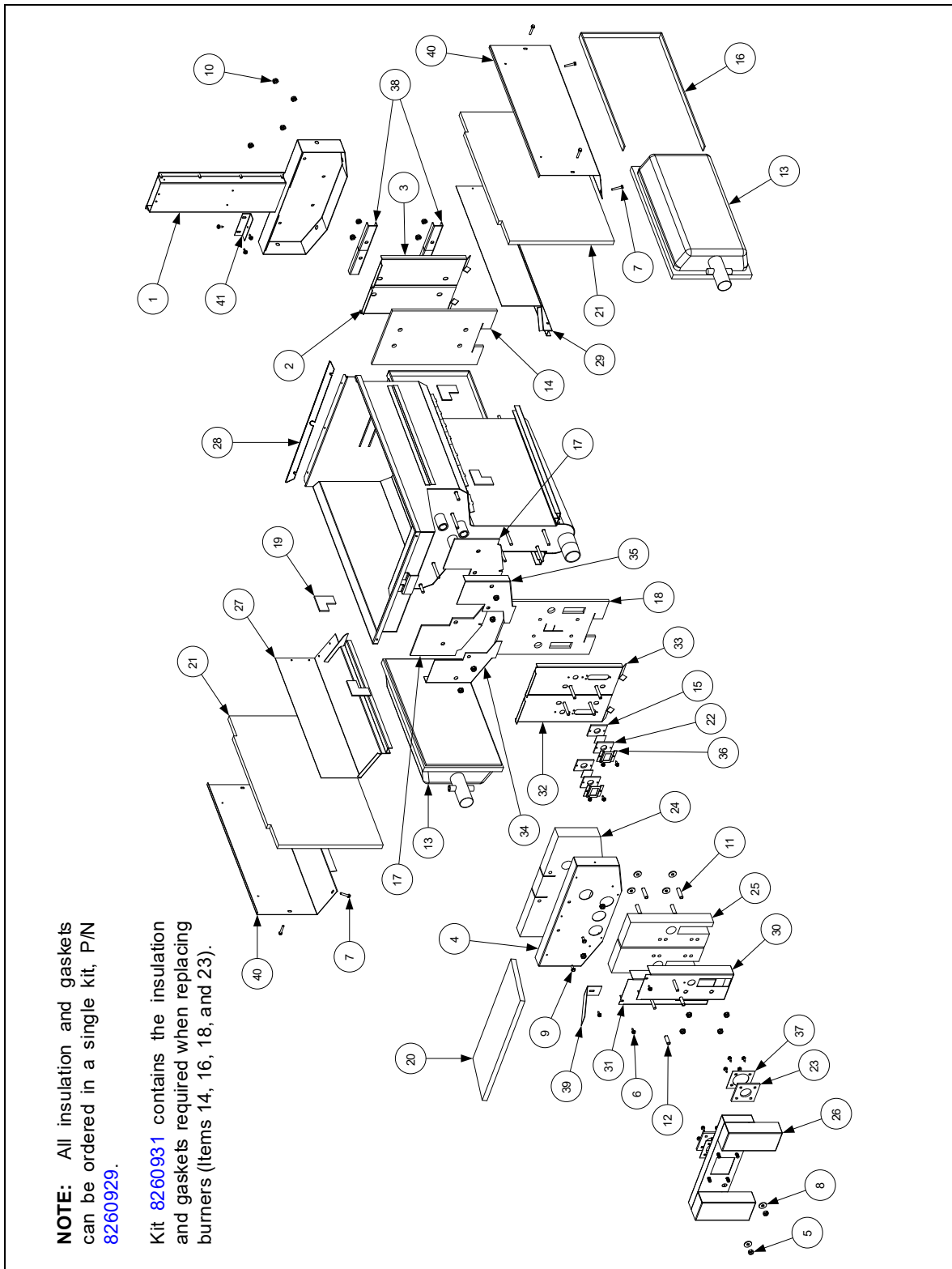

ITEM	PART #	COMPONENT
1	1061019SP	Flue Assembly, Full-vat
2	2000936	Back, Left Full-vat Combustion Chamber
3	2000937	Back, Right Full-vat Combustion Chamber
4	2002227	Retainer, Full-vat Upper Insulation
5	8090059	Nut, 1/4-20 Flange Hex
6	8090361	Screw, #8 X 1/2-inch Hex Head Drill Point
7	8090362	Screw, #8 X 1 1/4-inch Hex Washer Head Drill Point
8	8090435	Washer, Steel
9	8090500	Screw, #10 X 1/2-inch Hex Washer Head 410 SS
10	8090804	Nut, 1/4-20 Keps Hex
11	8100476	Spacer, .25-inch X 1.187-inch
12	8100500	Spacer, .25-inch X .9375-inch
13	8261072	Burner, Universal Replacement
14	8120355	Insulation, Full-vat Lower Rear
15	8120356	Insulation, Burner Sight Glass
16	8160577	Insulation, Burner
17	8120404	Insulation, Left or Right Front Seal
18	8120457	Insulation, Full-vat Lower Front
19	8120706	Insulation, Upper Burner Rail
20	8120993	Insulation, Upper Oil Zone
21	8121029	Insulation, Combustion Chamber Side
22	8140048SP	Glass, Burner Sight
23	8160057	Gasket, Plenum
24	8160560	Insulation, Full-vat Upper Front
25	8160561	Insulation, Left or Right Outer Front
26	8230969	Plenum, Full-vat
27	8231777	Side and Rail, Left Full-vat Combustion Chamber
28	9004253	Strip, Fluecap Retainer
29	8233142	Side and Rail, Right Full-vat Combustion Chamber
30	8233304	Front, Full-vat Right Combustion Chamber
31	8233305	Front, Full-vat Left Combustion Chamber
32	8233315	Retainer, Left Full-vat Lower Front Insulation
33	8233316	Retainer, Right Full-vat Lower Front Insulation
34	8240863	Retainer, Left Full-vat Upper Insulation
35	8240864	Retainer, Right Full-vat Upper Insulation
36	9001031	Retainer, Burner Sight Glass
37	9001049	Retainer, Plenum Gasket
38	9001221	Retainer, Rear Insulation
39	9001515	Brace, Upper Oil Zone Insulation
40	9004452	Retainer, Combustion Chamber Side Insulation
41	9300818	Bracket, Flue to Frypot
*	8260929	Insulation Kit, Complete Full-Vat
*	8260931	Insulation Kit, Burner Full-Vat
*	1061050SP	Frypot, Complete Assembly, Natural/Propane
*	1061053	Frypot, Complete Assembly, Manufactured Gas

* Not illustrated.

2.7.2 Dual-Vat Frypot Components

NOTE: All insulation and gaskets can be ordered in a single kit, P/N [8260930](#).

Kit [8260932](#) contains the insulation and gaskets required when replacing burners (items 13, 15, 17, and 23).

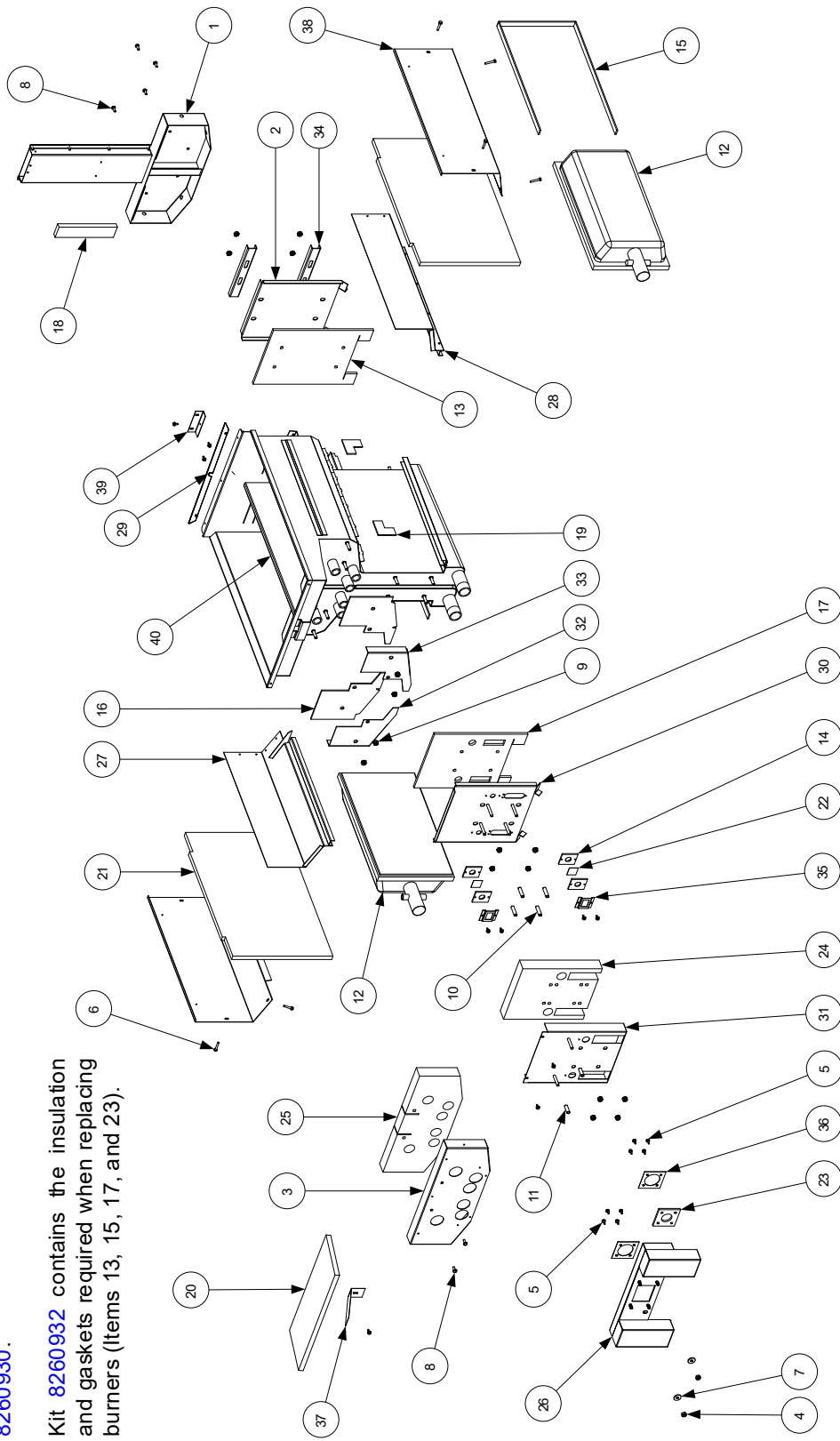

ITEM	PART #	COMPONENT
1	1061018SP	Flue Assembly, Dual-vat
2	2000941	Back, Dual-vat Combustion Chamber
3	2002229	Retainer, Dual-vat Upper Insulation
4	8090059	Nut, 1/4-20 Flange Hex
5	8090360	Screw, #8 X 3/8-inch Hex Head
6	8090362	Screw, #8 X 1 1/4-inch Hex Washer Head Drill Point
7	8090435	Washer, Steel
8	8090500	Screw, #10 X 1/2-inch Hex Washer Head 410 SS
9	8090804	Nut, 1/4-20 Keps Hex
10	8100476	Spacer, .25-inch X 1.187-inch
11	8100500	Spacer, .25-inch X .9375-inch
12	8261072	Burner, Universal Replacement
13	8120354	Insulation, Dual-vat Lower Rear
14	8120356	Insulation, Burner Sight Glass
15	8160577	Insulation, Burner
16	8120404	Insulation, Left or Right Front Seal
17	812458	Insulation, Dual-vat Lower Front
18	8120688	Insulation, Flue Collector
19	8120706	Insulation, Upper Burner Rail
20	8120993	Insulation, Upper Oil Zone
21	8121029	Insulation, Combustion Chamber Side
22	8140048SP	Glass, Burner Sight
23	8160057	Gasket, Plenum
24	8160558	Insulation, Dual-vat Lower Front
25	8160559	Insulation, Dual-vat Upper Front
26	8230970	Plenum, Dual-vat
27	8232822	Side and Rail, Left Dual-vat Combustion Chamber
28	8232823	Side and Rail, Right Dual-vat Combustion Chamber
29	9004253	Strip, Fluecap Retainer
30	8233302	Front, Dual-vat Combustion Chamber
31	8233303	Retainer, Dual-vat Lower Front Insulation
32	8240865	Retainer, Left Dual-vat Upper Insulation
33	8240866	Retainer, Right Dual-vat Upper Insulation
34	9000914	Retainer, Lower Rear Insulation
35	9001031	Retainer, Burner Sight Glass
36	9001049	Retainer, Plenum Gasket
37	9001515	Brace, Upper Oil Zone Insulation
38	9004452	Retainer, Combustion Chamber Side Insulation
39	9300818	Bracket, Flue to Frypot
40	8240541	Riser, DV Pot Divider W/A
*	8260930	Insulation Kit, Complete Dual-Vat
*	8260932	Insulation Kit, Burner Dual-Vat
*	8233327	Frypot, Dual-vat
*	1061080SP	Frypot, Complete Assembly, Natural/Propane

* Not illustrated.

** For rear flush oil return components, see page 2-20.

2.8 Gas Supply and Combustion System Components

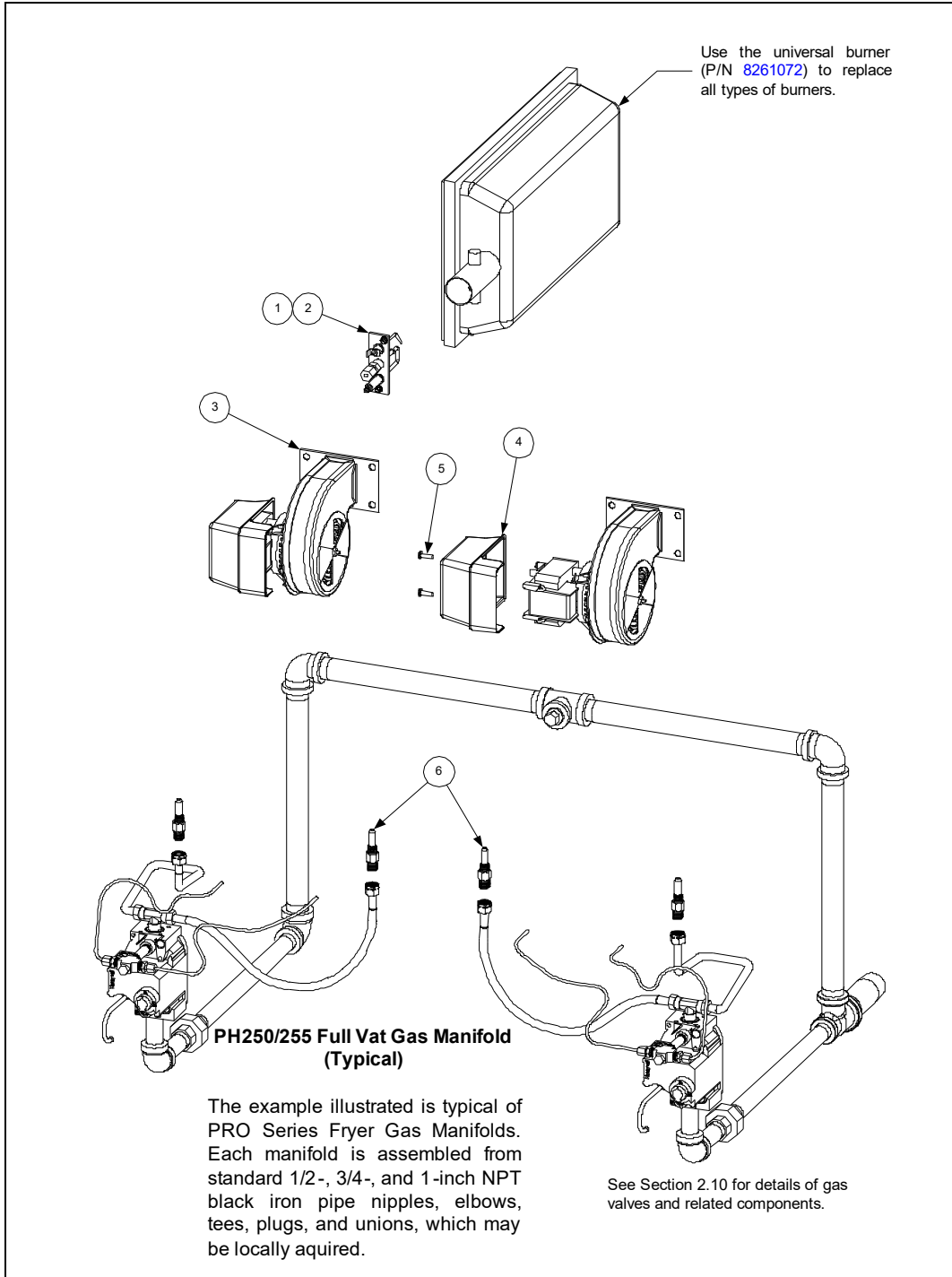

ITEM	PART #	COMPONENT
1		Ignitor (<i>includes gasket 8160059, which may be ordered separately</i>)
	8260981	Natural Gas (G20, G25)
	8260982	Propane (G30, G31)
	8261002	Manufactured Gas
2	8261371	Screw, #8 X 1/2-inch Hex Head (pkg. of 25)
3		Blower Assembly, Combustion Air (<i>includes harness and Items 4, and 5</i>)
	1062996SP	100V 50/60 Hz (Left)
	1062999SP	100V 50/60 Hz (Right)
	1062994SP	115V 50/60 Hz. (Left)
	1062997SP	115V 50/60 Hz (Right)
	1062995SP	208-240V 50/60 Hz (Left)
	1062998SP	208-240V 50/60 Hz (Right)
	1063000SP	230V 50/60 Hz CE (Left)
	1063001SP	230V 50/60 Hz CE (Right)
*	8263322	Gasket, Plenum Blower (<i>Used between blower and plenum</i>)
4	8160554	Cover, Blower Motor (<i>component of all blowers listed above</i>)
5	8090938	Screw, 10-32 X 5/8-inch Philips Truss Head (<i>secures Item 4 to Item 3</i>)
*	8068806SP	Harness Assembly, Blower Motor (<i>component of all blowers listed above</i>)
6		Orifice, Burner
	8121137	1.95 mm Propane/Butane (G30, G31) (0-4999 Ft, 0-1524 M) (CE)
	8101221	2.00 mm Propane/Butane (0-4999 Ft, 0-1524 M) (<i>Japan only</i>)
	8100386	2.10 mm Propane/Butane (0-4999 Ft, 0-1524 M)
	8100413	2.16 mm Propane/Butane (G30, G31) (5000-6999 Ft, 1525-2133 M)
	8121028	2.20 mm Propane/Butane (G30, G31) (7000-10,999 Ft, 2134-3352 M)
	8121134	3.10 mm Natural Gas (G20, G25) (0-4999 Ft, 0-1524 M) (<i>Japan only</i>)
	8100403	3.40 mm Natural Gas (G20, G25) (0-4999 Ft, 0-1524 M)
	8100437	3.60 mm Natural Gas (G20, G25) (5000-6999 Ft, 1525-2133 M)
	8121144	3.65 mm Natural Gas (G20, G25) (7000-8999 Ft, 2134-2743 M)
	8121145	3.70 mm Natural Gas (G20, G25) (9000-10,999 Ft, 2744-3352 M)
	8100642	5.95 mm Manufactured Gas (0-4999 Ft, 0-1524 M)
		CE Conversion Kits
*	8261196	Natural Gas (G20, G25) to Propane/Butane (G30, G31), Full-vat/Dual-vat
*	8261197	Propane/Butane (G30, G31) to Natural Gas (G20, G25), Full-vat/Dual-vat
		Non-CE Conversion Kits
*	8261145	Natural Gas (G20, G25) to Propane/Butane (G30, G31), Full-vat prior to 03/2020
*	8263616	Natural Gas (G20, G25) to Propane/Butane (G30, G31), Full-vat 03/2020 to current
*	8261146	Propane/Butane (G30, G31) to Natural Gas (G20, G25), Full-vat
*	8261147	Natural Gas (G20, G25) to Propane/Butane (G30, G31), Dual-vat prior to 03/2020
*	8263615	Natural Gas (G20, G25) to Propane/Butane (G30, G31), Dual-vat 3/2020 to current
*	8261148	Propane/Butane (G30, G31) to Natural Gas (G20, G25), Dual-vat
*	8072263	Switch, Air Pressure (<i>use 8072262 in units with 100VAC power supply</i>)

* Not illustrated.

2.9 Gas Valves and Associated Components

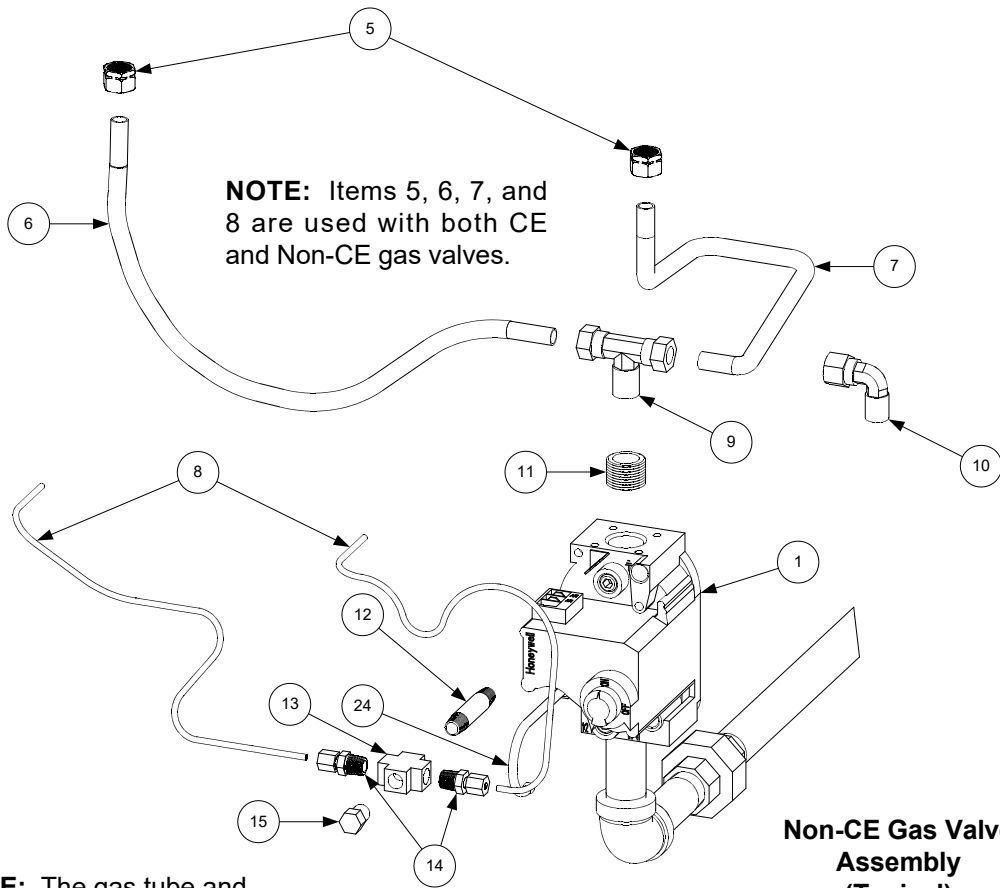

Non-CE Gas Valve Assembly (Typical)

NOTE: The gas tube and enrichment tube fittings are assembled in varying configurations depending upon the location of the valve and whether the associated frypot is a full- or dual-valve pot.

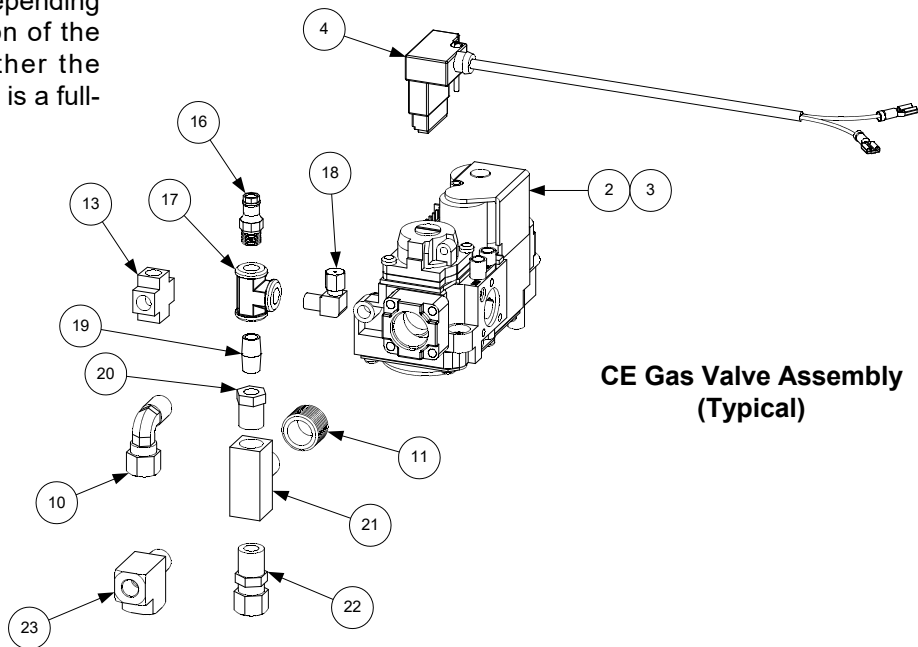

CE Gas Valve Assembly (Typical)

ITEM	PART #	COMPONENT
1		Valve, Non-CE Gas
	826-1122	Natural Gas (G20, G25)
	826-1123	Propane Gas (G30, G31)
2	810-1715	Valve, CE Gas (G20, G25, G30, G31)
3	810-1041	Accessory Kit <i>(contains parts to adapt Item 2 to specific fryer configuration)</i>
4	806-9678SP	Plug Assembly, CE Gas Valve
5	810-0494	Ferrule (Nut), Orifice
6	810-1355	Gas Line, 3/8-inch OD X 15-inch SS Flexible
7	810-1354	Gas Line, 3/8-inch OD X 12-inch SS Flexible
*	810-1353	Gas Line, 3/8-inch OD X 9-inch SS Flexible
8	811-0800	Tube, 1/8-inch OD X 12.5-inch Enrichment <i>(cut and form to fit)</i>
9	813-0301	Tee, 1/4-inch Male NPT to 3/8-inch Tube
10	813-0302	Elbow, 1/4-inch Male NPT to 3/8-inch Tube 90°
11	813-0304	Bushing, 1/2-inch NPT to 1/4-inch NPT Flush Reducing
12	813-0405	Nipple, 1/8-inch NPT X 2-inch
13	813-0378	Fitting, 1/8-inch NPT Cross
14	813-0340	Adapter, 1/8-inch NPT to 1/8-inch Tube
15	813-0154	Plug, 1/8-inch NPT Hex Head Pipe
16	810-1176	Tap, 1/8-inch NPT Pressure
17	813-0377	Tee, 1/8-inch NPT Female
18	813-0354	Elbow, 1/8-inch NPT X 1/8-inch Tube Compression
19	813-0016	Nipple, 1/8-inch NPT X Close
20	810-1006	Bushing, 1/4-inch NPT to 1/8-inch NPT Reducing
21	813-0495	Tee, 1/4-inch Male NPT to Female NPT
22	810-1025	Connector, 1/4-inch Male NPT to 3/8-inch Tube
23	810-1026	Tee, 1/4-inch Male NPT to Female NPT Street
24	810-0691	Tube, 1/8-inch Vent

* Not illustrated.

2.9.1 Gas Valve Wiring

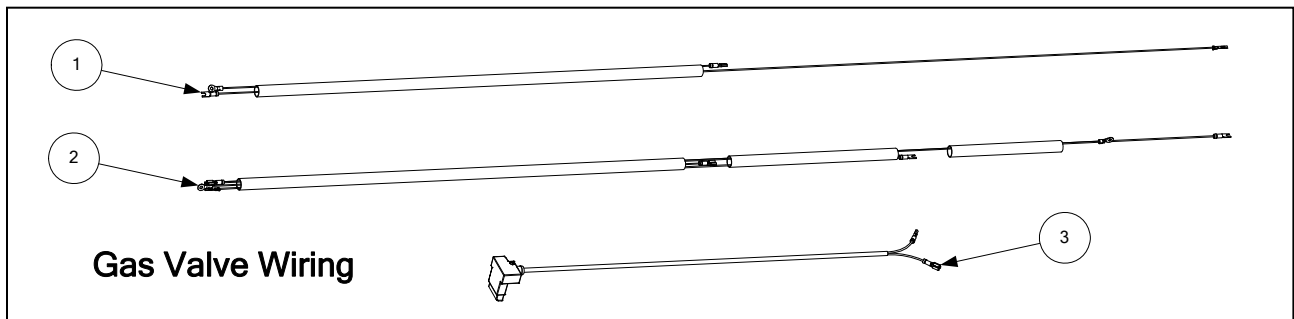

ITEM	PART #	COMPONENT
1	806-3941	Harness, Full Vat Gas Valve
2	806-3940	Harness, Dual Vat Gas Valve
3	806-9678SP	Plug Assembly, CE Gas Valve

2.10 Wiring Assemblies and Harnesses

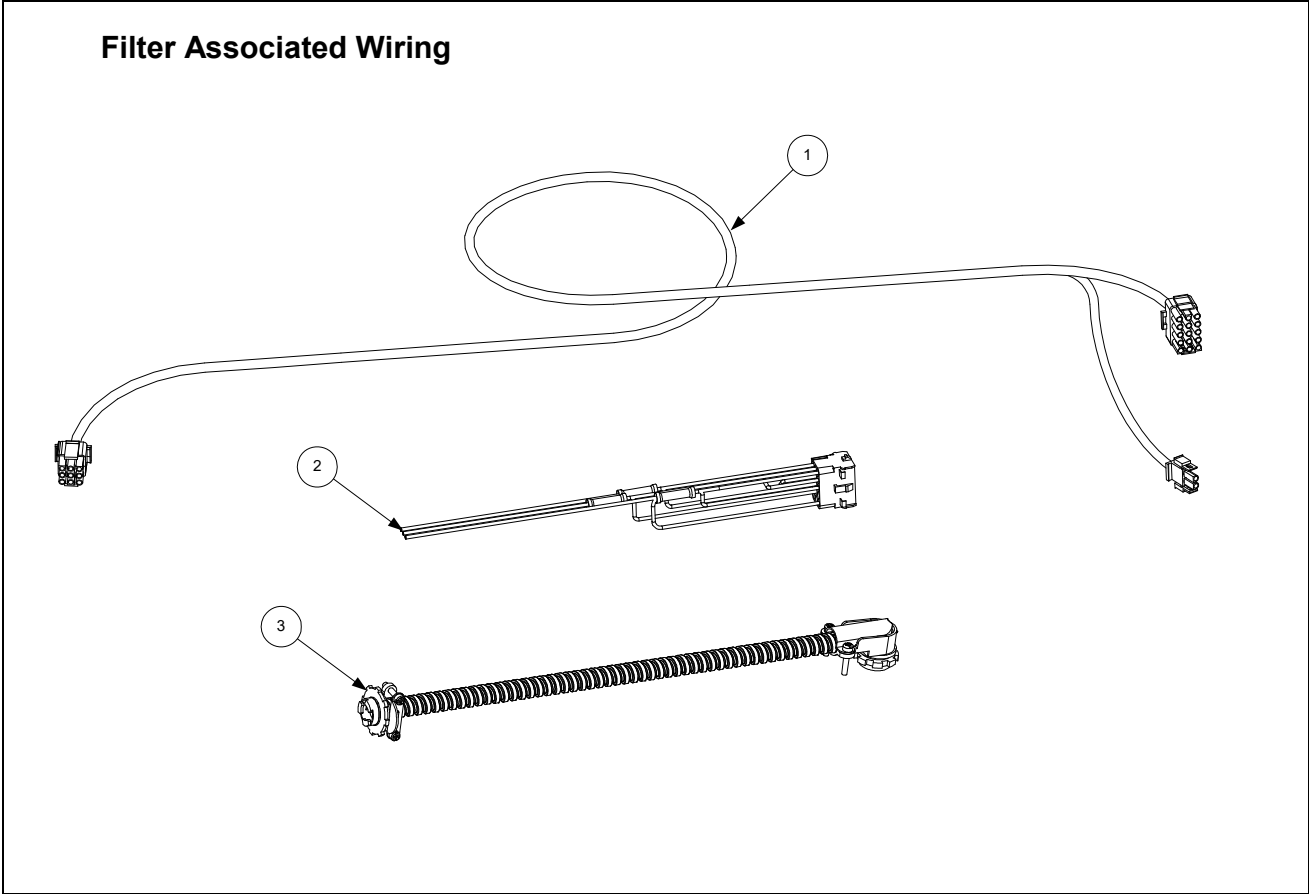

ITEM	PART #	COMPONENT
1	810-1062	Cable, Filter Box Lower 9-Pin Plug to 807-2000/2001 C2 Connector
*	807-2000	Cable, 810-1062 C2 Connector to Component Box (<i>units w/Basket Lift</i>)
2	807-2001	Cable, 810-1062 C2 Connector to Component Box (<i>units w/o Basket Lift</i>)
*	812-0362	Spaghetti Insulation, 36"
3	106-1020SP	Pump Motor to Transformer Box Wiring Assembly

* Not illustrated.

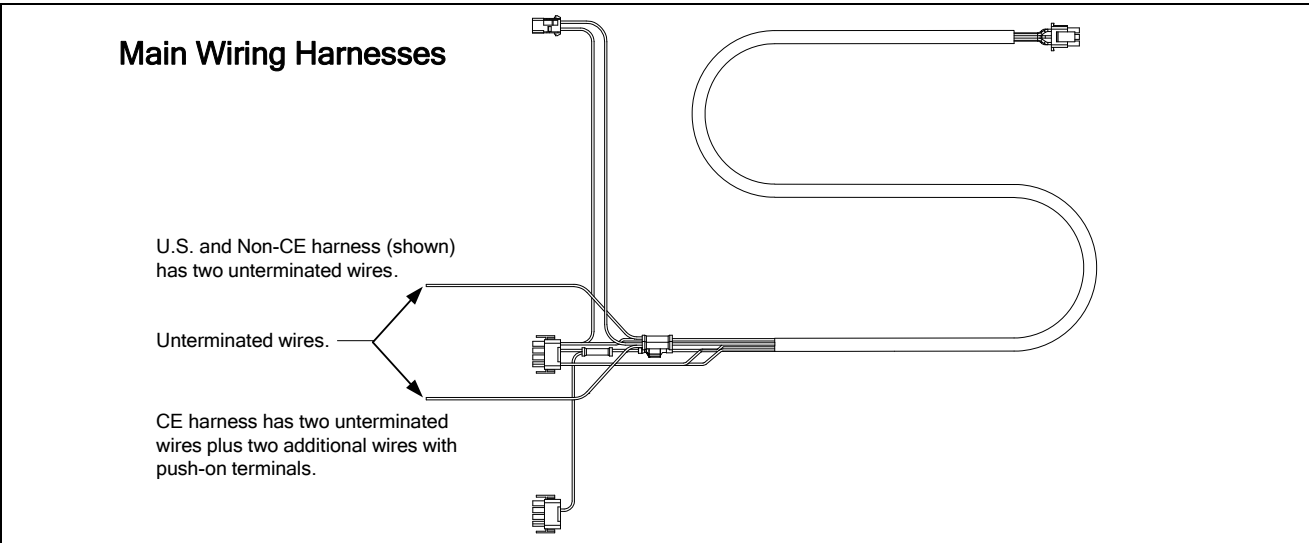

ITEM	PART #	COMPONENT
	807-1978	U.S. and Non-CE Export Main Wiring Harness
	807-2168	CE Main Wiring Harness
	807-4014	U.S. and Non-CE Export Main Wiring Harness (<i>Used on 3- or 5-Station Fryers</i>)

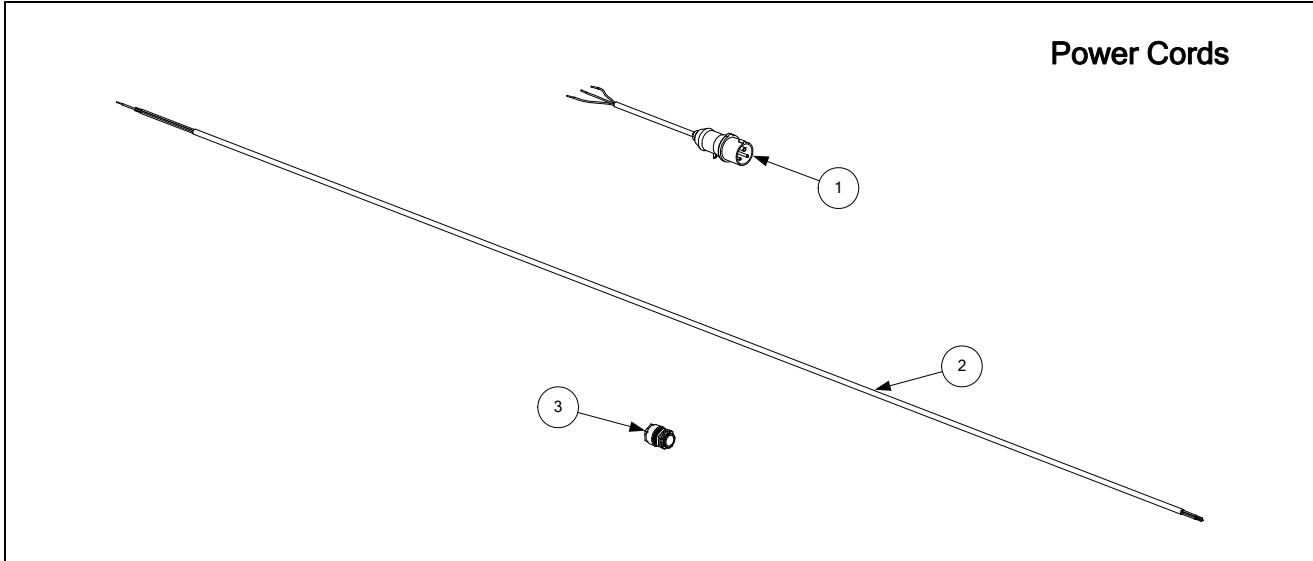

ITEM	PART #	COMPONENT
1	807-1696	Power Cord, CE
2	807-1685	Power Cable, 110-inch, 3-wire, 16-gauge, 450V, 18A
3	807-1560	Strain Relief
*	806-5332SP	Power Cord, 120V w/Grounding Plug (<i>w/Push-On Terminals and Clamp</i>)
*	807-0154	Power Cord, 120V w/Grounding Plug (<i>w/o Terminals or Clamp</i>)

2.11 Miscellaneous Connectors and Terminals

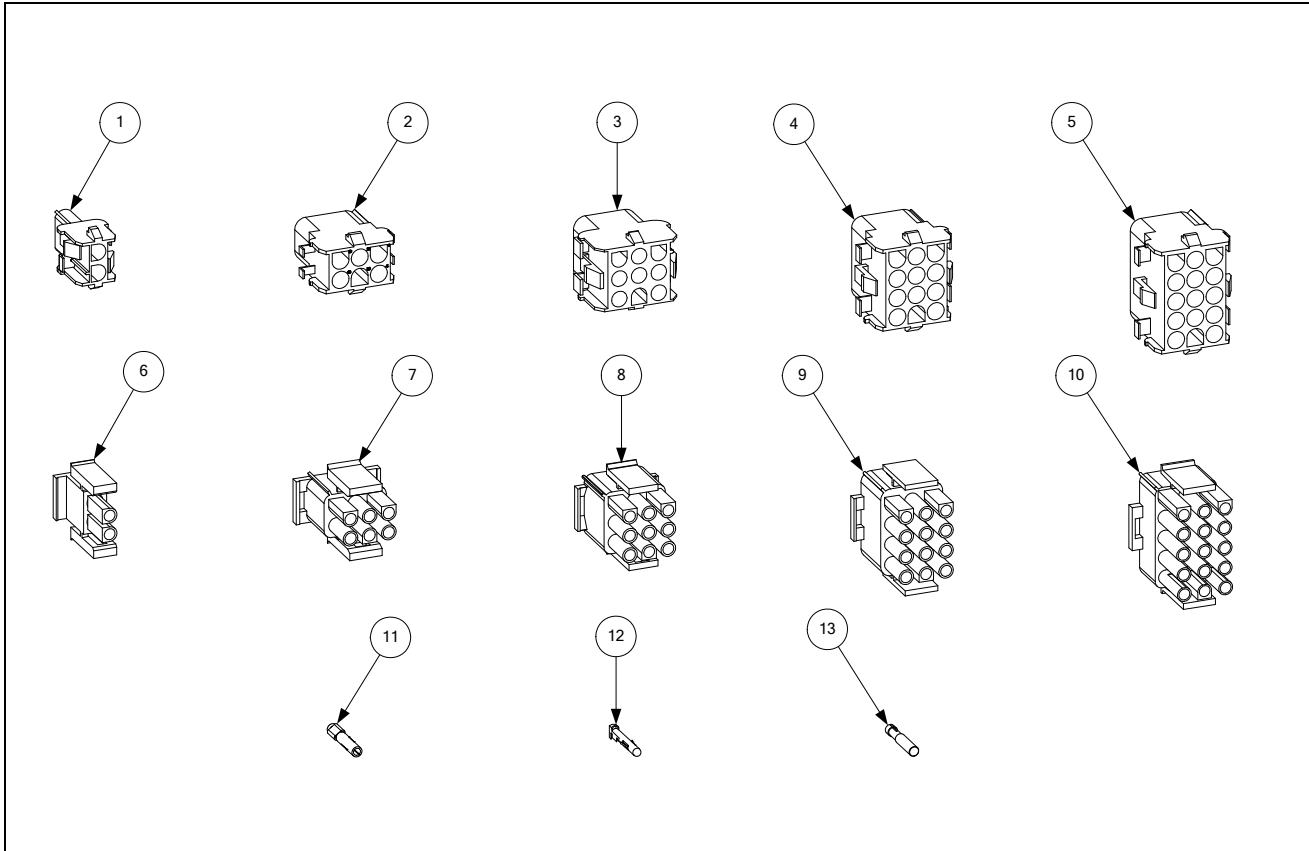

ITEM	PART #	COMPONENT
1	807-1068	2-Pin Female
2	807-0158	6-Pin Female
3	807-0156	9-Pin Female
4	807-0159	12-Pin Female
5	807-0875	15-Pin Female
6	807-1067	2-Pin Male
7	807-0157	6-Pin Male
8	807-0155	9-Pin Male
9	807-0160	12-Pin Male
10	807-0804	15-Pin Male
11	826-1341	Terminal, Female Split Pin (pkg. of 25)
12	826-1342	Terminal, Male Split Pin (pkg. of 25)
13	807-2518	Plug, Mate-N-Lock (Dummy Pin)

* Not illustrated.

PRO H50/55-SERIES GAS FRYERS

CHAPTER 3: SINGLE H50/55 UNIT UNIQUE PARTS LIST

3.1 Single H50/55 Filtration System Components

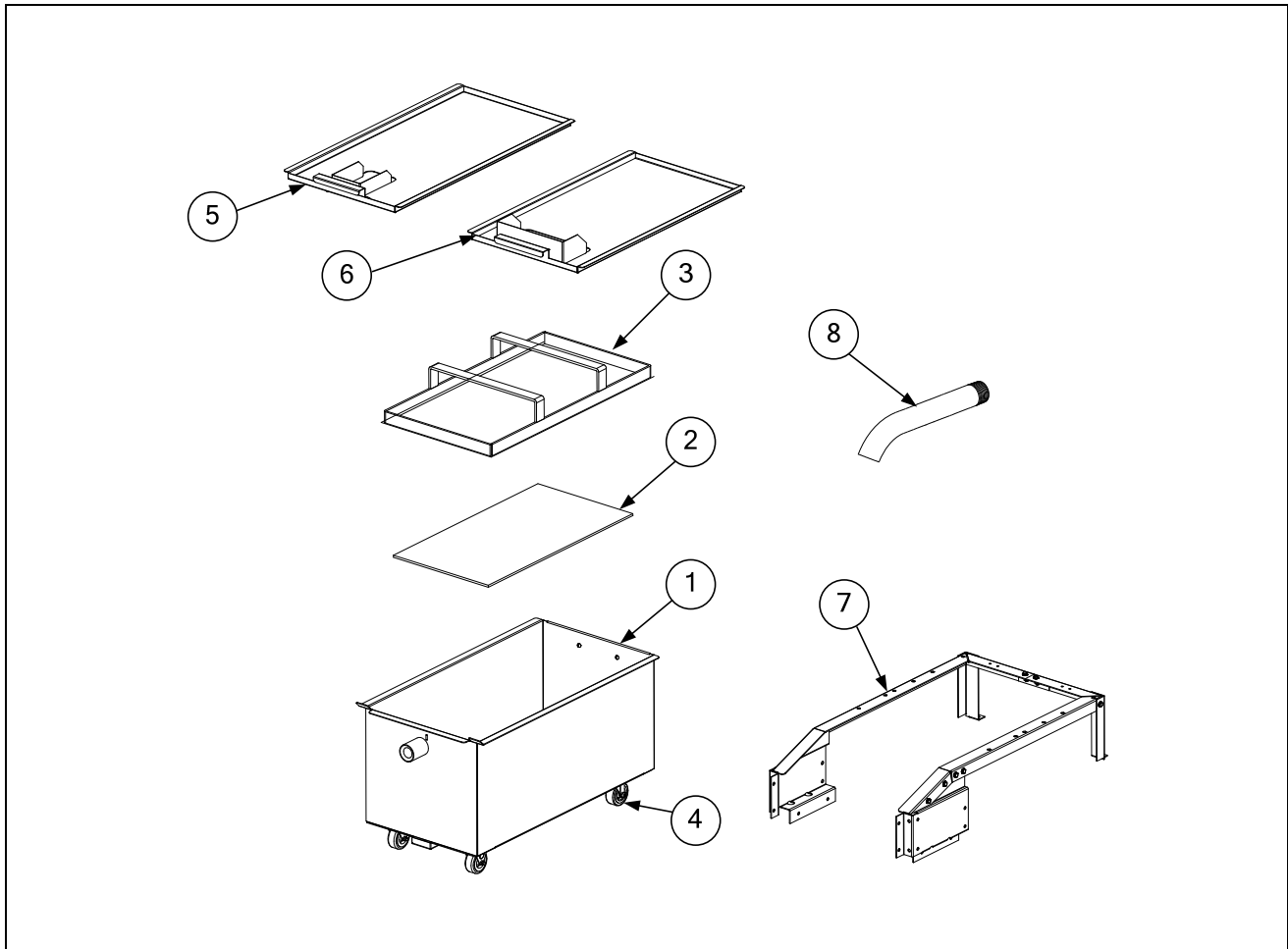

ITEM	PART #	COMPONENT
	8069255SP	Filter Pan Assembly, FootPrint Pro Filter <i>(includes Items 1, 2, 3, and 4)</i>
1	8232751	Pan Assembly, Filter
2	8103537	Screen, Sana Grid
3	8101406	Ring, Filter Paper Hold-Down Ring
4	8102805	Caster, 2" for Filter Pan
	8160596	O-Ring <i>(two required)</i>
5	8069446	Cover, Filter Pan, Full-vat
6	8232284	Cover, Filter Pan, Dual-vat
7	8065317	Rail Assembly, Single
8		Drain Valve Extension
	8121226SP	Full-Vat (1.25-inch)
	8121227	Dual-Vat (1-inch)

3.2 Single H50/55 Oil Return Components

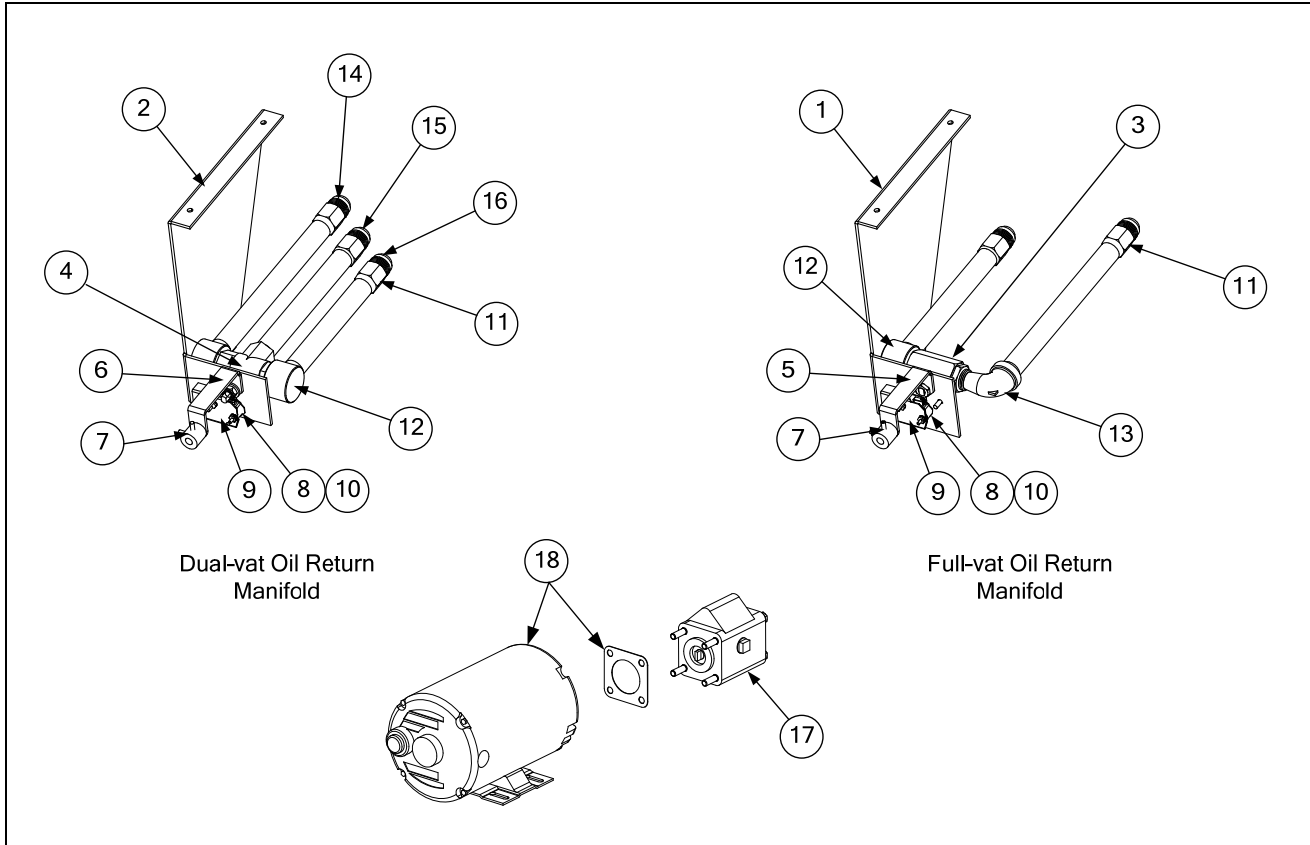

ITEM	PART #	COMPONENT
1	1081030	Mounting Bracket, Full-vat, Oil Return Valve
2	2204255	Mounting Bracket, Dual-vat, Oil Return Valve
*	2206187	Bracket, Valve (used to attach Item 3 to Item 1)
3	8102201	Valve, 1/2" Ball
4	8101003	Valve, 180° 3-way Ball
5	8237366	Handle, Full-vat, Oil Return
6	8237215	Handle, Dual-vat, Oil Return
7	8090157	Set Screw, 1/16 Socket, Oil Return Handle
8	8072104	Microswitch, Micro-roller and Lever
9	9022348	Cover, Safety Switch
10	8160220	Insulation, Switch
11	8101669	Adapter, Female, 7/8" OD x 1/2"
12	8130908	Adapter, 1/2" NPT, 90°
13	8130165	Elbow, Street, 1/2" x 1/2" NPT, 90° Black Metal
14	8130496	Nipple, 1/2" x 9.50 NPT, Black Metal
15	8130362	Nipple, 1/2" x 7.50 NPT, Black Metal
16	8130099	Nipple, 1/2" x 7.00 NPT, Black Metal
17	8263191	Filter Pump and Gasket Kit, 4 GPM, 2-piece (for gasket only, order P/N 8160093)
18		Motor and Gasket Kit, 50/60 Hz (for gasket only, order P/N 8160093)
	8261785	100V
	8261712	115V
	8261756	208V
	8261270	220-240V
	8261755	250V

* Not illustrated.

3.3 Single H50/55 Component Boxes

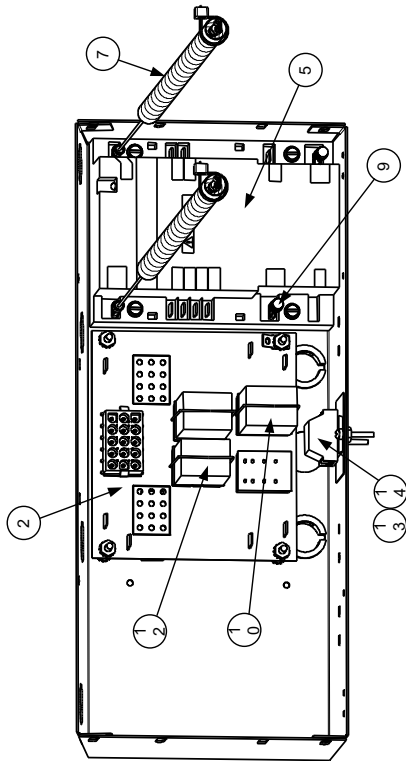

1066874 Domestic Full-vat Basket Lift SMT

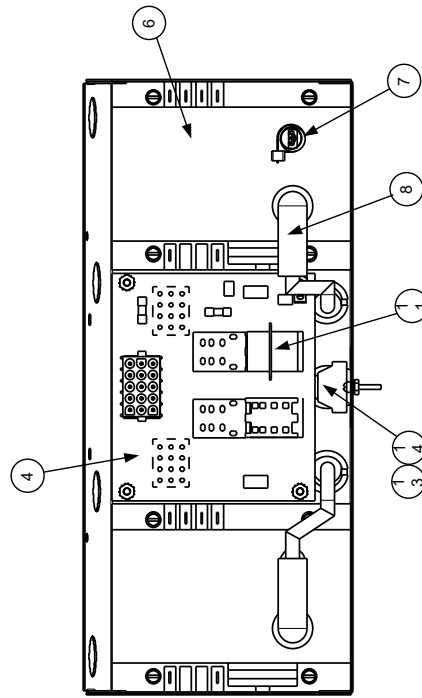

1066201 CE Dual-vat non-Basket Lift FAST

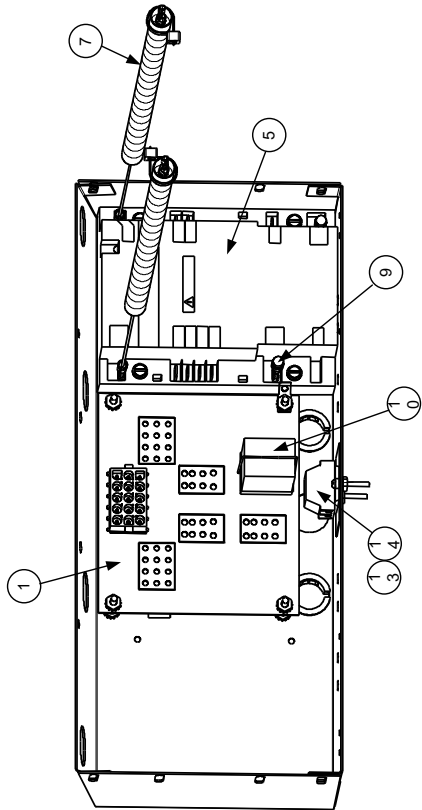

1066871 Domestic Full-vat non-Basket Lift SMT

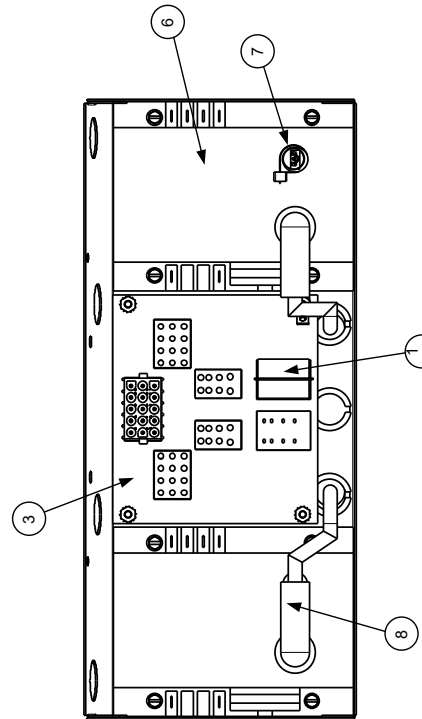

1066863 CE Full-vat Single non-Basket Lift SMT

ITEM	PART #	COMPONENT
1	1066708	Interface Board, SMT, Gas, non-Basket Lift, FV (<i>U.S., Canada, Mexico</i>)
2	8262264	Interface Board, SMT, Gas, with Basket Lift, FV (<i>U.S., Canada, Mexico</i>)
3	1066707	Interface Board, SMT, Gas, non-Basket Lift, FV (<i>Export</i>)
*	8080014	Interface Board, GIVEG Australia/NZ 04/2021 and after (use harness 807-6370)
4	1066711	Interface Board, SMT, Gas, non-Basket Lift, DV (<i>FAST</i>)
5	8073366	Ignition Module, Dual-spark, Full-vat (<i>U.S., Canada, HK, Mexico</i>)
*	8073365	Ignition Module, Single-spark, Dual-vat (<i>U.S., Canada, H.K., Mexico</i>)
*	8075949	Ignition Module, Single Spark Fenwal
6	8071006	Ignition Module, CE/non-CE Export (<i>except Australia, Canada, H.K., Mexico</i>)
*	8072971	Ignition Module (<i>Australia</i>) prior to 04/2021
*	8076382	Ignition Module, Australia/NZ 3 sec. FV Left, DV Fenwal 04/2021 to current
*	8076383	Ignition Module, Australia/NZ 4 sec. FV Right Fenwal 04/2021 to current
*	8075986	Harness, Fenwal Module FV
*	8075987	Harness, Fenwal Module DV
7	8066085	Wire, Ignitor
*	1088328	Wire Assy, Flame Sense (<i>used with 8076382 and 8076383</i>)
*	8073483	Cable, Ignition
8	8071878	Cable, 19" Ignition (<i>used with 8071006</i>)
9	8073484	Connector, Rajah
10	8070833	Relay, Latch/Valve
11	8073969	Relay, 5A (24VDC)
12	8070834	Relay, Basket Lift, 15A, 12V
13	8101164	Block, 1 Piece Screwless Terminal
14	8160217	Paper, CE Single Terminal, Black, Insulating

* Not illustrated.

NOTE 1: U.S., Canadian, Hong Kong, and Mexican units use two different modules depending upon the configuration of the frypot. Dual-vat units use two 8073365 Single-Spark Ignition Modules. Full-vat units use one 8073366 Dual-Spark Ignition Module. Also, in full-vat units, only one latch relay (Item 10) is used, located in the lower right socket.

NOTE 2: Basket Lift Relays (Item 12) are present only on units equipped with basket lifts.

3.4 Single H50/55 High-Limit Thermostat and Temperature Probe

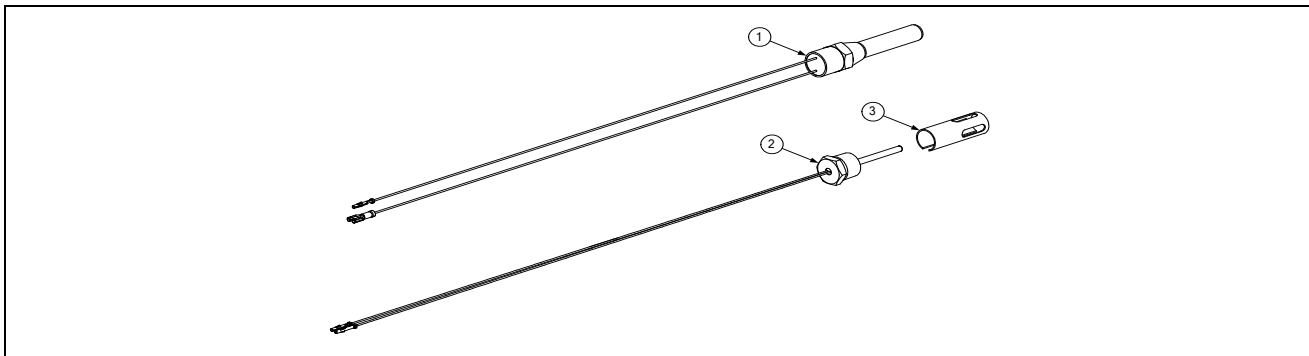

ITEM	PART #	COMPONENT
1	8261177	High Limit Thermostat - 425°F/218°C
2	8064206	Temperature Probe
*	1068457SP	Temperature Probe, FAST
*	8065046	Cable, FAST Probe
3	2100681	Probe Guard

* Not illustrated.

3.5 Single H50/55 Transformer Boxes

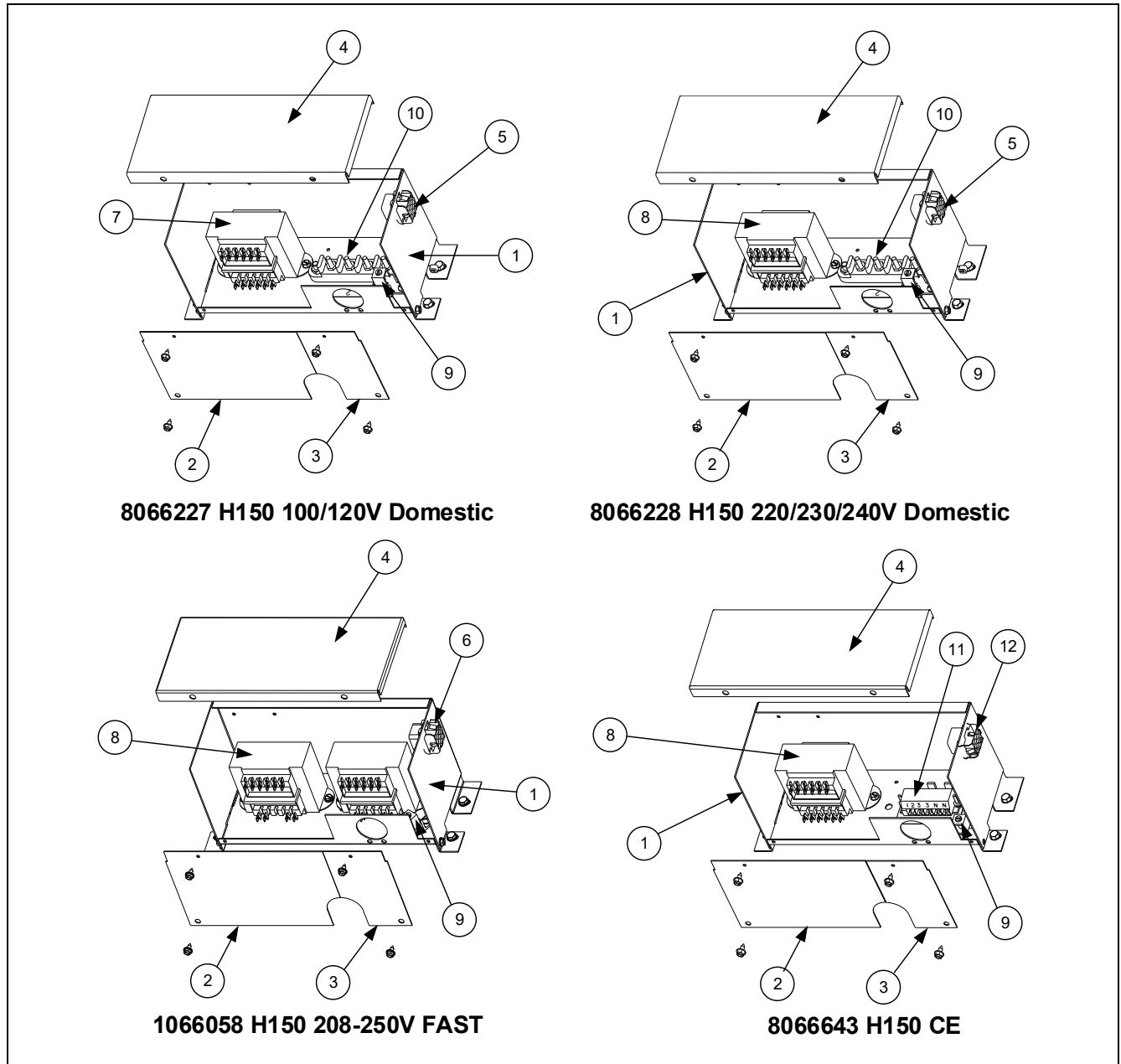

ITEM	PART #	COMPONENT
1	9002697	Transformer Box
2	9002703	Cover, Front, Large
3	9002709	Cover, Front, Small
4	9002708	Cover, Transformer Box
5	8066164	Harness Assembly, Domestic
6	1066056	Harness Assembly, FAST
7	8066637	Harness Assembly, CE
8	8072176	Transformer, V/F Dual Voltage 100/120V
9	8071999	Transformer, V/F Dual Voltage 208/222/230/240V
10	8070070	Terminal, Ground Lug
11	8071973	Terminal, Post
12	8101163	Terminal Block, Screwless

THIS PAGE INTENTIONALLY LEFT BLANK

Frymaster[®]

FRYMASTER
8700 LINE AVENUE, SHREVEPORT, LA 71106-6800

800-551-8633
318-865-1711
WWW.FRYMASTER.COM
EMAIL: FRYSERVICE@WELBILT.COM



Welbilt offers fully-integrated kitchen systems. Welbilt's portfolio of award-winning brands includes Cleveland™, Convotherm®, Crystal Tips®, Dean®, Delfield®, Fabristeel®, Frymaster®, Garland®, Inducs®, Koldtech®, Kolpak®, Lincoln®, McCann's™, Merco®, Merrychef®, Multiplex®, RDI®, SerVend™, SunFire®, U.S. Range™, and WMaxx™. Supported by service brands: FitKitchen®, kitchen systems; and KitchenConnect®, cloud-based open platform.

Bringing innovation to the table • welbilt.com

©2024 Frymaster LLC. except where explicitly stated otherwise. All rights reserved. Continuing product improvement may necessitate change of specifications without notice.

Part Number FRY_SP_8196083 01/2024