



**KSCF18G Cool Zone Series  
Gas Fryers  
Installation, Operation, Service, & Parts Manual**

**Please read all sections of this manual and retain for future reference.**

**PARTS LIST  
INCLUDED**

***Frymaster***<sup>®</sup>

**NON-CE &**



Frymaster, a member of the Commercial Food Equipment Service Association, recommends using CFESA Certified Technicians.

**24-Hour Service Hotline 1-800-551-8633**

[www.frymaster.com](http://www.frymaster.com)



**NOTICE**

This appliance is intended for professional use only and is to be operated by qualified personnel only. A Frymaster and Dean Factory Authorized Servicer (FAS) or other qualified professional should perform installation, maintenance, and repairs. Installation, maintenance, or repairs by unqualified personnel may void the manufacturer's warranty. See Chapter 1 of this manual for definitions of qualified personnel.

**NOTICE**

IF, DURING THE WARRANTY PERIOD, THE CUSTOMER USES A PART FOR THIS FRYMASTER DEAN EQUIPMENT OTHER THAN AN UNMODIFIED NEW OR RECYCLED PART PURCHASED DIRECTLY FROM FRYMASTER DEAN, OR ANY OF ITS AUTHORIZED SERVICE CENTERS, AND/OR THE PART BEING USED IS MODIFIED FROM ITS ORIGINAL CONFIGURATION, THIS WARRANTY WILL BE VOID. FURTHER, FRYMASTER DEAN AND ITS AFFILIATES WILL NOT BE LIABLE FOR ANY CLAIMS, DAMAGES OR EXPENSES INCURRED BY THE CUSTOMER WHICH ARISE DIRECTLY OR INDIRECTLY, IN WHOLE OR IN PART, DUE TO THE INSTALLATION OF ANY MODIFIED PART AND/OR PART RECEIVED FROM AN UNAUTHORIZED SERVICER.

**NOTICE**

This equipment must be installed in accordance with the appropriate national and local codes of the country and/or region in which the appliance is installed.

**NOTICE**

Drawings and photos used in this manual are intended to illustrate operational, cleaning and technical procedures and may not conform to onsite management operational procedures.

**NOTICE TO OWNERS OF UNITS EQUIPPED WITH COMPUTERS**

**U.S.**

This device complies with Part 15 of the FCC rules. Operation is subject to the following two conditions: 1) This device may not cause harmful interference, and 2) This device must accept any interference received, including interference that may cause undesired operation. While this device is a verified Class A device, it has been shown to meet Class B limits.

**Canada**

This digital apparatus does not exceed the Class A or B limits for radio noise emissions as set out by the ICES-003 standard of the Canadian Department of Communications.

Cet appareil numérique n'émet pas de bruits radioélectriques dépassant les limites de classe A et B prescrites dans la norme NMB-003 édictée par le Ministre des Communications du Canada.

** DANGER**

Improper installation, adjustment, maintenance or service, and unauthorized alterations or modifications can cause property damage, injury, or death. Read the installation, operating and service instructions thoroughly before installing or servicing this equipment. Only qualified service personnel may convert this appliance to use a gas other than that for which it was originally configured. See Chapter 1 of this manual for definition of qualified service personnel.

**⚠ DANGER**

Adequate means must be provided to limit the movement of this appliance without depending upon the gas line connection. Single fryers equipped with legs must be stabilized by installing anchor straps. All fryers equipped with casters must be stabilized by installing restraining chains. If a flexible gas line is used, an additional restraining cable must be connected at all times when the fryer is in use.

**⚠ DANGER**

The front ledge of the fryer is not a step. Do not stand on the fryer. Serious injury can result from slips or contact with the hot oil.

**⚠ DANGER**

Do not store or use gasoline or other flammable vapors and liquids in the vicinity of this or any other appliance.

**⚠ DANGER**

Instructions to be followed in the event the operator smells gas or otherwise detects a gas leak must be posted in a prominent location. This information can be obtained from the local gas company or gas supplier.

**⚠ DANGER**

The crumb tray in fryers equipped with a filter system must be emptied into a fireproof container at the end of frying operations each day. Some food particles can spontaneously combust if left soaking in certain shortening material. Additional information can be obtained in the filtration manual included with the system.

**⚠ WARNING**

No structural material on the fryer should be altered or removed to accommodate placement of the fryer under a hood. Questions? Call the Dean Service Hotline at 1-800-551-8633.

**⚠ WARNING**

Do not bang fry baskets or other utensils on the fryer's joiner strip. The strip is present to seal the joint between the frypot. Banging fry baskets on the strip to dislodge shortening will distort the strip, adversely affecting its fit. It is designed for a tight fit and should only be removed for cleaning.

**IMPORTANT**

Safe and satisfactory operation of Dean equipment depends upon its proper installation. Installation **MUST** conform with local codes, or in the absence of local codes, to European Community (CE) Standards.

# KSCF18G Cool Zone Gas Fryers

## INSTALLATION & OPERATION MANUAL

### TABLE OF CONTENTS

	Page #
1. INTRODUCTION.....	1-1
2. IMPORTANT INFORMATION.....	2-1
3. INSTALLATION INSTRUCTIONS.....	3-1
4. DAILY OPERATION.....	4-1
5. FILTRATION.....	5-1
6. PREVENTATIVE MAINTENANCE.....	6-1
7. TROUBLESHOOTING.....	7-1
8. PARTS LIST: DOUBLE AND TRIPLE UNITS (218/318).....	8-1
9. PARTS LIST: SINGLE UNITS (118).....	9-1

# KSCF18G COOL ZONE SERIES GAS FRYERS

## CHAPTER 1: INTRODUCTION

---

### 1.1 Applicability and Validity

The KSCF18G Cool Zone Series gas model family has been approved by the European Union (EU) for sale and installation in the following EU countries: AT, BE, KE, KD, ES, FI, FR, GB, IE, IT, LU, NL, NO, PT and SE.

This manual is applicable to and valid for all KSCF18G gas units sold in English-speaking countries, including those in the European Union. Where conflicts exist between instructions and information in this manual and local or national codes of the country in which the equipment is installed, installation and operation shall comply with those codes.

This appliance is only for professional use and shall be used by qualified personnel as defined in Section 1.7.

### 1.2 After Purchase

In order to improve service, have the following chart filled in by the Frymaster Authorized Servicer who installed this equipment.

Authorized Servicer Technician/FAS	_____
Address	_____
Telephone/Fax	_____
Model Number	_____
Serial Number	_____
Gas Type	_____

### 1.3 Ordering Parts

Customers may order parts directly from their local factory authorized servicer(FAS). If the telephone number of your FAS is not listed above, call the Frymaster Service Hotline telephone number, 1-800-551-8633. A list of Frymaster Factory Authorized Servicers (FAS's) is located on the Frymaster website at [www.frymaster.com](http://www.frymaster.com).

To speed up your order, provide the model number, serial number, gas type, part needed, item part number (if known), and quantity needed.

# KSCF18G COOL ZONE SERIES GAS FRYERS

## CHAPTER 1: INTRODUCTION

---

### 1.4 Service Information

Call the Frymaster Service Hotline, 1-800-551-8633, for the location of your nearest factory authorized servicer (FAS). To assist you more efficiently, always provide the service technician with the model number, gas type, serial number, and the nature of the problem.

### 1.5 Computer Information

This equipment has been tested and found to comply with the limits for a Class A digital device, pursuant to Part 15 of the FCC rules. While this device is a verified Class A device, it has been shown to meet the Class B limits. These limits are designed to provide reasonable protection against harmful interference when the equipment is operated in a commercial environment. This equipment generates, uses and can radiate radio frequency energy and, if not installed and used in accordance with the instruction manual, may cause harmful interference to radio communications. Operation of the equipment in a residential area is likely to cause harmful interference in which case the user will be required to correct the interference at his own expense.

The user is cautioned that any changes or modifications not expressly approved by the party responsible for compliance could void the user's authority to operate the equipment.

If necessary, the user should consult the dealer or an experienced radio and television technician for additional suggestions.

The user may find the following booklet prepared by the Federal Communications Commission helpful: "How to Identify and Resolve Radio-TV Interference Problems". This booklet is available from the U.S. Government Printing Office, Washington, DC 20402, Stock No. 004-000-00345-4.

### 1.6 Safety Information

Before attempting to operate your unit, read the instructions in this manual thoroughly.

Throughout this manual, you will find notations enclosed in double-bordered boxes similar to the ones below.

#### CAUTION

**CAUTION** boxes contain information about actions or conditions that *may cause or result in a malfunction of your system.*

#### WARNING

**WARNING** boxes contain information about actions or conditions that *may cause or result in damage to your system,* and which may cause your system to malfunction.

**KSCF18G COOL ZONE SERIES GAS FRYERS**  
**CHAPTER 1: INTRODUCTION**

---

## 1.6 Safety Information (cont.)



**DANGER** boxes contain information about actions or conditions, which *may cause or result in injury to personnel*, may cause damage to your system, and/or cause your system to malfunction.

## 1.7 Service Personnel

- A. Qualified and/or Authorized Operating Personnel:** Qualified/authorized operating personnel are those who have carefully read the information in this manual and have familiarized themselves with the equipment functions, or have had previous experience with the operation of equipment covered in this manual.
- B. Qualified Installation Personnel:** Qualified/authorized personnel are those who have carefully read the information in this manual and have familiarized themselves with the equipment functions, or who have had previous experience with the operation of the equipment covered in this manual.

**Qualified Service Personnel:** Qualified service personnel are those who are familiar with Frymaster equipment and are authorized by Frymaster to perform service on Frymaster equipment. All authorized service personnel are required to be equipped with a complete set of service parts manuals and stock a minimum amount of parts for Frymaster equipment. A list of Frymaster Factory Authorized Servicer (FAS's) is located on the Frymaster website at [www.frymaster.com](http://www.frymaster.com). *Failure to use qualified service personnel will void the Frymaster warranty on your equipment.*

# KSCF18G COOL ZONE SERIES GAS FRYERS

## CHAPTER 2: IMPORTANT INFORMATION

---

### 2.1 Receiving and Unpacking Equipment

- A. Check that the container is upright. Use an outward prying motion - ***no hammering*** - to remove the carton. Unpack the fryer carefully and remove all accessories from the carton. Do not discard or misplace these, as they will be needed.
- B. After unpacking, immediately check the equipment for visible signs of shipping damage. If damage has occurred, contact the carrier and file the appropriate freight claims. Do not contact the factory. Shipping damage responsibility is between the carrier and the dealer.

#### **If your equipment arrives damaged:**

1. File claim for damages immediately, regardless of extent of damage.
2. Visible loss or damage: Be sure this is noted on the freight bill or express receipt and is signed by the person making the delivery.
3. Concealed loss or damage: If damage is unnoticed until equipment is unpacked, notify freight company or carrier immediately, and file a concealed damage claim. This should be done within five (5) days of date of delivery. Be sure to retain container for inspection.

**NOTE:** Frymaster does not assume responsibility for damage or loss incurred in transit.

- C. **Frying systems with built-in filtration:** Take off the filter support brace and remove the filter pan from the cabinet.
- D. Remove all plastic skin from sides, front, and doors of the fryer(s). Failure to do this prior to initial fryer operation will make it very difficult to remove later.

### 2.2 General

Upon arrival, inspect the fryer carefully for visible or concealed damage. (See *Receiving and Unpacking Equipment*, Section 2.1.)

The Frymaster KSCF18G Cool Zone Series Fryers are energy-efficient, gas-fired units, design-certified by the International Approval Services (AGA/CGA), Gaz de France, and NSF International and manufactured to their basic performance and application specifications.

All units are shipped completely assembled with accessories packed inside the frypots. All units are adjusted, tested, and inspected at the factory before shipment. Sizes, weights, and input rates of all models are listed in this manual.

# KSCF18G COOL ZONE SERIES GAS FRYERS

## CHAPTER 2: IMPORTANT INFORMATION

---

### 2.3 Principles of Operation

The incoming gas flows through orifices and is mixed with air in the burners to create the correct ratio for proper combustion. The mixture is ignited at the front end of each heat tube by the pilot light. Internal diffusers slow the flame as it goes through the burner tube. This slower and more turbulent flame gives much better heat transfer to the walls of the tubes, thereby heating the oil more efficiently.

### 2.4 Rating Plate

This is attached to the inside of the front door panel. Information provided includes the model and serial number of the fryer, BTU/hr (kW/hr) input of the burners, outlet gas pressure in inches W.C. (mbars), and whether the unit has natural (G20/25) or propane (G31) gas orifices.

### 2.5 Pre-Installation

 **DANGER**

**This appliance is equipped with a three-prong (grounding) plug for your protection against electrical shock and must be plugged directly into a properly grounded three-prong receptacle. Do not cut, remove, or otherwise bypass the grounding prong on this plug.**

A. **General:** Only licensed personnel should install any gas-fired equipment.

1. A manual gas shut-off valve must be installed in the gas supply line ahead of the fryers for safety and ease of future service.
2. The Frymaster KSCF18G gas fryers require 120 volts (AC) 60-cycle electrical service for non-CE installation (U.S./Canada/Mexico) and 230 volts (AC) 50-cycle electrical service for CE/International installations. Fryers are equipped with a 16-3 SJT grounded flexible power cord for a direct connection to the power supply. Amperage draw for each unit depends on the accessories supplied with the unit. See detailed instructions packaged with the fryer line-up.

 **DANGER**

**No structural material on the fryer should be altered or removed to accommodate placement of the fryer under a hood. Questions? Call the Frymaster Service Hotline at 1-800-551-8633.**

**KSCF18G COOL ZONE SERIES GAS FRYERS  
CHAPTER 2: IMPORTANT INFORMATION**

---

## 2.5 Pre-Installation (cont.)



**This appliance must be installed with sufficient ventilation to prevent the occurrence of unacceptable concentrations of substances harmful to the health of personnel in the room in which it is installed.**

**B. Clearances:** The fryer area must be free of all combustibles. This unit is design-certified for the following installations:

1. Commercial installation only; **not** for household use.
2. Non-combustible floor installation equipped with factory-supplied 6-inch (15-cm) adjustable legs or 5-inch (13-cm) casters;
3. Combustible construction with a minimum clearance of 6-inches (15-cm) side and 6-inches (15-cm) rear, and equipped with factory-supplied 6-inch (15-cm) adjustable legs or 5-inch (13-cm) casters.

### C. Installation Standards

<p><b>1. U.S. installations must meet:</b></p> <p>American National Standard Institute ANSI Z83.11 American Gas Association 8501 E. Pleasant Valley Road Cleveland, OH 44131</p> <p>National Electrical Code ANSI/NFPA #70 American National Standard Institute 1430 Broadway New York, NY 10018</p> <p>NFPA Standards #96 and #211 National Fire Protection Association 470 Atlantic Avenue Boston, MA 02110</p>	<p><b>2. Canadian installations must meet:</b></p> <p>CAN 1-B149 Installation Codes Canadian Gas Association 55 Scarsdale Road Don Mills, ONT, M3B 2R3</p> <p>Canadian Electric Code c22.1, part 1 Canadian Standards Association 178 Rexdale Blvd. Rexdale, ONT, M9W 1R3</p> <p><b>3. Australian installations must meet:</b></p> <p>AS5601/AG601 Installation Codes <b>Standards Australia International</b> 25 Raglan Street South Melbourne, VIC 3205</p>
---	---

- 4. CE/EXPORT STANDARDS:** Fryer installation must conform with local codes, or in the absence of local codes, to the appropriate national or European Community (CE) standards.

**KSCF18G COOL ZONE SERIES GAS FRYERS**  
**CHAPTER 2: IMPORTANT INFORMATION**

---

## **2.6 Air Supply and Ventilation**



**Do not connect this appliance to the gas supply before reviewing each step in this section.**

- A. Keep the area around the fryer clear to prevent obstruction of combustion and ventilation airflow and to allow for service and maintenance. Always adhere to the following:
1. Do not connect this fryer to an exhaust duct.
  2. Follow installation and adjustment procedure to ensure adequate airflow to the fryer system.
  3. A heavy-duty, commercial fryer's combustion wastes must vent to the outside of the building. A deep-fat fryer must be installed under a powered exhaust hood, or an exhaust fan must be provided in the wall above the unit. Exhaust gas temperatures are approximately 800-1000°F (427-538°C). Check air movement during installation. Strong exhaust fans in the exhaust hood or in the overall air conditioning system can produce slight air drafts in the room and cause erratic burner flames or improper fryer operation.
  4. Do not place the fryer's flue outlet directly into the plenum of the hood, as it will affect the gas combustion of the fryer.
  5. **Never** use the interior of the fryer cabinet for storage or store items on shelving over or behind the fryer. Exhaust temperatures can exceed 800°F (427°C) and may damage or melt items stored in or near the fryer.
  6. Adequate distance must be maintained from the flue outlet of the fryer(s) to the lower edge of the filter bank. Per NFPA Standards No. 96, a minimum of 18-inches (45-cm) should be maintained between the flue(s) and the lower edge of the exhaust hood filter.
  7. Filters and drip troughs should be part of an industrial hood, but consult local codes before constructing and installing any hood. The duct system, the exhaust hood, and the filter bank must be cleaned on a regular basis and kept free of grease.

## **2.7 Equipment Installed at High Altitudes**

- A. The fryer input rating [BTU/hr (kW/hr)] is for elevations up to 2,000 feet (610 m). For elevations above 2,000 feet (610 m), the rating should be reduced 4% for each additional 1,000 feet (305 m) above sea level.
- B. The correct orifices are installed at the factory if operating altitude is known at time of the customer's order.

**KSCF18G COOL ZONE SERIES GAS FRYERS  
CHAPTER 2: IMPORTANT INFORMATION**

---

## 2.8 Conversion of Units

**Pressure:**

1 mbar = 10.2 mm water column (mm W.C.) = 0.4 Inch W.C.

20 mbar = 204 mm W.C. = 8 Inch W.C.

1 inch W.C. = 25.4 mm W.C. = 2.5 mbar

**Heat Input:**

1 kW = 3410 BTU/hr

100 BTU/hr = 0.0293 kW

**Temperature:**

0° Celsius = 32° Fahrenheit

Temperature in degrees Celsius = (Temperature in degrees Fahrenheit (F) – 32) x 0.555

100° Celsius = (212° Fahrenheit – 32) x 0.555

## 2.9 Restraining the Fryer

 **DANGER**

**No structural material on the fryer should be altered or removed to accommodate placement of the fryer under a hood. Questions? Call the Frymaster Dean Service Hotline at 1-800-551-8633.**

1. Once the fryer has been positioned at the frying station, use a carpenter's level placed across the top of the frypot to verify that the unit is level, both side-to-side and front-to-back.
  - To level fryers equipped with legs, the bottom of the legs can be screwed out up to one inch for leveling. Legs should also be adjusted so that the fryer(s) are at the proper height in the frying station.
  - For fryers equipped with casters, there are no built-in leveling devices. The floor where the fryers are installed must be level.
2. With the fryer level in its final position, install the restraints provided with the unit to limit its movement so that it does not depend on or transmit stress to the electrical conduits/connections or the gas supply line. Install the restraints in accordance with the provided instructions (see illustration on the next page). If disconnected for service or other reasons, the restraints must be reconnected before the fryer is used.

 **DANGER**

**Adequate means must be provided to limit the movement of this appliance without depending on or transmitting stress to the electrical conduit. A restraint kit is**

**KSCF18G COOL ZONE SERIES GAS FRYERS**  
**CHAPTER 2: IMPORTANT INFORMATION**

provided with the fryer. If the restraint kit is missing contact your local Frymaster Factory Authorized Servicer (FAS) for part number 826-0900.

### 2.9 Restraining the Fryer (cont.)

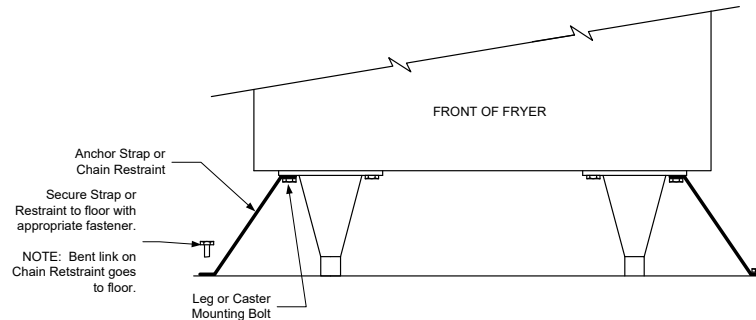

**NOTE:** If you need to relocate a fryer installed with legs, remove all weight from each leg before moving. If a leg is damaged, contact your service agent for immediate repair or replacement.

**⚠ DANGER**

**Hot oil can cause severe burns. Avoid contact. Under all circumstances, oil must be removed from the fryer before attempting to move it to avoid oil spills, falls and severe burns. This fryer may tip and cause personal injury if not secured in a stationary position.**

**⚠ DANGER**

**Do not attach an apron drain board to a single unit. The appliance may become unstable, tip over, and cause injury. The appliance area must be free and clear of combustible material at all times.**

### 3.1 Installing the Fryer

Qualified, licensed, authorized installation or service personnel only (as defined in Section 1.7) should perform the following:

1. Installation and service of Frymaster equipment;
2. Conversion of this appliance from one gas type to another.

Failure to use qualified, licensed, and/or authorized installation or service personnel to install, convert to another gas type, or otherwise service this equipment will void the Frymaster warranty and may result in damage to the equipment or injury to personnel.

Where conflicts exist between instructions and information in this manual and local code or national codes and regulations, installation and operation shall comply with the codes or regulations in force in the country in which the equipment is installed.

- A. **Initial Installation:** If installed with legs, do not push against any unit edges to adjust its position. Use a pallet or lift jack to lift it slightly and place it where it is to be installed.
- B. **Relocating the Fryer:** If relocating a fryer installed with legs, remove all weight from each leg before moving.

**NOTE:** If a leg becomes damaged during movement, contact your service agent for immediate repair or replacement.



Building codes prohibit a fryer with an open tank of oil being installed beside an open flame of any type, including those of broilers and ranges.

### 3.2 Leg and Caster Installation



Frymaster fryers equipped with legs are for permanent installations. Fryers fitted with legs must be lifted during movement to avoid damage and possible bodily injury. For a moveable or portable installation, optional equipment casters must be used. Questions? Call 1-800-551-8633

#### A. General

1. Because neither legs nor rigid rear casters are secure for long transit, install them near the area of use. This unit cannot be curb mounted and must be equipped with the legs and rear rigid casters provided.

**KSCF18G COOL ZONE SERIES GAS FRYERS  
CHAPTER 3: INSTALLATION INSTRUCTIONS**

---

### **3.2 Leg and Caster Installation (cont.)**

2. When positioning the fryer, gently lower it into position to prevent undue strain to the legs and internal mounting hardware. If possible, use a pallet or lift jack to lift and position the fryer. Tilting the fryer may damage the legs.
3. The rigid casters must be installed on the fryer rear channel assembly only.

#### **B. Installation**

1. Remove unit from pallet.
2. Carefully raise unit with forklift, pallet jack, or other steady means.
3. Place one lock washer on each hex head screw.
4. Insert hex head screws with lock washers [1/4-20 threads by 3/4" (19 mm) long] through bolt holes of leg mounting plates and mount to the front channel. Mount rigid casters to the rear channel following the same procedure. Locknuts have been attached to the topside of the base mounting plates at the factory to capture hex head screws as they are screwed in.
5. Tighten the bolts to 50 in-lbf (5.65 joules) minimum torque.
6. After legs and rear rigid casters are installed, proceed to Step 3.3, *Leveling the Fryer*, to ensure the fryer is level before use.



**WARNING**

**For caster retrofit, the unit must be at room temperature and drained of shortening before installing the casters.**

### **3.3 Leveling the Fryer**

- A. Place a level across the top of the fryer and level the unit front-to-back. If the fryer is uneven side-to-side, a platform or other surface adjustment is needed; there is no side-to-side level adjustments on a fryer equipped with caster/leg combinations (If a fryer is equipped with legs only, side to side level adjustments can be made. If a fryer is equipped with casters only, no level adjustments to the fryer can be made.). If the fryer is not level, the unit may not function efficiently, the oil may not drain properly for filtering, and it may not match adjacent units in a multi-fryer battery.

# KSCF18G COOL ZONE SERIES GAS FRYERS

## CHAPTER 3: INSTALLATION INSTRUCTIONS

### 3.3 Leveling the Fryer (cont.)

- **Legs (Only)**

1. Adjust leg height with an adjustable or  $1\frac{1}{16}$ -inch (27-mm) open-end wrench by turning the hex bullet on the bottom of the leg.
2. The hex bullet is for minor leg height adjustment only. Do not adjust more than 1 inch (25 mm).
3. When leveling the unit, the leg body should be held firmly to keep the leg from bending or rotating while turning the hex bullet foot to the required height.

- **Rigid Casters (Only)**

1. Install rigid casters on the fryer rear channel only. Legs must be installed on the front channel.
2. There are no level-adjustments for the rigid casters.

B. If the floor is uneven or has a decided slope, place the fryer on a smooth platform.

C. If the fryer is moved, re-level the fryer following the instructions given in Steps 3.3, A-C.

#### D. Installing Optional Swivel Casters

1. Install non-locking casters only at the rear of the unit.
2. Locking casters must be installed at the front of the unit. Locking casters allow the fryer to be "locked" in position for safe operations.
3. Follow the same instructions for leg installations as given above in Steps 3.2, B1-B5.

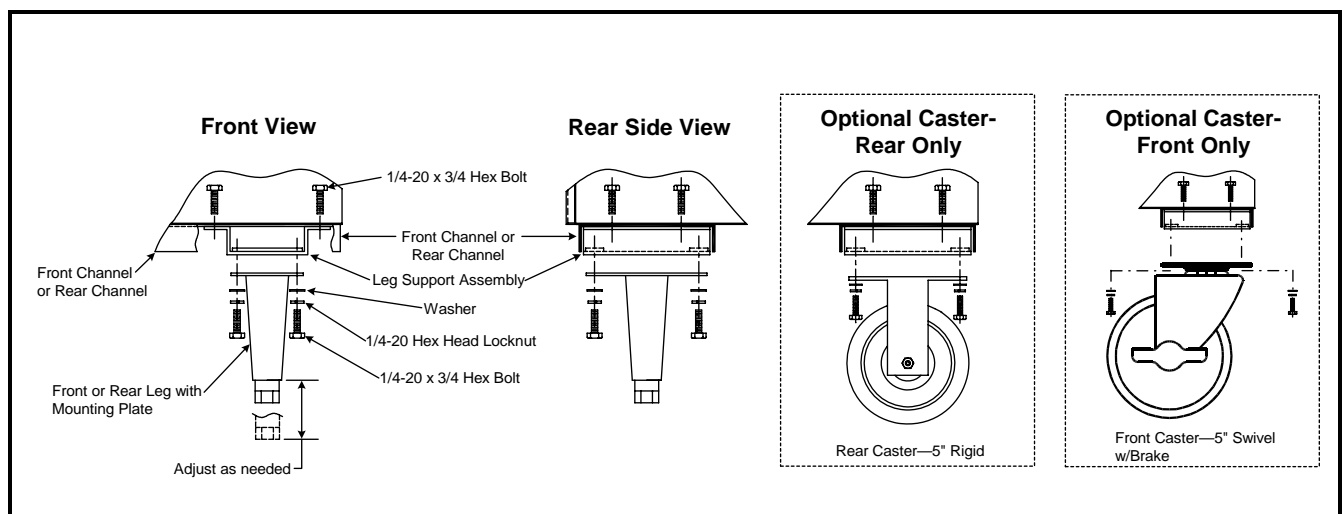

Leg and Caster (Optional) Mounting Installation

**KSCF18G COOL ZONE SERIES GAS FRYERS  
CHAPTER 3: INSTALLATION INSTRUCTIONS**

---

### 3.3 Leveling the Fryer (cont.)

ANSI Z83.11/11a-(Latest Edition) requires a fryer be restrained to prevent tipping when installed in order to avoid the splashing of hot liquid. The means of restraint may be the manner of installation, such as connection to battery of appliances or installing the fryer in an alcove, or by separate means, such as adequate ties (chains, straps, etc.). A bracket has been provided on the fryer back panel for this purpose.

**NOTE:** The installation must be inspected after it is complete to ensure it meets the intent of these instructions. The on-site supervisor and/or operator(s) should be informed that the appliance is installed with restraints. If restraints are removed to move fryer (e.g., to clean beneath and behind, to relocate) ensure that they are re-installed when fryer is returned to its permanently installed position.

For information on fryer restraints, see **Section 2.9**.

### 3.4 Gas Connections

KSCF18G Cool Zone Series gas fryers have obtained CE markings for countries and gas categories shown below:

Countries	Supply Pressures and Gas (mbar)	Appliance Categories	Countries	Supply Pressures and Gas (mbar)	Appliance Categories
BE Belgium	G20 20/25 G31 37	I2E (R) B I3P	GR Greece	G20 20 G31 37 and 50	I12H3P
DE Germany	G20 20 G31 50	I2E I3P	IR Ireland	G20 20 G31 37	I12H3P
DK Denmark	G20 20	I2H	IT Italy	G20 20	I2H
ES Spain	G20 20 G31 37 and 50	I12H3P	LU Luxembourg	G20/G25 20/25 G31 50	I12E3P
FR France	G20/G25 20/25 G31 37 and 50	I12ESI3P	NL The Netherlands	G25 25 G31 50	I12L3P
GB Great Britain	G20 20 G31 37	I12H3P	PT Portugal	G20 20 G31 37	I12H3P

The gas supply (service) line must be the same size or greater than the fryer inlet line. KSCF18G gas fryers are equipped with a ¾-inch (22-mm) male inlet. The gas supply line must be sized to accommodate all gas-fired equipment connected to that gas supply. Consult local gas companies/suppliers or your local contractor for minimum supply line requirements.

**KSCF18G COOL ZONE SERIES GAS FRYERS  
CHAPTER 3: INSTALLATION INSTRUCTIONS**

---

### **3.4 Gas Connections (cont.)**

#### **Supply Line Specifications**

The gas supply lines must be sized as indicated in the chart below, based on the total number of fryers connected to the main gas supply.

<b>Gas Types</b>	<b>Recommended Gas Supply Line Sizes</b>		
	<b>Number of Fryers</b>		
	<b>1</b>	<b>2 to 3</b>	<b>4 or more*</b>
Natural Gas	¾" (22 mm)	1" (28 mm)	1¼" (35 mm)
Propane Gas	½" (15 mm)	¾" (22 mm)	1" (28 mm)

*\* When exceeding 18 feet (6 meters) for a configuration of more than four fryers, it is necessary to provide a 1¼" (35 mm) rigid gas connection.*

 **DANGER**

**All connections must be sealed with a joint compound suitable for the gas being used and all connections must be tested with a solution of soapy water before lighting any pilots.**

**Never use matches, candles, or any other ignition source to check for leaks. If gas odors are detected, shut off the gas supply to the appliance at the main shut-off valve and immediately contact the local gas company or an authorized service agency for service.**

 **DANGER**

**"Dry-firing" your unit will cause damage to the frypot and can cause a fire. Before firing the unit, always ensure that melted shortening, cooking oil, or water is in the frypot.**

 **DANGER**

**Before connecting new pipe to this appliance, the pipe must be blown out thoroughly to remove all foreign material. Foreign material in the burner and gas controls will cause improper and dangerous operation.**

## KSCF18G COOL ZONE SERIES GAS FRYERS CHAPTER 3: INSTALLATION INSTRUCTIONS

---

### 3.4 Gas Connections (cont.)

#### Rigid Connections

Check any installer-supplied intake pipe(s) visually and clean metal particles or other foreign matter from the threads before installing into a service line. If the intake pipes are not clear of all foreign matter, the orifices will clog when gas pressure is applied. When using thread compound on gas piping, use very small amounts and only on male threads. Use a pipe thread compound that is not affected by the chemical action of LP gases. **DO NOT** apply thread compound to the first two pipe threads—doing so will cause clogging of the burner orifices and control valve.

#### Manual Shut-off Valve

This gas service supplier-installed valve must be installed in the gas service line ahead of the fryers in the gas stream and in a position where it can be reached quickly in the event of an emergency.

#### Regulating Gas Pressure

The fryer and its individual shut-off valve must be disconnected from the gas supply piping system during any pressure testing of the gas supply system, especially if the test pressures are in excess of ½ PSI (3,45 kPa/35 mbar).

External gas regulators are not normally required on this fryer. A safety control valve protects the fryer against pressure fluctuations. If the incoming pressure is in excess of ½ PSI (3,45 kPa/35 mbar), **a step-down regulator is required.**

 **DANGER**

**When pressure-testing incoming gas supply lines, disconnect the fryer from the gas line if the test pressure is 3,45 kPa (½ PSI, 14" W.C.) or greater to avoid damage to the fryer's gas piping and gas valve(s).**

- A. **Manifold Pressure:** Your local service technician should check the manifold pressure with a manometer.
  1. Check the rating plate for manifold gas pressures. Natural gas units normally require 4" W.C., and propane units normally require 11" W.C. gas pressure.
  2. Confirm that the arrow forged into the bottom of the regulator body, which indicates gas flow direction, is pointed downstream towards the fryers. The air vent cap is also part of the regulator and should not be removed.
  3. If a vent line from the gas pressure regulator is used, it should be installed in accordance with local codes or in the absence of local codes, with the National Fuel Gas Code, ANSI Z223.1-(Latest Edition).

**KSCF18G COOL ZONE SERIES GAS FRYERS  
CHAPTER 3: INSTALLATION INSTRUCTIONS**

---

### **3.4 Gas Connections (cont.)**

 **WARNING**

**Use a diluted soap solution to find potentially dangerous gas leaks when making new connections.**

- B. **Regulators:** Gas regulators can be adjusted in the field, but no adjustments should be made unless the regulator is out of adjustment or serious pressure fluctuations are observed.
- C. Only qualified service personnel should make adjustments to the regulators.
- D. **Orifices:** The fryer can be ordered to operate on any available gas. The correct combination gas valve, appropriate burner orifices, and pilot burners are installed at the factory. While the valve can be adjusted in the field, only qualified service personnel should make any adjustments with the proper test equipment.

 **DANGER**

**If gas odors are detected, the gas supply must be shut off at the main shut-off valve. The local gas company or FASC should be contacted immediately to fix the problem.**

#### **E. Flexible Couplings, Connectors and Casters:**

1. If the fryer is to be installed with flexible couplings and/or quick-disconnect fittings, the installer must use a heavy-duty AGA design-certified commercial flexible connector of at least ¾" NPT (with suitable strain-relief attachments), in compliance with the Standard for Connectors for Movable Gas Appliances, ANSI Z21.69-(Latest Edition) and Addenda Z21.69a-(Latest Edition). Quick disconnect devices must comply with the Standard for Quick-Disconnect Devices for Use with Gas Fuel, ANSI Z21.41-(Latest Edition).
2. For an appliance equipped with casters, the installation shall be made with a connector that complies with the Standard for Connectors for Movable Gas Appliances, ANSI Z21.69, or Connectors for Moveable Gas Appliances, CAN/CGA-6.16. A quick-disconnect device that complies with the Standard for Quick-Disconnect Devices for Use with Gas Fuel, ANSI Z21.41, or Quick-Disconnect Devices for Use with Gas Fuel, CANI-6.9, must be used. Under no circumstances are the connector and the quick-disconnect device or its associated piping to be used to limit fryer movement.
3. The fryer must be restrained by means independent of the flexible coupling or connector in order to limit the movement of the fryer. Clips are located on the back panel of the fryer for the attachment of restraints.

**KSCF18G COOL ZONE SERIES GAS FRYERS  
CHAPTER 3: INSTALLATION INSTRUCTIONS**

---

### 3.4 Gas Connections (cont.)

4. If it is necessary to disconnect the restraint, it must be reconnected after the fryer has been returned to its originally installed position.

 **WARNING**

**Do not attach accessories to this fryer unless fryer is secured from tipping.  
Personal injury may result.**

- F. After hook-up, bleed the gas line of air to ensure that the pilot light will ignite quickly and evenly.

 **WARNING**

**Qualified personnel MUST perform any adaptation, modification, or gas conversion, if required. Failure to use qualified personnel will void the Frymaster warranty.**

### 3.5 Adjustments/Adaptation To Different Gases

- A. Proper operation of appliances requires the operator to scrupulously inspect the following:
  1. Gas inputs and pressures;
  2. Voltage and polarities of electrical power supplies.
- B. Frymaster gas fryers are manufactured to use the type of gas and pressure specified on the rating plate. When changing gas, **adaptation must be performed by qualified personnel.** Failure to use qualified personnel will void the Frymaster warranty.

### 3.6 Gas Inputs

- A. Nominal "Qn" Heat Input for the KSCF18G Cool Zone Gas fryer is 25 kW.
- B. Inputs for different gases are as follows:

<b>G20</b>	Natural Gas (Type H)	20 mbar/ 8" W.C.
<b>G25</b>	Natural Gas (Type L)	25 mbar/ 10" W.C.
<b>G31</b>	Propane	37 mbar/ 15" W.C.

# KSCF18G COOL ZONE SERIES GAS FRYERS

## CHAPTER 3: INSTALLATION INSTRUCTIONS

### 3.6 Gas Inputs (cont.)

C. Adjustments for different gases are as follows:

ORIFICE SIZE (# / MM)	GAS TYPE	GAS PRESSURE AT REGULATOR		BURNER MARKING	PILOT MARKING
		MBAR	INCH W.C.		
#42 / 2,40	G20	10,0	4,0	Blue	26N
#42 / 2,40	G25	15,0	6,0	Blue	26N
#53 / 1,51	G31	27,0	10,8	Red	16LP

**NOTE:** Outlet gas pressure must be adjusted strictly within the above requirements 5 to 10 minutes after the appliance is operating. For controls and adjustments, please refer to "gas valve" illustrations on Page 3-10. To adjust the pilot flame, turn the pilot adjustment screw clockwise/counter-clockwise until the desired flame-volume is achieved.

### 3.7 Gas Conversion: Procedures

 **DANGER**

**This appliance was configured at the factory for a specific type of gas. Converting from one gas type to another requires the installation of specific gas-conversion components.**

**Switching to a different type of gas without installing the proper conversion components may result in fire or explosion. NEVER ATTACH THIS APPLIANCE TO A GAS SUPPLY FOR WHICH IT IS NOT CONFIGURED!**

**Conversion of this appliance from one type of gas to another should only be performed by qualified, licensed, and authorized installation or service personnel, as defined in Section 1.7 of this manual.**

See Page 3-10 for gas valve illustrations when performing the following conversions.

When converting from G20 to G25 gas, the following procedures apply:

- Equipment replacement is not required.
- Adjust orifice gas pressure by turning the gas valve adjustment screw.
- Seal the screw, after adjustment.

When converting from G20 (or G25) gas to G31 propane (or vice-versa), the following procedures apply:

- Replace gas valve.
- Replace burner orifices.
- Replace pilot(s).

# KSCF18G COOL ZONE SERIES GAS FRYERS

## CHAPTER 3: INSTALLATION INSTRUCTIONS

### 3.7 Gas Conversion: Procedures (cont.)

When converting from G20 (20 mbar) to G25 (25 mbar), or vice-versa, or G31 (37 mbar) to G31 (50 mbar), the following procedures apply:

- Check pilot adjustment and adjust as necessary.
- Other adjustments are not necessary.

Conversion from one gas family to another (e.g. changing from natural gas to propane) requires special components and parts. Contact a Factory Authorized Service Agent for requirements and part numbers.

**Conversions can only be executed by qualified, factory-authorized personnel.**

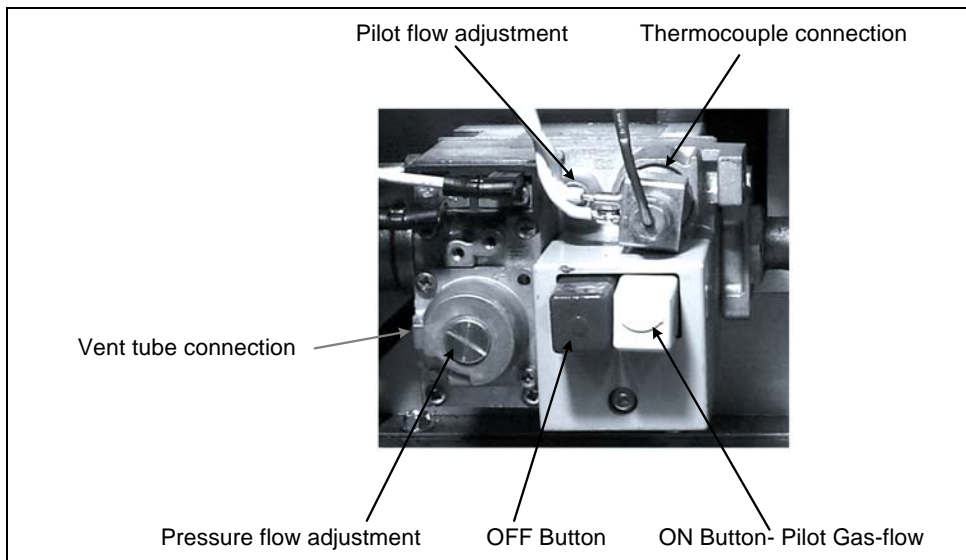

CE Gas Valve

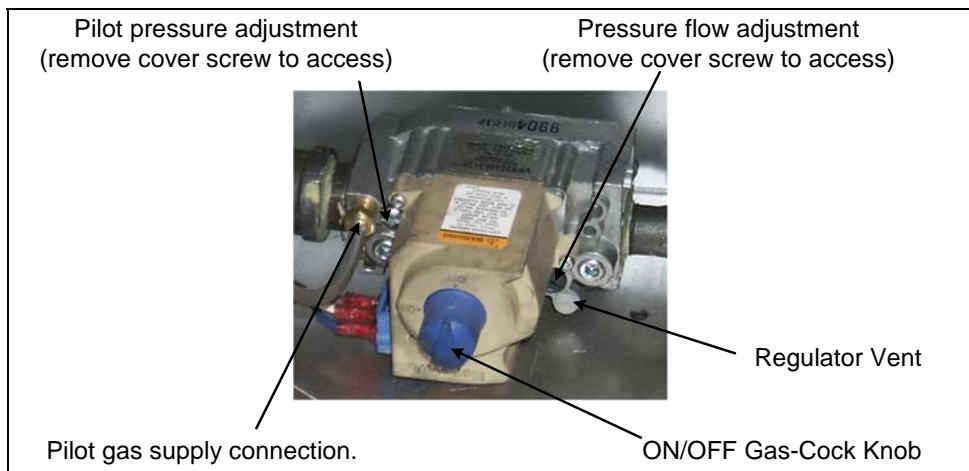

Non-CE Gas Valve

# KSCF18G COOL ZONE SERIES GAS FRYERS

## CHAPTER 3: INSTALLATION INSTRUCTIONS

---

### 3.8 Electrical Connections

 **DANGER**

This fryer is equipped with a three-prong (grounding) plug for protection against electrical shock and must be plugged directly into a properly grounded, three-prong receptacle. **DO NOT CUT, REMOVE, OR OTHERWISE BYPASS THE GROUNDING PRONG ON THIS PLUG!**

 **DANGER**

This appliance requires electrical power for operation. Place the gas valve in the **OFF** position in case of a prolonged power outage. Do not attempt to operate this appliance during a power outage.

Refer to the rating plate and wiring diagram located inside the front door. The diagram can also be found in Section 7.4. The fryer is equipped with a 120VAC/60Hz system for USA/Canada/Mexico operations or a CE-approved 230VAC/50Hz single-phase system for CE/International installations. All electrically operated appliances must be electrically grounded in accordance with local codes or, in the absence of local codes, with the National Electrical Code (ANSI/NFPA 70), the Canadian Electrical Code (CSA C22.2), or the appropriate CE community standards. Do not cut or remove the ground prong from the power cord plug. Do not attempt to use this appliance in a power outage.

### 3.9 Safety Switches

#### A. Fryer with KFC-1 Computer

This fryer/filter system is equipped with a drain valve safety switch and a frypot float-switch on each of the two-battered fryers. Drain-valve safety switches de-energize the control circuit during the filter process, thus providing an additional safety feature. Always leave the computer ON when filtering.

The KFC-1 computer monitors cooking operations. The computer logs the number of cook sequences and locks out the cook cycle after a preset number is reached. The drain-valve must be opened, the oil must be filtered, and the drain-valve closed before the KFC-1 computer will allow a cook cycle. After filtering, always allow the frypot to refill with oil and heat to setpoint before engaging a cook cycle.

**See the accompanying *KFC-1 SMS Cooking Computer User Manual* for more detailed information.**

# KSCF18G COOL ZONE SERIES GAS FRYERS

## CHAPTER 3: INSTALLATION INSTRUCTIONS

### 3.9 Safety Switches (cont.)

#### B. Other Fryer/Filter Switches

1. **Drain Valve Microswitch:** The computer will display DRAIN OPEN when the drain valve is opened. The computer will lockout, preventing any cooking operation until EXIT/COOL FILTER is pressed.

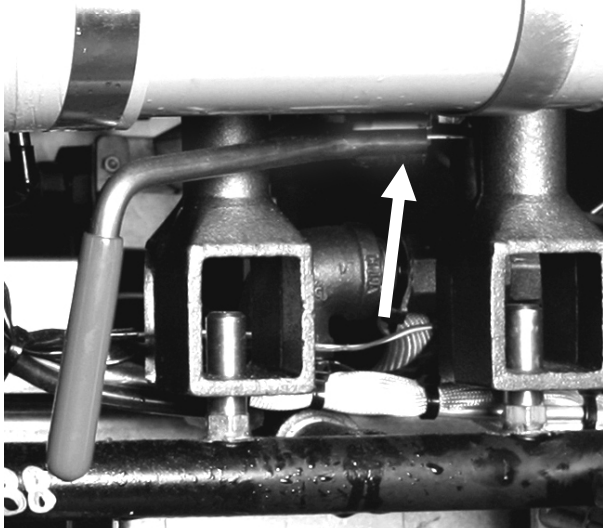

A microswitch is located on the red handle at the drain valve.

2. **Float-Switch:** Located in the frypot. Designed as a safety switch, it deactivates the gas valve, preventing burner ignition until the oil level extends above the heating tubes.

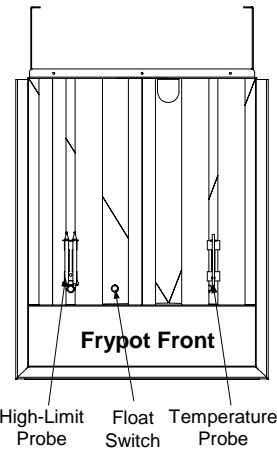

3. **High-limit Reset:** Located in the right fryer cabinet under the control panel. This switch is used to reset the high-limit if the cooking medium has reached high temperature safety limits. The high-limit sensor bulb is mounted inside the frypot between the two left-most burner tubes.

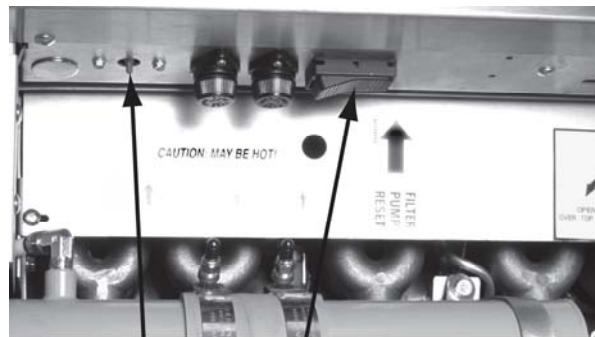

High-limit Reset Switch Manual Filter Override Switch

4. **Manual Filter Override Switch:** Also located in the right fryer control panel of the fryer battery. This rocker switch (older units have toggle switches) allows the operator to manually operate the filtration system if a problem develops with the auto filtration functions.

# KSCF18G COOL ZONE SERIES GAS FRYERS

## CHAPTER 3: INSTALLATION INSTRUCTIONS

### 3.9 Safety Switches (cont.)

#### C. Filtering: Drain Valve and Oil Return Handles

1. **Drain Valve Handle: RED HANDLE.**  
Push the red handle (located in the fryer cabinet) to the right to open the drain valve when filtering. After all oil has drained from the frypot and/or polishing is complete, push the red handle left to close the drain valve.
2. **Oil Return Handle: YELLOW LABEL.**  
The handle beneath the yellow *oil return* label allows you to choose over-the-top or rear flush oil return. Pull and turn the handle to the desired oil return method to open the oil return valve and activate the pump motor. After the frypot is refilled and filtering is complete, turn and push the oil return handle to close the oil return valve and deactivate the pump motor. Activate this handle only when filtering.

See Chapter 5 for more information on filtering.  
See Chapter 7 for troubleshooting information.



Drain valve handle (red).

Oil return handle (yellow label).

#### **⚠ DANGER**

Always ensure that the over-the-top oil return faucet is located over the frypot or an appropriate container before activating the over-the-top oil return system. If not, the hot oil will spill and may cause burns.

#### **⚠ DANGER**

Allow oil to cool to 100°F (38°C) before draining into a metal container, stockpot, or disposal unit.

#### **⚠ DANGER**

When draining oil into a disposal unit or portable filter unit, do not fill above the maximum fill line located on the container.

**KSCF18G COOL ZONE SERIES GAS FRYERS  
CHAPTER 3: INSTALLATION INSTRUCTIONS**

---

### **3.10 Initial Cleaning Before Startup**

New units are wiped clean with solvents at the factory to remove any visible signs of dirt, oil, and grease remaining from the manufacturing process. Then, they are coated lightly with oil. Wash thoroughly with hot, soapy water to remove any film residue and dust or debris before food preparation. Then, rinse and wipe dry. In addition, wash any accessories shipped with the unit. Close the drain valve completely and remove the crumb screen. Ensure the screws securing the temperature probe to the bracket between heating tubes are tight.

 **WARNING**

**All droplets of water must be removed from the frypot before filling with shortening. Failure to do so will cause hot oil to splatter and injure the operator.**

### **3.12 Final Preparation**

1. The KSCF18G frypot shortening capacity is approximately 40.5 kg (90 lb).
2. Ensure fryer power switches are OFF.
3. **Cooking Oil:** Fill the fryer to the bottom OIL LEVEL line scribed into the back of the frypot. Replace the basket support screen.

 **WARNING**

**Never operate fryer without enough oil, shortening, or water in the frypot to cover the heating tubes.**

 **WARNING**

**NEVER set a complete block of solid shortening on top of heating tubes. To do so will damage the frypot and increase the potential for flash-point shortening temperatures and subsequent fire.**

4. **Solid Shortening:** Either pre-melt solid shortening on another appliance first or cut it into small pieces and pack it tightly into the cool zone at the bottom of the frypot. Take care not to disturb the temperature probe or high-limit thermostat. If solid shortening is packed into the frypot, ensure the float switch is in the "up" position.

# KSCF18G COOL ZONE SERIES GAS FRYERS

## CHAPTER 3: INSTALLATION INSTRUCTIONS

### 3.11 Final Preparation (cont.)

**NOTE: If the float switch is blocked in "down position" with solid shortening, the fryer will not heat. Always ensure that the float switch is in the "up" position when packing solid shortening into frypot.**

- KFC-1 Cooking Computer:**  
Turn computer ON (this also turns the *fryer* ON if equipped with electronic ignition). The computer will cycle the burners ON and OFF (melt cycle). This is indicated by heat icons located on either side of the KFC-1 product buttons, which will cycle ON and OFF with the fryer. The computer will display LOW until the shortening reaches 180°F (82°C).

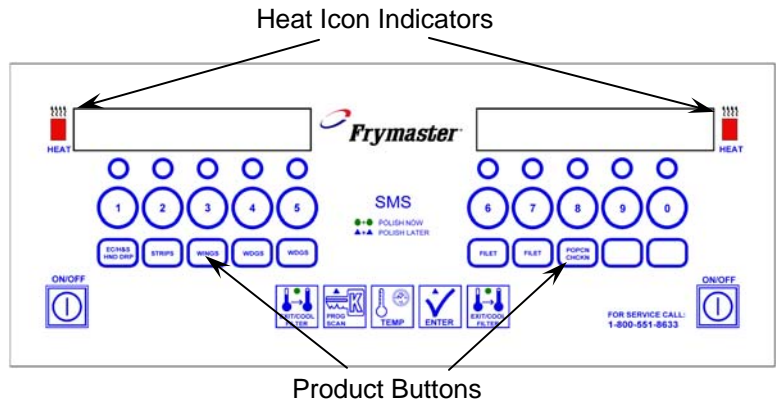

At 180° F (82°C), the fryer goes into continuous heat mode. The computer will display actual oil temperature until setpoint is reached. At setpoint temperature, the computer will display **DROP**.

- After shortening reaches the setpoint temperature, let the burners cycle at least four times, then insert a thermometer or pyrometer near the temperature sensing probe approximately 3-in. (7.5-mm) deep into the shortening. When the burners cycle on after the fourth time, the thermometer should read within  $\pm 5^\circ\text{F}$  ( $\pm 2^\circ\text{C}$ ) of the computer temperature setting.
- When the frypot is filled and the shortening melted, replace the basket-support screen over the heating tubes.

#### **! WARNING**

**Do not bang fry baskets or other utensils on the fryer's joiner strip. The strip is present to seal the joint between the frypots. Banging fry baskets on the strip to dislodge shortening will distort the strip, adversely affecting its fit. It is designed for a tight fit and should only be removed for cleaning.**

**For pilot lighting instructions, see Chapter 4.  
For filtration instructions, see Chapter 5.**

# KSCF18G COOL ZONE SERIES GAS FRYERS

## CHAPTER 4: DAILY OPERATION

### 4.1 General Use

1. At opening, always check that the power switch and the computer are OFF.
2. For consistent quality product, convenience, and long-term savings, use a high-quality liquid shortening.
3. If using solid shortening, never melt a block of shortening by placing an entire block in the fryer vessel. Cut it into small pieces and pack it around fryer components.
4. Although 350°F (177°C) is the recommended temperature for most cooking operations, set the fryer at the lowest possible temperature which produces a high quality end product while ensuring maximum life for your oil.

### 4.2 Start-Up Procedures

1. If the fryer is empty, pour enough oil into the frypot to fill it to the bottom OIL LEVEL line scribed on the rear wall. If solid shortening is used, melt the shortening following procedures in Section 3.11, *Final Preparation*.
2. A. **Pilot lighting procedures – Standing Pilot:**
  - a. Turn off the manual shut-off valve on the incoming service line.
  - b. Turn the operating thermostat to OFF.
  - c. Depress the Pilot Off button (red) on the combination safety gas valve to turn it off.
  - d. Wait at least five minutes for any accumulated gas to disperse.
  - e. Open the manual shut-off valve on the incoming service line.
  - f. Press and hold the white pilot light button and repeatedly press the piezo ignitor button until the pilot lights. Release the white button after approximately 45-60 seconds.

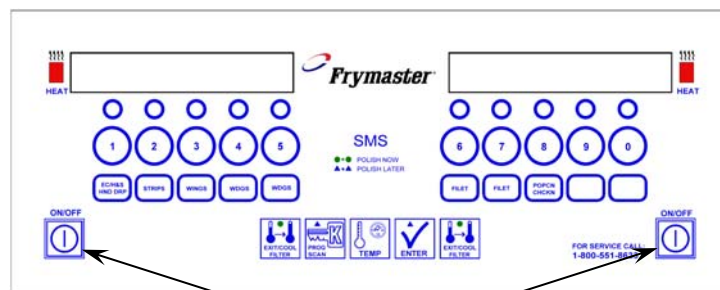

ON/OFF Buttons

**KSCF18G COOL ZONE SERIES GAS FRYERS**  
**CHAPTER 4: DAILY OPERATION**

---

## 4.2 Start-Up Procedures (cont.)

- g. If the pilot does not stay lit, depress the white pilot light button and re-light the pilot (repeat Step f above). Hold the button in longer before releasing. Trapped air may necessitate re-lighting the pilot several times until gas flow is constant.
- h. When the pilot stays lit, release the white pilot light button.
- i. Turn the thermostat to any ON setting and ensure the main burner ignites from the pilot.

### B. Pilot lighting procedure – Electronic Ignition

- a. Turn gas "ON."
- b. Turn electric power "ON" with the appropriate rocker switch or controller/computer.
- c. The ignition module will energize the pilot gas supply and the ignitor. The ignitor spark will ignite the pilot gas. The presence of the pilot flame is then proven by a flame sensor, which sends a signal to the main gas supply, opening the valve. The operating thermostat or computer/controller controls the fryer after ignition.

 **WARNING**

**In the event of prolonged power failure, the ignition module will shut down and lock out the system. Turn the unit power "OFF" and then back "ON" after power has been re-established.**

- d. If the pilot flame fails, the ignition module will shut down and lock out the system. To restart, turn the electric power "OFF," wait approximately 5 minutes for the system to recycle itself, and then turn the power "ON" again. Repeat Steps a-c.
3. KFC-1 Cooking Computer: Turn the computer ON and select cooking program as described in the KFC-1 SMS Cooking Computer User Guide.

## 4.3 Filtering

 **DANGER**

**When filtering, never leave the filter unattended. The filtered oil is at or near 350°F (177°C). Ensure all hoses are connected properly and drain handles are in their proper position prior to operating any switches or valves.**

**KSCF18G COOL ZONE SERIES GAS FRYERS  
CHAPTER 4: DAILY OPERATION**

---

 **DANGER**

**The crumb tray in fryers equipped with a filter system must be emptied into a fireproof container at the end of frying operations each day. Some food particles can spontaneously combust if left soaking in certain shortening material.**

 **WARNING**

**Filter one frypot at a time. The filter pan is designed to safely hold the oil from one fryer only.**

1. The KFC-1 Computer must remain ON during filter operations for proper filter function.
2. Filter the shortening **at least once daily** or more frequently if cooking is heavy. This assures the longest life possible for the shortening, a better taste to the food being prepared, and minimizes flavors being transferred from batch to batch.
3. If using solid shortening, clear return lines before turning off the filter motor by allowing the pump to run for approximately 15-30 seconds once air bubbles appear in the frypot from the oil return line. Failure to do so increases the likelihood that solid shortening will solidify and clog the lines.

**NOTE:** If using over-the-top oil return, allow the faucet to sputter for 15-30 seconds.

**See Chapter 5 for detailed filtration procedures.**

## **4.4 Closing**

1. When closing at night, filter shortening in all fryers and drain the filter lines. Cover the open tanks of oil. Turn the computer OFF. **On CE units with standing pilots, press the red button on the combination safety gas valve to turn off.**
2. When shutting down for periods longer than overnight, drain shortening and clean the frypot thoroughly. After cleaning, discard the shortening or filter it and return it to the frypot. Cover the frypot with the appropriate frypot cover. Turn both the power switch and computer OFF. **On CE units with standing pilots, press the red button on the gas valve to turn off.**

# KSCF18G COOL ZONE SERIES GAS FRYERS

## CHAPTER 5: FILTRATION

### 5.1 General

#### WARNING

The on-site supervisor is responsible for ensuring that operators are made aware of the inherent hazards of operating a hot oil filtering system, particularly the aspects of oil filtration, draining, and cleaning procedures.

To conduct filter operations with the KFC-1 Cooking Computer installed on the fryer, **ALWAYS** leave the computer **ON** when filtering. The computer must sense the drain valves opening and closing in order to allow fryer operation.

For consistent product quality, convenience, and long-term savings use a high-quality liquid shortening or vegetable oil.

If using solid shortening, always ensure the return lines are clear before turning off the filter pump. Hang any flexible lines up to drain. Solid shortening will solidify as it cools and clog the lines.

### 5.2 Filter Preparation

Assemble filtering tools. These are supplied with the filter starter kit (at right):

- **L-shaped Teflon Brush:** Used to clean frypot sides, heating tubes, and to dislodge sediment during filtration or oil change.
- **Clean-out Rod:** Used to dislodge heavy debris in the drain tube (when needed).
- **Filter Powder.**
- **Filter Paper.**

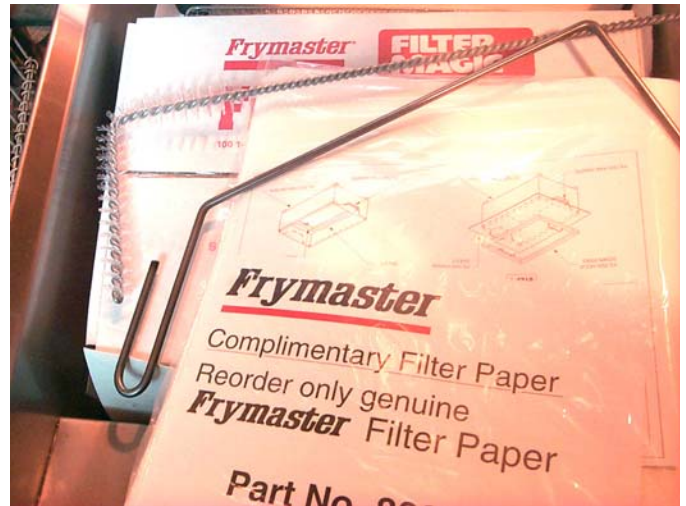

The following tools are not required, but are recommended to make the filtering task easier.

- **Measuring Cup:** Used to measure filter powder.
- **Stainless Steel Crumb Scoop:** Used to remove large debris from oil prior to filtering.

**NOTE:** Always wear oil-resistant, insulated gloves and/or protective gear when working with hot oil.

# KSCF18G COOL ZONE SERIES GAS FRYERS

## CHAPTER 5: FILTRATION

---

### 5.2 Filter Preparation (cont.)

1. Put on protective gear/gloves. Pull the filter pan out of the filter cabinet. Remove cover.

2. Remove crumb screen. If crumbs are present in the crumb screen, empty the screen into a fireproof container. Thoroughly wash the screen in hot, soapy water, rinse, then dry.

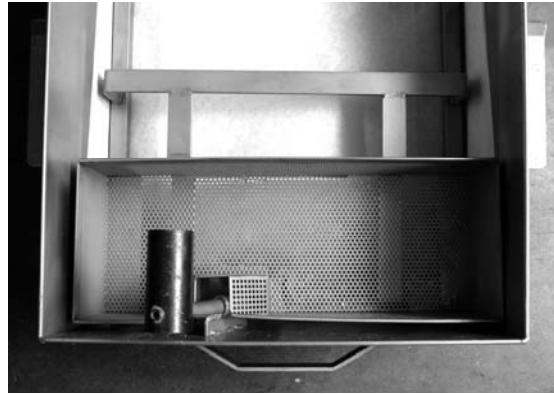

3. Remove the hold-down ring.



4. Remove and discard old filter paper sheet from the filter pan.



**KSCF18G COOL ZONE SERIES GAS FRYERS  
CHAPTER 5: FILTRATION**

---

**5.2 Filter Preparation (cont.)**

5. Remove the filter screen from the bottom of the pan.



6. Thoroughly clean the pan and all pan components as described for the crumb screen (Step 2).

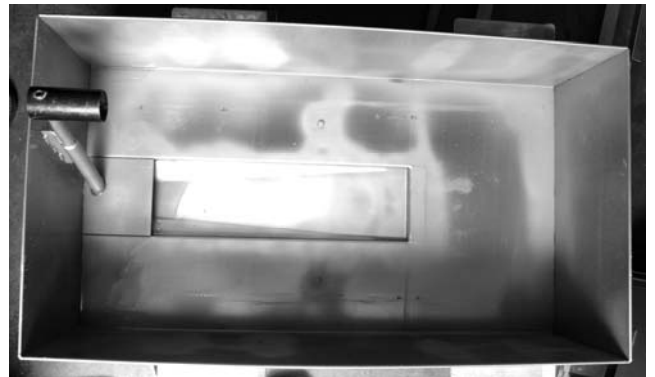

7. Inspect the pickup tube and ensure vent hole is open and free of shortening/debris.



**KSCF18G COOL ZONE SERIES GAS FRYERS**  
**CHAPTER 5: FILTRATION**

---

## 5.2 Filter Preparation (cont.)

8. Replace filter screen and drape one sheet of filter paper across the filter pan. **The filter screen must be installed prior to filter paper placement or the filter won't operate correctly.**

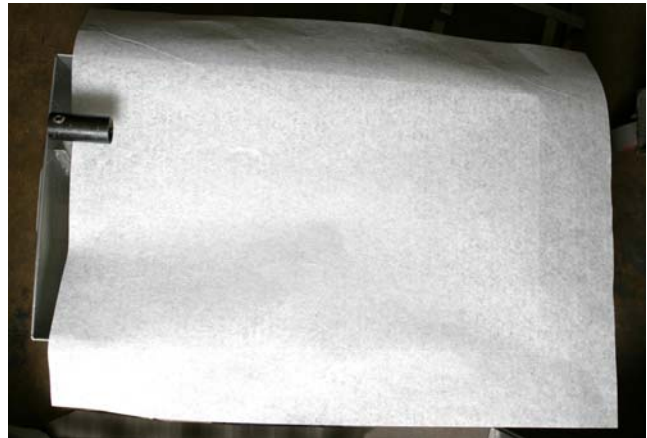

9. Reinstall the hold-down ring. Ensure filter paper is properly aligned under the hold-down ring. Press the filter paper into place with the hold-down ring, ensuring the paper laps against the walls of the filter pan.



10. Sprinkle 1 cup (8 ounces/227 grams) of filter powder evenly over the paper. Use a measuring cup or scoop to evenly distribute filter powder over the filter sheet.

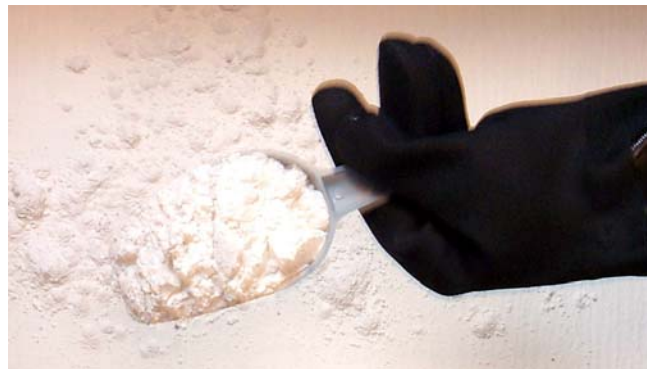

11. Replace the crumb screen. Ensure crumb screen is cleaned throughout the workday.

12. Return pan cover to the filter pan.

13. Return filter pan to fryer cabinet, ensuring that the two drainpipe extensions are directly over the opening in the filter pan cover.

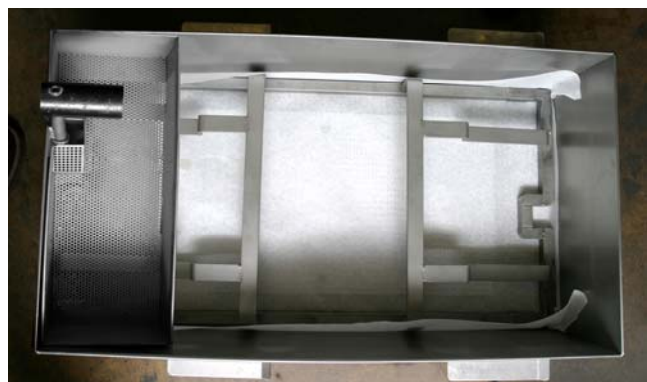

**KSCF18G COOL ZONE SERIES GAS FRYERS  
CHAPTER 5: FILTRATION**

---

### 5.3 Filter Operations

**NOTE:** When *left* and *right* are indicated, refer to the *operator's* left and right.

**⚠ DANGER**

Draining and filtering of cooking oil or shortening must be accomplished with care to avoid a serious burn caused by careless handling. The oil to be filtered is at or near 350°F (177°C). Ensure all hoses are connected properly and drain handles are in their proper position before operating any switches or valves. Wear all appropriate safety equipment when draining and filtering oil.

**⚠ DANGER**

Always ensure that the over-the-top oil return faucet is located over the frypot or an appropriate container before activating the over-the-top oil return system. If not, the hot oil will spill and may cause burns.

**⚠ DANGER**

Allow oil to cool to 100°F (38°C) before draining into a metal container, stockpot, or disposal unit.

**⚠ DANGER**

Do not drain more than one frypot at a time into the built-in filtration unit to avoid overflow and spillage of hot oil.

**⚠ DANGER**

When draining oil into a disposal unit or portable filter unit, do not fill above the maximum fill line located on the container.

1. Remove large debris floating in the oil.

**NOTE:** Always heat oil to operating temperature before filtering.



Remove large debris from frypot prior to filtering.

**KSCF18G COOL ZONE SERIES GAS FRYERS**  
**CHAPTER 5: FILTRATION**

---

### 5.3 Filter Operations (cont.)

2. Remove the support grid from the frypot using the clean-out rod. Stir the oil with the L-shaped Teflon brush to suspend debris prior to draining.



Removing support grid from frypot prior to draining.

3. Open the fryer drain valve by pushing the red handle (under the frypot to be filtered) to the right until it is completely open. Continue stirring the oil.



Push the red handle right to open drain valve. Oil will start to drain into filter pan.

### 5.3 Filter Operations (cont.)

4. Use the L-shaped brush to scrub the frypot, and to assist in sediment removal. Brush the frypot sides and between the tubes to remove debris. Use the clean-out rod to clear the drain if necessary.
5. Open the oil return valve by pulling and turning the handle under the yellow label.



Use the L-shaped brush to loosen debris as oil drains from the frypot.

**⚠ DANGER**  
Always ensure that the over-the-top oil return faucet is located over the frypot or an appropriate container before activating the over-the-top oil return system. If not, the hot oil will spill and may cause burns.

- Turn the handle to the left to use over-the-top oil return. This will return the oil to the frypot through the oil return faucet.
- Turn the handle to the right to use rear flush oil return. This will return the oil to the frypot through the spout inside the bottom of the frypot.

The oil will drain into the filterpan and return to the pot by the chosen method.

6. Close the red drain valve by pushing the handle inward until it stops. The fryer will not operate unless the computer senses a closed microswitch circuit. Leave the oil return handle (yellow label) open to allow pump to run and frypot to fill with filtered oil.
7. When filtering is complete:
  - **Rear Flush Oil Return:** Allow the filter to pump bubbles into the fryer for 15-30 seconds to ensure the oil return lines are clear of oil.
  - **Over-the-top Oil Return:** Allow the faucet to sputter for 15-30 seconds to ensure the oil return lines are clear of oil.



Pull and turn the oil return handle to open the oil return valve and activate the filter pump.



Bubbling oil indicates that air is flowing through the return lines and all oil/shortening has been evacuated from the lines.

**KSCF18G COOL ZONE SERIES GAS FRYERS**  
**CHAPTER 5: FILTRATION**

---

### 5.3 Filter Operations (cont.)

8. Turn off the filter by turning the oil return handle to the CLOSED position and pushing the oil return handle in until it stops. This closes the oil return valve under the filtered frypot and stops the filter pump motor.

**⚠ DANGER**

**The crumb tray in fryers equipped with a filter system MUST be emptied into a fireproof container at the end of frying operations each day. Some food particles can spontaneously combust if left soaking in oil.**



Empty contents of the crumb screen into a fireproof container immediately after filtering is complete.

9. Repeat Steps 1 and 2 in Section 5.2. Remove crumb screen and empty debris into a fireproof container. If possible, wash all filter pan components in hot, soapy water. Rinse and dry thoroughly (Section 5.2, Step 7). If not, the filter pan should be thoroughly cleaned at the close of each day, as previously described.

**Filtration system troubleshooting information can be found in Chapter 7.**

# KSCF18G COOL ZONE SERIES GAS FRYERS

## CHAPTER 6: PREVENTATIVE MAINTENANCE

---

Well-maintained equipment operates more efficiently and lasts longer. Keep the fryer clean during the day and thoroughly clean it at the end of each day.

 **DANGER**

**Never attempt to clean the fryer during the cooking process or when the frypot is filled with hot oil. If water comes in contact with oil heated to cooking temperature, it will cause spattering of the oil, which can result in severe burns to nearby personnel.**

### 6.1 Daily

Wash all removable parts. Clean all exterior surfaces. Do not use cleansers, steel wool, or any other abrasive material on stainless steel. Filter the oil and replace it if necessary. Filter oil more often under heavy use conditions (e.g., frying heavily breaded products).

 **WARNING**

**Use a commercial-grade cleaner formulated to effectively clean and sanitize food-contact surfaces. Read the directions for use and precautionary statements before use. Particular attention must be paid to the concentration of cleaner and the length of time the cleaner remains on the food-contact surfaces.**

 **WARNING**

**Water MUST NOT be allowed to drain into the filter pan or filter system. Irreversible damage will result if water is allowed into the system, and all applicable warranties will be voided.**

### 6.2 Weekly

Completely drain the frypot into either the filter or a steel container. Do not use a plastic bucket or glass container.

- Clean the frypot with a high grade cleaner or hot water and a strong detergent.
- Close the drain valve and refill with either the cleaning solution or water and detergent.
- Scrub frypot walls and heating tubes. Then drain frypot and rinse in clear water.
- Once cleaning is completed, drain, rinse, and dry thoroughly.
- Refill with shortening as directed in Section 3.11 of this manual.

## KSCF18G COOL ZONE SERIES GAS FRYERS CHAPTER 6: PREVENTATIVE MAINTENANCE

---

### 6.3 Periodic/Annual

This appliance should be inspected and adjusted periodically by qualified service personnel as part of a regular kitchen maintenance program.

**Frymaster and Dean recommend that a Factory Authorized Servicer should inspect this appliance at least annually, as follows:**

- Inspect the cabinet **inside-and-out, front-and-rear** for excessive oil build-up.
- Verify that debris or accumulations of solidified oil or shortening do not obstruct the flue opening.
- Verify that burners and associated components (e.g., gas valves, pilot assemblies, ignitors) are in good condition and functioning properly. Inspect all gas connections for leaks and verify that all connections are properly tightened.
- Verify that the burner manifold pressure matches the pressure specified on the fryer's rating plate.
- Verify that the temperature and high-limit probes are connected, tightened, and functioning properly, and that mounting hardware and probe guard are present and properly installed.
- Verify that component box components (e.g., computer/controller, transformers, relays, interface boards) are in good condition and free of oil build-up and other debris. Inspect the component box wiring and verify that connections are tight and that wiring is in good condition.
- Verify that all safety features (e.g., drain safety switches, reset switches) are present and functioning properly.
- Verify that the frypot/cookpot is in good condition and free of leaks and that the frypot/cookpot insulation is in serviceable condition. Verify that the frypot tube diffusers are present and in good condition (i.e. no visible deterioration or damage).
- Verify that wiring harnesses and connections are tight and in good condition.

#### **Built-in Filtration:**

- Inspect all oil-return and drain lines for leaks and verify that all connections are tight.
- Inspect the filter pan for leaks and cleanliness. If there is a large accumulation of crumbs in the crumb basket, advise the owner/operator that the crumb basket should be emptied into a fireproof container and cleaned daily.
- Verify that all O-rings and seals, including those on quick-disconnect fittings, are present and in good condition. Replace O-rings and seals if worn or damaged.

**KSCF18G COOL ZONE SERIES GAS FRYERS**  
**CHAPTER 6: PREVENTATIVE MAINTENANCE**

---

### **6.3 Periodic/ Annual (cont.)**

Check filtration system integrity as follows:

- With the filter pan empty, place each oil return handle in the OPEN position, one at a time. Using rear flush oil return, verify that the pump activates and that bubbles appear in the oil of the associated frypot. Using over-the-top oil return, verify that the pump activates and that the faucet sputters.
- Close all oil return valves (i.e., place all oil return handles in the CLOSED position). Verify proper functioning of each oil return valve by activating the filter pump using the lever on one of the oil return handle microswitches. No air bubbles should be visible in any frypot and the over-the-top faucet should not sputter.
- Verify that the filter pan is properly prepared for filtering, then drain a frypot of oil heated to 350°F (177°C) into the filter pan and close the frypot drain valve. Place the oil return handle in the OPEN position. Allow all oil to return to the frypot. The frypot should refill in no more than 2 minutes and 30 seconds. Move the oil return handle to the CLOSED position when the oil return lines are clear of oil (indicated by bubbles in the oil in the frypot or sputtering in the over-the-top faucet).

**To ensure good fryer health and a safe environment, the fryer should be checked and adjusted periodically by qualified service personnel as part of a regular kitchen maintenance program.**

### **6.4 Stainless Steel**

All stainless steel fryer outer parts should be wiped regularly with hot, soapy water during the day and with a liquid cleaner designed for this material at the end of each day.

- Do not use steel wool, abrasive cloths, cleansers, or powders!
- Do not use a metal knife, spatula, or any other metal tool to scrape stainless steel! Scratches are almost impossible to remove.
- If it is necessary to scrape the stainless steel to remove any encrusted materials, soak the area to loosen the material and use a wood or nylon scraper only.

# KSCF18G COOL ZONE SERIES GAS FRYERS

## CHAPTER 7: TROUBLESHOOTING

---

### 7.1 Introduction

This section provides an easy reference guide to some of the common problems that may occur during the operation of this equipment. The troubleshooting guides that follow are intended to help correct, or at least accurately diagnose, problems with this equipment. Although this chapter covers the most common problems reported, you may encounter problems, which are not addressed. In such instances, the Frymaster/Dean Technical Service staff will make every effort to help you identify and resolve the problem.

When troubleshooting a problem, always use a process of elimination starting with the simplest solution and working through to the most complex. Never overlook the obvious – anyone can forget to plug in a cord or fail to close a valve completely. Most importantly, always try to establish a clear idea of why a problem has occurred. Part of any corrective action involves taking steps to ensure that it doesn't happen again. If a controller malfunctions because of a poor connection, check all other connections, too. If a fuse continues to blow, find out why. Always keep in mind that the failure of a small component may often be indicative of potential failure or incorrect functioning of a more important component or system.

**Before calling a service agent or the Frymaster/Dean HOTLINE (1-800-551-8633):**

- **Verify that electrical cords are plugged in and that circuit breakers are on;**
- **Verify that frypot drain valves are fully closed;**
- **Verify that gas line is properly connected.**

 **DANGER**

**Never attempt to move a fryer containing hot cooking oil or to transfer hot cooking oil from one container to another.**

 **DANGER**

**Use extreme care when testing electrical circuits. Live circuits will be exposed.**

 **WARNING**

**Inspection, testing, and repair of electrical components should be performed only by qualified service personnel. The equipment should be unplugged when servicing, except when electrical tests are required.**

 **DANGER**

**NEVER use open flame to melt solidified shortening-blockage in the filtration system. Open flame increases the chance of fire and operator injury.**

**KSCF18G COOL ZONE SERIES GAS FRYERS  
CHAPTER 7: TROUBLESHOOTING**

**7.2 Fryer Troubleshooting**

<p><b>7.2.1</b></p>	<p><b>Computer fails to turn ON when ON/OFF button is pressed.</b></p>	<ol style="list-style-type: none"> <li>1. Check wall circuit breakers. Reset, if necessary.</li> <li>2. Check fryer connection to external power source.</li> <li>3. Disconnect fryer from power supply.</li> <li>4. Check fuses and replace, if necessary (see photo at left).</li> <li>5. Power surge/outage may have temporarily locked out computer.</li> </ol> <p>If the fryer still fails to turn ON when the ON/OFF button is pressed, contact an authorized servicer.</p>
<div data-bbox="155 480 724 804" data-label="Image"> </div> <p data-bbox="185 808 685 867">Fuses are located inside the cabinet, under the component box.</p>		
<p><b>7.2.2</b></p>	<p><b>Computer is ON, but the gas valves fail to energize.</b></p>	<ol style="list-style-type: none"> <li>1. Ensure float-switch is not stuck in "down" position. Contact an authorized servicer for service if float-switch is defective.</li> <li>2. If computer displays KHOS 0% reset high-limit thermostat (located in the fryer cabinet under the control panel). Contact an authorized servicer for service if high-limit will not reset.</li> </ol>
<p><b>7.2.3</b></p>	<p><b>Actual frypot temperature differs from the computer setpoint temperature.</b></p>	<ol style="list-style-type: none"> <li>1. Turn fryer ON.</li> <li>2. Select a product number and allow the fryer to heat for approximately 30 minutes to stabilize shortening temperature at desired setpoint.</li> <li>3. Place a thermometer within 1 inch (25 mm) of the temperature probe (see illustration, Page 7-3).</li> <li>4. Press the computer temperature button to check frypot temperature. Press the computer temperature button twice to view setpoint temperature for the product number chosen.</li> </ol>

**KSCF18G COOL ZONE SERIES GAS FRYERS**  
**CHAPTER 7: TROUBLESHOOTING**

**7.2 Fryer Troubleshooting (cont.)**

<p><b>7.2.3 (cont.)</b></p>	<p><b>Actual frypot temperature differs from computer setpoint temperature.</b></p>	<p>5. The thermometer temperature should be within 5 10°F (5 5°C) of the computer display temperature.</p> <p><b>Yes:</b> System is maintaining temperature properly.</p> <p><b>No:</b> Ensure the probe tip is 1/8" from the top of the burner tubes (see illustration). If the probe adjustment is correct, the computer probe circuit may be faulty. If probe adjustment is incorrect, it will require adjustment.</p>
		<p>6. Contact your authorized servicer if any of the following occurs during this test:</p> <ol style="list-style-type: none"> <li>a. Computer probe circuit is suspected as faulty.</li> <li>b. Temperature probe requires adjustment.</li> <li>c. Computer fails to call for heat during the calibration test.</li> </ol>

**KSCF18G COOL ZONE SERIES GAS FRYERS  
CHAPTER 7: TROUBLESHOOTING**

**7.2 Fryer Troubleshooting (cont.)**

<b>7.2.4</b>	<b>G U D I Q % R S H Q message remains after closing drain valve.</b>	<ol style="list-style-type: none"> <li>1. Computer was turned OFF while draining frypot.</li> <li>2. Close drain valve. Turn computer OFF and ON again. Computer display will read ON.</li> <li>3. Open drain valve. Computer display will read G U D I Q % R S H Q . After 30 seconds the computer display will read I I O O .</li> <li>4. Close drain valve.</li> <li>5. Fill frypot with shortening. Press EXIT/COOL FILTER when ready to cook.</li> <li>6. If the computer message G U D I Q % R S H Q remains after Steps 1-4, contact an authorized servicer. Possible malfunctions are:             <ol style="list-style-type: none"> <li>a. Drain microswitch may be faulty.</li> <li>b. Drain circuit is suspect.</li> <li>c. Computer is suspect.</li> </ol> </li> </ol>
<b>7.2.5</b>	<b>Pump motor won't start or stops during filtering.</b>	<ol style="list-style-type: none"> <li>1. The motor thermal overload or the 10 amp circuit breaker has tripped. If the thermal overload trips, wait approximately 45 minutes. Press the button on the end of the filter motor. If the 10 amp circuit breaker trips, reset it (located under the control panel of the right-hand fryer).</li> <li>2. If you have to do this repeatedly, stop resetting the overload or circuit breaker and contact an authorized servicer.</li> </ol> <p><b>NOTE:</b> This is usually caused by allowing large particles of food to enter the pump during filtering. Ensure that the filter paper and crumb screen are properly in place.</p>

**KSCF18G COOL ZONE SERIES GAS FRYERS  
CHAPTER 7: TROUBLESHOOTING**

---

**7.2 Fryer Troubleshooting (cont.)**

<b>7.2.6</b>	<b>Main burner malfunctions.</b>	<p>A. Main burner will not ignite; no gas is present at main burner.</p> <ol style="list-style-type: none"> <li>1. Check that float switch is not stuck in the "down" position.</li> <li>2. Check and reset the high-limit switch.</li> <li>3. The combination gas valve and/or electronic ignition system may be defective; contact an authorized servicer for service.</li> </ol> <p>B. Main burner flames are small and appear lazy; shortening does not come up to temperature quickly. Contact an authorized servicer for service.</p> <p>C. Fryer will not reach setpoint temperature and/or runs erratically.</p> <ol style="list-style-type: none"> <li>1. Incorrect location or adjustment of sensor probe. Contact an authorized servicer for service.</li> <li>2. Defective temperature sensor. Contact an authorized servicer for service.</li> </ol> <p>D. Fryer shortening temperature cannot be controlled; fryer runs at high-limit temperature. Possible causes are:</p> <ol style="list-style-type: none"> <li>1. Defective operating thermostat. Contact an authorized servicer for service.</li> <li>2. Defective temperature probe. Contact an authorized servicer for service.</li> </ol>
--------------	----------------------------------	---

**KSCF18G COOL ZONE SERIES GAS FRYERS**  
**CHAPTER 7: TROUBLESHOOTING**

---

### 7.3 Filtration System Troubleshooting

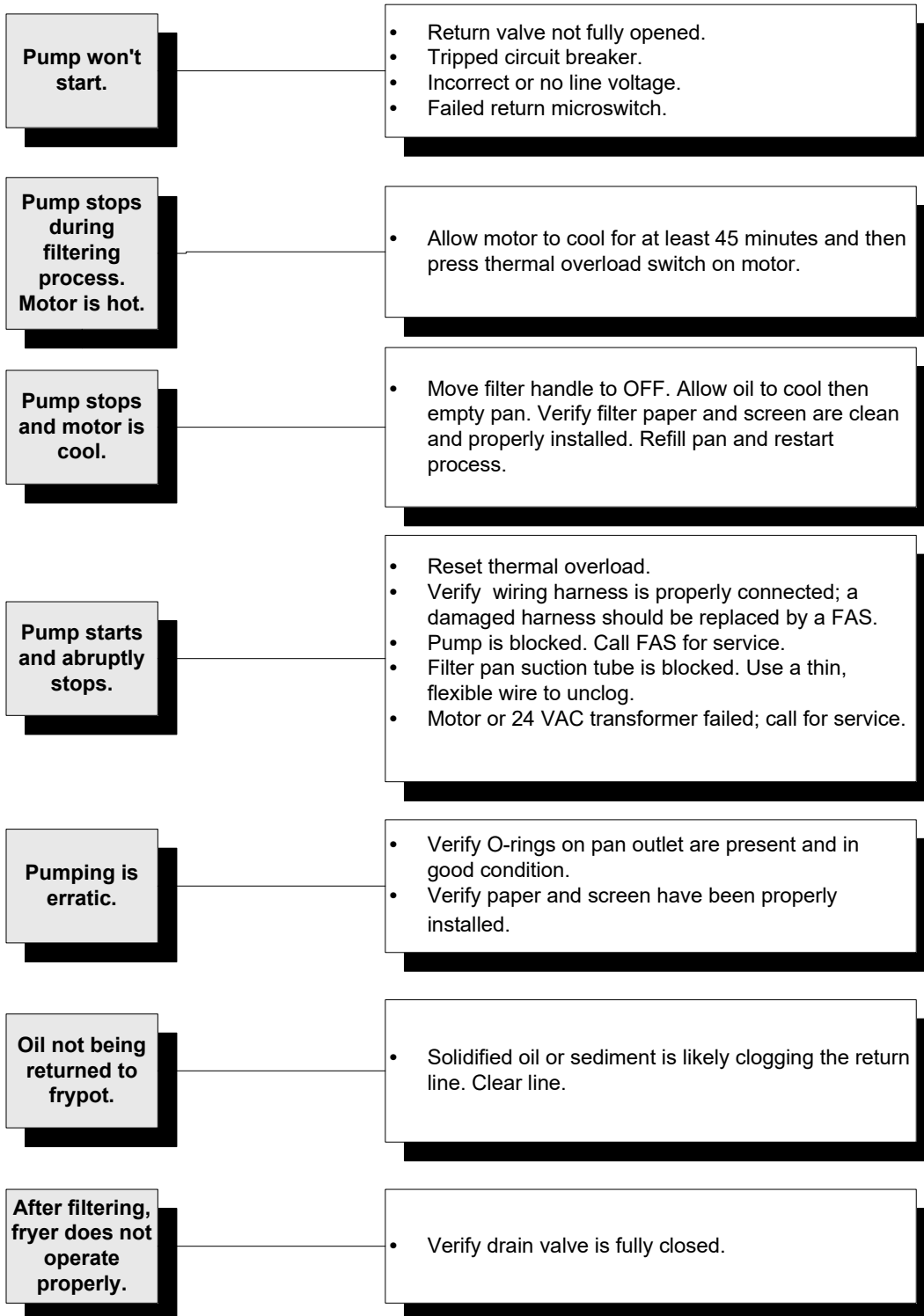

# KSCF18G COOL ZONE SERIES GAS FRYERS CHAPTER 7: TROUBLESHOOTING

## 7.4 Wiring Diagrams

### 7.4.1 Normally Open Float Switch (Right)

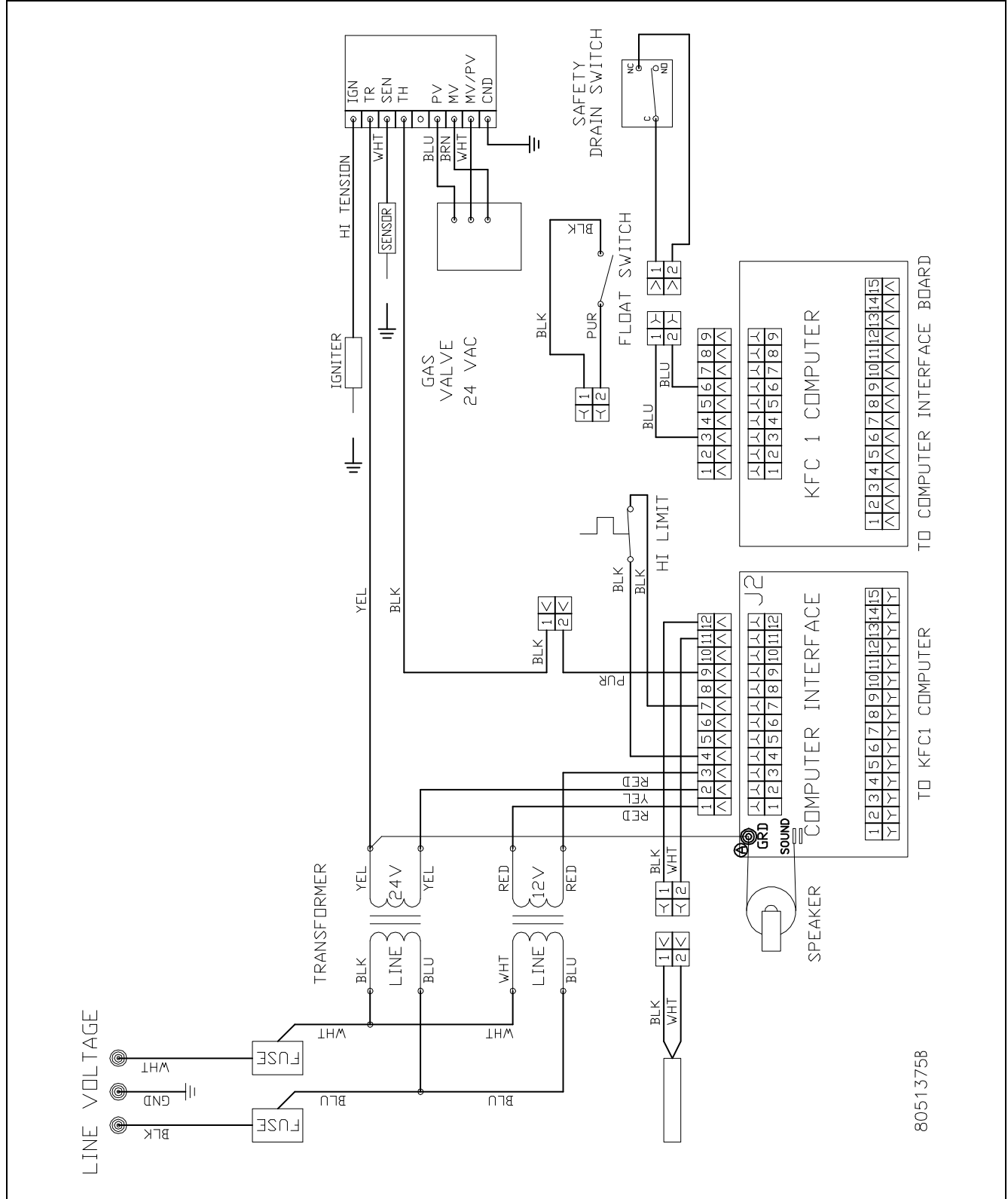

# KSCF18G COOL ZONE SERIES GAS FRYERS

## CHAPTER 7: TROUBLESHOOTING

### 7.4.2 Normally Open Float Switch (Left)

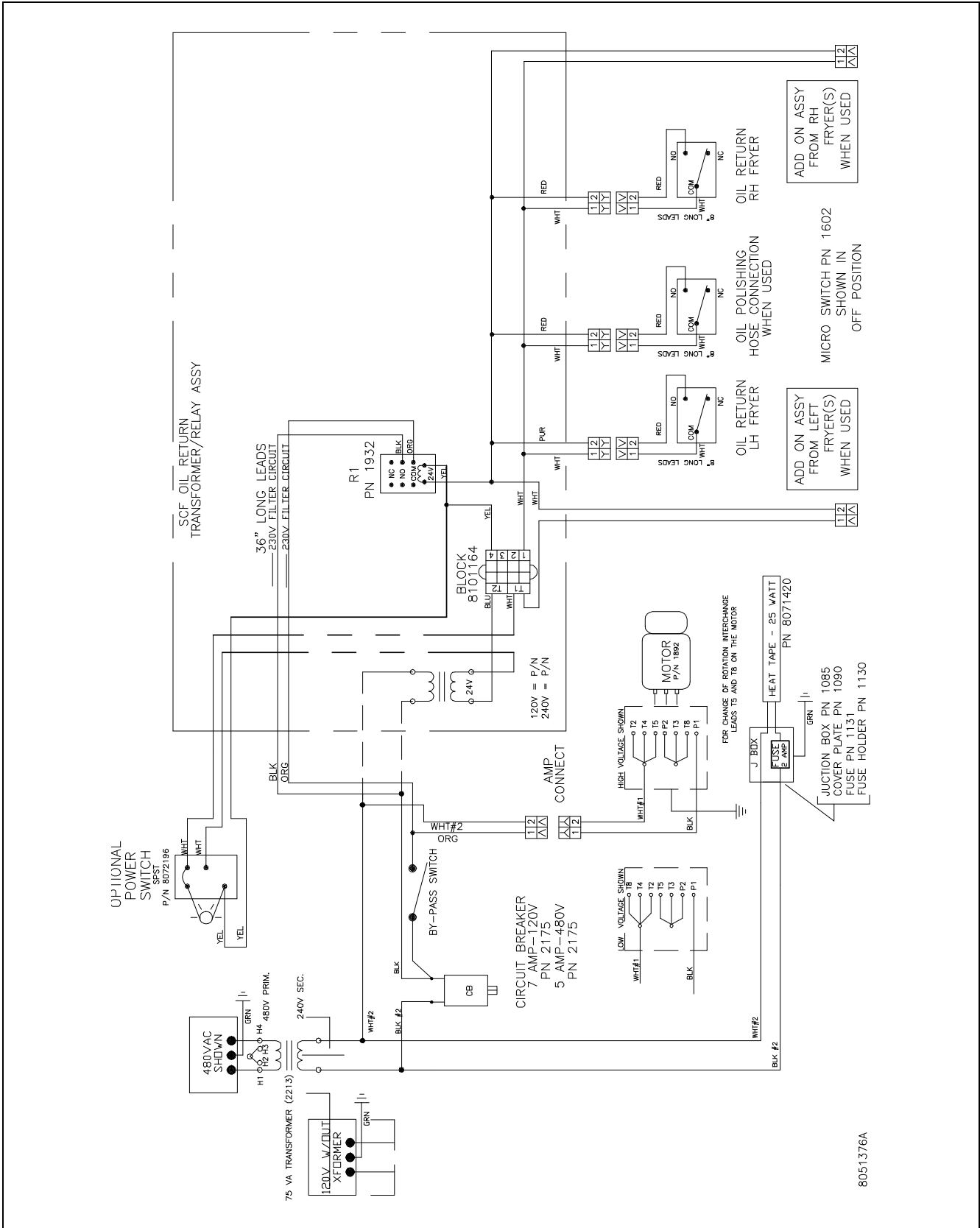

8051376A



# KSCF18G COOL ZONE SERIES GAS FRYERS

## CHAPTER 7: TROUBLESHOOTING

### 7.4.4 CE, Normally Open Float Switch (Left)

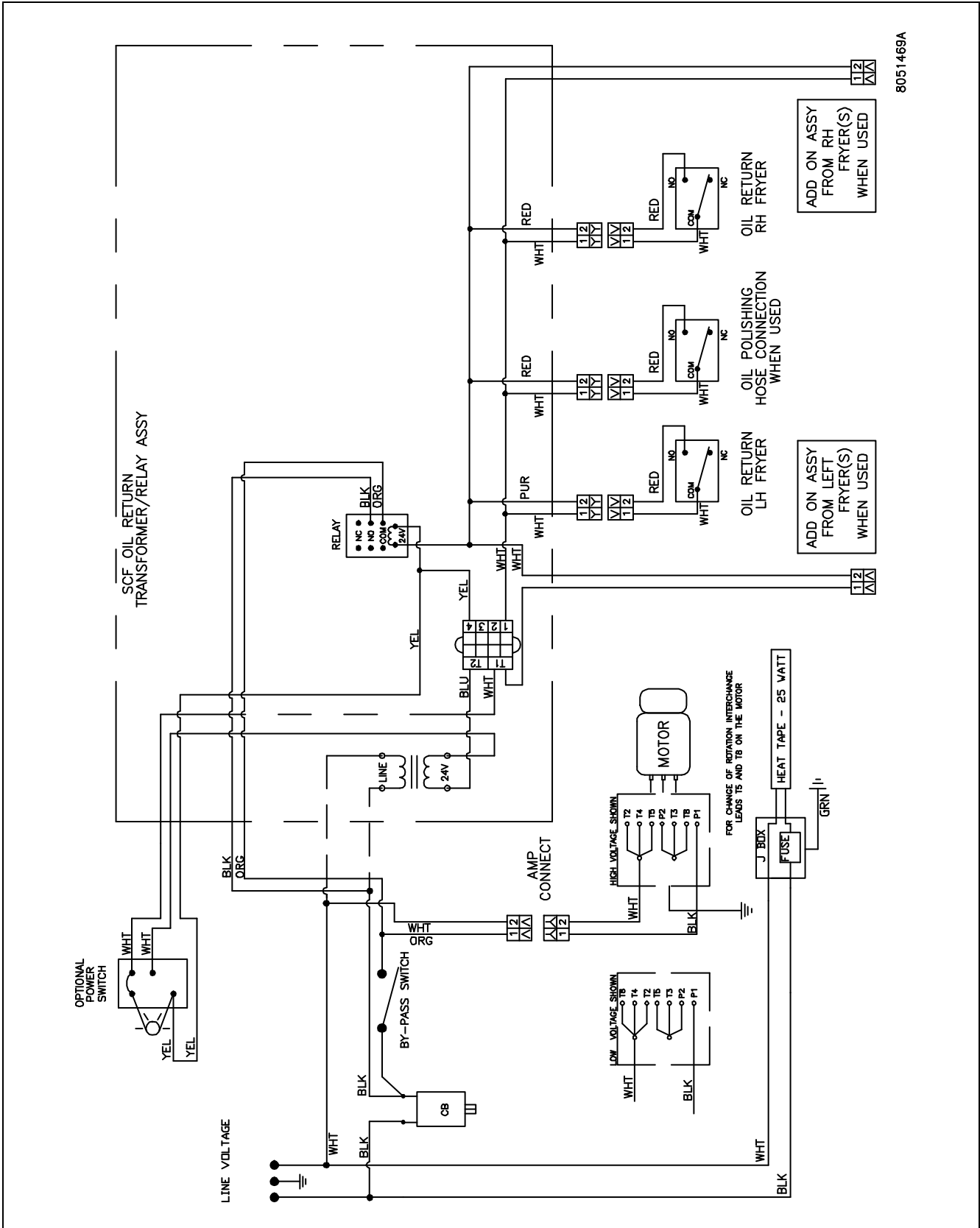

# KSCF18G COOL ZONE SERIES GAS FRYERS

## CHAPTER 7: TROUBLESHOOTING

### 7.4.5 Fast Ready 218G (KSCF218GP00001)

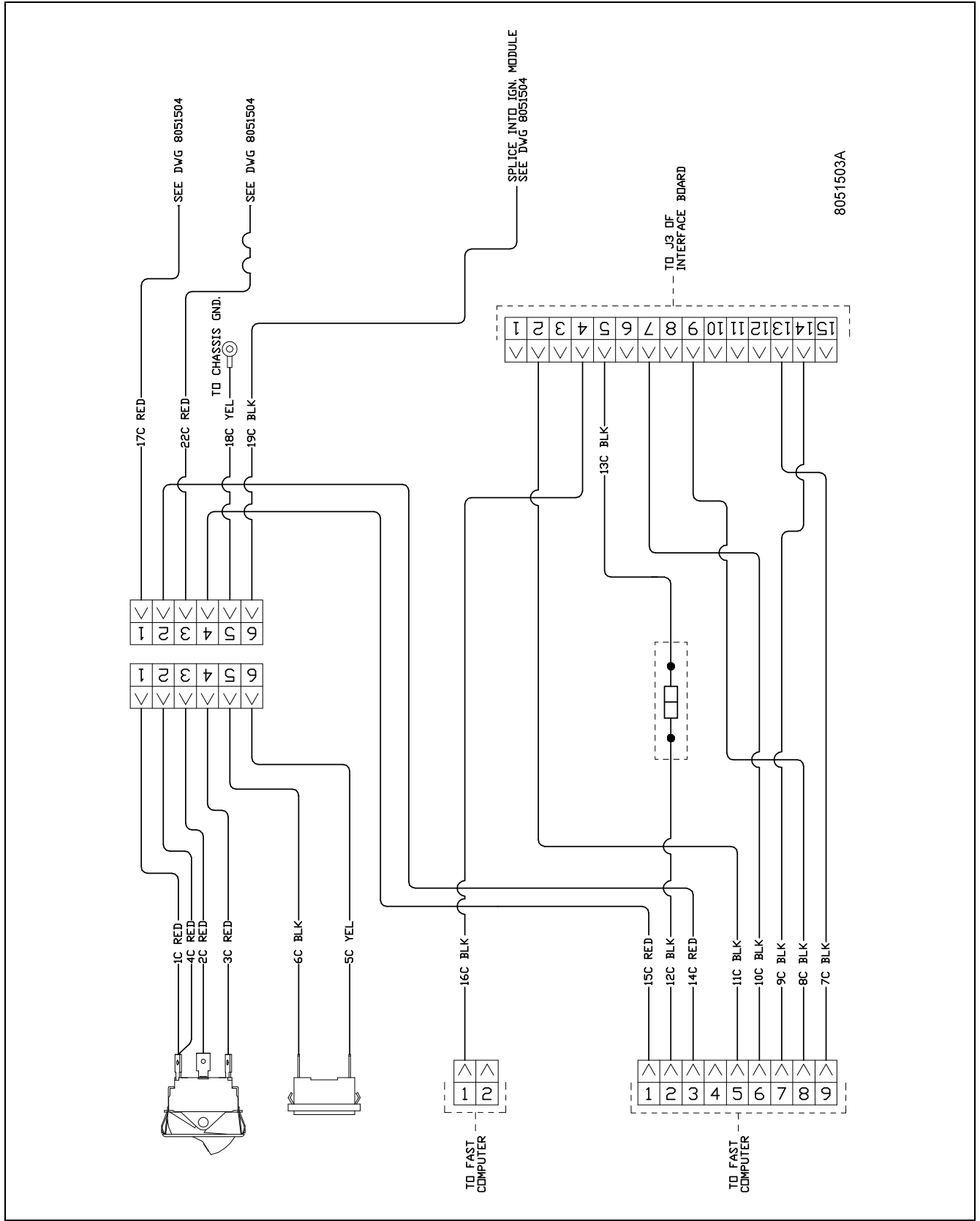

# KSCF18G COOL ZONE SERIES GAS FRYERS

## CHAPTER 7: TROUBLESHOOTING

### 7.4.6 Fast Ready 218G (KSCF218GP0001, KSCF218GN0007)

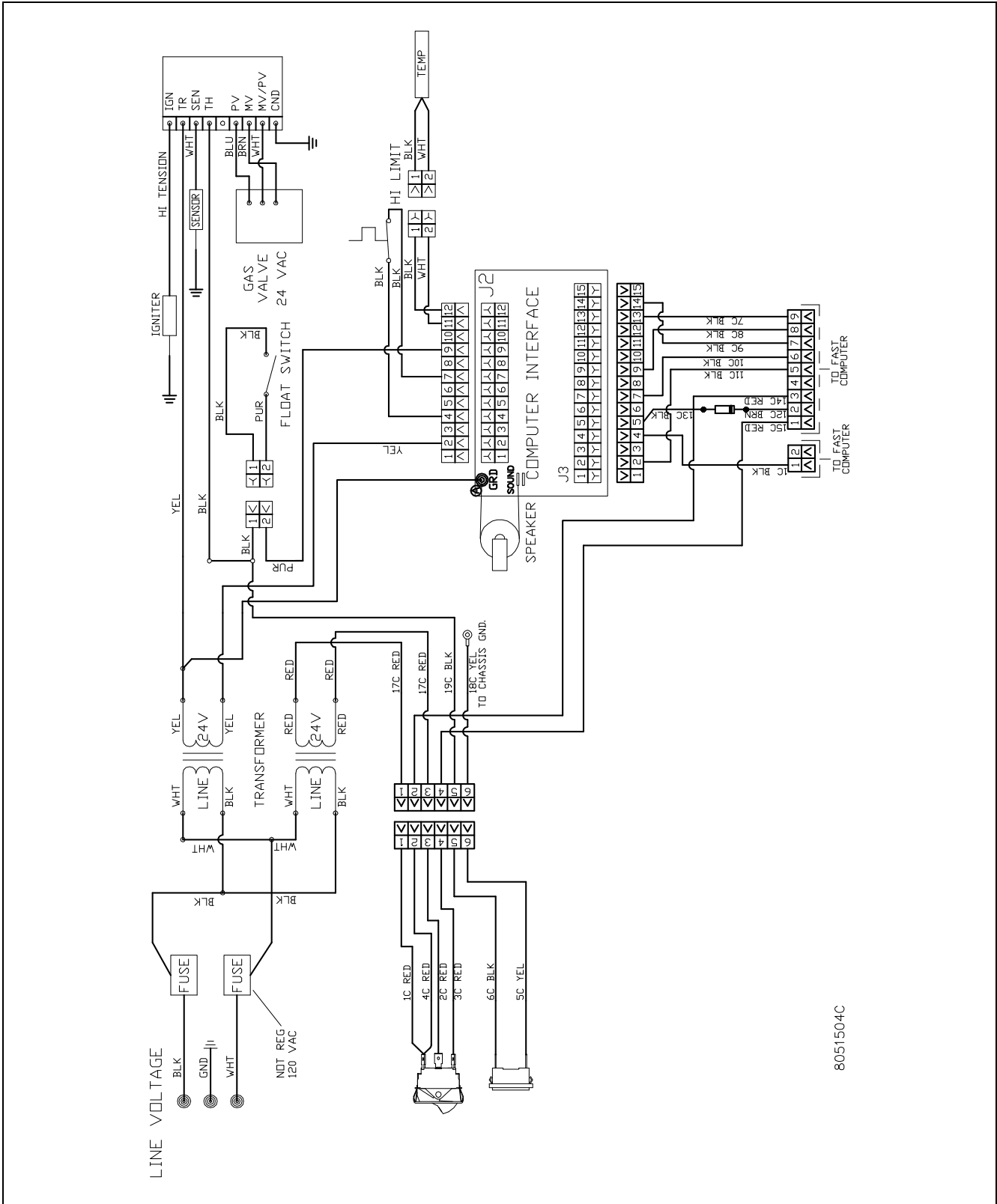

8051504C



# KSCF18G COOL ZONE SERIES GAS FRYERS

## CHAPTER 7: TROUBLESHOOTING

### 7.4.8 Constant Pilot, Fast Ready 218G

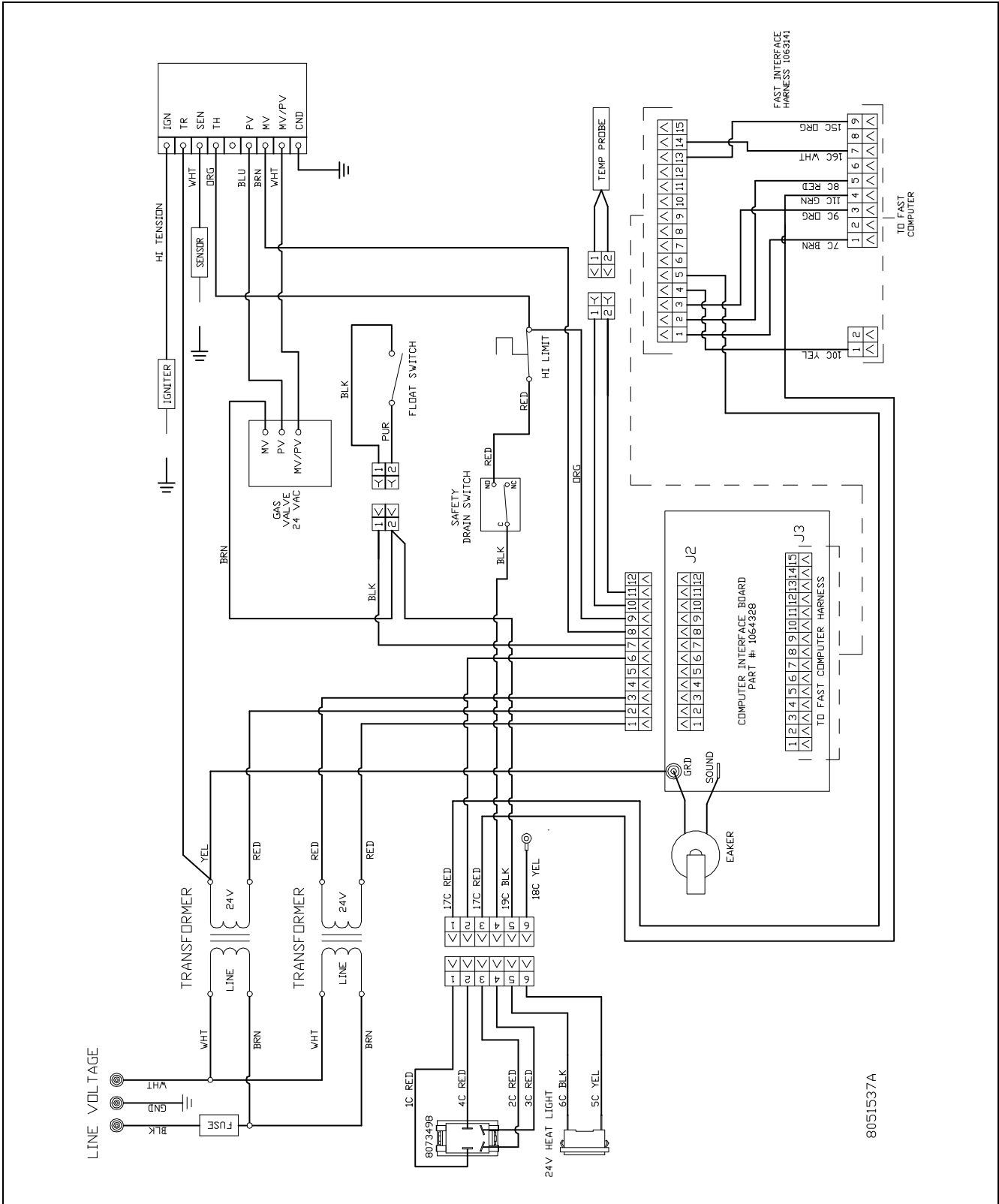

# KSCF18G COOL ZONE SERIES GAS FRYERS

## CHAPTER 7: TROUBLESHOOTING

### 7.4.9 Constant Pilot with KFC-1, 218G

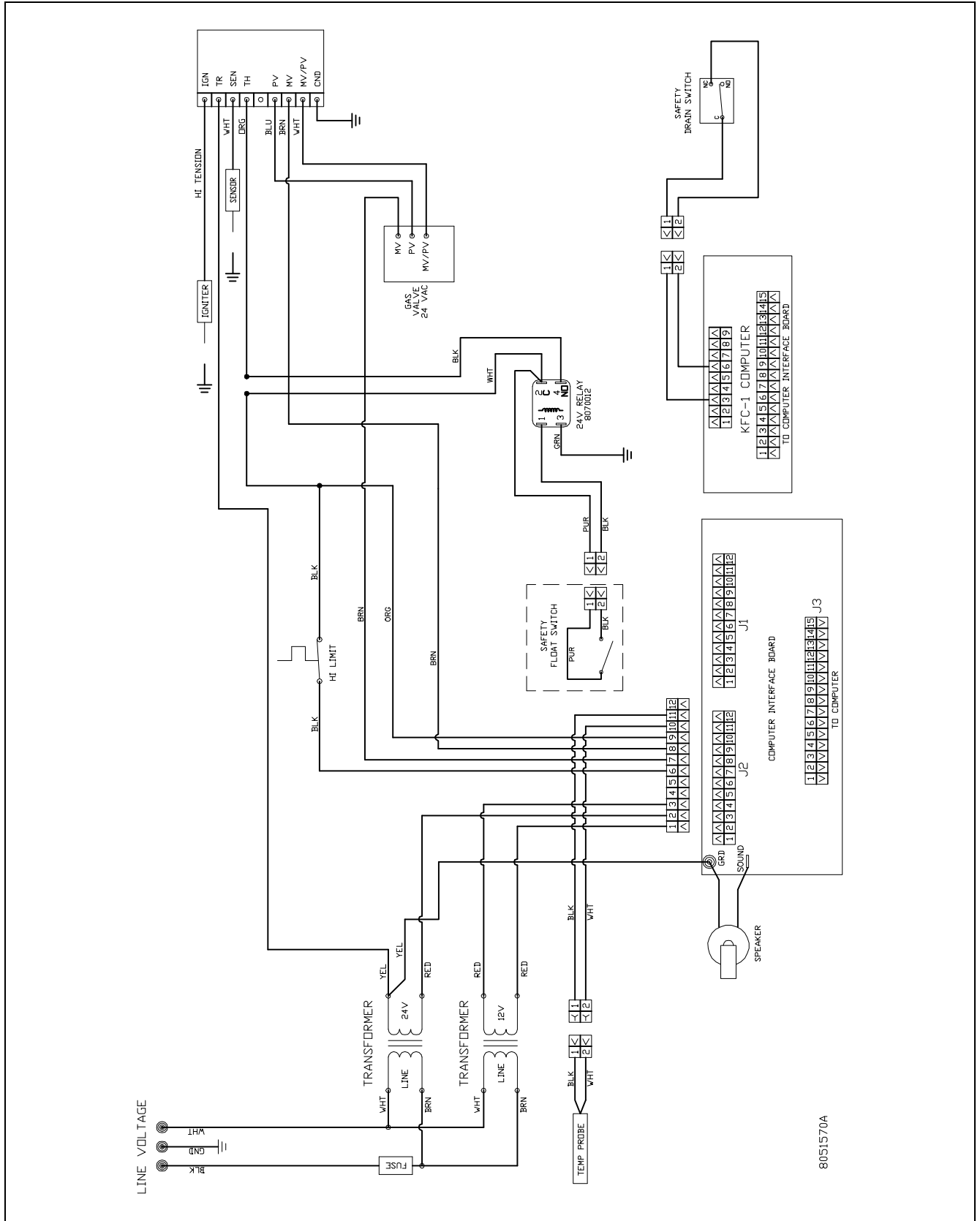

# KSCF18G COOL ZONE SERIES GAS FRYERS

## CHAPTER 7: TROUBLESHOOTING

### 7.4.10 Oil Return, 218G/318G (with Vent Solenoids)

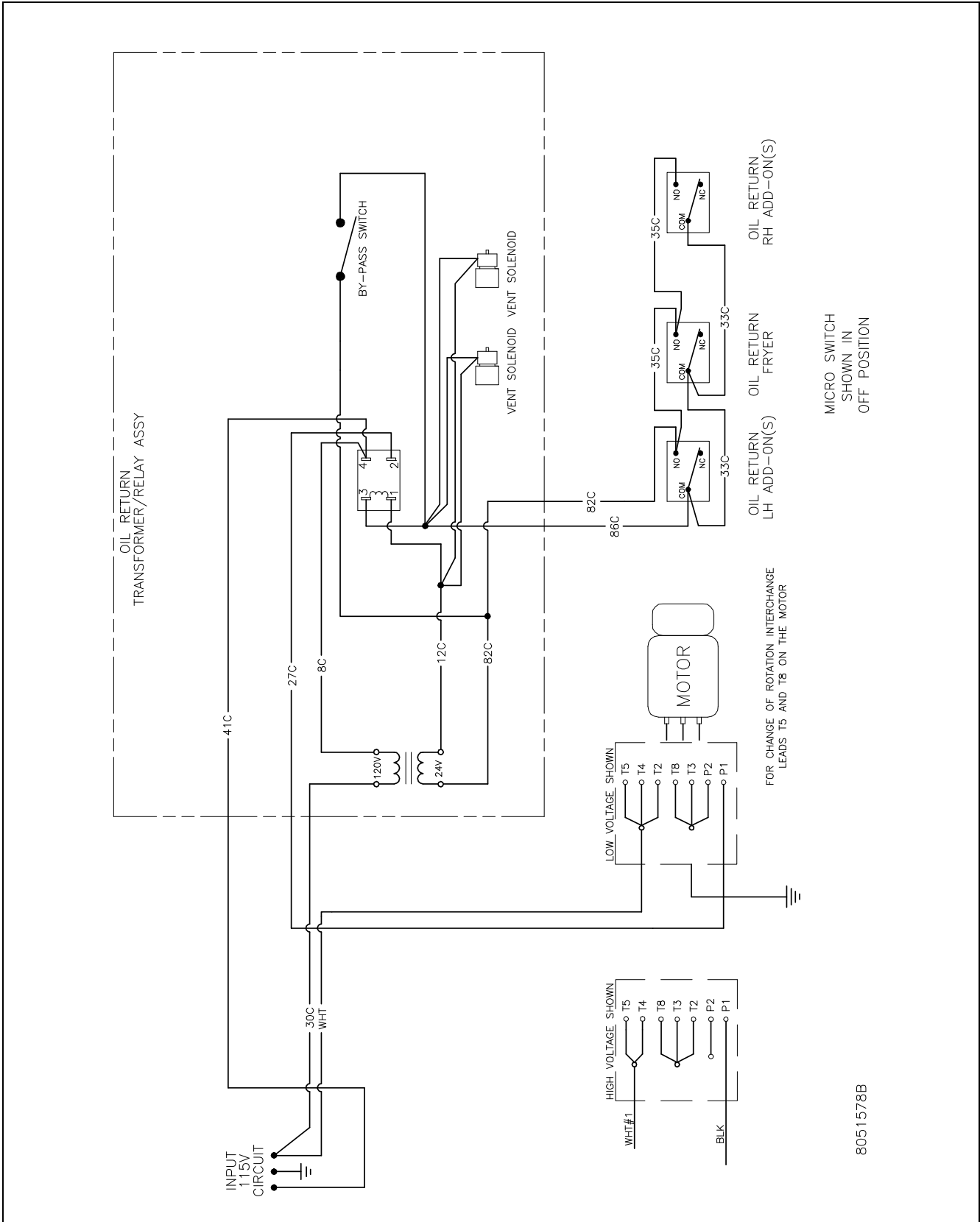

# KSCF18G COOL ZONE SERIES GAS FRYERS

## CHAPTER 7: TROUBLESHOOTING

### 7.4.11 CE, Single

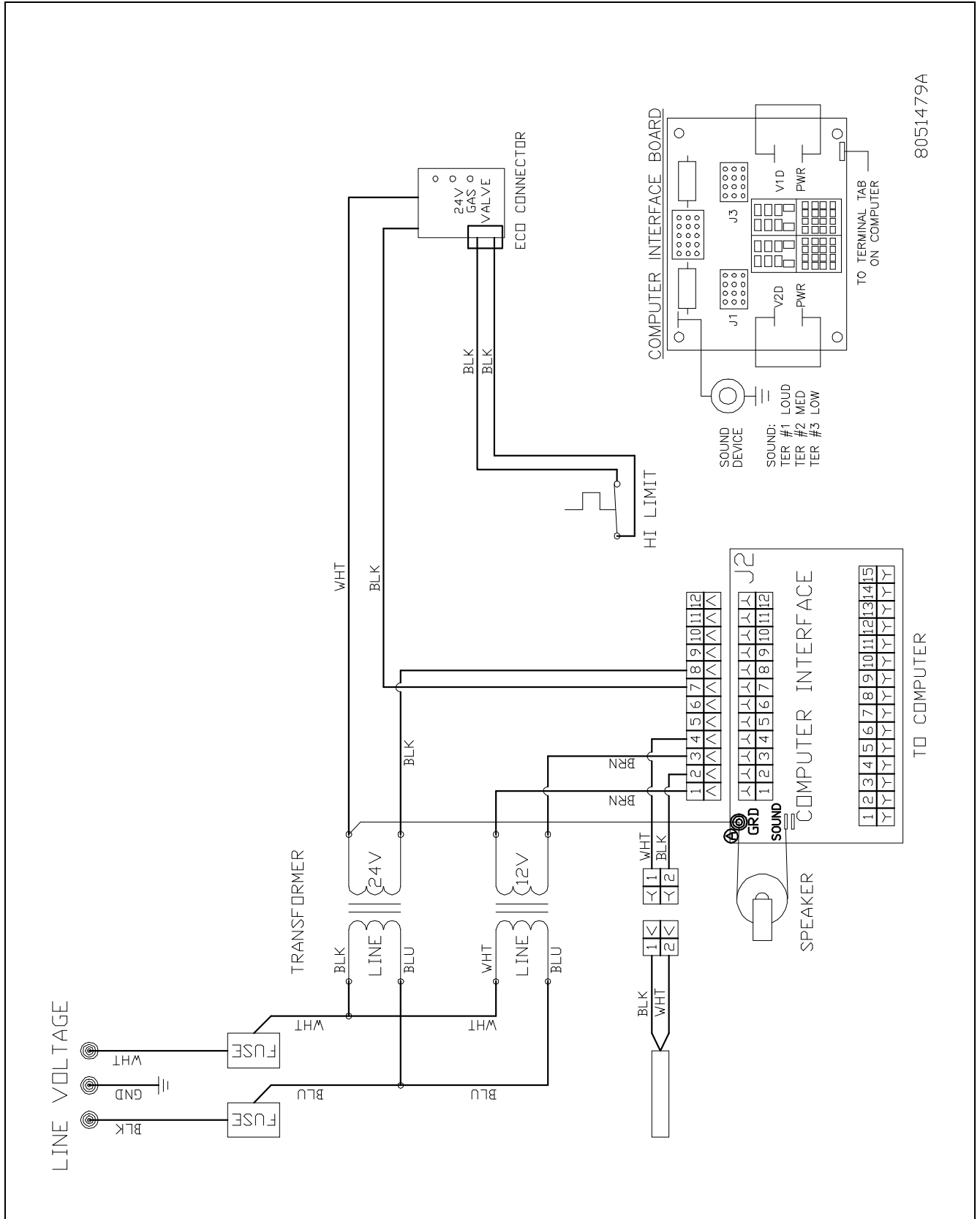

# KSCF18G COOL ZONE SERIES GAS FRYERS

## CHAPTER 7: TROUBLESHOOTING

### 7.4.12 Oil Return, Single

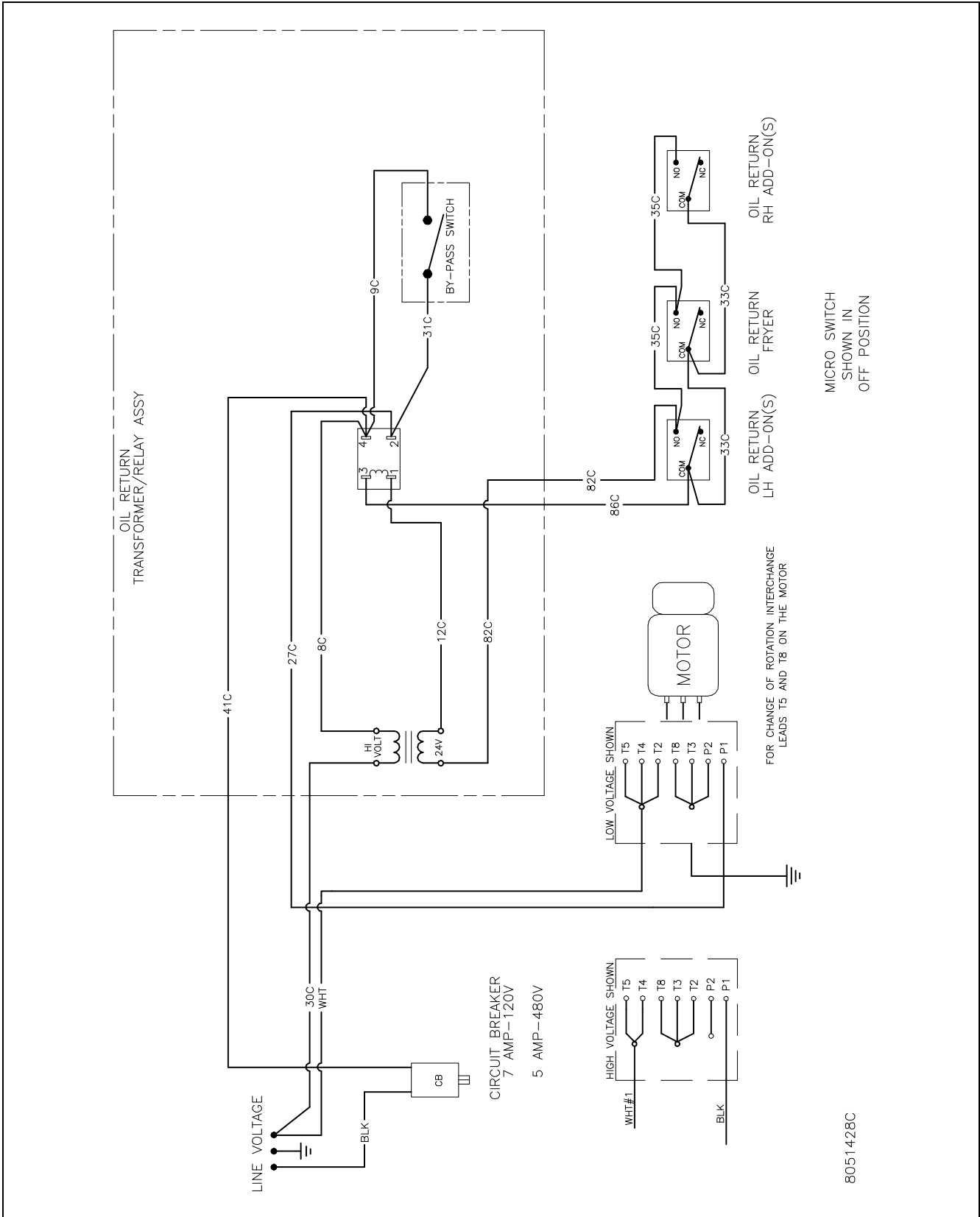

# KSCF18G COOL ZONE SERIES GAS FRYERS

## CHAPTER 7: TROUBLESHOOTING

### 7.4.13 Constant Pilot YCFHC118G with Fast

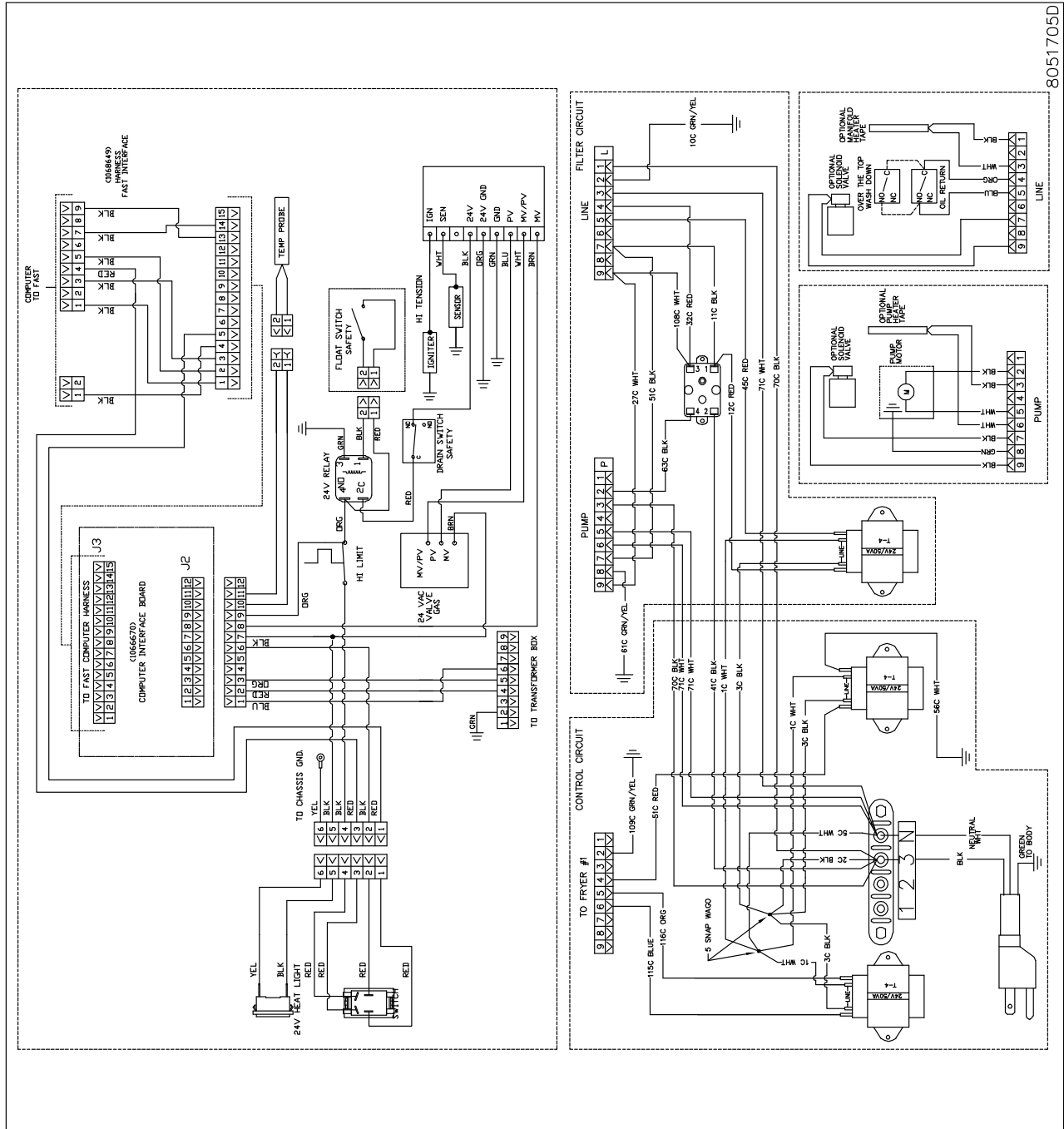

# KSCF18G COOL ZONE SERIES GAS FRYERS

## CHAPTER 8: PARTS LIST: DOUBLE & TRIPLE UNITS (218G/318G)

For parts and/or components not listed, contact the Frymaster Service Hotline at 1-800-551-8633 or 1-318-865-1711 for additional service and parts information.

### 8.1 Cabinetry and Related Components

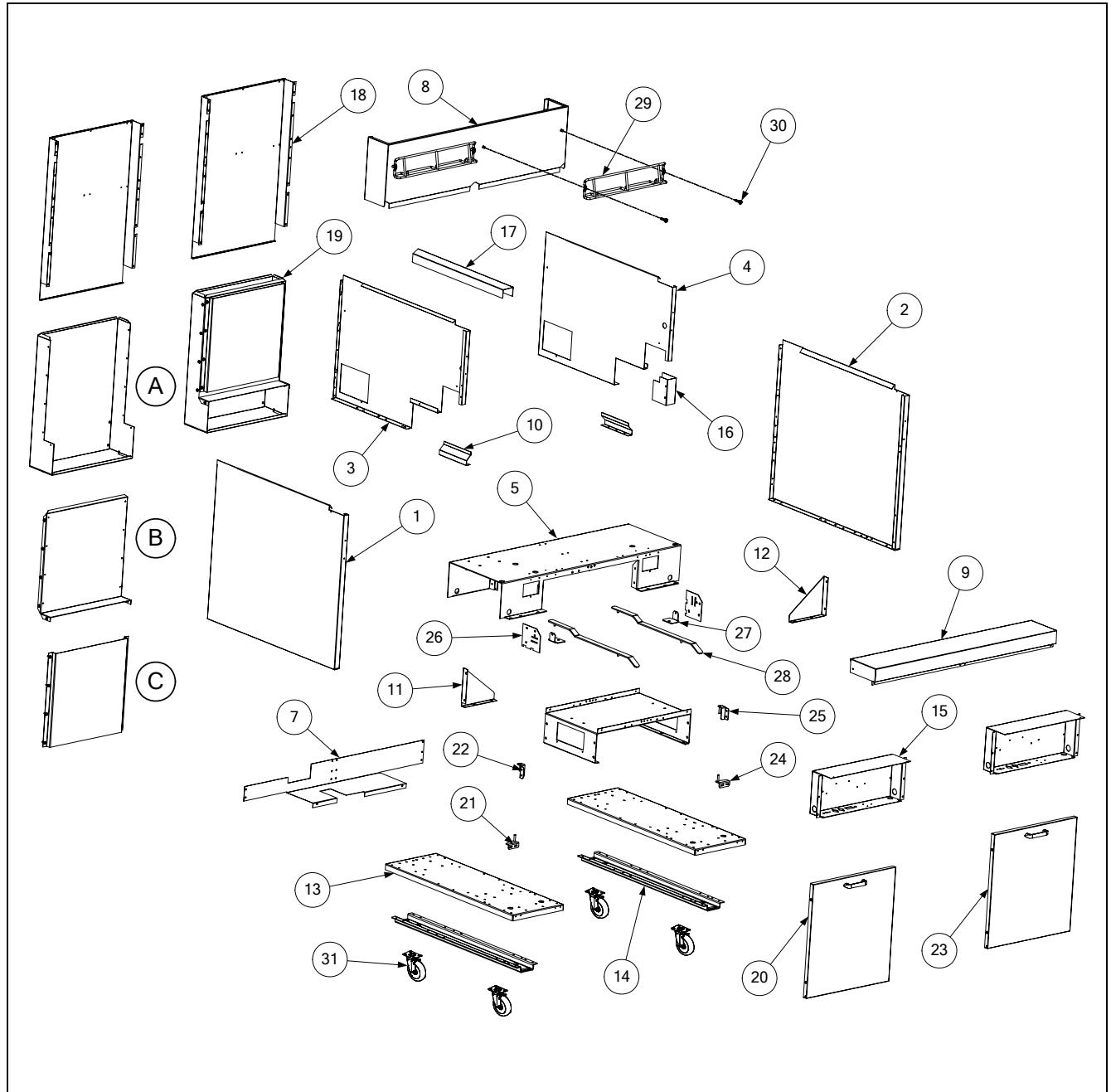

**KSCF18G COOL ZONE SERIES GAS FRYERS**  
**CHAPTER 8: PARTS LIST: DOUBLE & TRIPLE UNITS (218G/318G)**

**8.1 Cabinetry and Related Components (cont.)**

ITEM	PART #	COMPONENT
1	201-9081	Side, Cold Rolled Steel Cabinet, Left
2	202-9081	Side, Cold Rolled Steel Cabinet, Right
*	211-9606	Side, Stainless Steel Cabinet, Left
*	212-9606	Side, Stainless Steel Cabinet, Right
3	201-9080	Inner Panel, Left
4	202-9080	Inner Panel, Right
5	823-5256	Cabinet Base
6	200-8347	Plate, Base Frame
7	200-8985	Shield, Rear Cabinet
8	823-3366	Flue Cap
9	824-1466	Top Cap, Dual
*	210-6204	Marine Edge, Dual
10	200-9043	Cover, Inner Panels
11	201-9688	Gusset, Side Panel, Left
12	202-9688	Gusset, Side Panel, Right
13	824-1560	Channel, Base
14	823-4064	Channel, Leg Support
15	824-1465	Panel, Wireway
16	200-8182	Post, Door
17	210-1288	Joiner Strip
18	200-5036	Back, Cabinet
19	106-0997	Flue Assembly
A	200-1773	Back, Flue
B	200-1339	Front, Flue
C	200-1325	Shield, Flue Heat
20	106-4331	Door Assembly, Left
21	823-5051	Hinge, Lower, Left
22	823-5061	Hinge, Upper, Left
23	106-4332	Door Assembly, Right
24	823-5052	Hinge, Lower, Right
25	823-5062	Hinge, Upper, Right
*	810-0066	Magnetic Catch, Door
*	810-0180	Handle, Door
26	200-2713	Plate, Suction Manifold
27	210-1180	Insert, Suction Manifold
28	823-3347	Frame, Slide Base
29	810-2794	Basket Hanger
30	809-0171	Thumbscrew, Basket Hanger
31	810-0356	Caster, 5" ( <i>without brake</i> )
*	810-0357	Caster, 5" ( <i>with brake</i> )
*	810-1205	Leg, 6"
*	200-1183	Crisper Tray without Handles

\* Not illustrated.

**KSCF18G COOL ZONE SERIES GAS FRYERS  
CHAPTER 8: PARTS LIST: DOUBLE & TRIPLE UNITS (218G/318G)**

**8.2 Accessories**

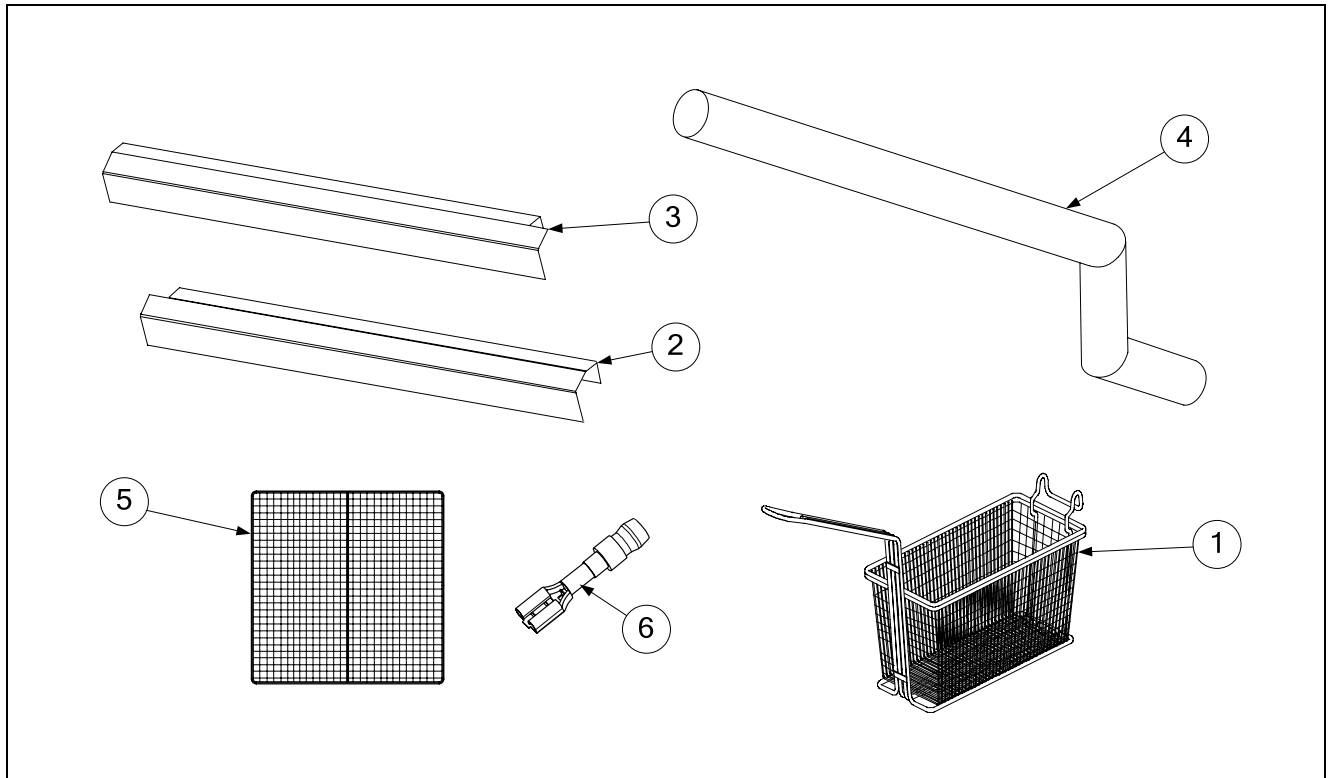

ITEM	PART #	COMPONENT
1	803-0306	Twin Fry Basket
2	211-8178	Joiner Strip (to mount unit to the left of a 2424G)
3	212-8178	Joiner Strip (to mount unit to the right of a 2424G)
4	823-5404	Drain Tube (to attach unit drain to a 2424G)
5	803-0149	Basket Support Screen
*	810-2235	Basket Support Grid
6	807-3484	Rajah Connector (included in module kit, P/N 826-2117)
*	803-0293	Gloves, Neoprene (pair)
*	803-0197	Fryer's Friend
*	803-0278	Brush, L-shaped

\* Not illustrated.

**KSCF18G COOL ZONE SERIES GAS FRYERS**  
**CHAPTER 8: PARTS LIST: DOUBLE & TRIPLE UNITS (218G/318G)**

**8.3 Component Box, Computers, and Related Components**

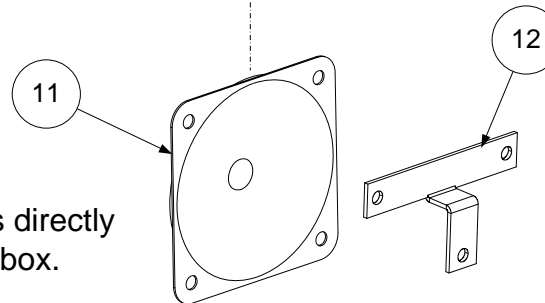
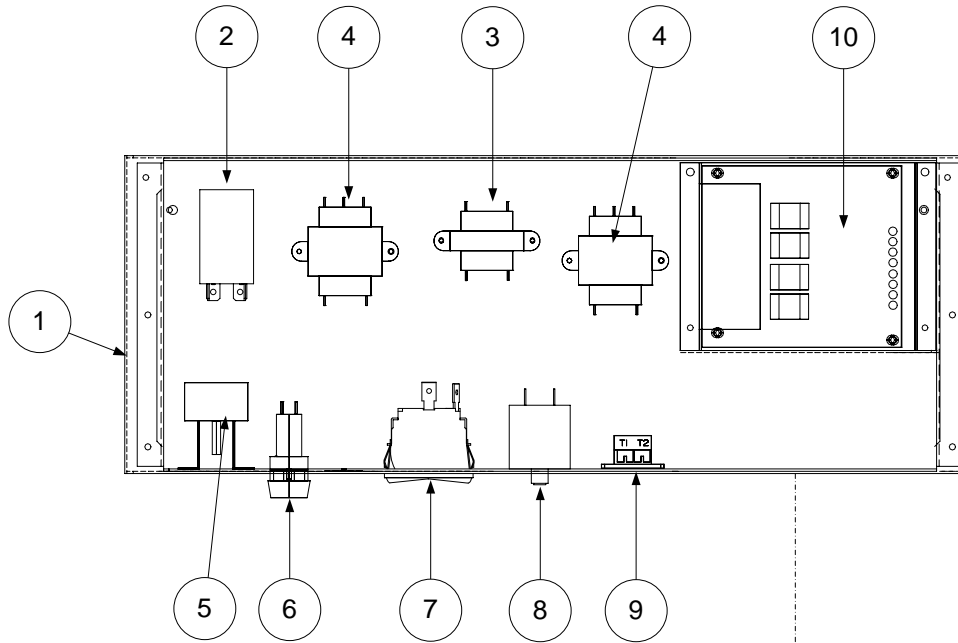

Speaker mounts directly into component box.

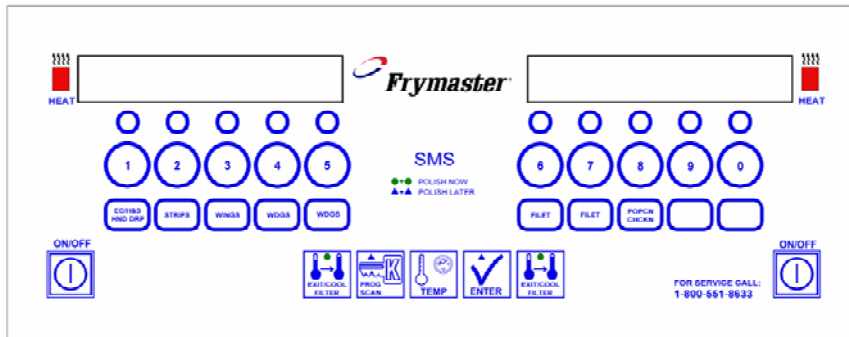

13

**KSCF18G COOL ZONE SERIES GAS FRYERS**  
**CHAPTER 8: PARTS LIST: DOUBLE & TRIPLE UNITS (218G/318G)**

**8.3 Component Box, Computers, and Related Components (cont.)**

ITEM	PART #	COMPONENT
1	824-1465	Component Box
2	807-4114	Relay, DPDT, 24VAC
*	106-1414	Relay Socket
*	807-3613	Relay Spring
*	200-1337	Relay Bracket with 1 cutout
3	807-0855	Transformer, 120V to 12V
4	807-0800	Transformer, 120V to 24V (Fryer and Filter Circuit)
*	807-0680	Transformer, 240V to 24V
*	807-1999	Transformer, Dual Voltage (CE only)
5	▶▶▶	<b>See Page 8-10 for High-Limit Thermostats</b>
6	807-0922	Holder, Buss Fuse
*	807-3592	Fuse, 2 Amp Slow Blow
7	807-3580	Switch, Filter By-pass Rocker
*	807-3620	Switch, Filter By-pass Toggle (older units)
8	807-3577	Circuit Breaker, Filter, 7 Amp (120V units)
*	807-3538	Circuit Breaker, Filter, 5 Amp (208/230V units)
9	810-1164	Block, Terminal
10	106-6669	Interface Board, Standing Pilot, SMT
*	826-2256	Interface Board, Electronic Ignition, SMT
*	106-6670	Interface Board, Fast Ready, Standing Pilot, SMT
*	106-6671	Interface Board, Fast Ready, No Basket Lift, SMT
*	106-4971	Plate, Mounting, Interface Board
11	807-3520	Speaker, Sound Device
*	807-4330	SMT Adapter, Sound Device
12	200-2052	Bracket, Speaker
*	807-3546	Bushing, Heyco
*	809-0360	Screw, #8 x 3/8" Type B Hex Washer
*	809-0766	Nut, 10-32 Hex Head
13	806-9727	KFC-1 Computer
*	823-2882	Panel, Control - Computer
*	809-0824	Screw, Control Panel
*	826-2117	Spark Module Kit (includes rajah adapter, P/N 807-3484)
*	819-5733	KFC-1 SMS User's Guide

\* Not illustrated.

**KSCF18G COOL ZONE SERIES GAS FRYERS**  
**CHAPTER 8: PARTS LIST: DOUBLE & TRIPLE UNITS (218G/318G)**

**8.4 Drain Valve, Oil Return, and Related Components**

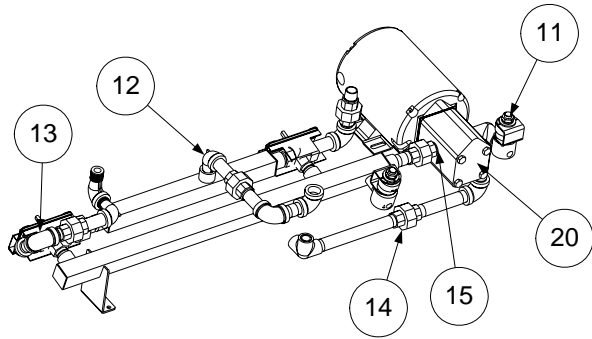

**Oil Return Valves, Fittings, and Components  
(106-4717)**

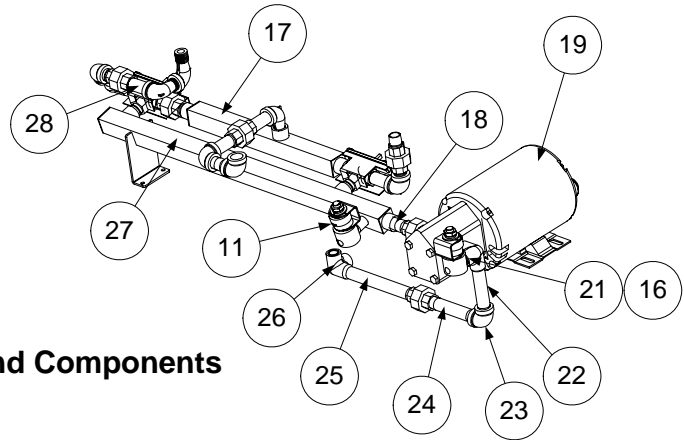

**Drain Valve Assembly  
(106-4672)**

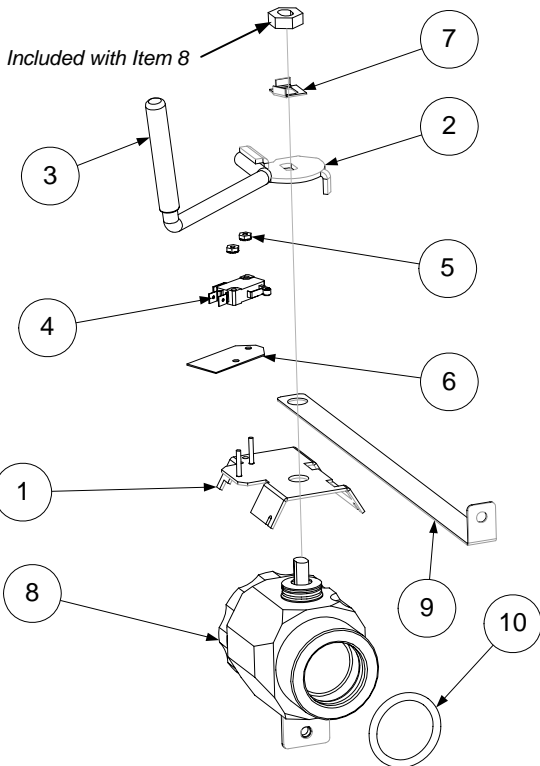

**3-Way Valve Assembly  
(Item 13 above, 106-4763)**

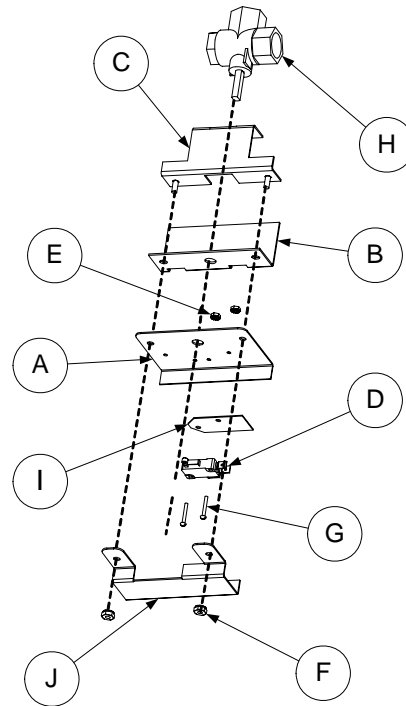

**KSCF18G COOL ZONE SERIES GAS FRYERS**  
**CHAPTER 8: PARTS LIST: DOUBLE & TRIPLE UNITS (218G/318G)**

**8.4 Drain Valve, Oil Return, and Related Components (cont.)**

ITEM	PART #	COMPONENT
	106-4672	<b>Drain Valve and Microswitch Components</b>
1	106-1401	Bracket, Microswitch
2	210-9374	Bracket, Activator- Microswitch
3	200-9345	Handle, Drain Valve
*	823-5181	Handle, Push/Pull
*	816-0547	Cap, Vinyl Red
4	807-2104	Microswitch
5	826-1366	Nut, 4-40 Keps Hex with Extension Teeth (pkg. of 25)
6	816-0220	Insulation, Microswitch
7	200-1257	Retainer, Drain Valve Nut
8	823-5053	Drain Valve, 1½" Full Port (With Washers, Support, & Nut)
9	200-8796	Bracket, Drain
10	816-0544	O-Ring, Seal
*	810-0697	Disconnect, Male
	106-4717	<b>Oil Return Valve, Fittings, and Components</b>
11	807-2484	Valve, Solenoid, ¼"
12	813-0165	Elbow, ½" x ½ NPT 90°
13	106-4763	<b>3-Way Valve Assembly</b>
A	210-9917	Support, Microswitch Mount
B	210-9918	Brace, 3-Way Bottom
C	106-5229	Support, Oil Return Valve
D	807-2104	Switch, Micro-roller Lever
E	826-1366	Nut, 4-40 Keps Hex with Extension Teeth (pkg. of 25)
F	826-1376	Nut, Keps, 10-32 Hex (pkg. of 10)
G	826-1359	Screw, 4-40 x ¾" Round Head (pkg. of 25)
H	810-1003	Valve, 180 ° 3-Way Ball
I	816-0220	Insulation, Microswitch
J	210-9915	Cover, Oil Return Microswitch
K	200-1143	Retainer, Oil Return Valve Nut
L	809-0056	Nut, 5/16-24 Hex Nylon Locking
14	813-0173	Union, ½" NPT, BM
15	813-0022	Nipple, ½" x Close NPT BM
16	813-0304	Bushing, ½" x ¼" BM Flush
17	823-5183	Tubing, Front
18	813-0298	Nipple, ½" x 2.00" NPT BM Pipe
19	826-1712	Motor, Filter Pump, 115V, 60 Hz, Baldor
20	810-3071	Pump, 8GPM, Filter
*	810-2252	Pump, 5GPM, Filter
*	816-0093	Gasket, Pump/Motor
20	813-0016	Nipple, ⅛" NPT Close BM
22	813-0093	Nipple, ½" x 4.00" NPT BM
23	813-0062	Elbow, ½" 90° BM
24	813-0251	Nipple, ½" x 4.5" NPT BM Pipe
25	813-0099	Nipple, ½" x 7.0" NPT BM Pipe
26	813-0331	Elbow with Side Outlet, ½" NPT
27	823-5184	Tubing, Rear
28	813-0265	Nipple, ½" x 2.5" NPT BM
*	106-2387	Heater Tape Assembly, 36", 120V, 25W

\* Not illustrated.

**KSCF18G COOL ZONE SERIES GAS FRYERS  
CHAPTER 8: PARTS LIST: DOUBLE & TRIPLE UNITS (218G/318G)**

**8.5 Drain System**

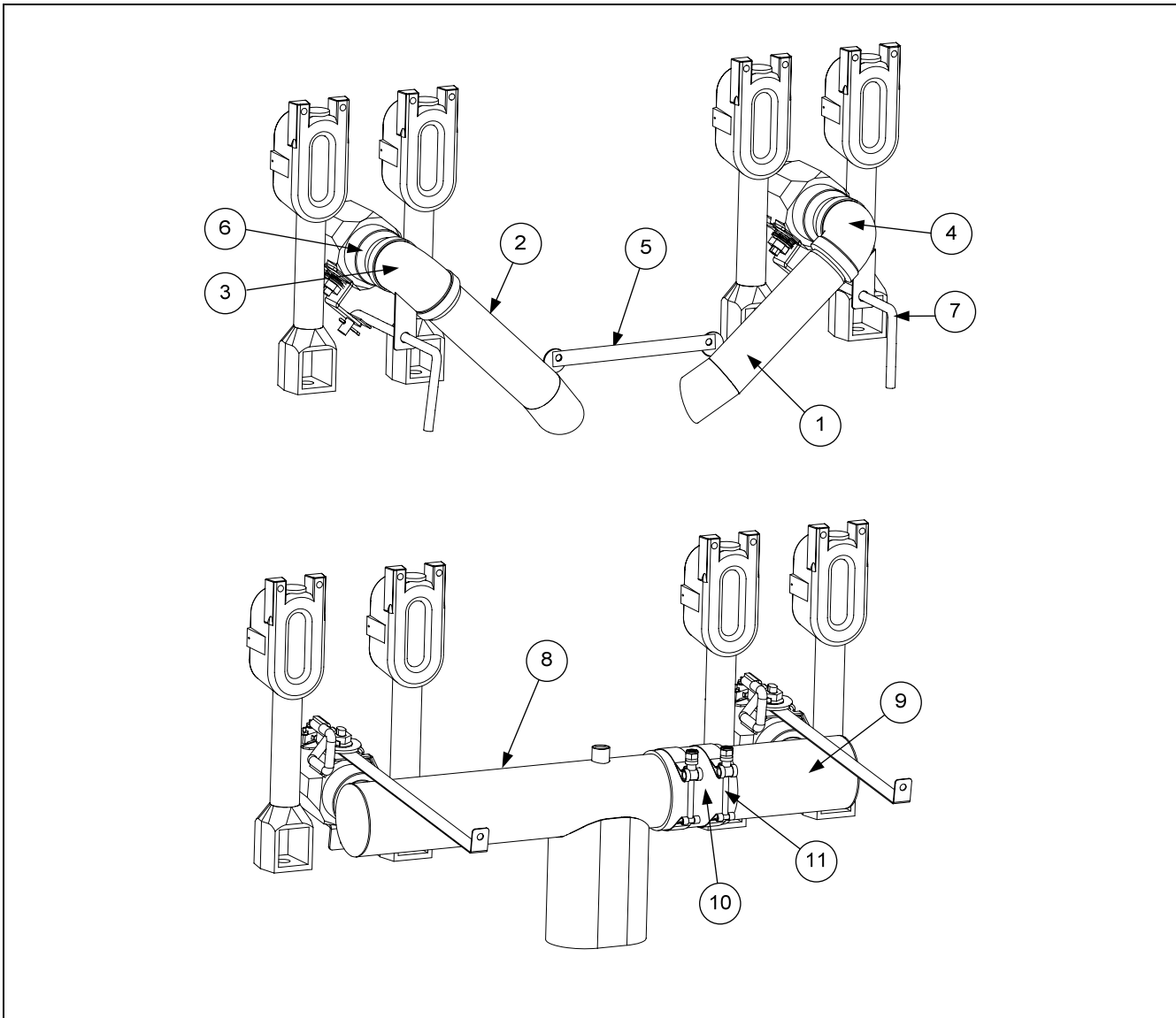

ITEM	PART #	COMPONENT
<b>1.5" Drain System (previous style)</b>		
1	823-3358	Pipe, Drain Right
2	823-3357	Pipe, Drain Left
3	823-3221	Elbow, Bracket, Left
4	823-3222	Elbow, Bracket, Right
5	210-2311	Clamp, Drain Pipe, Center
6	813-0687	Nipple, 1.5" NPT x Close
7	823-3440	Handle, Drain, Push/Pull
<b>3" Drain System (current style)</b>		
8	823-5180	Tube, Oval Dump
9	823-4950	Tube, Drain Right
10	816-0729	Sleeve, Drain Connector
11	809-0969	Clamp, T-bolt

**KSCF18G COOL ZONE SERIES GAS FRYERS**  
**CHAPTER 8: PARTS LIST: DOUBLE & TRIPLE UNITS (218G/318G)**

**8.6 Filter Pan and Related Components**

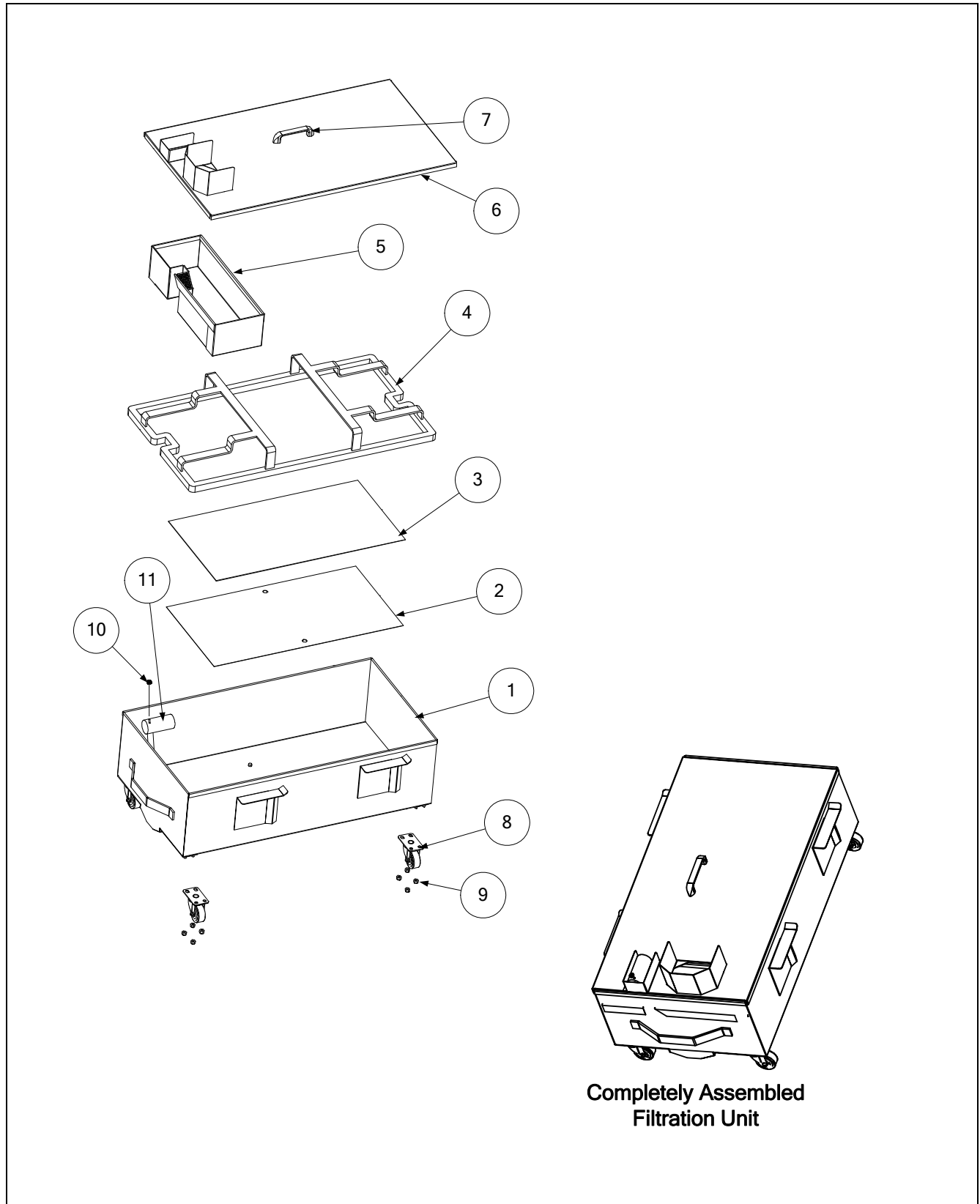

**KSCF18G COOL ZONE SERIES GAS FRYERS**  
**CHAPTER 8: PARTS LIST: DOUBLE & TRIPLE UNITS (218G/318G)**

---

**8.6 Filter Pan and Related Components (cont.)**

ITEM	PART #	COMPONENT
		<b>Filter Pan Assembly</b>
1	823-5214	Pan, Filter
2	106-7330	Screen, Filter
3	803-0299	Paper, Filter
4	810-2911	Ring, Hold-Down
5	823-4832	Crumb Basket
6	106-4693	Lid, Filter Pan
7	810-0180	Handle, Filter Pan Lid
8	810-2805	Caster, 2" Filter Pan
9	809-0823	Nut, ¼ x 20 Nylock
10	813-0568	Plug, ⅜" Socket-head Pipe
11	823-4839	Nipple, Suction
		<b>Other Components</b>
*	803-0278	Teflon Brush
*	803-0002	Filter Powder

\* Not illustrated.

**KSCF18G COOL ZONE SERIES GAS FRYERS**  
**CHAPTER 8: PARTS LIST: DOUBLE & TRIPLE UNITS (218G/318G)**

**8.7 Frypot and Related Components**

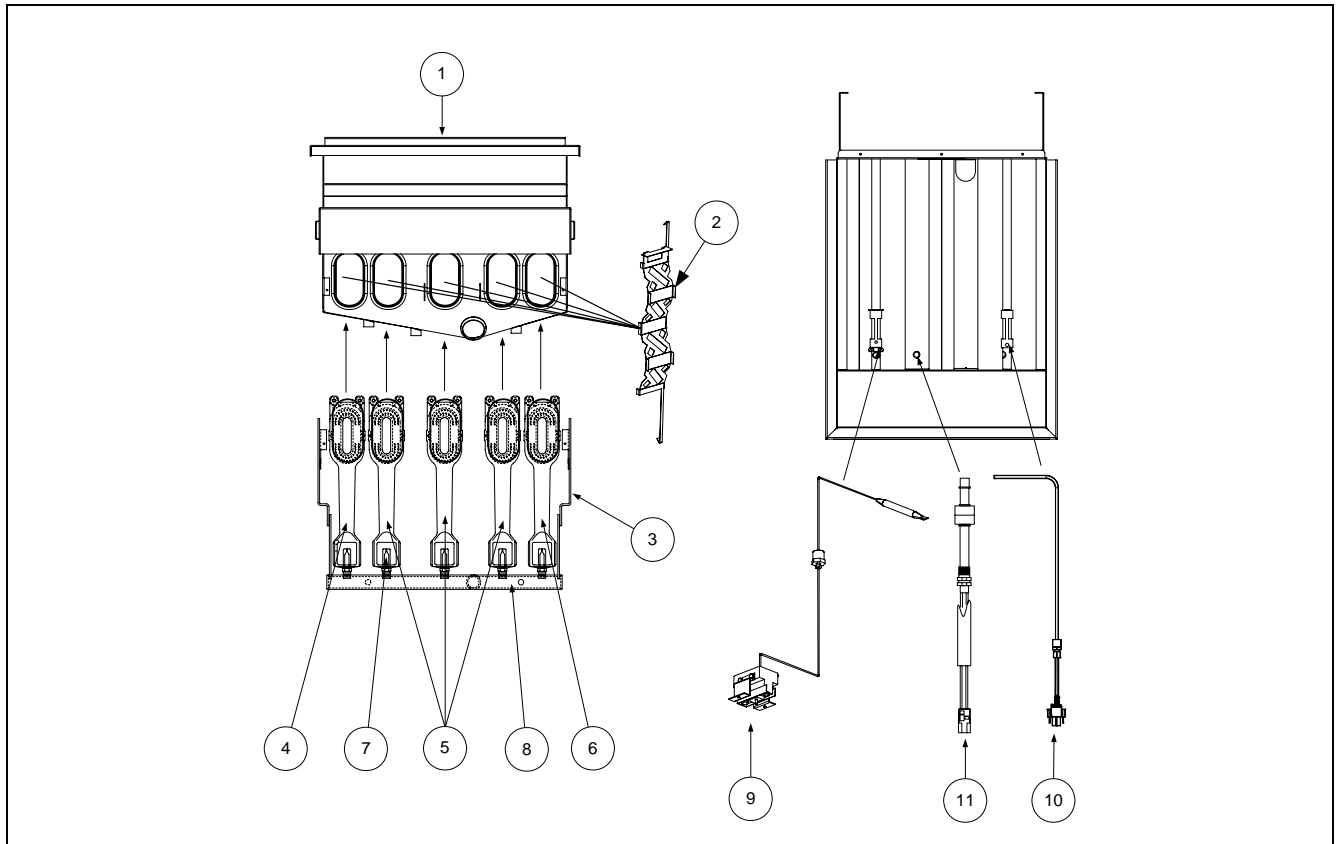

ITEM	PART #	COMPONENT
1	823-4884	Frypot, Stainless Steel, with 1/2" Drain
*	803-0149	Grid, Frypot
2	210-8387	Diffuser Assembly
3	200-1615	Support, Manifold
4	810-2151	Burner, Left
5	810-2149	Burner, Center
6	810-2150	Burner, Right
*	200-3081	Shutter, Air (CE only)
7	810-2062	Orifice, 2.58 mm (#38)
*	810-2048	Orifice, 2.53 mm (#39) (Non-CE)
*	810-2060	Orifice, 2.40 mm (#42) (CE-blue)
*	810-2059	Orifice, 1.51 mm (#53) (Non-CE & CE-red)
*	810-2497	Orifice, 1.32 mm (#55) (LP)
*	810-2365	Orifice, 1.19 mm (#56) (LP)
*	810-2600	Orifice, 4.22 mm (#19) (MFG)
8	810-2072	Manifold, Gas
9	807-3680	High-Limit with Manual Reset - 450°F (232°C)
*	807-3560	High-Limit with Manual Reset - 410°F (210°C)
*	210-1433	High-Limit Bracket
10	106-1424	Temperature Probe
11	826-2146	Float Switch Kit

\* Not illustrated.

**KSCF18G COOL ZONE SERIES GAS FRYERS**  
**CHAPTER 8: PARTS LIST: DOUBLE & TRIPLE UNITS (218G/318G)**

**8.8 Gas Valves, Pilot Assemblies, and Related Components**

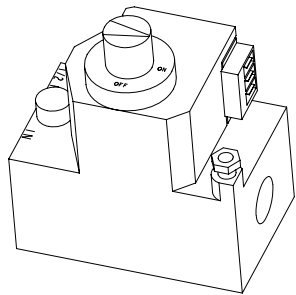

1 Non-CE Gas Valve(s)

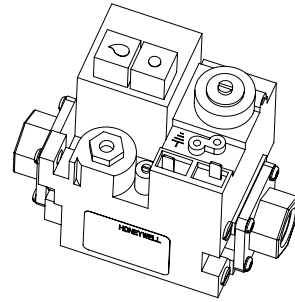

2 CE Gas Valve(s)

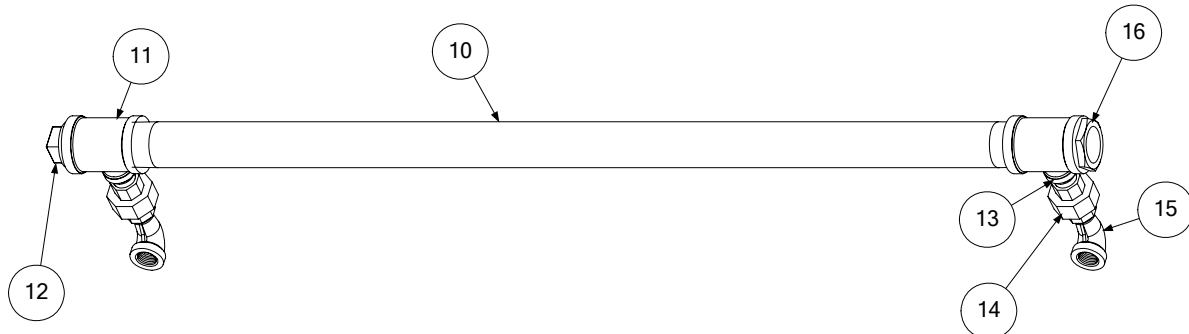
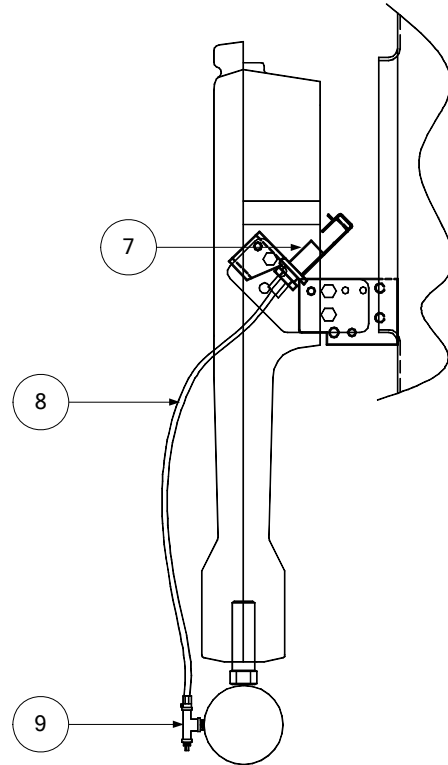
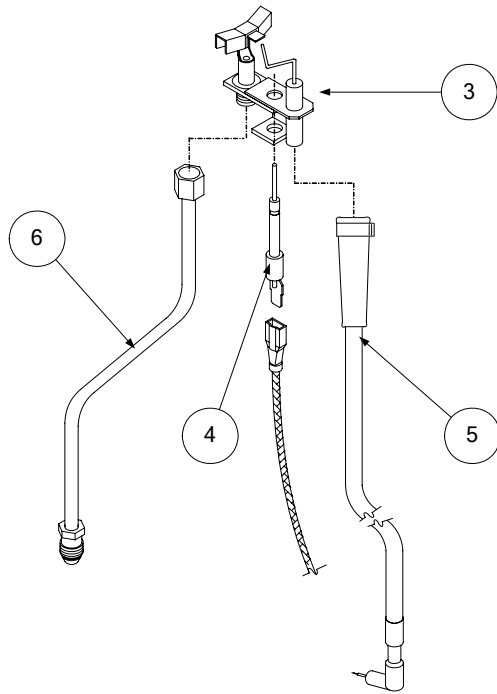

**KSCF18G COOL ZONE SERIES GAS FRYERS**  
**CHAPTER 8: PARTS LIST: DOUBLE & TRIPLE UNITS (218G/318G)**

**8.8 Gas Valves, Pilot Assemblies, and Related Components (cont.)**

ITEM	PART #	COMPONENT
1	807-3552	Gas Valve, Natural and Manufactured Gas, 24V (Non-CE)
*	807-3628	Gas Valve, LP, 24V (Non-CE)
2	806-6710SP	Gas Valve, Natural Gas, 24V (CE)
*	806-6711SP	Gas Valve, LP, 24V (CE)
*	810-0691	Vent Tube
*	813-0066	Elbow, 3/4" 90° NPT BM
*	813-0664	Nipple, 3/4 x 1 1/2" NPT BM
*	813-0174	Union, 3/4" NPT BM
*	106-1768SP	ECO Connector Assembly (CE)
3	810-2032	Pilot Burner, Natural, Electronic Ignition
*	807-1553	Pilot Burner, LP, Electronic Ignition
*	812-1284	Thermocouple (CE)
*	807-3550	Thermocouple (Non-CE)
*	807-3485	Thermopile (Non-CE)
4	807-1310	Flame Sensor, Ignitor
5	106-3553	Cable, Ignitor
*	826-2117	Module, Ignition/Spark
*	106-2351SP	Harness, Spark Module
*	106-0978SP	Harness, Spark Module/Valve
6	810-0705	Gas Line, Pilot Supply - 1/4 x 20"
*	810-1172	Gas Line, Pilot Supply - 1/4 x 23" (CE Only)
<b>Trailing Pilot Assembly</b>		
7	810-2155	Pilot Burner, RS (LP)
*	810-2032	Pilot Burner, RS (Natural)
8	810-0703	Gas Line, 1-Piece - 1/4 x 17 1/2"
9	810-2138	Valve, Pilot Adjustment - 1/8" NPT x 1/4" CC
*	809-0845	Screw, 10-32 x 3/8"
*	809-0766	Nut, 10-32 SS Hex Head
<b>Rear Gas Manifold Components</b>		
10	813-0882	Pipe (Nipple), 1 1/4" x 34 3/4" TBE NPT
11	813-0637	Tee, 1 1/4" x 1 1/4" x 1/2" NPT BM
12	813-0658	Plug, 1 1/4" Square Head NPT BM
13	813-0022	Nipple, 1/2" x Close NPT BM
14	813-0173	Union, 1/2" NPT BM
15	813-0165	Elbow, Street - 1/2"- 90° NPT BM
16	813-0716	Bushing, 1" x 1 1/4" Hex BM
*	810-2043	Clamp, 1/2"
<b>Piezo Ignitor Components</b>		
	210-6564	Bracket, Pilot Thermocouple (CE)
	810-1001	Trigger, Piezo Ignitor (CE)
	200-1868	Piezo Bracket (CE)
	807-3540	Electrode, Piezo (CE)

\* Not illustrated.

KSCF18G COOL ZONE SERIES GAS FRYERS  
CHAPTER 8: PARTS LIST: DOUBLE & TRIPLE UNITS (218G/318G)

8.9 Over-the-Top Oil Return and Related Components

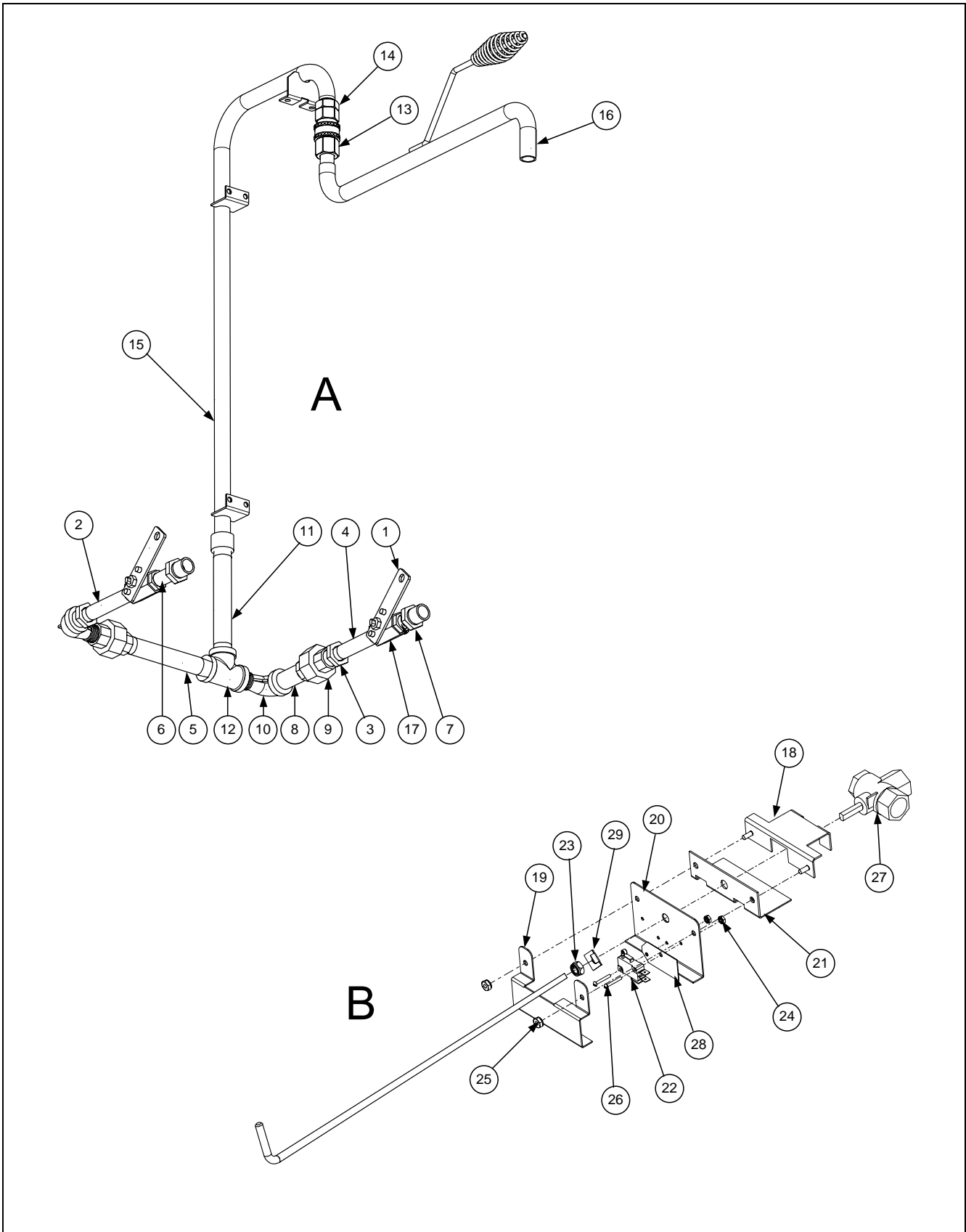

**KSCF18G COOL ZONE SERIES GAS FRYERS**  
**CHAPTER 8: PARTS LIST: DOUBLE & TRIPLE UNITS (218G/318G)**

**8.9 Over-the-Top Oil Return and Related Components (cont.)**

ITEM	PART #	COMPONENT
<b>A</b>	<b>106-2983</b>	<b>Oil Return Assembly</b>
1	823-3344	Handle, Oil Return
2	813-0826	Nipple, 3/8" x 4, BM
3	813-0780	Bushing, Hex 3/8" NPT x 1/2", BM
4	813-0777	Nipple, 3/8" x 3 1/2", BM
5	813-0742	Nipple, 1/2" x 5.50 NPT, BM
6	813-0676	Nipple, Black, TBE 3/8" NPT x 2"
7	813-0625	Nipple, 3/8" x Close NPT, BM
8	813-0265	Nipple, 1/2" x 2.5 NPT, BM
9	813-0173	Union, 1/2" NPT, BM
10	813-0165	Elbow, Street, 1/2" x 1/2" NPT, 90°, BM
11	813-0096	Nipple, 1/2" x 6.0" NPT, BM
*	813-0093	Nipple, 1/2" x 4.0" NPT, BM <i>(replaces Item 11 in some models)</i>
12	813-0003	Tee, 1/2" x 1/2" x 1/2", BM
13	810-2700	Nipple, Quick Disconnect, Snaptite
14	810-2699	Coupling, Quick Disconnect, Snaptite
15	813-2514	Tubing, Faucet, Lower
16	813-2513	Tubing, Faucet, Upper
17	810-2125	Drain Valve, 3/8"
<b>B</b>	<b>106-4763</b>	<b>3-Way Oil Return Valve Assembly</b>
18	106-5229	Support, Oil Return Valve
19	210-9915	Cover, Microswitch
20	210-9917	Support, Microswitch Mount
21	210-9918	Brace, 3-Way Bottom
22	807-2104	Switch, CE Micro-roller Lever
23	809-0056	Nut, 5/16"-18 Hex
24	809-0237	Nut, 4-40 Keps Hex with Extension Teeth
25	809-0256	Nut, 10-32 Keps Hex
26	809-0354	Screw, 4-40 x 3/4" Round Head
27	810-1003	180° 3-Way Ball Valve
28	816-0220	Insulation, Switch
29	900-2935	Retainer Nut

\* Not illustrated.

# KSCF18G COOL ZONE SERIES GAS FRYERS

## CHAPTER 9: PARTS LIST: SINGLE UNITS (118G)

For parts and/or components not listed, contact the Frymaster Service Hotline at 1-800-551-8633 or 1-318-865-1711 for additional service and parts information.

### 9.1 Cabinetry and Related Components

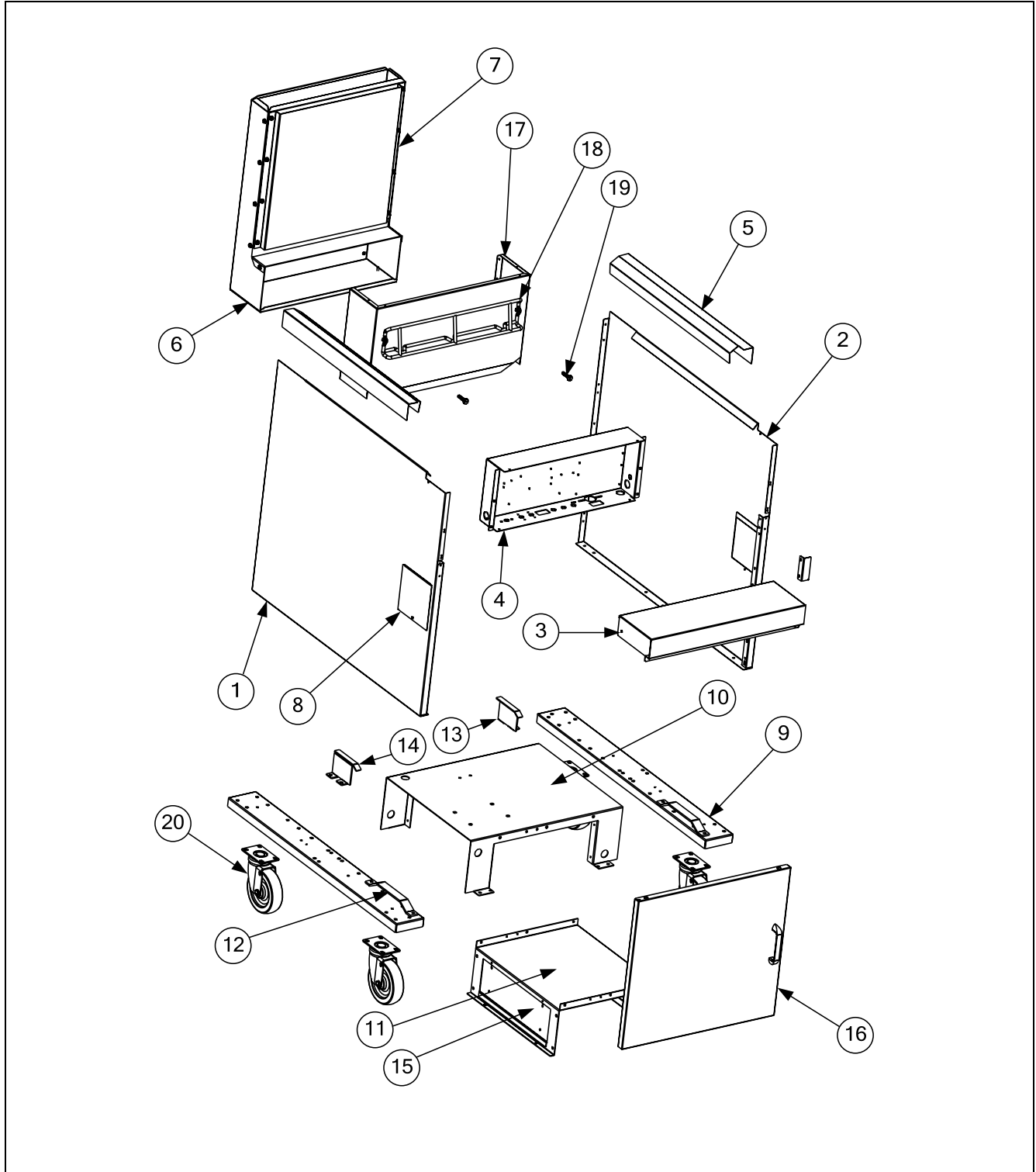

**KSCF18G COOL ZONE SERIES GAS FRYERS  
CHAPTER 9: PARTS LIST: SINGLE UNITS (118G)**

**9.1 Cabinetry and Related Components (cont.)**

ITEM	PART #	COMPONENT
1	201-1299	Side, Painted Panel, Left
2	202-1299	Side, Painted Panel, Right
*	211-4570	Side, Stainless Steel, Left
*	212-4570	Side, Stainless Steel, Right
*	200-5036	Back, Structural, Over-the-top Oil Return
3	824-0987	Top Cap, Single
*	823-4567	Marine Edge, Single
4	824-1195	Panel, Wireway ( <i>KCF118GN and KCF118GP</i> )
*	824-0941	Panel, Wireway ( <i>KCF118N and KCF118P</i> )
5	211-8178	Joiner Strip, Left
6	212-8178	Joiner Strip, Right
7	106-0997SP	Flue Assembly
	200-1773	Back, Flue
	200-1339	Front, Flue
	200-1325	Heat Shield, Flue
*	200-3649	Flue Deflector
8	210-2804	Duct, Door Access
*	210-9416	Duct, Rear Access
9	823-4321	Channel, Leg Support
10	200-3491	Base, Upper
11	200-3494	Base, Lower
12	210-3636	Slide, Front and rear
13	823-3751	Bracket, Slide Rear, Left
14	823-3752	Bracket, Slide Rear, Right
15	200-3517	Cover, Base, Electrical
16	106-4721	Door Assembly (hinges on left when facing fryer)
*	823-5346	Hinge, Lower Left
*	823-5348	Hinge, Upper Left
*	106-4722	Door Assembly (hinges on right when facing fryer)
*	823-5347	Hinge, Lower Right
*	823-5349	Hinge, Upper Right
*	106-2816	Door Assembly, 118G with Matching Cabinet
*	810-1105	Magnet, Door
17	823-4282	Flue Cap
18	810-2794	Basket Hanger
19	809-0171	Thumbscrew, Basket Hanger
20	810-0356	Caster, 5" ( <i>without brake</i> )
*	810-0357	Caster, 5" ( <i>with brake</i> )
*	806-5043	Leg, 6"
*	200-1183	Crisper Tray without Handles

\* Not illustrated.

**KSCF18G COOL ZONE SERIES GAS FRYERS  
CHAPTER 9: PARTS LIST: SINGLE UNITS (118G)**

**9.2 Accessories**

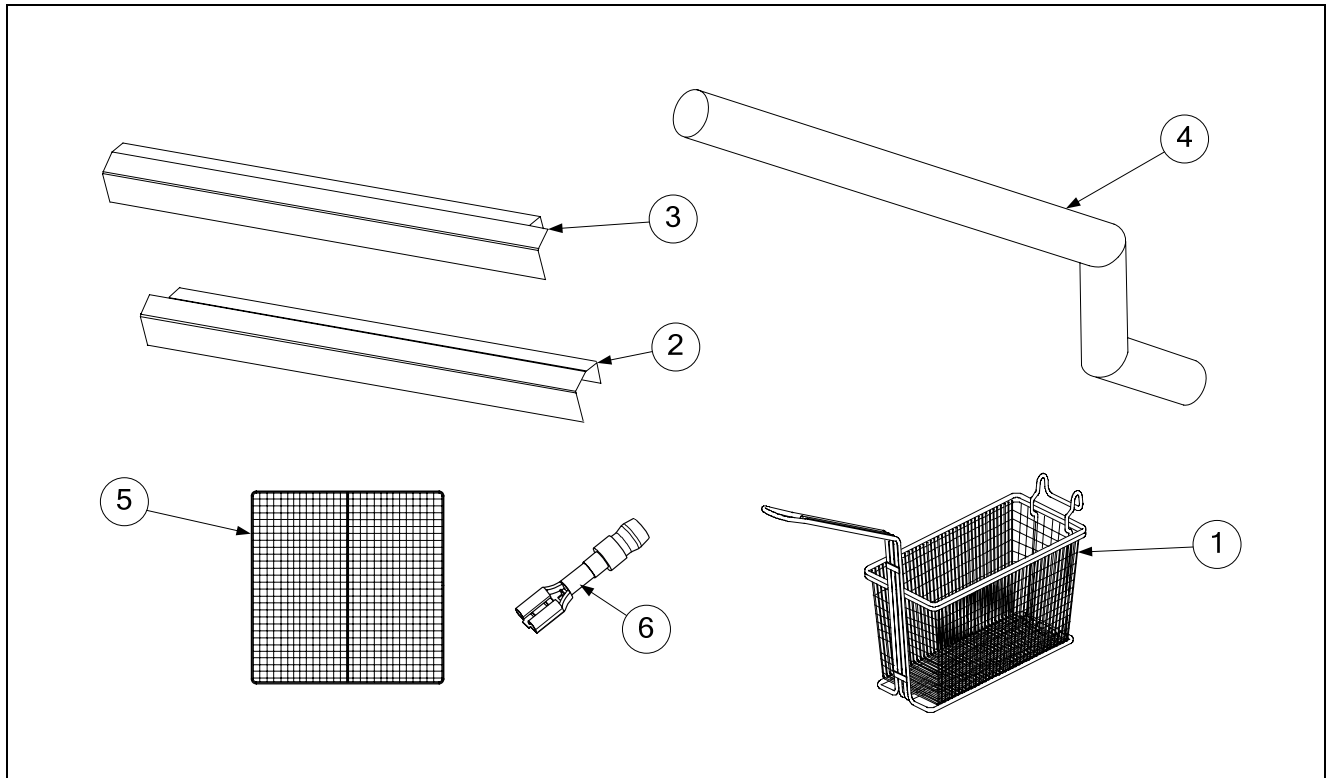

ITEM	PART #	COMPONENT
1	803-0306	Twin Fry Basket
2	211-8178	Joiner Strip (to mount unit to the left of a 2424G)
3	212-8178	Joiner Strip (to mount unit to the right of a 2424G)
4	823-5404	Drain Tube (to attach unit drain to a 2424G)
5	803-0149	Basket Support Screen
*	810-2235	Basket Support Grid
6	807-3484	Rajah Connector (included in module kit, P/N 826-2117)
*	803-0293	Gloves, Neoprene (pair)
*	803-0197	Fryer's Friend
*	803-0278	Brush, L-shaped
*	803-0209	Brush, Frypot
*	807-0154	Cord Set, Fryer/Motor

\* Not illustrated.

**KSCF18G COOL ZONE SERIES GAS FRYERS  
CHAPTER 9: PARTS LIST: SINGLE UNITS (118G)**

**9.3 Component Box, Computers, and Related Components**

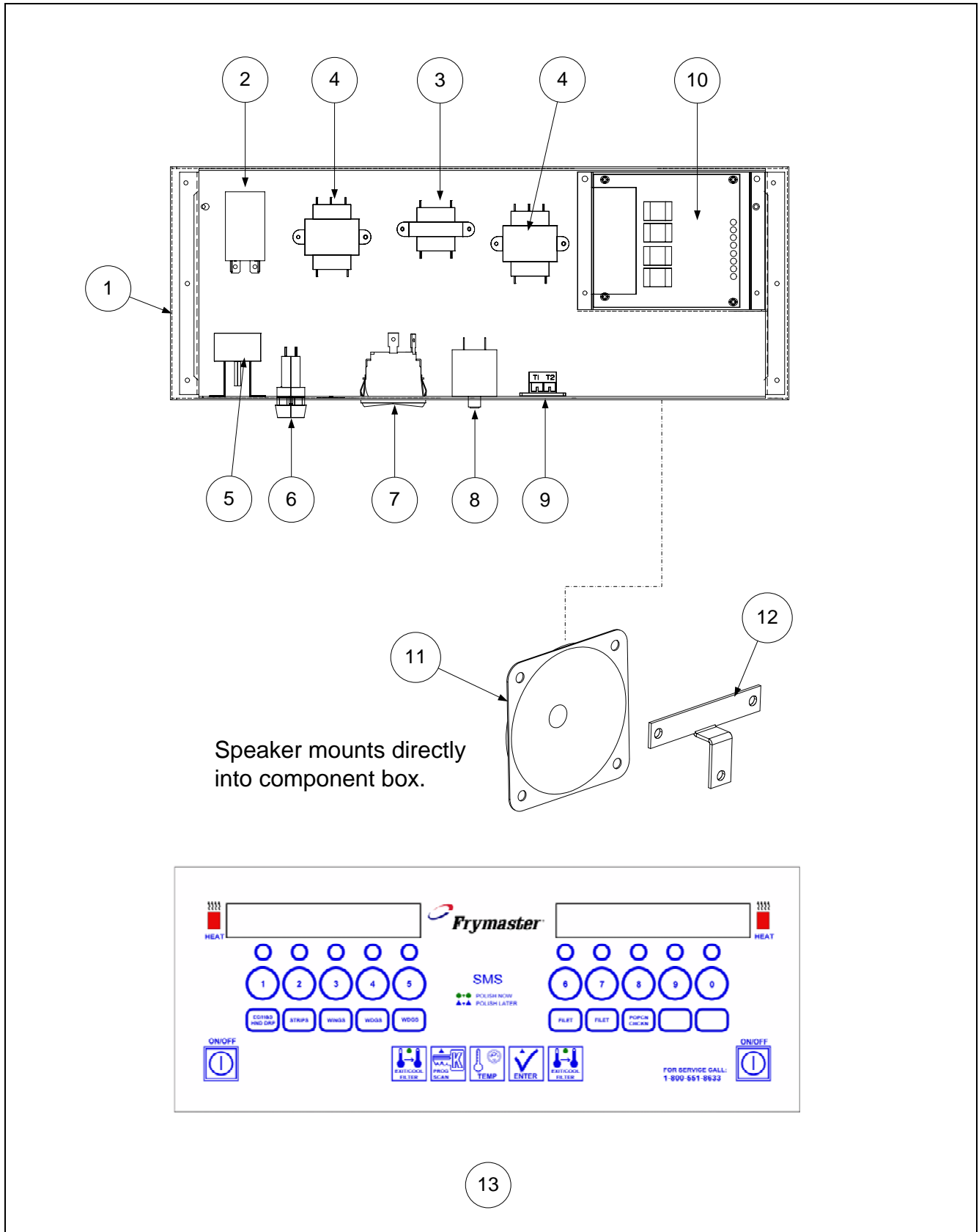

**KSCF18G COOL ZONE SERIES GAS FRYERS  
CHAPTER 9: PARTS LIST: SINGLE UNITS (118G)**

**9.3 Component Box, Computers, and Related Components (cont.)**

ITEM	PART #	COMPONENT
1	824-1195	Component Box ( <i>KCF118GN and KCF118GP</i> )
*	824-0941	Component Box ( <i>KCF118N and KCF118P</i> )
2	807-4114	Relay, DPDT, 24VAC
*	106-1414	Relay Socket ( <i>includes item 2</i> )
*	807-0012	Relay, 18 Amp, 1/3 HP, 24V Coil (Export)
*	807-0834	Relay, Basket Lift, 15 Amp, 12V
3	807-0855	Transformer, 120V to 12V
4	807-0800	Transformer, 120V to 24V (Fryer and Filter Circuit)
*	807-0680	Transformer, 240V to 24V
*	807-1999	Transformer, Dual Voltage (CE only)
5	▶▶	<b>See Page 9-10 for High-Limit Thermostats</b>
6	807-0922	Holder, Buss Fuse
*	807-3592	Fuse, 2 Amp Slow Blow
7	807-3580	Switch, Filter By-pass Rocker
8	807-3577	Circuit Breaker, Filter, 7 Amp (120V units)
9	810-1164	Block, Terminal
10	106-6669	Interface Board, Standing Pilot, SMT
*	826-2256	Interface Board, Electronic Ignition, SMT
*	106-6670	Interface Board, Fast Ready, Standing Pilot, SMT
*	106-6671	Interface Board, Fast Ready, No Basket Lift, SMT
11	807-3520	Speaker, Sound Device
*	807-4330	SMT Adapter, Sound Device
12	200-2052	Bracket, Speaker
*	200-1596	Cover, Sound Device Mount
*	200-1597	Shield, Sound Device Cover
*	807-3546	Bushing, Heyco, 3/4"
*	809-0360	Screw, #8 x 3/8" Type B Hex Washer
*	809-0766	Nut, 10-32 Hex Head
13	806-9727	Computer, KFC-1
*	823-2882	Control Panel, Computer
*	809-0824	Screw, Control Panel
*	826-2117	Spark Module Kit (includes rajah adapter, P/N 807-3484)
*	819-5733	KFC-1 SMS Operating Instructions

\* Not illustrated.

**KSCF18G COOL ZONE SERIES GAS FRYERS  
CHAPTER 9: PARTS LIST: SINGLE UNITS (118G)**

**9.4 Drain Valve, Oil Return, and Related Components**

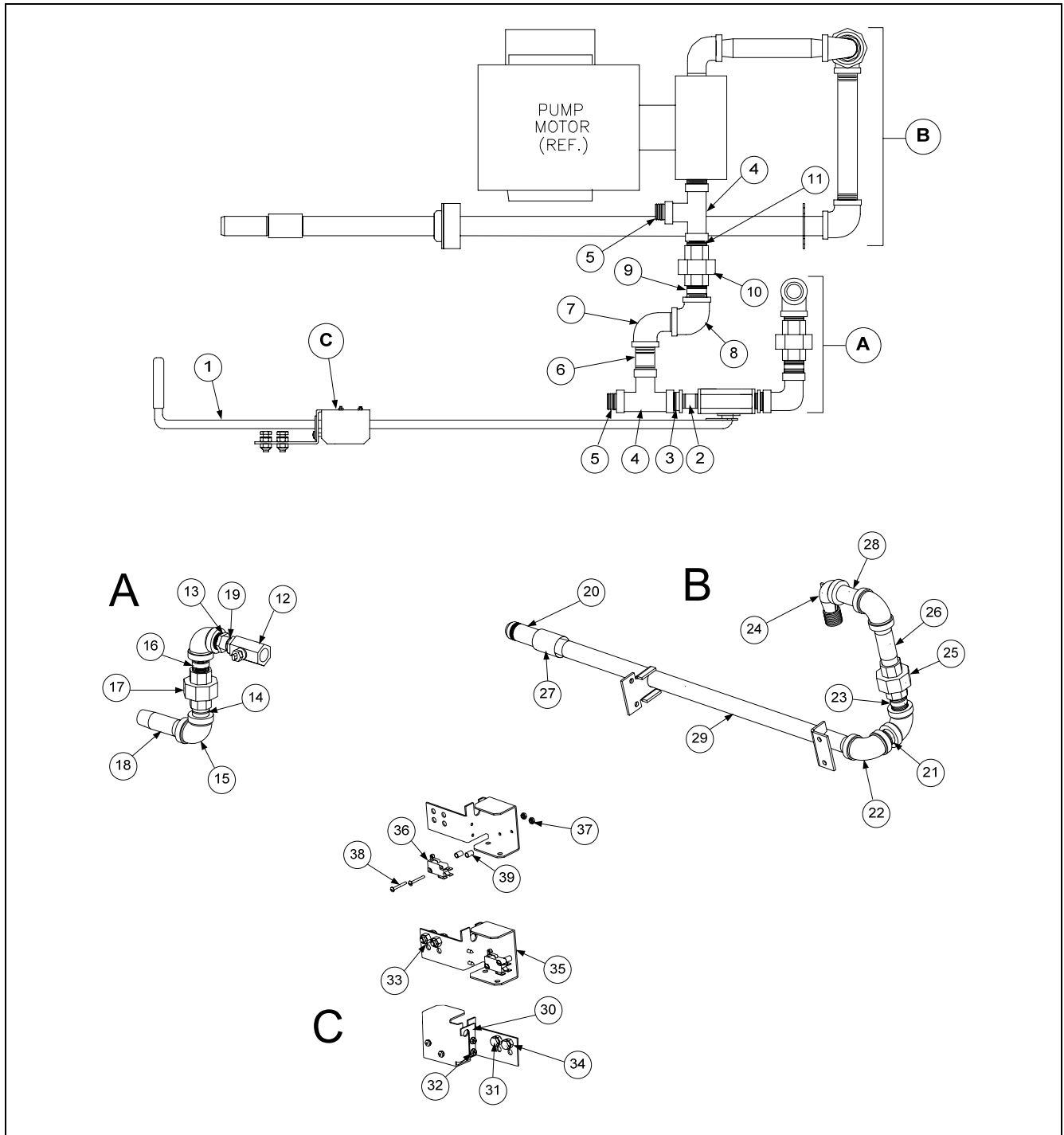

ITEM	PART #	COMPONENT
1	106-0754SP	Oil Return Handle Assembly
2	813-0644	Nipple, 3/8" NPT x 1 1/2", Black Tube
3	813-0006	Bushing, 1/2" to 3/8" NPT, Hex, BM
4	813-0003	Tee, 1/2" NPT, BM
5	813-0463	Plug, 1/2" Counter Sink

**KSCF18G COOL ZONE SERIES GAS FRYERS  
CHAPTER 9: PARTS LIST: SINGLE UNITS (118G)**

**9.4 Drain Valve, Oil Return, and Related Components (cont.)**

ITEM	PART #	COMPONENT
6	813-0298	Nipple, ½" NPT x 2", BM
7	813-0165	Elbow, Street, ½" NPT, 90°
8	813-0062	Elbow, ½" NPT, 90°, BM
9	813-0087	Nipple, ½" NPT x 1 ½", BM
10	813-0173	Union, ½" NPT, 150#, BM
11	813-0022	Nipple, ½" NPT x Close, BM
*	106-2387	Heater Tape Assembly, 36", 120V, 25W
19	826-1712	Motor, Filter Pump, 115V, 60 Hz, Baldor (810-2100 prior to 11/2006)
20	810-3071	Pump, 8GPM, Filter (810-2098 prior to 11/2006)
*	810-2252	Pump, 5GPM, Filter
*	816-0093	Gasket, Pump/Motor
<b>A</b>	<b>106-2214</b>	<b>Oil Return Assembly</b>
12	810-2125	Drain Valve, ⅜"
13	813-0006	Bushing, ½" to ⅜" NPT, Hex, BM
14	813-0022	Nipple, ½" x Close, NPT, BM
15	813-0062	Elbow, ½", 90°, BM
16	813-0087	Nipple, ½" x 1.5" NPT, BM
17	813-0173	Union, ½" NPT, BM
18	813-0460	Nipple, ½" x 3" NPT, BM
19	813-0625	Nipple, ⅜" x Close NPT, BM
<b>B</b>	<b>106-2215</b>	<b>Oil Suction Components</b>
20	810-0697	Disconnect, Male
21	813-0022	Nipple, ½" x Close NPT, BM
22	813-0062	Elbow, ½", 90°, BM
23	813-0087	Nipple, ½" x 1.5" NPT, BM
24	813-0165	Elbow, Street, ½" x ½", 90, BM
25	813-0173	Union, ½" x 3" NPT, BM
26	813-0460	Nipple, ½" x 3" NPT, BM
27	813-0608	Coupling, ½" NPT, Full, BM
28	813-0661	Nipple, ½" x 2.25" NPT, BM
29	823-3754	Manifold, Suction
<b>C</b>	<b>106-0979</b>	<b>Oil Return Bracket Assembly</b>
30	200-1341	Bracket, Microswitch Rod
31	809-0131	Screw, ¼-20 x ¾", Hex Head
32	809-0361	Screw, #8 x ½" Hex Head, Drill
33	809-0823	Nut, ¼-20, Nylock
34	809-0825	Nut, Keps, ¼-20, Hex Head, Stainless Steel
	106-0893SP	Bracket Assembly
35	202-4455	Bracket, Right Microswitch Flushline
36	807-2104	Switch, CE Microroller Lever
37	826-1366	Nut, 4-40 Keps Hex w/Extension Teeth (pkg. of 25)
38	809-0846	Screw, 4-40 x 1", Pin, Slotted Head
39	810-2144	Spacer, Aluminum, 1/4" O.D. x ⅜" Long, 4-40

\* Not illustrated.

**KSCF18G COOL ZONE SERIES GAS FRYERS**  
**CHAPTER 9: PARTS LIST: SINGLE UNITS (118G)**

**9.5 Filter Pan and Related Components**

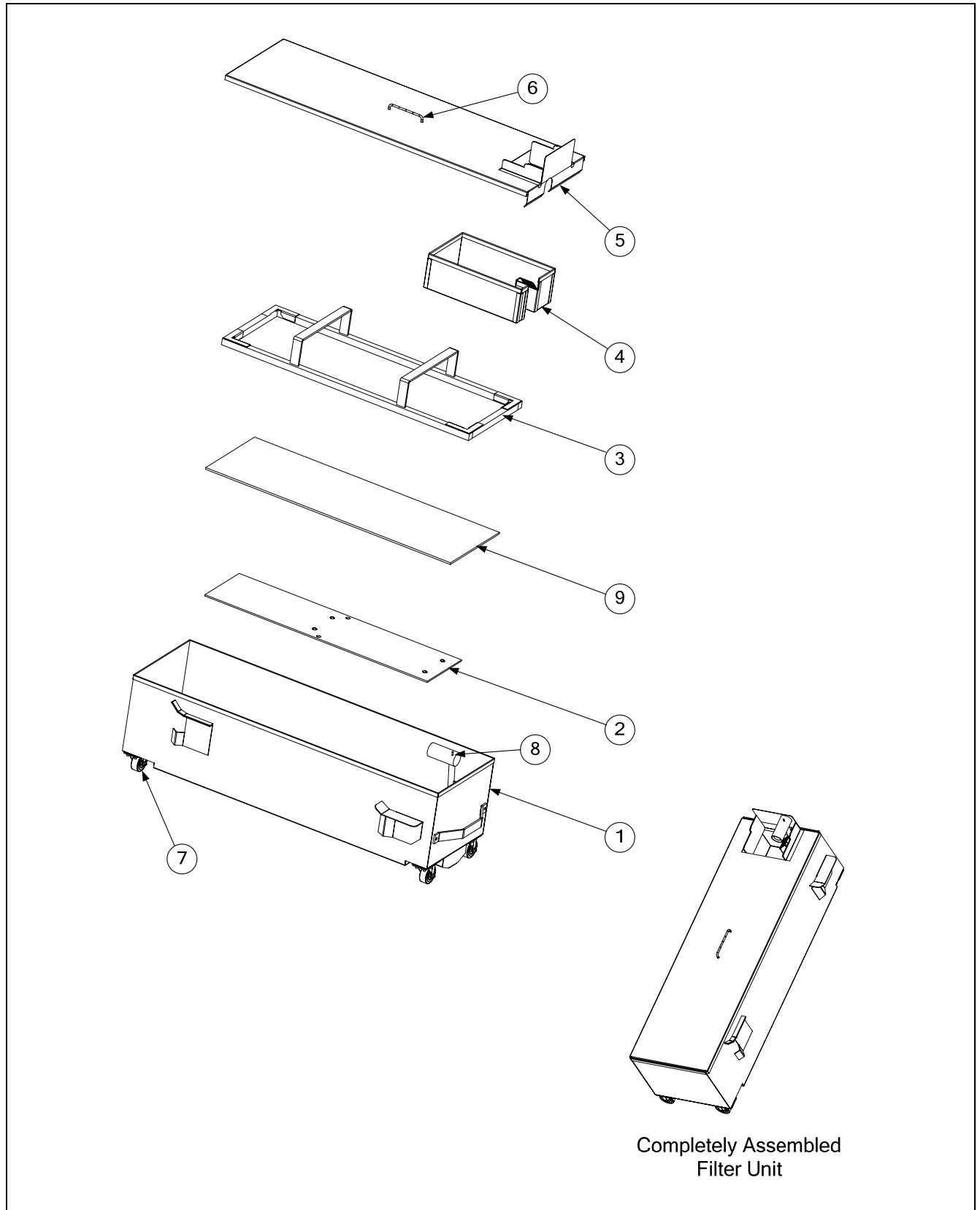

**KSCF18G COOL ZONE SERIES GAS FRYERS  
CHAPTER 9: PARTS LIST: SINGLE UNITS (118G)**

**9.5 Filter and Related Components (cont.)**

ITEM	PART #	COMPONENT
<b>Filter Components</b>		
1	823-4439	Pan, Filter
2	106-7331SP	Grid, Wire
3	823-5422	Hold Down Ring
4	823-3736	Crumb Basket
5	823-4440	Lid, Filter Pan
6	230-0124	Handle, Filter Pan Lid
7	810-2805	Caster, 2" Filter Pan
*	809-0070	Nut, ¼-20 Hex
*	826-1388	Washer, ¾" O.D. x ¼" I.D. ( <i>pkg. of 5</i> )
8	813-0679	Plug, ⅛", Stainless Steel, Square Head
*	813-0684	Plug, ⅜", Stainless Steel, Hex Socket ( <i>in bottom of pan</i> )
<b>Filter Components (non-CE Export)</b>		
*	106-5325SP	Pan, Filter
*	823-5421	Grid, Latch-less
*	823-5422	Hold Down Ring
*	823-5423	Crumb Basket
*	823-5424	Lid, Front
*	823-5425	Lid, Rear
*	230-0124	Handle, Filter Pan Lid
<b>Other Components</b>		
*	803-0278	Teflon Brush
*	803-0002	Filter Powder
9	803-0345	Filter Paper, 17" X 33.25" ( <i>pkg. of 25 sheets</i> )

\* Not illustrated.

**KSCF18G COOL ZONE SERIES GAS FRYERS**  
**CHAPTER 9: PARTS LIST: SINGLE UNITS (118G)**

**9.6 Frypot and Related Components**

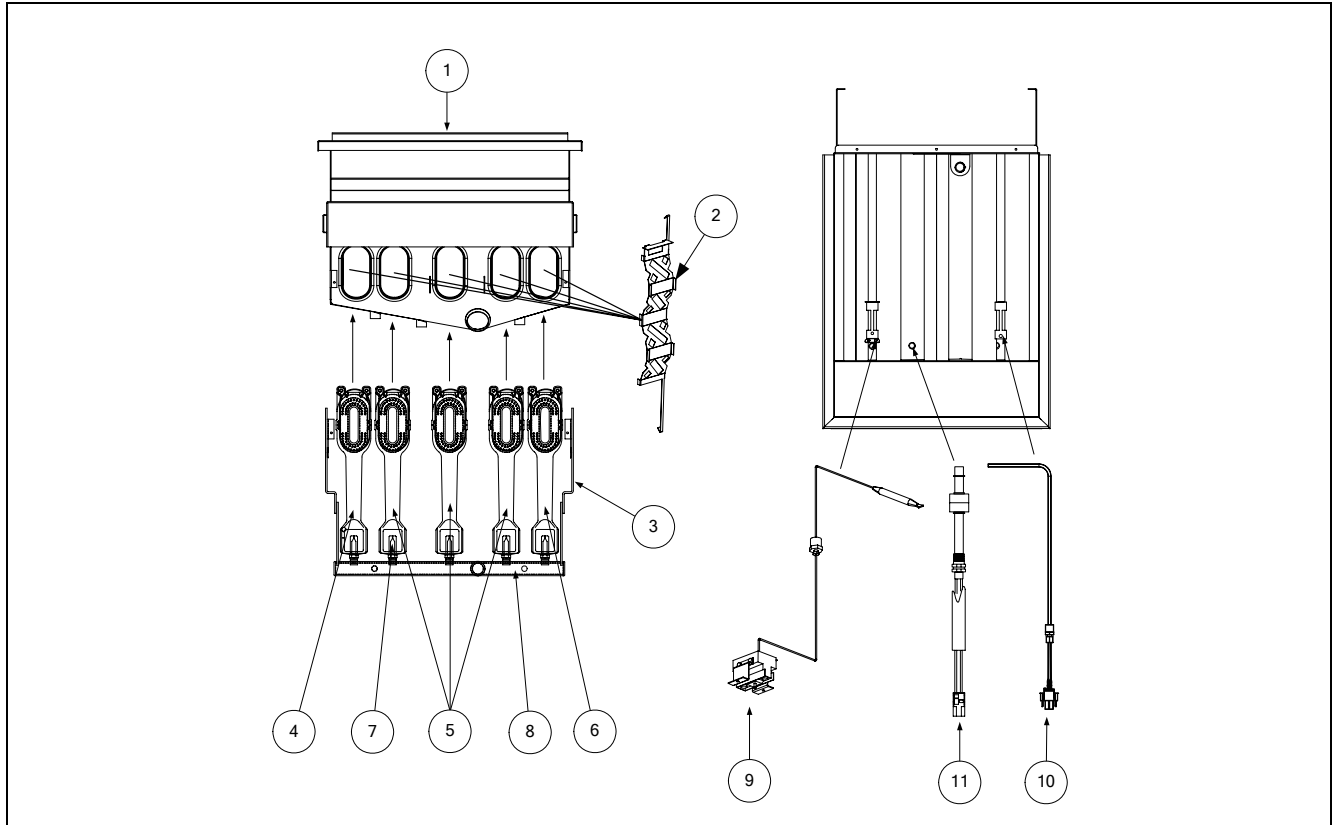

ITEM	PART #	COMPONENT
1	823-4884SP	Frypot, Stainless Steel, with 1½" Drain
*	803-0149	Grid, Frypot
2	210-8387	Diffuser Assembly
3	200-1615	Support, Manifold
4	810-2151	Burner, Left
5	810-2149	Burner, Center
6	810-2150	Burner, Right
*	200-3081	Shutter, Air (CE only)
7	810-2062	Orifice, 2.58 mm (#38)
*	810-2048	Orifice, 2.53 mm (#39) (Non-CE)
*	810-2060	Orifice, 2.40 mm (#42) (CE-blue)
*	810-2059	Orifice, 1.51 mm (#53) (Non-CE & CE-red)
*	810-2497	Orifice, 1.32 mm (#55) (LP)
*	810-2365	Orifice, 1.19 mm (#56) (LP)
*	810-2600	Orifice, 4.22 mm (#19) (MFG)
8	810-2072	Manifold, Gas
9	807-3680	High-Limit with Manual Reset - 450°F (232°C)
*	807-3560	High-Limit with Manual Reset - 410°F (210°C)
*	210-1433	High-Limit Bracket
10	106-1424	Temperature Probe
11	826-2146	Float Switch Kit

\* Not illustrated.

**KSCF18G COOL ZONE SERIES GAS FRYERS  
CHAPTER 9: PARTS LIST: SINGLE UNITS (118G)**

**9.7 Gas Valves, Pilot Assemblies, and Related Components**

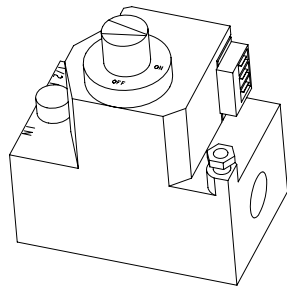

1 Non-CE Gas Valve(s)

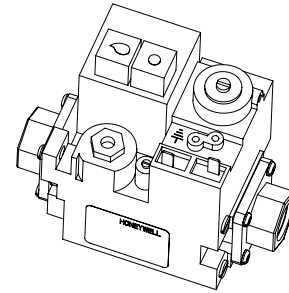

2 CE Gas Valve(s)

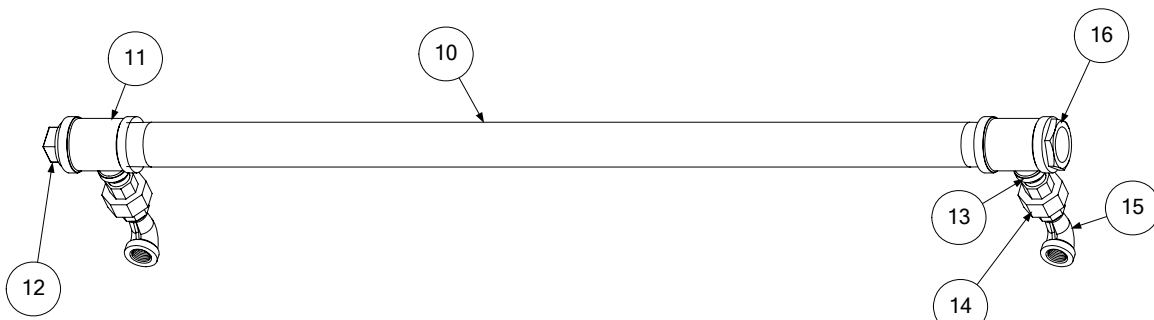
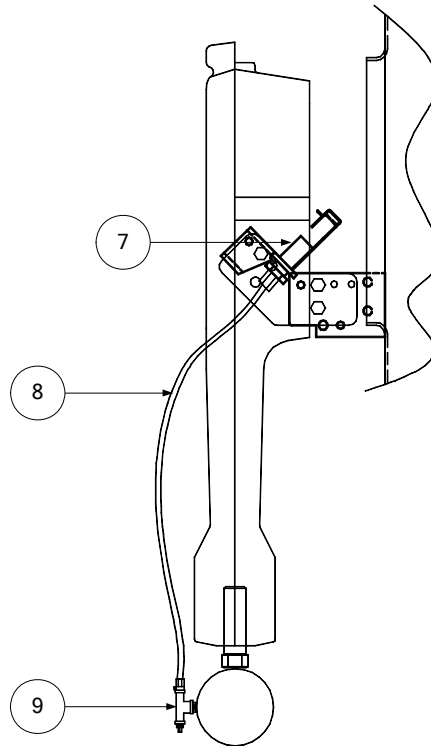
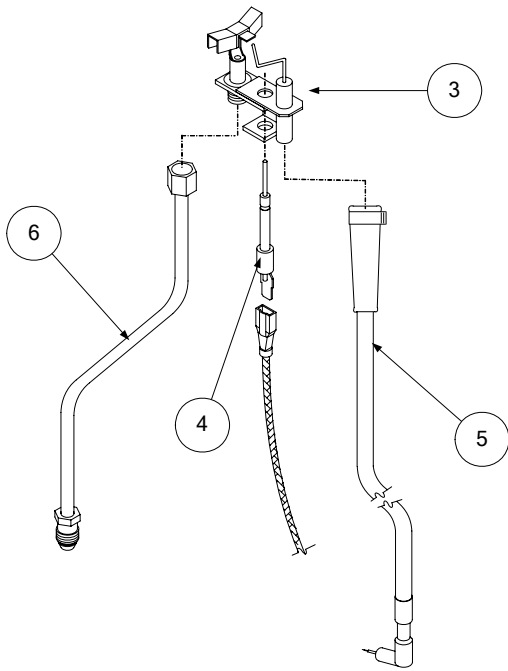

**KSCF18G COOL ZONE SERIES GAS FRYERS  
CHAPTER 9: PARTS LIST: SINGLE UNITS (118G)**

**9.7 Gas Valves, Pilot Assemblies, and Related Components (cont.)**

ITEM	PART #	COMPONENT
1	807-3552	Gas Valve, Natural Gas, 24V (Non-CE)
*	807-3628	Gas Valve, LP, 24V (Non-CE)
2	806-6710SP	Gas Valve, Natural Gas, 24V (CE)
*	806-6711SP	Gas Valve, LP, 24V (CE )
*	810-0691	Vent Tube
*	200-1450	Bracket, Gas Valve Support
*	813-0066	Elbow, ¾" 90° NPT, BM
*	813-0664	Nipple, ¾"x 1½" NPT, BM
*	813-0607	Nipple, ½" NPT X 23-½, BM
*	813-0174	Union, ¾" NPT, BM
*	106-1768SP	ECO Connector Assembly (CE)
3	810-2032	Pilot Burner, Natural, Electronic Ignition
*	807-1553	Pilot Burner, LP, Electronic Ignition
4	807-1310	Flame Sensor, Ignitor
5	807-3983	Cable, Ignitor
*	826-2117	Module, Ignition/Spark
*	106-2351SP	Harness, Spark Module
*	106-0978SP	Harness, Spark Module/Valve
6	810-0705	Gas Line, Pilot Supply - ¼ x 20"
*	810-1172	Gas Line, Pilot Supply - ¼ x 23" (CE Only)
<b>Trailing Pilot Assembly</b>		
7	810-2155	Pilot Burner, RS (LP)
*	810-2032	Pilot Burner, RS (Natural)
8	810-0703	Gas Line, 1-Piece - ¼" x 17 ½"
9	810-2138	Valve, Pilot Adjustment - ⅛" NPT x ¼ CC
*	809-0845	Screw, 10-32 x 3/8"
*	809-0766	Nut, 10-32 SS Hex Head
<b>Rear Gas Manifold Components</b>		
10	813-0882	Pipe (Nipple), 1.25" x 34.75" TBE NPT
11	813-0637	Tee, 1¼" x 1¼" x ½" NPT, BM
12	813-0658	Plug, 1¼" Square Head NPT, BM
13	813-0022	Nipple, ½" x Close NPT, BM
14	813-0173	Union, ½" NPT, BM
15	813-0165	Elbow, Street - ½"- 90° NPT, BM
16	813-0716	Bushing, 1" x 1¼ Hex, BM
*	810-2043	Clamp, ½"

\* Not illustrated.

KSCF18G COOL ZONE SERIES GAS FRYERS  
CHAPTER 9: PARTS LIST: SINGLE UNITS (118G)

9.8 Over-the-Top Oil Return and Related Components

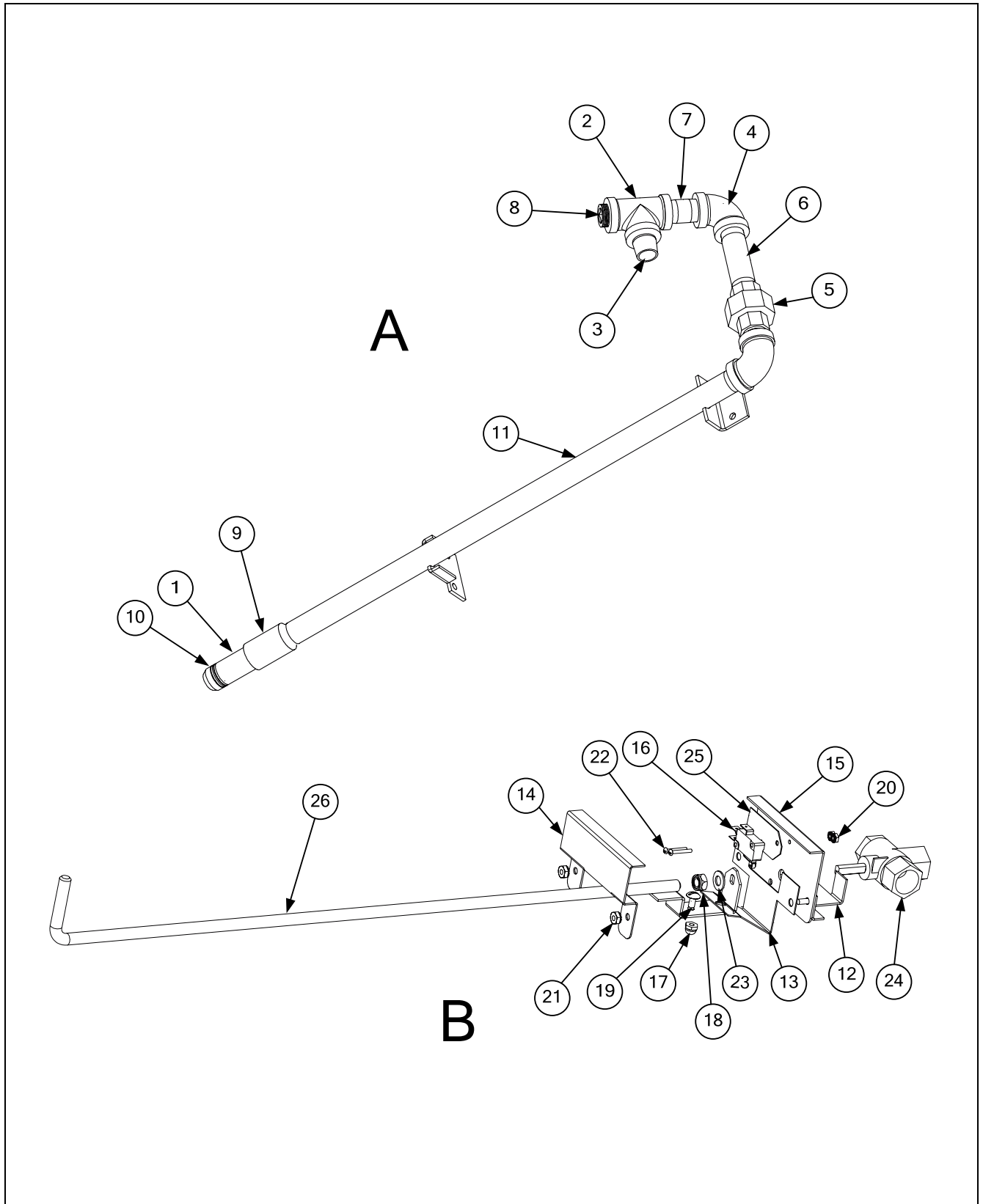

**KSCF18G COOL ZONE SERIES GAS FRYERS  
CHAPTER 9: PARTS LIST: SINGLE UNITS (118G)**

**9.8 Over-the-Top Oil Return and Related Components (cont.)**

ITEM	PART #	COMPONENT
<b>A</b>	<b>106-3347</b>	<b>Oil Return Assembly</b>
1	810-0697	Disconnect, Male
2	813-0003	Tee, 1/2" x 1/2" x 1/2", BM
3	813-0022	Nipple, 1/2" x Close NPT, BM
4	813-0062	Elbow, 1/2", BM, 90°
5	813-0173	Union, 1/2" NPT, BM
6	813-0247	Nipple, 1/2" x 3.50 NPT, BM
7	813-0298	Nipple, 1/2" x 2.00 NPT, BM
8	813-0463	Plug, 1/2" Counter Sink
9	813-0608	Coupling, 1/2" NPT, Full, BM
10	816-0596	O-ring, .070 x .750
11	823-3754	Manifold, Suction
<b>B</b>	<b>106-5230</b>	<b>3-Way Oil Return Valve Assembly</b>
12	106-5229	Support, Oil Return Valve
13	210-9643	Spring Clip
14	210-9915	Cover, Microswitch
15	210-9916	Support, Microswitch Mount
16	807-2104	Switch, CE Microroller Lever
17	809-0045	Nut, Cap, 10-32 Hex
18	809-0056	Nut, 5/16-18 Hex
19	809-0117	Screw, 10-32 x 3/8", Slotted Truss Head
20	809-0237	Nut, 4-40 Keps Hex with Extension Teeth
21	809-0256	Nut, 10-32 Keps Hex
22	809-0354	Screw, 4-40 x 3/4" Round Head
23	809-0942	Washer, 5/16" Belleville, 18-8, Stainless Steel
24	810-1003	180° 3-Way Ball Valve
25	816-0220	Insulation, Switch
26	823-5362	Handle, 3-Way Valve, Over-the-Top
*	810-2700	Nipple, Quick Disconnect, Snaptite
*	813-0780	Bushing, Hex 1/2" x 3/8" NPT, BM
*	810-2127	Drain Valve, 1 1/2", Full Port

\* Not illustrated.

# *Frymaster*<sup>®</sup>

FRYMASTER  
8700 LINE AVENUE, SHREVEPORT, LA 71106-6800

800-551-8633  
318-865-1711  
[WWW.FRYMASTER.COM](http://WWW.FRYMASTER.COM)  
EMAIL: [FRYSERVICE@WELBILT.COM](mailto:FRYSERVICE@WELBILT.COM)



Welbilt offers fully-integrated kitchen systems. Welbilt's portfolio of award-winning brands includes Cleveland™, Convotherm®, Crystal Tips®, Dean®, Delfield®, Fabristeel®, Frymaster®, Garland®, Inducs®, Koldtech®, Kolpak®, Lincoln®, McCann's™, Merco®, Merrychef®, Multiplex®, RDI®, SerVend™, SunFire®, U.S. Range™, and WMaxx™. Supported by service brands: FitKitchen®, kitchen systems; and KitchenConnect®, cloud-based open platform.

*Bringing innovation to the table* • [welbilt.com](http://welbilt.com)

©2023 Frymaster LLC. except where explicitly stated otherwise. All rights reserved. Continuing product improvement may necessitate change of specifications without notice.

Part Number FRY\_IOSP\_8195712 10/2023