

Gas Cooker Models

GSMs, GBC and GC

(Including GSW and GWB Variants)

Service and Parts Manual

 **Frymaster**® 



Frymaster, a member of the Commercial Food Equipment Service Association, recommends using CFESA Certified Technicians.

24-Hour Service Hotline 1-800-551-8633

JAN 2013



⚠ DANGER

IMPROPER INSTALLATION, ADJUSTMENT, ALTERATION, SERVICE, OR MAINTENANCE CAN CAUSE PROPERTY DAMAGE, INJURY, OR DEATH. READ THE INSTALLATION, OPERATING, AND SERVICE INSTRUCTIONS THOROUGHLY BEFORE INSTALLING OR SERVICING THIS EQUIPMENT.

⚠ DANGER

FOR YOUR SAFETY, DO NOT STORE OR USE GASOLINE OR OTHER FLAMMABLE LIQUIDS OR VAPORS IN THE VICINITY OF THIS OR ANY OTHER APPLIANCE.

⚠ DANGER

POST IN A PROMINENT LOCATION THE INSTRUCTIONS TO BE FOLLOWED IN THE EVENT THE USER SMELLS GAS. THIS INFORMATION SHALL BE OBTAINED BY CONSULTING THE LOCAL GAS SUPPLIER.

THIS EQUIPMENT IS TO BE INSTALLED IN COMPLIANCE WITH THE BASIC PLUMBING CODE OF THE BUILDING OFFICIALS AND CODE ADMINISTRATORS INTERNATIONAL, INC. (BOCA) AND THE FOOD SERVICE SANITATION MANUAL OF THE FOOD AND DRUG ADMINISTRATION.

COMPUTERS
FCC

This device complies with Part 15 of the FCC rules. Operation is subject to the following two conditions:
1) This device may not cause harmful interference, and 2) This device must accept any interference received, including interference that may cause undesired operation. While this device is a verified Class A device, it has been shown to meet the Class B limits.

CANADA

This digital apparatus does not exceed the Class A or B limits for radio noise emissions as set out by the ICES-003 standard of the Canadian Department of Communications.

Cet appareil numerique n'emet pas de bruits radioelectriques depassany les limites de classe A et B prescrites dans la norme NMB-003 edictee par le Ministre des Communcations du Canada.

⚠ DANGER

THIS PRODUCT CONTAINS CHEMICALS KNOWN TO THE STATE OF CALIFORNIA TO CAUSE CANCER AND/OR BIRTH DEFECTS OR OTHER REPRODUCTIVE HARM.

Operation, installation, and servicing of this product could expose you to airborne particles of glasswool or ceramic fibers, crystalline silica, and/or carbon monoxide. Inhalation of airborne particles of glasswool or ceramic fibers is known to the State of California to cause cancer. Inhalation of carbon monoxide is known to the State of California to cause birth defects or other reproductive harm.

FRYMASTER FRYERS EQUIPPED WITH LEGS ARE FOR PERMANENT INSTALLATION. FOR MOVEABLE OR PORTABLE INSTALLATION, FRYMASTER OPTIONAL EQUIPMENT CASTERS MUST BE USED.

QUESTIONS??? CALL 1-800-551-8633.

Do not use deliming solution to clean water bath units. Use of deliming solution will damage all stainless steel parts.

GAS COOKERS GSMS, GBC AND GC SERVICE & PARTS MANUAL TABLE OF CONTENTS

CHAPTER 1: Service Procedures

1.1	Functional Description.....	1-1
1.2	Accessing Equipment for Servicing.....	1-2
1.3	Replacing Equipment Components.....	1-3
1.3.1	Replacing the Controller.....	1-3
1.3.2	Replacing Electronic Components Other than the Controller.....	1-3
1.3.3	Replacing a Water-Level Sensor or the Temperature Probe.....	1-4
1.3.4	Replacing the Pressure Regulator or Solenoid Valve.....	1-5
1.3.5	Replacing the Water Faucet.....	1-5
1.3.6	Replacing a Basket Lift Motor or Microswitch.....	1-6
1.3.7	Replacing Gas Supply System Components or Ignitor Assemblies.....	1-7
1.3.8	Replacing the Cookpot or Rinse Tank.....	1-8
1.4	Troubleshooting.....	1-9
1.4.1	How the Power Supply System Works.....	1-9
1.4.2	How the Controller Works.....	1-9
1.4.3	How the Autofill/Autoskim System Works.....	1-10
1.4.4	How the Water Heating System Works.....	1-10
1.4.5	How the Basket Lift System Works.....	1-11
1.4.6	Technician Troubleshooting Guides.....	1-11
1.4.7	Probe Resistance Chart and Wiring Diagrams.....	1-15

CHAPTER 2: Parts List

2.1	Accessories.....	2-1
2.2	Basket Lift Components.....	2-2
2.3	Cabinetry.....	2-4
2.4	Combustion System Components.....	2-8
2.5	Control Box and Related Components.....	2-10
2.6	Controllers and Control Panel Components.....	2-12
2.7	Cookpot, Rinse Tank and Associated Components.....	2-13
2.8	Drain Components.....	2-15
2.9	Gas Supply System Components.....	2-16
2.10	Water Supply Components.....	2-18

Appendix A: Notes Concerning and Parts Unique to GSW/GWB Variants

Accessories.....	A-1
Control Components.....	A-2
Service Cookpot.....	A-3
Water Supply Components.....	A-4
Wiring Diagrams.....	A-6

GAS COOKERS GSMS, GBC, AND GC SERVICE AND PARTS

CHAPTER 1: SERVICE PROCEDURES

1.1 Functional Description

The GSMS, GBC, and GC Gas Cookers all have a 12.7-gallon (48.1-liter) stainless steel cookpot. The water in the cookpot is heated by a high-efficiency infrared heating system that requires approximately 43% less energy than conventional burner systems to heat the same volume of water.

Two self-contained combustion chambers (commonly referred to as burners) are located beneath the cookpot. Each combustion chamber is fitted with special ceramic tiles that are heated by the burning of a forced air/gas mixture. The tiles transfer their heat to the cookpot by means of infrared radiation, providing much more constant and uniform heat dispersion over the surface of the cookpot than do conventional burners. Because relatively less heat is lost to the atmosphere in the process, compared to “open-burner” designs, less fuel is required to achieve and maintain a given cookpot temperature.

Gas flow to both of the burners is regulated by one electromechanical gas valve.

Operational control of the burner system is accomplished through a solid-state SMS III *Spaghetti Magic* controller. **NOTE:** The SMS III controller used in this model series is identical in appearance to the SMS III controllers used in other model series, but differs internally. *Use only the part numbers listed in Chapter 2 when replacing controllers on this equipment.* The GSMS is equipped with a basket lift, and also features automatic filling (Autofill), automatic skimming (Autoskim), a swing-away jointed faucet, and an attached 16.5-gallon (62.5-liter) rinse-tank. The GBC model is identical to the GSMS except that it does not have the swing-away faucet and attached rinse-tank. The GC has no basket lift, no faucet, and no rinse tank.

When the controller Power switch is pressed, a logic circuit in the controller automatically checks the water level in the cookpot. A normally closed solenoid valve on the water supply line automatically opens if the normal water-level sensor is not grounded by contact with water in the cookpot. When sufficient water has been added to ground the low water-level sensor, the unit automatically enters the **SIMMER** mode and remains there unless the operator presses the **BOIL** mode switch or turns the unit off. When the water level in the cookpot reaches and grounds the normal water-level sensor, the solenoid valve in the water supply line closes. Anytime the water level in the cookpot drops below the normal water-level sensor, the solenoid valve opens to refill the cookpot to the proper level.

While in the SIMMER mode, logic circuits in the controller monitor the temperature of the water and cycle the burners on and off to maintain the temperature at the setpoint programmed into the controller. (See Chapter 3 for instructions on adjusting the setpoint.) The cooker also has low-water safety. If the water in the cookpot falls below the low water-level sensor, the controller cuts power to the gas valve, causing it to close and cut off the gas supply to the burners.

The Autoskim feature (on units so equipped) is activated by pressing the Skim switch. When the feature is activated, a logic circuit in the controller automatically opens the solenoid valve in the

water supply line for three seconds every minute until the option is turned OFF by again pressing the Skim switch.

The operator enters a specified cooking time by pressing the number pads on the controller. When the Start switch is pressed, the controller begins to count down to zero. When the controller times out, an alarm sounds briefly, then the timer reverts to the last time entered.

When the START switch is pressed to start the cooking cycle, logic circuits in the controller activate the basket lift motors (on units so equipped), lowering the basket into the cookpot. As the motors drive the basket lift arms down, a cam attached to the left motor eventually loses contact with a roller-activated microswitch and power to the motors is cut. When the controller times out, logic circuits reverse the switch positions so that the motor circuit is again completed and the motors are restarted, raising the basket from the cookpot. At the fully raised position, the cam again makes contact with the microswitch, cutting power to the motors and stopping the lift in the up position.

THE ELECTRONIC IGNITION SYSTEM

The ignition module, located in the component box, is connected to ignitor assemblies at each burner. The ignition module performs three important functions: it provides an ignition spark, supplies operating voltage to the gas valve, and proofs the burner flame. **NOTE:** GSMS/GBC/GC units manufactured before September 2000 have two single-spark ignition modules. Those manufactured September 2000 and later have only one dual-spark ignition module.

The ignition module contains a 4-second time delay circuit and a coil that activates the gas valve. The ignitor assembly consists of a spark plug, an enrichment tube, and flame sensor.

At start-up, the controller power switch is placed in the ON position, supplying approximately 12-volts DC to the heat control circuitry in the controller. If the controller senses the correct operating parameters (i.e., the correct water level in the cookpot), it sends a signal to the 24VAC relay in the component box to close the blower contacts. This supplies line voltage to the blower motor. A centrifugal switch in the blower closes if the blower is operating correctly, which allows 24VAC to flow through the closed contacts of the 24VAC relay to the ignition module.

Circuitry in the ignition modules sends 24VAC to the gas valve. Simultaneously, the module causes the ignitors to spark for 4 seconds to light the burners. A flame sensor for each burner verifies that the burner is lit by measuring the flow of microamps through the flame. If the burner does not light (or is extinguished), current to the ignition module is cut, preventing the gas valve from opening, and the ignition module “locks out” until the controller power switch is turned off and then back on.

A probe monitors the temperature in the cookpot. When the programmed setpoint temperature is reached, resistance in the probe causes the heat cycle circuitry in the controller to cut off current to the 24VAC relay, thus cutting line voltage to the blower. This cuts the 24VAC to the ignition module, causing the gas valve to close.

1.2 Accessing Equipment for Servicing

DANGER

Moving this equipment while it is filled with hot water may cause spilling or splattering of the hot water. Always drain the cookpot before attempting to relocate this equipment for servicing.

1. Disconnect the unit from the electrical power supply, the gas supply and the water supply.
2. Disconnect any attached restraining devices.
3. Relocate the unit for service accessibility.
4. After servicing is complete, reconnect the unit to the water supply and the gas supply. Reattach the restraining devices, and reconnect the unit to the electrical power supply.

1.3 Replacing Equipment Components

1.3.1 Replacing the Controller

1. Open the control panel by removing the screws in the upper edge of the panel. Swing the panel down and disconnect the 15-pin connector, trouble light wires, and ground wire. Remove the control panel by lifting the panel out of the slots in the control panel frame.
2. Remove the failed controller from the control panel and replace with the new controller. Reverse Step 1 to complete the process.

1.3.2 Replacing Electronic Components Other than the Controller

1. Drain the cookpot and disconnect the cooker from the electrical power supply.
2. Remove the control panel in accordance with Step 1 of Section 1.3.1.
3. Remove the lower cover from the component box. Refer to the illustration below to locate the component to be replaced.

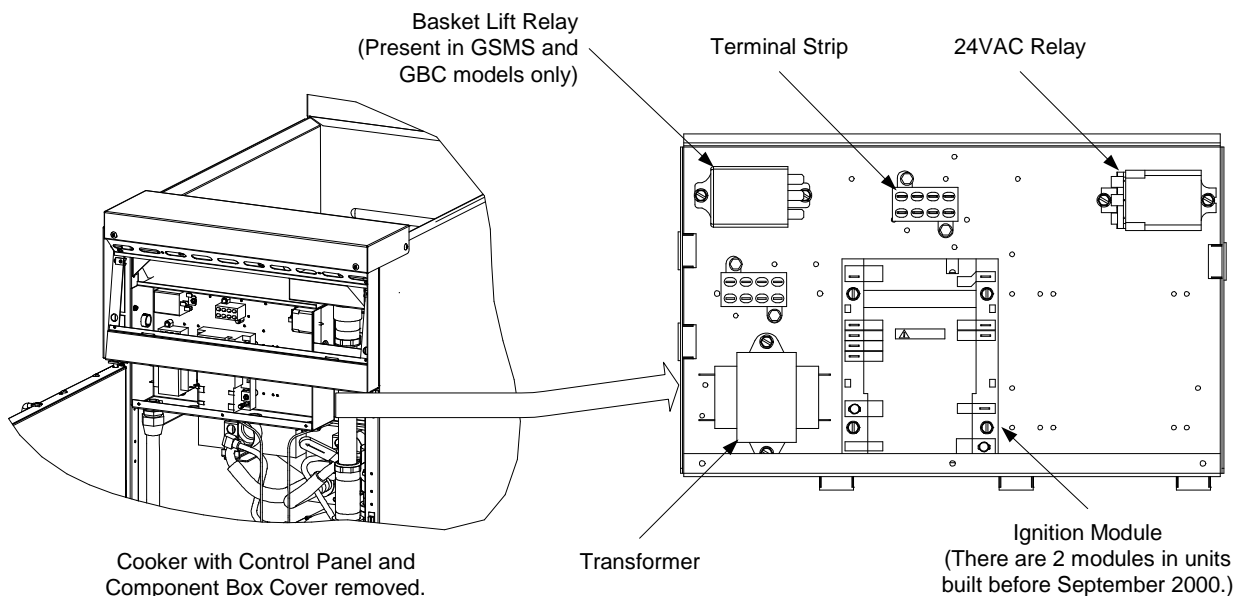

NOTE: Wiring not show to provide a clearer view.

4. On the component to be replaced, make a note of the wiring connection points. Disconnect the wires and remove the failed component. Install the replacement component and reconnect the wiring in accordance with the notes made, or with the wiring diagram on the door of the unit.

5. Replace the component box cover, and reinstall the controller being sure to reconnect the ground wire and trouble light wires. Reconnect the cooker to the electrical power supply.

1.3.3 Replacing a Water-Level Sensor or the Temperature Probe

1. Drain the cookpot and disconnect the cooker from the electrical power supply.
2. Remove the screws in the upper edge of the control panel and swing the panel down. Disconnect the 15-pin connector, trouble light wires, and ground wire, and lift the panel out of the slots in the control panel frame.
3. Remove the topcap from the unit by removing the four screws (two on the front and two on each end) that secure it to the cabinet.
4. Remove the control panel frame by removing the screws in the top and bottom corners and, on GSMS units, the screw in the center bracket.
5. If replacing a water-level sensor (see illustration below):
 - a. Disconnect the sensor lead by pulling it from its terminal then remove the Keps nut, terminal, and washer from the sensor.
 - b. Inside the cookpot, remove the screw from the sensor flange.
 - c. Carefully pull the failed sensor from the probe block and replace with the new sensor.
 - d. Reassemble the washer, terminal, and Keps nut onto the sensor, and reattach the lead.
 - e. Reverse Steps 1-4 to complete the procedure.

If replacing the temperature probe, mark the wiring harness leads and disconnect the probe leads at the push on connectors.

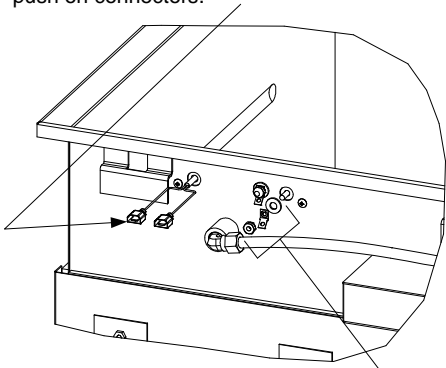

If replacing a water-level sensor, disconnect its lead and remove its Keps nut, terminal and washer.

Remove the screws from the probe bracket and push the probe out the back of the probe block.

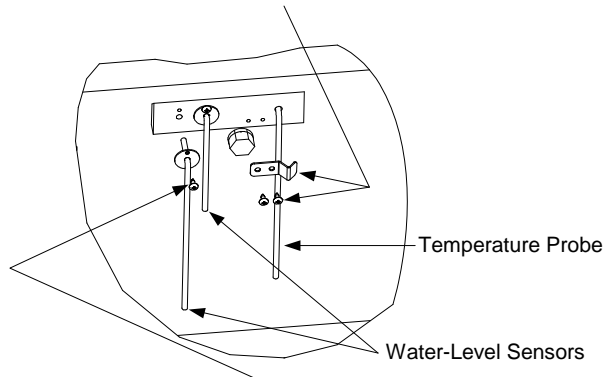

Remove the screw from the sensor flange and pull the sensor out the front of the probe block.

6. If replacing the temperature probe (see illustration above):
 - a. Mark the wiring harness leads and disconnect them from the probe leads at the push-on connectors.
 - b. Remove the two screws in the probe bracket.
 - c. Carefully pull the probe from the probe block and replace with the new probe.
 - d. Reattach the leads and reverse Steps 1-4 to complete the procedure.

1.3.4 Replacing the Pressure Regulator or Solenoid Valve

1. Drain the cookpot and disconnect the cooker from the electrical power supply. Turn off or disconnect the water supply to the cooker.
2. Disconnect the solenoid leads at the push-on connectors. Disconnect solenoid and regulator subassembly at the compression fittings on the water lines running to and from these components. Remove the two screws in the mounting bracket and remove the solenoid and regulator subassembly from the unit. (**NOTE:** If the cooker is not equipped with the optional Autofill feature, the cookpot water tube will be connected directly to the regulator and there will be no solenoid valve.)

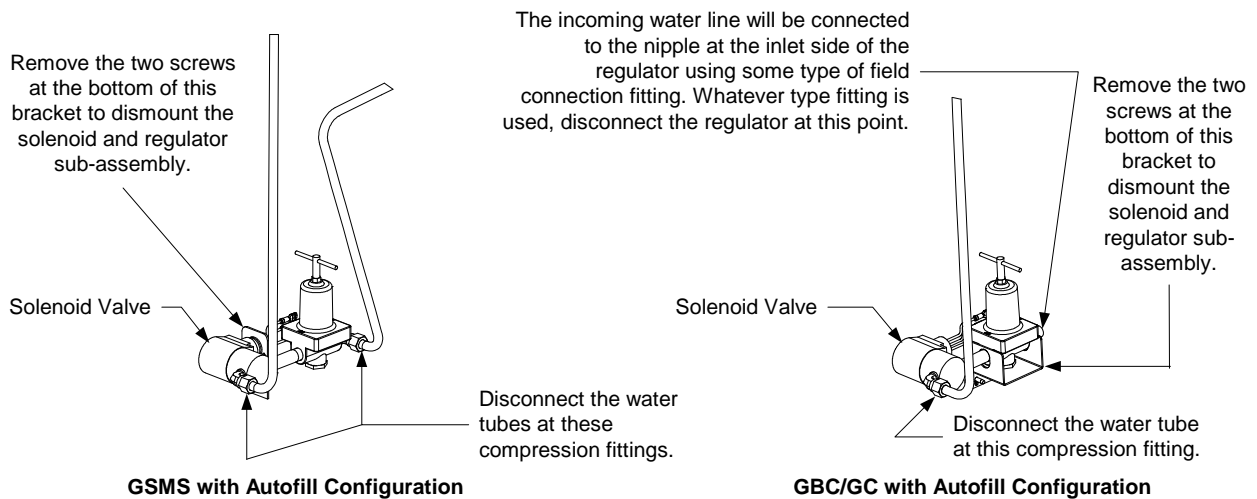

3. If replacing the regulator, adjust the replacement regulator output pressure to not more than 40 PSI (28.15 kg/cm²) before installation in the cooker.
4. Recover the fittings from the failed component (regulator or solenoid valve) and install them on the replacement, using thread sealer on all connections.
5. Reverse Steps 1 and 2 to complete the procedure, being sure to apply thread sealer to all connections.

1.3.5 Replacing the Water Faucet

1. Drain the cookpot and disconnect the cooker from the electrical power supply.

NOTE: Refer to the illustration at the top of Page 1-6 for the following steps.

2. Turn off the water supply to the cooker and disconnect the incoming water lines where they attach to the stubs at the rear of the cooker.
3. Remove the two screws securing the access panel in place and remove the panel.
4. Disconnect the water supply line at the compression fitting where it attaches to the water inlet manifold. Remove the screws from the faucet mounting plate and lift the faucet assembly from the unit.

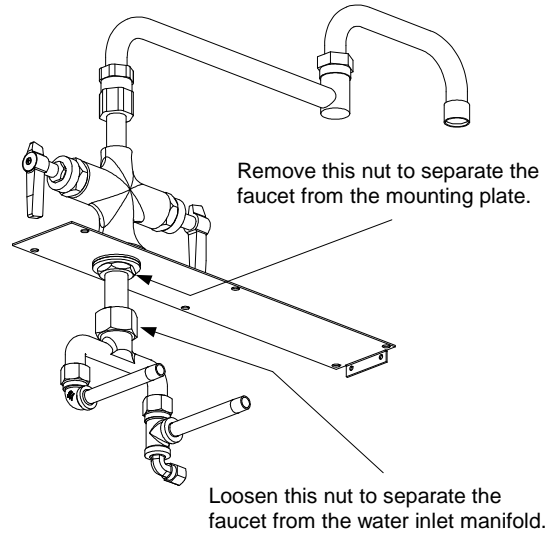
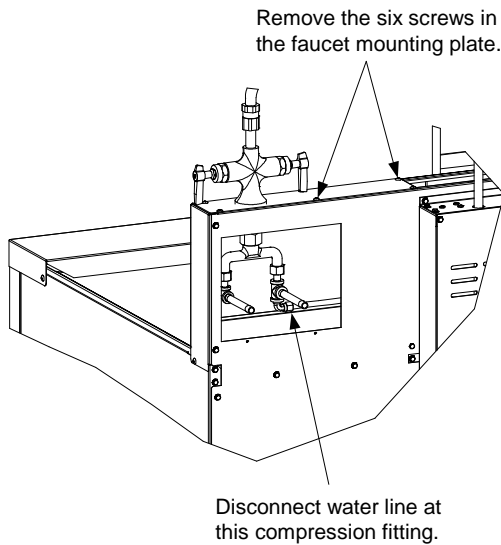

5. Separate the faucet from the water inlet manifold and mounting plate as shown in the illustration above.
6. Reverse Steps 1-5 to complete the procedure.

1.3.6 Replacing a Basket Lift Motor or Microswitch

1. Disconnect the cooker from the electrical power supply.
2. If rigid water connections have been used, disconnect the cooker from the incoming water supply.
3. Remove the basket lift arms from the lifter rods and then reposition the cooker to gain access to the rear. Remove the upper and lower basket lift rear panels.
4. Disconnect the basket lift synchronizer link from the lifter cam (bell crank) assemblies one at a time. When the link is disconnected from a cam, slip the corresponding lifter rod down and out of the assembly (see illustration on below).

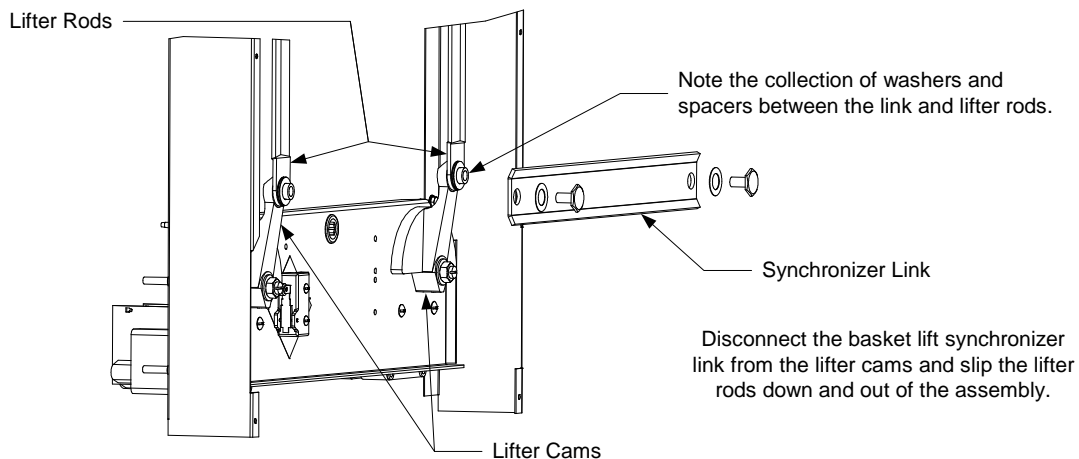

- Remove the four bolts securing the motor mount to the frame, then remove the motor and mount assembly from the unit. **NOTE:** It is possible to replace a motor or the microswitch without removing the motor and mount assembly, but it is much more difficult.
- Dismount the motor or microswitch as shown below and install the replacement.

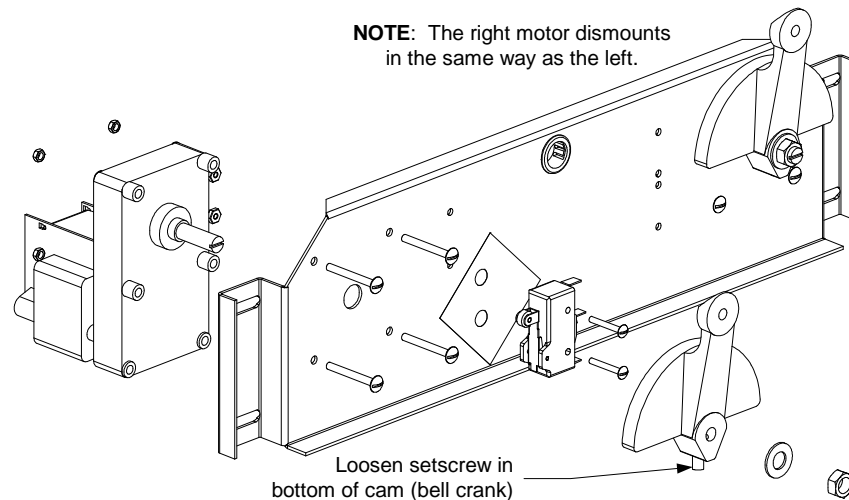

- Reverse Steps 1-6 to complete the procedure.

1.3.7 Replacing Gas Supply System Components or Ignitor Assemblies

- Disconnect the cooker from the electrical power supply and from the gas supply. If necessary, disconnect restraints to gain proper access to components.
- Disconnect the component to be replaced (see illustration below) and install the replacement component. **NOTE:** If replacing the gas valve, disconnect the enrichment tubes and gas supply tubes at the valve, then unscrew the valve from the mounting bracket. Recover the fittings from the failed valve and install them on the replacement valve using a thread sealer suitable for gas appliances (Loctite™ PST 56765 is one example). Do not apply the sealer to the first two threads of the fitting. This will help prevent clogging of the burner orifices and gas valve.

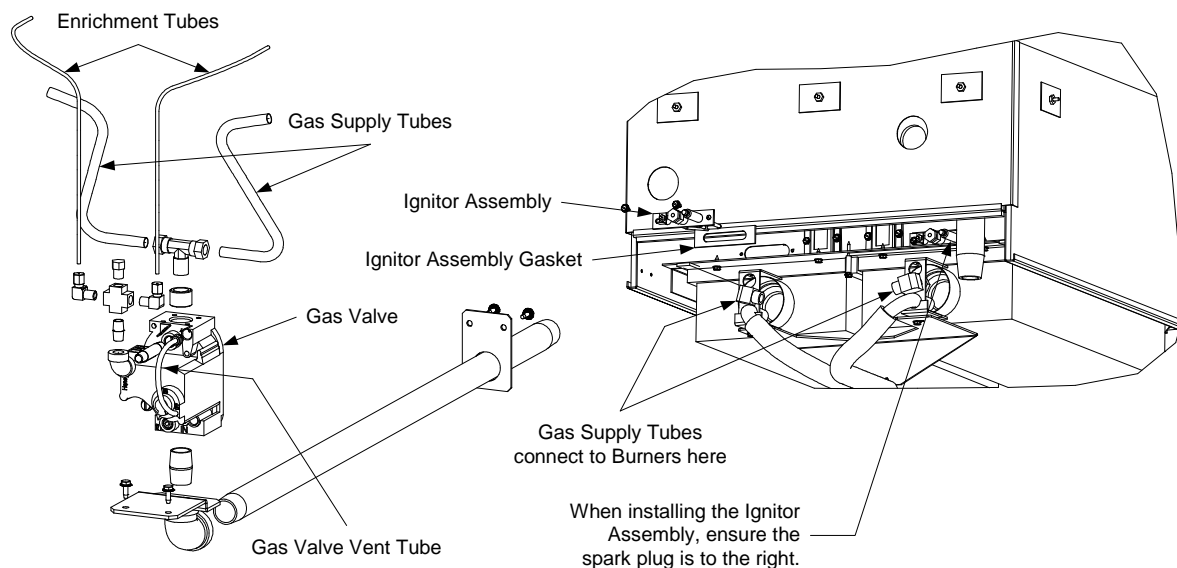

- Reconnect the cooker to the gas supply and check all connections for leaks using a solution of soapy water.

⚠ DANGER
DO NOT use matches, candles, or other ignition methods to check for leaks.

- When satisfied that there are no leaks, reconnect the unit to the electrical supply, and reconnect any restraints disconnected in Step 1.

1.3.8 Replacing the Cookpot or Rinse Tank

NOTE: The following procedure addresses removing the cookpot or rinse tank from a GSMS unit. The procedure is essentially the same for a GBC or GC unit, except that there is no faucet, and on the GC unit, no basket lift.

- Remove the basket lift arms from the lifter rods.
- Remove the faucet assembly from the cooker in accordance with Steps 1-4 of Section 1.3.5.
- Remove the screws that secure each of the rear corners of the backsplash assembly (see illustration at right). **NOTE:** To access the screw in the lower right corner (as viewed from the rear) the upper basket lift back panel must be removed.
- Remove the screws along the top edge of the control panel and open the panel by swinging it downward. Disconnect the 15-pin connector from the rear of the controller and the wires attached to the trouble light, and then lift the control panel out of the control panel frame.
- Remove the screws that secure the backsplash sides to the cabinet sides then remove the four screws that secure the topcap to the cabinet.
- Remove the top connecting strip.
- Remove the screws attaching the standoff brackets to the cookpot or rinse tank.
- If removing the cookpot, disconnect the enrichment tubes and gas supply tubes from the burner assemblies. Disconnect the ignition cables and flame sensor wires from the ignitor assemblies on each burner.
- Lift the cookpot or rinse tank straight up and out of the cabinet.

Remove these four screws.

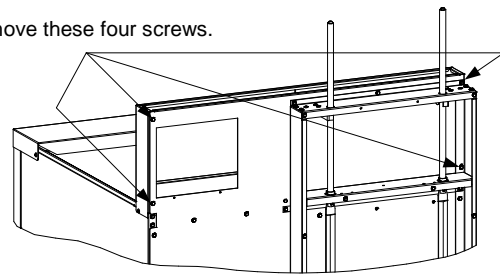

Remove these screws (on both sides) and remove backsplash and topcap.

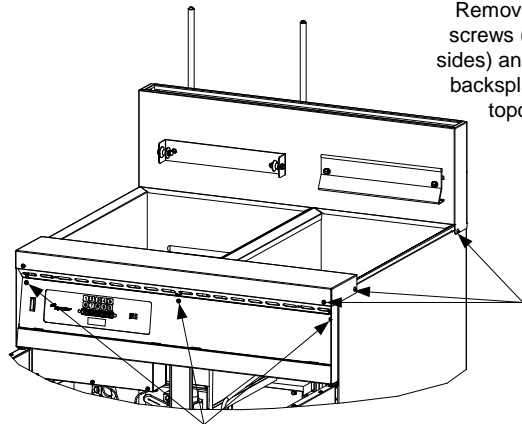

Remove screws along the top edge of control panel and dismount the panel.

Remove these screws to release the pots from the standoff brackets.

Remove the top connecting strip.

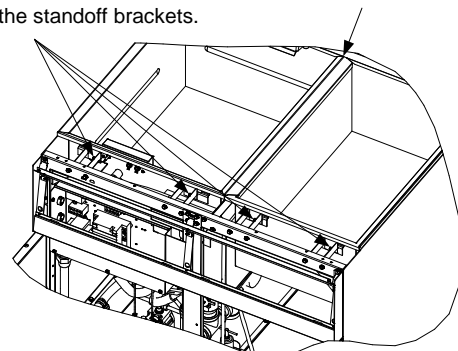

10. Invert the cookpot or rinse tank on a suitable work surface and remove the salvageable components (e.g., probe block assembly, blower assembly, drain plumbing, etc.). Install the recovered components on the replacement cookpot or rinse tank, using thread sealer on all connections.
11. Reverse Steps 1 through 9 to complete the procedure.

1.4 Troubleshooting

Problems with this equipment maybe grouped into five broad categories:

1. Failure or malfunction of a Power-Supply System component.
2. Failure or malfunction of the Controller.
3. Failure or malfunction of an Autofill/Autoskim System component.
4. Failure or malfunction of a Water Heating System component.
5. Failure or malfunction of a Basket Lift System component.

Sections 1.4.1 through 1.4.5 briefly explain the functioning of each of the systems mentioned above. Section 1.4.6 contains troubleshooting guides that provide systematic procedures to isolate and identify the specific source of a problem. A wiring diagram is located at the end of the chapter.

1.4.1 How the Power-Supply System Works

Line voltage is supplied to the system via a power cord that is plugged or hard-wired into the store's electrical service. The power cord is connected to pins 1 and 5 of an 8-pin terminal block. Line voltage is supplied to a 24VAC transformer from pins 2 and 8 of the terminal block. Pin 7 supplies 24VAC to a heat relay, which controls line voltage to the blower motor and 24VAC to the gas valve via the ignition module. The transformer supplies 24VAC to the controller, to the coils of the 24VAC relay, and to the solenoid valve on units equipped with the Autofill option. On units equipped with basket lifts, line voltage is supplied to a 24VDC basket lift relay from pin 6 of the power cord terminal block. Line voltage to the basket lift motors is supplied via the basket lift relay.

1.4.2 How the Controller Works

The SMS III controller provides the interface between the operator and the system components. The controller is powered by 24VAC supplied through Pins 1 and 2 of the wiring harness. Internal circuitry senses the water level and water temperature. Depending upon the conditions sensed, the controller energizes or de-energizes the solenoid valve to control water level and the 24VAC relay to control burner firing to control water temperature. The controller also controls the lowering and raising of the basket lift, and activates an audible alarm to signal the operator that a cooking cycle has completed. A rectifier in the controller converts 24VAC to the 24VDC required by the basket lift relay. The controller signals for heat via Pin 4, grounds the solenoid valve via Pin 6, and senses water level via Pins 7 (low) and 9 (full). The temperature probe connects to Pins 13 and 14. The basket lift relay connects to Pins 10 and 12. The sound device connects to Pin 11.

1.4.3 How the Autofill/Autoskim System Works

The heart of the automatic filling (Autofill) system is a normally closed solenoid valve that opens when 24VAC is applied.

The ground for the solenoid is supplied (via Pin 6 of the controller wiring harness) so long as the shorter of the two water-level sensors is not in contact with the water in the cookpot. When the water in the cookpot reaches the shorter of the two water-level sensors, the sensor is grounded. This causes the controller to break the solenoid ground, closing the valve. Starch or lime build-up on the sensor may keep it from grounding, therefore always make sure the sensor is clean and its lead (Pin 9 of the controller wiring harness) is firmly connected. Also, in order for the sensor to ground, there must be some mineral content in the water (pure water is non-conductive). Consequently, the unit will not operate correctly with distilled, highly filtered, or deionized water. If water of these types is used, add 1/8-cup of baking soda to the water each time the cookpot is emptied and refilled. **NOTE:** Do not use deliming solution to clean these units. Use of deliming solution will damage all stainless steel parts.)

On units equipped with the Autoskim feature, a logic circuit in the controller automatically opens the solenoid valve for three seconds every minute. If the Autofill feature is working properly, failure of the Autoskim feature will be due to a malfunctioning controller and not the solenoid valve. (Proper operation of the Autofill feature can be determined by draining water from the cookpot until the water level is below the shorter of the two water-level sensors. If the solenoid valve opens and then closes when the water in the cookpot again reaches the sensor, the Autofill feature is working properly.)

1.4.4 How the Water Heating System Works

To prevent lighting the burners when there is no water in the cookpot, these units are equipped with a **low-water-level sensor** (the longer of the two water-level sensors). This sensor must be grounded by contact with water in the cookpot before the control circuitry will allow firing of the burners. Starch or lime build-up on the low-water-level sensor may keep the sensor from grounding, therefore always make sure the sensor is clean and its lead (Pin 7 of the controller wiring harness) is firmly connected. Also, in order for the sensor to ground, there must be some mineral content in the water (pure water is non-conductive). Consequently, the unit will not operate correctly with distilled, highly filtered, or deionized water. If water of these types is used, add 1/8-cup of baking soda to the water each time the cookpot is emptied and refilled. **NOTE:** Do not use deliming solution to clean these units. Use of deliming solution will damage all stainless steel parts.)

In addition to the low-water-level sensor discussed above, the water heating system has three more parts: the electronic ignition system, the temperature probe, and the controller.

The **electronic ignition system** controls firing of the burners. See Page 1-2 for a complete description of this system.

The **temperature probe** is used only when the unit is in the simmer mode. When the simmer mode is selected, logic circuits in the controller monitor the temperature of the water. When the water temperature drops below the simmer setpoint, the controller closes the heat relay, causing the burners to fire. When the water temperature reaches the setpoint, the controller opens the heat relay,

extinguishing the burners. This process repeats as required to maintain the temperature at the setpoint programmed into the controller.

The **controller** is the interface between the operator and the other components of the equipment. In the water heating system, its function is to control the firing of the burners.

1.4.5 How the Basket Lift System Works

When the Start switch is pressed to start the cooking cycle, logic circuits in the controller activate the basket lift motors, lowering the basket into the cookpot. As the motors drive the basket lift arms down, a cam attached to the left motor (when viewed from the rear) eventually loses contact with a roller-activated microswitch and power to the motors is cut. When the controller times out, logic circuits reverse the switch positions so that the motor circuit is again completed and the motors are restarted, raising the basket from the cookpot. At the fully raised position, the cam again makes contact with the microswitch, cutting power to the motors and stopping the lift in the raised position.

1.4.6 Technician Troubleshooting Guides

PROBLEM	PROBABLE CAUSES	CORRECTIVE ACTION
Autofill does not add water when water level is below the normal water-level sensor (the shorter of the two water-level sensors).	A. Water not turned on.	A. Turn on Water
	B. Failed solenoid, failed computer, or loose/broken wiring. Test: Check for at least 22VAC at Pin 5 of the 24VAC terminal block and at solenoid end of wire 66C, and check for ground (0 voltage) at Pin 6 of 15-pin connector.	B. If voltage is present at solenoid end of wire 66C, and Pin 6 of 15-pin connector is grounded (0 voltage present), check continuity of wire 50C. If wire 50C is good, replace solenoid. If voltage is present at solenoid end of wire 66C and at Pin 6 of 15-pin connector, replace controller. If voltage is not present at solenoid end of wire 66C, check wiring between solenoid and terminal block for loose connection or break in the wire.
Autofill does not shut off when the cookpot is full.	A. Starch accumulation on the normal water-level sensor (the shorter of the two water-level sensors) is preventing the sensor from grounding.	A. Clean the water-level sensors. NOTE: Do not use deliming solution.
	B. Mineral content of water is too low to provide a ground.	B. Add 1/8 th cup of baking soda to water in cookpot. DO NOT USE SALT! Doing so will damage the cookpot.
Continued on following page.		

PROBLEM	PROBABLE CAUSES	CORRECTIVE ACTION
Continued from previous page.	<p>C. Failed solenoid, failed computer, or broken/loose wiring.</p> <p>Test 1: Check sensor-lead connections on outside of cookpot and at Pin 9 of 15-pin connector and continuity of wire 71C.</p> <p>Test 2: Check for AC voltage at Pin 6 of 15-pin connector.</p> <p>Test 3: Check for at least 22VAC at solenoid end of wire 66C.</p>	<p>C. Action 1: Tighten connections or replace wiring as required.</p> <p>Action 2: If AC voltage is not present, replace controller.</p> <p>Action 3: If AC voltage is present, replace solenoid.</p> <p>If AC voltage is not present, check wiring between solenoid and terminal block for loose connection or break in the wire.</p>
Autoskim does not add water when selected (Autofill feature verified to be working correctly).	A. Failed controller.	A. Replace controller.
Basket lift does not lower when START button is pressed or rise when cooking cycle completes.	A. Failed basket lift relay.	A. If voltages are correct, replace relay.
	B. Failed controller.	B. Replace controller if voltage is below 12VDC.
Basket lift travels up and down continuously.	<p>C. Failed or out of adjustment microswitch.</p> <p>Test: Check continuity of switch and verify that roller contacts cam.</p>	<p>A. Replace switch if it fails continuity check.</p> <p>Adjust switch mounting to ensure roller contacts cam.</p>
Basket lift travels erratically or with jerking motion.	A. Bell crank slipping on shaft.	A. Tighten bell crank setscrew. Ensure nut and locknut on shaft are tight.
	B. Lift arms binding in bushings	B. Lubricate lift arms.
	C. Defective motor.	C. Replace motor.
Burner attempts to light but will not remain lit.	A. Flame sensor wire and ignitor cables crossed.	A. Verify that Sense 1 and Spark 1 connect to same ignitor.
Burner will not light; trouble light is on.	A. Cooker gas valve is turned off.	A. Turn gas valve on.
	B. Incoming gas line shut-off valve is closed.	B. Open incoming gas line shut-off valve.

PROBLEM	PROBABLE CAUSES	CORRECTIVE ACTION
Burner will not light; trouble light is NOT on, blower is NOT running.	A. Failed 24VAC (blower) relay. Test: Check for 24VAC on Pin 4 of 15-pin connector.	A. If voltage is present, replace relay.
	B. Failed controller.	B. Replace controller.
Burner will not light; trouble light is ON, blower is running continuously.	A. Failed blower centrifugal switch. Test: Check for 24VAC at bottom 24VAC terminal of ignition module (wire 7C).	A. If voltage is not present, replace blower.
	B. Failed ignition module or gas valve. Test: Check for 24VAC output from module to gas valve, and for high voltage spark from module to ignitor.	B. If either is not present, replace the module. If both are present, replace the gas valve.
Burner produces popping sound when lighting.	A. Dirty blower inlet and fan.	A. Clean blower.
	B. Vent tube on gas valve is clogged, causing high burner gas pressure.	B. Remove and clean vent tube.
	C. Cracked/broken ceramic tiles in burner.	C. Replace burner.
	D. Failed ignitor.	D. Replace ignitor.
Controller display is blank.	A. Controller not turned on.	A. Turn on controller.
	B. Cooker power cord not plugged in.	B. Plug power cord into appropriate outlet.
	C. Main circuit breaker tripped.	C. Reset main circuit breaker.
	D. Failed transformer. Test: Check for 24VAC on transformer secondary.	D. If voltage is incorrect, replace transformer.
	E. Failed controller.	E. Replace controller.
Controller does not count down.	A. Operator error. Test: Verify correct cook time is programmed. Press START button.	A. Demonstrate proper operating procedure to operator.
	B. Failed controller. Test: Verify correct cook time is programmed. Press the START button.	B. If timer does not count down, replace controller.

PROBLEM	PROBABLE CAUSES	CORRECTIVE ACTION
Water boils in simmer mode.	A. Controller out of calibration.	A. Recalibrate simmer setpoint.
	B. Failed/shorted temperature probe. Test: Check for shorted probe circuit. Probe resistance should be approximately 552 Ohms @ 60°F (16°C), 655 Ohms @ 100°F (38°C), and 1000 Ohms @ 212°F (100°C). See probe resistance chart on page 1-15 for other temperatures.	B. If resistance is out of specification, replace the temperature probe.
Water temperature too low in simmer mode.	A. Controller out of calibration	A. Recalibrate simmer setpoint.
	B. Temperature probe open. Test: Check for loose connections.	B. If connections are secure, replace temperature probe.

1.4.6 Benchmark Probe Resistance Readings Chart and Wiring Diagrams

Temperature °F	Temperature °C	Resistance
65	18	694 Ω ± 5
75	24	717 Ω ± 5
85	29	741 Ω ± 5
195	90.5	949 Ω ± 5
212	100	1000 Ω ± 5

WIRING DIAGRAMS

FOR UNITS WITH A SINGLE DUAL-SPARK IGNITION MODULE

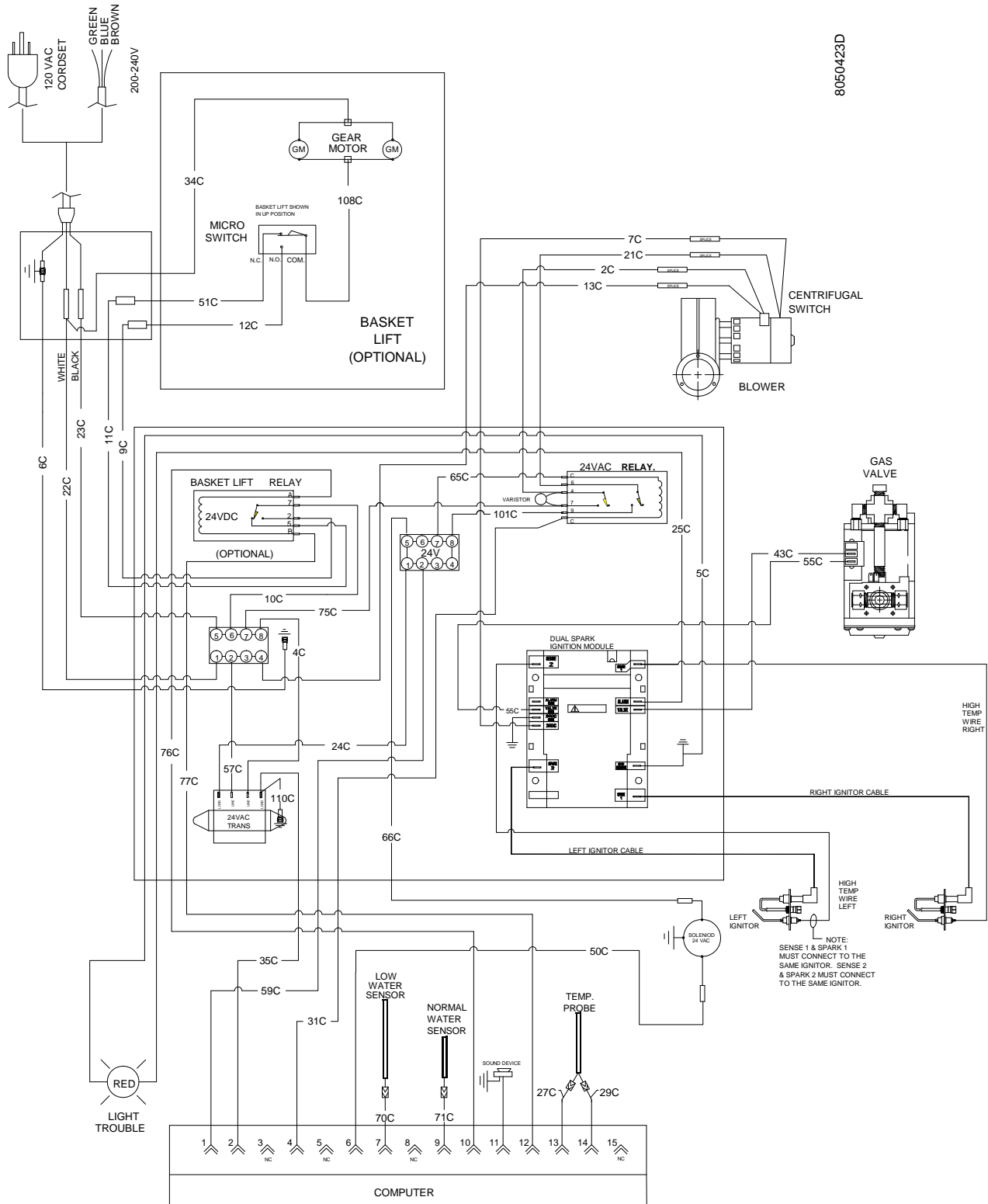

8050423D

FOR UNITS WITH TWO SINGLE-SPARK IGNITION MODULES

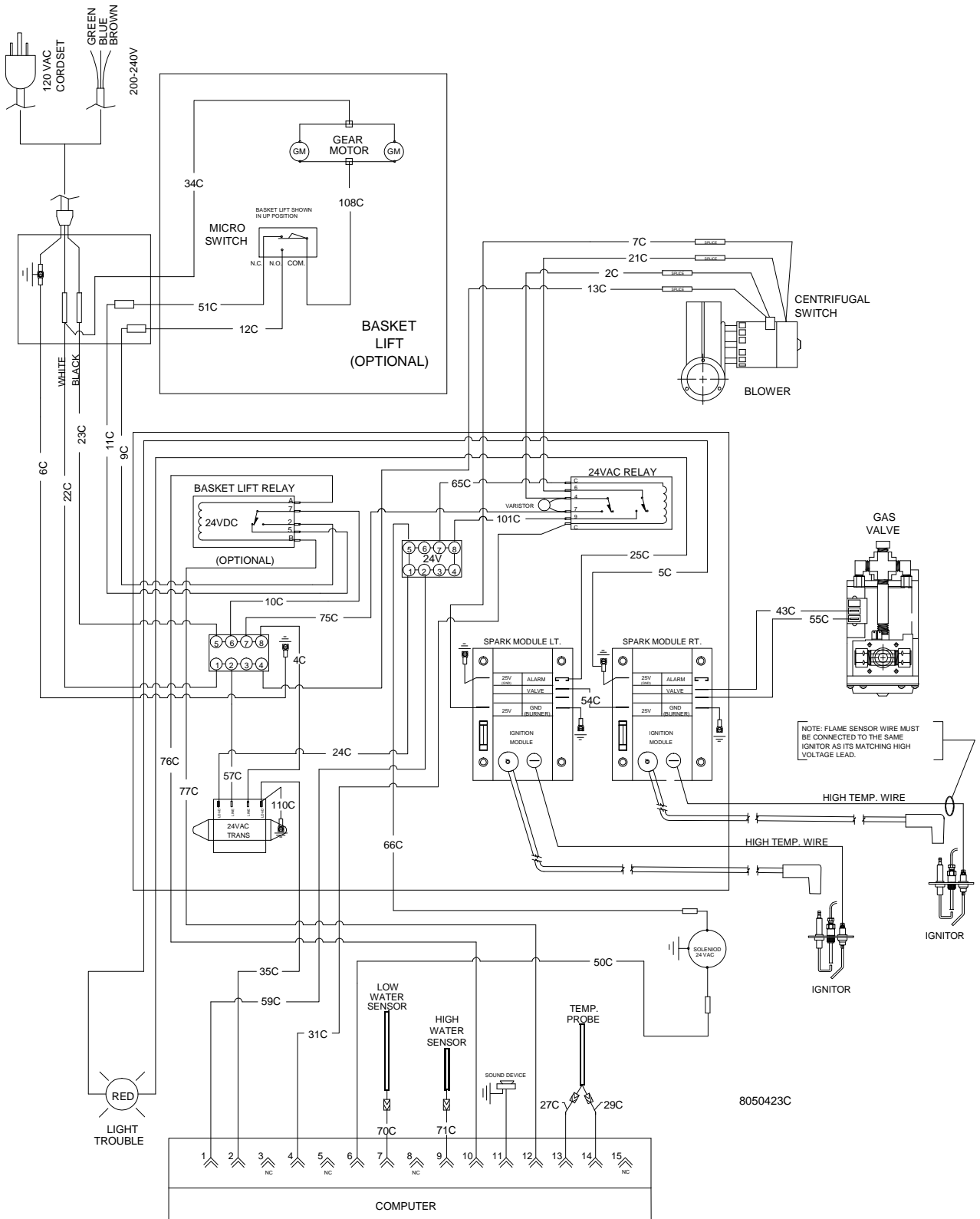

GAS COOKERS GSMS, GBC, AND GC SERVICE AND PARTS

CHAPTER 2: PARTS LIST

2.1 Accessories

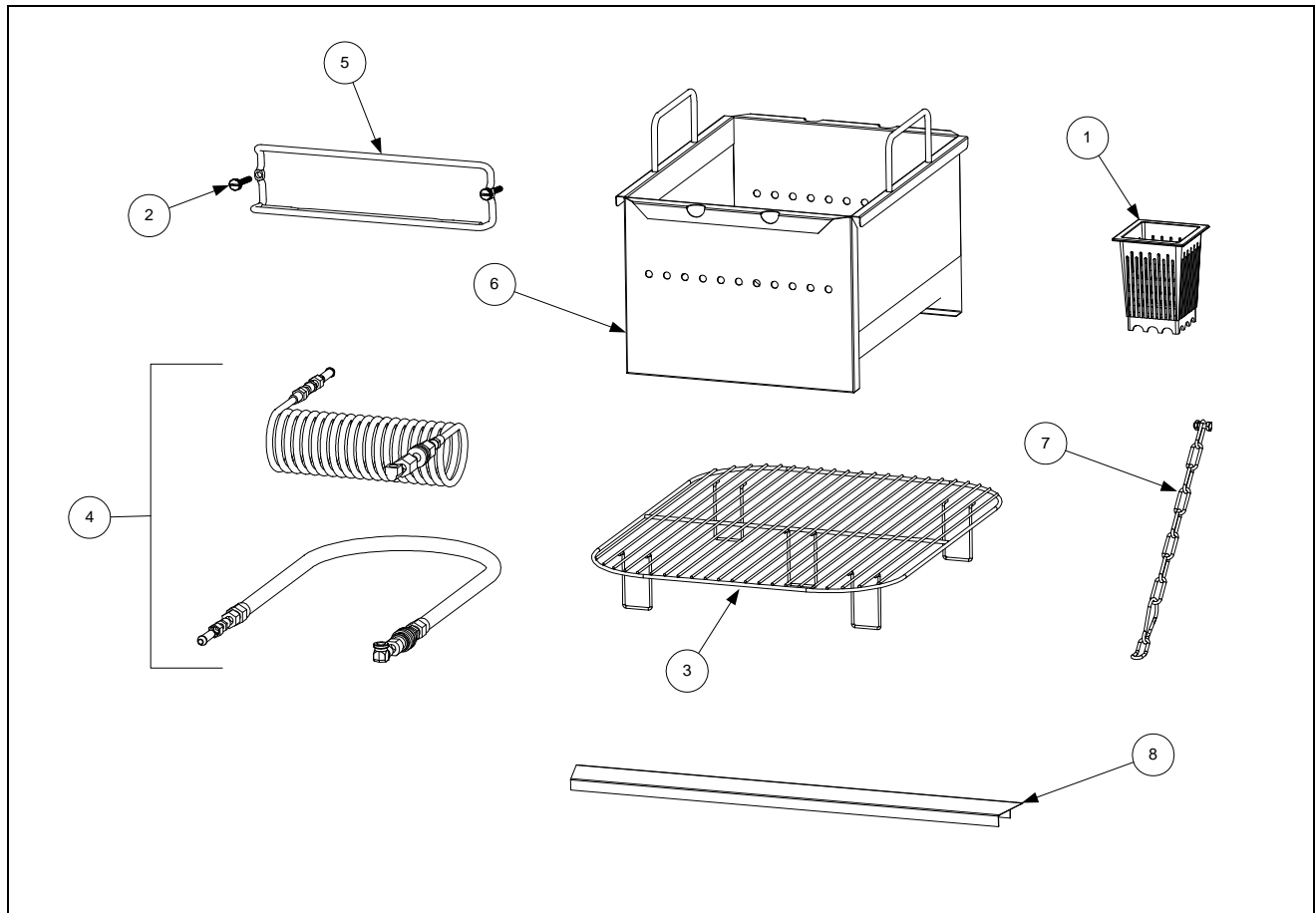

ITEM	PART #	COMPONENT
1	803-0018	Cup, Single Pasta Portion (Beige)
2	810-2229	Hanger, Wire-Form Basket (extruded aluminum P/N 803-0028 no longer available)
3	803-0205	Rack, Support
4	806-5848SP	Kit, Hose (Swirl and Straight w/Fittings)
5	809-0171	Thumbscrew, 1/4-20 x 1 3/8
6	823-1910	Basket, GSMS Bulk
7	826-0900	Kit, Chain Restraint
8	910-7540	Strip, GSMS Top Connecting
*	803-0200	Rack, 12 Portion Cup
*	803-0238	Basket, 5 1/2 x 8 1/2 SS Round Pasta

* Not illustrated.

2.2 Basket Lift Components

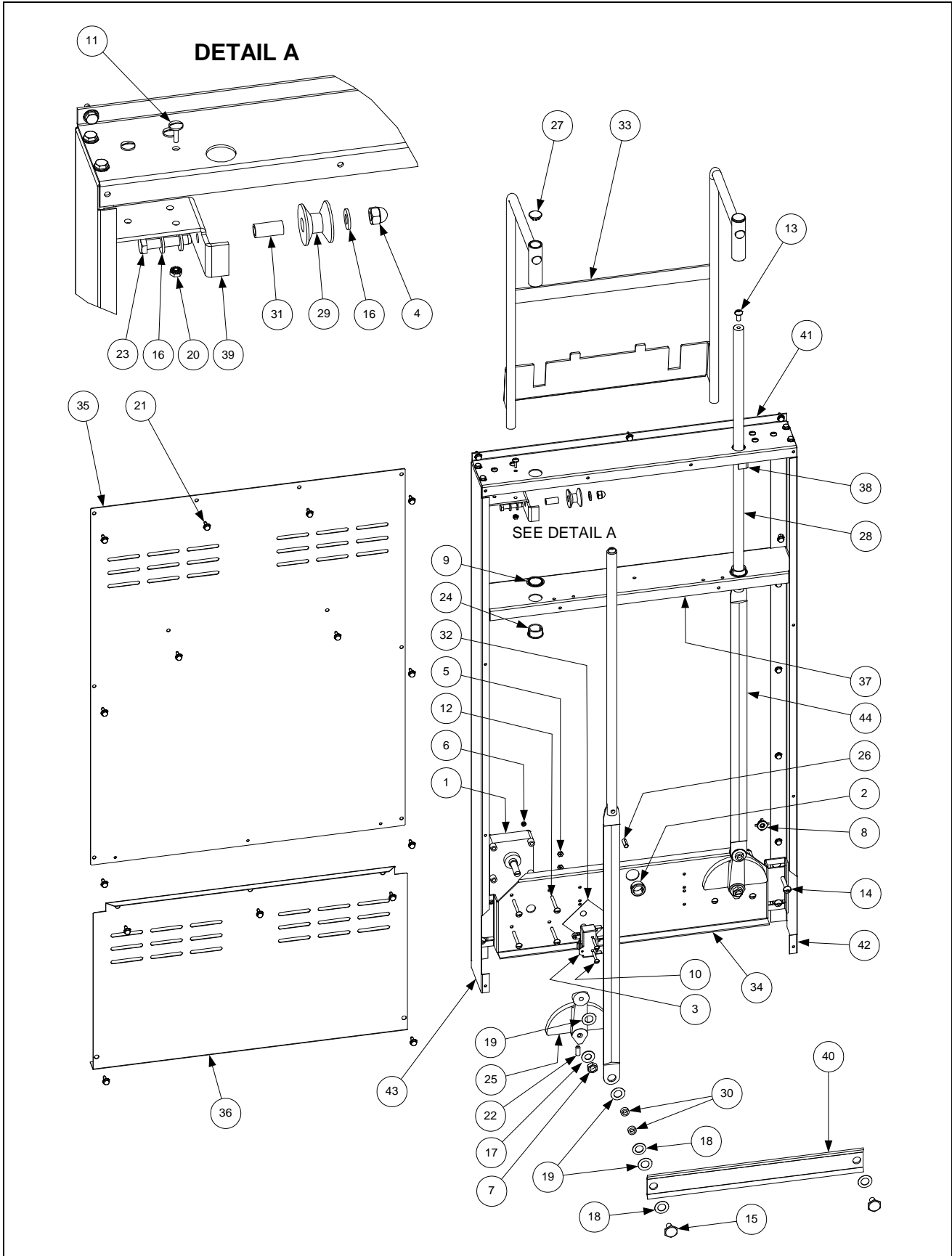

ITEM	PART #	COMPONENT
1		Motor, Basket Lift
	807-0107	120 VAC
	807-0108	240 VAC
2	807-0124	Bushing, Plastic
3	807-0240	Microswitch, BA-2RV22-D6
4	809-0047	Nut, 1/4-20 Hex Head Cap
5	826-1358	Nut, 6-32 Hex Head (Pkg. of 25)
6	809-0050	Nut, 8-32 Hex Head
7	809-0063	Nut, 3/4-inch Jam
8	809-0076	Nut, 1/4-20 Expansion
9	809-0082	Ring, Retaining (secures Item 24 in place)
10	809-0097	Screw, 6-32 x 1-inch Slotted Truss Head
11	826-1363	Screw, 8-32 x 1/2-inch Slotted Truss Head (Pkg. of 25)
12	809-0113	Screw, 8-32 x 1 1/2-inch Slotted Truss Head
13	809-0127	Screw, 1/4-20 x 1/2-inch Slotted Round Head
14	826-1370	Screw, 1/4-20 x 1 1/2-inch Slotted Round Head
15	809-0155	Screw, Leveling
16	809-0190	Washer, 1/4-inch SS Flat
17	809-0196	Washer, 3/8-inch Flat
18	809-0200	Washer, 1/4-inch Flat
19	826-1381	Washer, 1/2-inch Nylatron (Pkg. of 10)
20	809-0247	Nut, 8-32 Hex Head Keps
21	826-1374	Screw, #10 x 1/2-inch Hex Head (Pkg. of 25)
22	809-0480	Setscrew, 1/4-28 x 5/8-inch (secures Item 25 to motor shaft)
23	809-0508	Bolt, 1/4-20 x 1/4-inch SS AT Hex Head
24	813-0035	Bushing, .875 Hole
25	810-0052	Bellcrank (Cam)
26	810-0170	Pin, 1/4-inch x 5/8-inch Spring Dowel
27	810-0172	Button, Plug
28	810-0192	Rod, Basket Lift
29	810-0194	Roller, Basket Lift
30	810-0220	Spacer, .493-inch x .200-inch Tubular
31	810-0374	Spacer, Basket Lift Roller Tubular
32	812-0138	Insulation, Paper
33	823-2007	Arm Assembly, GSMS/GBC Basket Lift
34	900-7416	Mount, Basket Lift Motor
35	900-7418	Back, Upper Basket Lift Enclosure
36	900-7419	Back, Lower Basket Lift Enclosure
37	900-7421	Support, Basket Lift Center
38	901-1927	Bracket, Left Basket Lift Roller
39	902-1927	Bracket, Right Basket Lift Roller
40	910-4525	Bar, Basket Lift Synchronizing
41	910-7420	Top, Basket Lift Enclosure
42	911-7417	Side, Basket Lift Enclosure
43	912-7417	Side, Basket Lift Enclosure
44	920-6076	Link, Basket Lift

NOTE: Order KIT0004SP to add a complete basket lift assembly to a GC unit.

2.3 Cabinetry

2.3.1 GBC/GC

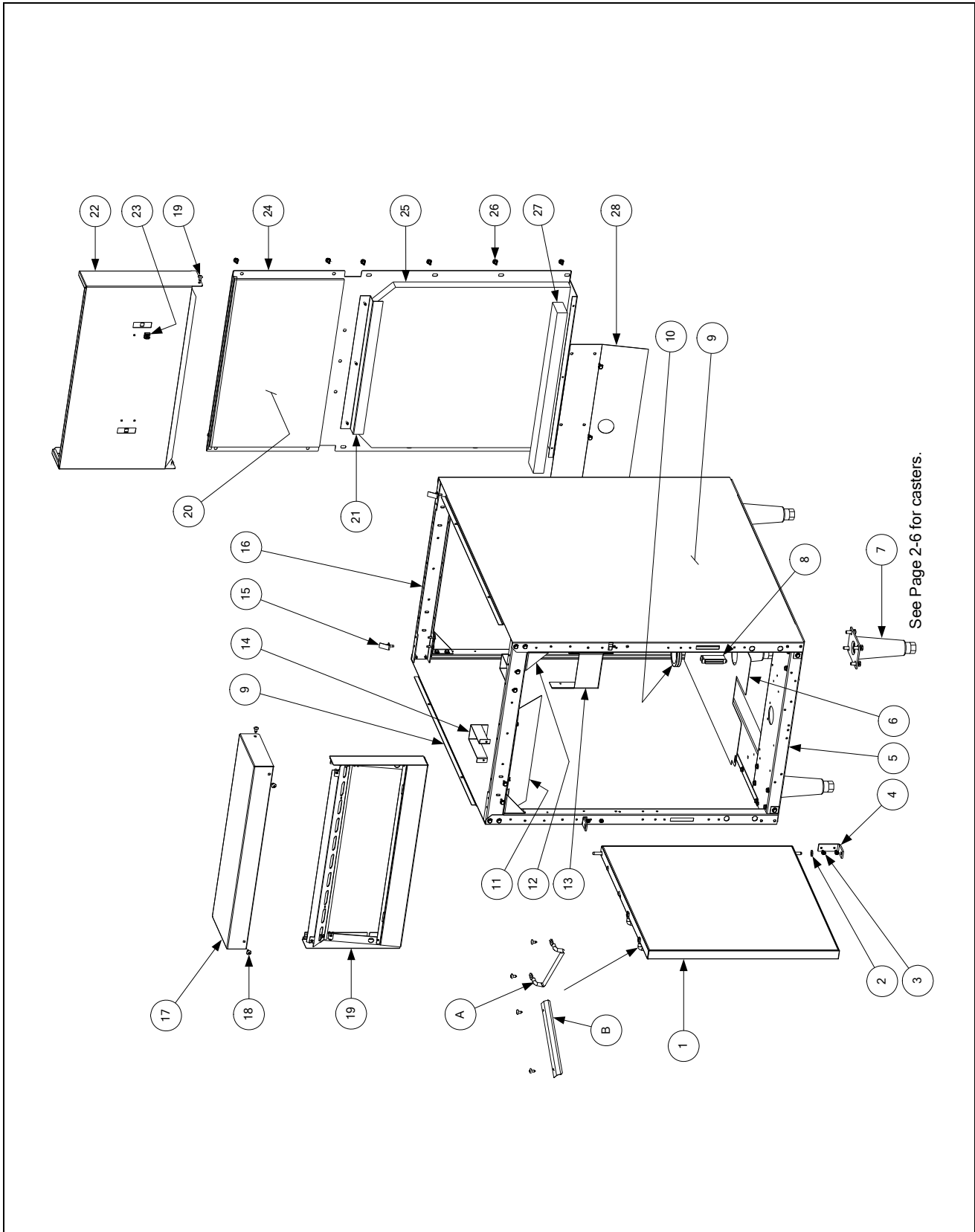

ITEM	PART #	COMPONENT
1	806-3853SP	Door Assembly, 18.66-inch x 19.85-inch (does not include handle)
	806-4487SP	Door Pin Assembly
	826-1343	Spring, Door Hinge (Pkg. of 10)
A	810-1402	Handle, Wireform Door
B	210-9214	Handle, Eurolook Door
2	809-0193	Washer, 1/4-inch Nylon Flat
3	826-1371	Screw, #8 x 1/2-inch Drill Point Hex Head Zinc Plated (Pkg. of 25)
4	810-1508	Hinge, Universal Door
5	806-5522SP	Base Assembly, GBC/GC
	806-5209SP	Leg Pad Assembly
	900-4655	Channel, Front or Rear Base
	900-7528	Channel, Left or Right Base
6	900-7912	Shield, GBC/GC Vapor (See NOTE below)
*	200-5095	Shield, Vapor (for units with manual water fill)
7	826-1115	Leg Assembly w/Mounting Hardware
8	810-1105	Magnet, Door
9		Side, Left or Right Cabinet
	910-7377	Stainless Steel
	900-7377	Enameled Mild Steel
10	816-0091	Grommet, 1/4-inch Drain (See NOTE below)
11	900-4651	Shield, Control Box Water
12	900-1552	Gusset
13	900-1940	Bracket, GBC/GC Control Box Mounting
14	900-1759	Bracket, Pot Hold-Down
15	900-1932	Retainer, Flue Insulation
16	900-4654	Brace, Front or Rear Top
17	824-0434	Topcap, GBC/GC
18	809-0266	Screw, #10 x 1/2-inch Philips Truss Head Zinc Plated
19	806-5260SP	Frame Assembly, Control Panel
20	816-0158	Insulation, 18.25-inch x 10.7-inch x .25-inch Cabinet Back
21	900-4521	Retainer, Cabinet Back Insulation
22	806-6007SP	Flue Cap and Insulation Assembly
	823-2105	Flue Cap
	816-0169	Insulation, 8.12-inch x 18-inch x .25-inch Flue Cap
	910-1181	Retainer, Flue Cap Insulation
	809-0053	Nut, 10-32 Hex
23	826-1351	Nut Retainer, 1/4-20 (Nutsert) (Pkg. of 10)
24	900-7379SP	Back, GBC/GC Cabinet
25	812-1141	Insulation, Cabinet Back
26	826-1374	Screw, #10 x 1/2-inch Hex Head (Pkg. of 25)
27	812-1142	Insulation, Cabinet Back
28	900-4645	Shield, Basket Lift Heat (used on GBC units only)

* Not illustrated.

NOTE: Order Moisture Control Kit [826-1492](#) to retrofit earlier units, which were not equipped with vapor shields. The kit contains items 6 and 10, mounting screws, and installation instructions.

2.3.2 GSMS and GSMS/GBC Batteries

NOTE: GSMS-GBC Battery cabinetry consists of one GSMS cabinet and one GBC cabinet battered together using Fryer Joining Plates (9100404), Cabinet Joining Braces (9100177), and Flue Cap Joining Strips (9103122).

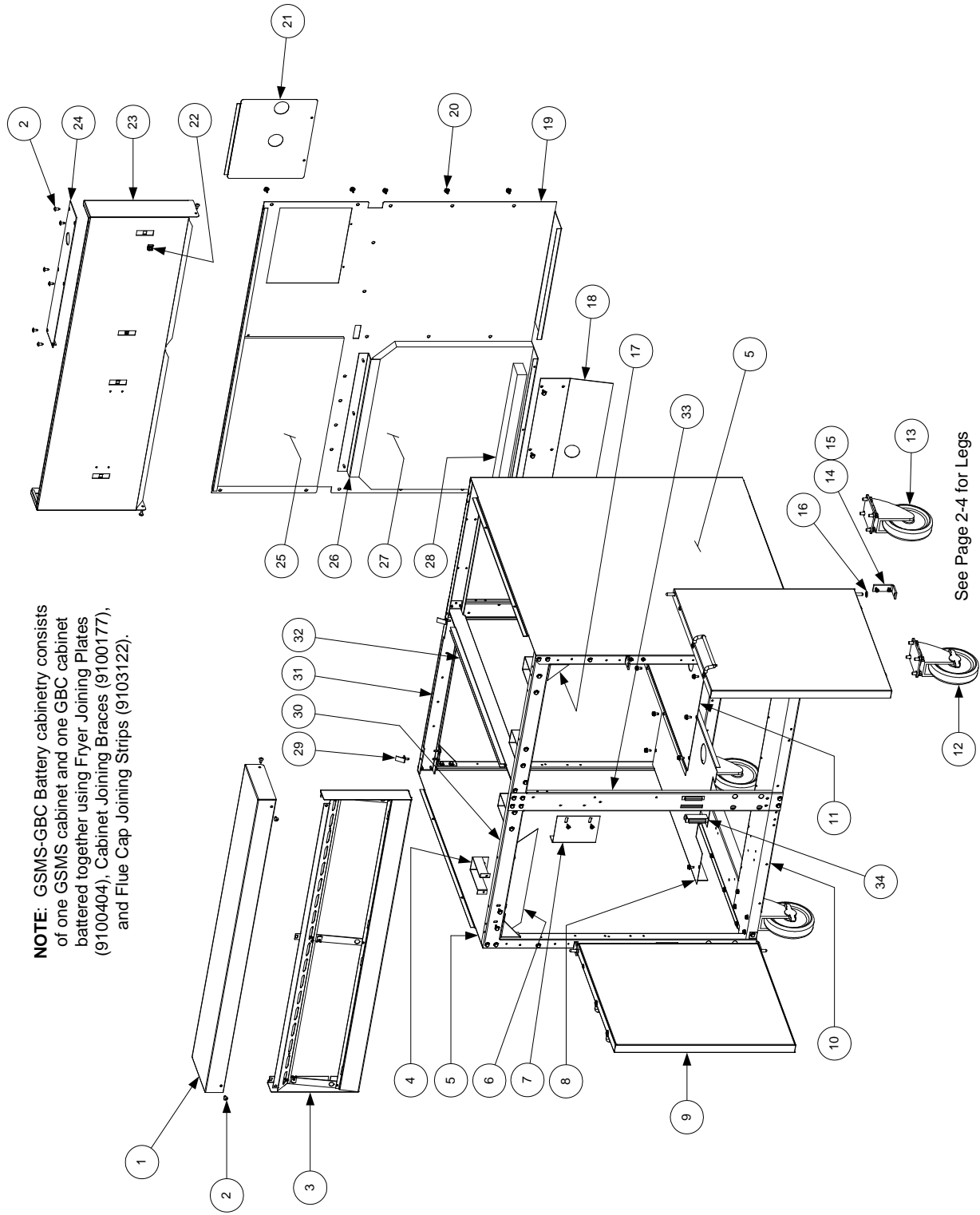

See Page 2-4 for Legs

ITEM	PART #	COMPONENT
1		Topcap
	824-0433	GSMS
	824-0473	GSMS/GBC Battery (for rinse tank on left use 824-0921)
2	809-0266	Screw, #10 x 1/2-inch Philips Truss Head Zinc Plated
3	806-5487SP	Control Panel Assembly, GSMS
4	900-1759	Bracket, Pot Hold-Down
5		Side, Left or Right Cabinet
	910-7377	Stainless Steel
	900-7377	Enameled Mild Steel
6	900-4651	Shield, Control Box Water
7	900-4644	Mount, GSMS Control Box
8	900-8631	Shield, Cookpot-side Vapor
9	806-9744	Door Assembly (does not include handle)
	806-4487SP	Door Pin Assembly
	826-1343	Spring, Door Hinge (Pkg. of 10)
	810-1402	Handle, Wireform Door
10	806-5488SP	Base Assembly, GSMS
	806-5209SP	Leg Pad Assembly
	900-7200SP	Channel, Front or Rear Base
	900-7528	Channel, Left or Right Base
11	900-8632	Shield, Rinse Tank-side Vapor
12	826-1118	Caster w/Brake (includes mounting hardware)
13	826-1117	Caster w/o Brake (includes mounting hardware)
14	810-1508	Hinge, Universal Door
15	826-1371	Screw, #8 x 1/2-inch Drill Point Hex Head Zinc Plated (Pkg. of 25)
16	809-0193	Washer, 1/4-inch Nylon Flat
17	900-1552	Gusset
18	900-4645	Shield, Basket Lift Heat
19	900-7422SP	Back, Cabinet (for rinse tank on left, use 200-2264)
20	826-1374	Screw, #10 x 1/2-inch Hex Head (Pkg. of 25)
21	900-1750	Cover, Faucet Connection Access
22	826-1351	Nut Retainer (Nutsert) (Pkg. of 10)
23	806-6010SP	Flue Cap & Insulation Assembly, GSMS (for rinse tank on left, use 106-
	823-2108	Flue Cap, GSMS (for rinse tank on left, use 823-3451)
	816-0169	Insulation, 8.5-inch x 18-inch GSMS Flue
	910-1181	Retainer, Flue Cap Insulation
	809-0053	Nut, 10-32 Hex
24	910-4646	Mount, Faucet
25	816-0158	Insulation, 18.25-inch x 10.7-inch x .25-inch Cabinet Back
26	900-4521	Retainer, Cabinet Back Insulation
27	816-0170	Insulation, Cabinet Back
28	812-1142	Insulation, Cabinet Back
29	900-1932	Retainer, GSMS Flue Insulation
30	900-7390	Brace, Top Front
31	900-7389SP	Brace, Top Rear
32	900-7391	Divider, Cabinet
33	900-7198	Post, Door
34	810-1105	Magnet, Door (units with rinse tank on left also require bracket 200-2484)

2.4 Combustion System Components

Cookpot shown for reference only.
See Page 2-13 for cookpot components.

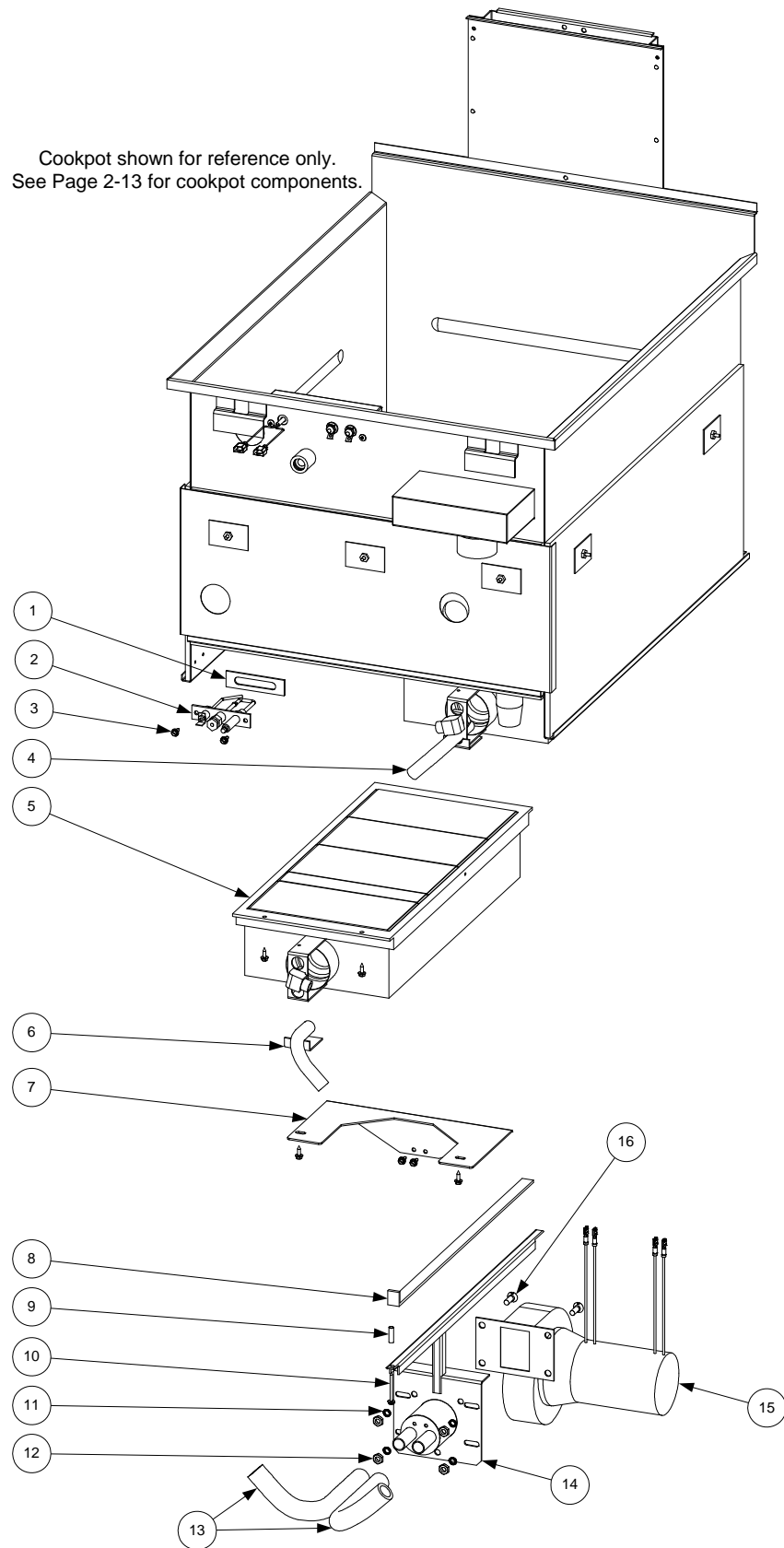

ITEM	PART #	COMPONENT
1	816-0165	Insulation, GSMS/GBC/GC Ignitor
2		Ignitor
	810-0521	Natural Gas
	810-0608	Propane Gas
	810-0923	Manufactured Gas
3	826-1371	Screw, #8 x ½-inch Drill Point Hex Head Zinc Plated (Pkg. of 25)
4	823-2685	Bracket and Tube Assembly, Right Air Hose
5		Burner Assembly (See NOTE at bottom of Page 2-13 also.)
	806-5563SP	Natural Gas w/3.26mm Orifice 810-0916
	806-5499SP	Natural Gas w/3.05mm Orifice 810-0465
	806-5564SP	Propane Gas w/2.00mm Orifice 810-0917
	806-5583SP	Manufactured Gas w/4.92mm Orifice 810-0924
	810-1382	Natural or Propane Gas Burner w/o Orifice
	810-1385	Manufactured Gas Burner w/o Orifice
6	823-2526	Bracket and Tube Assembly, Left Air Hose
7	900-5525	Bracket, Blower Support
8	816-0055	Insulation, Blower Mount
9	810-0507	Spacer, .23-inch x .75-inch
10	809-0441	Screw, #7 x 1½-inch Hex Washer Head Nickel Plated
11	809-0191	Washer, ¼-inch Lock
12	826-1362	Nut, ¼-20 Hex Head (Pkg. of 10)
13	816-0278	Hose, ⅝-inch Air
14	823-2528	Mount, Blower
15		Motor, Blower
	807-1564	120VAC/60 Hz (See NOTE below)
	807-1712	230VAC 50/60 Hz (See NOTE below)
16	809-0433	Screw, ¼-20 x ¾-inch Slotted Flat Head

NOTE: For complete motor and mount assemblies, order [806-5259SP](#) (120VAC/60 Hz) or [806-5574SP](#) (230VAC 50/60 Hz). These assemblies include items 11, 12, 14, 15, and 16.

2.5 Control Box and Related Components

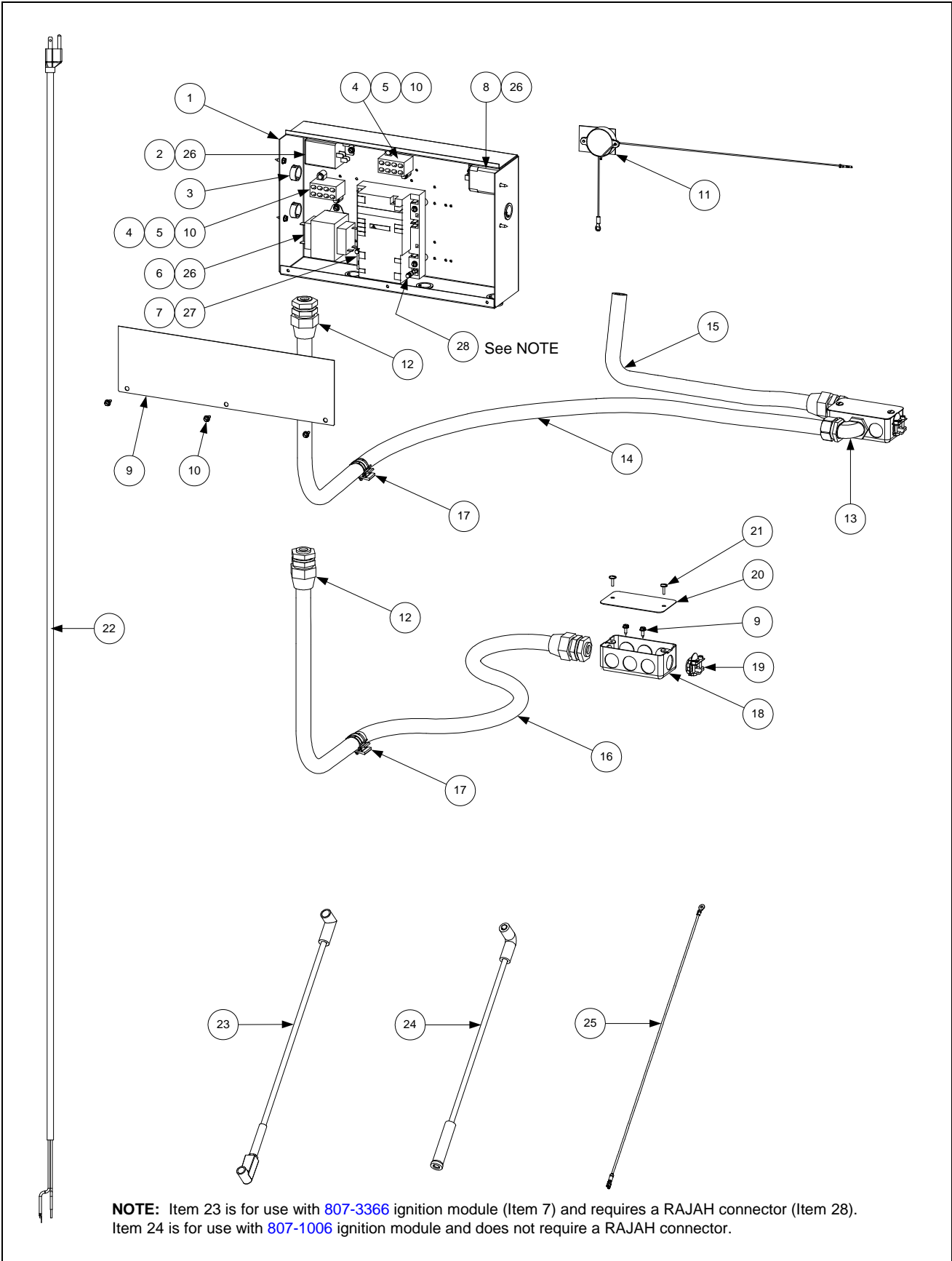

ITEM	PART #	COMPONENT
1	900-7532	Box, Control
2	807-1396	Relay, 24VDC SPDT (Basket Lift Relay – GSMS and GBC units only)
3	810-0045	Bushing, .875 Diameter Hole
4	807-0067	Block, 8-Pin Terminal
5	807-0255	Strip, Terminal
6		Transformer
	807-0800	120VAC/24VAC, 50/60 Hz, 50VA
	807-0680	208-240VAC/24VAC, 50/60 Hz, 43VA
7	807-3366	Module, Honeywell Dual-Spark FV Ignition (See NOTE below.)
8	807-0670	Relay, 24V DPDT (Heat Relay – all units)
9	900-1924	Guard, Finger
10	826-1371	Screw, #8 x ½-inch Drill Point Hex Head Zinc Plated (Pkg. of 25)
11	807-1713	Sound Device (Alarm)
12	807-1292	Fitting, Plastic Conduit
13	807-1319	Connector, 90° #5252
14†	812-1193	Conduit, ½-inch x 53-inch Flexible Plastic (cut to length from 811-0808)
15†	812-1187	Conduit, ½-inch x 18-inch Flexible Plastic (cut to length from 811-0808)
16†	812-1192	Conduit, ½-inch x 47-inch Flexible Plastic (cut to length from 811-0808)
17	809-0290	Clamp, Cable
18	807-0170	Box, Electrical Handy
19	807-1612	Clamp, ⅜-inch Twin-Screw Connector
20	900-8016	Cover, Electrical Handy Box
21	826-1363	Screw, 8-32 x ½-inch Slotted Truss Head Nickel Plated (Pkg. of 25)
22		Cordset
	807-0154	120VAC (illustrated)
	807-1685	208-240VAC (not illustrated)
23	106-0676SP	Cable, Ignition (used with Item 7 – also requires Item 28)
24	807-1709	Cable, Ignition (used with 807-1006 Ignition Modules)
25	806-5316SP	Wire Assembly, 20-inch High Temperature (Flame Sensor Wire)
26	809-0362	Screw, #8 x 1¼-inch Drill Point Hex Washer Head Zinc Plated
27	809-0441	Screw, #7 x 1½-inch Hex Washer Head Nickel Plated
28	807-3484	Connector, RAJAH (two required for each 807-3366 Ignition Module)
††	806-5632	Wiring Assembly, 120VAC GBC
*	806-8307SP	Wiring Assembly, GSMS/GBC/GC (Controller Harness)

* Not illustrated.

† Number for reference only. Order appropriate length of 811-0808.

†† Not illustrated. Includes conduit, handy box, and fittings.

NOTE: Control box assemblies on units manufactured before October 2000 were built with two single-spark ignition modules (P/N 807-1006). If an 807-1006 module fails, the control box may be retrofitted with one dual-spark ignition module (Item 7 – P/N 807-3366) and two RAJAH connectors (Item 28 – P/N 807-3484). If this option is chosen, the earlier style ignition cables (Item 24 – P/N 807-1709) must also be replaced with the new ignition cables (Item 23 – P/N 106-0676SP).

2.6 Controllers and Control Panel Components

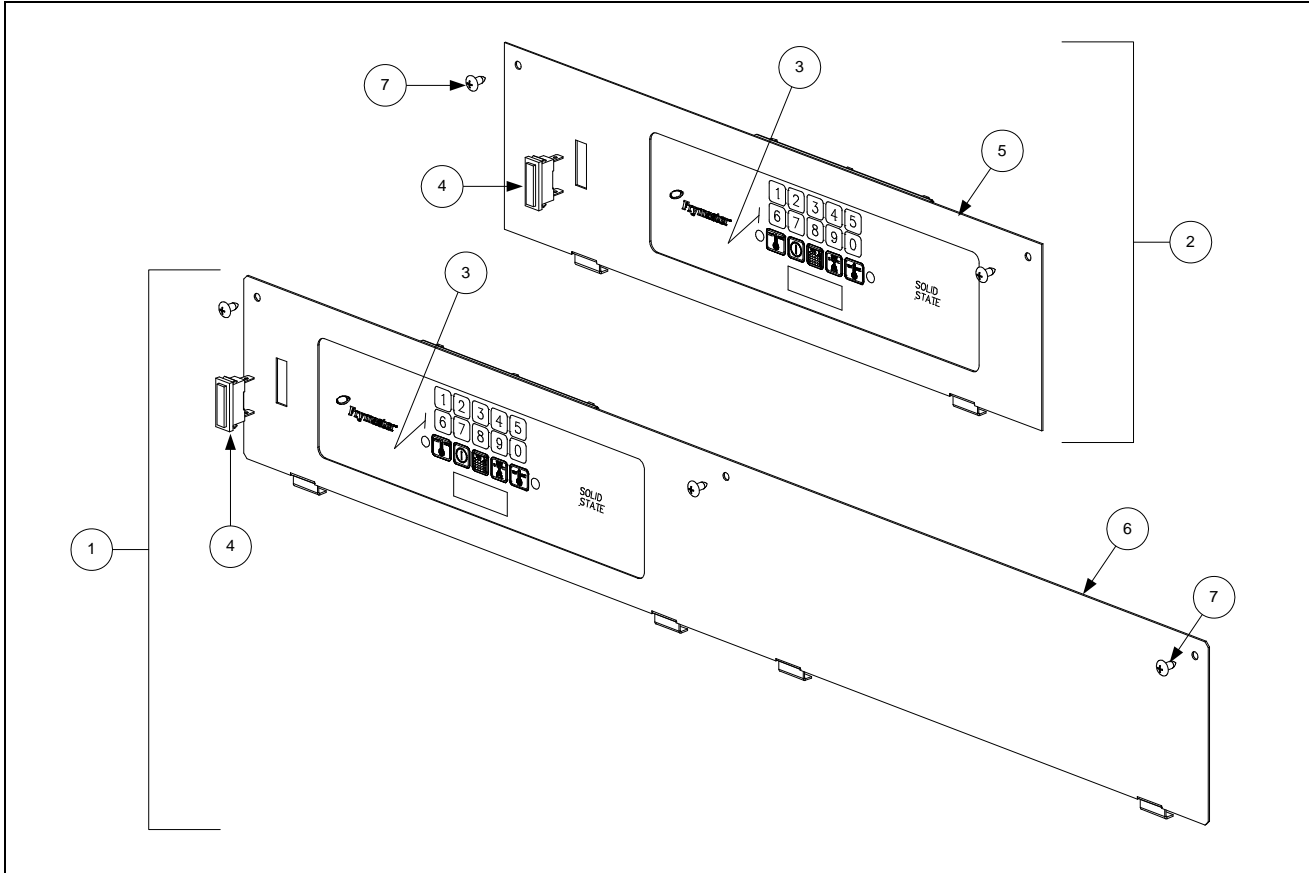

ITEM	PART #	COMPONENT
1		Control Panel and Controller Assembly, GSMS (does not include 4 & 7)
	106-0376	Full Featured
	106-0379	w/o Autoskim
	106-0380	w/o Autofill or Autoskim
2		Control Panel and Controller Assembly, GBC/GC (does not include 4 & 7)
	106-0377	Full Featured
	106-0381	w/o Autoskim
	106-0382	w/o Autofill or Autoskim
3		Controller, SMS III
	106-0376E	Full Featured
	106-0379E	w/o Autoskim
	106-0380E	w/o Autofill or Autoskim
4	807-1704	Lamp, 24VAC Vertical Trouble
5	823-2012	Panel, GBC/GC Control
6	823-1993	Panel, GSMS Control (for rinse tank on left, use 823-3331)
7	809-0266	Screw, #10 x 1/2-inch Philips Truss Head Zinc Plated

NOTE: See last item on Page 2-11 for Controller Harness.

2.7 Cookpot, Rinse Tank, and Associated Components

2.7.1 Cookpot and Rinse Tank Components (Other than Cookpot Insulation)

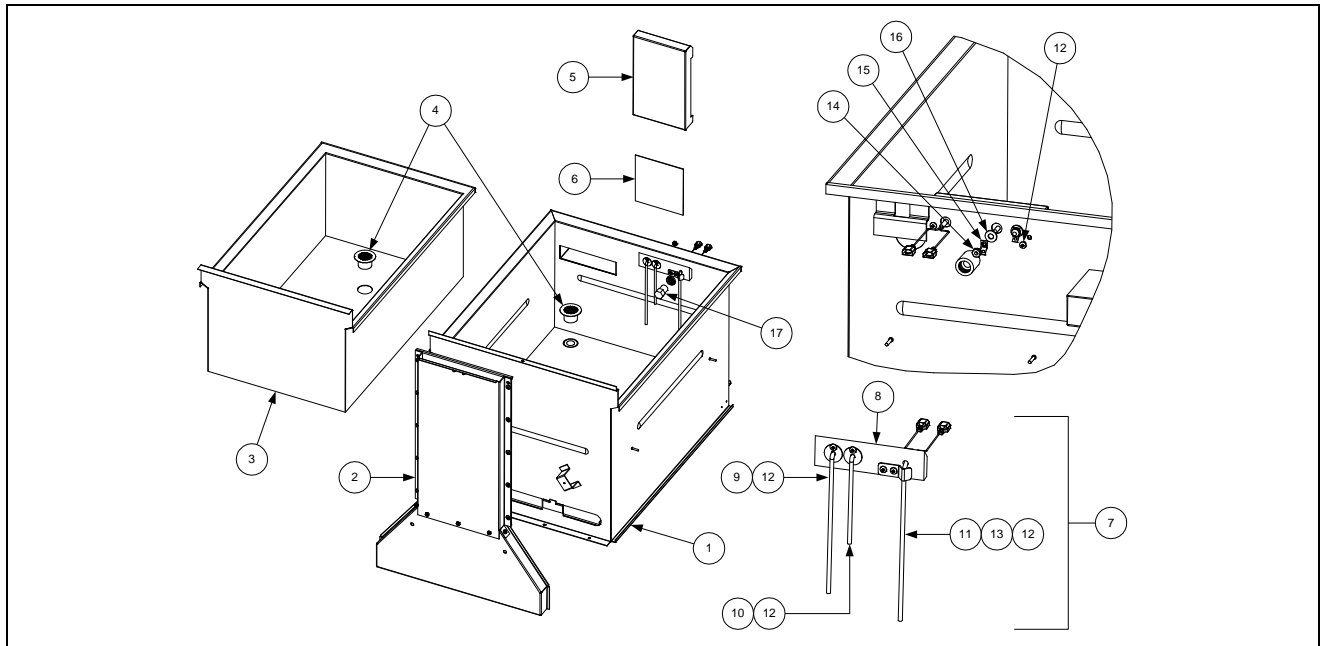

ITEM	PART #	COMPONENT
1	823-4090SP	Cookpot, GSMS (Use 823-4227SP for units with manual fill. See NOTE below.)
2	806-5497SP	Flue Assembly, GSMS (See NOTE below.)
3	823-1994SP	Tank, GSMS Rinse
*	106-2797SP	Complete Burner, Frypot, Flue Auto Fill assembly, NAT
*	106-2798SP	Complete Burner, Frypot, Flue Auto Fill assembly, PRO
*	106-3055SP	Complete Burner, Frypot, Flue Manual Fill assembly, NAT
*	106-3056SP	Complete Burner, Frypot, Flue Manual Fill assembly, PRO
4	823-2022	Strainer Assembly
5	823-2791	Cover, Probe Block (angled top) (for flat-topped block, use 823-1942)
6	816-0160	Insulator, 5.25-inch x 5.00 Probe Cover
7		Probe Block Assembly, Complete
	806-9365SP	Angled top, for use on units without Autofill option.
	806-9366SP	Angled top, for use on units with Autofill option.
	106-3084SP	Angled top, for use on units with manual fill.
	826-1082	Flat top w/pins, for use on units without Autofill option.
	826-1081	Flat top w/pins, for use on units with Autofill option.
*	810-1212	Replacement Pin, for use w/flat-topped probe blocks.
8	810-1697	Block, Probe (angled top) (for flat-topped block, use 810-0821)
9	823-1920	Sensor, Low Water Level (806-9365SP and 826-1082 use two each)
10	823-1921	Sensor, Normal Water Level (used in 806-9366SP and 826-1081)
11	806-4764	Probe Assembly, Temperature
12	809-0357	Screw, #6 x 3/8-inch Philips Truss Head Nickel Plated
13	910-1804	Bracket, Probe Retainer
14	826-1376	Nut, 10-32 Keps Hex Head (Pkg. of 10)
15	826-1337	Tab, Faston .25-inch (Pkg. of 5)
16	809-0193	Washer, 1/4-inch Nylon Flat
17	810-0976	Nozzle, Water Inlet

* Not illustrated.

2.7.2 Cookpot Insulation

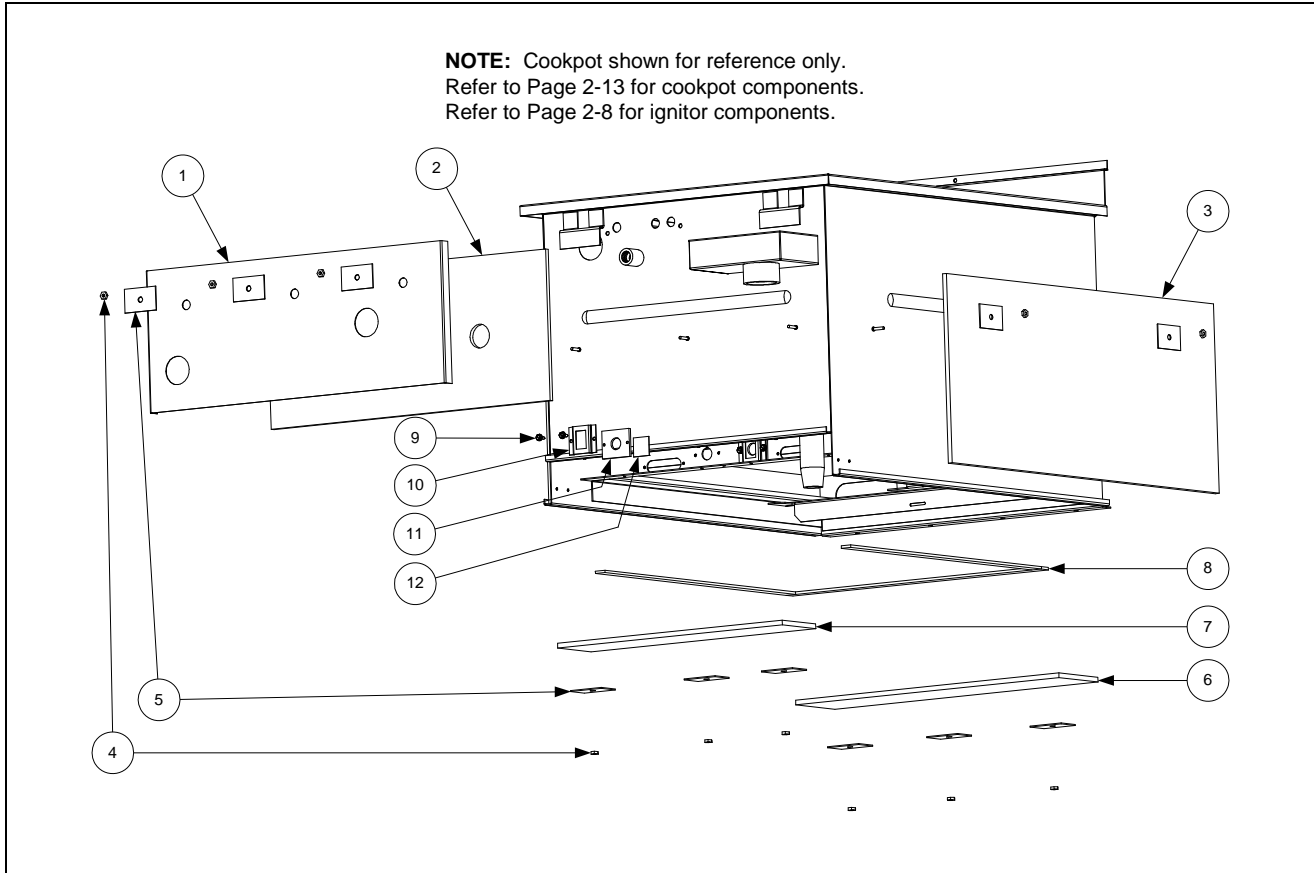

ITEM	PART #	COMPONENT
1	900-4563	Retainer, Cookpot Front Insulation (19.7-inches x 7.5-inches)
2	816-0152	Insulation, Cookpot Front (19.5-inches x 7.5-inches x .25-inches)
3	816-0153	Insulation, Cookpot Side (10-inches x 24-inches x .25-inches)
4	809-0053	Nut, 10-32 Hex
5	900-1762	Retainer, Insulation
6	816-0145	Insulation, Front Bottom (3.0-inches x 14.5-inches x .25-inches)
7	816-0166	Insulation, Rear Bottom (3.5-inches x 17.0-inches x .25-inches)
8	812-0357	Insulation, HE Burner
9	826-1371	Screw, #8 x 1/2-inch Drill Point Hex Head Zinc Plated (Pkg. of 25)
10	900-1031	Retainer, Sight Glass
11	816-0053	Insulation, Sight Glass
12	814-0048SP	Glass, Sight

2.8 Drain Components

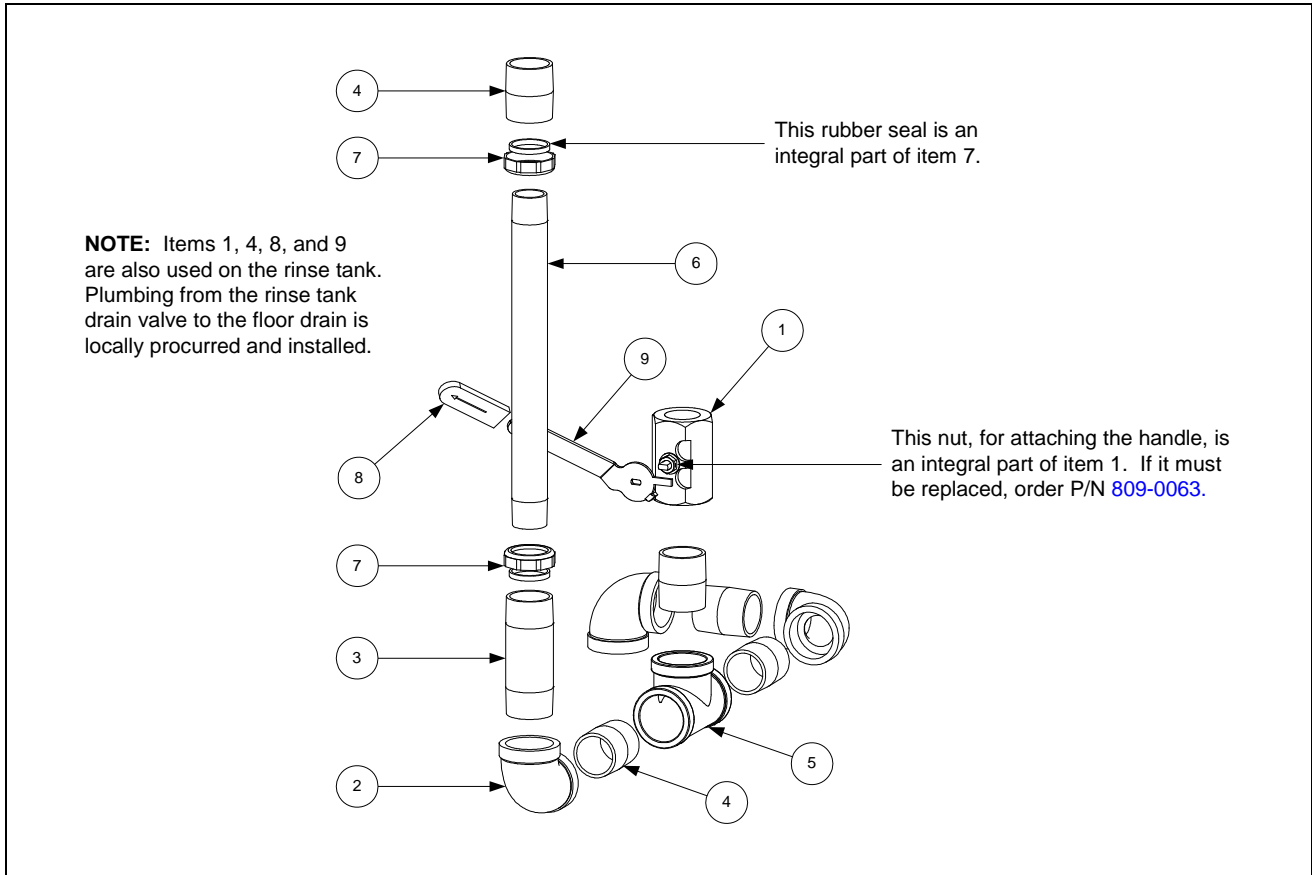

ITEM	PART #	COMPONENT
1	810-1825	Valve, 1¼-inch x 1¼-inch SS Drain
2	813-0070	Elbow, 1¼-inch NPT BM 90°
3	813-0146	Nipple, 1¼-inch NPT x 4¼-inch BM
4	813-0391	Nipple, 1¼-inch NPT x Close BM
5	813-0394	Tee, 1¼-inch NPT BM
6	813-0451	Nipple, 1¼-inch NPT x 12-inch Chromed Brass
7	813-0453	Nut, 1¼-inch NPT Chromed SS Slip
8	814-0047	Sleeve, Valve Handle (red, w/logo)
9	910-9527	Handle, Drain Valve

2.9 Gas Supply System Components

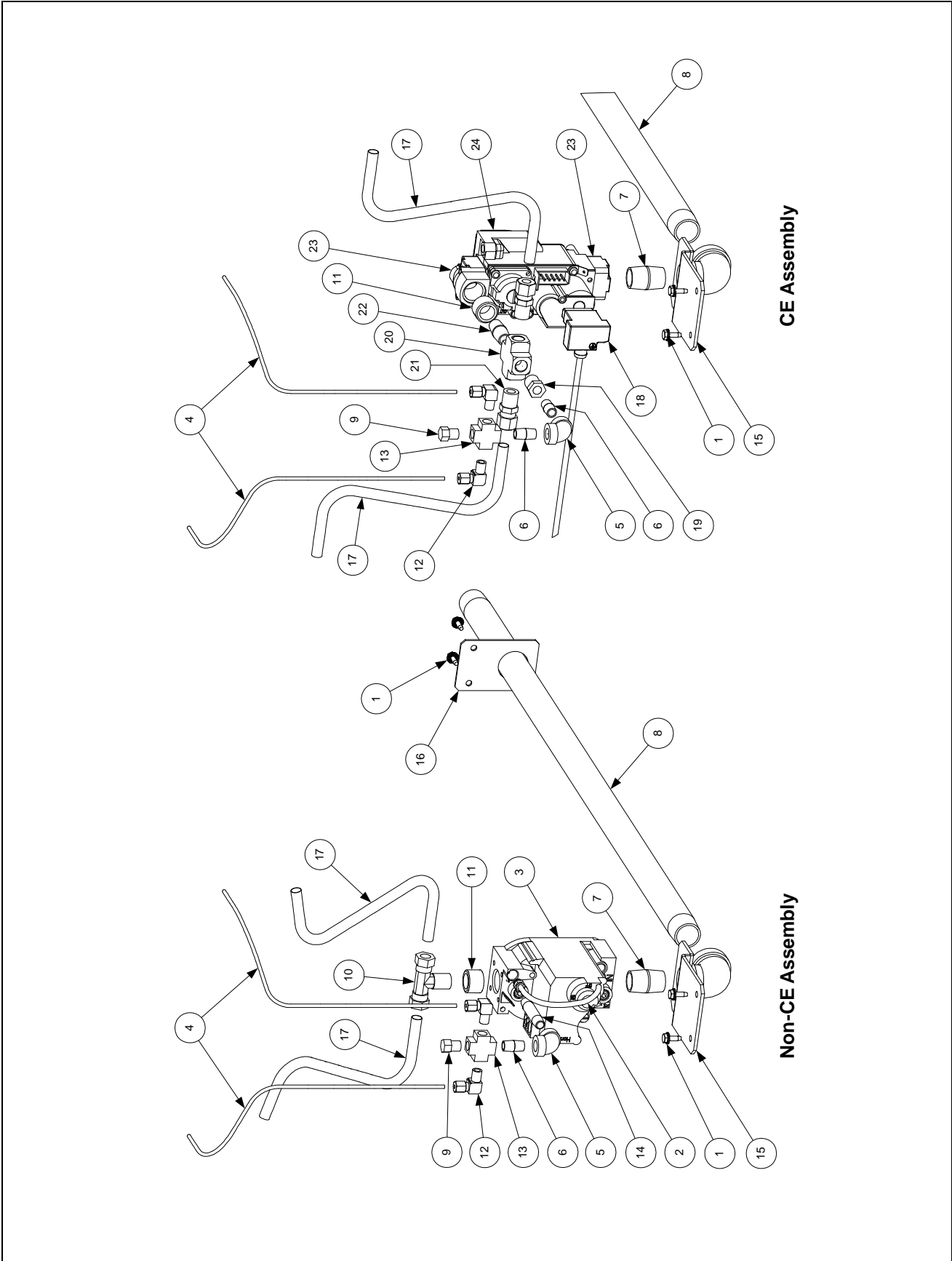

ITEM	PART #	COMPONENT
1	826-1374	Screw, #10 x ½-inch Hex Head (Pkg. of 25)
2	810-0691	Tube, Vent
3		Valve, Honeywell Gas (Non-CE)
	826-1122	Natural or Manufactured Gas (See NOTE 2.)
	826-1123	Propane Gas
4	811-0800	Tube, 12.5-inch Enrichment (See NOTE 1.)
5	813-0004	Elbow, ⅛-inch NPT 90° BM
6	813-0016	Nipple, ⅛-inch NPT x Close BM
7	813-0022	Nipple, ½-inch NPT x Close BM
8		Nipple, ¾-inch NPT BM
	813-0137	28.5-inch (used on GSMS units)
	813-0257	24.5-inch (used on GBC/GC units)
9	813-0154	Plug, ⅛-inch Hex Head Pipe
10	813-0301	Tee, ¼-inch NPT Male x ⅜-inch Tube Brass (See NOTE 2.)
11	813-0304	Bushing, ½-inch to ¼-inch Flush BM (See NOTE 2.)
12	813-0354	Elbow, 90° ⅛-inch NPT x ⅛-inch Tube Brass
13	813-0378	Fitting, ⅛-inch NPT Female Cross
14	813-0405	Nipple, ⅛-inch NPT x 2.00-inch BM
15	823-2004	Mount, Front Gas Line
16	900-4642	Hanger, Rear Gas Line
17	900-4643	Tube, ⅜-inch Aluminum Gas (See NOTE 1 and NOTE 2.)
18	806-9678SP	Plug, CE Honeywell Gas Valve
19	810-1006	Bushing, ¼-inch NPT to ⅛-inch NPT Brass
20	813-0567	Fitting, ¼-inch NPT Female Cross
21	810-1025	Connector, ¼-inch NPT male x ⅜-inch Tube Brass
22	813-0077	Nipple, ¼-inch NPT x Close Galvanized
23*	810-1041	Kit, CE Valve Accessory
24	810-1715	Valve, Honeywell CE Gas (Natural or Propane)

* Contains straight and elbow flanges, o-rings, and screws for mounting flanges to valve.

NOTE 1: Item 4 is delivered straight and must be formed by the installer to fit the unit. Item 17 is delivered formed, but may require further forming by the installer to fit the unit.

NOTE 2: In Manufactured Gas (MFG) units, item 10 is replaced by P/N 810-0926, item 11 is not used, and item 17 is replaced by P/N 900-1945.

2.10 Water Supply System Components

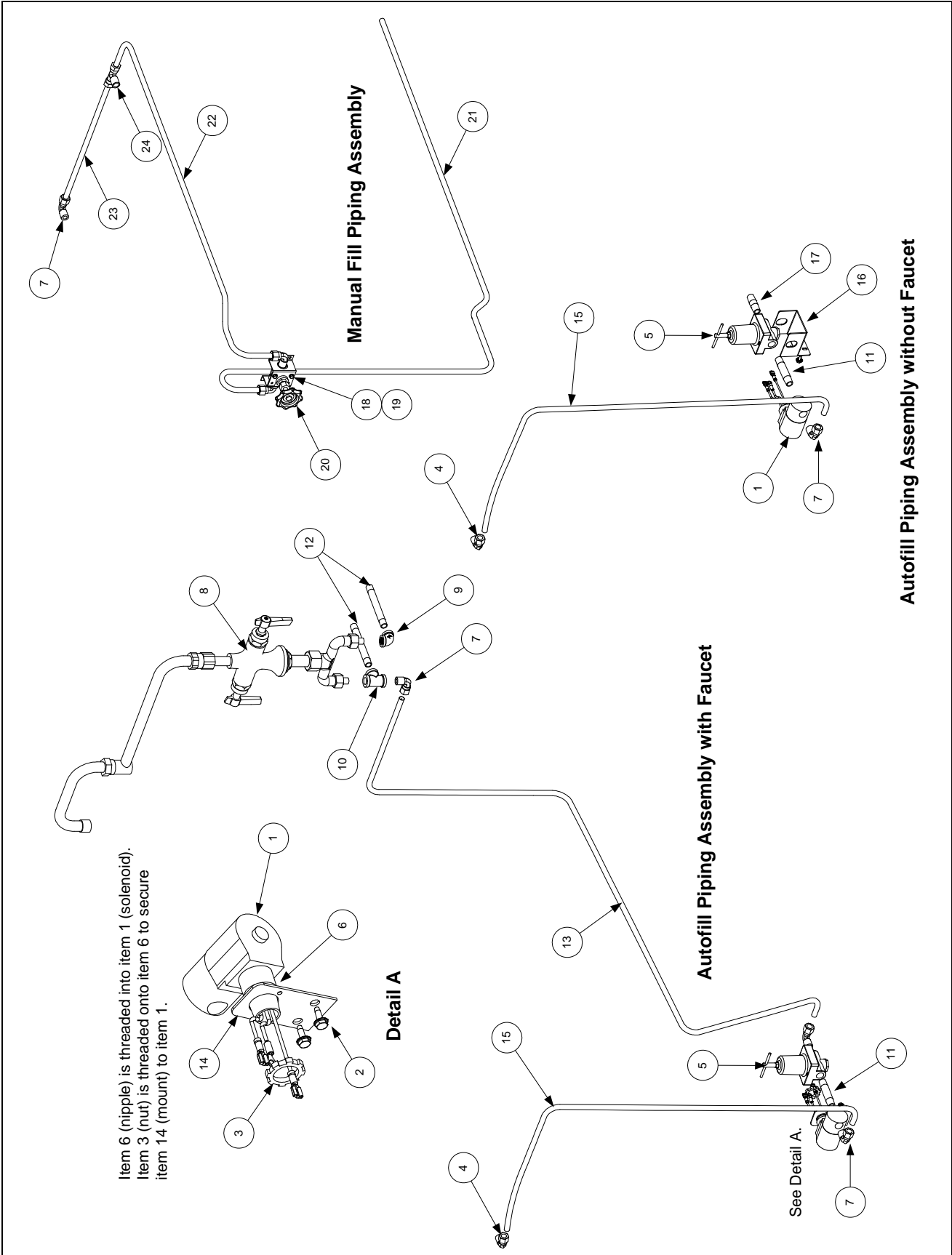

ITEM	PART #	COMPONENT
1	806-5565	Valve Assembly, Solenoid
2	826-1374	Screw, #10 x 1/2-inch Hex Head (Pkg. of 25)
3	809-0454	Nut, 1/2-inch Conduit
4	810-0907	Elbow, 3/8-inch NPT Compression
5	810-1208	Valve, Pressure Regulator
6	813-0022	Nipple, 1/2-inch NPT x Close BM
7	813-0302	Elbow, 1/4-inch NPT x 3/8-inch Tube Compression
8	813-0412	Faucet, Double-Jointed Pantry
9	813-0448	Elbow, 1/4-inch NPT Brass
10	813-0449	Tee, 1/4-inch NPT Brass
11	813-0472	Nipple, 1/4-inch NPT x 2.5-inch Brass
12	813-0473	Nipple, 1/4-inch NPT x 4.0-inch Brass
13	900-1898	Tubing, Pressure Regulator to Faucet
14	900-1905	Mount, Solenoid Valve Assembly
15	910-2513	Tubing, Solenoid to Cookpot
16	900-2916	Bracket, Pressure Regulator
17	813-0471	Nipple, 1/4-inch NPT x 1.5-inch Brass (See NOTE below.)
18	200-5094	Bracket, Water Valve
19	809-0359	Screw, #8 X 1/4-inch Slotted Hex Washer Head
20	810-2641	Valve, 3/8-inch Water
21	810-2648	Tube, Water Inlet
22	810-2649	Tube, Water Outlet
23	810-2650	Tube, Cookpot Water
24	813-0301	Tee, 1/4-inch NPT Male X 3/8-inch Tube Brass

NOTE: In Autofill units without a faucet, water supply piping to item 17 appropriate for the installation is provided by the purchaser or installer.

APPENDIX A

NOTES AND PARTS UNIQUE TO GSW/GWB VARIANTS

A relatively small number of GSW/GWB variants have been manufactured. These two variants are very similar to the GC cooker. The principal differences are the use of a thermostat control rather than a computer and button-type water level sensors in the cookpot as opposed to the rod-type used in the GC cooker. There are also minor differences in the water supply systems. Most of these units have been manufactured as single units. The few double units constructed are basically two single units battered together. Neither variant has a rinse tank.

The illustrations that follow identify assemblies and components that are used in the GSW/GWB units but not in the GSMS, GBC, or GC cookers. If a part is **NOT** listed in the pages that follow, it is used in the other units and illustrated Chapter 2.

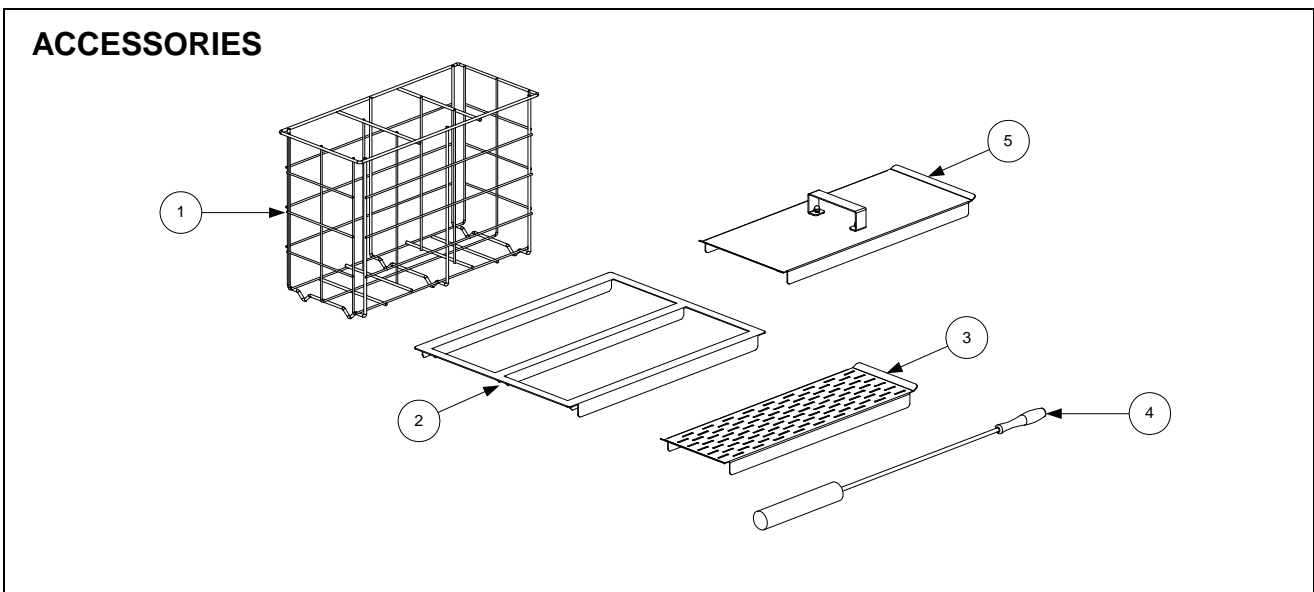

Item	Part #	Component
1	803-0226	Basket, Sauce
2	910-2766	Insert, Pan Holder
3	910-2545	Strainer
4	803-0234	Brush, Probe Cleaning
5	806-7569	Cover, Sauce Basket
*	803-0218	Rack, Nine Cup

* Not illustrated.

CONTROL COMPONENTS

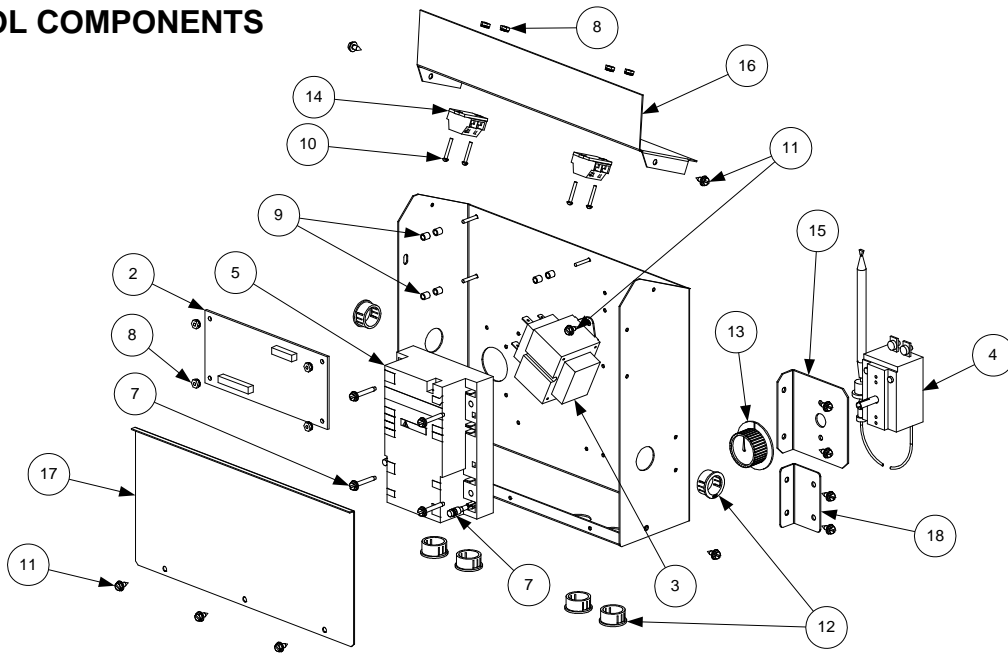

Item	Part #	Component
1	806-8667	GSW/GWB Control Box
2	806-9592	Interface Board (Water Board)
3	807-0800	Transformer, 120V/24VAC 50/60 Hz, 50 VA
4	807-2272	Thermostat, Operating
5	807-3366	Module, Dual Spark Honeywell Ignition (See NOTE below.)
6	807-3484	Connector, Rajah
7	809-0164	Screw, #8 X 1-inch Slotted Hex Washer Head
8	826-1366	Nut, 4-40 Keps Hex (package of 25)
9	809-0349	Spacer, 4 mm X 6 mm Aluminum
10	826-1359	Screw, 4-40 X ¾-inch Round Slot Head (package of 25)
11	809-0360	Screw, #8 X ⅜-inch Slotted Hex Washer Head
12	810-0045	Bushing, .875-inch Diameter (fits 11/16-inch hole)
13	810-0387	Knob, Thermostat Control
14	810-1164	Terminal Block, 1-Piece Screwless
15	900-2484	Mount, Operating Thermostat
16	900-2769	Top Cover, Control Box
17	900-2919	Front Cover, Control Box
18	900-2958	Bracket, Control Box Mounting
*	807-2273	Switch, SPDT (Skim Feature and Faucet ON/OFF Switch)
*	807-0495	Light, Split, 24V Red and White
*	807-2479	Switch, SPDT ON/OFF Rocker (Power Switch)
*	910-2454	Panel, Control

* Not illustrated.

NOTE: Units manufactured prior to October 2000 were equipped with two [807-1006](#) ignition modules. Use a single [807-3366](#) module to replace them. Refer to wiring diagram 805-0521 on Page A-6 for new wiring connections. The new modules also require the use of a new ignition cable (P/N 106-0676).

SERVICE COOKPOT

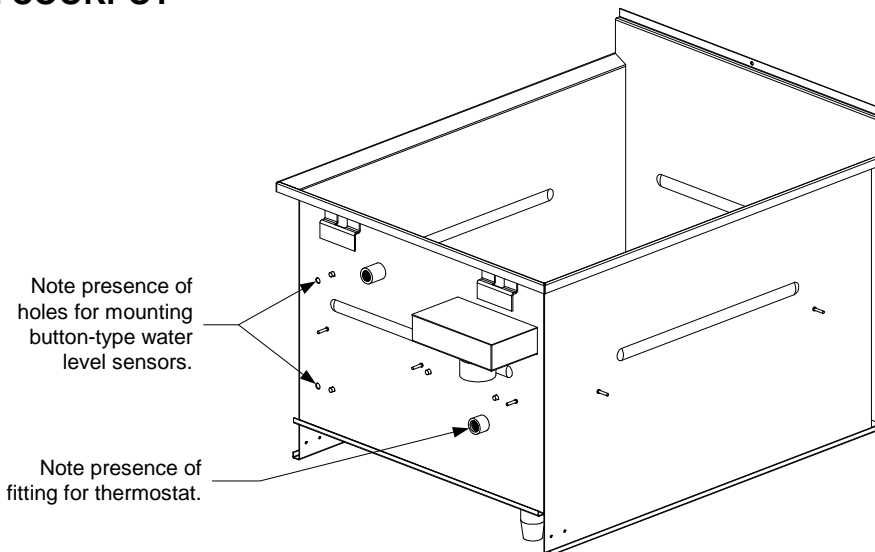

Note presence of holes for mounting button-type water level sensors.

Note presence of fitting for thermostat.

Order P/N 823-0491SP for the bare service cookpot (cookpot without insulation).

Order P/N [806-5497SP](#) for the flue assembly only.

Order [106-2797SP](#) (Natural Gas) or [106-2798SP](#) (Propane) for the cookpot assembly with insulation.

Order 106-2804SP (Natural Gas) or 106-2805SP (Propane) for the complete cookpot assembly (including the cookpot, flue assembly, burners, blower, insulation, and associated hardware).

Order P/N [806-7552SP](#) for button-type water level sensors.

For combustion system components, refer to Page 2-8.

For insulation and related components, refer to Page 2-14.

For drain system components, refer to Page 2-15.

For gas supply system components, refer to Page 2-16.

WATER SUPPLY COMPONENTS

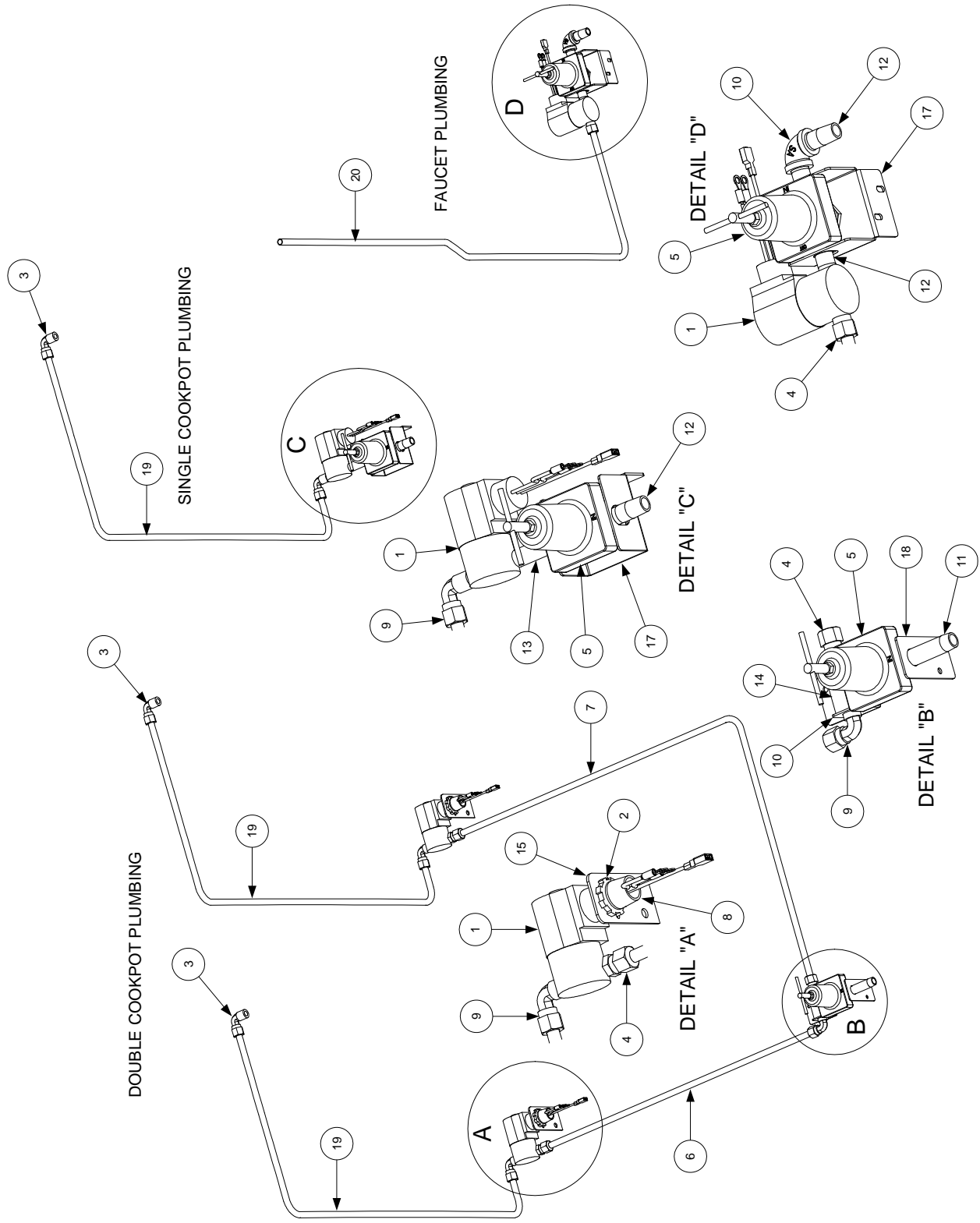

Item	Part #	Component
1	806-7551	Valve Assembly, GSMS Solenoid
2	809-0454	Nut, 1/2-inch Conduit
3	810-0907	Elbow, 3/8-inch NPT Compression
4	810-1025	Fitting, 1/4-inch Straight Compression
5	810-1208	Valve, Water Pressure Regulator
6	812-1292	Tubing, Straight 21.75-inch Regulator to Solenoid Valve
7	812-1293	Tubing, 90° Formed 39.22-inch Regulator to Solenoid Valve
8	813-0022	Nipple, 1/2-inch Close BM NPT
9	813-0302	Elbow, 1/4-inch NPT X 3/8-inch Tube
10	813-0448	Elbow, 1/4-inch Brass NPT
11	813-0450	Nipple, 1/4-inch NPT X 2.0-inch
12	813-0471	Nipple, 1/4-inch NPT X 1.50-inch
13	813-0472	Nipple, 1/4-inch NPT X 2.50-inch
14	813-0495	Tee, 1/4-inch Brass NPT Male Branch
15	900-1905	Mount, GSMS Solenoid Valve
16	900-2915	Bracket, Pressure Regulator
17	900-2916	Bracket, Pressure Regulator
18	900-2917	Brace, Water Inlet
19	910-2513	Tubing, GSMS Valve to Cookpot
20	910-2926	Tubing, GSW/GWB Valve to Faucet

WIRING DIAGRAM (FOR UNITS MANUFACTURED OCTOBER 2000 AND LATER)

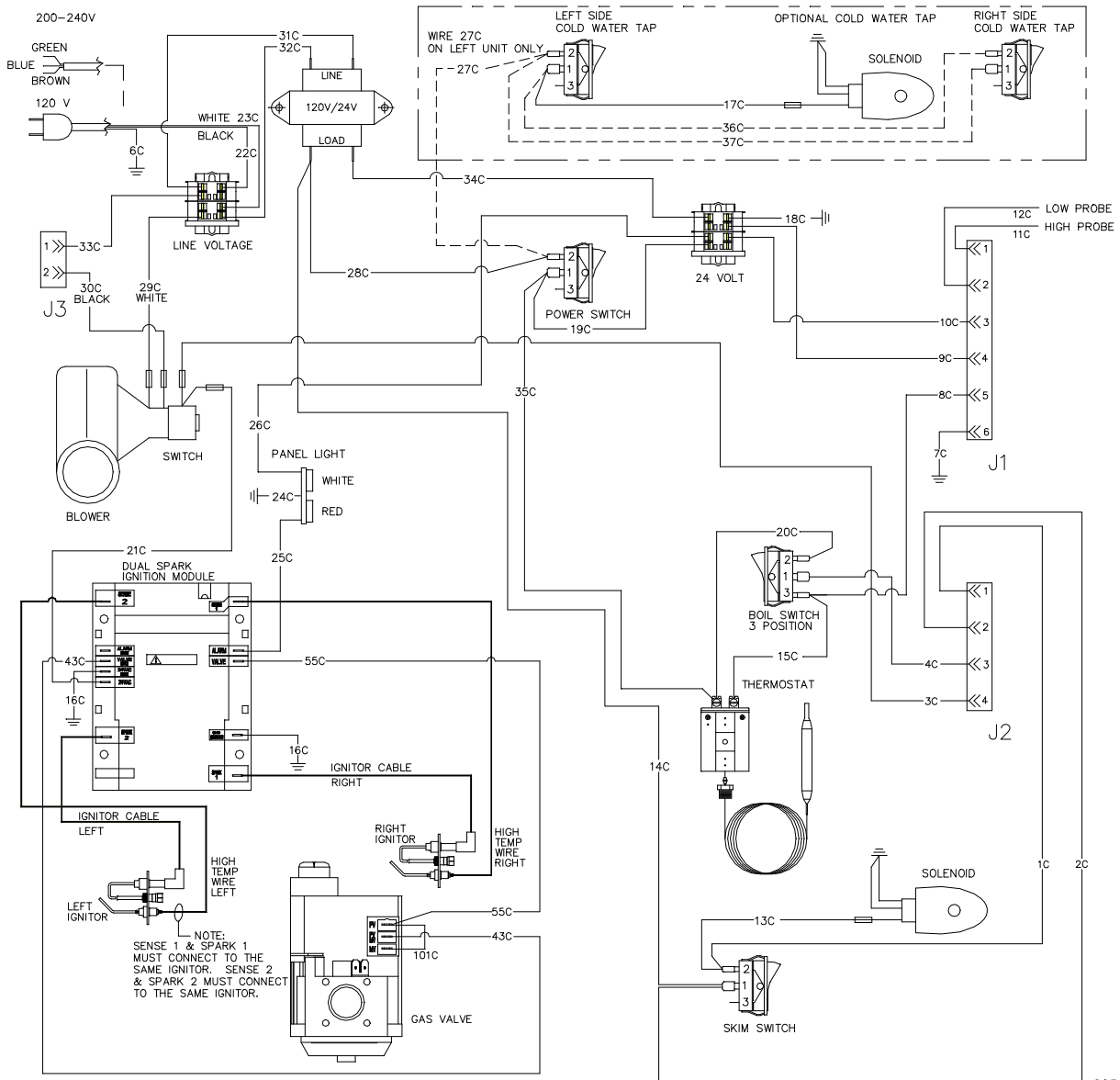

8050521F

WIRING DIAGRAM (FOR UNITS MANUFACTURED PRIOR TO OCTOBER 2000)

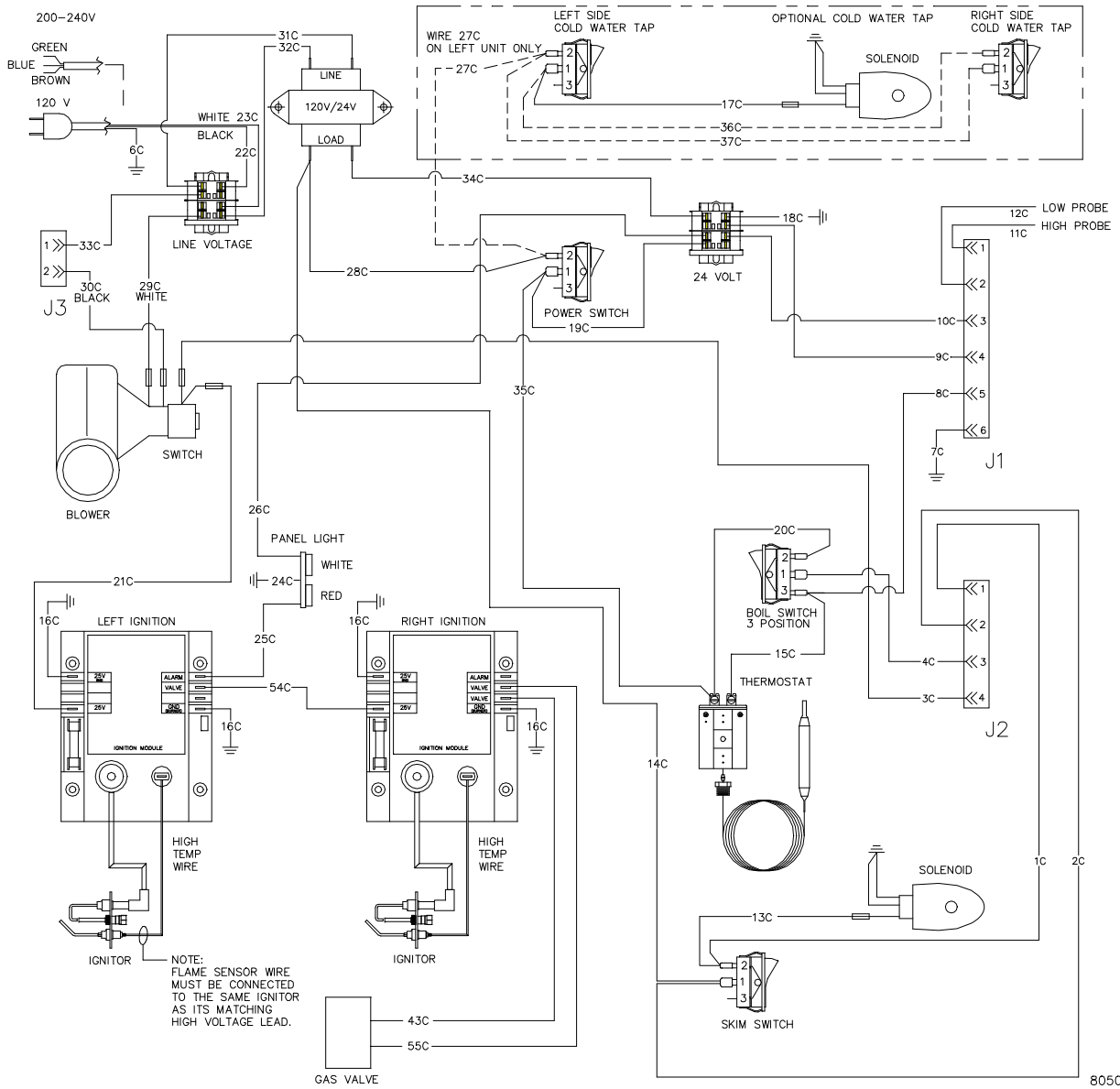



Shipping Address: 8700 Line Avenue, Shreveport, Louisiana 71106

TEL 1-318-865-1711

FAX (Parts) 1-318-219-7140

(Tech Support) 1-318-219-7135

PRINTED IN THE UNITED STATES

SERVICE HOTLINE
1-800-551-8633

Price: \$8.00
819-5312

JAN 2013