

FilterQuick™ FQG30 Gas Fryer

Service Manual

This manual is updated as new information and models are released. Visit our website for the latest manual.



FOR YOUR SAFETY

Do Not Store or use gasoline or other flammable vapors and liquids in the vicinity of this or any other appliance.



Part Number: FRY_SM_8197109 10/2023

Original Instructions

NOTICE

IF, DURING THE WARRANTY PERIOD, THE CUSTOMER USES A PART FOR THIS FRYMASTER DEAN EQUIPMENT OTHER THAN AN UNMODIFIED NEW OR RECYCLED PART PURCHASED DIRECTLY FROM FRYMASTER DEAN OR ANY OF ITS AUTHORIZED SERVICERS, AND/OR THE PART BEING USED IS MODIFIED FROM ITS ORIGINAL CONFIGURATION, THIS WARRANTY WILL BE VOID. FURTHER, FRYMASTER DEAN AND ITS AFFILIATES WILL NOT BE LIABLE FOR ANY CLAIMS, DAMAGES OR EXPENSES INCURRED BY THE CUSTOMER WHICH ARISE DIRECTLY OR INDIRECTLY, IN WHOLE OR IN PART, DUE TO THE INSTALLATION OF ANY MODIFIED PART AND/OR PART RECEIVED FROM AN UNAUTHORIZED SERVICER.

NOTICE

This appliance is intended for professional use only and is to be operated by qualified personnel only. A Frymaster Factory Authorized Servicer (FAS) or other qualified professional should perform installation, maintenance, and repairs. Installation, maintenance, or repairs by unqualified personnel may void the manufacturer's warranty. See Chapter 1 of this manual for definitions of qualified personnel.

NOTICE

This equipment must be installed in accordance with the appropriate national and local codes of the country and/or region in which the appliance is installed. See NATIONAL CODE REQUIREMENTS in Chapter 2 of this manual for specifics.

NOTICE TO U.S. CUSTOMERS

This equipment is to be installed in compliance with the basic plumbing code of the Building Officials and Code Administrators International, Inc. (BOCA) and the Food Service Sanitation Manual of the U.S. Food and Drug Administration.

NOTICE

Drawings and photos used in this manual are intended to illustrate operational, cleaning and technical procedures and may not conform to onsite management operational procedures.

NOTICE

This appliance is intended to be used for commercial applications, for example in kitchens of restaurants, canteens, hospitals and in commercial enterprises such as bakeries, butcheries, etc., but not for continuous mass production of food.

NOTICE TO OWNERS OF UNITS EQUIPPED WITH CONTROLLERS

U.S.

This device complies with Part 15 of the FCC rules. Operation is subject to the following two conditions: 1) This device may not cause harmful interference, and 2) This device must accept any interference received, including interference that may cause undesired operation. While this device is a verified Class A device, it has been shown to meet the Class B limits.

CANADA

This digital apparatus does not exceed the Class A or B limits for radio noise emissions as set out by the ICES-003 standard of the Canadian Department of Communications.

 **DANGER**

Improper installation, adjustment, maintenance or service, and unauthorized alterations or modifications can cause property damage, injury, or death. Read the installation, operating, and service instructions thoroughly before installing or servicing this equipment. Only qualified service personnel may convert this appliance to use a gas other than that for which it was originally configured.

 **DANGER**

No structural material on the fryer should be altered or removed to accommodate placement of the fryer under a hood. Questions? Call the Frymaster Service Hotline at 1-800-551-8633.

 **WARNING**

After installation of a gas fryer and after any maintenance to the gas system of a gas fryer-manifold, valve, burners, etc. – check for gas leaks at all connections. Apply a thick soapy solution to all connections and ensure there are no bubbles. There should be no smell of gas.

NOTICE

The Commonwealth of Massachusetts requires any and all gas products to be installed by a licensed plumber or pipe fitter.

 **DANGER**

Adequate means must be provided to limit the movement of this appliance without depending upon the gas line connection. Single fryers equipped with legs must be stabilized by installing anchor straps. All fryers equipped with casters must be stabilized by installing restraining chains. If a flexible gas line is used, an additional restraining cable must be connected at all times when the fryer is in use.

 **CAUTION**

No warranty is provided for any Frymaster fryer used in a mobile or marine installation or concession. Warranty protection is only offered for fryers installed in accordance with the procedures described in this manual. Mobile, marine or concession conditions of this fryer should be avoided to ensure optimum performance.

 **DANGER**

The front ledge of the fryer is not a step! Do not stand on the fryer. Serious injury can result from slips or contact with the hot oil.

 **DANGER**

Do not store or use gasoline or other flammable liquids or vapors in the vicinity of this or any other appliance.

 **DANGER**

Do not spray aerosols in the vicinity of this appliance while it is in operation.

 **DANGER**

Instructions to be followed in the event the operator smells gas or otherwise detects a gas leak must be posted in a prominent location. This information can be obtained from the local gas company or gas supplier.

 **DANGER**

This product contains chemicals known to the state of California to cause cancer and/or birth defects or other reproductive harm.

Operation, installation, and servicing of this product could expose you to airborne particles of glasswool or ceramic fibers, crystalline silica, and/or carbon monoxide. Inhalation of airborne particles of glasswool or ceramic fibers is known to the State of California to cause cancer. Inhalation of carbon monoxide is known to the State of California to cause birth defects or other reproductive harm.

 **DANGER**

The crumb tray in fryers equipped with a filter system must be emptied into a fireproof container at the end of frying operations each day. Some food particles can spontaneously combust if left soaking in certain shortening material.

 **WARNING**

Do not bang fry baskets or other utensils on the fryer's joiner strip. The strip is present to seal the joint between the fry vessels. Banging fry baskets on the strip to dislodge shortening will distort the strip, adversely affecting its fit. It is designed for a tight fit and should only be removed for cleaning.

 **DANGER**

Improper installation, adjustment, maintenance or service, and unauthorized alterations or modifications can cause property damage, injury, or death. Read the installation, operating, and service instructions thoroughly before installing or servicing this equipment.

NOTICE

The appliance must be installed and used in such a way that any water cannot contact the fat or oil.

 **DANGER**

Keep all items out of drains. Closing actuators may cause damage or injury.

 **DANGER**

Prior to movement, testing, maintenance and any repair on your Frymaster fryer; disconnect ALL electrical power cords from the electrical power supply.

 **WARNING**

Use caution and wear appropriate safety equipment to avoid contact with hot oil or surfaces that may cause severe burns or injury.

FILTERQUICK™ FQG30 SERIES GAS FRYERS
SERVICE MANUAL
TABLE OF CONTENTS

CHAPTER 1: Service Procedures

1.1	Functional Description.....	1-1
1.2	The Electronic Ignition System.....	1-1
1.3	Interface Board	1-2
1.4	Thermostats.....	1-4
1.5	Accessing Fryers for Servicing	1-4
1.6	Cleaning the Gas Valve Vent Tube	1-4
1.7	Checking the Burner Manifold Gas Pressure	1-5
1.8	Measuring Flame Current	1-6
1.9	Replacing Fryer Components	1-6
1.9.1	Replacing the Controller or the Controller Wiring Harness	1-6
1.9.2	Replacing the Temperature Probe or High-Limit Thermostat	1-7
1.9.3	Replacing the Interface Board.....	1-7
1.9.4	Replacing an Ignition Module.....	1-8
1.9.5	Replacing an Ignitor Assembly	1-8
1.9.6	Replacing or Cleaning a Combustion Air Blower.....	1-8
1.9.7	Adjusting the Air/Gas Mixture.....	1-10
1.9.8	Replacing a Gas Valve	1-10
1.9.9	Replacing a Burner Assembly.....	1-11
1.9.10	Replacing the Filter Motor, Filter Pump, or Filter Pump.....	1-12
1.9.11	Replacing the Frypot.....	1-12
1.9.12	Replacing Frypot Insulation and/or Upper Burner Rails.....	1-13
1.10	Troubleshooting and Problem Isolation.....	1-16
1.10.1	Heating (Ignition) Failure.....	1-16
1.10.2	Improper Burner Function.....	1-17
1.10.3	Improper Temperature Control.....	1-18
1.10.4	Controller Malfunctions	1-19
1.10.5	Filtration Malfunctions	1-19
1.10.6	Leakage.....	1-20
1.11	Troubleshooting Guides.....	1-20
1.11.1	Troubleshooting the 24 VAC Circuit	1-20
1.11.2	Troubleshooting the Gas Valve	1-22
1.11.3	Troubleshooting the Temperature Probe.....	1-23
1.11.4	Replacing the Transformer or Filter Relay.....	1-23
1.12	Basket Lift Service Procedures.....	1-24
1.13	Probe Resistance Chart	1-26
1.14	ATO (Automatic Top-Off) Service Procedures.....	1-26
1.14.1	ATO (Automatic Top-Off Troubleshooting).....	1-26
1.14.2	ATO (Automatic Top-Off Troubleshooting) Board Pins and Positions	1-28
1.14.3	Replacing the ATO Board or Transformer	1-29
1.14.4	Replacing the ATO Pump or Solenoid.....	1-29
1.15	MIB (Manual Interface Board) Service Procedures.....	1-29
1.15.1	Manually Draining, Refilling or Filtering Using the MIB Board.....	1-30
1.15.2	MIB (Manual Interface Board) Troubleshooting.....	1-31
1.15.3	MIB (Manual Interface Board) Pin Positions and Harnesses	1-33
1.15.4	MIB (Manual Interface Board) Display Characters	1-34
1.15.5	Replacing the MIB Board.....	1-34
1.15.6	Control Power Reset Switch.....	1-35
1.16	Bulk Oil Service Issues.....	1-35
1.16.1	Bulk MIB Tests.....	1-35
1.16.2	Bulk Wiring.....	1-36
1.16.3	Bulk Oil Plumbing Schematic	1-37
1.16.4	Bulk Oil Test Quick Reference.....	1-37

1.17	AIF (Automatic Intermittent Filtration) Service Procedures.....	1-39
1.17.1	AIF (Automatic Intermittent Filtration) Troubleshooting.....	1-39
1.17.2	AIF (Automatic Intermittent Filtration) Actuator Board Pin Positions	1-41
1.17.3	Replacing an AIF (Automatic Intermittent Filtration) Board.....	1-42
1.17.4	Replacing a Rotary Actuator.....	1-42
1.17.5	Oil Level Sensor	1-42
	1.17.5.1 Oil Level Sensor Troubleshooting.....	1-43
	1.17.5.2 Oil Level Sensor Diagram.....	1-44
1.18	FilterQuick™ Controller Service Procedures.....	1-44
1.18.1	FilterQuick™ Controller Troubleshooting.....	1-44
1.18.2	FilterQuick™ Useful Codes and Passwords	1-47
1.18.3	Service Required Errors.....	1-48
1.18.4	Error Log Codes.....	1-48
1.18.5	FilterQuick™ Filter Error Flowchart.....	1-50
1.18.6	Clogged Drain/Failed Oil Sensor Flowchart	1-51
1.18.7	Menu Trees	1-52
	1.18.7.1 FilterQuick™ Controller Setup Menu Tree	1-52
	1.18.7.2 FilterQuick™ Filter and Info Mode Menu Tree.....	1-53
1.18.8	FilterQuick™ Board Pin Positions and Harnesses.....	1-54
1.18.9	OQS (Oil Quality Sensor) Troubleshooting	1-55
1.19	Loading and Updating Software Procedures.....	1-56
1.20	Principal Wiring Connections.....	1-57
1.21	Wiring Diagrams	1-58
1.21.1	Main FQG 230/430 120V Export.....	1-58
1.21.1.2	Main FQG 230/430 CE Fenwal Module GIVEC	1-59
1.21.2	Main FQG 230/430 Australia.....	1-60
1.21.3	Main FQG 230/430 120V Export with Solid Shortening.....	1-61
1.21.3.2	Main FQG 230/430 CE Fenwal GIVEC with Solid Shortening.....	1-62
1.21.4	Main FQG 230/430 Australia with Solid Shortening.....	1-63
1.21.5	Main FQG 330/530 120V Export.....	1-64
1.21.5.2	Main FQG 330/530 CE Fenwal GIVEC.....	1-65
1.21.6	Main FQG 330/530 Australia.....	1-66
1.21.7	Main FQG 330/530 120V Export with Solid Shortening.....	1-67
1.21.7.2	Main FQG 330/530 CE Fenwal GIVEC with Solid Shortening.....	1-68
1.21.8	Main FQG 330/530 Australia with Solid Shortening.....	1-69
1.21.9	Transformer/Filter Box 430/530	1-70
1.22	Simplified Wiring Diagrams	1-71
1.22.1	FilterQuick™ FQG30 Series Simplified Wiring with Push Pull Handles.....	1-71
1.22.2	FilterQuick™ FQG30 Series Simplified Wiring with Push Pull Handles.....	1-72
1.22.3	FilterQuick™ FQG30 Series Data Network Flowchart.....	1-73
1.23	Alternate Time Delay Relay Wiring Diagrams	1-74
1.24	Shortening Melting Unit Wiring Diagram	1-75
1.25	Basket Lift 100-120v Wiring Diagram	1-76
1.26	Basket Lift 208-250v Wiring Diagram – <i>Prior to 1706</i>	1-77
1.27	Basket Lift 208-250v Wiring Diagram – <i>After 1706</i>	1-78
1.28	Basket Lift Wiring Harness Diagram	1-79

FILTERQUICK™ FQG30 SERIES GAS FRYERS

CHAPTER 1: SERVICE PROCEDURES

1.1 Functional Description

FilterQuick™ FQG30 Series gas fryers contain a welded stainless steel frypot that is directly heated by a high efficiency infrared burner system, requiring approximately 43% less energy than conventional burners to cook the same volume.

Self-contained combustion chambers (referred to as “burners”) are fitted into rails attached to the sides of the frypot, one on each side. Each combustion chamber is fitted with special ceramic tiles that are heated by the burning of a forced air/gas mixture. The tiles transfer heat to the frypot by means of infrared radiation, providing much more constant and uniform heat dispersion over the surface of the frypot than do conventional burners. Because less heat is lost to the atmosphere in the process, compared to “open-burner” designs, less fuel is required to achieve and maintain a given frypot temperature.

In full-vat units, gas flow to both of the burners is regulated by one electromechanical gas valve. In dual-vat units, each burner has its own valve. All fryers in this series are equipped with 24 VAC gas valve systems, and all are configured with electronic ignition.

1.2 The Electronic Ignition System

An ignition module mounted below the component box (located behind the control panel) is connected to an ignitor assembly at the burner. The ignition module performs four important functions: it provides fuse protection for the 24-volt circuit, provides an ignition spark, supplies voltage to the gas valve, and proofs the burner flame. The module contains a four second time delay circuit and a coil that activates the gas valve. All full and dual vat fryers use two single-spark modules.

The ignitor assembly consists of a spark plug, an enrichment tube, and a flame sensor.

At start-up, the power switch is placed in the ON position, supplying approximately 12-volts DC to the heat-control circuitry in the controller and to one side of the heat relay coils on the interface board. If resistance in the temperature probe indicates the temperature in the frypot is below 180°F (82°C), the current flows through a melt cycle circuit where a timer switch alternately closes for six seconds and opens for 24 seconds. If the temperature is 180°F (82°C) or above, the current flows through a heat circuit, bypassing the timer switch. In either case, ground is supplied to the other leg of the heat relay coils, which closes electronic switches in the 24 VAC circuit to provide current to the ignition module. Circuitry in the ignition module sends 24 VAC to the gas valve via a normally closed high-limit switch, and an oil level sensor which is controlled by electronics inside an egg shaped housing. Simultaneously, the module causes the ignitor to spark for four seconds to light the burner. A flame sensor verifies the burner ignition by measuring the flow of micro amps through the flame. If the burner does not light (or is extinguished), current to the ignition module is cut, the gas valve closes, and the ignition module “locks out” until the power switch is turned off and then back on. A probe monitors the temperature in the frypot. When the programmed setpoint temperature is reached, resistance in the probe causes the heat cycle circuitry in the controller to cut off current flow through the heat relay. This in turn cuts off the 24 VAC to the ignition module, causing the gas valve to close.

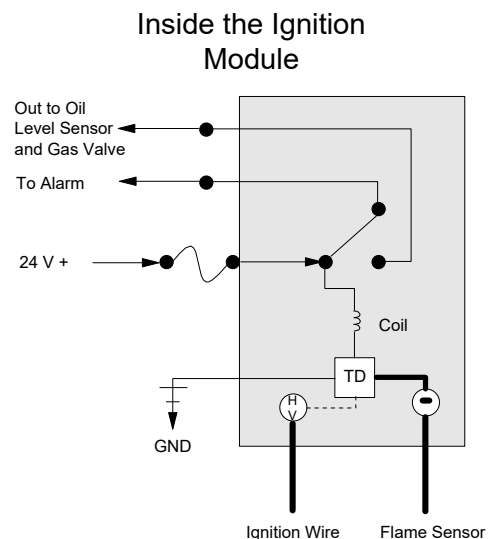

The blower is on during the heating cycle. The blower also turns on if the oil temperature exceeds 2°F above setpoint and during filtration to help cool the frypot to minimize caramelization of the oil on the frypot interior.

1.3 Interface Board

All fryers in this series have an interface board located in the component box behind the control panel. The interface board provides a link between the controller and the fryer's individual components without requiring excessive wiring, and allows the controller to execute commands from one central point.

K2 and K3 are double-pole-double throw (DPDT) relays that supply 24VAC to the ignition and gas valve circuits, as well as 120VAC to the blower motor. The relays on this board plug into sockets. If a relay fails, that relay can be replaced. K1 and K4 are single-pole-double throw (SPDT) relays that supply voltage to the basket lifts.

LEDs (labeled D1 through D7) are arrayed around the board to assist in troubleshooting.

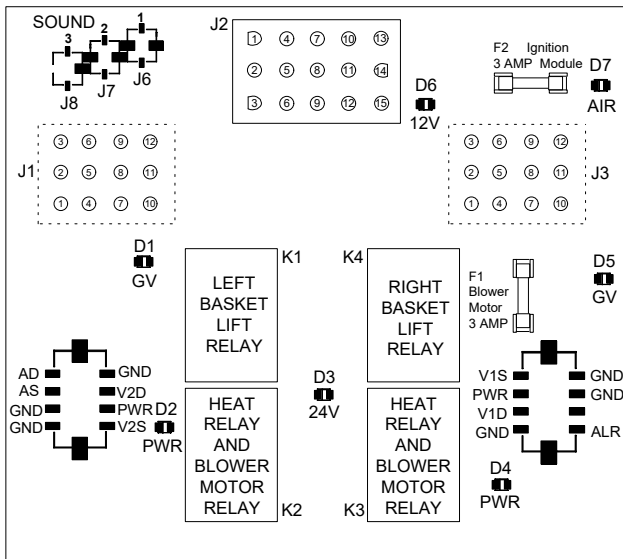

SMT INTERFACE BOARD KIT 826-2264 (106-6706)

INTERFACE BOARD LED DIAGNOSTIC LIGHTS	
D1	24 VAC to left gas valve (dual vat only)
D2	24 VAC to left ignition module
D3	24 VAC from transformer
D4	24 VAC to right ignition module
D5	24 VAC to gas valve (right valve if dual vat)
D6	12 VAC from transformer
D7	CE and Japanese units only: air switch closed

NOTE: Refer to Section 1.11.1 on page 1-20 for troubleshooting flowchart.

NOTE: In full-vat fryers, the relay for the left side (K2) may not be present.

The chart on the following page illustrates current flow through the board, and the table at the top of page 1-4 identifies frequently used test points.

INTERFACE BOARD

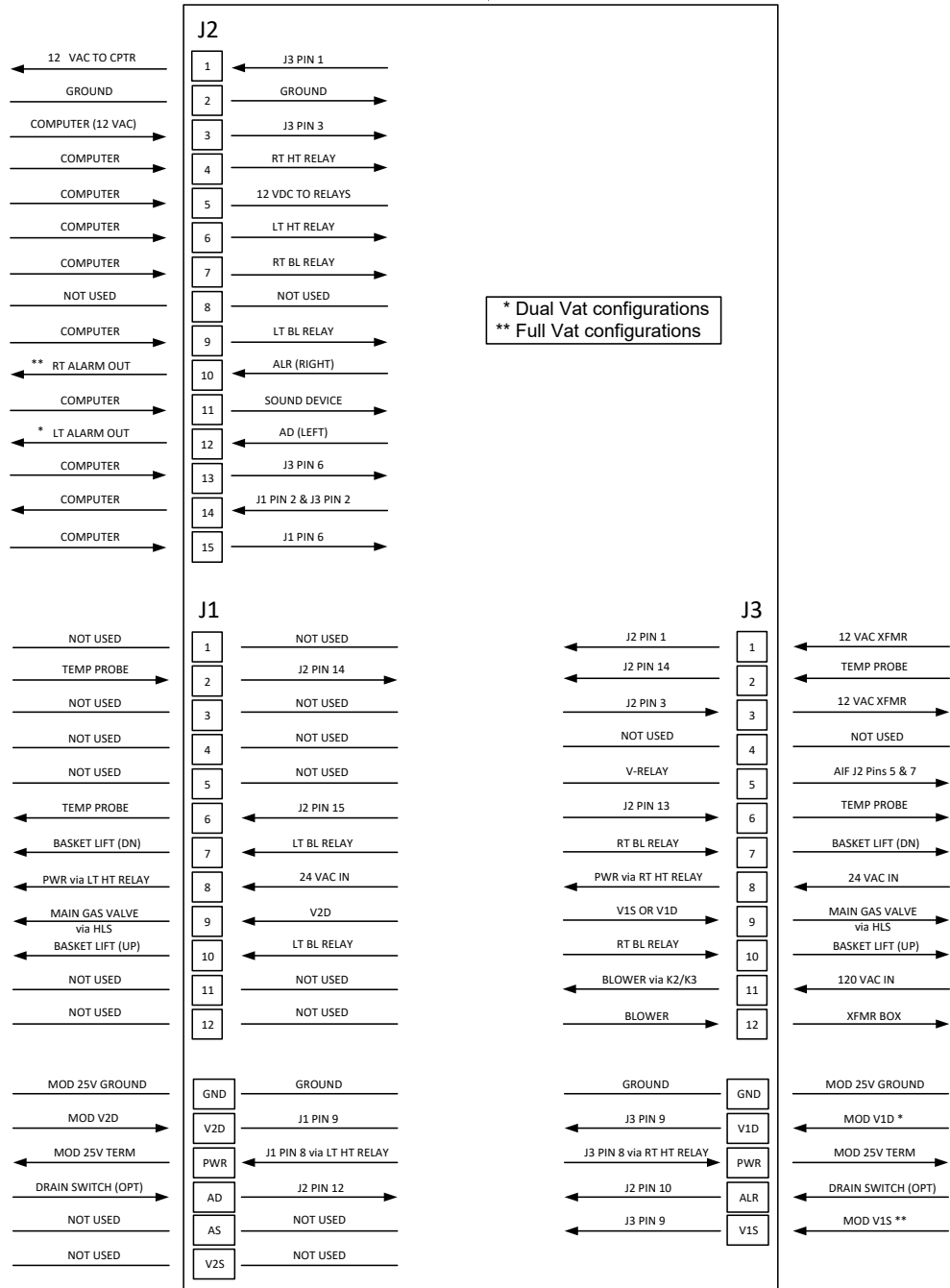

LEFT VAT

FULL OR RIGHT VAT

CURRENT FLOW THROUGH INTERFACE BOARD 106-6706
(SMT HE SERIES APPLICATION)

FREQUENTLY USED TEST POINTS FOR INTERFACE BOARD 106-6706			
Test	Meter Setting	Pins	Results
12VAC Power to Controller	50VAC Scale	1 and 3 on J3 or J2	12-18
24VAC Power to Right Module	50VAC Scale	8 on J3 and GROUND	22-28
24VAC Power to Left Module (if present)	50VAC Scale	8 on J1 and GROUND	22-28
120 VAC Power	250VAC Scale	11 on J3 and GROUND	110-125
120 VAC Power to Blowers	250VAC Scale	12 on J3 and GROUND	110-125
24VAC Power to Full- or Right-vat High-Limit	50VAC Scale	9 on J3 and GROUND	22-28
24VAC Power to Left High-Limit (if present)	50VAC Scale	9 on J1 and GROUND	22-28
Probe Resistance (Full- or Right-vat) *	R x 1000 OHMS	2 and 6 on J3 or 13 and 14 on J2	**
Probe Resistance (Left - if present) *	R x 1000 OHMS	2 and 6 on J1 or 14 and 15 on J2	**
Probe Isolation	R x 1000 OHMS	6 on J1 or J3 and GROUND	***
High-Limit Continuity (Full- or Right-vat)	R x 1 OHM	9 on J3 and Wire 13C on Gas Valve	0
High-Limit Continuity (Left - if present)	R x 1 OHM	9 on J1 and Wire 12C on Gas Valve	0
* Disconnect 20-pin harness from controller before testing probe circuit.			
** See Probe Resistance Chart at end of chapter.			
*** 5 mega-Ohms or greater.			

1.4 Thermostats

FilterQuick™ FQG30 Series gas fryers have *temperature probes* located on the front centerline of each frypot (dual-vat frypots have two probes, one in each vat). In this type of thermostat, the probe resistance varies directly with the temperature. That is, as the temperature rises, so does resistance, at a rate of approximately 2 ohms for every 1° F. Circuitry in the controller monitors the probe resistance and controls burner firing when the resistance exceeds or falls below programmed temperatures (setpoints).

FilterQuick™ FQG30 Series gas fryers are also equipped with a *high-limit thermostat*. In the event that the fryer fails to properly control the oil temperature, the high-limit thermostat prevents the fryer from overheating to the flash point. The high-limit thermostat acts as a normally closed power switch that opens when exposed to temperatures above 425°F to 450°F (218°C to 232°C). The different types of thermostats have different part numbers for CE and Non-CE models, and are not interchangeable.

1.5 Accessing Fryers for Servicing



DANGER

Moving a fryer filled with oil may cause spilling or splattering of the hot liquid. Follow the draining instructions on page 1-13 thru 1-15 of the FilterQuick™ Controller Manual (P/N 819-7050) before attempting to relocate a fryer for servicing.

1. Shut off the gas supply to the unit. Unplug the power cords. Disconnect the unit from the gas supply.
2. Remove any attached restraining devices and relocate the fryer for service accessibility.
3. After servicing is complete, reconnect the unit to the gas supply, reattach restraining devices, and plug in the electrical cords.

1.6 Cleaning the Gas Valve Vent Tube

1. Set the fryer power switch and the gas valve to the OFF position.
2. Carefully unscrew the vent tube from the gas valve. **NOTE:** The vent tube may be straightened for ease of removal.
3. Pass a piece of ordinary binding wire (.052 inch diameter) through the tube to remove any obstruction.
4. Remove the wire and blow through the tube to ensure it is clear.
5. Reinstall the tube and bend it so that the opening is pointing downward.

1.7 Checking the Burner Manifold Gas Pressure

1. **On non-CE fryers only** ensure that the gas valve knob is in the OFF position.

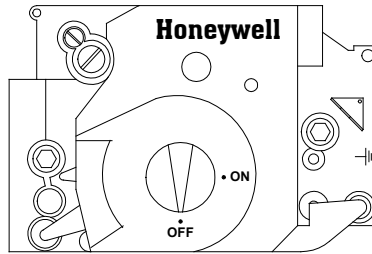

2. Remove the pressure tap plug from the gas valve assembly.

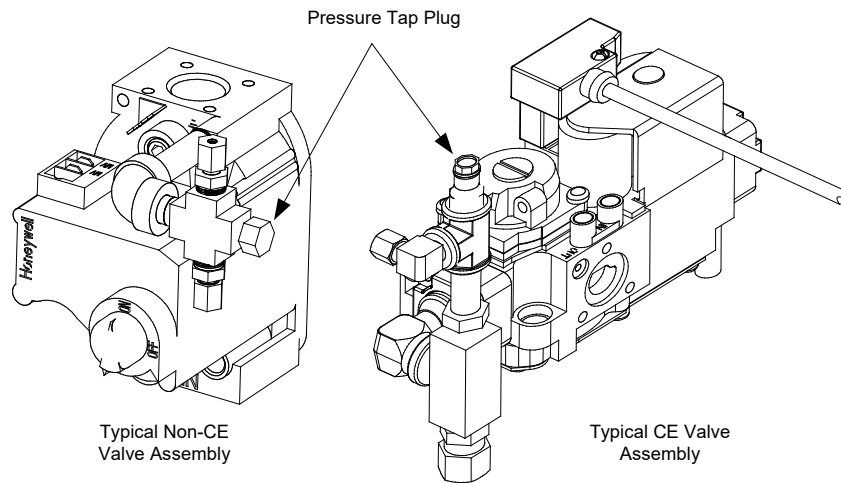

3. Insert the fitting for a gas pressure-measuring device into the pressure tap hole.
4. **On non-CE fryers only**, place the gas valve in the ON position
5. Place the fryer power switch in the ON position. When the burner has lit and burned steadily for at least one minute, compare the gas pressure reading to the pressure for the corresponding gas in the appropriate table on the following page. The tables list the burner manifold gas pressures for each of the gas types that can be used with this equipment.

CE Standard Burner Manifold Gas Pressures		
Gas	Pressure (mbar)	
	Single Vat	Dual Vat
Natural Gas Lacq (G20) under 20 mbar	7	8
Natural Gas Gronique* (G25) under 25 mbar	10	11.2
Natural Gas Gronique (G25) under 20 mbar	10	11.2
Butane/Propane (G30) at 28/30 or 50 mbar	17	17
Propane (G31) under 37 or 50 mbar	20.6	20.6

* Belgian G25 = 7,0 mbar (single or dual)

Non-CE Standard Burner Manifold Gas Pressures	
Gas	Pressure
Natural	3.20" W.C. 0.80 kPa
Propane	8.25" W.C. 2.5 kPa

- To adjust the burner gas pressure, remove the cap from the gas valve regulator and adjust to the correct pressure.

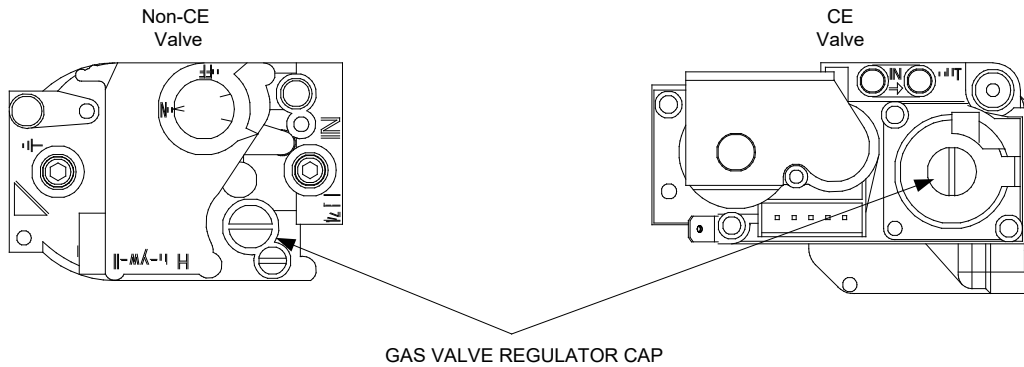

- Place the fryer power switch (and the gas valve in non-CE fryers) in the OFF position. Remove the fitting from the pressure tap hole and reinstall the pressure tap plug.

1.8 Measuring Flame Current

When the burner flame is properly adjusted, it will typically produce a current between $0.3\mu\text{A}$ and $0.9\mu\text{A}$ on Capable Control modules or between $3.0\mu\text{A}$ and $8.0\mu\text{A}$ on Honeywell modules. Lockouts can occur at currents $0.15\mu\text{A}$ or below on Capable Control modules or $0.9\mu\text{A}$ or below on Honeywell modules. Flame current is measured by placing a *microamp* (not milliamp) meter in series with the sensing wire on the ignitor. This is accomplished as follows:

- Place the fryer power switch in the OFF position.
- Disconnect the sensing wire from one of the burner ignitors and connect it to the positive lead of the meter. Connect the negative lead of the meter to the terminal from which the sensing wire was removed.

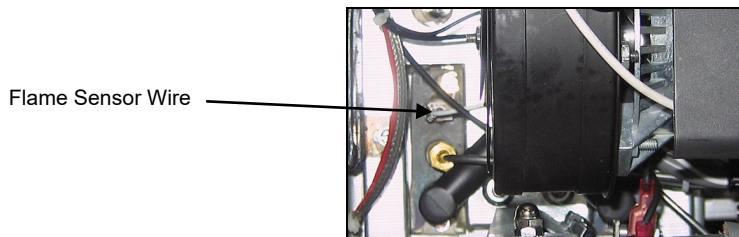

- Place the fryer power switch in the ON position to light the burners. After the frypot temperature reaches 200°F (93°C), wait at least one minute before checking the reading. **NOTE:** The closer the unit is to normal operating temperature, the more accurate the reading will be.

1.9 Replacing Fryer Components

1.9.1 Replacing the Controller or the Controller Wiring Harnesses

- Disconnect the fryer from the electrical power supply.
- Unscrew the filter push pull handle knobs.
- Open the control panel by removing the screws on the bottom of the bezel. Carefully lower the bezel.
- Remove the two screws from the upper corners of the controller. The controller is hinged at the bottom and will swing open from the top.
- Unplug the wiring harnesses from the connectors on the back of the controller marking their position for reassembly and disconnect the grounding wires from the terminals. Remove the controller by lifting it from the hinged slots in the control panel frame.

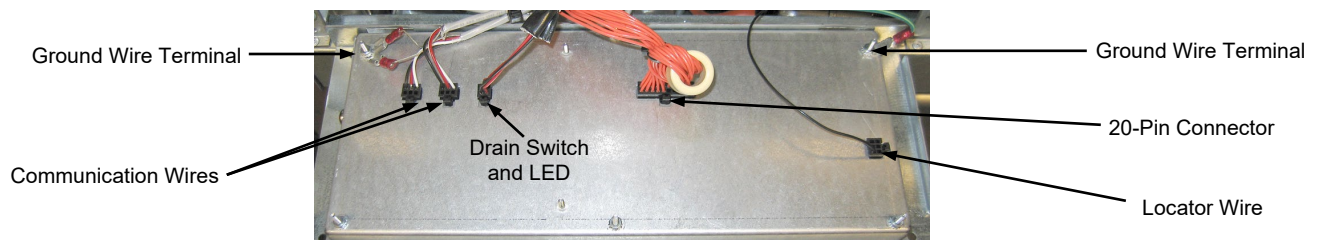

5. Install the replacement controller. Reinstall the control panel assembly by reversing steps 1 thru 5.
6. Setup the controller following the instructions on page 1-3 in the FilterQuick™ Controller Operation manual. Setup **MUST** be performed prior to readdress.
7. Once setup is complete on all replaced controllers, CYCLE POWER TO ENTIRE FRYER SYSTEM. See section 1.15.6 to reset control power.
8. Check software version and if necessary update the software. If a software update was necessary, follow the instructions to update the software in section 1.19.

1.9.2 Replacing the Temperature Probe, ATO Probe, AIF Probe, Oil Level Sensor or High-Limit Thermostat

1. Disconnect the fryer from the electrical supply.
2. Drain cooking oil below the level of the probe or thermostat.
3. Unscrew the filter push pull handle knobs.
4. Open the control panel by removing the screws on the bottom of the bezel. Carefully lower the bezel.
5. Remove the top two screws in the upper corners of the controller.
6. Swing the controller out from the top and allow it to rest on its hinge tabs.
7. Disconnect the controller wiring harness and ground wire from the back of the controller and remove the controller by lifting it from the hinge slots in the control panel frame.
8. Disconnect the ignition cables from the ignitors by grasping the boots and gently pulling toward you.
9. Disconnect the flame sensor wires from the flame sensors.
10. Disconnect the sound device lead from the interface board.
11. If working on the left frypot, cut the wire tie on the wiring bundle and disconnect the main wiring harness 15-pin connector.
12. Remove the component box mounting screws.
13. Rotate the top of the component box out of the frame and carefully pull it out enough to disconnect the wiring harness plug from the back of the box. This will leave one set of wires, enclosed in spiral wrap, connected to the component box.
14. Remove the box and set it atop the fryer to expose the temperature probe and high-limit thermostat.
15. Unscrew the probe or thermostat from the frypot.
16. Apply Loctite® PST56765 pipe thread sealant or equivalent to the replacement part threads and screw the replacement part into the frypot, torquing to 180 inch-pounds.
17. Connect the wires from the new component as follows:
 - a. If replacing a probe, use a pin pusher to disconnect (one at a time) the red and white leads from the connector and insert the corresponding leads from the new probe into the plug.
 - b. If replacing the high-limit thermostat, use a pin pusher to disconnect the lead running to the connector and insert the corresponding lead from the new thermostat.
 - c. Reverse steps 1 through 14 to complete the procedure.

1.9.3 Replacing the Interface Board

1. Perform steps 1 through 4 from section 1.9.1.
2. Disconnect the wires attached to the interface board, marking or making a note of the wires and terminals to facilitate reconnection.
3. Remove the nuts at each corner of the interface board and carefully pull it from the studs far enough to allow the connector on the back of the board to be disconnected, then remove the board from the box. When removing the board, be careful not to lose the spacers that fit over the studs behind the board.
4. Recover the relay(s) from the failed interface board and install on the replacement board.

- Reverse the procedure to install the replacement board, being sure that the spacers behind the board are in place and the controller locator wire is attached to a stud.

1.9.4 Replacing an Ignition Module

- Disconnect the fryer from the electrical supply.
- Open the control panel by removing the screws on the bottom of the bezel. Carefully lower the bezel.
- Remove the top two screws in the upper corners of the controller.
- Swing the controller out from the top and allow it to rest on its hinge tabs.
- Remove the two screws attaching the module cover.
- Loosen the nuts attached to the screws of the module. Slide the module towards the rear of the component box until the nuts drop through the keyholes.
- Carefully rotate the module and pull forward. On some units it may be necessary to remove the blower.
- Disconnect the wires from the ignition module, marking or making a note of the wires and terminals to facilitate reconnection.
- Remove the screws from the module.
- Move the screws and spacers to the new module.
- Reverse the procedure to install the replacement module.

1.9.5 Replacing an Ignitor Assembly



DANGER

Drain the frypot before proceeding further.

- Disconnect the fryer from the electrical supply.
- Disconnect the flame sensor wire by carefully pulling its push-on terminal from the terminal strip on the ignitor. Disconnect the gas enrichment tube at the ignitor-end compression fitting. Disconnect the ignition cable from the ignitor by grasping its boot and gently pulling toward you. (See photo on the next page)

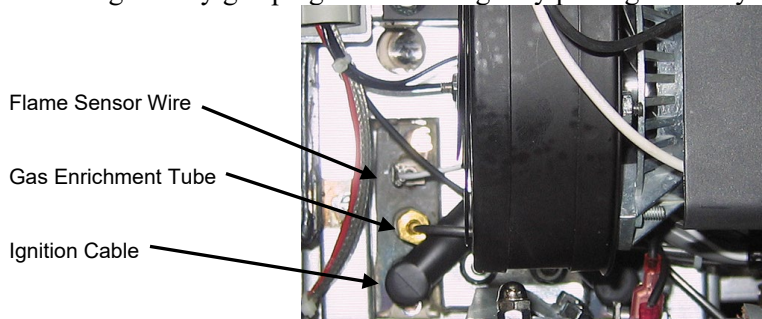

- Remove the sheet metal screws securing the ignitor to the mounting plate and pull the ignitor from the fryer.
- Reverse the procedure to install the replacement ignitor.

1.9.6 Replacing or Cleaning a Combustion Air Blower

- Disconnect the blower wiring harness, remove the blower assembly mounting nuts, and remove the blower assembly from the fryer. If cleaning the motor, continue with Step 2; otherwise, install the replacement blower, reconnect the wiring harness, and then go to Step 6.

**Blower assembly
mounting nuts**

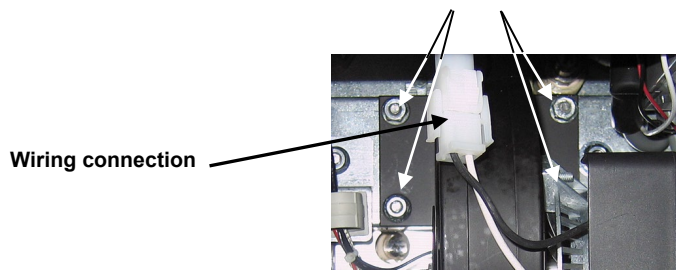

- Remove the blower motor shield and separate the blower motor from the housing as shown in the illustration below.

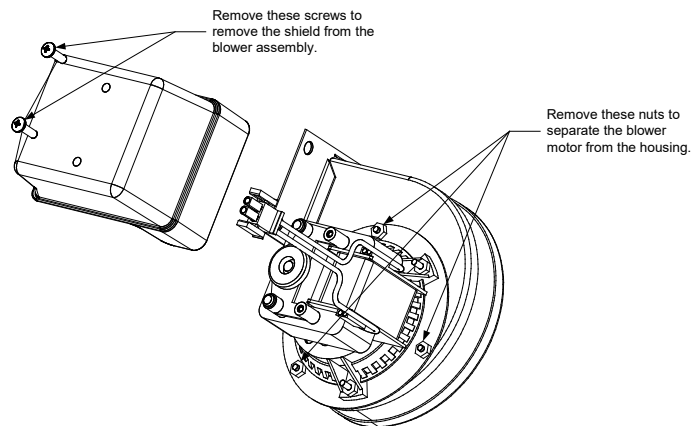

- Wrap the motor with plastic wrap to prevent water from entering it. Spray degreaser or detergent on the blower wheel and the blower housing. Allow it to soak for five minutes. Rinse the wheel and housing with hot tap water, then dry with a clean cloth.

NOTICE- Australia Only
The air pressure switch on the combustion blower should read: Full Vat units-122pa (0.5 inches W.C.) and for Split Vat units-180pa (0.72 inches W.C.).

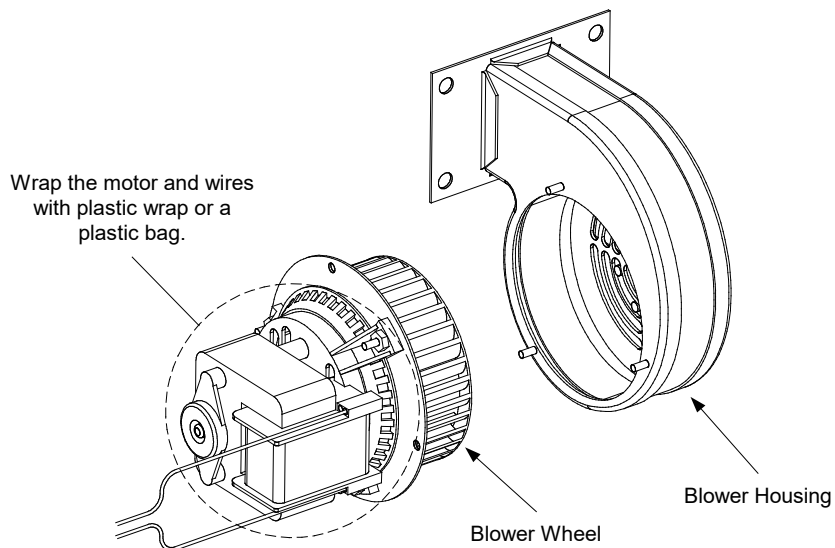

- Remove the plastic wrap from the blower motor assembly. Reassemble the blower motor assembly and blower housing. Reinstall the blower shield.
- Reinstall the blower assembly in the fryer and reconnect the wiring disconnected in Step 1.

6. Light the fryer in accordance with the procedure described in Chapter 3, Section 3.1.2 of the FilterQuick™ FQG30 Series Gas Fryer Installation and Operation Manual (P/N 819-6286).
7. After the burners have been lit for at least 90 seconds, observe the flames through the burner viewing ports located on each side of the combustion air blower.

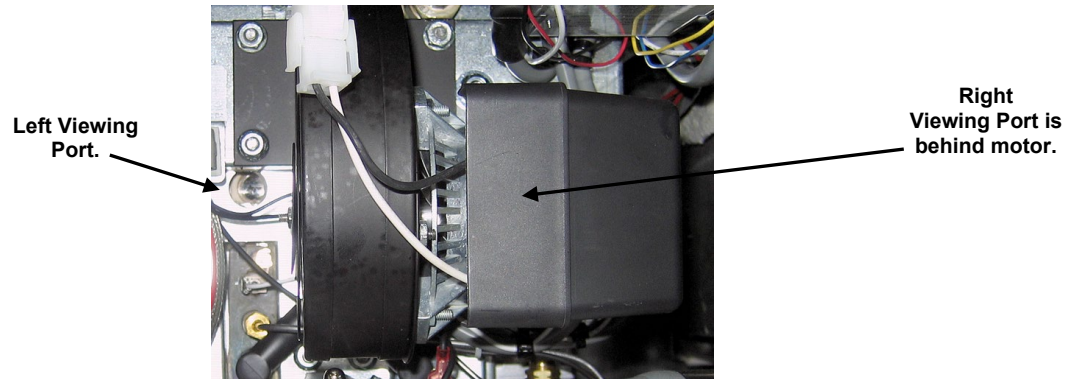

The air/gas mixture is properly adjusted when the burner manifold pressure is in accordance with the applicable table on page 1-5 and the burners display a bright orange-red glow. If a blue flame is observed or if there are dark spots on a burner face, the air/gas mixture requires adjustment.

NOTE: Opening the air shutter too much may result in whistling. It should not be more than 1/3 open.

1.9.7 Adjusting the Air/Gas Mixture

On the side of the blower housing opposite the motor is a shutter plate with a locking nut. Loosen the nut enough to allow the shutter to be moved, then adjust the position of the shutter to open or close the air intake opening until a bright orange-red glow is obtained, then close it slightly. Carefully hold the shutter in position and tighten the locking nut (see illustration on the following page).

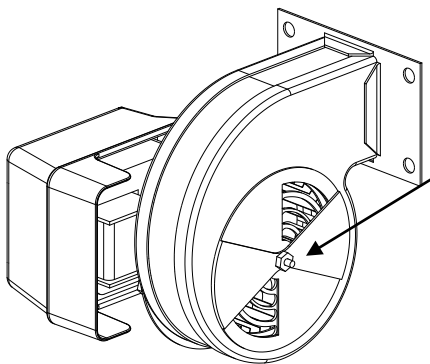

On non-CE blowers loosen this nut and rotate shutter to open or close air intake.

On CE blowers loosen both wing nuts and slide the shutter to adjust the air intake.

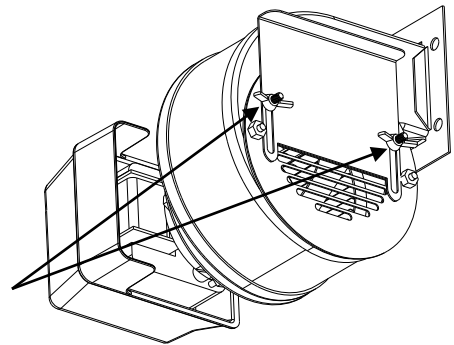

1.9.8 Replacing a Gas Valve

1. Disconnect fryer from electrical and gas supplies.
2. Disconnect the drain safety and high-limit thermostat wires from the gas valve. Mark each wire to facilitate reconnection.
3. Remove the vent tube (on non-CE fryers) and the enrichment tube fitting from the valve. Disconnect the flexible gas line(s).

If replacing the left-most valve on any configuration, or the right valve on a two-fryer battery, follow the instructions below. If replacing valves in other positions, skip to “ALL OTHER VALVES.”

- A. Remove the filter pan from the unit. Remove the door adjacent to the valve being replaced.
- B. Remove the screws on that attach the pan rails adjacent to the valve being replaced.
- C. Uncouple the pipe union and remove the gas valve and associated piping from the unit.

- D. Remove the fittings and associated piping from the failed valve and install them on the replacement valve using Loctite® PST56765 or equivalent pipe thread sealant.
- E. Reconnect the gas valve assembly to the fryer using Loctite® PST56765 or equivalent pipe thread sealant, and reattach the flexible gas line(s), enrichment tube(s), and the vent tube (on non-CE units). Reconnect the high-limit thermostat wires and drain safety wires to the valve.
- F. Reconnect the fryer to the gas supply and open the cut off valve. Apply a thick soapy solution of soapy water around each connection to check for gas leaks and ensure there are no bubbles. Eliminate any that are found. There should be no smell of gas.
- G. Position the pan rail assembly beneath the fryer and rest the rear end of the rail on the cabinet frame. Install the two nuts and bolts behind the front face of the rail, but do not tighten them. Install the nut and bolt at the rear end of the filter rail and tighten securely.
- H. Reattach the screws for the pan rails. Install the filter pan in the unit to make sure that all components are properly aligned.
- I. Reconnect the fryer to the electrical power supply and check for proper operation. When proper operation has been verified, reinstall the door removed in Step A.

ALL OTHER VALVES

4. Carefully unscrew the valve from the manifold. **NOTE:** Some models may have the valve attached to the manifold by means of a pipe union. In such cases, remove the valve by uncoupling the union.
5. Remove all fittings from the old gas valve and install them on the replacement valve, using Loctite® PST56765 or equivalent pipe thread sealant.
6. Reconnect the gas valve assembly to the fryer using Loctite® PST56765 or equivalent pipe thread sealant, and reattach the flexible gas line(s), enrichment tube(s), and the vent tube (on non-CE units). Reconnect the high-limit thermostat wires and drain safety wires to the valve.
7. Reconnect the fryer to the gas supply and open the cut off valve. Apply a thick soapy solution of soapy water around each connection to check for gas leaks and ensure there are no bubbles. Eliminate any that are found. There should be no smell of gas.
8. Reconnect the fryer to the electrical power supply and check for proper operation.

1.9.9 Replacing a Burner Assembly

1. Disconnect the unit from the electrical and gas supplies.
2. Remove the gas line and enrichment tube using a 7/16" and 5/8" wrench from the front of the burner. It may be necessary to remove the MIB board in some locations.
3. Remove the elbow and tee off the bottom of the burner to ensure easier removal of the burner.
4. Remove the fryer back.
5. Remove the screws attaching the flue cap to the brace.
6. Remove the top cross brace in the back.
7. Remove the flue by removing the two screws in the rear and one screw in the front of the flue.
8. Remove all the screws on the flue collector and bend back the tabs and remove the collector.
9. Remove four screws on the collector insulation plate (see Figure 1).
10. Remove the four nuts and cover of the lower insulation retaining cover (see Figure 2).
11. Carefully remove the insulation being careful not to damage it.
12. Grasp the burner firmly and slide the burner out the rear of the fryer. Pull it toward you until it clears the burner channels, taking care not to damage the ceramic tiles in the process.
13. Slide the burner out the rear of the fryer.
14. Clean all debris from the burner channels and combustion area.
15. Inspect the upper and lower burner rails for cracked or burned out welds.



Figure 1

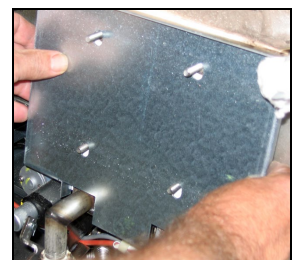

Figure 2

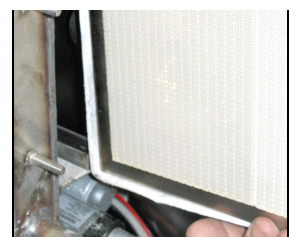

Figure 3

- a. If the welds in the lower rail are cracked or burned out, the frypot must be replaced. Refer to Section 1.9.11 for procedure.
 - b. If the welds in the upper rail are cracked or burned out, the upper rail must be replaced. Refer to Section 1.9.12 for procedure.
16. Wrap a new insulating strip along the top, rear, and bottom edge of the burner. **NOTE:** Use P/N 826-0931 for full-vat frypots and P/N 826-0932 for dual-vat frypots.
 17. Carefully slide the replacement burner into the rails starting at the top and lifting slightly up on the bottom (see Figure 3). Ensure that the insulation is not torn or damaged.
 18. In reverse order reassemble insulation and holding plates.
 19. Install flue collector.
 20. Install the flue.
 21. Install the cross brace ensuring the flue cap is secured to the brace.
 22. Replace the fryer back.
 23. Reattach the elbow, gas line and enrichment tubes to the front of the burner.
 24. Fill the frypot with oil. Turn the fryer on, turn off or bypass the melt cycle, and operate the unit for at least 10 minutes.
 25. Visually examine the burner flame. The color and intensity on both sides should be the same.
 26. Use an inspection mirror to check for leaks in areas that cannot be directly observed.
 27. If a leak is detected, tighten all the lower insulation retainer nuts, allow the frypot to run for five additional minutes, and repeat steps 25 and 26.
 28. If the leak persists, use a rubber hammer and a small block of wood to tap the corners of the lower combustion chamber insulation retainers. Repeat steps 25 through 27. **Repeat this step until no leakage is detected.**

1.9.10 Replacing the Filter Motor or Filter Pump

1. Disconnect the unit from the electrical power supply.
2. Remove the filter pan from the unit.
3. Position a container beneath the oil return fitting at the front of the cabinet. Disconnect the flexible oil line from the fitting, allowing any residual oil to drain into the container.
4. At the rear of the fryer, unplug the left connector (as viewed from the rear of the fryer) from the transformer box.
5. Remove the four nuts and bolts attaching the motor mount to the rear motor mount support.
6. At the front of the fryer, remove the cover plate from the front of the motor and disconnect the motor wires.
7. Place a 1-foot (30.5-cm) length of wood (or similar support) beneath the motor mount near the front of the unit and remove the two remaining nuts and bolts attaching the motor mount to the front cabinet cross-brace.
8. Carefully remove the support and lower the motor mount to the floor, allowing the rear of the mount to slide forward and off the rear motor mount support.
9. Disconnect the return flexline from the pump. The motor and pump assembly can now be pulled from beneath the fryer and the failed component can be removed and replaced.
10. Position the replacement motor and pump assembly beneath the fryer and reconnect the oil return flexline to the pump. Lift the rear of the motor mount up and onto the rear motor mount support.
11. Lift the front of the motor mount up and support it with a 1-foot (30.5-cm) piece of wood or a similar support. Install but do not tighten the two nuts and bolts that attach the motor mount to the front cabinet cross-brace.
12. Install and tighten the four nuts and bolts that secure the motor mount to the rear motor mount support.
13. At the front of the fryer, tighten the two nuts and bolts at the front of the motor mount. Reconnect the motor power wires and reinstall the wiring cover plate.
14. Reconnect the oil return flexline and reinstall the filter pan.
15. Reconnect the unit to the electrical power supply, fill the frypots with oil and check for proper operation.

1.9.11 Replacing the Frypot

1. Disconnect the fryer from the electrical and gas supplies.

2. Remove the filter pan from the unit and drain one frypot at a time into a Shortening Disposal Unit (SDU) or other appropriate metal container using the drain function on the MIB board (see section 1.14 on page 29).

 **DANGER**

DO NOT attempt to drain more than one full frypot or two split frypots into the SDU at one time.

3. Dismount the topcap by removing the screws on the bottom of each front corner and lifting the topcap straight up.
4. Remove the bezels by lifting them up to disengage the tabs along the lower edges from the slots in the control panel frame. Remove the top screws in the upper corners of the controller.
5. Grasp the upper edge of each controller and swing the controller downward. Unplug the controller wiring harness and grounding wire from the back of each controller.
6. Remove the controllers by lifting them from the hinge slots in the control panel frame.
7. Disconnect the sound device wire from the interface board.
8. Disconnect the flame sensor wires by carefully pulling the push-on terminals from the terminal strips on the ignitors. Disconnect the gas enrichment tube at the ignitor-end compression fitting. Disconnect the ignition cables from the ignitors by grasping the boots and gently pulling toward you.
9. Remove the two mounting screws on each side of the component box and rotate the top of the box out of the frame. Carefully pull it out enough to disconnect the wiring harness connector from the back of the box. Cut any ties that prevent the box from being pulled out of the control panel frame.
10. Carefully pull the box clear of the frame and rest it on top of the fryer.
11. Using a pin pusher, remove the temperature probe, high-limit thermostat wires and RTD probe wires from the plugs or terminals, marking each wire to facilitate re-assembly.
12. Disconnect the actuators from the return and drain valves.
13. Remove the section(s) of drain from the drain valve(s) of the frypot to be removed.
14. Disconnect the gas lines from the burner orifices and ignitor assemblies.
15. Remove the frypot hold down bracket.
16. Remove the screws in the back panel and inside the flue cap at each end that secure the flue cap to the fryer and lift it clear of the fryer.
17. Disconnect the oil return line(s) from the frypot to be removed.
18. Disconnect all wiring from the AIF board.
19. Carefully lift the frypot from the fryer cabinet.
20. Remove the drain valve(s), temperature probe(s), high-limit thermostat(s), RTD probes, oil level sensor probes, AIF boards, actuators and ignitor assemblies. Inspect each of these components carefully and install them in the replacement frypot if they are in serviceable condition. Use Loctite® PST56765 sealant or equivalent on component threads.
NOTE: Some servicers, based upon their experience, recommend that probes and thermostats be replaced whenever a frypot is replaced; however, this remains the customer's decision.
21. Reverse steps 1-20 to reassemble fryer.
NOTE: Care should be taken not to over-torque nuts on frypots made of 400-series stainless steel, as this could tear the material. One turn past hand-tight is sufficient torque.
22. Perform steps 14 through 18 of Section 1.9.9 to ensure that there are no leaks in the burner insulation.

 **CAUTION**

Before installing temperature probes, high-limit thermostats, RTD probes, oil level sensor probes, return valves and drain valves on replacement frypot, clean the threads and apply Loctite® PST56765 thread sealant or equivalent.

1.9.12 Replacing Frypot Insulation and/or Upper Burner Rails

NOTE: Replacing the burner rails requires completely tearing down the frypot and installing new frypot insulation. Refer to the frypot exploded view below for component identification.

1. Remove the frypot per Section 1.9.11.
2. Remove the burner assemblies (1).
3. Remove insulation retainers and blanket insulation (2).
4. Remove the upper oil zone insulation bracket and upper oil zone insulation (3).
5. Remove the plenum (4).
6. Remove the front lower combustion chamber insulation retainer and insulation (5), and the front lower combustion chamber inner insulation retainer and insulation (6). **NOTE:** Full-vat units have two-piece insulation retainer and insulation components. Dual-vat units have one-piece components.
7. Remove the upper combustion chamber insulation retainer and insulation (7).
8. Remove the inner upper combustion chamber insulation retainer and insulation (8).
9. Remove the rear lower combustion chamber retainers, back, and insulation (9). **NOTE:** Full-vat units have two-piece backs and four retainers. Dual-vat units have one-piece backs and two retainers.
10. Remove the flue assembly (10).

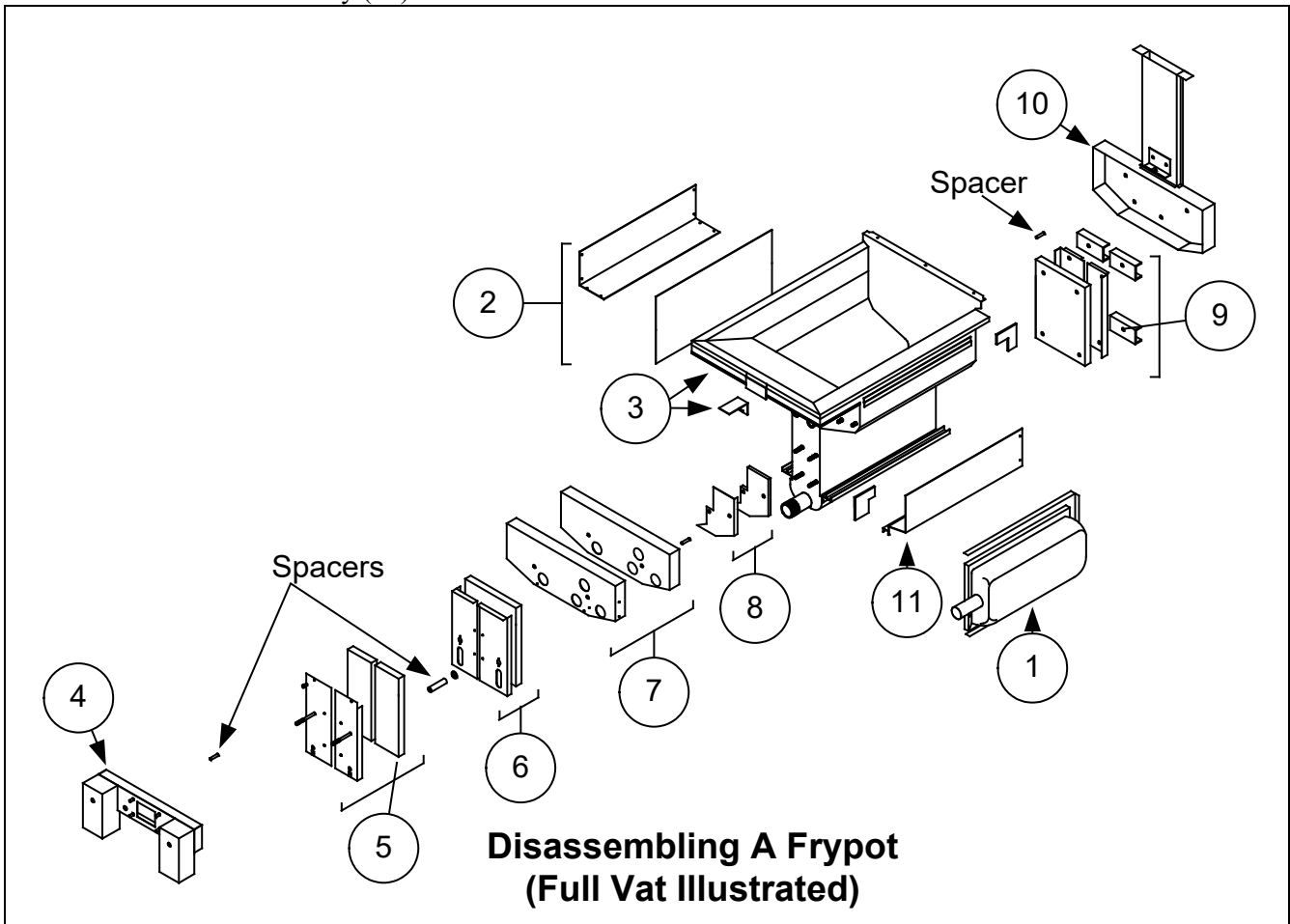

See page 1-16 for reassembly illustration.

11. Remove the upper burner rails (11). **NOTE:** For the following steps, refer to the frypot exploded view on page 1-16 for component identification.
12. Remove any residual insulation, sealant, and/or oil from the exterior of the frypot.
13. Place the “L” shaped pieces of the combustion chamber insulation (1) in the front and rear corners of both upper rail-retaining slots. (See page 1-16).
14. Using a mallet and short piece of wood, tap the corner tabs of the combustion chamber over the insulation to ensure a solid seal of the burner.
15. Install the upper burner rails (2) with the heat deflectors slanting toward the rear of the frypot. The rails will cover the “L” shaped pieces of combustion chamber insulation previously installed.
16. Place the upper inner combustion chamber insulation and insulation retainers (3) on the top two studs on each side of the front of the frypot and secure with ¼”-20 washer-nuts. *It is normal for the retainers to slice off the overhanging insulation.*

17. Place the lower rear combustion chamber insulation (4) on the lower four studs at the rear of the frypot.
18. Place one 1.625-inch tubular spacer (5) on each of the flue assembly (upper) studs at the rear of the frypot. **NOTE:** There are three different sizes of spacers. Verify the size to ensure the correct spacers are installed.
19. Press the flue assembly (6) over the burner rails. It may be necessary to use a rubber mallet or screwdriver to align the components. Use four ¼"-20 washer nuts to secure the flue assembly. **Do not tighten the retainer nuts at this point. They should be finger-tight only. NOTE:** The flue edge will cover one to two inches of the lower insulation.
20. Install the lower rear combustion chamber back(s) and retainer(s) (7) with the flanged edge(s) against the flue. Secure with ¼"-20 washer nuts. **NOTE:** Full-vat units have two-piece backs and four retainers. Dual-vat units come with one-piece backs and only two retainers.
21. Insert the burners (9) into the rails to ensure the rail spacing and alignments are correct. The burner should slide freely into and out of the rails. The upper rail can be bent slightly to increase or decrease tension on the burner and the edges of the slot can be closed or opened slightly to best fit the burner frame.
22. Carefully wrap a strip of burner insulation (8) tightly around the rear and sides of the burner frame (9), with the glass-tape side of the strip on the outside. **Do not use duct tape or adhesive to secure the strip to the burner frame.**
23. Align the burner to the burner rails while maintaining tension on the insulation strip. Insert the burner at a slight angle and begin pushing the burner slowly into the rails until it contacts the rear combustion chamber. The fit should be snug, but not excessively tight.
24. Verify that the burners are flush with the front edge of the burner rails. Remove the excess burner insulation by cutting with a knife or diagonal pliers. **Do not try to tear the insulation!**
25. Insert the upper front insulation (10) into its retainer (11), making sure that the holes in each piece are aligned with one another. Install the assembly with the insulation side toward the frypot and secure with ¼"-20 washer-nuts. **Do not over tighten.**
26. Place a washer on each of the four lower studs on the front of the frypot. Install the lower inner front insulation (12) with the rectangular openings toward the drain valve nipple. Install the lower inner front insulation retainer(s) (13). **NOTE:** Full-vat units have a two-piece insulation retainer. Dual-vat units have a one-piece retainer.
27. If necessary, replace the sight-glasses and insulation (14).
28. Place one washer and one 1.888-inch spacer (15) on each stud. **NOTE:** There are three different sizes of spacers. Verify the size to ensure the correct spacers are installed.
29. Insert the front lower insulation (16) into the front lower insulation retainer(s) (17) and install assembly on frypot. Secure with ¼"-20 washer-nuts. If frypot uses two retainers, connect them together with two ¼" self-tapping screws. **NOTE:** Full-vat units have a two-piece insulation retainer and two pieces of insulation. Dual-vat units have one-piece components.
30. Return to the rear of the frypot and fully tighten all washer-nuts.
31. Remove and replace the plenum gaskets (18).
32. Place a 0.938-inch spacer (19) on the plenum-mounting studs, and mount the plenum (20). Ensure the gaskets are clear of the burner tubes by pulling the plenum back slightly. Place a washer on each stud and secure plenum with ¼"-20 lock-nuts.
33. Install the upper oil-zone insulation (21) by pressing it under the upper combustion chamber metalwork. Secure the insulation with the bracket (22) and ¼" self-tapping screws.
34. Install the upper burner rail blanket insulation (23). Position any excess insulation toward the top of the frypot. Avoid overhang past the bottom of the upper burner rail. Overhang in this area will make future burner replacement more difficult.
35. Cover the insulation with the insulation retainer (24), and secure with ¼" self-tapping screws.
36. Reinstall probes, drain valves, AIF boards, actuators, high-limit thermostats, and other pipe fittings using Loctite® PST56765 sealant or equivalent on the threads.

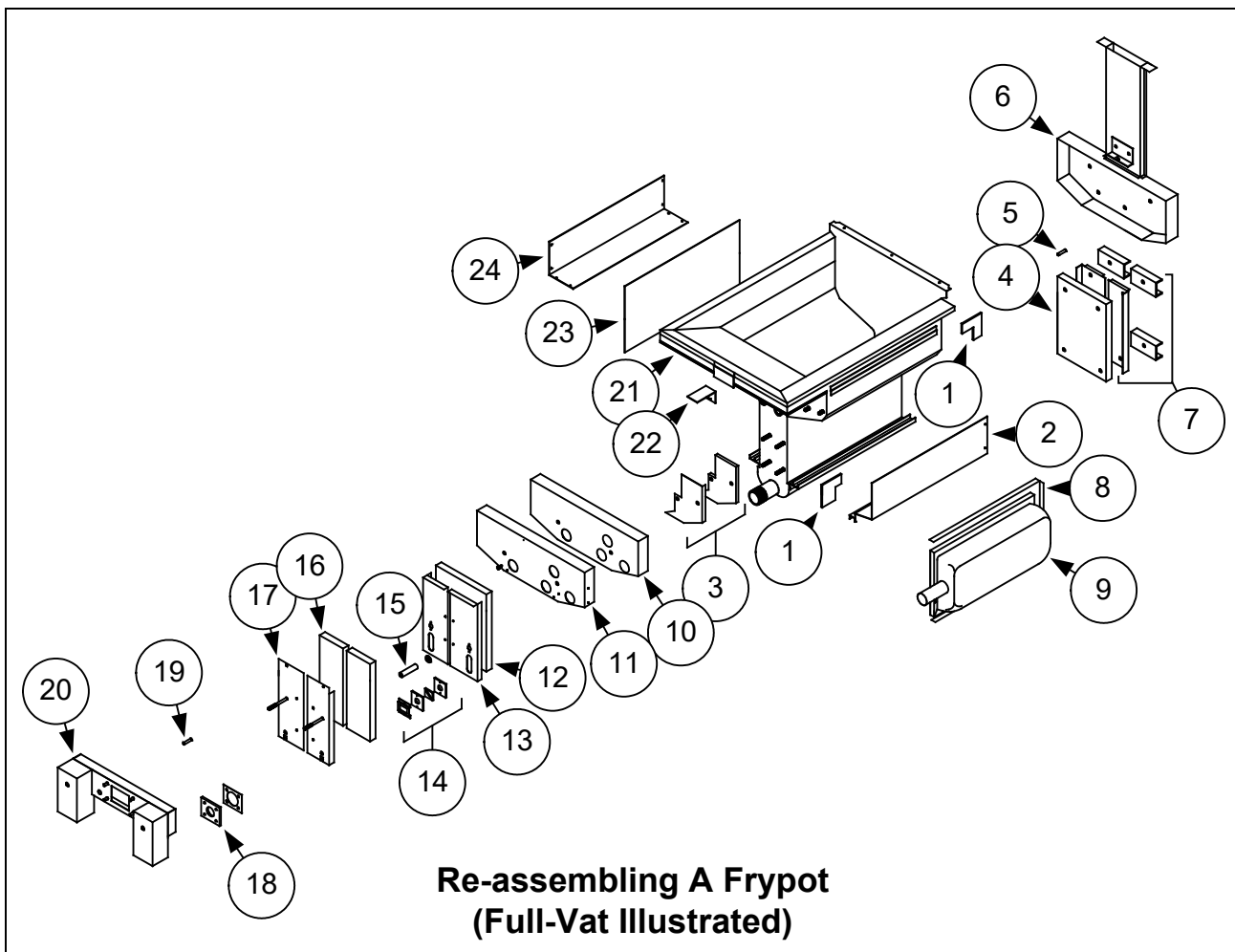

1.10 Troubleshooting and Problem Isolation

Because it is not feasible to attempt to include in this manual every conceivable problem or trouble condition that might be encountered, this section is intended to provide technicians with a general knowledge of the broad problem categories associated with this equipment, and the probable causes of each. With this knowledge, the technician should be able to isolate and correct any problem encountered.

Problems you are likely to encounter can be grouped into six categories:

1. Ignition failure
2. Improper burner function
3. Improper temperature control
4. Controller malfunctions
5. Filtration malfunctions
6. Leakage

The probable causes of each category are discussed in the following sections. A series of Troubleshooting Guides is also included at the end of the chapter to assist in solving some of the more common problems.

1.10.1 Heating (Ignition) Failure

Heating (ignition) failure occurs when the ignition module fails to sense a flame within the 4-second time delay period and locks out. When this happens, the module sends 24 VAC through the interface board alarm circuit to the controller.

FilterQuick™ controllers display “**HEATING FAILURE.**”

The three primary reasons for heating failure, listed in order of probability, are problems related to:

1. Gas and/or electrical power supplies
2. Electronic circuits
3. Gas valve.

PROBLEMS RELATED TO THE GAS AND/OR ELECTRICAL POWER SUPPLIES

The main indicators of this are that an entire battery of fryers fails to light and/or there are no indicator lights illuminated on the fryer experiencing heating failure. Verify that the quick disconnect fitting is properly connected, the fryer is plugged in with connector twisted and locked, the main gas supply valve is open, and the circuit breaker for the fryer electrical supply is not tripped.

PROBLEMS RELATED TO THE ELECTRONIC CIRCUITS

If gas and electrical power are being supplied to the fryer, the next most likely cause of heating failure is a problem in the 24 VAC circuit. Verify that the oil level sensor is working properly. Refer to Section 1.11.1, **TROUBLESHOOTING THE 24 VAC CIRCUIT.**

Some typical causes of heating failure in this category include a defective sensing wire in the ignitor assembly, a defective module, a defective ignition wire, and a defective ignitor.

Occasionally, a heating failure situation occurs in which all components appear to be serviceable and the microamp reading is within specification, but the unit nevertheless goes into heating failure during operation. The probable cause in this case is an intermittent failure of an ignition module. When the unit is opened up for troubleshooting, the module cools down enough to operate correctly; however, when the unit is again closed up and placed back into service the module heats up and fails.

PROBLEMS RELATED TO THE GAS VALVE

If the problem is not in the 24 VAC circuit, it is most likely in the gas valve, itself. Before replacing the gas valve, refer to Section 1.11.2 **TROUBLESHOOTING THE GAS VALVE.**

1.10.2 Improper Burner Function

With problems in this category, the burner ignites but exhibits abnormal characteristics such as “popping,” dark spots on the burner ceramics, fluctuating flame intensity, and flames shooting out of the flue.

“**Popping**” indicates delayed ignition. In this condition, the main gas valve is opening but the burner is not immediately lighting. When ignition does take place, the excess gas “explodes” into flame, rather than smoothly igniting.

The primary causes of popping are:

- Incorrect or fluctuating gas pressure
- Defective or incorrectly adjusted combustion air blower
- Inadequate make-up air
- Heat-damaged controller or ignition module
- Cracked ignitor or broken ignition wire
- Defective ignition module
- Cracked burner tile (typically causes a very loud pop).

If popping occurs only during peak operating hours, the problem may be incorrect or fluctuating gas pressure. Verify that the incoming gas pressure (pressure to the gas valve) is in accordance with the appropriate CE or Non-CE Standard found in Section 2.3 page 2-4 of the FilterQuick™ FQG30 Series Gas Fryer Installation and Operation Manual (PN 819-7052), and that the pressure remains constant throughout all hours of usage. Refer to Section 1.7, **Checking the Burner Manifold Gas Pressure** in this manual for the procedure for checking the pressure of gas supplied to the burner.

If popping is consistent during all hours of operation, the most likely cause is an insufficient air supply. Check for “negative pressure” conditions in the kitchen area. If air is flowing into the kitchen area, this indicates that more air is being exhausted than is being replenished and the burners may be starved for air.

If the fryer’s gas and air supplies are correct, the problem is most likely with one of the electrical components. Examine the ignition module and controller for signs of melting, distortion, and/or discoloration due to excessive heat build-up in the fryer (this condition usually indicates improper flue performance). A melted or distorted ignition module is automatically suspect and should be replaced; however, unless the condition causing excessive heat is corrected, the problem is likely to recur.

Verify that the ignition wire is tightly connected at both ends and free of obvious signs of damage. Again, if damage is due to excessive heat in the fryer, that problem must also be corrected. Check for proper operation by disconnecting the wire from the ignitor (spark plug), inserting the tip of a screw driver into the terminal. With the insulated handle of the screwdriver, hold the shaft near the frame of the fryer as the power switch is placed in the ON position. A strong, blue spark should be generated for at least four seconds.

 **DANGER**

Make sure you are holding the insulated handle of the screwdriver and not the blade. The sparking charge is approximately 25,000 volts.

Examine the ignitor (spark plug) for any signs of cracking. A cracked ignitor must be replaced.

If all other causes have been ruled out, examine the burner tiles for any signs of cracking. If cracking is found, the burner must be replaced.

Fluctuating flame intensity is normally caused by either improper or fluctuating incoming gas pressure, but may also be the result of variations in the kitchen atmosphere. Verify incoming gas pressure in the same way as for “popping,” discussed in the preceding paragraphs. Variations in the kitchen atmosphere are usually caused by air conditioning and/or ventilation units starting and stopping during the day. As they start and stop, the pressure in the kitchen may change from positive or neutral to negative, or vice versa. They may also cause changes in airflow patterns that may affect flame intensity.

Dark spots on the burner tiles are the result of an improper air/gas mixture. Adjust the combustion air blower to reduce the amount of air in the mixture to correct this problem.

Flames shooting out of the flue are usually an indication of negative pressure in the kitchen. Air is being sucked out of the burner enclosure and the flames are literally following the air. If negative pressure is not the cause, check for high burner manifold gas pressure in accordance with the procedures in Section 1.7.

An **excessively noisy burner**, especially with **flames visible above the flue opening**, may indicate that the gas pressure is too high, or it may simply be that the gas valve vent tube is blocked. If the incoming gas pressure is correct and the vent tube is unobstructed, the gas valve regulator is probably defective.

Occasionally a burner may apparently be operating correctly, but nevertheless the fryer has a **slow recovery rate** (the length of time required for the fryer to increase the oil temperature from 250°F to 300°F (121°C to 149°C)). The primary causes of this include an over-filled frypot, a dirty or out-of-adjustment combustion air blower, low burner manifold pressure, and/or damaged burner tiles. Adding oil to the frypot during the recovery process will also cause a slow recovery rate.

If these causes are ruled out, the probable cause is a misadjusted gas valve regulator. Refer to Section 1.7, **Checking the Burner Manifold Gas Pressure**, for the gas valve adjustment procedure.

1.10.3 Improper Temperature Control

Temperature control, including the melt cycle, is a function of several interrelated components, each of which must operate correctly. The principle component is the temperature probe. Other components include the interface board, the controller itself, and the ignition module.

Improper temperature control problems can be categorized into melt cycle problems and failure to control at setpoint problems.

MELT CYCLE PROBLEMS

Initiation of the melt cycle with FilterQuick™ controllers is automatic. Problems may originate from the controller itself, the temperature probe, or a malfunctioning heat relay on the interface board.

FAILURE TO CONTROL AT SETPOINT

Problems in this category may be caused by the temperature probe, the interface board, or the controller.

1.10.4 Controller Malfunctions

RECOVERY TIME

Recovery time – is a method of measuring a fryer’s performance. Put simply, it is the time required for the fryer to increase the oil temperature from 250°F to 300°F (121°C to 149°C). This range is used as a standard since ambient kitchen temperatures can affect the test if lower ranges are used.

The FilterQuick™ controller performs the recovery test each time the fryer warms up. An operator can view the results of the test any time the fryer is above the 300°F (149°C) point by pressing the check button once when the fryer is on. The test results will be displayed in the controller’s LED panel in minutes and seconds. The maximum acceptable recovery time for FilterQuick™ FQG30 Series gas fryers is two minutes and twenty-five seconds.

1.10.5 Filtration Malfunctions

The majority of filtration problems arise from operator error. One of the most common errors is placing the filter paper/pad on the bottom of the filter pan rather than over the filter screen.

Whenever the complaint is “the pump is running, but no oil is being filtered,” check the installation of the filter paper/pad, including that the correct size is being used. While you are checking the filter paper/pad, verify that the O-rings on the filter pan suction tube are present and in good condition. Missing or worn O-rings will allow the pump to suck air and decrease its efficiency.

If the pump motor overheats, its thermal overload will trip and the motor will not start until it is reset. If the pump motor does not start, press the red reset switch located on the front of the motor. If the pump then starts, something caused the motor to overheat. It may be just that several frypots in a large battery of fryers were being filtered one after the other and the pump became hot. Letting the pump cool down for at least a half-hour is all that is required in this case. More often, the pump overheated for one of the following reasons:

- Shortening that remained in the pan after previous filtering solidified in the suction tube recess in the bottom of the pan or the suction tube, itself. Adding hot oil to the pan and waiting a few minutes will usually correct this problem. A flexible wire can be used to clean out the suction tube and the recess in the bottom of the pan. **NEVER** use compressed air to blow solidified shortening out of the suction tube!
- The operator attempted to filter oil that was not heated. Cold oil is thicker and causes the pump motor to work harder and overheat.

If the motor hums but the pump does not rotate, there is a blockage in the pump. Incorrectly sized or installed paper will allow food particles and sediment to pass through the filter pan and into the pump. When sediment enters the pump, the gears can bind up and cause the motor to overload, tripping the thermal overload. Solidified shortening in the pump will also cause it to seize, with similar results.

A pump seized by debris or hard shortening can usually be freed by manually moving the gears with a screwdriver or other instrument as illustrated on the following page. **Make sure power to the pump motor is off before trying this.**

1. Disconnect power to the filter system.
2. Remove the input plumbing from the pump.
3. Use a screwdriver to manually turn the gears.
 - Turning the pump gears backwards will release a hard particle and allow its removal.

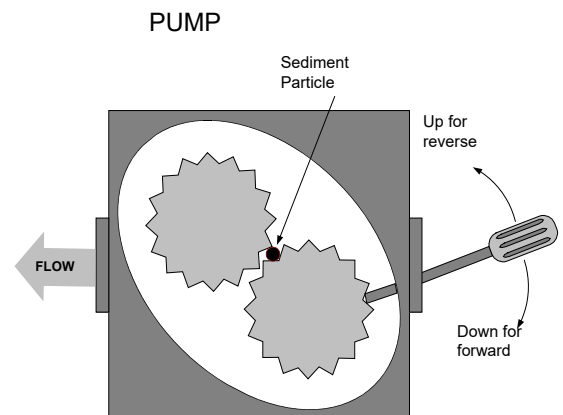

- Turning the pump gears forward will push softer objects and solid shortening through the pump and allow free movement of the gears.

Filter paper/pads that are installed incorrectly will also allow food particles and sediment to pass through and clog the suction tube recess on the bottom of the filter pan or the suction tube, itself. Particles large enough to block the suction tube recess or the suction tube may indicate that the crumb tray is not being used.

1.10.6 Leakage

Leakage of the frypot will usually be due to improperly sealed high-limit thermostats, RTD's, temperature probes, and drain fittings. When installed or replaced, each of these components must be sealed with Loctite® PST56765 sealant or equivalent to prevent leakage. In very rare cases, a leak may develop along one of the welded edges of the frypot. When this occurs, the frypot must be replaced.

If the sides or ends of the frypot are coated with oil, the most likely cause is spillage over the top of the frypot rather than leakage.

The clamps on the rubber boots that hold the drain tube sections together may loosen over time as the tubes expand and contract with heating and cooling during use. Also, the boot itself may be damaged. If the section of drain tube connected to the drain valve is removed for any reason, ensure that its rubber and clamps are in good condition and properly fitted around the drain tube when it is reinstalled. Also, check to ensure that the drain tube runs downward from the drain along its whole length and has no low points where oil may accumulate.

1.11 Troubleshooting Guides

The troubleshooting guides on the following pages are intended to assist service technicians in quickly isolating the probable causes of equipment malfunctions by following a logical, systematic process. An additional set of operator troubleshooting guides are contained in Chapter 6 of the FilterQuick™ FQG30 Series Installation and Operation Manual. It is suggested that service technicians thoroughly familiarize themselves with both sets.

1.11.1 Troubleshooting the 24 VAC Circuit

Prior to checking for problems associated with the 24 VAC circuit, ensure that the unit is connected to a power supply, the drain valve is fully closed, and the controller is on and is calling for heat (green dot appears under heat indicator and displays **LOW TEMP** alternating with the vat temperature).

NOTE: All voltage measurements must be made within **4 seconds** of the unit calling for heat. If unit does not fire within **4 seconds**, ignition modules will lock out and controller must be turned off, then on to reset.

The following processes will assist you in troubleshooting the 24 VAC circuit and ruling it out as a probable cause:

- **24 VAC is not present on the interface board J3 pin 9 (LED 5 (GV)) and, on dual units, on J1 pin 9 (LED 1 (GV)).**
 1. If LED 3 *is not* continually lit, the probable causes are a failed 24 VAC transformer or failed wiring between the transformer and interface board.
 2. If LED 3 *is* continually lit, check the right PWR terminal (LED 4) for 24 VAC. On dual units, also check the left PWR terminal (LED 2) for 24 VAC. Verify that the F2 fuse is not blown.
 - a. If 24 VAC *is not* present, the probable cause is a failed interface board, blown fuse or a defective heat relay.
 - b. If 24 VAC *is* present, check for 24 VAC on V1S (or V1D and V2D).
 - i. If 24 VAC *is not* present, check the fuses. If they are good, the probable causes are failed ignition module(s) or a failed interface board. Replace the questionable ignition module with one known to be good to isolate the cause.
 - ii. If 24 VAC *is* present, the probable cause is a failed interface board.
- **24 VAC is present on interface board J3 pin 9 (LED 5 (GV)) and, on dual units, on J1 pin 9 (LED 1 (GV)).**
 1. If 24 VAC *is not* present across the gas valve main coil (MV terminals), probable causes are an open high-limit thermostat or a failed wire between the interface board and gas valve. Be sure to check both valves on dual units.
 - a. Check continuity of high-limit thermostat. If it is zero, problem is in wiring.

- If 24 VAC is present across the gas valve main coil (MV terminals), the 24 VAC circuit is working and the problem may be with the gas valve. Be sure to check both valves on dual vat units.

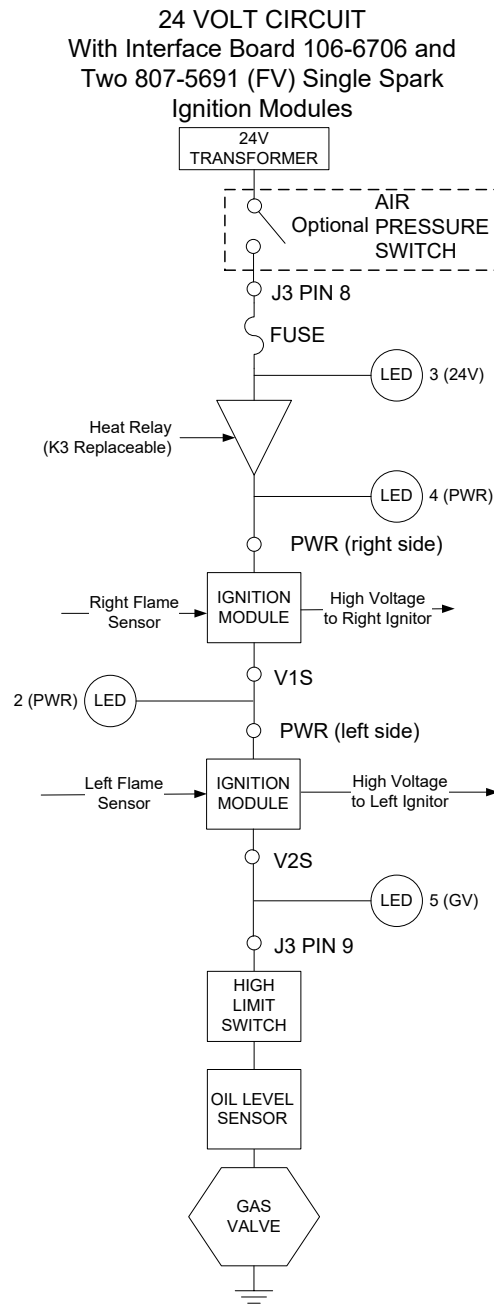

24 VOLT CIRCUIT
 With Interface Board 106-6706 and
 Two 807-5691 (DV) Single Spark Ignition Modules

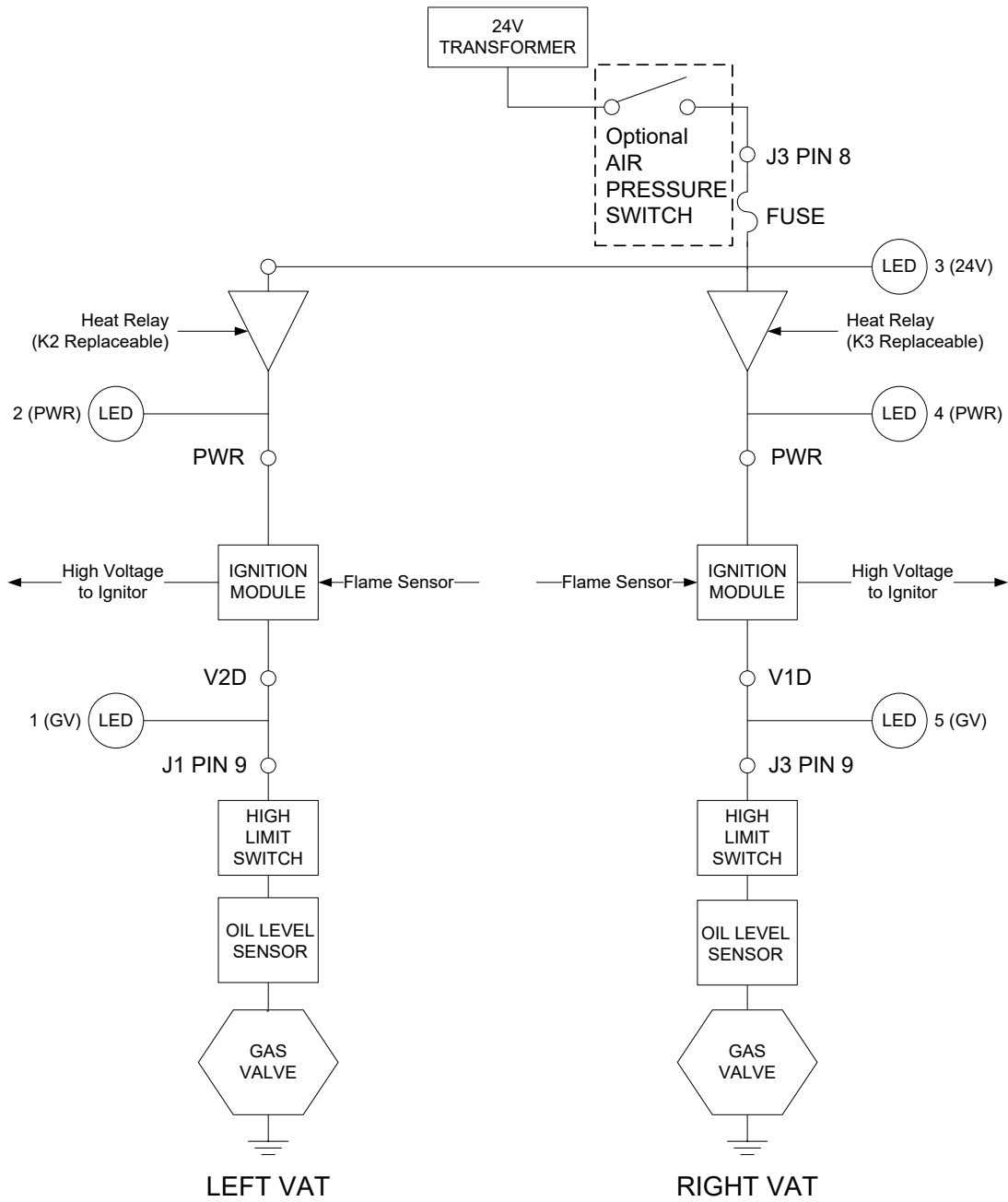

1.11.2 Troubleshooting the Gas Valve

Prior to checking for problems associated with the gas valve, ensure that the unit is calling for heat. Also, for non-CE units, verify that the gas valve is in the ON position.

The following processes will assist you in troubleshooting the gas valve and ruling it out as a probable cause:

- If 24 VAC is not present across gas valve main coil, the probable cause is the 24 VAC circuit. Refer to the 24 VAC circuit troubleshooting guide.

- If 24 VAC is present across gas valve main coil, check the incoming gas pressure and compare to the tables on page 2-4 of the Installation and Operation manual.
 1. If incoming gas pressure *is not* correct, the probable cause is a problem with the gas supply to fryer.
 2. If incoming gas pressure *is* correct, check the burner manifold gas pressure and compare it to the tables on page 2-7 of the Installation and Operation manual.
 - a. If burner manifold gas pressure *is not* correct, the probable cause is an improperly adjusted or failed gas valve. Adjust the valve by following the procedure “Check Burner Manifold Pressure” in Section 1.4 of this manual. If the valve cannot be adjusted, replace it.
 - b. If outgoing gas pressure *is* correct, the gas valve is okay.

1.11.3 Troubleshooting the Temperature Probe

⚠ CAUTION

Disconnect the FILTERQUICK™ controller before testing temperature probe resistances to avoid invalid readings

Prior to checking for problems associated with the temperature probe, inspect the probe body for damage while it is still in the frypot. Remove and replace the probe if it is bent, dented, or cracked. Also, inspect leads for fraying, burning, breaks, and/or kinks. If found, replace the probe.

The following processes will assist you in troubleshooting the gas valve and ruling it out as a probable cause:

Before testing the probe, determine the temperature the cooking oil using another thermometer or pyrometer placed at the tip of the questionable probe.

- If resistance through J3 pins 2 and 6 (J1 pins 2 and 6 for left side of dual unit) is not approximately equal to that given in the Probe Resistance Chart for the corresponding temperature, the probe has failed and must be replaced.
- If resistance through J3 pins 2 and 6 (J1 pins 2 and 6 for left side of dual unit) is approximately equal to that given in the Probe Resistance Chart for the corresponding temperature, measure the resistance through each of the previously tested pins to ground.
 1. If resistance *is not* 5 mega-Ohms or greater in each pin, the probe has failed and must be replaced.
 2. If resistance *is* 5 mega-Ohms or greater in each pin, the probe is okay.

1.11.4 Replacing the Transformer or Filter, or Reset Switch Relay

Disconnect the fryer from the electrical power supply. Remove the cover from the transformer box in the rear of the fryer to expose the interior of the transformer box (see photo below). Replace the transformer or filter relay marking the wires to ease reassembly. Once replaced, reconnect the power. When replacing a filter relay in the transformer, ensure the 24VDC relay (8074482) is used.

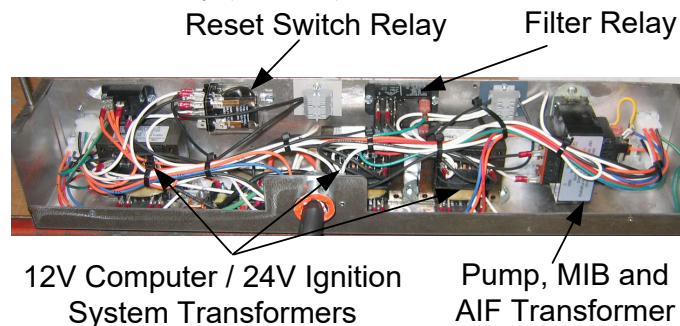

1.12 Basket Lift Service Procedures

FQG30™ series gas fryers may be equipped with automatic basket lifts. Basket lifts always come in pairs, although each operates independently.

A **modular basket lift** (illustrated on the following page) is a self-contained sub-assembly consisting of a pair of toothed rods, which support removable basket lift arms, a pair of reversible-drive gear motors, and four microswitches. The gear motors engage the teeth of the rods, moving them up or down depending upon the motors' direction of rotation. The microswitches at the upper and lower limits of movement stop the motors when the basket is in the full up or full down position.

Timing circuitry in the controller initiates and stops basket lift operation depending upon the variables programmed by the operator. When the product button is pressed, the timing circuitry activates a coil in the basket lift relay to supply power to the lower microswitch. The microswitches stop the motor at the lift's upper and lower travel limits and reverse the direction of current flow thus reversing the motor direction.

When the product button is pushed on the controller, current flows through a coil in the basket lift relay, causing the lower circuit to be activated. The basket lift lowers, closing the normally open upper-micro-switch. When the downward-moving rod opens the lower normally closed microswitch, the power to the motor ceases to flow. When the controller times out, the current to the relay coil is cut, allowing the upper circuit to be activated. The basket lift rises and re-closes the lower microswitch. When the basket lift rod clears the upper microswitch, the microswitch reopens, power to the circuit is cut, and the motor stops. Pushing the product button restarts the cycle.

Problems with the basket lift can be grouped into three categories:

- Binding/jamming problems
- Motor and gear problems
- Electronic problems

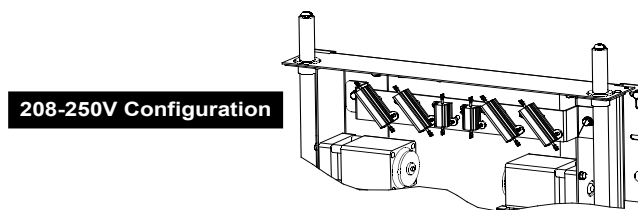
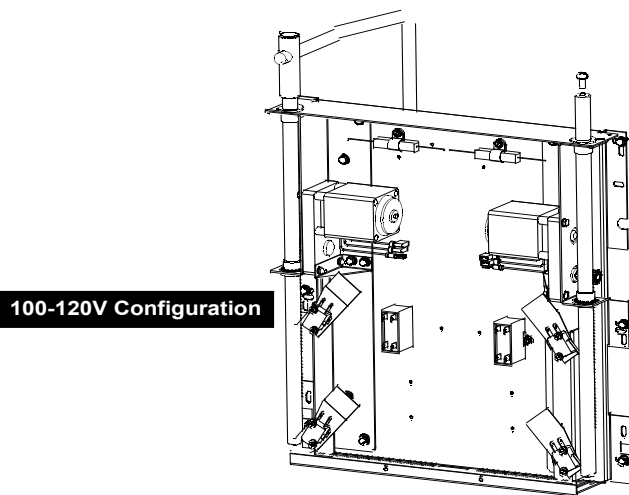

Binding and Jamming Issues

Noisy, jerky or erratic movement of the lifts is usually due to lack of lubrication of the rods and their bushings. Apply a light coat of Lubriplate® or similar lightweight white grease to the rod and bushings to correct the problem.

With the modular basket lift, another possible cause of binding is improper positioning of the motor, which prevents the gear from correctly engaging the teeth in the rod. To correct the problem, loosen the screws that hold the motor in place and move it forward or backward until the rod has just enough slack to be rotated slightly.

Motor and Gear Issues

With the modular basket lift, the most likely problem to be encountered in this category is erratic motion of the lift due to a worn drive gear. Failure to keep the lift rod and bushings properly lubricated will cause unnecessary wear of the gear. The problem is corrected by replacing the worn gear.

If the lift cycles correctly but fails to remain in the up position (i.e., goes up, but then slowly settles back down into the frypot), the problem is a failed motor brake. A failed motor brake cannot be repaired and requires replacement of the motor itself.

If power is reaching the motor but the motor fails to run, the motor is burned out and must be replaced.

Electronic Issues

Within this category are problems associated with the relays, microswitches, capacitors, resistors, interface board, wiring, and controls. The most common problem in this category is a lift that continuously travels up and down. This is usually caused by a microswitch that is out of adjustment. Troubleshooting the electronics of a modular basket lift is simply a process of verifying current flow through the individual components up to and including the motor. Using a multimeter set to the 250 VAC range, check the connections on both sides of the component for the presence of the applied line voltage. The schematic below and the wiring diagram on page 1-70 and 1-71 can identify the components and wiring connection points.

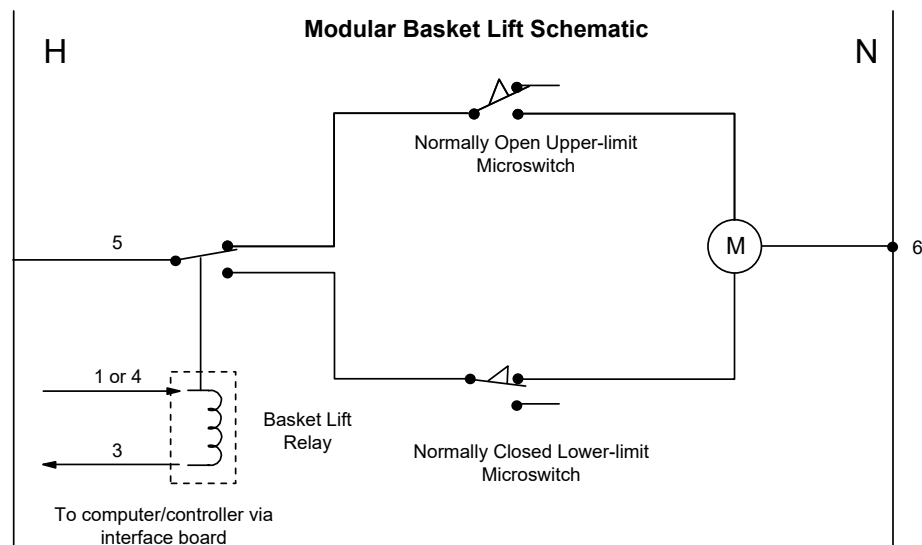

1.13 Probe Resistance Chart

<h2 style="text-align: center;">Probe Resistance Chart</h2> <p style="text-align: center;"><i>For use with FilterQuick™ Series fryers manufactured with Minco Thermistor probes only.</i></p>																	
F	OHMS	C	F	OHMS	C	F	OHMS	C	F	OHMS	C	F	OHMS	C			
60	1059	16	130	1204	54	200	1350	93	270	1493	132	340	1634	171			
65	1070	18	135	1216	57	205	1361	96	275	1503	135	345	1644	174			
70	1080	21	140	1226	60	210	1371	99	280	1514	138	350	1654	177			
75	1091	24	145	1237	63	215	1381	102	285	1524	141	355	1664	179			
80	1101	27	150	1247	66	220	1391	104	290	1534	143	360	1674	182			
85	1112	29	155	1258	68	225	1402	107	295	1544	146	365	1684	185			
90	1122	32	160	1268	71	230	1412	110	300	1554	149	370	1694	188			
95	1133	35	165	1278	74	235	1422	113	305	1564	152	375	1704	191			
100	1143	38	170	1289	77	240	1432	116	310	1574	154	380	1714	193			
105	1154	41	175	1299	79	245	1442	118	315	1584	157	385	1724	196			
110	1164	43	180	1309	82	250	1453	121	320	1594	160	390	1734	199			
115	1174	46	185	1320	85	255	1463	124	325	1604	163	395	1744	202			
120	1185	49	190	1330	88	260	1473	127	330	1614	166	400	1754	204			
125	1195	52	195	1340	91	265	1483	129	335	1624	168	405	1764	207			

1.14 ATO (Automatic Top-off) Service Procedures

The automatic top-off system is activated when the oil level falls below a sensor in the front of the frypot. The signal is sent to the ATO board to engage the return actuator to the frypot and turn on the ATO pump. The pump draws oil from the JIB (Jug In Box) through the rear return manifold into the rear of the frypot. Once the oil level has satisfied the sensor, the pump turns off and the actuator closes.

The ATO board is located inside the box, behind the JIB (see Figure 1). The power for the ATO board is supplied from the transformer box. The power passes through the transformer inside the ATO box to the board.

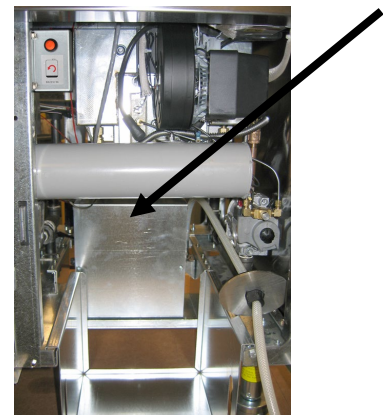

Figure 1

1.14.1 ATO (Automatic Top-Off) Troubleshooting

Problem	Probable Causes	Corrective Action
Fryer tops off cold.	Incorrect setpoint.	Ensure setpoint is correct.
No power to ATO board	A. J5 connection unplugged B. Fuse blown. C. Transformer malfunction	A. Check to ensure J5 on front of ATO board is fully locked into connector. B. Ensure fuse located on right side of ATO box is not blown. C. Check that proper voltage is present at transformer. See table in section 1.13.2.
One vat tops off but other vats fail to top off.	A. Loose wire connection. B. Actuator issue.	A. Ensure all wiring harnesses are securely connected to ATO board and solenoids. B. Check return actuator to ensure actuator is functional.

Problem	Probable Causes	Corrective Action
Frypots won't top off.	<ul style="list-style-type: none"> A. Empty JIB. B. Probe temperature lower than setpoint. C. Oil is too cold. D. Crumb build up around sensor. E. Bad Connection F. ATO board power loss G. Failed transformer/harness. H. ATO pump failed. I. Failed ATO board. J. ATO lines/pump plugged 	<ul style="list-style-type: none"> A. Ensure JIB has oil. B. Check to see that fryer is heating. Fryer temperature must be at setpoint. Check probe resistance. If probe is bad, replace the probe. C. Ensure that the oil in the JIB is above 70°F (21°C). D. Clean crumbs from opening surrounding sensor. E. With the controller OFF, press the temperature button and ensure the ATO software version appears. If not, the connection between the AIF and the ATO board may be bad. Ensure the 6-pin CAN connectors are tight between AIF (J4 and J5) and ATO (J9 or J10) boards. F. Power to the ATO board has been cut off. Restore power to the board and clear any service required errors. G. Ensure transformer in ATO box is functioning properly. Check power from transformer to ATO board. Ensure all harnesses are plugged securely into place. H. Ensure pump is operational. Check voltage to pump. Replace the pump if defective. I. Check for proper voltages using the pin position chart found on page 1-28. If ATO found defective, replace ATO board. J. Clear the lines/pump.
Incorrect vat tops off.	<ul style="list-style-type: none"> A. Wired incorrectly. B. Flexlines connected to wrong vat. 	<ul style="list-style-type: none"> A. Check wiring. B. Switch flexlines to correct vat.
One vat doesn't top off.	<ul style="list-style-type: none"> A. Filter error exists. B. Actuator, pump, loose connection, RTD or ATO issue. 	<ul style="list-style-type: none"> A. Clear filter error properly. When CHANGE FILTER PAPER YES/NO is displayed, do NOT press any button until the pan has been removed for at least thirty seconds. After thirty seconds the controller returns to OFF or last display. B. Check actuator, ATO pump, ATO board, wire connections and RTD.
Controller displays SERVICE REQUIRED – ATO BOARD	<ul style="list-style-type: none"> A. Loose or bad fuse B. Bad Connection C. ATO Board power loss 	<ul style="list-style-type: none"> A. Ensure fuse on right side of ATO box is secure and good. B. With the controller OFF, press the temperature button and ensure the ATO software version appears. If not, the connection between the AIF and the ATO board may be bad. Ensure the 6-pin CAN connectors are tight between AIF (J4 and J5) and ATO (J9 or J10) boards. C. Power to the ATO board has been cut off. Ensure there is correct voltage to the ATO transformer. Restore power to the board and clear any service required errors.

1.14.2 ATO (Automatic Top-Off) Board Pin Positions and Harnesses

Connector	From/To	Harness #	Pin #	Function	Voltage	Wire Color	
J8	Bulk Fresh Oil Solenoid	8074671	1	24VAC Ret	24VAC	Black	
			2				
			3				
	Top Off Pump Relay		4	24VAC Ret	24VAC	Black	
			5				
			6				
			7				
	JIB Reset Switch		8	JIB Low Reset	16VDC	Black	
	Bulk Fresh Oil Solenoid		9	24VAC	24VAC	Red	
			10				
			11				
	Top Off Pump Relay		12	24VAC	24VAC	Red	
			13				
			14				
	JIB Reset Switch		15				
	16	Ground	16VDC	Red			
J4 (Rear) / J5 (Front)	Transformer	8074553	1	24VAC Ret	24VAC	Orange	
			2	24VAC		Blue	
			3				
			4				
			5	12VAC Ret	12VAC	Red	
			6	12VAC		Brown	
	ATO 4 & 5 Battery Jumper		8074657	7	Jumper	Ohm	Black
				8	Jumper		Black
J1 - Vat #1 J2 - Vat #2 J3 - Vat #3	ATO RTD	8262569- Probe Kit, 8074845 – 28” Ext., 8074655 – 20” Ext.,	1	DV - Probe Ground	Ohm	White	
			2	DV - Probe		Red	
			3	FV - Probe Ground		White	
			4	FV - Probe		Red	
J6							
J10	Network Resistor (pins 2 & 3) or to next ATO Board (4 & 5 vat units)	8074552 (Network resistor), 8074546 to next ATO board	1	Ground		Black	
			2	CAN Lo		Red	
			3	CAN Hi		White	
			4	5VDC+	5VDC	Black	
			5	24VDC	24VDC	Red	
			6	Ground		White	
J9	AIF J5	8074547	1	Ground		Black	
			2	CAN Lo		Red	
			3	CAN Hi		White	
			4	5VDC+	5VDC	Black	
			5	24VDC	24VDC	Red	
			6	Ground		White	

1.14.3 Replacing the ATO Board, ATO Pump Relay or Transformer

Disconnect the fryer from the electrical power supply. Locate the ATO box (see Figure 1 on page 1-26), behind the JIB (Jug In Box). Remove the cover to expose the transformers and relay (see Figure 2). Mark and unplug any wires or harnesses. Replace the defective component and reattach all wires or harnesses. Replace the cover. Once replaced, **CYCLE POWER TO ENTIRE FRYER SYSTEM.** See section 1.15.6 to reset control power. Check software version and if necessary update the software. If a software update is necessary, follow the instructions to update the software in section 1.19.



Figure 2

Press the temperature button on one of the FilterQuick™ controllers with the controller in the OFF position to verify software version of the ATO. If the ATO version is not visible, the ATO may not be connected properly.

1.14.4 Replacing the ATO Pump or Solenoid

Disconnect the fryer from the electrical power supply. Locate the ATO pump (see Figure 4), behind the ATO box. Mark and unplug any wires or harnesses. Press up from the bottom on the quick disconnects to release the plumbing (see Figure 5). The plumbing can be pulled from the pump. Loosen the four nuts attaching the pump to the pump tray. Replace the defective component and reverse above steps. Once replaced, reconnect the power.



Figure 4



Figure 5

1.15 MIB (Manual Interface Board) Service Procedures

The MIB (Manual Interface Board) oversees and controls filtration. It receives and sends data over the CAN (Controller Area Network) to and from various sensors and controllers. It activates the filtration cycle, controlling when actuators should open and close.

The MIB controller is located inside the left cabinet (see Figure 6). In normal operation a cover hides the MIB controls and only the LED display is visible. The cover is held in place with a T-25 torx screw. In normal operation, an “A” is displayed for automatic mode. The MIB control board is useful for diagnostic purposes. It allows manual operation of both the actuators and filter pump without using the FilterQuick™ controller.

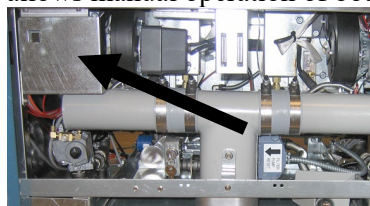

Figure 6: MIB controller cover.

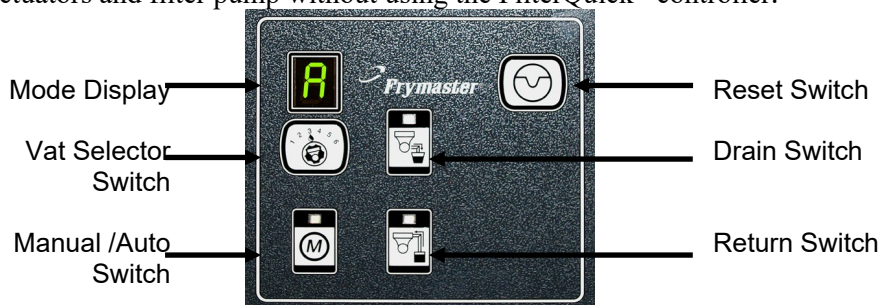

Figure 7

Buttons and LED's

Manual – This button is used to toggle between auto and manual filtration mode. A corresponding LED is lit when in Manual mode. When pressed, a message will be sent to all vats, indicating the mode has changed.

The following buttons are inoperable in auto mode:

Select - This button is used to scroll through available vats, choosing one to be manually filtered.

Drain – This button is used to open and close the drain on the vat indicated on the display. It's embedded LED indicates the following activity:

Blink: Actuator is moving or awaiting a response from the AIF board, or an error conditions exists.

Constant Illumination: Drain open.

No Illumination: Drain closed.

Return – This button is used to open and close the return valve on the vat indicated on the display. When pressed and held, it also turns on and off the pump. It's embedded LED indicates the following activity:

Blink: Actuator is moving or awaiting a response from the AIF board, or an error condition exists.

Constant Illumination: Return valve open.

No Illumination: Return valve closed.

The pump is turned off first before closing the return valve or the valve will open first before turning on the pump.

1.15.1 Manually Draining, Refilling or Filtering using the MIB board

Press the manual/auto switch to set to manual. The LED on the manual key will illuminate and a vat number is displayed (see Figure 8).

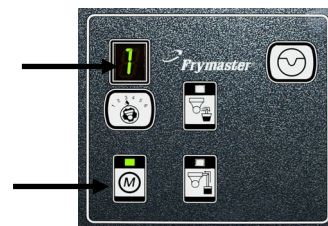

Figure 8

Press the vat selector switch to change vats (see Figure 9).

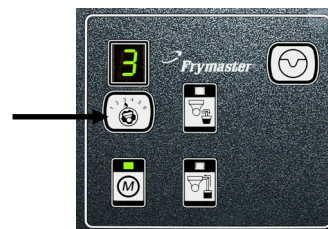

Figure 9

Pressing the drain or pressing the return switch illuminates and activates the drain or return valve for the vat indicated. Pressing and holding the return switch while the return is open activates the filter motor and pump (see Figure 10).

Pressing the manual/auto switch will return to automatic mode.

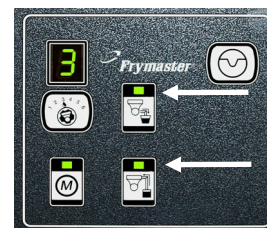

Figure 10

1.15.2 MIB (Manual Interface Board) Troubleshooting

Problem	Probable Causes	Corrective Action
Auto filtration won't start.	<ul style="list-style-type: none"> A. Filter pan out of position. B. Oil level too low. C. Ensure MIB board is not in manual mode. D. Ensure MIB cover is not damaged and pressing against buttons. E. Filter relay has failed. F. Filter motor thermal switch is tripped. 	<ul style="list-style-type: none"> A. Ensure filter pan is fully inserted into fryer. If the MIB board displays a “P” the pan is not fully engaged into the pan switch. B. Ensure the oil level is above the top oil level sensor. C. Ensure MIB board is in “A” automatic mode. D. Remove and replace cover and see if filtration will start. E. Replace filter relay with part number 807-4482 24VDC relay. F. Press filter motor thermal switch.
MIB display shows something other than an “A” or vat number.	An error has occurred and displayed character indicates error.	See MIB display characters on page 1-34 for explanation.
No power present at the MIB board	Transformer has failed in left component box.	Check output on the left transformer in left component box; should read 24VAC. If not replace transformer.
MIB will not clear error.	Error remains in non-volatile memory.	Press and hold reset button in top right corner of MIB board for five seconds. The drain, return and manual/auto LEDES will illuminate and the MIB will reset and clear any remaining errors from memory. Allow 60 seconds to reset. If an error still exists, then another issue exists.
MIB indicates incorrect number of vats.	<ul style="list-style-type: none"> A. Network is not terminated correctly. B. Wiring harnesses are loose or damaged. C. An AIF board issue. D. Locator pin issue. 	<ul style="list-style-type: none"> A. Ensure the CAN bus system is terminated at BOTH ENDS (on the FilterQuick™ controller connector J6 and on the ATO board connector J9) with a resistor equipped 6-pin connector. B. Unplug and reseat all wiring harnesses in CAN system. Resistance between pins 2 and 3 on the CAN network connectors should be 120 ohms. C. Check software version numbers on all FilterQuick™ controllers and ensure all display an AIF version. If an AIF version is missing, the AIF board may be missing power or bad. Check pins 5 and on J4 and J5 of the affected AIF board for proper voltage. D. The locator pin in J2 of the AIF board is either loose or in the incorrect position. See the charts on page 1-41 of this manual for proper pin position.

Problem	Probable Causes	Corrective Action
<p>MIB board alternating “E” and “vat number and side”.</p>	<p>Network error on the CAN bus communication.</p>	<p>A. Ensure the CAN bus system is terminated at BOTH ENDS (on the FilterQuick™ controller connector J6 and on the ATO board connector J10) with a resistor equipped 6-pin connector.</p> <p>B. With the controller OFF, press the temperature button and ensure the AIF version appears. If not, the 24V to the AIF boards may be missing. Ensure all 6-pin CAN connectors are tight between the FilterQuick™ controller (J6 and J7), MIB (J1 and J2), AIF (J4 and J5) and ATO (J10) boards.</p> <p>C. With the controller OFF, press the temperature button and ensure the ATO version appears. If not, check the CAN wire harness between the AIF board J4 or J5 and the ATO board J9 or J10. The ATO fuse on the right side of the ATO box may be loose or blown; the 110V to the ATO transformer may be missing or bad. The J4/J5 connector may be loose.</p> <p>D. Check to see if MIB has 24V on pins 5 and 6 of J2. Check to see if 24V is present on pins 5 and 6 of wire harness plugging into J4 or J5 of the first AIF board. If 24V missing, check the pins. Replace the harness if necessary.</p> <p>E. Check continuity between each color wire on the CAN connectors into J7 on the far right controller and J10 on back of the ATO board (black to black, white to white, and red to red), and ensure there is no continuity between different color wires (black to red, red to white, and white to black).</p> <p>F. Ensure black controller locator wires are connected from ground to correct pin position (see drawing 8051978 page 1-65).</p> <p>G. Ensure all boards have the corner ground wire attached and tightened.</p> <p>H. The locator pin in J2 of the AIF board is either loose or in the incorrect position. See the charts on page 1-41 of this manual for proper pin position.</p> <p>I. Bad MIB and/or AIF board.</p> <p>J. Broken resistor lead. Unwrap the resistor leads and check ends.</p>

1.15.3 MIB (Manual Interface Board) Pin Positions and Harnesses

Connector	From/To	Harness #	Pin #	Function	Voltage	Wire Color
J1	FilterQuick™ Controller/ J6	8074546	1	Ground		Black
			2	CAN Lo		Red
			3	CAN Hi		White
			4			
			5			
			6			
J2	AIF J5	8074850	1	Ground		Black
			2	CAN Lo		Red
			3	CAN Hi		White
			4	5VDC+	5VDC	Black
			5	24VDC	24VDC	Red
			6	Ground		White
J5	Transformer	8075800 Bulk 8075780 Non-Bulk	1	24VAC In	24VAC	Black
	Filter Relay		2	24VAC In Ret		White
				3	Pump Motor + Out	24VDC
	4			Pump Motor - Out	Green	
	Bulk Open Switch		5			
			6			
	Bulk Closed Switch		7	Open Switch +		Black
			8	Closed Switch +		Red
	Pan Switch		9			
			10			
			11	Pan Sw +	24VDC	Black
			12	Pan Sw -		Red
	Bulk Open Switch Bulk Closed Switch		13			
			14			
			15	Ground -		White
			16	Ground -		Green
J6	To Bulk connection in rear of fryer	8075789	1	From bulk oil transformer	24VAC	Black
			2	Common Return		White
			3	To bulk oil fresh oil pump relay	24VAC	Green
			4			
			5			
			6			
			7			
			8	From bulk oil "Waste Tank Full Sensor" Test Pins 2 to 8	24VAC – Full 0VAC – Not Full	Red

1.15.4 MIB (Manual Interface Board) Display Characters

A – Auto Mode – Auto Filtration enabled.

E – Drain or return valve is not in desired state. The display will alternate between **E** and the corresponding vat number. Ensure the actuator is plugged in and an error does not exist.



– Three horizontal lines indicate the AIF temperature sensor did not detect that the vat was full during auto filtration.

n – Network Error - An “**n**” displays for 10 seconds if no communication is received from the cooking controller within ten seconds after a power on or MIB reset.

P – Pan Switch – Filter pan is improperly seated. Filtration is suspended.

r – Reset Switch - Reset the vat closes all of the valves on the vat. If displayed for some time, there is probably a problem with the board.

1 – 5 – Numbers which correspond to the vats with either an “**L**” indicating the left side of a split vat or “**r**” indicating the right side of a split vat or a full vat. These numbers are displayed in manual mode.

1.15.5 Replacing the MIB Board

Disconnect the fryer from the electrical power supply. Remove the torx screw from the bottom of the MIB cover, exposing the MIB board (see Figure 11). Remove the two cabinet screws at the top (see Figure 12). Carefully hinge down the MIB board. Carefully remove the plugs on the rear of the board (see Figure 13). Replace with a new MIB board and reverse steps to reassemble. Once replaced, reconnect the power. Readdress the MIB board following the instructions in the next section. Once replaced, **CYCLE POWER TO ENTIRE FRYER SYSTEM**. See next section to reset control power. Check software version # and if necessary update the software. If a software update is necessary, follow the instructions to update the software in section 1.19.

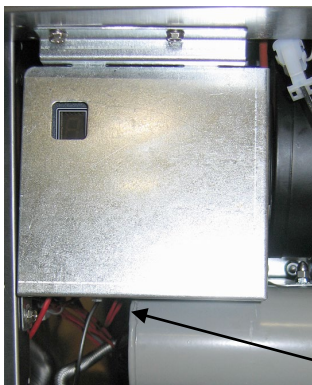

Figure 11

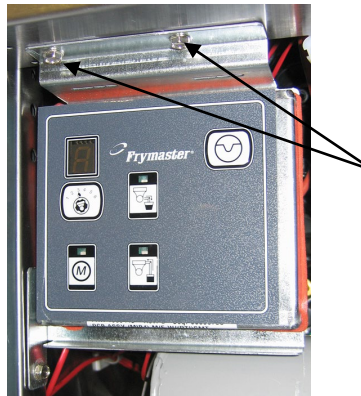

Figure 12

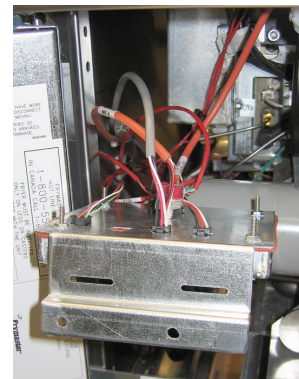

Figure 13

1.15.6 Control Power Reset Switch

The control power reset switch, is a momentary rocker switch located below the left control box (see Figures 14), that resets all power to all the controllers and boards in the fryer. It is necessary to reset all power after replacing any controller or board. Press and hold the switch for at least ten seconds when resetting the control power to ensure power has sufficiently drained from boards.

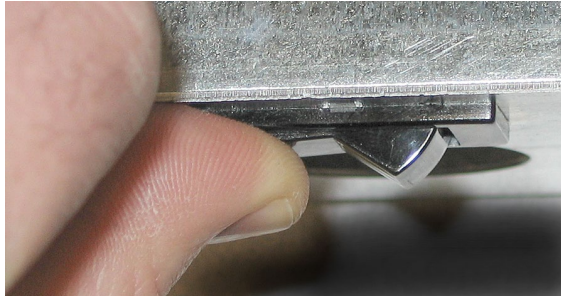

Figure 14

1.16 Bulk Oil Service Issues

1.16.1 Bulk MIB Tests

Bulk oil providers provide waste and/or fresh bulk oil services.

The FilterQuick™ fryer will ONLY operate with bulk oil systems that have a three-pole float switch. If the float switch is the older two-pole switch, call the bulk oil provider. These float switches are polarity specific which may short to ground and damage an MIB board.

Normal measurements (MIB J6 8-pin connector with everything connected)

AC voltage measurements:

Pin 1 to Pin 2 - 24 VAC.

Pin 2 to Pin 8 - 24 VAC when waste tank is full, 0 VAC when it is not full.

Pin 1 to Pin 3 - 24 VAC when bulk fresh oil add switch and pump is on, 0 VAC when it is off.

Using the Bulk test box, PN# 108-0716 allows a quick and easy way to check the 24VAC, the waste full switch and when the bulk fresh oil pump is operating.

Troubleshooting

All return and drain valves should be closed and pump should be off while the MIB is resetting. If any of the valves or the pump is on during reset, the MIB board is bad or wires are shorted.

Bulk fresh oil pump is not operating or JIB is not filling:

See page 1-38 to ensure that no other function is taking priority over adding oil to jug.

1. Reset the power; wait 60 seconds and see if the valve opens.

With the JIB button pressed:

2. Voltage at MIB board from Pin 1 to Pin 2 should be 24 VAC; if not, check connections from bulk fresh oil pump 24VAC transformer and check transformer.

3. Voltage at MIB board from Pin 1 to Pin 3 should be 24 VAC when filling JIB or vat; if not, the MIB board is bad or wires to pump relay are shorted or both.

4. Voltage at Add pump relay should be 24 VAC; if not, check wiring from MIB board. The relay should be located at the fresh oil tank pump system.

5. Check voltage at ATO board on J8. Pin 9 to Pin 1 should be 24 VAC with the orange button pressed.

Waste full signal:

Pin 2 to Pin 8 should be 24 VAC when full, 0 VAC when not full; if no voltage level change, the connection from bulk waste oil switch or MIB board is bad.

1.16.2 Bulk Wiring

BULK OIL WIRING

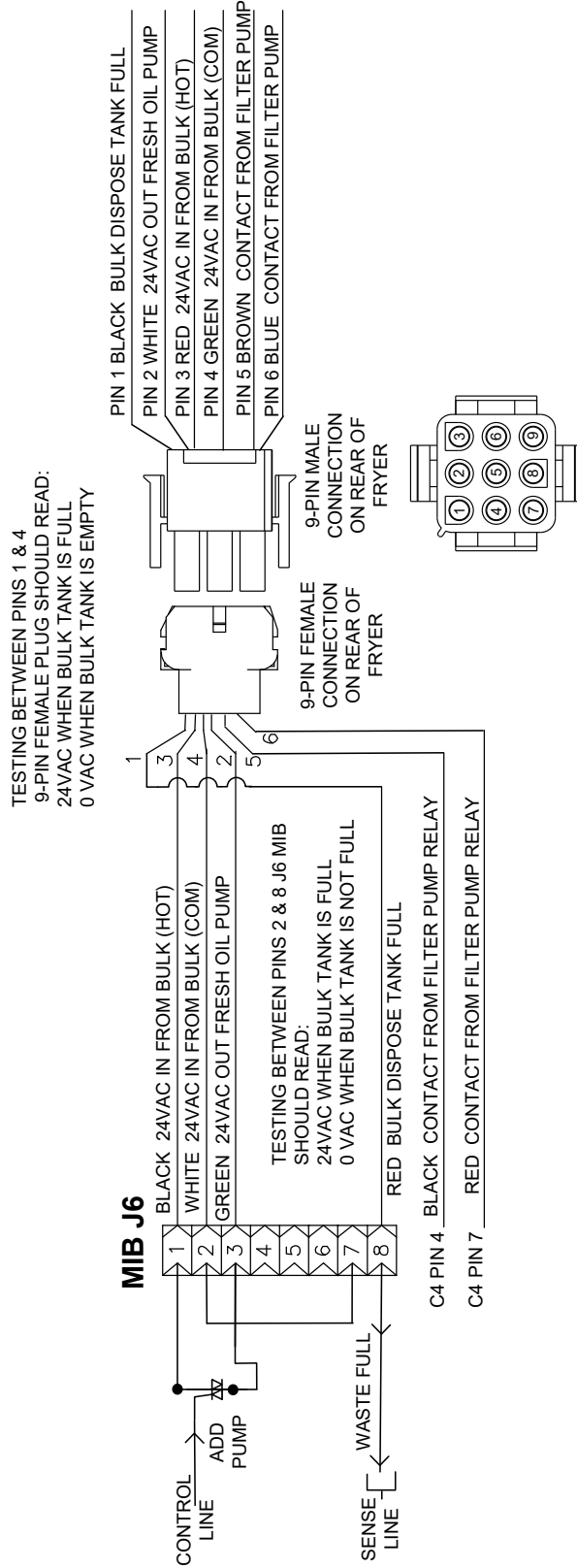

1.16.3 Frymaster FilterQuick™ Fryer and Bulk Oil System Plumbing Schematic

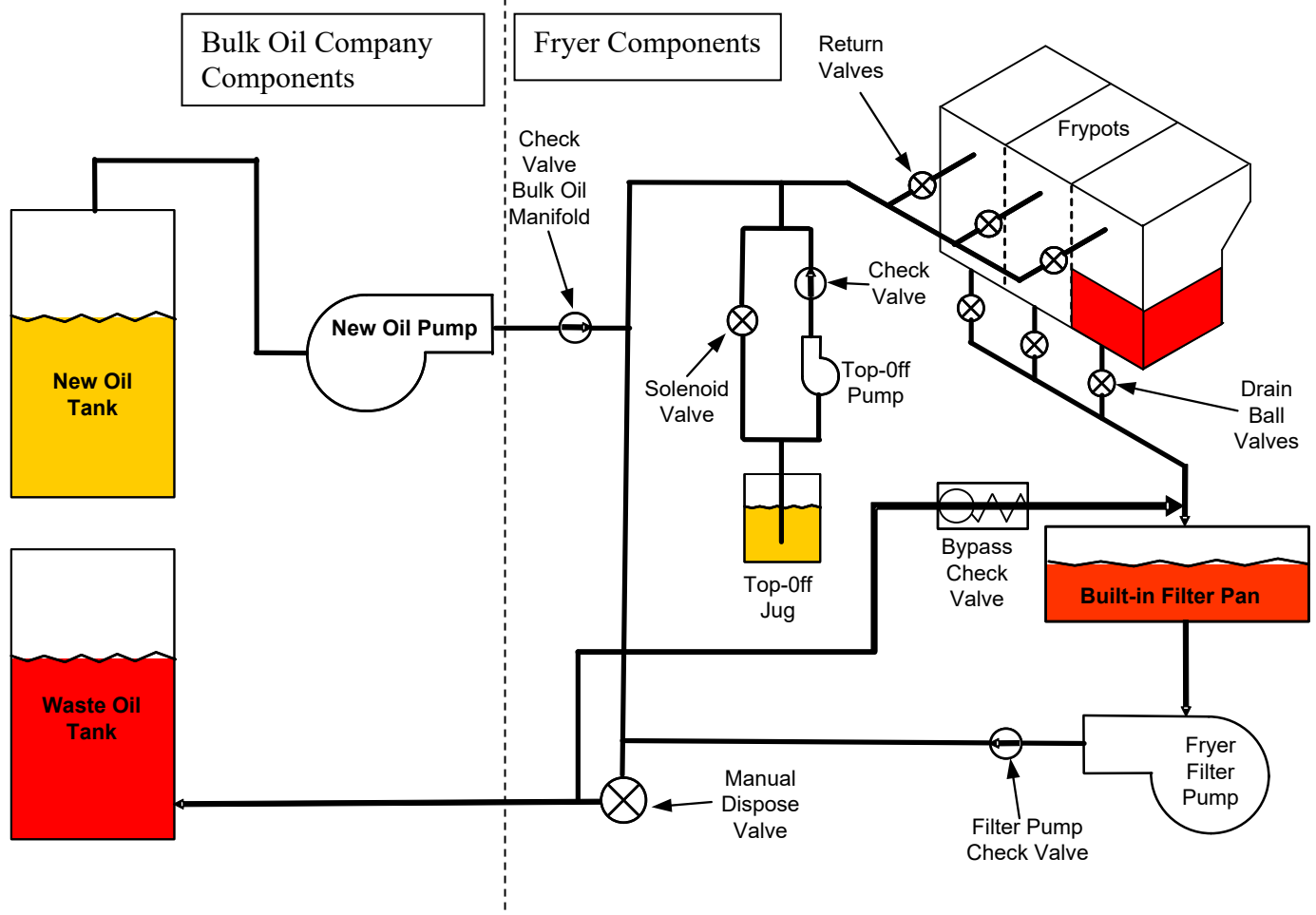

1.16.4 Bulk Oil Test Quick Reference

DISPOSE TO WASTE, REFILL VAT FROM BULK:

1. Hold down "Filter" button until controller beeps twice.
2. Scroll to "Dispose" using "Right Arrow" button then press "✓" button.
3. "Dispose? Yes/No" is displayed.*
4. Press "Yes" to dispose of oil in pot.
5. "Start Dispose" is displayed with blinking LED.
6. Pull the drain handle
7. "Draining" followed by "Flushing" is displayed.
8. "Vat Empty? Confirm" is displayed.
9. Press "Confirm".
10. "Close Drain" is displayed with blinking LED.
11. Push the drain handle in towards the fryer.
12. "Open Dispose Valve" is displayed.
13. Open dispose valve by pulling completely forward to start disposal.
14. "Disposing" is displayed for four minutes.
15. "Remove Filter Pan" is displayed.
16. Slide the filter pan slightly out of the fryer.
17. "Is Pan Empty? Yes No" is displayed.
18. Press "Yes" if filter pan is empty. Select "No" if pan still has oil in it.
19. "Insert Filter Pan" is displayed.
20. Insert the filter pan.
21. "Close Dispose Valve" is displayed.
22. Close dispose valve ensuring the handle is pushed completely towards the fryer.

23. "Fill Vat From Bulk? Yes/No" is displayed.
24. Press "Yes".
25. "Press and Hold Yes Arrow to Fill" alternating with "Yes" is displayed.
26. Hold down "Yes" to fill pot to desired level.
27. "Filling" is displayed while button is depressed.
28. "Continue Filling Yes/No" is displayed
29. Press "Yes" to continue filling or "No" to Exit program.

***NOTE:** If the waste tank is full, the controller displays "Waste Tank Full." Call bulk oil provider.

DISPOSE TO WASTE:

1. Hold down "Filter" button until controller beeps twice.
2. Scroll to "Dispose" using "Right Arrow" button then press "✓" button.
3. "Dispose? Yes/No" is displayed.*
4. Press "Yes" to dispose of oil in pot.
5. "Start Dispose" is displayed with blinking LED.
6. Pull the drain handle
7. "Draining" followed by "Flushing" is displayed.
8. "Vat Empty? Confirm" is displayed.
9. Press "Confirm".
10. "Close Drain" is displayed with blinking LED.
11. Push the drain handle in towards the fryer.
12. "Open Dispose Valve" is displayed.
13. Open dispose valve by pulling completely forward to start disposal.
14. "Disposing" is displayed for four minutes.
15. "Remove Filter Pan" is displayed.
16. Slide the filter pan slightly out of the fryer.
17. "Is Pan Empty? Yes No" is displayed.
18. Press "Yes" if filter pan is empty. Select "No" if pan still has oil in it.
19. "Insert Filter Pan" is displayed.
20. Insert the filter pan.
21. "Close Dispose Valve" is displayed.
22. Close dispose valve ensuring the handle is pushed completely towards the fryer.
23. "Fill Vat From Bulk? Yes/No" is displayed.
24. Press "No" if you wish to leave pot empty and exit.

***NOTE:** If the waste tank is full, the controller displays "Waste Tank Full." Call bulk oil provider.

FILL VAT FROM BULK:

1. Hold down "Filter" button until controller beeps twice.
2. Scroll down to "Fill Vat from Bulk" using "Right Arrow" button then press "✓" button.
3. "Fill Vat from Bulk? Yes/No" is displayed.
4. Press "Yes".
5. "Press and Hold Yes to Fill / Yes" is displayed.
6. Press and hold down "YES" to fill pot to desired level.
7. "Filling" is displayed during fill.
8. Release button to stop filling.
9. "Continue Filling? Yes/No" is displayed.
10. Press "NO" to exit.

FILL JUG FROM BULK:*

1. When "Top Off Oil Empty" is displayed, the top-off jug is empty.
2. To refill jug press and hold the orange reset button above the jug until the jug is full.
3. Release the button to stop filling.

***NOTE: The jug may not fill if any of the following are in progress:**

If FILTER NOW? YES/NO, CONFIRM YES/NO, or SKIM VAT is displayed, the fill jug button is disabled until either a filter is complete or until no is chosen.

The system also checks these conditions. The following must be met before jug fill is allowed.

- Solenoid closed
- Orange fill button pressed longer than 3 sec.
- Waste valve closed
- Filter Now? Yes/No, Confirm Yes/No, or Skim Vat cannot be displayed
- System power cycle (all boards – controllers, MIB, AIF and ATO) after changing setup from JIB to Bulk (use momentary reset). Ensure reset is pressed and held for at least ten seconds.
- No filtration or other filter menu selection can be in process.

Other factors that may not allow fill jug from bulk –

- Defective solenoid
- Defective switch
- Bulk fresh oil pump issue
- Bulk fresh oil relay issue

If using multiple fryer systems that are both attached to the bulk fresh oil system, they may not be able to fill both units at the same time if they have a bulk fresh oil unit with a single head. Some bulk fresh oil units have dual heads which can fill more than one fryer simultaneously.

1.17 AIF (Automatic Intermittent Filtration) Service Procedures

The AIF (Automatic Intermittent Filtration) board controls the actuators that open and close the drain and return valve. The AIF boards are located inside a protective housing under each frypot (see Figure 15).

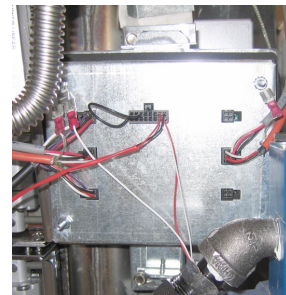

Figure 15

1.17.1 AIF (Automatic Intermittent Filtration) Troubleshooting

Problem	Probable Causes	Corrective Action
<p>Actuator doesn't function.</p>	<p>A. No power to the AIF board. B. Actuator is unplugged.</p>	<p>A. Check pins 5 and 6 of J2 at the MIB board. Should read 24VDC. Check voltage on pins 5 and 6 at the other end of harness and ensure 24VDC is present. Continue to check pins 5 and 6 for 24VDC on plugs J4 and J5 on the AIF boards. B. Ensure the actuator is plugged into the proper connection (J1 for FV return, J3 for DV return and J6 for FV drain and J7 for DV drain).</p>

Problem	Probable Causes	Corrective Action
Actuator doesn't function cont.	<p>C. AIF board failure.</p> <p>D. Actuator readings are out of tolerance.</p> <p>E. Actuator defective.</p>	<p>C. Check power on the connector of the problem actuator while trying to manually open or close an actuator. Pins 1 (Black) and 4 (White) should read +24VDC when the actuator is opening. Pins 2 (Red) and 4 (White) should measure -24VDC when the actuator is closing). If either voltage is missing, the AIF board is likely bad. Test the actuator by plugging into another connector. If the actuator operates, replace the board.</p> <p>D. Check resistance of the potentiometer between pin 3 (blue wire) and pin 4 (gray/white wire). Closed should read 0-560Ω. Open should read 3.8K Ω – 6.6K Ω.</p> <p>E. If proper voltages are present at the connector and actuator doesn't operate reset power to the fryer, if it still doesn't operate replace the actuator.</p>
Actuator functions on wrong vat.	<p>A. Actuator plugged into wrong connector.</p> <p>B. Locator pin is in wrong position.</p>	<p>A. Ensure the actuator is plugged into correct connection (J1 for FV return, J3 for DV return and J6 for FV drain and J7 for DV drain).</p> <p>B. Ensure the locator pin is in proper position in plug J2. See table B on page 1-65.</p>

1.17.2 AIF (Auto Intermittent Filtration) Actuator Board Pin Positions and Harnesses

Connector	From/To	Harness PN	Pin #	Function	Voltage	Wire Color
J1	FV Return	N/A	1	Ret + (Open)	24VDC	Black
			2	Ret – (Closed)	24VDC	Red
			3	Ret Position		Blue
			4	Ground		White
J2	FV AIF RTD	N/A	1	Ground		Red
	DV AIF RTD		2	FV - Temp		White
	Oil Level Sensor (Gas)		3	Ground		Red
			4	DV - Temp		White
			5	OIB Sensor FV from Pin 5 on J3 of Interface Bd	12VDC	Red
			6	OIB Sensor FV		Black
	Oil Level Sensor communication (Gas)		7	OIB Sensor DV from Pin 5 on J3 of Interface Bd	12VDC	Red
			8	OIB Sensor DV		Black
	Locator Pin		9	DV – OLS (Gas)		Black
			10	FV – OLS (Gas)		Red
			11	Locator Vat #5		Black
			12	Locator Vat #4		
	13		Locator Vat #3			
	14		Locator Vat #2			
	Locator		15	Locator Vat #1		
	16		Locator Signal		Black	
J3	DV Return	N/A	1	Ret + (Open)	24VDC	Black
			2	Ret – (Closed)	24VDC	Red
			3	Ret Position		Blue
			4	Ground		White
J4	MIB J2 or AIF J5	8074547 AIF Board Communication and Power	1	Ground		Black
			2	CAN Lo		Red
			3	CAN Hi		White
			4	5VDC+	5VDC	Black
			5	24VDC	24VDC	Red
			6	Ground		White
J5	AIF J4 or ATO J10	8074547 AIF Board Communication and Power	1	Ground		Black
			2	CAN Lo		Red
			3	CAN Hi		White
			4	5VDC+	5VDC	Black
			5	24VDC	24VDC	Red
			6	Ground		White
J6	FV Drain	N/A	1	Drain + (Open)	24VDC	Black
			2	Drain – (Closed)	24VDC	Red
			3	Drain Position		Blue
			4	Ground		White
J7	DV Drain	N/A	1	Drain + (Open)	24VDC	Black
			2	Drain – (Closed)	24VDC	Red
			3	Drain Position		Blue
			4	Ground		White

1.17.3 Replacing an AIF (Automatic Intermittent Filtration) Board

Disconnect the fryer from the electrical power supply. Locate the AIF board to be replaced under a frypot. Mark and unplug the harnesses. The AIF board assembly is held in place with one screw (see Figure 16). Remove the screw and the assembly drops down (see Figure 17) and the tab slides out of the bracket attached to the frypot (see Figure 18). Reverse steps to reassemble, ensuring that the new AIF assembly slides into the slot in the bracket. Once complete, **CYCLE POWER TO ENTIRE FRYER SYSTEM**. See section 1.15.6 to reset control power. Check software version # and if necessary update the software. If a software update is necessary, follow the instructions to update the software in section 1.19.

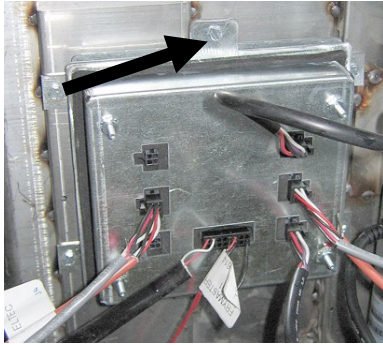

Figure 16

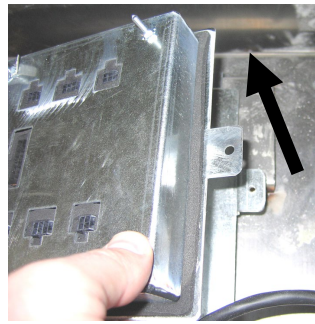

Figure 17

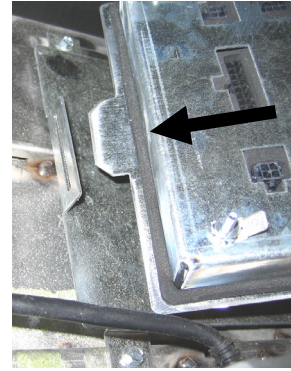

Figure 18

1.17.4 Replacing a Rotary Actuator

Disconnect the fryer from the electrical power supply. Locate the actuator to be replaced and mark and unplug the actuator. The actuators are held in place by two hex key screws. Loosen the 3/32" hex key screws. It may be necessary to remove a gas line to the burner when removing a drain actuator. Remove the actuator from the valve stem. Align the actuator with the valve stem and attach the new actuator. Tighten the two hex key screws. Reconnect power and test the actuator.

NOTE: Rotary actuators have two different part numbers and two different colors, which are mirror images of each other that correspond to their mounting position.

1.17.5 Oil Level Sensor

The oil level sensor is a device that is used to prevent dry firing of the frypot (see Figure 25). The sensor looks similar to a high limit. The sensor is energized when the controller is powered on with a soft on. The sensor heats up and detects the oil around it. During filtration when the oil is drained, it senses the difference between the oil and air. It is controlled with a board located next to the interface board (see Figure 26) and a separate egg shaped plastic device (see Figure 27) that contains additional electronics.

Use care when working with the sensor as temperatures may reach as high as 500°F (260°C).

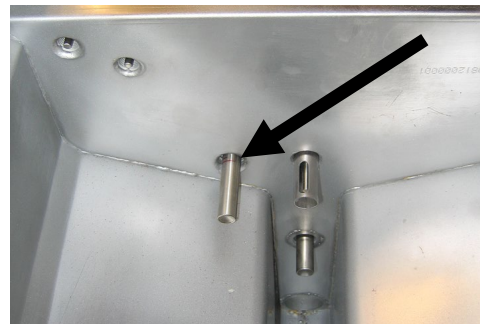

Figure 25

If oil is surrounding the heater, the oil will prevent the heater from ever reaching its setpoint. Once oil is removed during filtration the heater reaches setpoint and cycles a thermostat every four seconds. Since the cycle is only four seconds, the seven second delay is not made and the gas valve won't open.

The 120VAC (220-240VAC on Intl. units) is on T1 and T2 in the control box. It is switched with 12 volts traveling in from pin 5 of J3 and out to pins 5 and 7 on AIF J2 and back in on pin 8 from AIF J2 (DV) or pin 6 from AIF J2 (FV) across the relay coil.

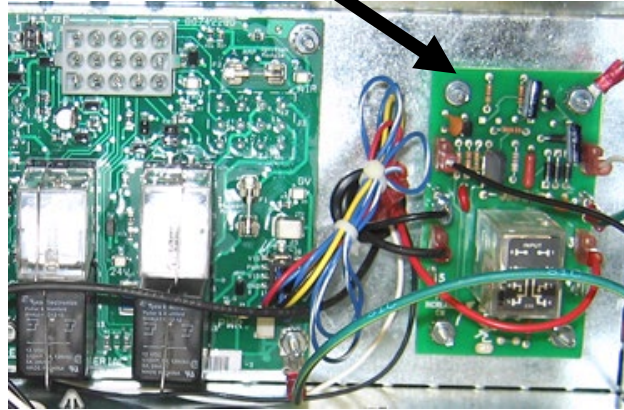

Figure 26



Figure 27

1.17.5.1 Oil Level Sensor Troubleshooting

Typical Sensor Related Failures

- Low temp but no call for heat (heat light)
- Intermittent IS VAT FULL? displays are primarily due to dirty OIB sensors or loose grounds. Ensure that the OIB sensors are clean as shown in Figure A.
 - This is usually due to a caramelized oil buildup on the sensor. Clean the oil level sensor with a scratch pad and power cycle the controller.
 - Check grounds from the OIB relay and 7 second timer board delay. When grounded to the stud on the interface board they have a tendency to loosen. They should NOT be grounded to interface board studs as shown in Figure B. If so they should be moved and be tightly grounded to stud in rear of the fryer as shown in Figure C.
- Stuck in melt cycle with no call for heat
- Filter error (IS VAT FULL?) with oil in the filter pan (no oil in the vat)

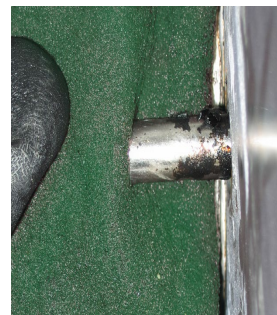

Figure A

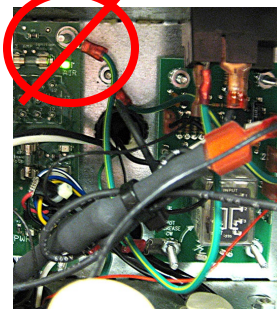
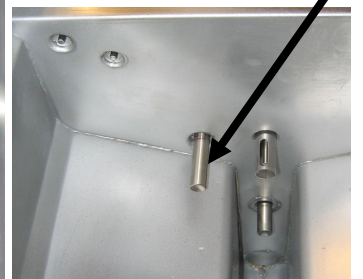

Figure B

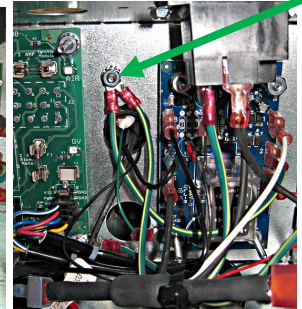

Figure C

If the controller doesn't exit melt cycle or continues to display low temp and does not heat, and gas supply, gas valve, etc. have been checked and no heat lamp illuminates because no call for heat is initiated, then follow these steps:

- Check (see diagram next page)
 - Power to oil sensor (from oil level sensor relay in component box). Check pin 5 on AIF J2 (DV) or pin 7 on AIF J2 (FV) for 12VDC from interface board.
 - Power to heater/relay coil on relay board. Check voltage to the coil between pins 8 and 1 to ensure that 120VAC (220-240VAC on Intl. units) is present with oil in the vat. If the vat is empty, the power will cycle 4 seconds on, 4 seconds off.
 - Check between pin 3 and 2 on the relay board reads 5VDC for air and 0VDC for oil. A common message for a shorted harness or issue is "IS DRAIN CLEAR?" with oil in the filter pan.
 - Check ground on pin 2 on relay board to stud for a secure ground.
 - Check AIF communication harness. Interrupted communication will prevent the fryer from heating.
 - If the oil level sensor is cycling 4 sec. on/off and oil is surrounding the sensor, the sensor may have a carbon build up that is self insulating the sensor. Use a scratch pad to remove carbon build up.

1.17.5.2 Oil Level Sensor Diagram

NOTE: See page 1-70 for alternate time delay relays.

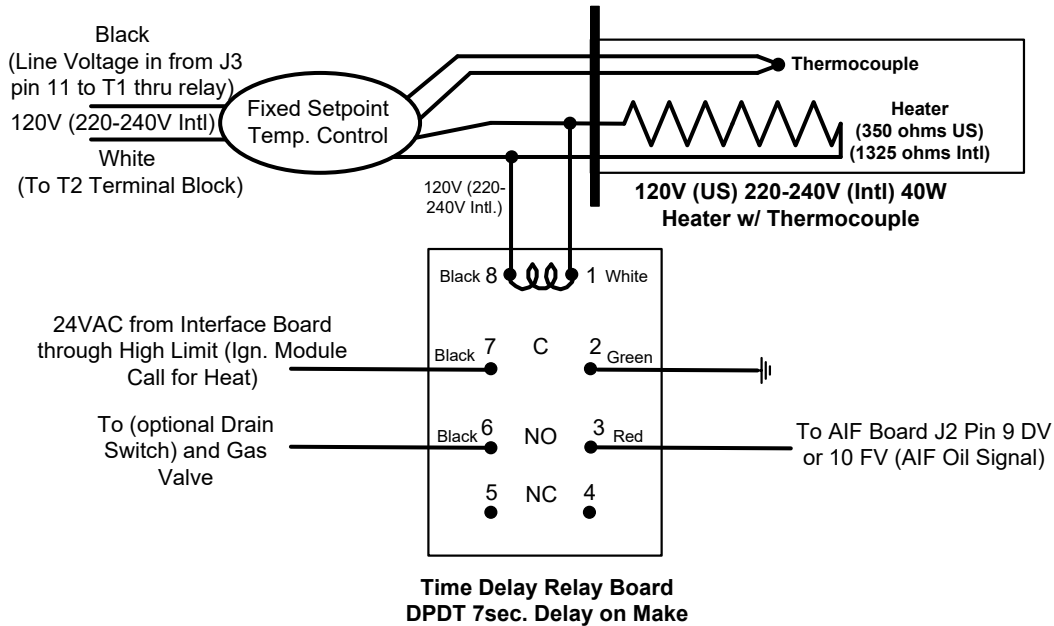

1.18 FilterQuick™ Controller Service Procedures

1.18.1 FilterQuick™ Controller Troubleshooting

Problem	Probable Causes	Corrective Action
No Display on Controller.	<ul style="list-style-type: none"> A. Controller not turned on. B. No power to the fryer. C. Controller has failed. D. Damaged controller wiring harness. E. Power supply component or interface board has failed. 	<ul style="list-style-type: none"> A. Press the ON/OFF switch to turn the controller on. B. If the controller cord is not plugged in, the controller will not activate. Verify controller power cord is plugged in and that circuit breaker is not tripped. C. Swap the controller with a controller known to be good. If controller functions, replace the controller. D. Swap with a harness known to be good. If controller functions, replace the harness. E. If any component in the power supply system (including the transformer and interface board) fail, power will not be supplied to the controller and it will not function.
Controller locks up.	Controller error.	Remove and restore power to the controller.
Controller displays RECOVERY FAULT.	Recovery time exceeded maximum time limit for two or more cycles.	Silence the alarm by pressing the ✓ button. Check that fryer is heating properly. Maximum recovery for gas is 2:25. If this error continues to appear call your FAS.
Controller displays CALL TECH	Typically shown during software update. Also may be that parameter data has been corrupted or lost.	Press the FILTER button to bypass and continue.
Controller displays ERROR RM SDCRD	Defective SD Card	Replace card with another card.

Problem	Probable Causes	Corrective Action
FILTER and CLEAN AND FILTER won't start.	Temperature too low.	Ensure fryer is at setpoint before starting these functions.
Controller displays FILTER BUSY or WAIT FOR FILTER.	A. Another filtration cycle is still in process. B. Controller error.	A. Wait until the previous filtration cycle ends to start another filtration cycle or until the MIB board has reset. This may take up to one minute. B. If message is still displayed with no activity, ensure the filter pan is empty and remove and restore ALL power to the fryer.
Controller displays IS DRAIN CLEAR?	Clogged drain or Oil Level Sensor is malfunctioning.	The oil level sensor detects that oil is not draining possibly due to clogged drain. Ensure drain is not clogged. If drain is not clogged, see oil level sensor troubleshooting on page 1-51.
Controller displays OIL SENSOR FAIL	Oil level sensor is not functioning properly.	Check the oil level sensor and ensure that it is working properly.
Controller displays SERVICE REQUIRED followed by the error.	An error has occurred.	Press YES to silence alarm. The error is displayed three times. See list of issues in section 1.17.5. Fix issue. The controller displays SYSTEM ERROR FIXED? YES/NO . Press YES and follow prompts. Pressing NO will allow the fryer to cook in most cases, but error will be redisplayed every 15 minutes.
Controller display is in wrong temperature scale (Fahrenheit or Celsius).	Incorrect display option programmed.	See section 1.18.2 on page 1-47 to change temperature scale.
Controller displays CHANGE FILTER PAPER.	Filter error has occurred, filter paper clogged, 24 hour filter pad change prompt has occurred or change filter paper was ignored on a prior prompt.	Change the filter paper and ensure the filter pan has been removed from the fryer for a minimum of 30 seconds. Do NOT ignore CHANGE FILTER PAPER prompts.
Controller displays HOT-HI-1.	Frypot temperature is more than 410°F (210°C) or, in CE countries, 395°F (202°C).	This indicates that the vat temperature has exceeded certain parameters and has discontinued heating. It is also displayed during a high limit test.
Controller displays HI-LIMIT.	Controller in high-limit test mode.	This is displayed only during a test of the high-limit circuit and indicates that the high-limit has opened properly.
Controller displays INSERT PAN.	A. Filter pan is not fully inserted into fryer. B. Missing filter pan magnet. C. Defective filter pan switch.	A. Pull filter pan out and fully reinsert into fryer. B. Ensure the filter pan magnet is in place and if missing replace. C. If the filter pan magnet is fully against the switch and controller continues to display INSERT PAN , switch is possibly defective.

Problem	Probable Causes	Corrective Action
Controller displays vat temperature alternating with <i>MLT-CYCL</i>.	Frypot temperature is below 180°F (82°C).	This display is normal when the fryer is first turned on while in the melt cycle mode. To bypass the melt cycle press the “COOL” button. The controller displays EXIT MELTP alternating with YES NO . Press the YES button to exit melt. If the display continues, the fryer is not heating.
Controller displays <i>TEMP PROBE FAILURE</i>.	A. Problem with the temperature measuring circuitry including the probe. B. Damaged controller wiring harness or connector.	A. This indicates a problem within the temperature measuring circuitry. Check resistance of probe, if faulty replace probe. B. Swap the controller wiring harness with one known to be good. If problem is corrected, replace the harness.
Controller displays <i>HEATING FAILURE</i>.	Failed controller, failed gas valve, open drain valve, failed interface board, open high-limit thermostat.	Turn off the vat with the issue. The error is displayed if the fryer loses its ability to heat oil. Common issues are open drain valve or closed or failed gas valves. It sometimes is seen when air is in the gas line. It is also displayed when the oil temperature is above 450°F (232°C) and the high-limit thermostat has opened, halting the heating of the oil.
Controller displays <i>HI 2 BAD</i>.	Controller in high-limit test mode.	This is displayed during a test of the high-limit circuit to indicate if the high-limit has failed.
Controller displays <i>HELP HI-2 or HIGH LIMIT FAILURE</i>.	Failed high-limit.	This is displayed to indicate the high-limit has failed.
Fryer filters after each cook cycle.	Filter after setting incorrect or software update issue.	Overwrite the filter after setting by re-entering the filter prompt value in Product Setup. Press and hold the ✓ button until MAIN MENU changing to PRODUCT SETUP is displayed. Press the ✓ button. ENTER CODE is displayed. Enter 1650 . Scroll down to Filter Prompt and set value. Ensure that the right arrow is pressed after entering the value to save the setting.
Controller displays <i>LOW TEMP</i>, heating indicator cycles on and off normally but fryer does not heat.	A. Dirty oil level sensor B. Failed controller. C. Damaged controller wiring harness. D. Open connection in high-limit circuit.	A. Clean carbon build up off oil level sensor using a no scratch pad. B. Replace controller. C. Replace controller wiring harness. D. Check high limit circuit starting at the control box connector working to the high-limit.
Controller displays software for only controller or MIB but not all boards.	Loose or damaged harness	Check that all harnesses between controllers, MIB, AIF and ATO are secure. Ensure 24VDC is present on pins 5 & 6 of J2 on MIB board and on J4 or J5 of AIF board. Check for loose or broken pins/wires. If the problem persists, swap out controller from one bank to another and cycle power on the fryer.

Problem	Probable Causes	Corrective Action
<p>Controller displays IS VAT FULL? YES NO after a filter function.</p>	<p>A. An error has occurred due to carbon buildup on oil level sensor. Normal after some filter menu functions when filling.</p> <p>B. All the oil may not have returned during a filter function due to dirty or clogged filter paper, clogged filter pump, filter pump thermal overload, improperly installed filter pan components, worn or missing O-rings, cold oil or an actuator problem.</p> <p>C. OIB relay ground issue.</p>	<p>A. If answering yes directs to clean oil sensor, clean oil level sensor with a scratch pad and retry. Otherwise press ▲ (YES) if the vat is full, otherwise press ▼ (NO) and follow prompts.</p> <p>B. Check to ensure that the probable causes are remedied. Follow the prompts to refill the vat. (Follow the steps in the flowchart in section 1.18.5.)</p> <p>C. See item B in section below.</p>
<p>Controller displays IS VAT FULL? YES NO during a cook or in idle mode with an audible alarm.</p>	<p>A. An error has occurred due to carbon buildup on oil level sensor.</p> <p>B. OIB relay/time delay relay board ground issue.</p> <p>C. CAN communication issues, component failure issues.</p>	<p>A. If answering yes directs to IS OIL SENSOR CLEAN? CONFIRM, clean the oil level sensor with a scratch pad and power cycle the controller.</p> <p>B. Check ground wire from OIB relay/time delay relay board. If attached to interface board lug mount stud, move the ground wire and attach it to the stud on rear wall of component box, with the ground wire from the 7 second time delay relay board.</p> <p>C. If the issue continues check software versions to verify CAN communication. Check AIF connections from AIF board J2 pin 9 DV or pin 10 FV to pin 3 of time delay relay board. Check OIB relay/time delay relay board in component box.</p>
<p>Controller displays IS OIL SENSOR CLEAN? CONFIRM during a cook or in idle mode with an audible alarm.</p>	<p>A. The oil level sensor may be coated with caramelized oil.</p> <p>B. OIB relay ground issue.</p> <p>C. CAN communication issues, component failure issues.</p>	<p>A. Clean sensor with scratch pad.</p> <p>B. See item B in section above.</p> <p>C. If the issue continues check software versions to verify CAN communication. Check AIF connections. Check OIB relay in component box.</p>

1.18.2 FilterQuick™ Controller Useful Codes

To enter any of the following codes: Press and hold the ✓ button until **MAIN MENU** changing to **PRODUCT SETUP** is displayed. Press ► to scroll to **TECH MODE** and press the ✓ button. **ENTER CODE** is displayed. Enter a code number below to perform a function.

- **Clear E-Log, Clear Passwords, Change Lane Count, Change Hold Mode and Perform High Limit Test, – Enter 3000.**
- **Reset Factory Menu** - Enter **3322**. The controller display flashes and quickly counts from 1-40 and switches to **OFF**. (**NOTE:** This will delete any hand-entered menu items).
- **Change from F° to C°** - Enter **1658**. The controller displays **OFF**. Turn the controller on and check temperature to see the temperature scale. If the desired scale is not displayed, repeat.
- **Reset RECOVERY FAULT CALL SERVICE – Enter 0042.**

The following codes require the removal and reinsertion of the J3 locator plug on the rear of the controller before entering the code.

- **Reset CALL TECH Message** - Disconnect board locator plug (J3). Reinsert plug. Enter **1000**. Controller display switches to **OFF**. Remove and then restore power to the controller using the 20-pin plug. If this error is displayed, replace the controller.

- **Reset BADCRC Message** - Disconnect board locator plug (J3). Reinsert plug. Enter **9988**. Controller display switches to **OFF**. Remove and then restore power to the controller using the 20-pin plug. Replace the controller.

PASSWORDS

- **Product Setup Mode:** Press and hold the ✓ button until **MAIN MENU** changing to **PRODUCT SETUP** is displayed. Press the ✓ button. **ENTER CODE** is displayed. Enter **1650**.
- **Vat Setup Mode:** Press and hold the ✓ button. **MAIN MENU** changing to **PRODUCT SETUP** is displayed. Press ► to scroll to **VAT SETUP** and press ✓. **ENTER CODE** is displayed. Enter **1656**.
- **Tech Mode:** Press and hold the ✓ button until **MAIN MENU** changing to **PRODUCT SETUP** is displayed. Press ► to scroll to **TECH MODE** and press ✓. **TECH MODE** is displayed. Press the ✓ button. **ENTER CODE** is displayed. Enter **3000** or a code from above.

1.18.3 Service Required Errors

A **SERVICE REQUIRED** error alternating with **YES** displays on the controller. After **YES** is pressed the alarm is silenced. The controller displays an error message from the list below three times with the location of the error. Then the controller displays **SYSTEM ERROR FIXED? YES/NO**. Press **YES** if fixed. If **NO** is chosen the system returns to cook mode for 15 minutes then redisplay error until issue is fixed.

1.18.4 Error Log Codes

Refer to page 1-52, Vat Setup for access to the E-log. The ten most recent errors are listed from A-J, with A being the most recent error.

CODE	ERROR MESSAGE	EXPLANATION
E03	ERROR TEMP PROBE FAILURE	Temp probe reading out of range
E04	HI 2 BAD	High limit reading is out of range.
E05	HOT HI 1	High limit temperature is past more than 410°F (210°C), or in CE countries, 395°F (202°C)
E06	HEATING FAILURE	A component has failed in the high limit circuit such as controller, interface board, contactor or open-high limit.
E07	ERROR MIB SOFTWARE	Internal MIB software error
E08	ERROR ATO BOARD	MIB detects ATO board connection lost; ATO board failure
E09	ERROR PUMP NOT FILLING	Oil not returning to vat quickly. Possible problems: dirty pad, bad or missing O-rings, tripped or defective filter pump, actuators or linkage.
E10	ERROR DRAIN VALVE NOT OPEN	Drain valve failed to open; the valve's position is unknown.
E11	ERROR DRAIN VALVE NOT CLOSED	Drain valve failed to close; the valve's position is unknown.
E12	ERROR RETURN VALVE NOT OPEN	Return valve failed to open; the valve's position is unknown.

CODE	ERROR MESSAGE	EXPLANATION
E13	ERROR RETURN VALVE NOT CLOSED	Return valve failed to close; the valve's position is unknown.
E14	ERROR AIF BOARD	MIB detects AIF missing; AIF board failure
E15	ERROR MIB BOARD	Cooking controller detects MIB connections lost; Check software version on each controller. If versions are missing, check CAN connections between each controller; MIB board failure
E16	ERROR AIF PROBE	AIF RTD reading out of range
E17	ERROR ATO PROBE	ATO RTD reading out of range
E19	CAN TX FULL	Connection between controllers lost
E20	INVALID CODE LOCATION	SD card removed during update
E21	FILTER PAPER PROCEDURE ERROR (Change Filter Paper)	25 hour timer has expired or dirty filter logic has activated
E22	OIL IN PAN ERROR	The MIB has reset the oil in pan flag.
E23	CLOGGED DRAIN (Gas)	Vat did not empty during filtration
E24	OIL SENSOR FAILED (Gas)	Oil is back sensor failed.
E25	RECOVERY FAULT	Recovery time exceeded maximum time limit.
E27	LOW TEMP ALARM	Oil is approximately 35°F (19.4°C) below setpoint.
E28	HIGH TEMP ALARM	Oil temperature has risen 40°F (22.2°C) higher than setpoint. If temperature continues to rise, the high limit will shut the burner off when temperature reaches 425°F (218°C) Non-CE or 395°F (202°C) CE.
E70	OQS TEMP HIGH	Oil temperature is too high for a valid OQS reading. Filter at a temperature between 300°F (149°C) and 375°F (191°C).
E71	OQS TEMP LOW	Oil temperature is too low for a valid OQS reading. Filter at a temperature between 300°F (149°C) and 375°F (191°C).
E72	TPM RANGE LOW	The TPM is too low for a valid OQS reading. The incorrect oil type may be selected in the setup menu. The sensor may not be calibrated for the oil type. See oil type chart.
E73	TPM RANGE HIGH	The TPM reading is too high for a valid OQS reading. Dispose the oil.
E74	OQS ERROR	The OQS has an internal error. Power cycle the entire fryer battery. Check to see if OQS software version appears.
E75	OQS AIR ERROR	The OQS is detecting air in the oil. Check the O-rings and check/tighten prescreen filter to ensure no air is entering the OQS sensor.
E76	OQS ERROR	The OQS sensor has a communication error. Check connections to the OQS sensor. Power cycle the entire fryer battery.
E77-E80	N/A CAN messages	Engineering use only in FilterQuick 3000. These are not error codes to be concerned about.

1.18.5 FilterQuick™ Filter Error Flowchart

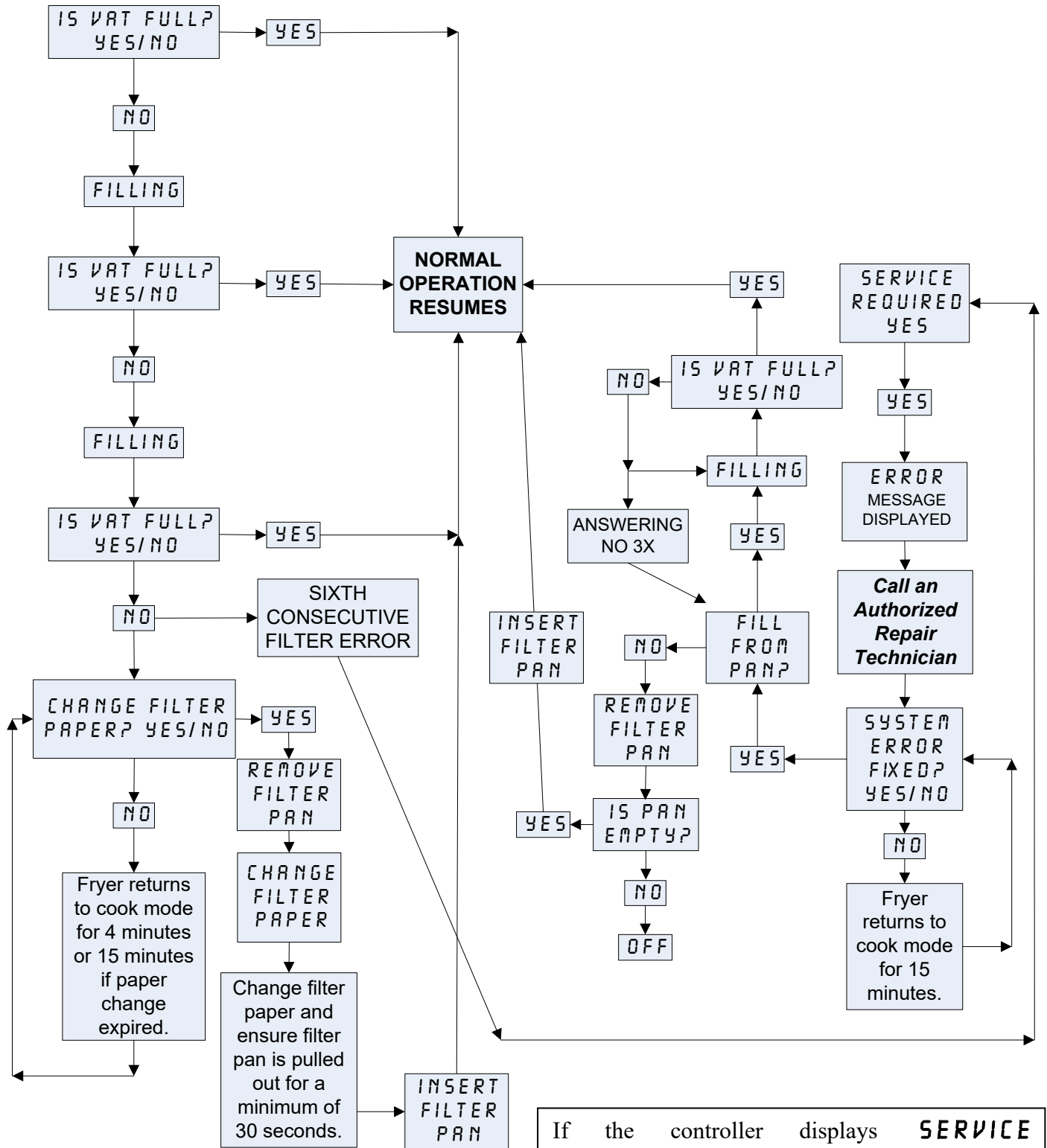

This chart follows the process of clearing a filtration issue. The prompt is displayed when any of the following occur:

1. a clogged filter paper,
2. a tripped or defective filter pump,
3. a leaky O-ring on the pick-up tube,
4. a failed drain valve/actuator, or
5. a failed return valve/actuator.

If the controller displays **SERVICE REQUIRED**, the fryer can be used in most cases by answering **NO** when the prompt for **SYSTEM ERROR FIXED? YES NO** is displayed. The message repeats every 15 minutes until the issue is repaired and error cleared by a answering **YES** when **SYSTEM ERROR FIXED? YES NO** is displayed.

1.18.6 Clogged Drain/Failed Oil Sensor Error Flowchart

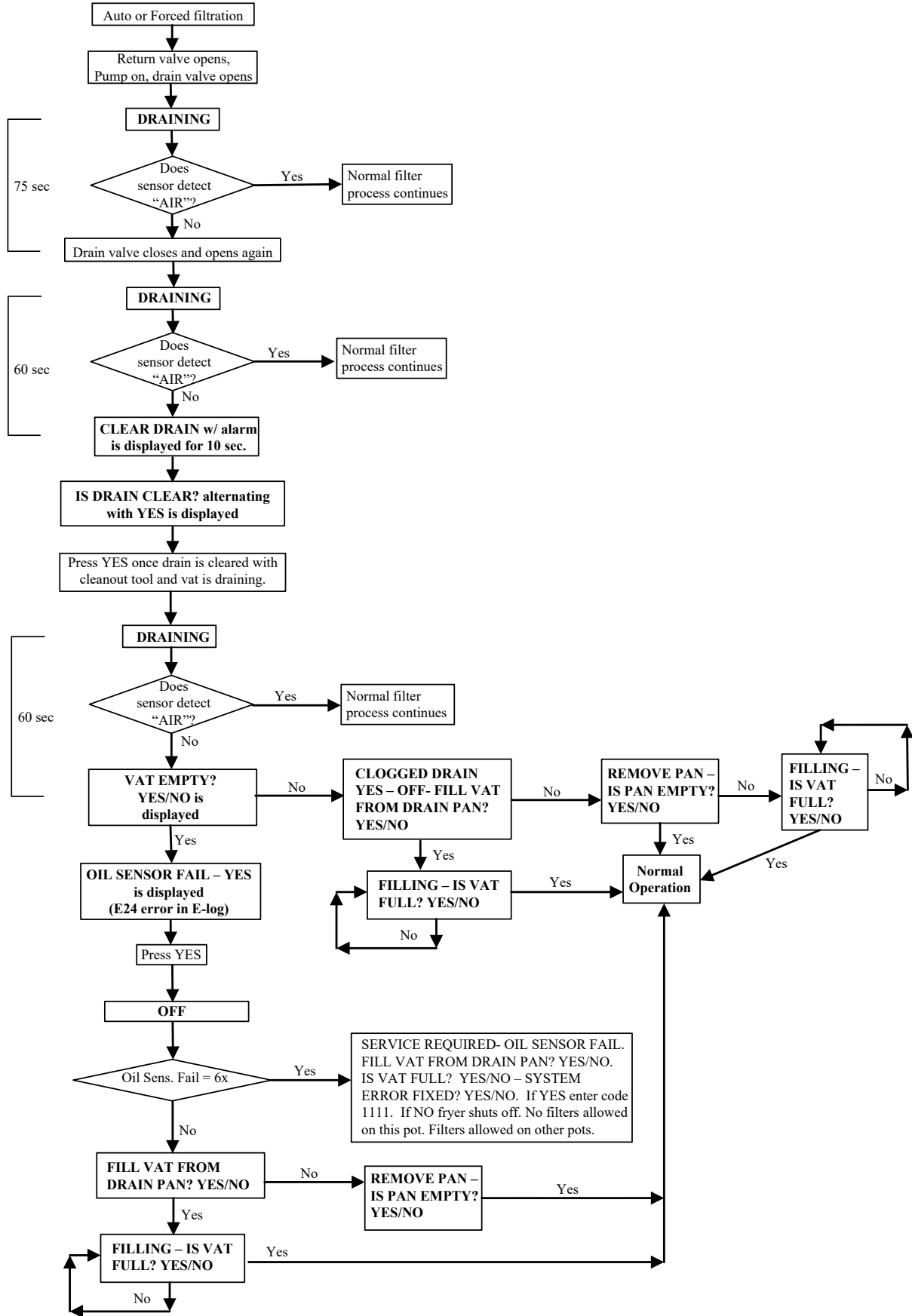

1.18.7 Menu Trees

1.18.7.1 FilterQuick™ Controller Setup Menu Tree

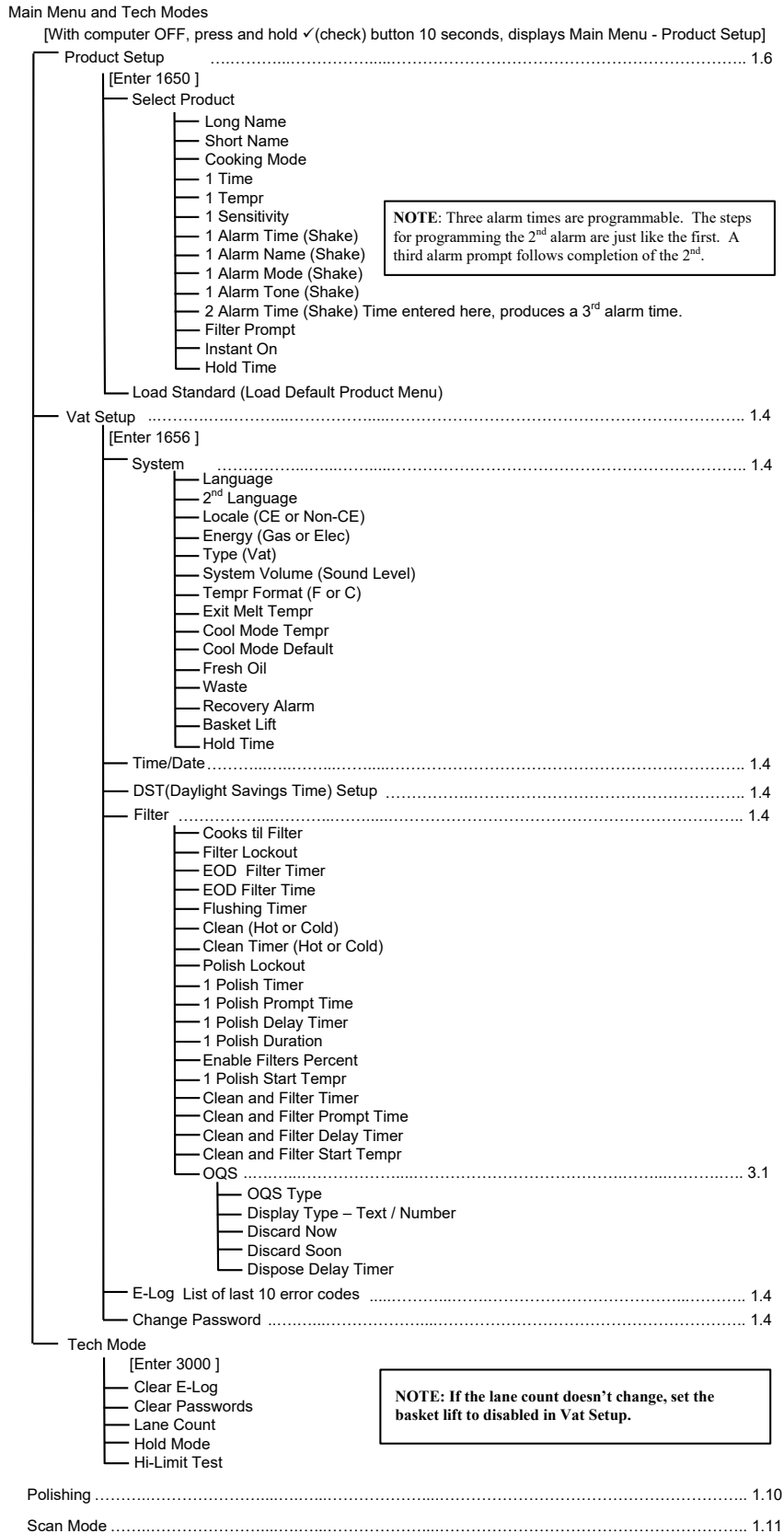

1.18.7.2 FilterQuick™ Filter and Info Mode Menu Tree

Filter Menu 1.9

- [With computer OFF, press and hold FILTER button]**
- Dispose
 - (Dispose to SDU / Fill from JIB)
 - (Dispose to Bulk or Front / Fill from JIB)
 - (Dispose to Bulk / Fill from Bulk)
- Drain to Pan
- Clean (Hot [Boil Out] or Cold [Cold Soak])
 - (Dispose to SDU / Fill from JIB)
 - (Dispose to Bulk or Front / Fill from JIB)
 - (Dispose to Bulk / Fill from Bulk)
- Pan to Waste (Bulk only)
- Fill Vat from Pan
- Fill Vat from Bulk (Bulk only)

Filter Menu 1.9

- [With computer ON, press and hold FILTER button]**
- Filter
- Clean and Filter
- OQS (Oil Quality Sensor) (Available only if installed and enabled.)
- Dispose
 - (Dispose to SDU / Fill from JIB)
 - (Dispose to Bulk or Front / Fill from JIB)
 - (Dispose to Bulk / Fill from Bulk)
- Drain to Pan
- Pan to Waste (Bulk only)

Info Mode 1.5

- [Press and hold ✓(check) button]**
- Last Dispose Stats
- Daily Stats
- Selected Period Stats
- Last Load Stats
- TPM

1.18.8 FilterQuick™ Controller Board Pin Positions and Harnesses

Connector	From/To	Harness PN	Pin #	Function	Voltage	Wire Color
J1	SD Card					
J2	Interface Board to Controller	8075165 SMT Controller to Interface Board Harness	1	12VAC In	12VAC	Black
			2	Ground		
			3	12VAC Return In	12VAC	
			4	FV Heat Demand		
			5	V Relay	12VDC	
			6	DV Heat Demand		
			7	R/H B/L	12VDC	
			8	Analog Ground		
			9	L/H B/L	12VDC	
			10	ALARM		
			11	Sound Device	5VDC	
			12	ALARM		
			13	FV Probe		
			14	Common Probes		
			15	DV Probe		
			16			
			17			
18						
19						
20						
J3	Interface Board Ground to Controller	Controller Locator Harness	1	Vat #1		Black
			2	Vat #2		
			3	Vat #3		
			4	Vat #4		
			5	Vat #5		
			6	Ground		
J4	Drain Switch and LED	1085672	1	Ground		Black
			2	Push Pull Switch In		Red
			3	Ground		Black
			4	Drain Indicator LED		Red
J6	Next Controller J7 or Network Resistor	8074546 Controller Communication Harness	1	Ground		Black
			2	CAN Lo		Red
			3	CAN Hi		White
			4	5VDC+	5VDC	Green
			5	24VDC	24VDC	Yellow
			6	Ground		Brown
J7	MIB J1 or previous Controller J6	8074546 Controller Communication Harness	1	Ground		Black
			2	CAN Lo		Red
			3	CAN Hi		White
			4	5VDC+	5VDC	Green
			5	24VDC	24VDC	Yellow
			6	Ground		Brown

1.18.9 OQS (Oil Quality Sensor) Troubleshooting

Problem	Probable Causes	Corrective Action
<p>No TPM results displayed.</p>	<p>A. Temperature too low or too high. B. Loose pre-screen filter. C. Missing, cracked or worn O-rings. D. Dirty filter paper. E. TPM too high. F. Error code.</p>	<p>Check the following items A-E and perform another OQS filter.</p> <p>A. Ensure the vat is at setpoint temperature. B. Inspect the pre-screen filter and ensure it is screwed in tightly. C. Inspect the O-rings on the filter pan and ensure they are both present and that they are not missing, cracked or worn. If so replace them. D. Ensure the filter paper is not clogged and clean filter paper is used. Did the vat refill the first time for the previous filter? If not change the filter paper. E. Dispose of the oil. F. Check error log for any OQS errors E70-76. See explanation and solution in section 1.18.4.</p>
<p>Controller does not display OQS software version.</p>	<p>A. Loose or damaged harness. B. Defective OQS sensor.</p>	<p>A. Check harnesses between controllers and OQS sensor are secure. Ensure 5VDC is present on pins 4 & 6 of J6 and J7 of the controller. Check for loose or broken pins/wires. If the problem persists, cycle power on the fryer. B. Defective OQS sensor.</p>

1.19 Loading and Updating Software Procedures

Updating the software takes approximately 30 minutes. The software only needs to be loaded in **ONE** controller and it will update **all** the controllers and boards in the system. Typically this is done on the far left controller. To update the software, follow these steps carefully:

1. Switch all controllers to **OFF**. Press the temperature button to check current controller/MIB/AIF/ATO software versions.
2. Remove the bezel and remove the two screws on the left side cover plate of the controller board.
3. With the controller folded down, insert the SD card, with the contacts facing down and the notch on the bottom right (see Figure 28 and 29), into the slot on the left side of the controller.
4. Once inserted, **UPGRADE IN PROGRESS** appears on the left display and **WAIT** on the right.
5. The display then changes to **CC UPDATING** on the left and the percentage completed appears on the right. The display counts up to 100 on the right, changing to a flashing **BOOT**. **DO NOT REMOVE THE CARD UNTIL THE DISPLAY PROMPTS TO DO SO IN STEP 8.**
6. Then **UPGRADE IN PROGRESS** is displayed on the left display and **WAIT** on the right again followed by **COOK HEX, MIB HEX, AIF HEX** ending with **ATO HEX** displayed on the left and the percentage complete on the right.
7. The display then changes to **REMOVE SD CARD** on the left and **100** on the right.
8. Remove the SD card using the fingernail slot on the top of the SD card.
9. Once the SD card is removed the display changes to **CYCLE POWER**.
10. Cycle the control power using the hidden reset switch behind the right control box. **ENSURE THE SWITCH IS HELD FOR 10 SECONDS. WAIT ANOTHER 20 SECONDS UNTIL THE MIB BOARD HAS FULLY RESET BEFORE CONTINUING.**
11. When the update is complete the controller displays **OFF**. The MIB display will remain blank while software is loading, changing to show the vat numbers. Once the LED's stop blinking, the MIB board will display **A**.
12. Cycle the control power using the hidden reset switch behind the right control box again. **ENSURE THE SWITCH IS HELD FOR 10 SECONDS. WAIT ANOTHER 20 SECONDS UNTIL THE MIB BOARD HAS FULLY RESET BEFORE CONTINUING.**
13. **With the controller displaying OFF, VERIFY software update by pressing the temperature button to check updated Controller/MIB/AIF/ATO version on each controller. IF ANY BOARDS DID NOT UPDATE, REPEAT THE PROCESS STARTING WITH STEP 3.**
14. Press the temperature button again.
15. Press the EXIT button to escape.
16. Once the software has been updated and the versions are correct, replace the cover and screws covering the SD card slot.
17. Reinstall the screws attaching the controllers and bezel by reversing steps 2 through 5.



Figure 28

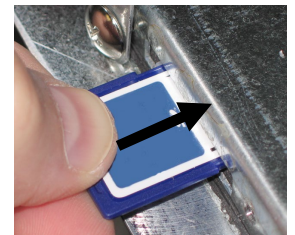
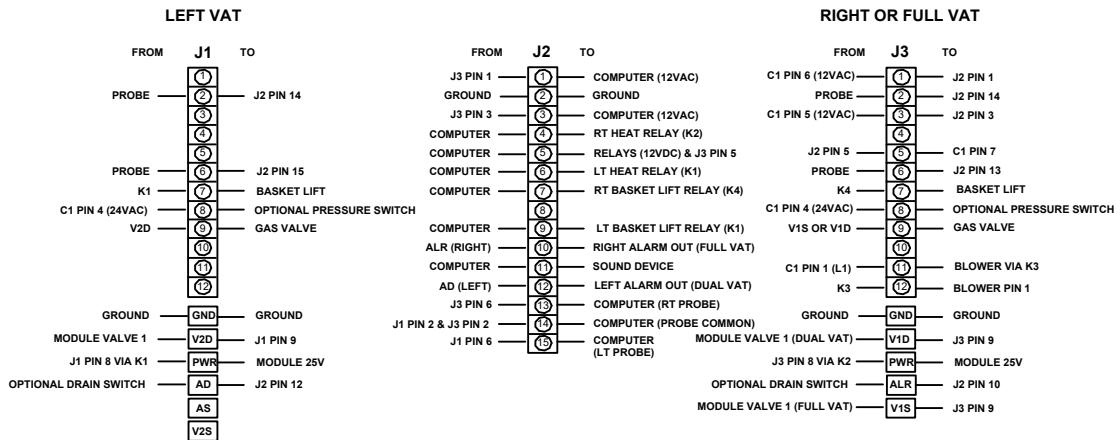
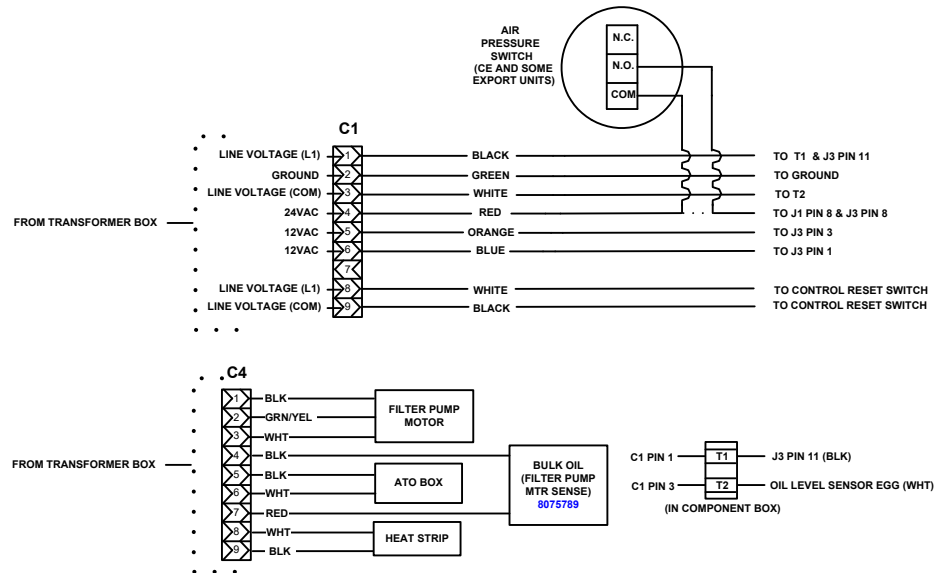

Figure 29

1.20 Principal Wiring Connections



1.21 Wiring Diagrams

1.21.1 Main FQG 230/430 120V Export

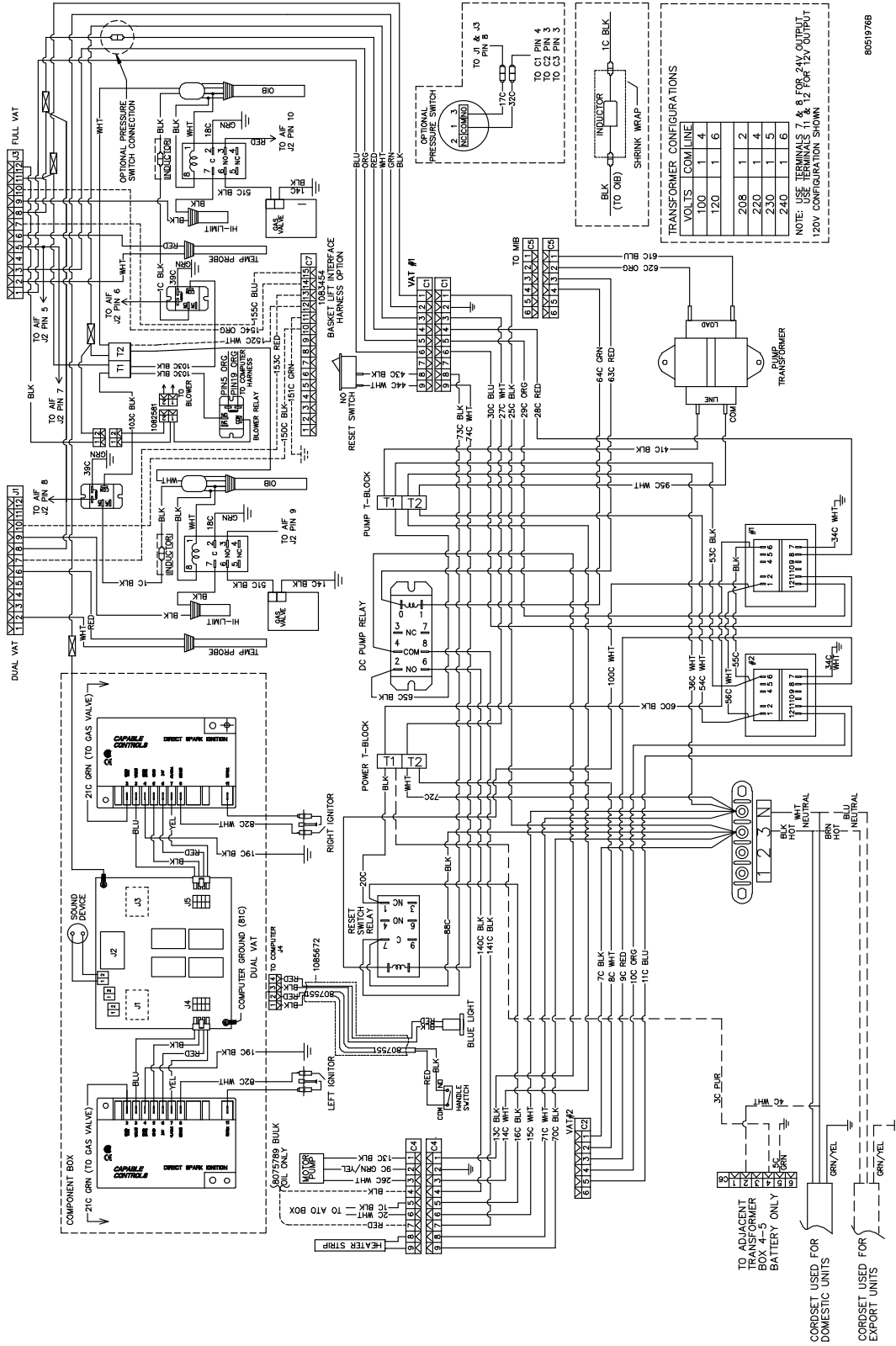

80519768

1.21.1.2 Main FQG 230/430 120V CE Fenwal Module GIVEC

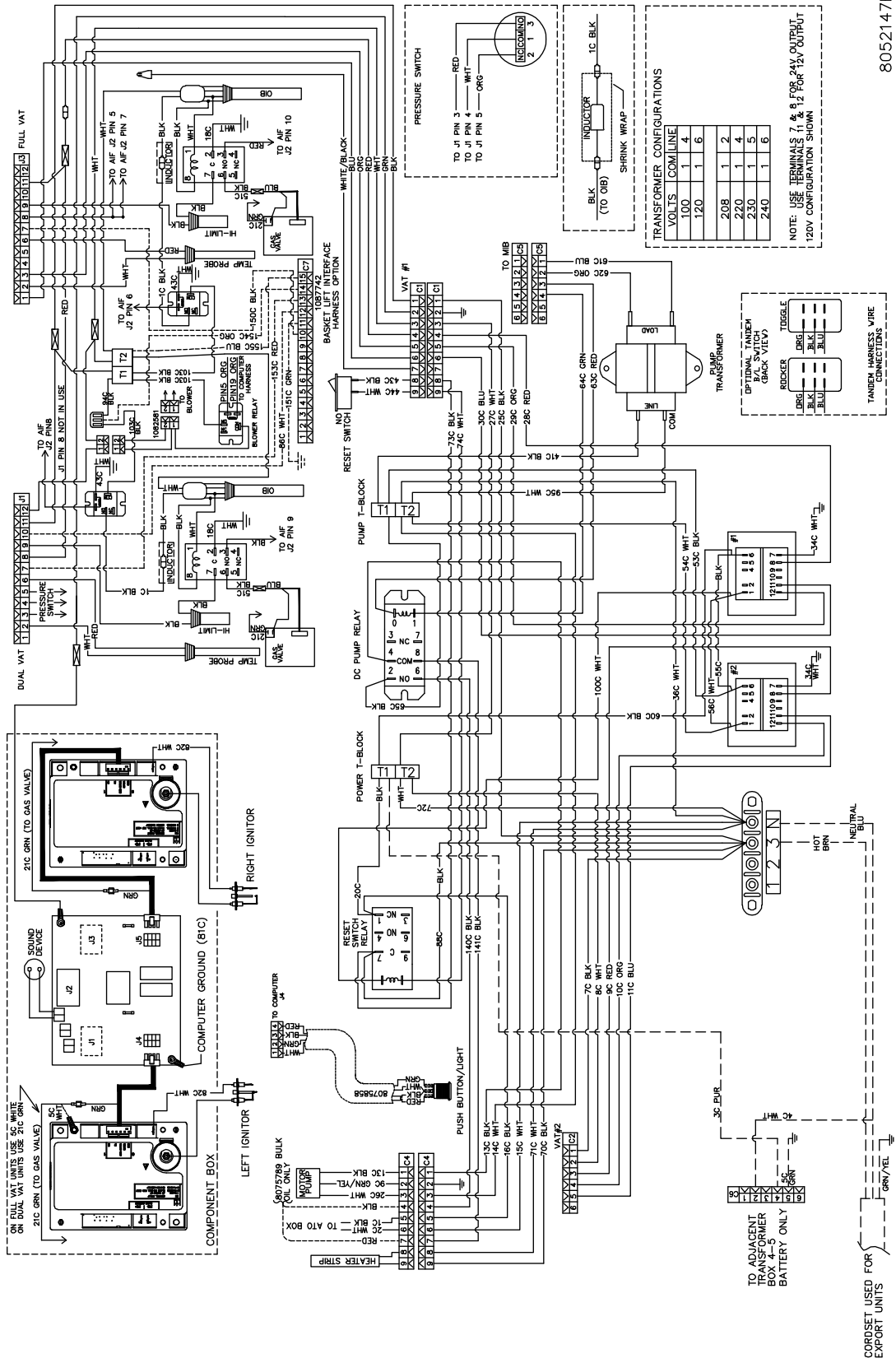

8052147B

1.21.2 Main FQG 230/430 Australia

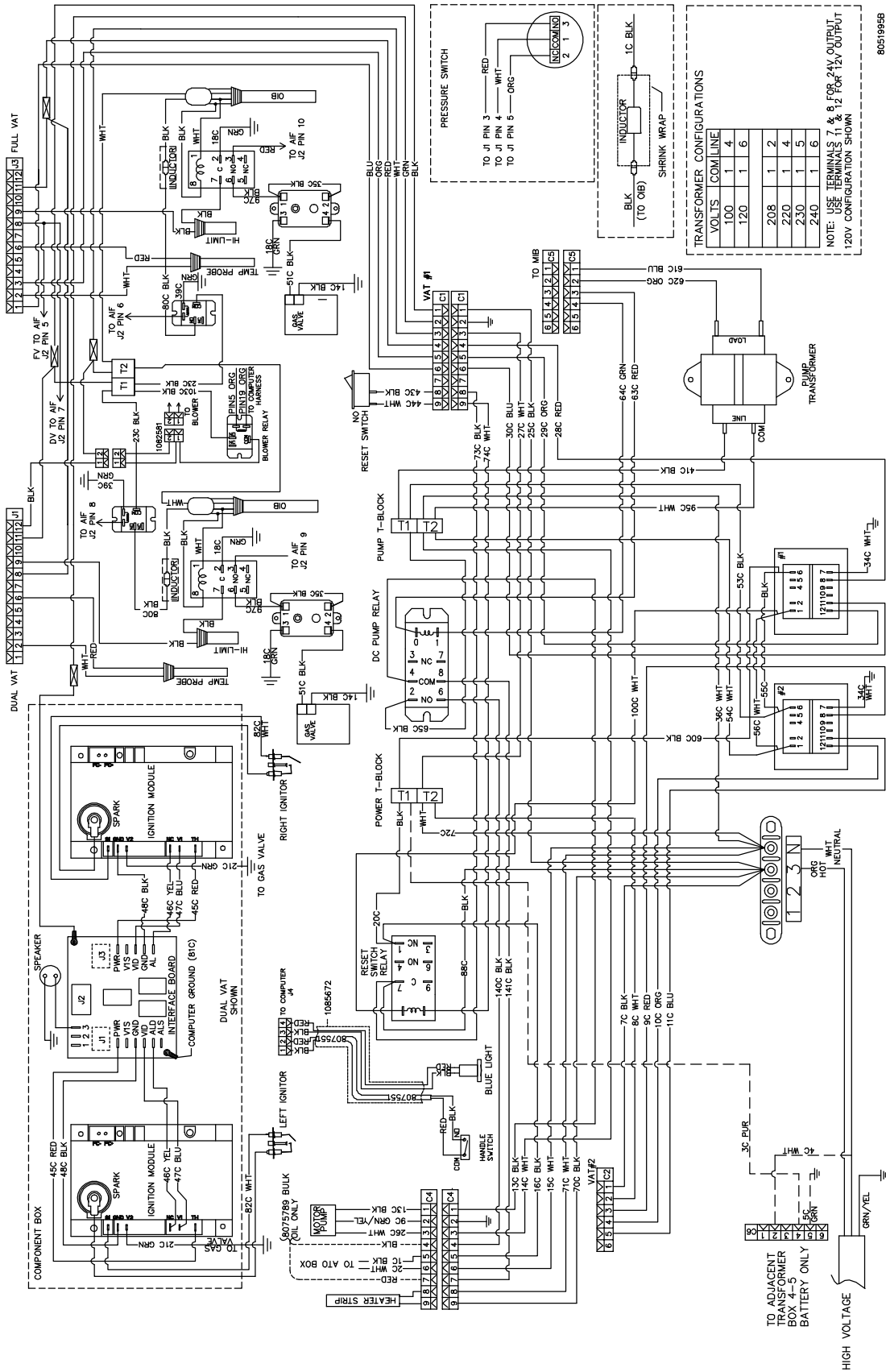

8059959

1.21.3 Main FQG 230/430 120V Export with Solid Shortening

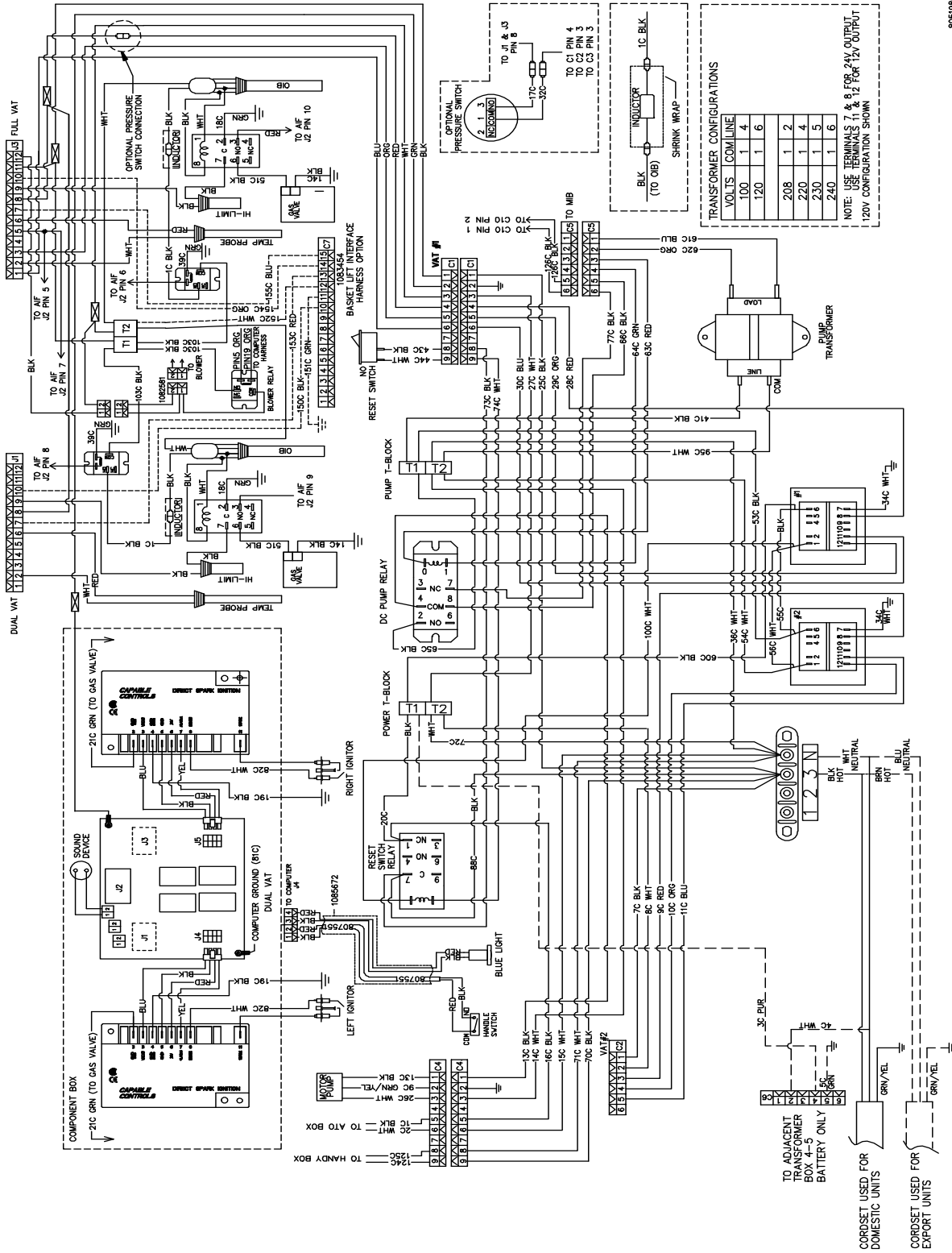

8051986B

1.21.3.2 Main FQG 230/430 CE Fenwal GIVEC with Solid Shortening

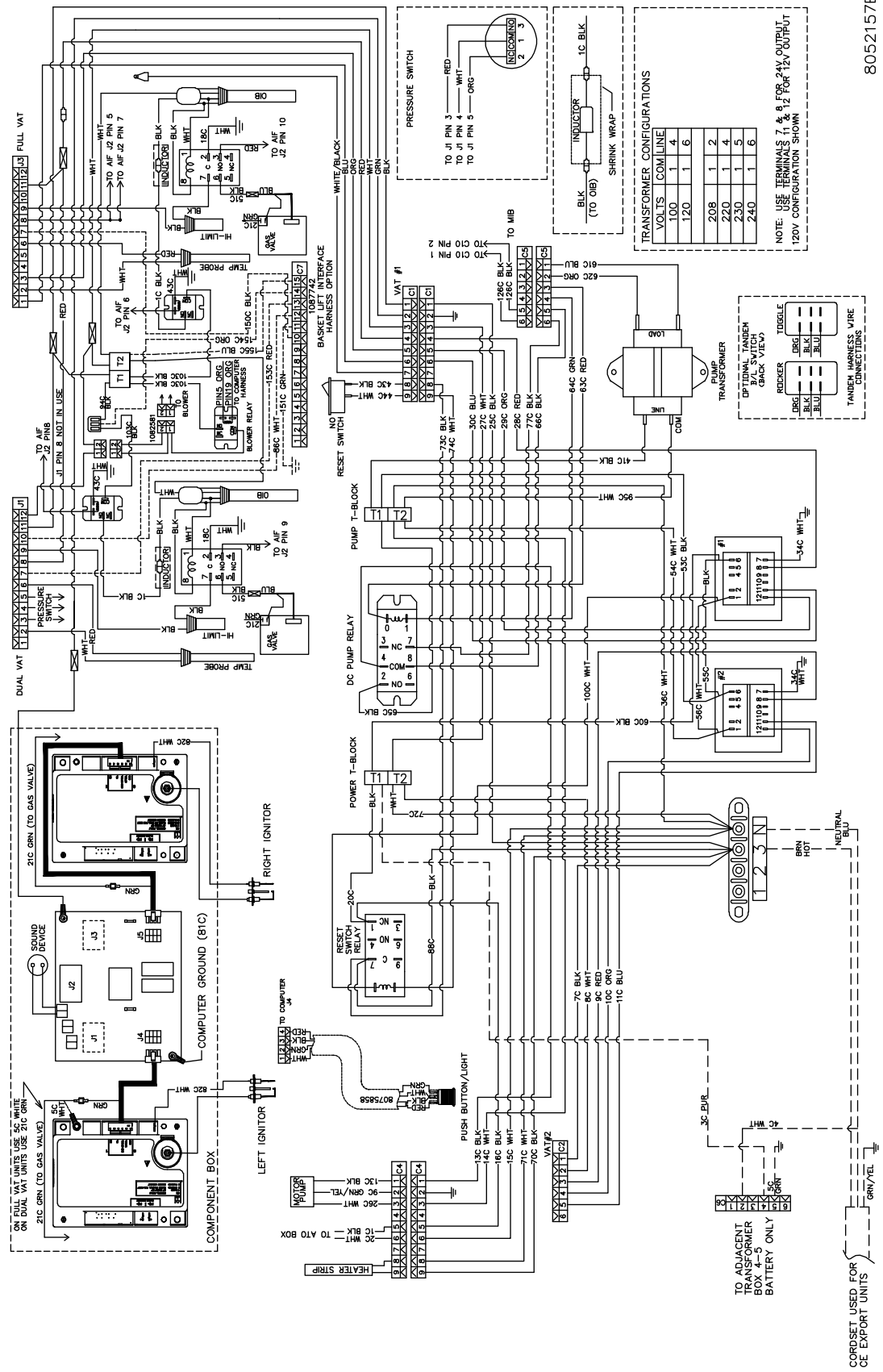

8052157B

1.21.4 Main FQG 230/430 Australia with Solid Shortening

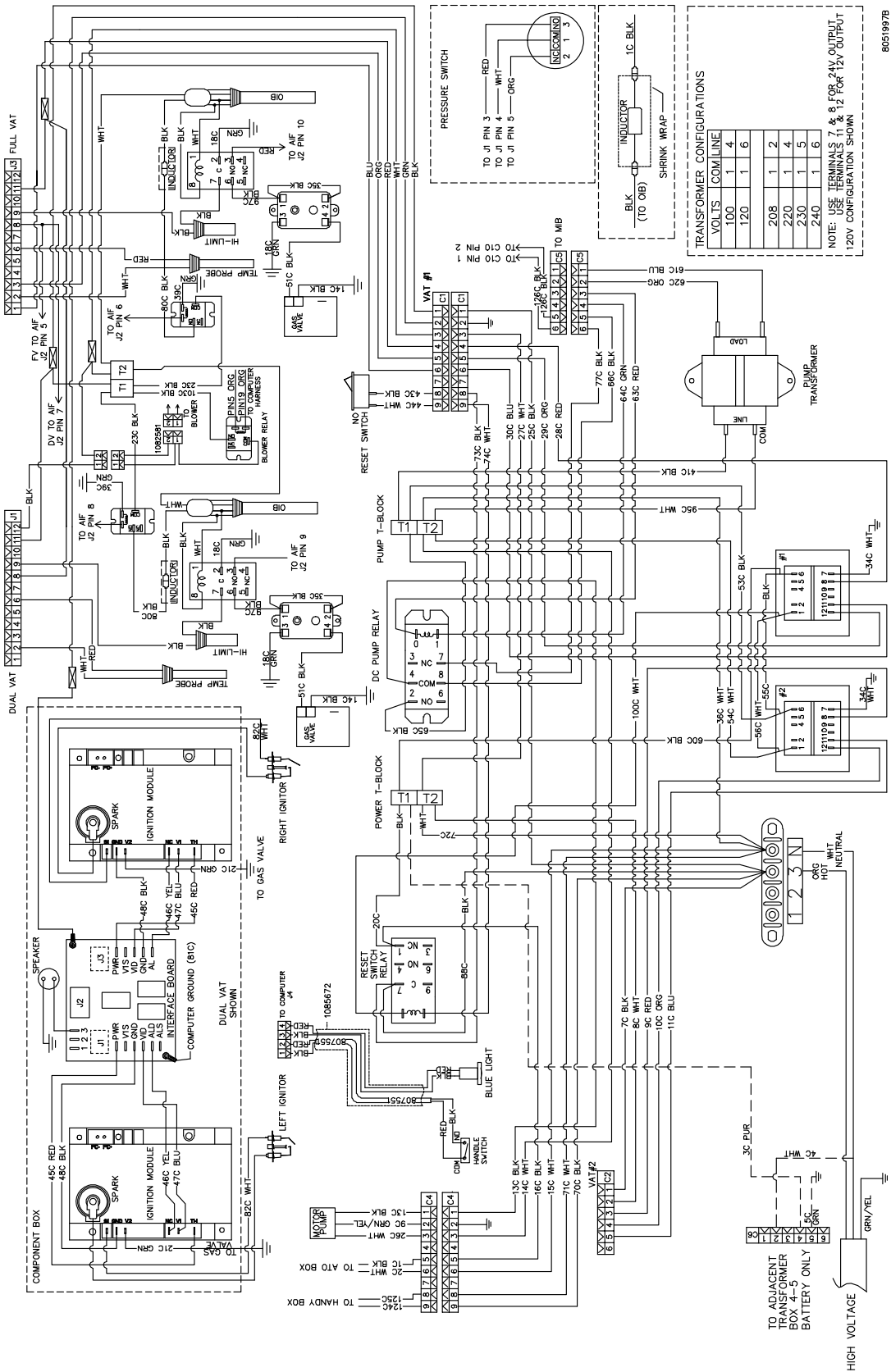

1.21.5 Main FQG 330/530 120V Export

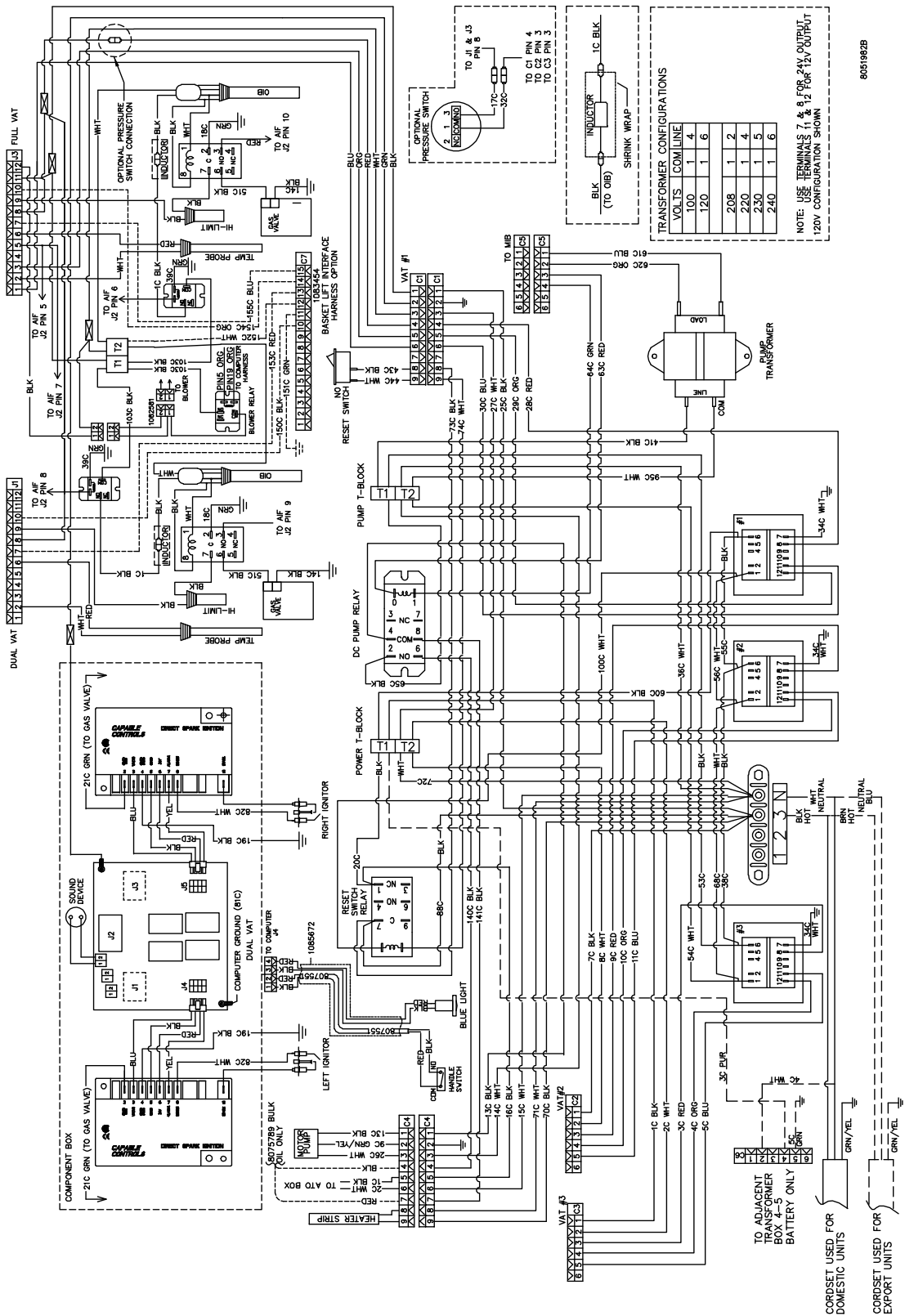

8051982B

1.21.5.2 Main FQG 330/530 CE Fenwal GIVEC

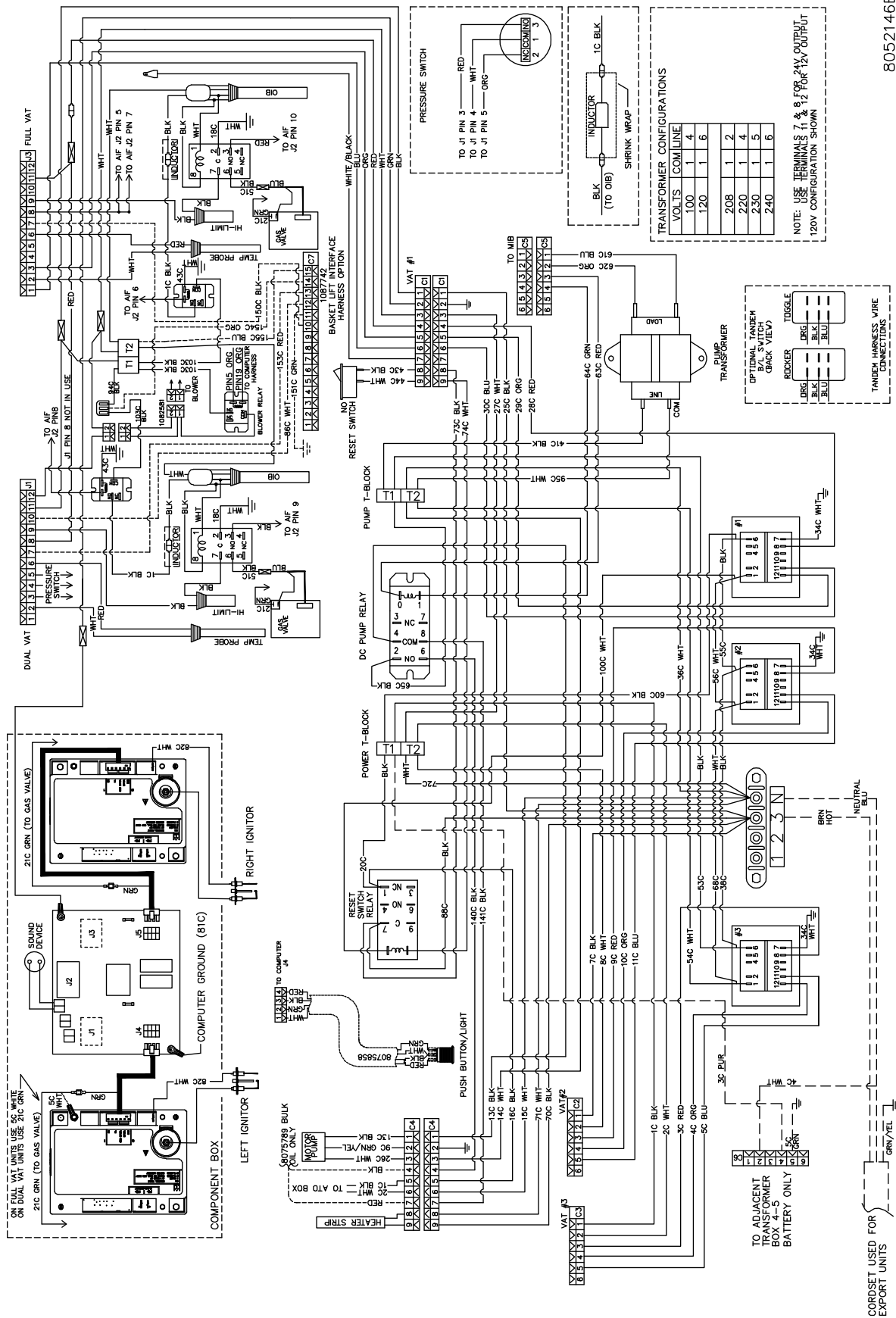

8052146B

CORSET USED FOR EXPORT UNITS

1.21.6 Main FQG 330/530 Australia

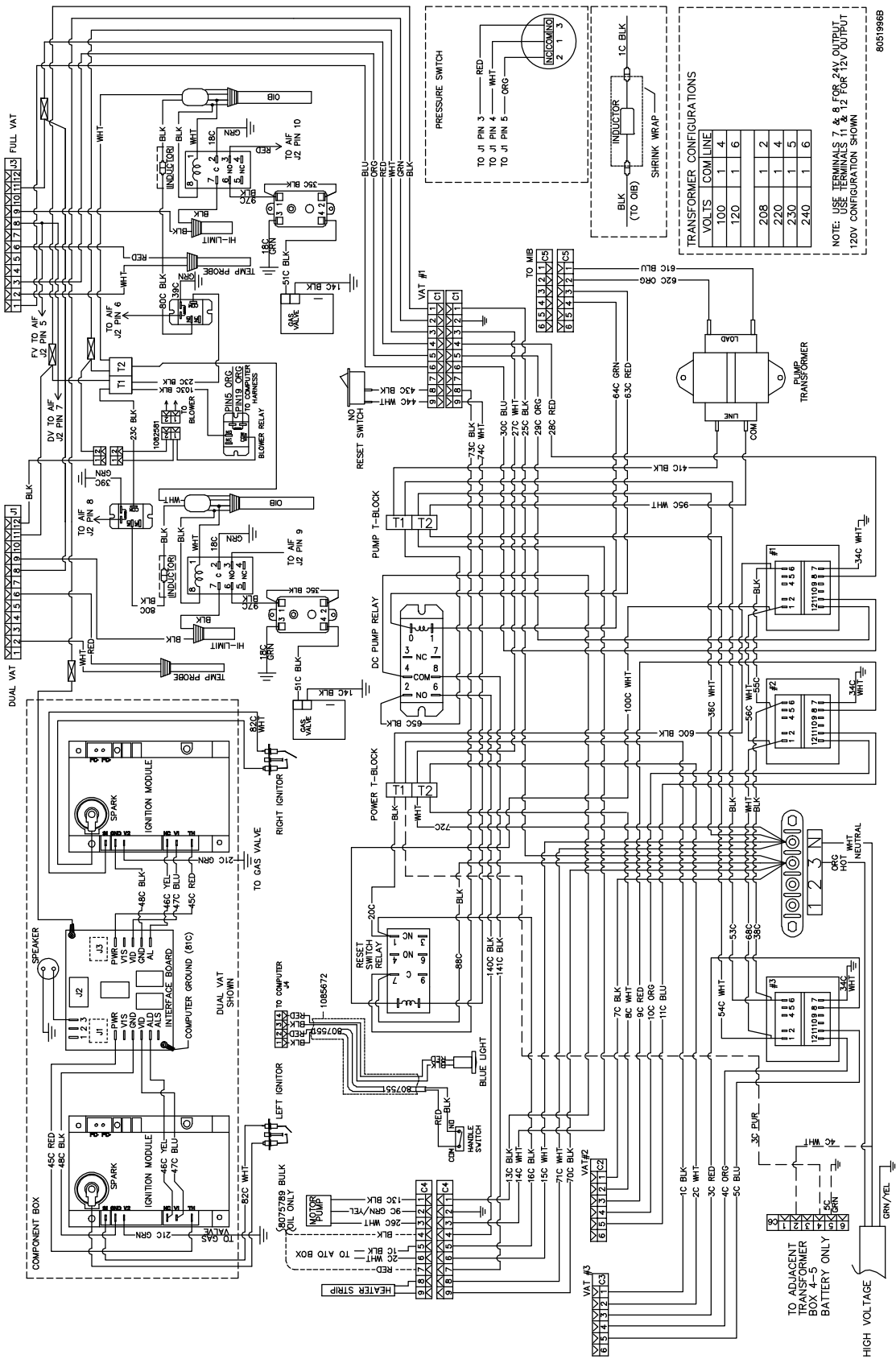

1.21.7 Main FQG 330/530 120V Export with Solid Shortening

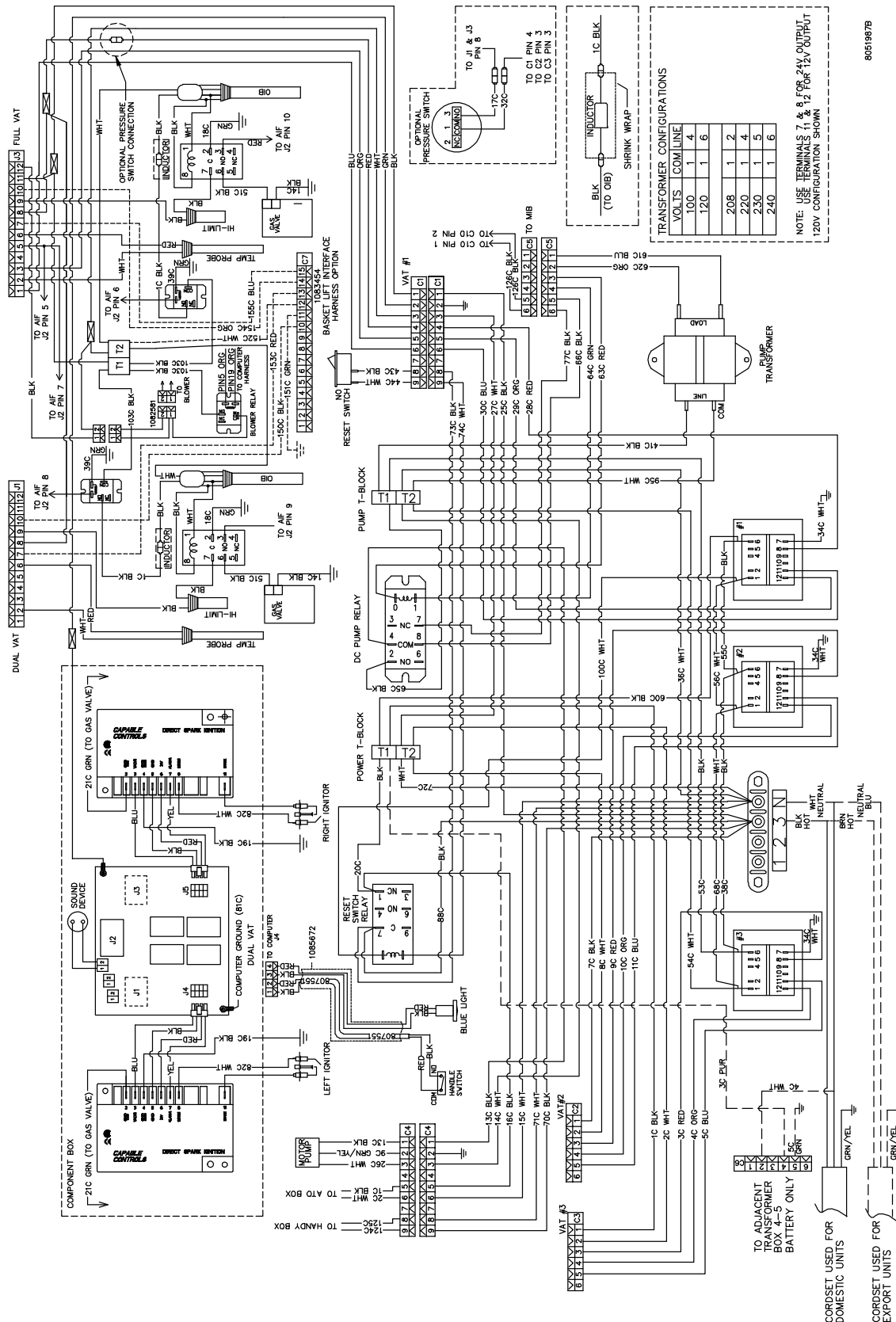

8051987B

1.21.7.2 Main FQG 330/530 120V CE Fenwal GIVEC with Solid Shortening

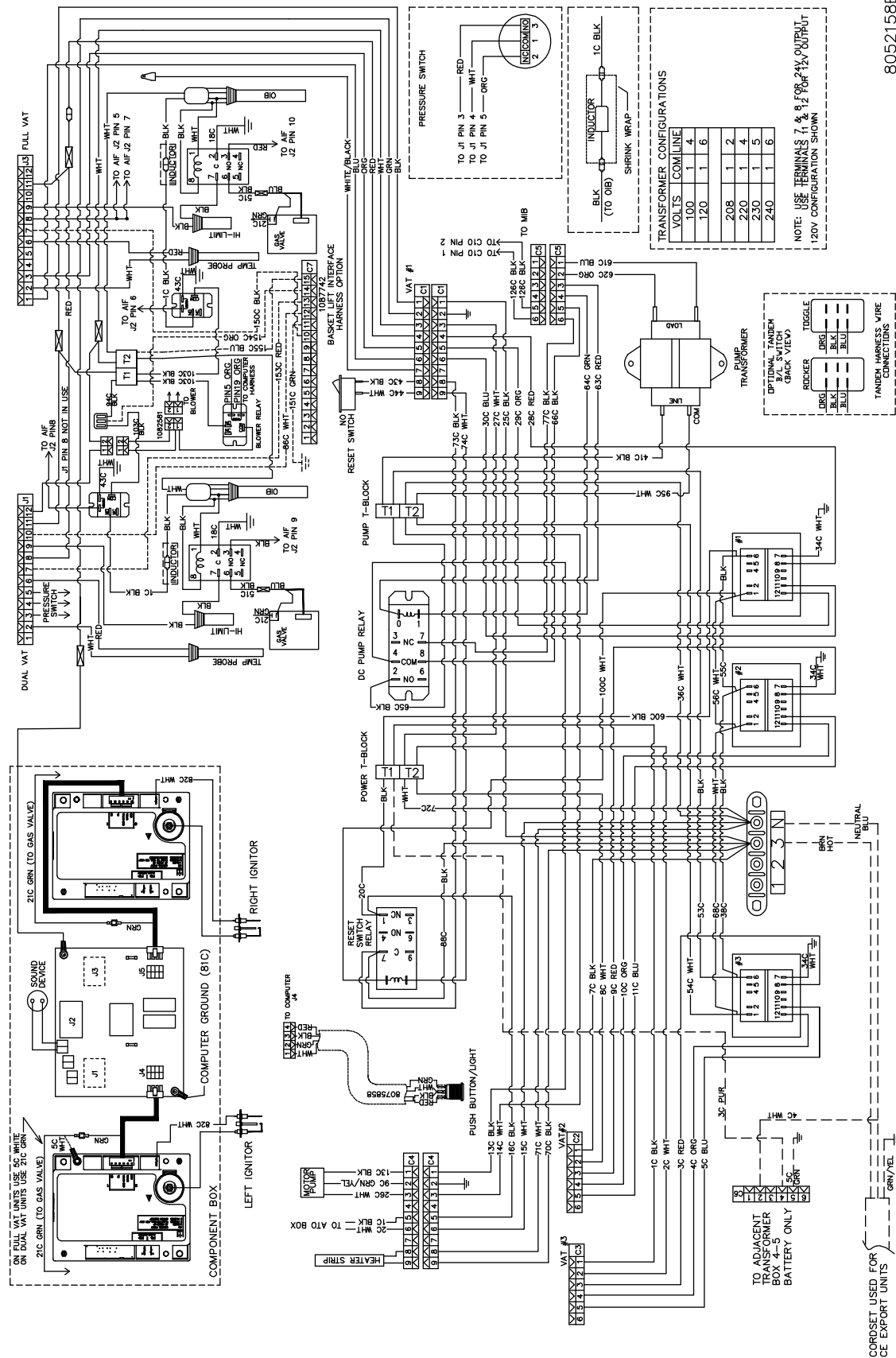

8052158B

1.21.8 Main FQG 330/530 Australia with Solid Shortening

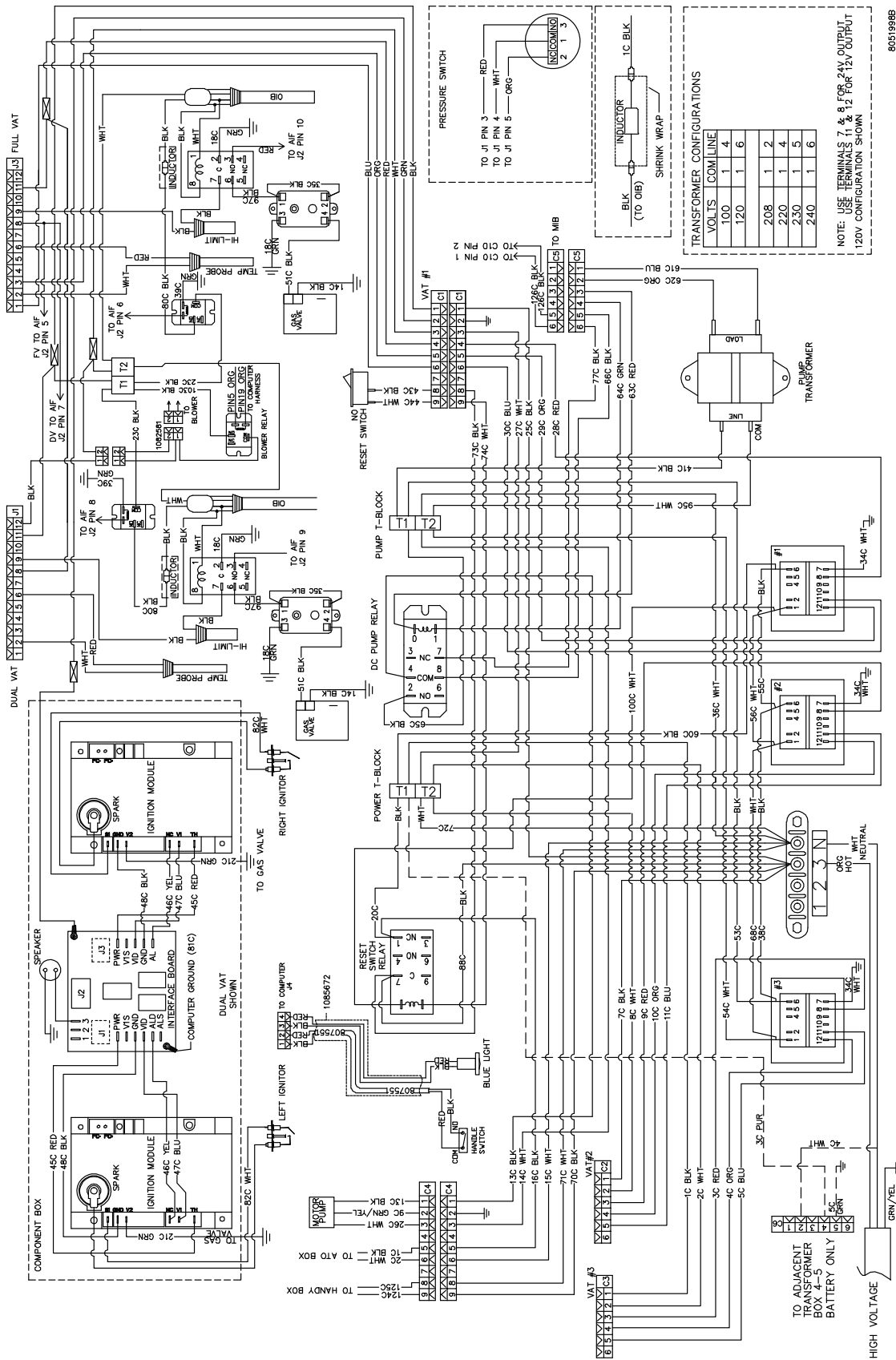

8051988B

1.21.9 Transformer / Filter Box 430/530

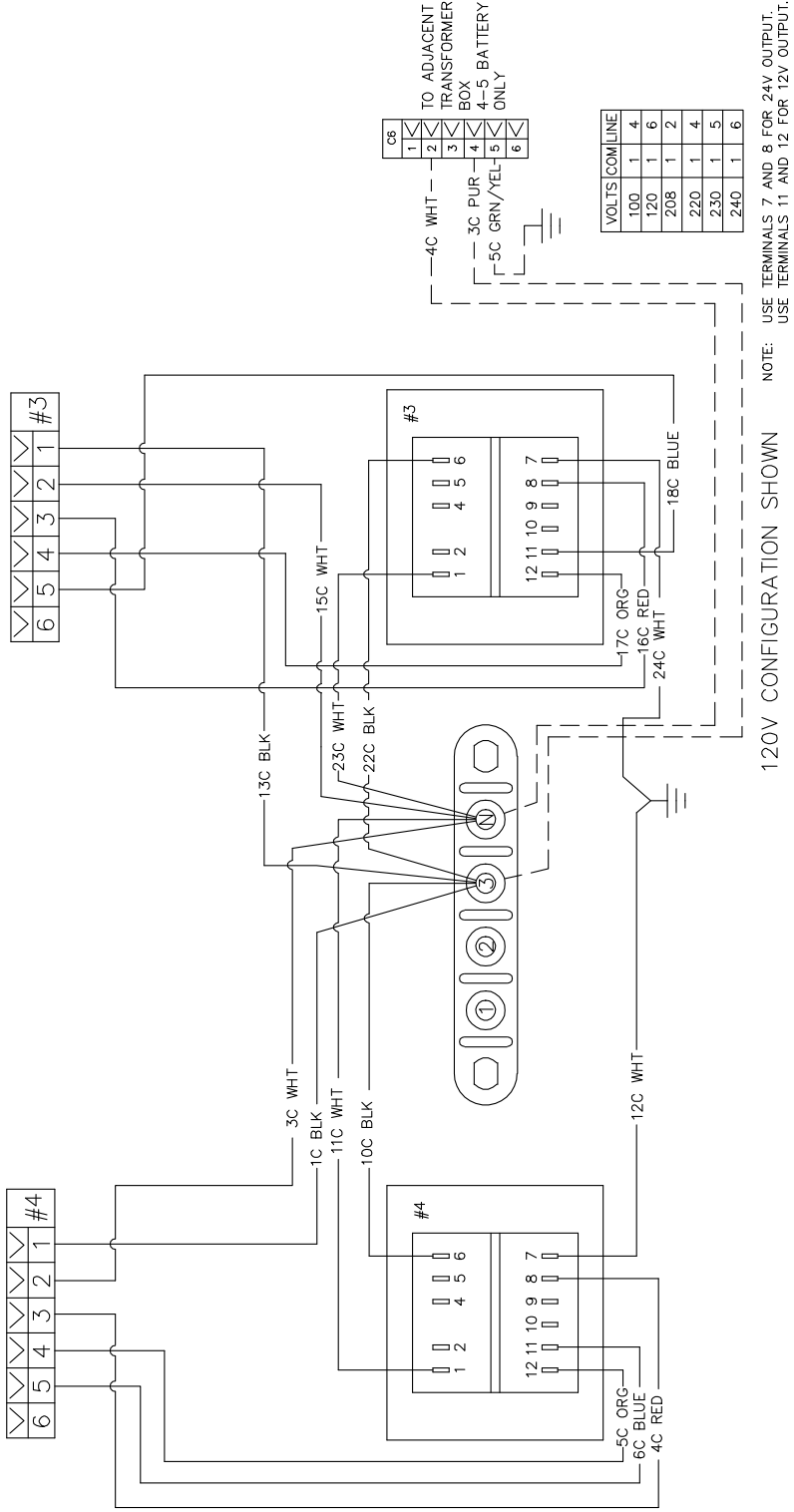

8051977A

1.22 Simplified Wiring Diagrams

1.22.1 FilterQuick™ FQG30 Series Simplified Wiring with Push Pull Handles

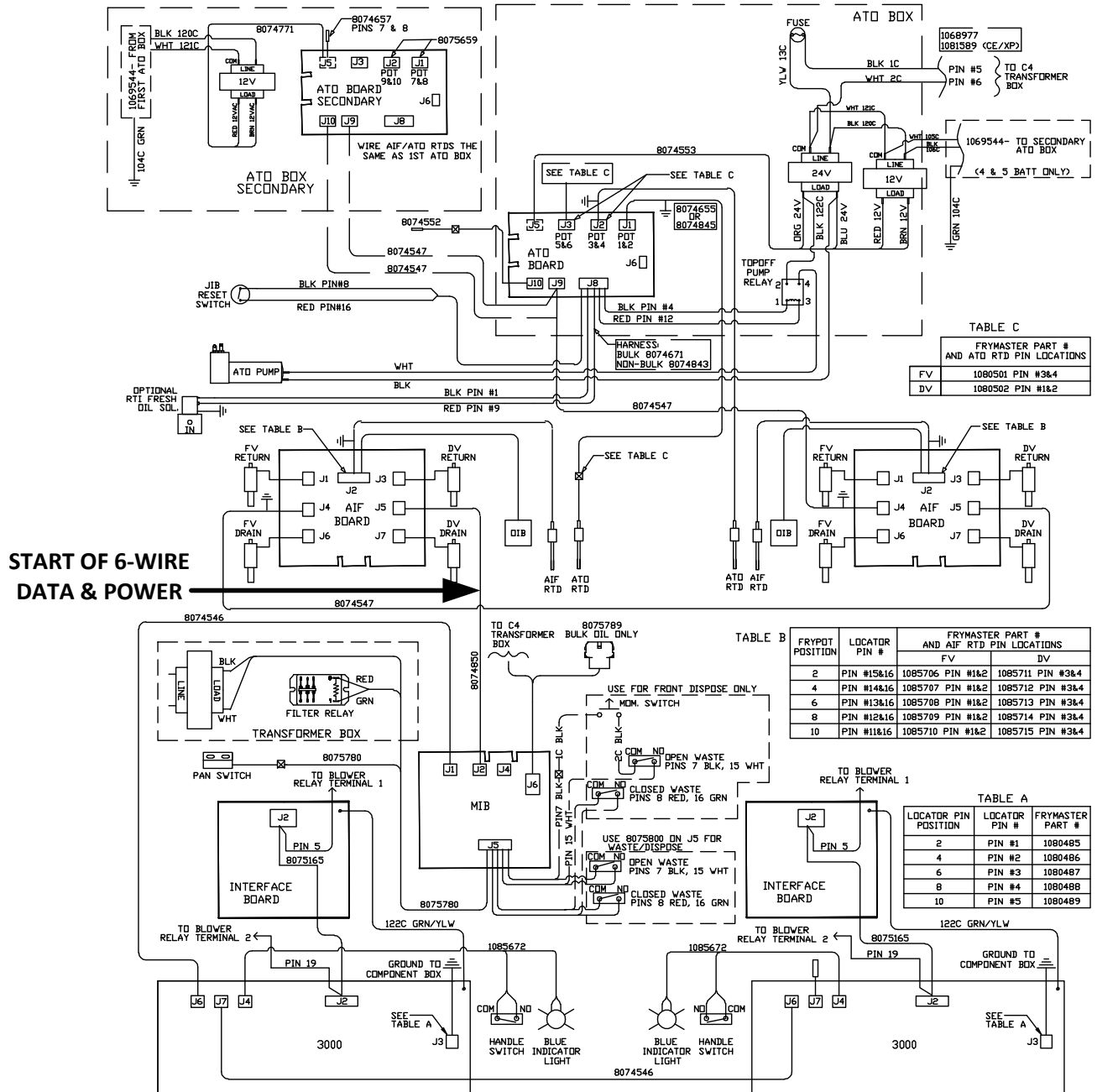

8051978D

1.22.2 FilterQuick™ FQG30 Series Simplified Wiring with Push Buttons

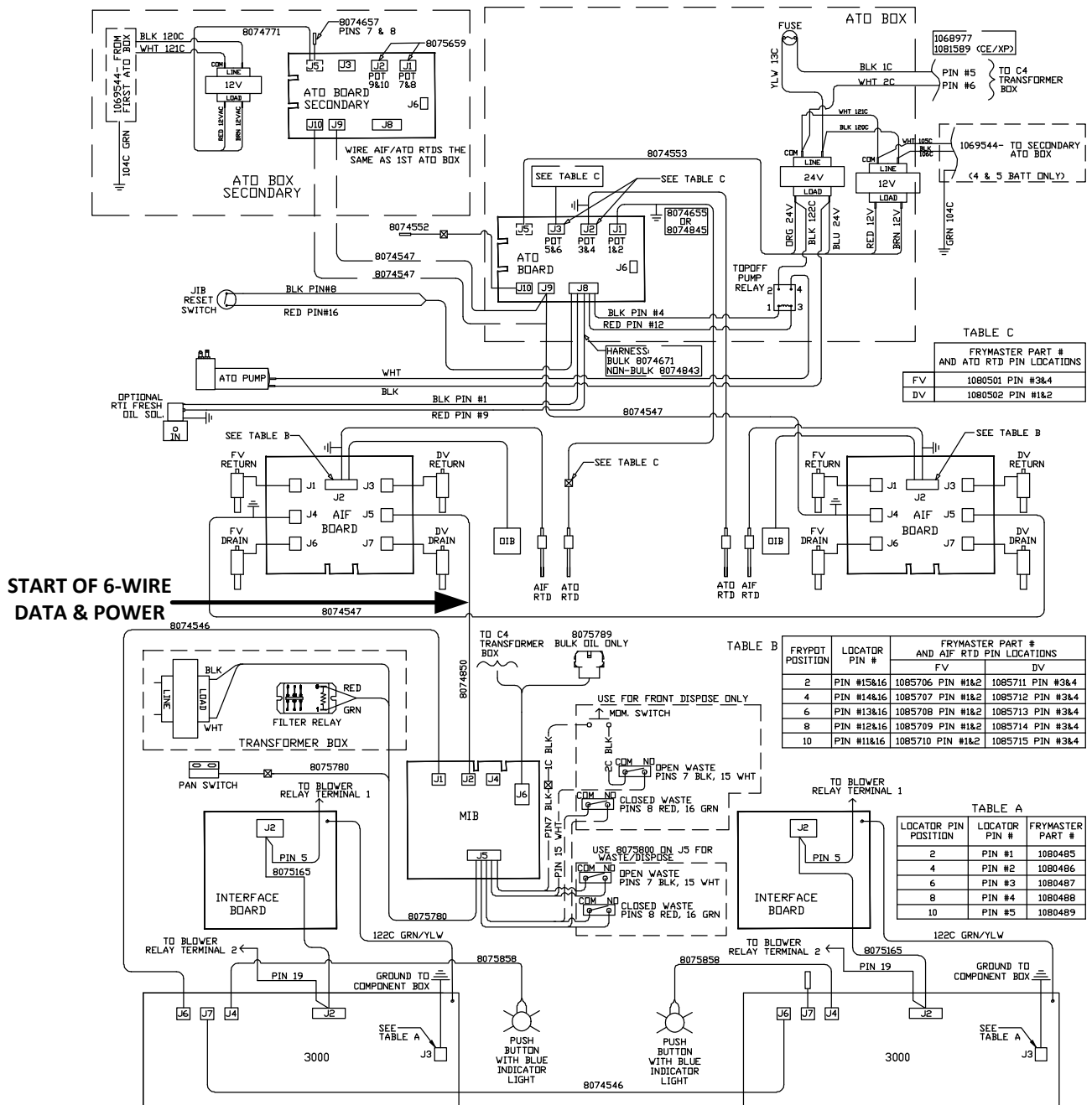

8052035A

1.22.3 FilterQuick™ FQG30 Series Data Network Flowchart

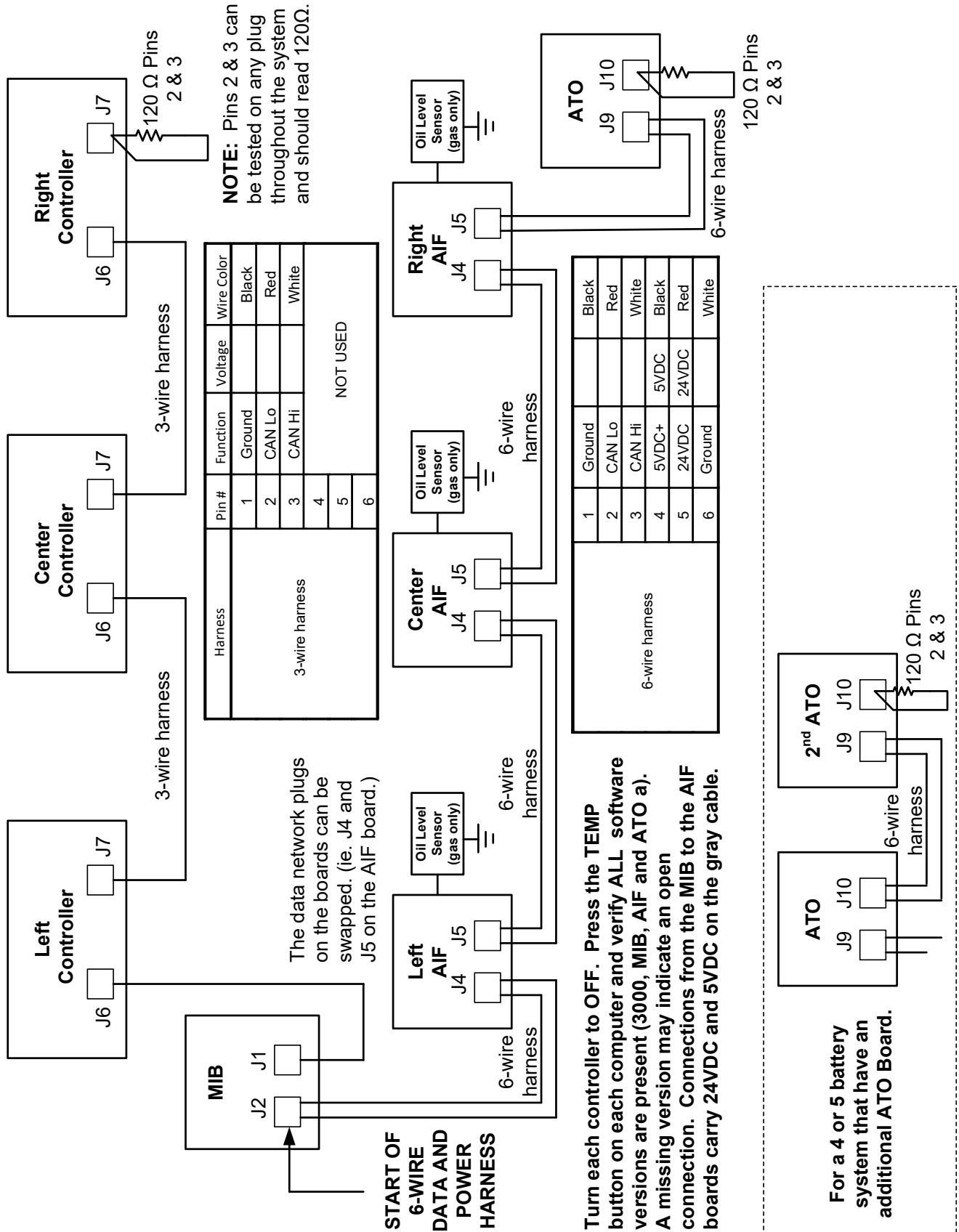

1.23 Alternate 7 sec. Time Delay Relay Wiring Diagrams PN 807-4934 220V-250V (Intl. Units), PN 807-4812 120V (US, Canada & Mexico)

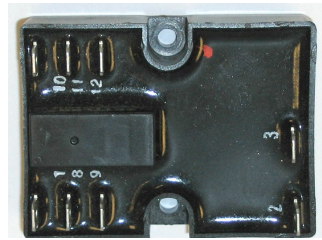
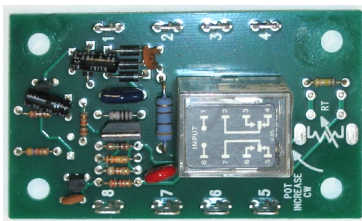
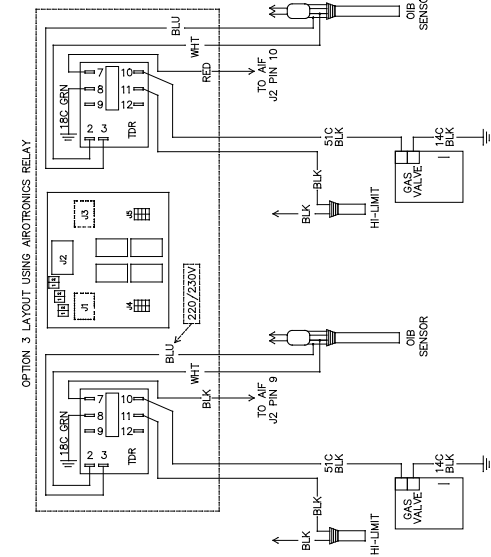
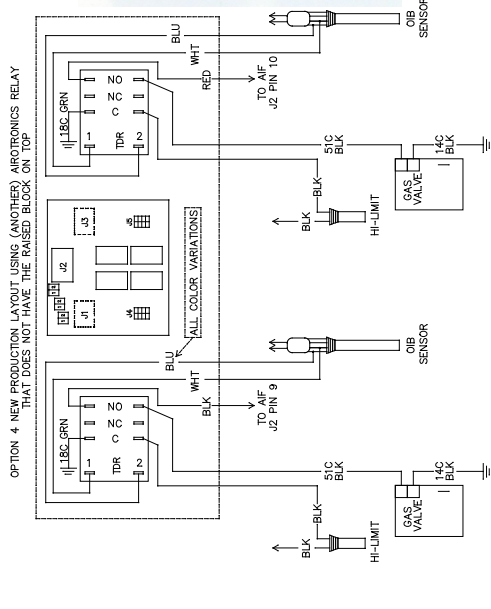
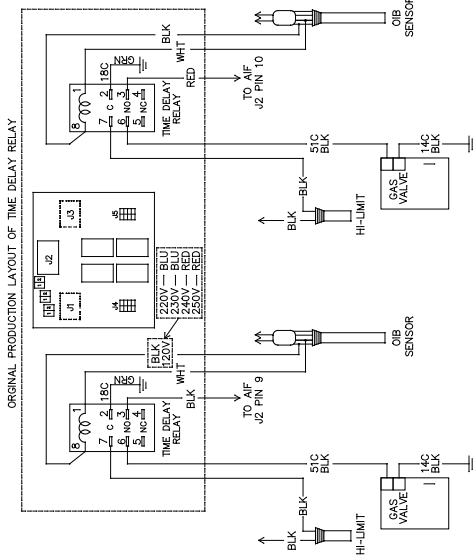
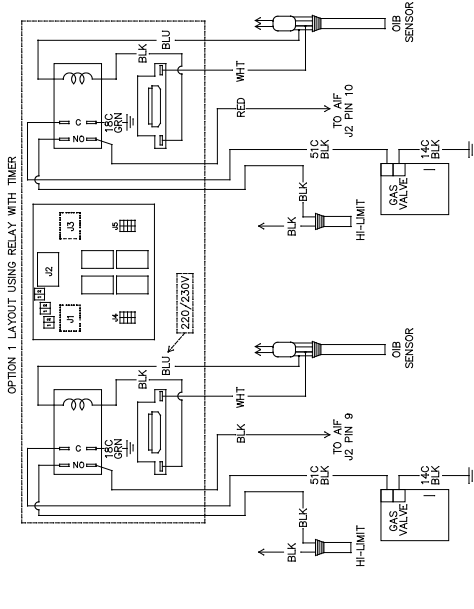
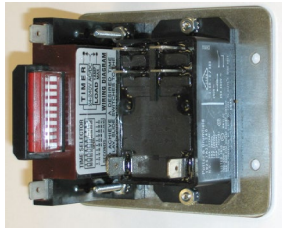

RELAY ORIENTATION MAY BE DIFFERENT IN ACTUAL ASSEMBLY

1.24 Shortening Melting Unit Wiring Diagram

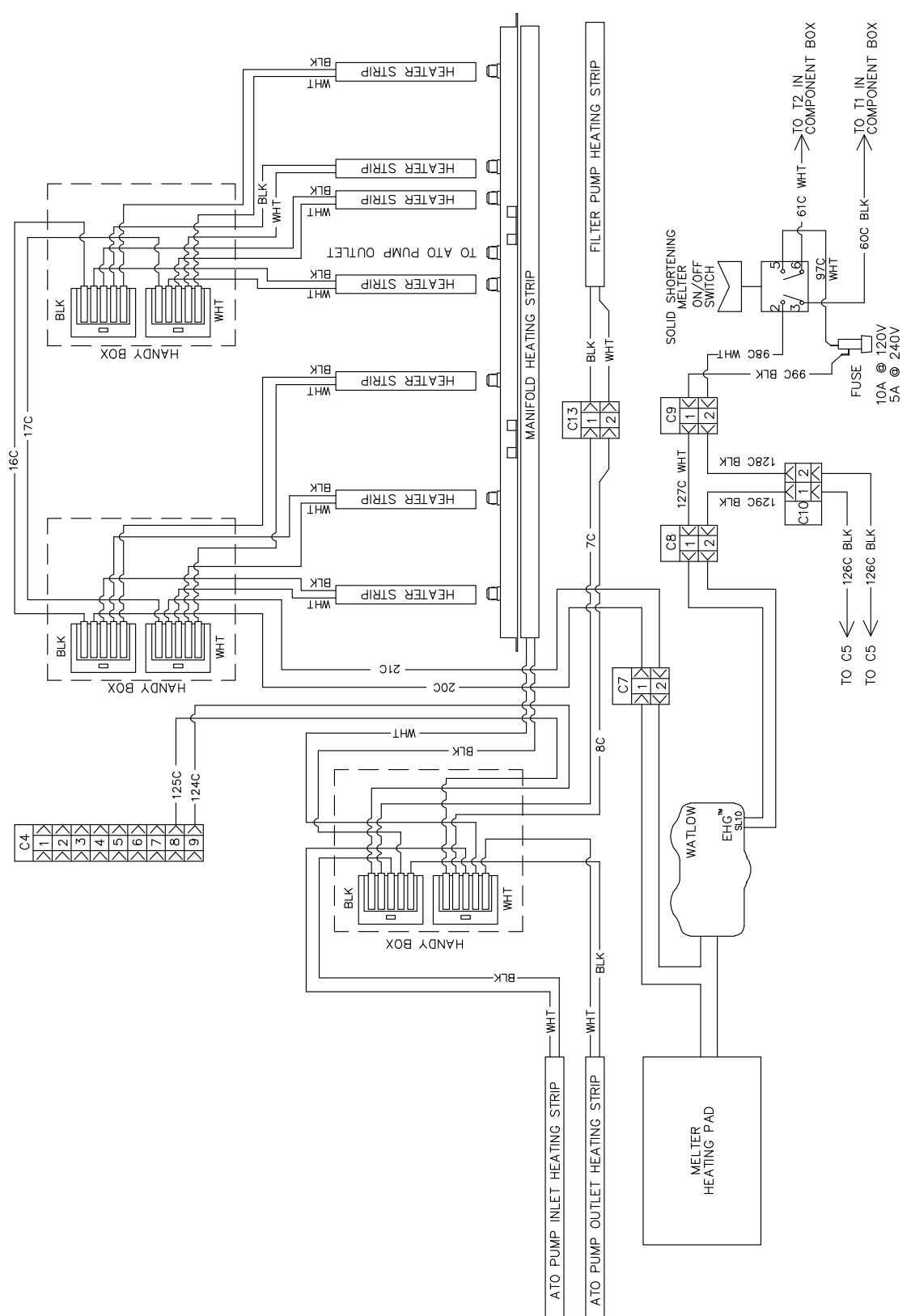

8051988A

1.25 Modular Basket Lift Wiring Diagram 100-120V

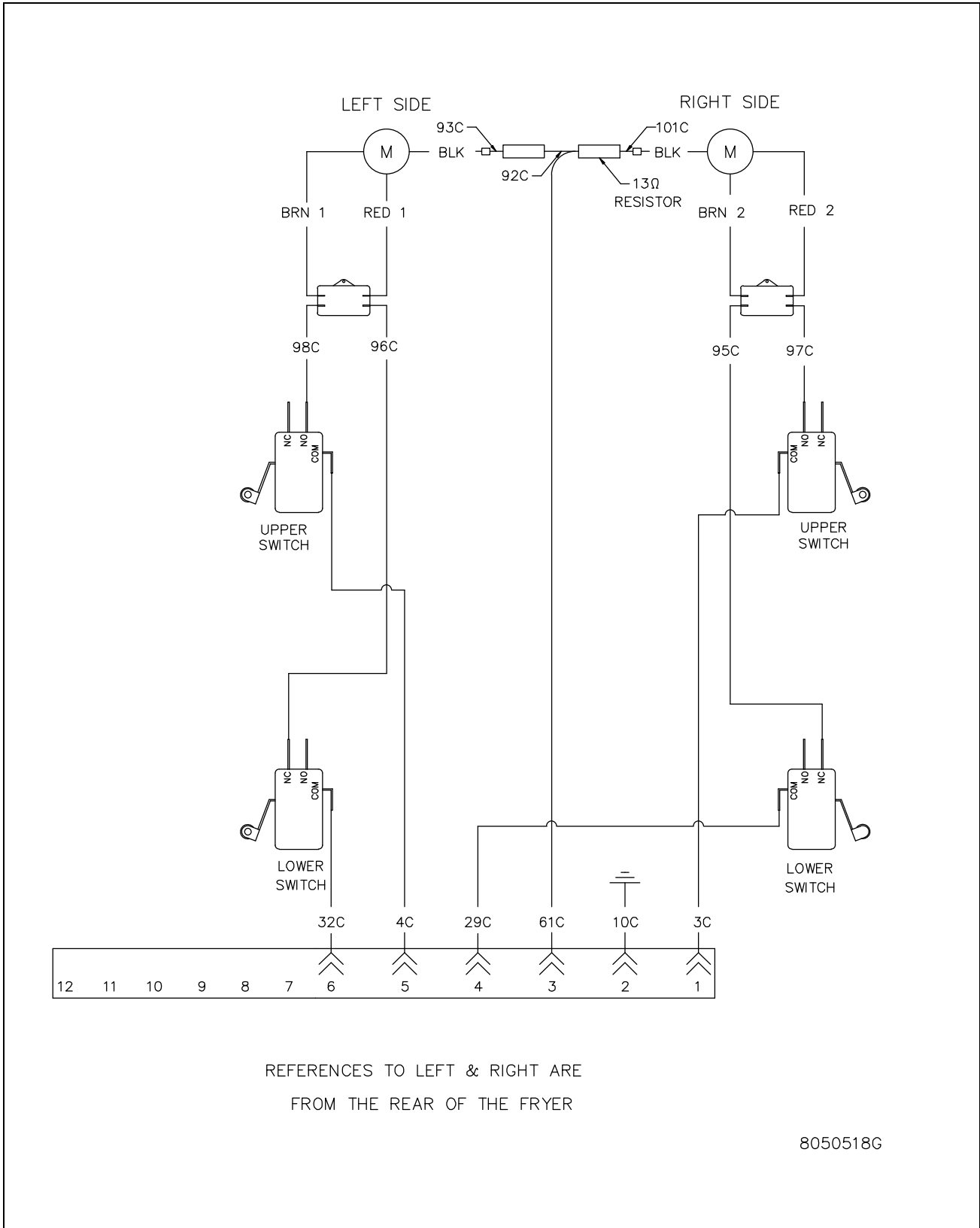

1.26 Modular Basket Lift Wiring Diagram 208-250V – Prior to 1706

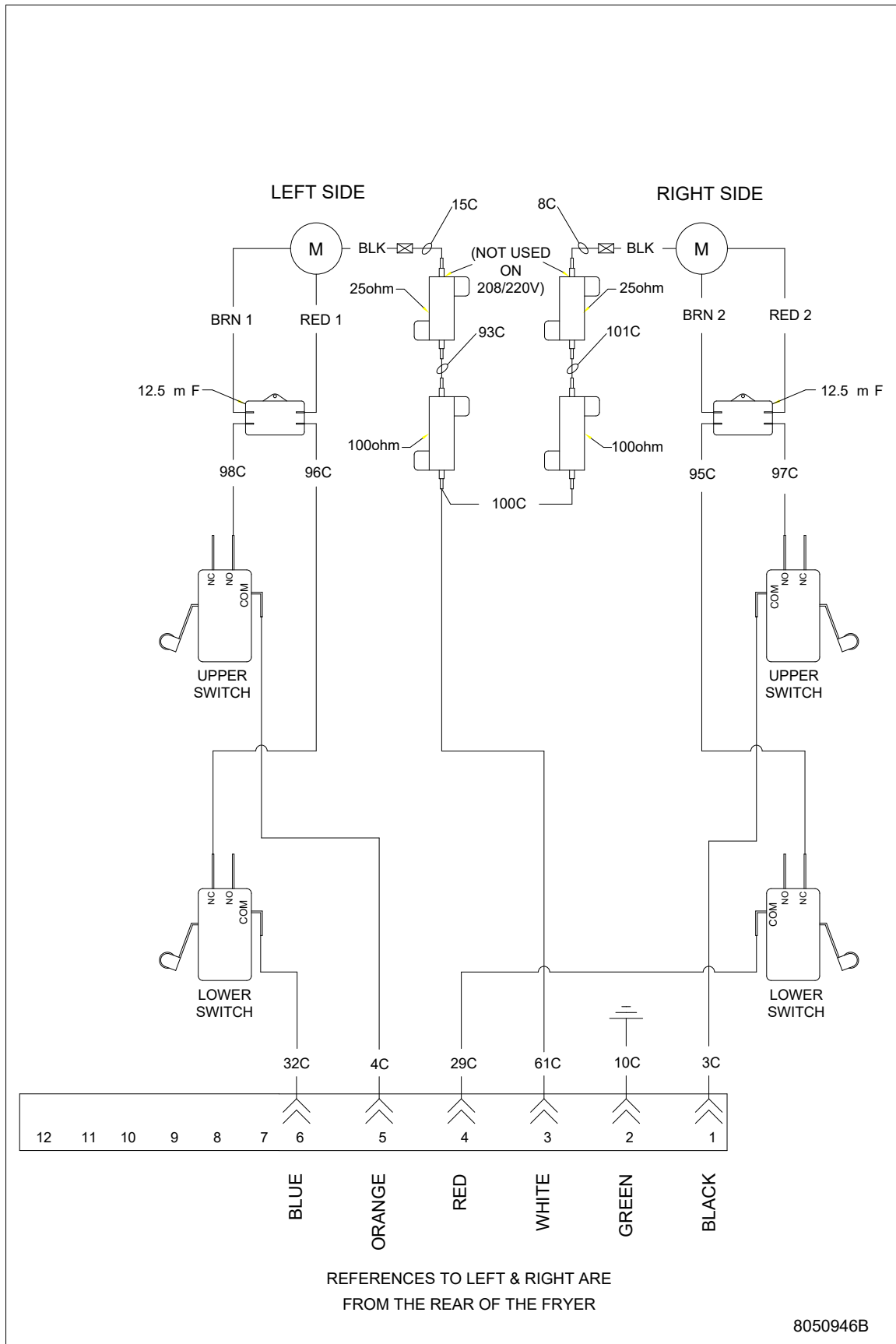

1.27 Modular Basket Lift Wiring Diagram 208-250V – After 1706

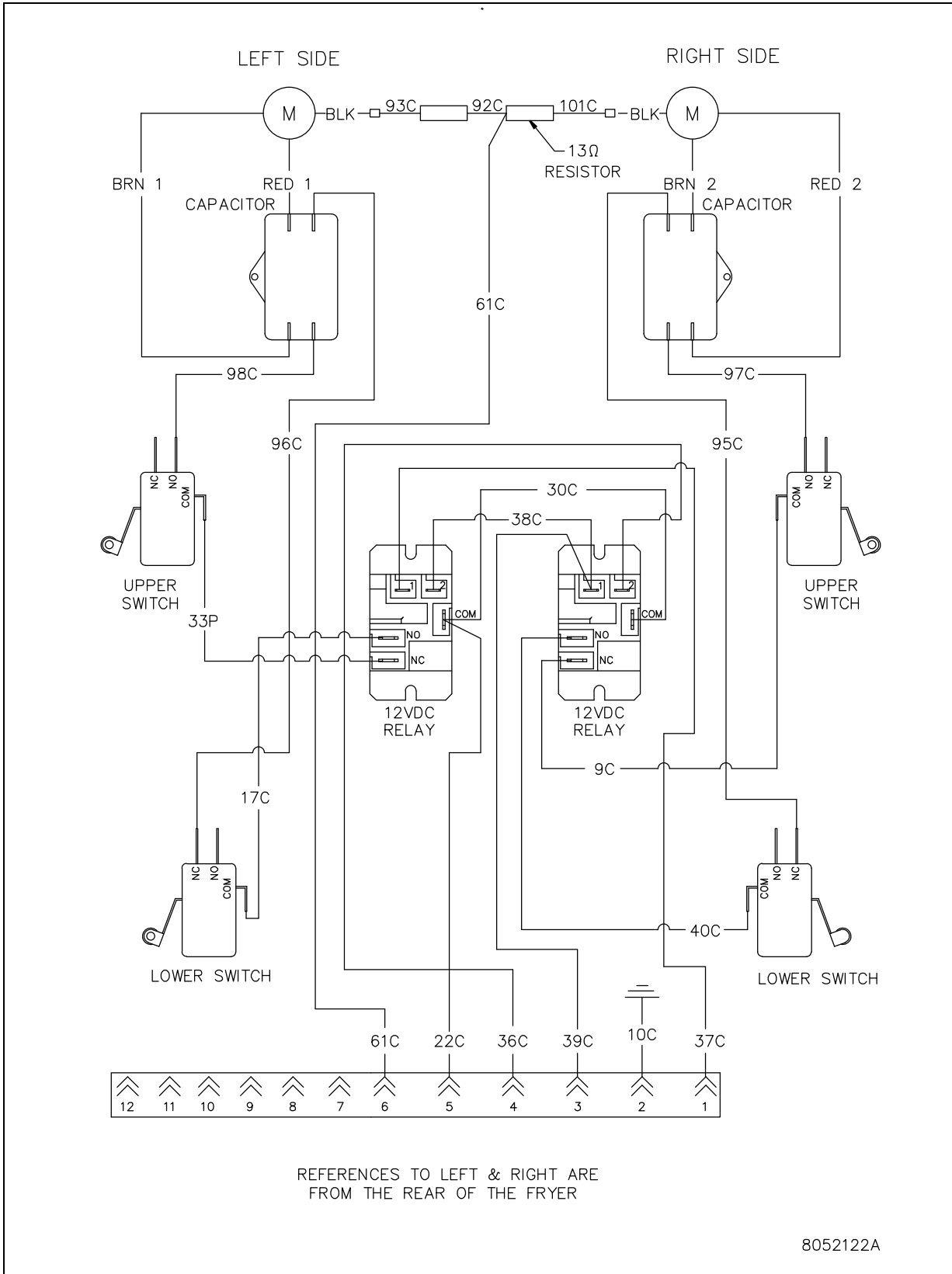

1.28 Basket Lift Interface Harness

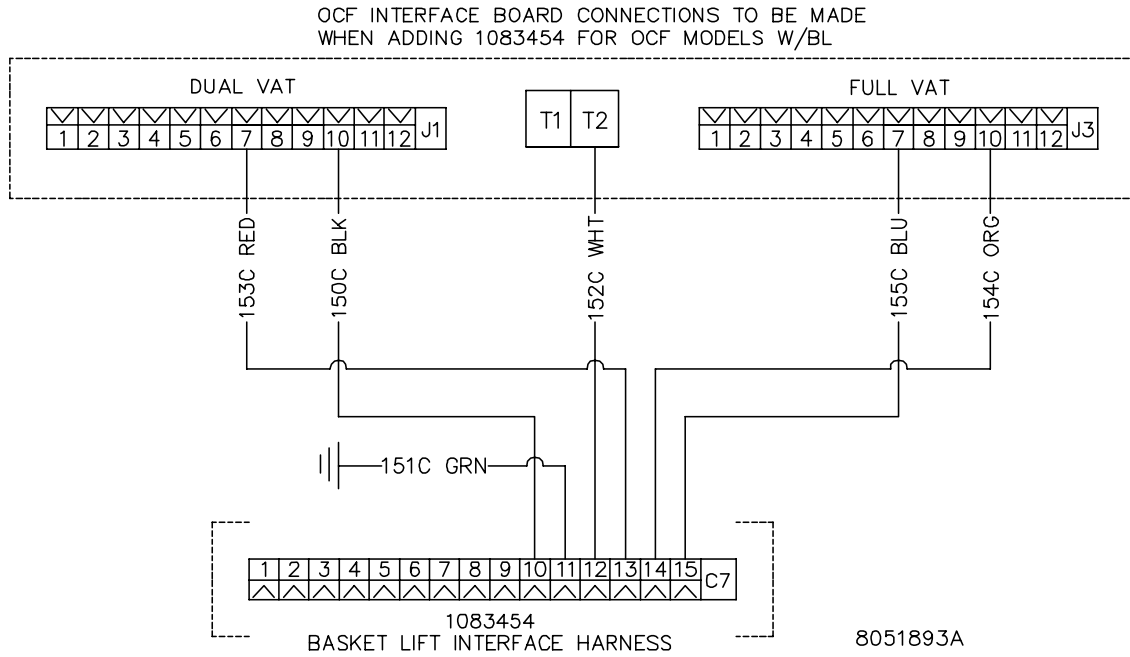

THIS PAGE INTENTIONALLY LEFT BLANK

Frymaster[®]

FRYMASTER
8700 LINE AVENUE, SHREVEPORT, LA 71106-6800

800-551-8633
318-865-1711
WWW.FRYMASTER.COM
EMAIL: FRYSERVICE@WELBILT.COM



Welbilt offers fully-integrated kitchen systems. Welbilt's portfolio of award-winning brands includes Cleveland™, Convotherm®, Crystal Tips®, Dean®, Delfield®, Fabristeel®, Frymaster®, Garland®, Inducs®, Koldtech®, Kolpak®, Lincoln®, McCann's™, Merco®, Merrychef®, Multiplex®, RDI®, SerVend™, SunFire®, U.S. Range™, and WMaxx™. Supported by service brands: FitKitchen®, kitchen systems; and KitchenConnect®, cloud-based open platform.

Bringing innovation to the table • welbilt.com

©2023 Frymaster LLC. except where explicitly stated otherwise. All rights reserved. Continuing product improvement may necessitate change of specifications without notice.

Part Number FRY_SM_8197109 10/2023