

Frymaster®

We Fit the Way You Fry™

FilterQuick™ FQG30U-easyTouch® Taco Bell Gas Fryer

Installation, Operation and Maintenance Manual

This manual is updated as new information and models are released. Visit our website for the latest manual.



FOR YOUR SAFETY

Do Not Store or use gasoline or other flammable vapors and liquids in the vicinity of this or any other appliance.

⚠ CAUTION

READ THE INSTRUCTIONS BEFORE USING THE FRYER.

Read these instructions for use carefully so as to familiarize yourself with the appliance before connecting it to its gas supply.

Keep these instructions for future reference.



8 1 9 7 4 7 6

Part Number: FRY_IOM_8197476 02/2024

Original Instructions



WELBILT®

NOTICE

IF, DURING THE WARRANTY PERIOD, THE CUSTOMER USES A PART FOR THIS FRYMASTER DEAN EQUIPMENT OTHER THAN AN UNMODIFIED NEW OR RECYCLED PART PURCHASED DIRECTLY FROM FRYMASTER DEAN, OR ANY OF ITS AUTHORIZED SERVICERS, AND/OR THE PART BEING USED IS MODIFIED FROM ITS ORIGINAL CONFIGURATION, THIS WARRANTY WILL BE VOID. FURTHER, FRYMASTER DEAN AND ITS AFFILIATES WILL NOT BE LIABLE FOR ANY CLAIMS, DAMAGES OR EXPENSES INCURRED BY THE CUSTOMER WHICH ARISE DIRECTLY OR INDIRECTLY, IN WHOLE OR IN PART, DUE TO THE INSTALLATION OF ANY MODIFIED PART AND/OR PART RECEIVED FROM AN UNAUTHORIZED SERVICER.

NOTICE

This appliance is intended for professional use only and is to be operated by qualified personnel only. A Frymaster Factory Authorized Servicer (FAS) or other qualified professional should perform installation, maintenance, and repairs. Installation, maintenance, or repairs by unqualified personnel may void the manufacturer's warranty. See Chapter 1 of this manual for definitions of qualified personnel.

NOTICE

This equipment must be installed in accordance with the appropriate national and local codes of the country and/or region in which the appliance is installed. For the United States and Canada these are the National Fuel Gas Code, ANSI Z233.1/NFPA 54, or the Natural Gas and Propane Installation Code, CSA B149.1. See NATIONAL CODE REQUIREMENTS in Chapter 2 of this manual for specifics.

The gas manifold of this appliance or of the battery of which it is a part must be connected to a gas appliance pressure regulator adjusted for the manifold pressure marked on the rating plate.

The appliance and its individual shutoff valve must be disconnected from the gas supply piping system during any pressure testing of that system at test pressures in excess of ½ psi (3.5 kPa/13.84 inches W.C.).

The appliance must be isolated from the gas supply piping system by closing its individual manual shutoff valve during any pressure testing of the gas supply piping system at test pressures equal to or less than ½ psi (3.5 kPa/13.84 inches W.C.).

NOTICE TO U.S. CUSTOMERS

This equipment is to be installed in compliance with the basic plumbing code of the Building Officials and Code Administrators International, Inc. (BOCA) and the Food Service Sanitation Manual of the U.S. Food and Drug Administration.

 **DANGER**

Instructions to be followed in the event the operator smells gas or otherwise detects a gas leak must be posted in a prominent location. This information can be obtained from the local gas company or gas supplier.

 **WARNING**

Improper installation, adjustment, maintenance or service, and unauthorized alterations or modifications can cause property damage, injury, or death. Read the installation, operating, and service instructions thoroughly before installing or servicing this equipment. Only qualified service personnel may convert this appliance to use a gas other than that for which it was originally configured.

 **FOR YOUR SAFETY**

Do not store or use gasoline or other flammable liquids or vapors in the vicinity of this or any other appliance.

 **DANGER**

No structural material on the fryer should be altered or removed to accommodate placement of the fryer under a hood. Questions? Call the Frymaster Dean Service Hotline at 1-800-551-8633.

 **WARNING**

After installation of a gas fryer and after any maintenance to the gas system of a gas fryer-manifold, valve, burners, etc. - check for gas leaks at all connections. Apply a thick soapy solution to all connections and ensure there are no bubbles. There should be no smell of gas.

NOTICE

Drawings and photos used in this manual are intended to illustrate operational, cleaning and technical procedures and may not conform to onsite management operational procedures.

NOTICE

U.S.

This device complies with Part 15 of the FCC rules. Operation is subject to the following two conditions: 1) This device may not cause harmful interference, and 2) This device must accept any interference received, including interference that may cause undesired operation. While this device is a verified Class A device, it has been shown to meet the Class B limits.

CANADA

This digital apparatus does not exceed the Class A or B limits for radio noise emissions as set out by the ICES-003 standard of the Canadian Department of Communications.

NOTICE

The Commonwealth of Massachusetts requires any and all gas products to be installed by a licensed plumber or pipe fitter.

 **DANGER**

Adequate means must be provided to limit the movement of the appliance without depending upon the gas line connector and the quick-disconnect device or its associated piping to limit the appliance movement.

All fryers equipped with casters must be stabilized by installing restraining chains. If a flexible gas line is used, an additional restraining cable must be connected at all times when the fryer is in use.

All fryers equipped with casters must be installed using a connector that complies with the Standard for Connectors for Moveable Gas Appliances, ANSI Z21.69 or CSA 6.16, and a quick-disconnect device that complies with the Standard for Quick-Disconnect Devices for Use with Gas Fuel, ANSI Z21.41 or CSA 6.9.

NOTICE

No warranty is provided for any Frymaster fryer used in a mobile or marine installation or concession. Warranty protection is only offered for fryers installed in accordance with the procedures described in this manual. Mobile, marine or concession conditions of this fryer should be avoided to ensure optimum performance.

 **DANGER**

The front ledge of the fryer is not a step! Do not stand on the fryer. Serious injury can result from slips or contact with the hot oil.

 **DANGER**

Do not spray aerosols in the vicinity of this appliance while it is in operation.

 **DANGER**

When installed, this appliance must be electrically grounded in accordance with local codes, or in the absence of local codes, with the National Electrical Code, ANSI/NFPA 70, the Canadian Electrical Code, CSA C22.2 applicable, or the appropriate national code of the country in which installed.

 **DANGER**

When installed, this appliance must conform with local codes, or in the absence of local codes, with the National Fuel Gas Code, ANSI Z223.1/NFPA54, or the Natural Gas and Propane Installation Code, CSA B149.1 as applicable or the appropriate national code of the country in which installed.

 **DANGER**

The crumb tray in fryers equipped with a filter system **MUST** be emptied into a fireproof container at the end of frying operations each day. Some food particles can spontaneously combust if left soaking in certain shortening material.

 **DANGER**

When using a sediment basket, it **MUST** be removed and emptied prior and during each filtration. Some food particles can spontaneously combust if left soaking in certain shortening material.

 **WARNING**

Do not bang fry baskets or other utensils on the fryer's joiner strip. The strip is present to seal the joint between the fry vessels. Banging fry baskets on the strip to dislodge shortening will distort the strip, adversely affecting its fit. It is designed for a tight fit and should only be removed for cleaning.

 **WARNING**

To ensure the safe and efficient operation of the fryer and hood, the electrical plug for the 120-volt line, must be fully engaged and locked in its pin and sleeve socket.

NOTICE

The instructions in this manual for using a bulk oil system for filling and discarding oil are for an RTI and Frontline. These instructions may not be applicable to other bulk oil systems.

NOTICE

This appliance is intended to be used for commercial applications, for example in kitchens of restaurants, canteens, hospitals and in commercial enterprises such as bakeries, butcheries, etc., but not for continuous mass production of food.

NOTICE

The appliance must be installed and used in such a way that any water cannot contact the fat or oil.

 **DANGER**

This appliance must be connected to a power supply having the same voltage and phase as specified on the rating plate located on the inside of the appliance door.

 **WARNING**

Use caution and wear appropriate safety equipment to avoid contact with hot oil or surfaces that may cause severe burns or injury.

 **WARNING**

Do not block the area around the base or under the fryers.

 **WARNING**

This appliance is not intended for use by children under the age of 16 or persons with reduced physical, sensory or mental capabilities, or lack of experience and knowledge, unless they have been given supervision concerning use of the appliance by a person responsible for their safety. Do not allow children to play with this appliance.

 **WARNING**

If the electrical power supply cord is damaged, it must be replaced by a Frymaster Factory Authorized Servicer or a similarly qualified person in order to avoid a hazard.

 **WARNING**

NEVER drain boil out or cleaning solution into a shortening disposal unit (SDU), a built-in filtration unit, a portable filter unit. These units are not intended for this purpose and will be damaged by the solution and void the warranty.

 **DANGER**

Prior to movement, testing, maintenance and any repair on your Frymaster fryer; disconnect ALL electrical power cords from the electrical power supply.

 **WARNING**

Operation, installation, and servicing of this product may expose you to chemicals/products including [Bisphenol A (BPA), glass wool or ceramic fibers, and crystalline silica], which is [are] known to the State of California to cause cancer, birth defects or other reproductive harm. For more information go to www.P65Warnings.ca.gov.



WARNING

Do not leave the fryer unattended during use.



WARNING

Use caution when dropping wet food or water into the hot oil. It may cause spattering of the oil, which may cause severe burns



WARNING

Do not overfill the frypot to avoid overflow of hot oil that may cause severe burns, slipping and falling.



WARNING

Use caution and wear appropriate safety equipment when adding oil to the fryer, to prevent splashing of hot oil, which may cause severe burns.



WARNING

The OQS (Oil Quality Sensor) may be damaged by the following:

1. Incorrect assembly of the filter pan allowing Magnesol or other filter powders under the filter paper.
2. Failure to use filter paper or pads.
3. Torn filter paper or pads.
4. Pumping water, boil out solution or other cleaners through the OQS sensor.
5. Using high pressure to clear the sensor.

Failure to follow these guidelines may result in high replacement costs and void the warranty.

Table of Contents

| | | |
|------------------|--------------------------------------|------------|
| Section 1 | Introduction..... | 1-1 |
| Section 2 | Installation..... | 2-1 |
| Section 3 | Operation Instructions..... | 3-1 |
| Section 4 | Preventative Maintenance..... | 6-1 |
| Section 5 | Operator Troubleshooting..... | 7-1 |
| Section A | Bulk Oil Instructions..... | A-1 |

FILTERQUICK™ FQG30-T TACO BELL GAS FRYER

CHAPTER 1: INTRODUCTION

NOTE: The Frymaster FQG30-T fryer requires a start-up, demonstration and training before normal restaurant operations can begin.

1.1 General

Read the instructions in this manual thoroughly before attempting to operate this equipment. This manual covers all configurations of models and FQG30-T fryers. Models designated with FQG30-T are equipped with built-in filtration systems. The fryers in this model family have most parts in common, and when discussed as a group, will be referred to as FQG30-T fryers.

The FQG30-T fryers feature a low oil volume frypot, top-off (manual or optional auto), automatic filtration and a touch screen. The design incorporates a large round drain which ensures that fries and other debris will be washed into the filter pan. The FQG30-T fryers are controlled with an FQ4000 touchscreen controller. Fryers in this series come in full- or split-vat arrangements, and can be purchased in batteries of up to five vats.

FQG30-T high-efficiency gas fryers employ a unique infrared burner system that uses up to 43% less energy to cook the same volume as conventional open-burner fryers.

FQG30-T gas fryers are of an open-frypot design with no tubes, which makes cleaning the stainless frypot quick and easy.

Heating is supplied by a pair of infrared burner assemblies mounted on each side of the frypot. A dedicated blower mounted on the front of the frypot supplies combustion air for the burners. FQG30-T Gas fryers can be configured for natural gas or propane (LP) gas, as required by the customer.

Each frypot is equipped with a temperature probe for precise temperature control.

All fryers in this series require an external source of AC electrical power. Units can be configured for voltages ranging from 100 VAC to 250 VAC.

FQG30-T fryers are shipped completely assembled. All fryers are shipped with a package of standard accessories. Each fryer is adjusted, tested, and inspected at the factory before crating for shipment.

This appliance is only for professional use and shall be used by qualified personnel only, as defined in Section 1.6.

1.2 Safety Information

Before attempting to operate your unit, read the instructions in this manual thoroughly. Throughout this manual, you will find notations enclosed in double-bordered boxes similar to the ones that follow.

 **CAUTION**

CAUTION boxes contain information about actions or conditions that *may cause or result in a malfunction of your system.*

 **WARNING**

WARNING boxes contain information about actions or conditions that *may cause or result in damage to your system,* and which may cause your system to malfunction.

 **DANGER**

DANGER boxes contain information about actions or conditions that *may cause or result in injury to personnel,* and which may cause damage to your system and/or cause your system to malfunction.

Your fryer is equipped with automatic safety features:

1. High-temperature detection shuts off gas to the burner assembly should the controlling thermostat fail.
2. A safety circuit on units with filter systems prevents burner ignition with the drain valve open.

The controller is equipped with a lithium battery. Replace battery with Panasonic CR2032 3V lithium battery, part number 8074674 only. Use of another battery may present a risk of fire or explosion. The battery can be purchased from your Factory Authorized Servicer.

 **CAUTION**

Battery may explode if mistreated. Do not recharge, disassemble or dispose of in fire.

1.3 Information for the FQ4000 Touchscreen Controllers FCC COMPLIANCE

This equipment has been tested and found to comply with the limits for a Class A digital device, pursuant to Part 15 of the FCC rules. While this device is a verified Class A device, it has been shown to meet the Class B limits. These limits are designed to provide reasonable protection against harmful interference when the equipment is operated in a commercial environment. This equipment generate, uses and can radiate radio frequency energy and, if not installed and used in accordance with the instruction manual, may cause harmful interference to radio communications. Operation of the equipment in a residential area is likely to cause harmful interference in which case the user will be required to correct the interference at his own expense.

The user is cautioned that any changes or modifications not expressly approved by the party responsible for compliance could void the user's authority to operate the equipment.

If necessary, the user should consult the dealer or an experienced radio and television technician for additional suggestions.

The user may find the following booklet prepared by the Federal Communications Commission helpful: "How to Identify and Resolve Radio-TV Interference Problems". This booklet is available from the U.S. Government Printing Office, Washington, DC 20402, Stock No. 004-000-00345-4.

1.4 European Community (CE) Specific Information

The European Community (CE) has established certain specific standards regarding equipment of this type. Whenever a conflict exists between CE and non-CE standards, the information or instructions concerned are identified by means of shadowed boxes.

1.5 Installation, Operating, and Service Personnel

Operating information for Frymaster equipment has been prepared for use by qualified and/or authorized personnel only, as defined in Section 1.6. **All installation and service on Frymaster equipment must be performed by qualified, certified, licensed, and/or authorized installation or service personnel, as defined in Section 1.6.**

1.6 Definitions

QUALIFIED AND/OR AUTHORIZED OPERATING PERSONNEL

Qualified/authorized operating personnel are those who have carefully read the information in this manual and have familiarized themselves with the equipment functions, or who have had previous experience with the operation of the equipment covered in this manual.

QUALIFIED INSTALLATION PERSONNEL

Qualified installation personnel are individuals, firms, corporations, and/or companies which, either in person or through a representative, are engaged in and are responsible for the installation of gas-fired appliances. Qualified personnel must be experienced in such work, be familiar with all gas precautions involved, and have complied with all requirements of applicable national and local codes.

QUALIFIED SERVICE PERSONNEL

Qualified service personnel are those who are familiar with Frymaster equipment and who have been authorized by Frymaster, L.L.C. to perform service on the equipment. All authorized service personnel are required to be equipped with a complete set of service and parts manuals, and to stock a minimum amount of parts for Frymaster equipment. A list of Frymaster Factory Authorized Servicers (FAS's) is located on the Frymaster website at www.frymaster.com. ***Failure to use qualified service personnel will void the Frymaster warranty on your equipment.***

1.7 Shipping Damage Claim Procedure

Your Frymaster equipment was carefully inspected and packed before leaving the factory. The transportation company assumes full responsibility for safe delivery upon its acceptance of the equipment for transport.

What to do if your equipment arrives damaged:

- 1. File a claim for damages immediately**, regardless of the extent of damages.
- 2. Inspect for and record all visible loss or damage**, and ensure that this information is noted on the freight bill or express receipt and is signed by the person making the delivery.

3. **Concealed loss or damage** that was unnoticed until the equipment was unpacked should be recorded and reported to the freight company or carrier **immediately** upon discovery. A concealed damage claim must be submitted within 5 days of the date of delivery. Ensure that the shipping container is retained for inspection.

Frymaster **DOES NOT ASSUME RESPONSIBILITY FOR DAMAGE OR LOSS INCURRED IN TRANSIT.**

1.8 Reading Model Numbers

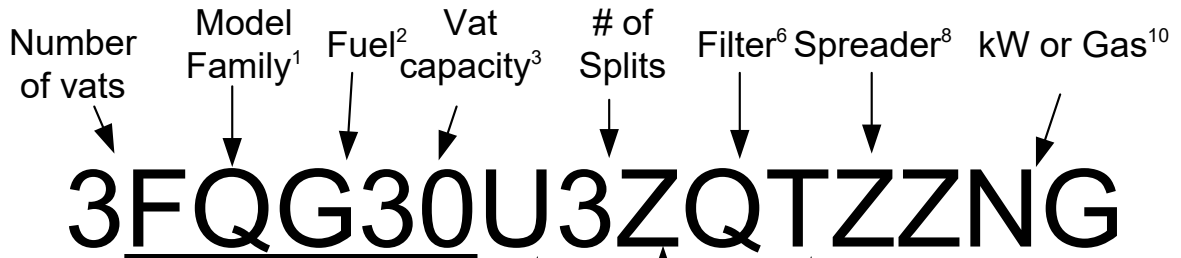

- 1 = FilterQuick
- 2 = E-electric or G-gas
- 3 = 30 lbs
- 4 = U for open
- 5 = L-left of filter; R-right of filter; M-Middle; X-Mixed; Z-all
- 6 = Q-Semi-Auto w/ ATO
- 7 = Touch Screen
- 8 = S-Spreader; Z-none
- 9 = B-Basket Lift; Z-none
- 10 = Kilowatts -14, 17, 22kW; Gas-NG (Natural), PG(Propane), BG(Butane), LG(LPMix)

1.9 Parts Ordering and Service Information

For non-routine maintenance or repairs, or for service information, contact your local Frymaster Authorized Servicer (FAS). In order to assist you quickly, the Frymaster Authorized Servicer (FAS) or Service Department representative requires certain information about your equipment. Most of this information is printed on a data plate affixed to the inside of the fryer door. Part numbers are found in the Parts Manual. Parts orders may be placed directly with your local FAS or distributor. A list of Frymaster Factory Authorized Servicers (FAS's) is located on the Frymaster website at www.frymaster.com. If you do not have access to this list, contact the Frymaster Service Department at 1-800-551-8633 or 1-318-865-1711.

Service information may be obtained by contacting your local FAS/Distributor. Service may also be obtained by calling the Frymaster Service Department at 1-800-551-8633 or 1-318-865-1711 or by email at fryservice@welbilt.com. When requesting service or ordering parts, please have the following information ready:

Model Number _____
Serial Number _____
Voltage _____
Type of Gas _____
Nature of the Problem _____

Item Part Number _____
Quantity Needed _____

In addition to the model number, serial number, and type of gas, please be prepared to describe the nature of the problem and have ready any other information that you think may be helpful in solving your problem.

RETAIN AND STORE THIS MANUAL IN A SAFE PLACE FOR FUTURE USE.

FILTERQUICK™ FQG30-T TACO BELL GAS FRYER

CHAPTER 2: INSTALLATION INSTRUCTIONS

2.1 General Installation Requirements

Proper installation is essential for the safe, efficient, trouble-free operation of this appliance.

Qualified, licensed, and/or authorized installation or service personnel, as defined in Section 1.6 of this manual, should perform all installation and service on Frymaster equipment.

Conversion of this appliance from one type of gas to another should only be performed by qualified, licensed, and/or authorized installation or service personnel as defined in Section 1.6 of this manual.

Failure to use qualified, licensed, and/or authorized installation or service personnel (as defined in Section 1.6 of this manual) to install, convert to another gas type or otherwise service this equipment will void the Frymaster warranty and may result in damage to the equipment or injury to personnel.

Where conflicts exist between instructions and information in this manual and local or national codes or regulations, installation and operation shall comply with the codes or regulations in force in the country in which the equipment is installed.

Service may be obtained by contacting your local Frymaster Dean Factory Authorized Servicer.

 DANGER

Building codes prohibit a fryer with its open tank of hot oil being installed beside an open flame of any type, including those of broilers and ranges.

Upon arrival, inspect the fryer carefully for visible or concealed damage. (See **Shipping Damage Claim Procedure** in Section 1.7 of this manual.)

2.1.1 Clearance and Ventilation

The fryer(s) must be installed with a 6" (150 mm) clearance at both sides and back when installed adjacent to combustible construction; no clearance is required when installed adjacent to noncombustible construction. A minimum of 24" (600 mm) clearance should be provided at the front of the fryer.

 WARNING

Do not block the area around the base or under the fryers.

 DANGER

No structural material on the fryer should be altered or removed to accommodate placement of the fryer under a hood. Questions? Call the Frymaster Dean Service Hotline at 1-800-551-8633.

One of the most important considerations of efficient fryer operation is ventilation. Make sure the fryer is installed so that products of combustion are removed efficiently, and that the kitchen ventilation system does not produce drafts that interfere with burner operation.

The fryer flue opening must not be placed close to the intake of the exhaust fan, and the fryer must never have its flue extended in a “chimney” fashion. An extended flue will change the combustion characteristics of the fryer, causing longer recovery time. It also frequently causes delayed ignition. To provide the airflow necessary for good combustion and burner operation, the areas surrounding the fryer front, sides, and rear must be kept clear and unobstructed.

 DANGER

This appliance must be installed with sufficient ventilation to prevent the occurrence of unacceptable concentrations of substances harmful to the health of personnel in the room in which it is installed.

Fryers must be installed in an area with an adequate air supply and adequate ventilation. Adequate distances must be maintained from the flue outlet of the fryer to the lower edge of the ventilation filter bank. Filters should be installed at an angle of 45°. Place a drip tray beneath the lowest edge of the filter. For U.S. installation, NFPA standard No. 96 states, “A minimum distance of 18 in. (450 mm) should be maintained between the flue outlet and the lower edge of the grease filter.” *Frymaster recommends that the minimum distance be 24 in. (600 mm) from the flue outlet to the bottom edge of the filter when the appliance consumes more than 120,000 BTU per hour.*

For installations in the United States, information on construction and installation of ventilating hoods can be found in the NFPA standard cited above. A copy of the standard may be obtained from the National Fire Protection Association, Battery March Park, Quincy, MA 02269.

2.1.2 National Code Requirements

The type of gas for which the fryer is equipped is stamped on the data plate attached to the inside of the fryer door. Connect a fryer stamped “NAT” only to natural gas, those stamped “PRO” only to propane gas, and those stamped “MFG” only to manufactured gas.

Installation shall be made with a gas connector that complies with national and local codes, and, where applicable, CE codes. Quick-disconnect devices, if used, shall likewise comply with national, local, and, if applicable, CE codes. In the absence of local codes, installation must conform to the national Fuel Gas Code, ANSI Z223.1/NFPA 54 or the Natural Gas and Propane Installation code, CSA B149.1, as applicable including:

1. The appliance and its individual shutoff valve must be disconnected from the gas supply piping system during any pressure testing of the system at test pressures in excess of ½ psi (3.5 kPa).
2. The appliance must be isolated from the gas supply piping system by closing its individual manual shutoff valve during any pressure testing of the gas supply piping system at test pressures equal to or less than ½ psi (3.5 kPa).

2.1.3 Electrical Grounding Requirements

All electrically operated appliances must be grounded in accordance with all applicable national and local codes, and, where applicable, CE codes. In the absence of local codes, the appliance must be grounded in accordance with National Electrical Code, ANSI/NFPA 70, or the Canadian Electrical Code, CSA C22.2, as applicable. All units (cord connected or permanently connected) should be connected to a grounded power supply system. A wiring diagram is located on the inside of the fryer door. Refer to the rating plate on the inside of the fryer door for proper voltages.

 **DANGER**

This appliance is equipped with a special (grounding) plug for your protection against electrical shock, and must be plugged directly into a properly grounded receptacle. Do not cut, remove, or otherwise bypass the grounding prong on this plug!

 **DANGER**

This appliance requires electrical power for operation. Place the gas control valve in the OFF position in case of a prolonged power outage. Do not attempt to operate this appliance during a power outage.

 **WARNING**

To ensure the safe and efficient operation of the fryer and hood, the electrical plug for the 120-volt line, which powers the hood, must be fully engaged and locked in its pin and sleeve socket.

2.1.4 Australian Requirements

To be installed in accordance with AS 5601, local authority, gas, electricity, and any other relevant statutory regulations.

If casters are fitted, the installation must comply with AS5601 and AS1869 requirements.

2.2 Caster Installation

On an appliance with casters; the installation shall be made with a connector that complies with the Standard for Moveable Gas Appliances, ANSI Z21.69 • CSA 6.16, and a quick disconnect device that

complies with the Standard for Quick-Disconnect Devices for Use With Gas Fuel, ANSI Z21.41 • CSA 6.9.

The front right caster may be locked with setscrews that may need to be loosened to move into place. Once in place, the caster setscrews can be locked with the caster wheel parallel to the fryer from front to back to ease moving the fryer in and out of the hood for cleaning and preventing the caster from hitting the oil reservoir.

2.3 Pre-Connection Preparations



DO NOT connect this appliance to the gas supply before completing each step in this section.

After the fryer has been positioned under the exhaust hood, ensure the following has been accomplished:

1. Adequate means must be provided to limit the movement of fryers without depending upon the gas line connector and the quick-disconnect device or its associated piping to limit the appliance movement. If a flexible gas hose is used, a restraining cable must be connected at all times when the fryer is in use. The restraining cable and installation instructions are packed with the flexible hose in the accessories box that was shipped with your unit.



The appliance area must be kept free and clear of combustible material at all times.

2. Frymaster recommends that the minimum distance from the flue outlet to the bottom edge of the hood be 24 in. (600 mm) when the appliance consumes more than 120,000 BTU per hour.
3. Test the fryer electrical system:
 - a. Plug the fryer electrical cord(s) into a grounded electrical receptacle. **NOTE: To ensure the safe and efficient operation of the fryer and hood, the electrical plug for the 100 volt to 120-volt line, which powers the hood, must be fully engaged and locked in its pin and sleeve socket.**
 - b. Place the power switch in the **ON** position.
 - For fryers having controllers, verify that the display indicates the controller is on.
 - If the store is equipped with a hood interlock system, the hood exhaust fan should be on. If not, the store hood interlock system is improperly wired and must be corrected.
 - c. Place the fryer power switch in the **OFF** position. Verify that the display indicates OFF. The hood exhaust system should be off when all controllers display OFF.
4. Refer to the data plate on the inside of the fryer door to determine if the fryer burner is configured for the proper type of gas before connecting the fryer quick-disconnect device or piping from the gas supply line.
5. Verify the minimum and maximum gas supply pressures for the type of gas to be used in accordance with the accompanying tables and the data plate on the inside of the fryer door.

| Non-CE Standard for Gas Pressure | | |
|--------------------------------------|------------------|-----------------|
| Fryer Model | FQG30-T | |
| Gas Type | Nat (Natural) | LP (Propane) |
| Incoming Min Pressure WC/kPa/mbar | 6/1.49/14.93 | 11/2.74/27.37 |
| Incoming Max Pressure WC/kPa/mbar | 14/3.48/34.84 | 14/3.48/34.84 |
| Orifice Size (mm) | 3.18 | 2.10 |
| Number of Orifices | 2 | 2 |
| Burner Manifold Pressure WC/kPa | 3.00/0.73 | 8.25/2.5 |

(1) mbar = 10,2 mm H₂O

| Korea Standard for Gas Pressure | | |
|--------------------------------------|------------------|------------------|
| Fryer Model | FQG30-T | |
| Gas Type | LNG (Natural) | LPG (Propane) |
| Incoming Min Pressure WC/kPa/mbar | 4/1.00/10.00 | 9.2/2.30/23.00 |
| Incoming Max Pressure WC/kPa/mbar | 10/2.50/25.00 | 13.2/3.30/33.00 |
| Orifice Size (mm) | 3.18 | 2.10 |
| Number of Orifices | 2 | 2 |
| Burner Manifold Pressure WC/kPa | 3.00/0.73 | 8.25/2.5 |

(1) mbar = 10,2 mm H₂O

| CE Standard for Gas Pressure | | | | |
|---|-------------------------------|--|-------------------------------|----------------|
| Fryer Model | FQG30-T | | | |
| Gas Type | G20 Natural Gas Lacq | G25 Natural Gas Gro- nique | G30 Butane /Propan e | G31 Propane |
| Incoming Min Pressure (mbar) | 20 | 20 | 28/30 | 37 |
| Incoming Max Pressure (mbar) | 20 | 25 | 50 | 50 |
| Orifice Size (mm) | 3.18 | 3.18 | 1.95 | 1.95 |
| Number of Orifices | 2 | 2 | 2 | 2 |
| Regulator Pressure Full Vat (mbar) | 7 | 10 | 17 | 20.6 |
| Regulator Pressure Dual Vat (mbar) | 8 | 11.2 | 17 | 20.6 |
| Burner Manifold Pressure (mbar) Full Vat | 7 | 10 | 17 | 20.6 |
| Burner Manifold Pressure (mbar) Dual Vat | 8 | 11.2 | 17 | 20.6 |

(1) mbar = 10,2 mm H₂O

- For fryers equipped with a built-in filtration system (FQG30-T models) plug the electrical cord(s) into a power receptacle behind the fryer.

2.4 Connection to Gas Line

DANGER

Before connecting new pipe to this appliance, the pipe must be blown out thoroughly to remove all foreign material. Foreign material in the burner and gas controls will cause improper and dangerous operation.

DANGER

The appliance and its individual shutoff valve must be disconnected from the gas supply piping system during any pressure testing of the system at test pressures in excess of ½ PSI (3.45 kPa, 13.84 inches W.C.) to avoid damage to the fryer's gas tubes and gas valve(s).

⚠ DANGER

The appliance must be isolated from the gas supply piping system by closing its individual manual shutoff valve during any pressure testing of the gas supply piping system at test pressures equal to or less than ½ PSI (3.45 kPa, 13.84 inches W.C.)

⚠ DANGER

“Dry-firing” your unit will cause damage to the frypot and can cause a fire. Always ensure that cooking oil or water is in the frypot before firing the unit.

⚠ DANGER

All connections must be sealed with a joint compound suitable for the gas being used and all connections must be tested with a solution of soapy water before lighting any pilots.

Never use matches, candles, or any other ignition source to check for leaks. If gas odors are detected, shut off the gas supply to the appliance at the main shut-off valve and immediately contact the local gas company or an authorized service agency for service.

The size of the gas line used for installation is very important. If the line is too small, the gas pressure at the burner manifold will be low. This may cause slow recovery and delayed ignition. The incoming gas supply line should be a minimum of 1½" (38 mm) in diameter. Refer to the chart below for the minimum sizes of connection piping.

The FQG30-T™ gas fryer has received the CE mark for the countries and gas categories indicated in the table on the following page. **NOTE:** The nominal heat input (QN) is 21kW except for AT, DE, LU and category 3P/B, which is 23kW.

| Gas Connection Pipe Sizes | | | |
|---|--------------------|--------------------|-------------------------|
| (Minimum incoming pipe size should be 1 1/2" (41 mm)) | | | |
| Gas | Single Unit | 2 - 3 Units | 4 or more units* |
| Natural | 3/4" (22 mm) | 1" (28 mm) | 1 1/4" (36 mm) |
| Propane | 1/2" (15 mm) | 3/4" (22 mm) | 1" (28 mm) |
| Manufactured | 1" (28 mm) | 1 1/4" (36 mm) | 1 1/2" (41 mm) |

* For distances of more than 20 feet (6 m) and/or more than 4 fittings or elbows, increase the connection by one pipe size.

| CE Approved Gas Categories by Country | | | |
|--|-------------------|------------|------------------------|
| COUNTRIES | CATEGORIES | GAS | PRESSURE (MBAR) |
| AUSTRIA (AT) | I12H3B/P | G20 | 20 |
| | | G30, G31 | 50 |
| BELGIUM (BE) | I2E(R)B | G20, G25 | 20, 25 |
| | I3+ | G30, G31 | 28-30, 37 |
| BULGARIA (BG), CROATIA (HR), FINLAND (FI), ROMANIA (RO), SLOVENIA (SI), TURKEY (TR) | I12H3B/P | G20 | 20 |
| | | G30, G31 | 30 |
| ESTONIA (EE), LATVIA (LV) | I2H | G20 | 20 |
| FRANCE (FR) | I12Esi3+ | G20, G25 | 20, 25 |
| | | G30, G31 | 28-30, 37 |
| | I12Esi3P | G20, G25 | 20, 25 |
| | | G31 | 50 |
| GERMANY (DE) | I12ELL3B/P | G20, G25 | 20 |
| | | G30, G31 | 50 |
| | I3P | G31 | 50 |
| HUNGARY (HU) | I12HS3B/P | G25 | 25 |
| | | G30, G31 | 50 |
| CYPRUS (CY), CZECH REPUBLIC (CZ), GREECE (GR), IRELAND (IE), ITALY (IT), PORTUGAL (PT), SLOVAKIA (SK), SPAIN (ES), UNITED KINGDOM (GB) | I12H3+ | G20 | 20 |
| | | G30, G31 | 28-30, 37 |
| LUXEMBOURG (LU) | I12E3B/P | G20, G25 | 20 |
| | | G30, G31 | 50 |
| NETHERLANDS (NL) | I12L3B/P | G25 | 25 |
| | | G30, G31 | 30 |
| ICELAND (IS), MALTA (MT), NORWAY (NO) | I3B/P | G30, G31 | 30 |
| POLAND (PL) | I12E3B/P | G20, G25 | 20 |
| | | G31 | 37 |
| SWITZERLAND (CH) | I12H3+ | G20 | 20 |
| | | G30, G31 | 28-30, 37 |
| | I12H3B/P | G20 | 20 |
| | | G30, G31 | 50 |
| DENMARK (DK), SWEDEN (SE), LITHUANIA (LT) | I12H3B/P | G20 | 20 |
| | | G30, G31 | 30 |
| | I2H | G20 | 20 |

NOTICE- Australia Only

The air pressure switch on the combustion blower should read: Full Vat units-122pa (0.5 inches W.C.) and for Split Vat units-180pa (0.72 inches W.C.).

CE Standard

Required airflow for the combustion air supply is 2m³/h per kW.

1. Connect the quick-disconnect hose to the fryer quick-disconnect fitting under the front of the fryer and to the building gas line.

NOTE: Some fryers are configured for a rigid connection to the gas supply line. These units are connected to the gas supply line at the rear of the unit.

When using thread compound, use very small amounts on male threads only. Use a pipe thread compound that is not affected by the chemical action of LP gases (Loctite™ PST56765 Sealant is one such compound). DO NOT apply compound to the first two threads. Doing so may allow some of the compound to enter the gas stream, resulting in clogging of burner orifices and/or the control valve.

2. Open the gas supply to the fryer and check all piping, fittings, and gas connections for leaks. A soap solution should be used for this purpose.
3. Light the fryer following the procedures that are described in the “Lighting Instructions” found in Chapter 3 of this manual.

DANGER

“Dry-firing” your unit will cause damage to the frypot and can cause a fire. Always ensure that cooking oil or water is in the frypot before firing your unit.

4. The burner manifold pressure should be checked at this time by the local gas company or an authorized service agent. The tables on page 2-5 list the burner manifold gas pressures for the various gas types that can be used with this equipment. Also verify the pressures, on the rating plate, inside the fryer door
5. Check the programmed temperature thermostat setting by pressing the temperature button.

2.5 Converting to Another Gas Type

DANGER

This appliance was configured at the factory for a specific type of gas. Converting from one type of gas to another requires the installation of specific gas-conversion components. Conversion instructions are included with conversion kits.

Switching to a different type of gas without installing the proper conversion components may result in fire or explosion. NEVER ATTACH THIS APPLIANCE TO A GAS SUPPLY FOR WHICH IT IS NOT CONFIGURED!

Conversion of this appliance from one type of gas to another should only be performed by qualified, licensed, and authorized installation or service personnel, as defined in Section 1.6 of this manual.

FQG30-T™ gas fryers manufactured for Non-CE countries use different burners for each type gas. The burners in fryers built for propane gas have a special gray-colored coating on the burner tiles to enable them to withstand the higher caloric value of the propane gas. Burners designed for use in propane units may be used in natural gas applications, but not vice versa.

| Non-CE Gas Conversion Kits | |
|--|--|
| Natural Gas to Propane (LP) Gas | Propane (LP) Gas to Natural Gas |
| Full Vat: PN 826-2965 | Full Vat: PN 826-2967 |
| Dual Vat: PN 826-2966 | Dual Vat: PN 826-2968 |

| Non-CE Gas Conversion Kits for Australia | |
|---|--|
| Natural Gas to Propane (LP) Gas | Propane (LP) Gas to Natural Gas |
| Full Vat: PN 826-2969 | Full Vat: PN 826-2971 |
| Dual Vat: PN 826-2970 | Dual Vat: PN 826-2972 |

Units manufactured for export to CE countries are equipped with “universal” burners that may be used with either Natural (G20, G25) gas or Butane (G30) and Propane (G31) gases.

| CE Gas Conversion Kits for Units with Gas Valve 810-1715 | |
|---|--|
| G20 or G25 (Natural) to G30 or G31 Gas: | G30 or G31 to G20 or G25 (Natural) Gas: |
| PN 826-2975 | PN 826-2976 |

| CE GAS CONVERSION INSTRUCTIONS |
|--|
| <ol style="list-style-type: none">1. Between G20- and G25-type Natural Gas, adjust the gas pressure at the regulator. (Refer to the CE Standard Burner Manifold Gas Pressure Chart.) Do not change the orifice.2. Between a 2nd family (G20 or G25) and a 3rd family gas (G30 Butane or G31 Propane):<ol style="list-style-type: none">a. Change the orifices.b. Adjust the manifold pressure.3. Remove the old rating plate and return to Frymaster. Affix the new rating plate included with the conversion kit in place of the old rating plate stating the gas has been converted.4. If the destination language changes, replace the rating plate. Call your local service agency or KES for a label kit. The language of reference will be on the corner of the label. |

2.6 After Fryers are Positioned at the Frying Station

| |
|---|
| <p style="text-align: center;"> DANGER</p> <p>No structural material on the fryer should be altered or removed to accommodate placement of the fryer under a hood. Questions? Call the Frymaster Dean Service Hotline at 1-800-551-8633.</p> |
|---|

1. Once the fryer has been positioned at the frying station, use a carpenter's level placed across the top of the frypot to verify that the unit is level, both side-to-side and front-to-back.

To level fryers, adjust the casters being careful to ensure the fryer(s) are at the proper height in the frying station.

When the fryer is leveled in its final position, install the restraints provided by the KES to limit its movement so that it does not depend on or transmit stress to the connection. Install the restraints in accordance with the provided instructions. If the restraints are disconnected for service or other reasons, they must be reconnected before the fryer is used.

⚠ DANGER

Hot oil can cause severe burns. Avoid contact. Under all circumstances, oil must be removed from the fryer before attempting to move it to avoid spills, falls, and severe burns. Fryers may tip and cause personal injury if not secured in a stationary position.

⚠ DANGER

Adequate means must be provided to limit the movement of this appliance without depending on the connector and the quick-disconnect device or its associated piping to limit the appliance movement.

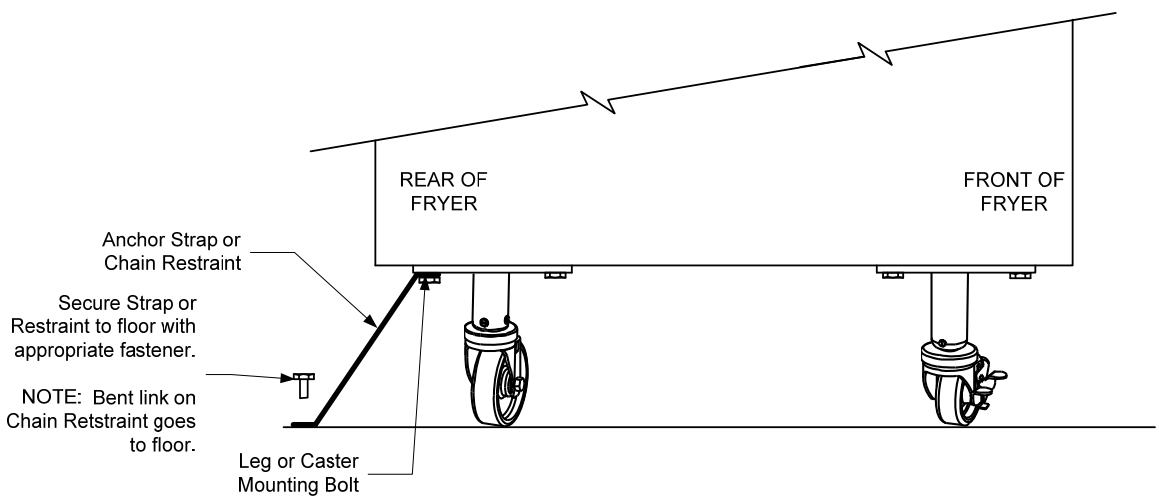

2. **Clean, and fill frypot(s) with cooking oil.** (See *Equipment Setup and Shutdown Procedures* in Chapter 3.)

FILTERQUICK™ FQG30-T TACO BELL GAS FRYER

CHAPTER 3: OPERATING INSTRUCTIONS

FINDING YOUR WAY AROUND THE FQG30-T™ SERIES GAS FRYER

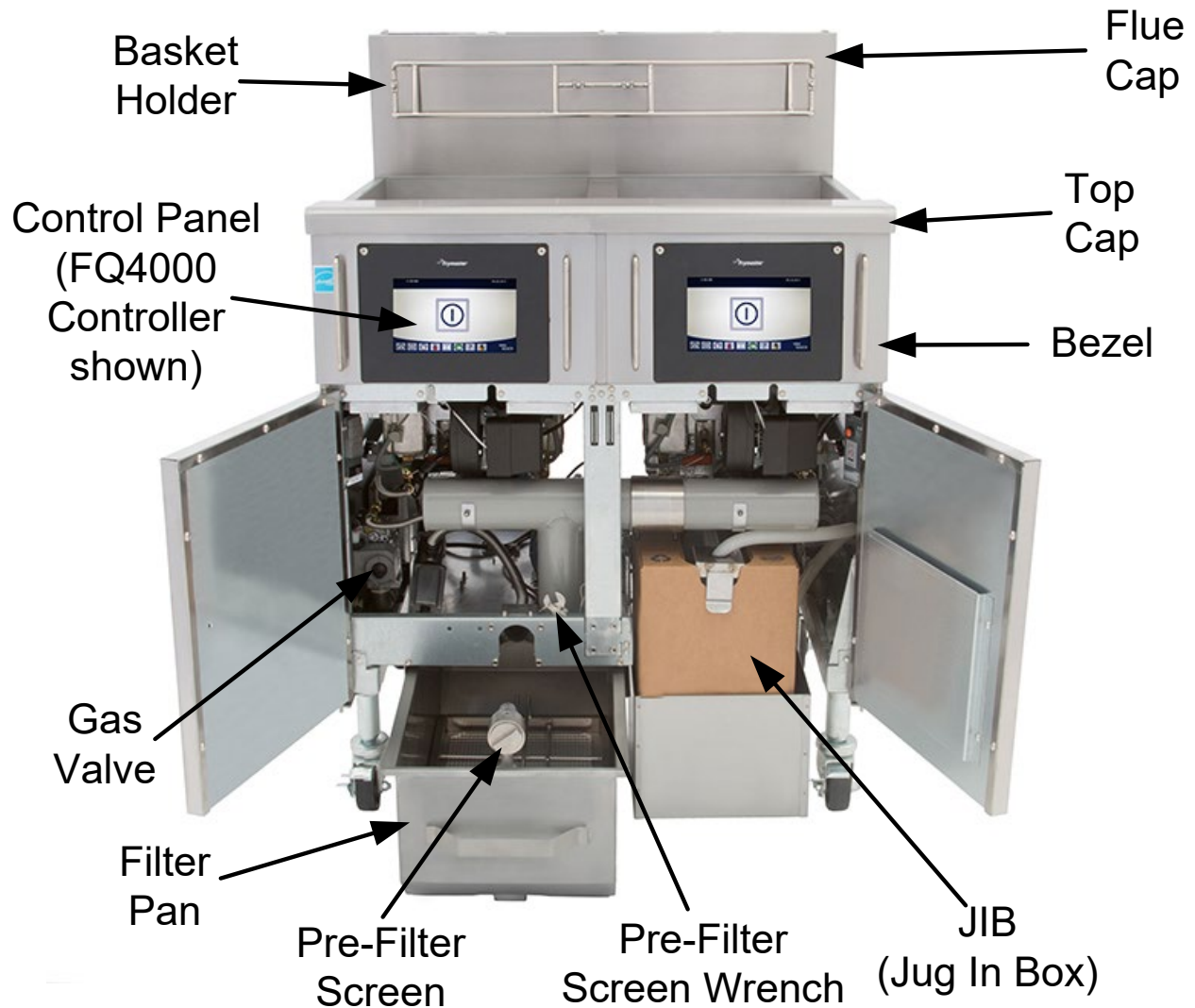

TYPICAL CONFIGURATION (2FQG30-T SHOWN)

NOTE: The appearance of your fryer may differ slightly from that shown depending upon configuration and date of manufacture.

3.1 Equipment Setup and Shutdown Procedures

⚠ WARNING

The on-site supervisor is responsible for ensuring that operators are made aware of the inherent hazards of operating a hot oil filtering system, particularly the aspects of oil filtration, draining and cleaning procedures.

⚠ CAUTION

Before lighting the fryer, make sure the fryer is OFF and the frypot drain valves are closed. Remove the basket support rack(s), if installed, and fill the frypot to the bottom OIL-LEVEL line. If solid shortening is being used, make sure it is packed down into the bottom of the frypot.

3.1.1 Setup

⚠ WARNING

Never operate this appliance with an empty frypot. The frypot must be filled with water or oil before lighting the burners. Failure to do so will damage the frypot and may cause a fire.

⚠ DANGER

Remove all drops of water from the frypot before filling with oil. Failure to do so will cause spattering of hot liquid when the oil is heated to cooking temperature.

⚠ WARNING

The FQG30-T™ is not intended to use solid shortening without a solid shortening kit installed. The use of solid shortening without a solid shortening kit will clog the top off oil lines. The oil capacity of the FQG30-T™ gas fryer is 32 lbs. (3.8 gallons/14.5 liters) at 70°F (21°C) for a full-vat and 18 lbs. (2.2 gallons/8.33 liters) at 70°F (21°C) for each half of a dual-vat.

Prior to filling frypots with oil, plug in the fryer and ensure all the controllers display **OFF** to ensure all drains are closed.

1. Fill the frypot with cooking oil to the **bottom OIL LEVEL line** located on the rear of the frypot. This will allow for oil expansion as heat is applied. Do not fill cold oil any higher than the bottom line; overflow may occur as heat expands the oil. If solid shortening is used, make sure it is packed down into the bottom of the frypot.
2. Ensure that the power cord(s) is/are plugged into the appropriate receptacle(s). Verify that the face of the plug is flush with the outlet plate, with no portion of the prongs visible.
3. Ensure that the oil level is at the **top OIL LEVEL line** when the oil *is at its cooking temperature*.

3.1.2 Lighting the Fryer

1. Ensure the gas valve is in the ON position.

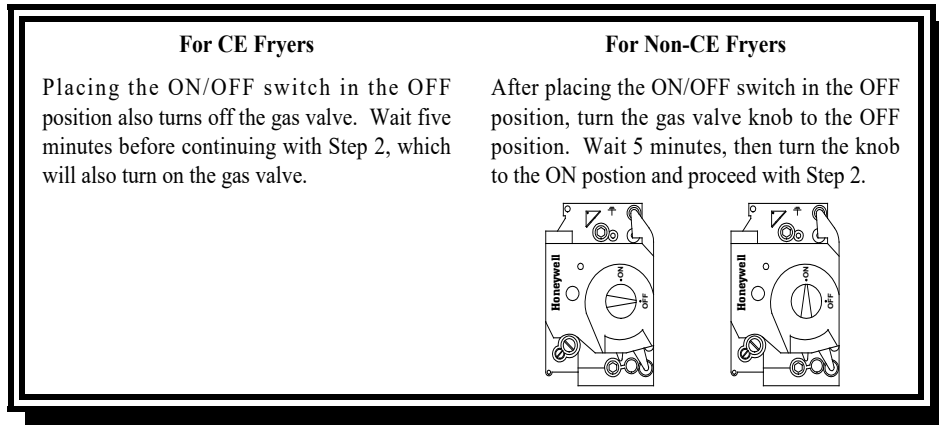

2. Press and hold the controller power switch for 3 seconds to switch the fryer ON.
3. If the burners fail to light, press the power switch to the POWER OFF screen and wait 60 seconds. Repeat step 2.
4. The fryer will automatically enter the melt cycle mode if the frypot temperature is below 180°F (82°C) and will display **MELT CYCLE IN PROGRESS**. (**NOTE:** During the melt cycle, the burners will repeatedly fire for a few seconds, then go out for a longer period.) If using solid shortening, the shortening must be stirred occasionally during the heating process to ensure all the shortening in the drain and vat are liquified. When the frypot temperature reaches 180°F (82°C), the unit will automatically switch to the safe heating mode and **SAFE MODE HEATING IN PROGRESS** and **PREHEAT** are displayed until within 15°F (9°C) of setpoint. If a low oil level is detected, **LOW OIL LEVEL DETECTED. OIL MUST BE ABOVE THE LOWER FILL LINE. FILL FRYPOT WITH OIL BEFORE TURNING ON FRYER** is displayed. Add oil to the frypot and ensure it is between the bottom and top oil fill lines and press the ✓ (check - COMPLETED) button. The burners will remain lit until the frypot temperature reaches the programmed cooking temperature. Once the fryer reaches setpoint, the controller display changes to the product names and the fryer is ready for use.
5. After the burners have been lit for at least 90 seconds, observe the flames through the burner viewing ports located on each side of the combustion air blower.

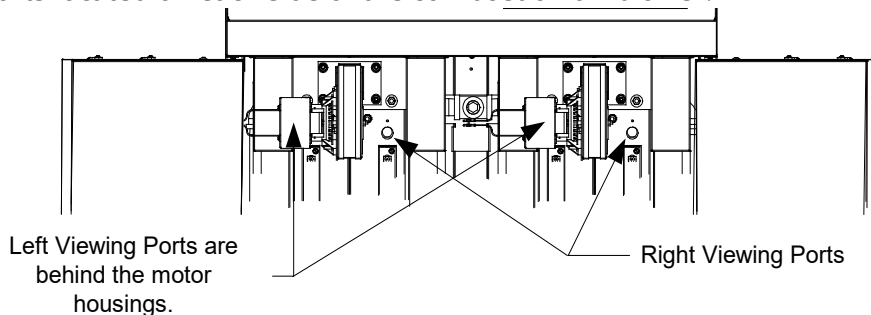

The optimum burn is a bright orange-red glow. If a blue flame is observed, or if there are dark spots on a burner face, adjust the air gas mixture as follows: On the side of the blower housing opposite the motor is a plate with one or two locking nuts. Loosen the nuts enough to allow the plate to be moved, then adjust the position of the plate to open or close the air intake opening until a

bright orange-red glow is obtained. Carefully hold the plate in position and tighten the locking nuts.

3.1.3 Shutdown

For short-term shut down during the workday:

1. Press the power button to the POWER OFF screen and put the frypot covers in place.

When shutting the fryers down at closing time:

1. Press the power button to the POWER OFF screen to turn the fryer off.

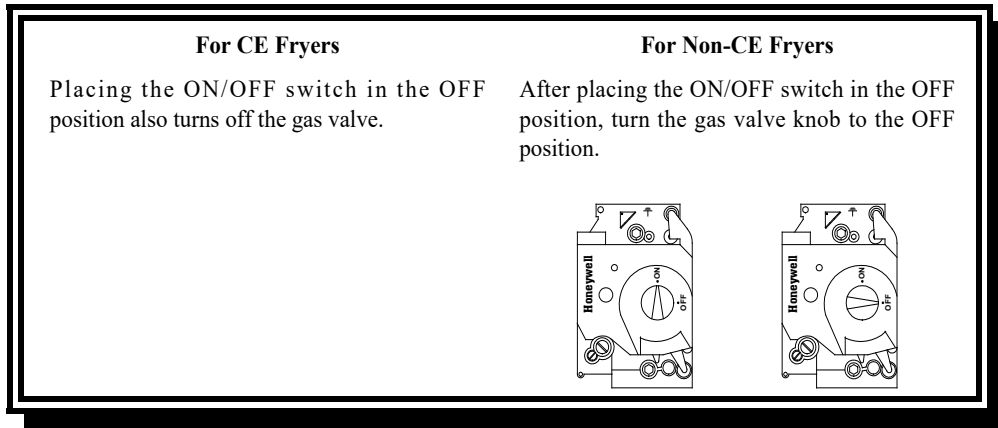

2. Filter the oil and clean the fryers (See Chapters 5 and 6).
3. Clean the filter pan and replace the filter paper. Do not leave solid shortening in the filter pan over night.
4. Place the frypot covers on the frypots.

3.2 Operation

This fryer is equipped with FQ4000 controllers (illustrated below). Refer to the FQ4000 Taco Bell Controller Operation Manual for the controller programming, operating procedures and for operating instructions for the built-in filtration system.



FQ4000 TACO BELL CONTROLLER

3.3 Manual Top-Off Low Oil Volume Automatic Refill

The fryer can be configured for either manual top off or for both manual and automatic depending on the hardware. When a vat is low, press the manual top off (oil drop) button at the bottom of the screen (see Figure 3) to top off the vat. The controller displays PUSH BUTTON TOP OFF? Press the YES (✓) button. START FILLING? is displayed. Press and hold the button to start filling. Release the button when the oil is at the top oil level line. Press the NO (X) button to exit. If the unit has optional auto top off, the frypot oil levels are continually checked and topped off as necessary from a reservoir in the cabinet.

The top off reservoir holds a 35-pound box of oil. In a typical operation this will last approximately two days.

Components of the system are annotated at the right (see Figure 1).

NOTE: The frypots will require manual filling upon startup or after a disposal or cleaning, unless a bulk fresh oil system is used.

3.3.1 Prepare the System for Use

Once the fryer is positioned under the hood install the JIB (Jug In Box) basket shipped in the accessories pack (see Figure 2). If using the bulk oil option see Appendix A.

3.3.2 Install the oil reservoir or jug (JIB)

Remove the original lid from the oil container and foil liner. Replace with the provided cap, which has connected suction hardware. Ensure the feeder tube from the cap reaches to the bottom of the oil container.

Place the oil container inside the cabinet and slide it into place (as shown on the following page). Avoid catching the suction hardware on the cabinet interior as the container is placed in the fryer. The system is now ready for operation.

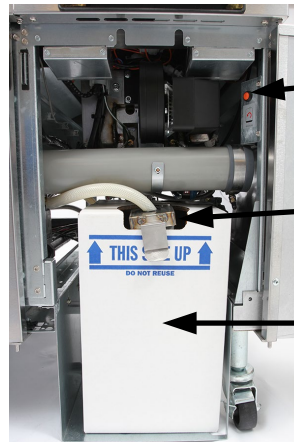

Figure 1

JIB (Jug In Box) Reset Switch: Clears the top off empty display after an oil change. Fills the JIB on bulk oil systems

Special Cap: Has plumbing attached to draw oil from the reservoir to the fryer vats.

Jug In Box (JIB): The JIB is the reservoir for the oil.

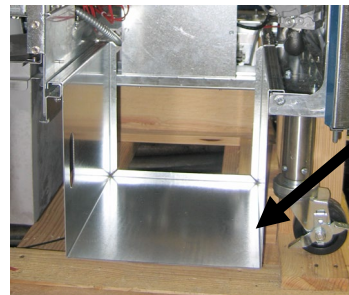

Figure 2

3.3.3 Changing the JIB (Jug In Box) oil reservoir

When the oil reservoir level is low and displays TOP OFF OIL EMPTY – REPLACE JIB, (see Figure 3). Once the reservoir is refilled and/or replaced, press and hold the orange reset button next to the oil reservoir (see Figure 8 on the following page). Press the check button to temporarily clear the screen. The message in the lower corner continues to be displayed until the orange reset button is pressed. If using solid shortening, see Appendix B for instructions.

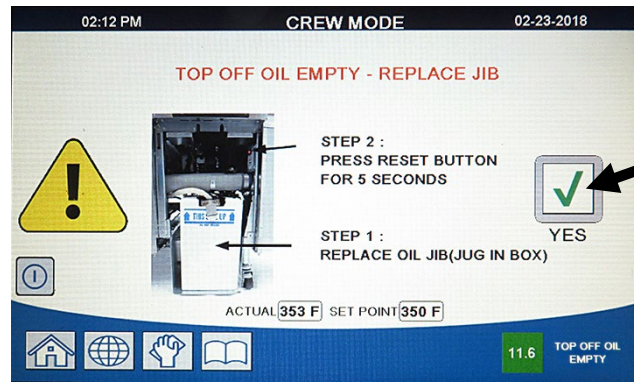

Figure 3

Top Off Oil Empty indicates that the oil reservoir is empty.

1. Open the cabinet and slide the JIB from the cabinet (see Figure 4).



Figure 4

2. Remove the cap and pour any remaining oil in the container into all fry vats equally (see Figure 5).



Figure 5

3. Place new JIB upright and remove the cap and foil seal (see Figure 6).



Figure 6

4. Put the tube in the new full container (see Figure 7).



Figure 7

5. Slide the JIB onto the shelf inside the fryer cabinet (as seen in Figure 4).

6. Press the JIB reset switch to clear the Top Off Oil Empty display on the FQ4000 controller (see Figure 8).

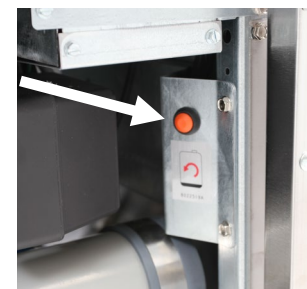

Figure 8

⚠ WARNING
Do not add **HOT** or **USED** oil to a JIB.

3.3.4 Bulk Oil Systems

Instructions for installing and using bulk oil systems are found in Appendix A located at the rear of this manual.

3.4 Filtration

3.4.1 Introduction

The FilterQuick™ filtration system allows the oil in one frypot to be safely and efficiently filtered while the other frypots in a battery remain in operation.

Section 3.4.2 covers preparation of the filter system for use. Operation of the system is covered in the FQ4000 Taco Bell Controller manual.

⚠ WARNING

The on-site supervisor is responsible for ensuring that operators are made aware of the inherent hazards of operating a hot oil filtering system, particularly the aspects of oil filtration, draining and cleaning procedures.

⚠ WARNING

The filter paper MUST be replaced daily or when the sediment level exceeds the height of the hold down ring.

3.4.2 Preparing the FilterQuick™ with FQ4000 Filtration System for Use with Filter Paper

The FilterQuick™ filtration system uses a filter paper configuration which includes a crumb tray, large hold-down ring, and metal filter screen.

1. Pull the filter pan out from the cabinet and remove the crumb tray, hold-down ring, filter paper and filter screen (see Figure 9). Clean all components with a solution of detergent and hot water then dry thoroughly.

The pan cover must not be removed except for cleaning, interior access, or to allow a shortening disposal unit (SDU) built before January 2004 to be positioned under the drain. Disposal instructions are in the FQ4000 controller manual.

2. Inspect the filter pan connection fitting to ensure that both O-rings are in good condition (see Figure 10).

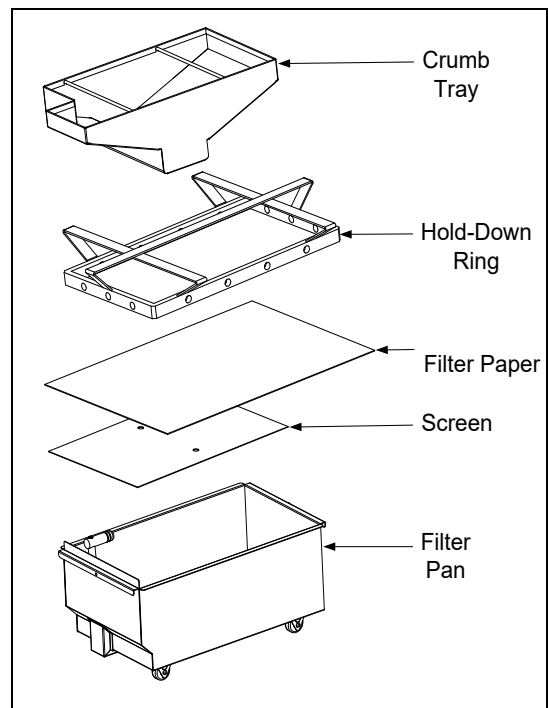

Figure 9

3. Then in reverse order, place the metal filter screen in the center of the bottom of the pan, then lay a sheet of filter paper on top of the screen, overlapping on all sides (see Figure 11).

4. Position the hold-down ring over the filter paper and lower the ring into the pan, allowing the paper to rest on the sides of the filter pan (see Figure 11).

5. Replace the crumb tray in the filter pan, then push the filter pan back into the fryer, positioning it under the drain.

6. Push the filter pan back into the fryer, positioning it under the fryer. Ensure "P" is NOT displayed on the controller. The filtration system is now ready for use.

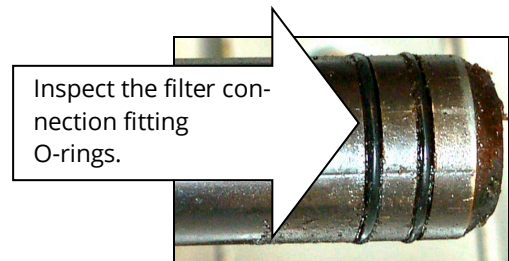

Inspect the filter connection fitting O-rings.

Figure 10

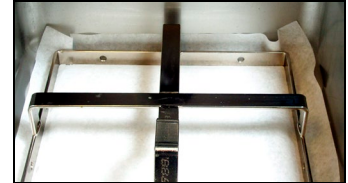

Figure 11

⚠ DANGER

Do not drain more than one frypot at a time into the built-in filtration unit to avoid overflow and spillage of hot oil that may cause severe burns, slipping and falling.

⚠ DANGER

When using a sediment basket, it MUST be removed and emptied prior and during each filtration. Some food particles can spontaneously combust if left soaking in certain shortening material.

⚠ DANGER

The crumb tray in fryers equipped with a filter system must be emptied into a fire-proof container at the end of frying operations each day. Some food particles can spontaneously combust if left soaking in certain shortening material.

⚠ WARNING

Do not bang fry baskets or other utensils on the fryer's joiner strip. The strip is present to seal the joint between the fry vessels. Banging fry baskets on the strip to dislodge shortening will distort the strip, adversely affecting its fit. It is designed for a tight fit and should only be removed for cleaning.

FILTERQUICK™ FQG30-T TACO BELL GAS FRYER

CHAPTER 4: PREVENTATIVE MAINTENANCE

4.1 FRYER PREVENTATIVE MAINTENANCE CHECKS AND SERVICE

 **DANGER**

The crumb tray in fryers equipped with a filter system must be emptied into a fireproof container at the end of frying operations each day. Some food particles can spontaneously combust if left soaking in certain shortening material.

 **DANGER**

When using a sediment basket, it **MUST** be removed and emptied prior and during each filtration. Some food particles can spontaneously combust if left soaking in certain shortening material.

 **DANGER**

Never attempt to clean the fryer during the frying process or when the frypot is filled with hot oil. If water comes in contact with oil heated to frying temperature, it will cause spattering of the oil, which can result in severe burns to nearby personnel.

 **WARNING**

Use a multi-purpose detergent. Read the directions for use and precautionary statements before use. Particular attention must be paid to the concentration of cleaner and the length of time the cleaner remains on the food-contact surfaces.

4.2 DAILY CHECKS AND SERVICE

4.2.1 Inspect Fryer and Accessories for Damage

Look for loose or frayed wires and cords, leaks, foreign material in frypot or inside cabinet, and any other indications that the fryer and accessories are not ready and safe for operation.

4.2.2 Clean Fryer Cabinet Inside and Out - Daily

Clean inside the fryer cabinet with dry, clean cloth. Wipe all accessible metal surfaces and components to remove accumulations of oil and dust.

Clean the outside of the fryer cabinet with a clean, damp cloth soaked with a multi-purpose detergent, removing oil, dust, and lint from the fryer cabinet. Wipe with a clean, damp cloth.

4.2.3 Clean the Built-In Filtration System - Daily

 **WARNING**

Never operate the filter system without oil in the system.

⚠ WARNING

Never use the filter pan to transport old oil to the disposal area.

⚠ WARNING

Never drain water into the filter pan. Water will damage the filter pump.

There are no periodic preventive maintenance checks and services required for your filtration system other than daily cleaning of the filter pan with a solution of hot water and a multi-purpose detergent.

If you notice that the systems is pumping slowly or not at all, verify that the filter pan screen is on the bottom of the filter pan, with the paper on top of the screen. Verify that the two O-ring(s) on the fitting at the right front of the filter pan are present and in good condition. Verify that the pre-filter is clean and tightened with the wrench.

4.2.4 Clean Filter Pan, Detachable Parts and Accessories - Daily

As with the frypot, a deposit of carbonized oil will accumulate on the filter pan and detachable parts and accessories such as baskets, sediment trays, or fishplates.

Wipe the filter pan and all detachable parts and accessories with a clean dry cloth. Use a cloth dampened with a solution of a multi-purpose detergent. To remove accumulated carbonized oil. Rinse and thoroughly dry each part. DO NOT use steel wool or abrasive pads to clean these parts. The scratches that result from such scrubbing make subsequent cleanings more difficult.

4.2.5 Clean around AIF and ATO sensors - Daily

1. Clean the sediment from around the AIF and ATO sensors during clean and filter when the oil is drained from the frypot.
2. Use a screwdriver or other similar object which allows access around the probe (see Figure 1). Use caution to ensure that the probe is not damaged.
3. Return the oil once the clean and filter is complete.

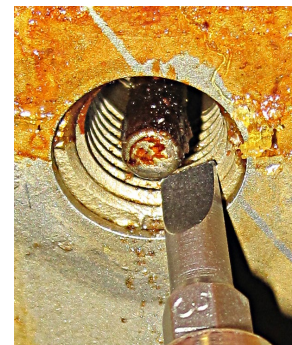

Figure 1

4.2.6 Clean Basket Lift Rods - Daily

On fryers equipped with basket lifts, wipe down the rods with dry, clean cloth to remove accumulations of oil and dust.

4.3 WEEKLY CHECKS AND SERVICE

4.3.1 Clean Behind Fryers

Clean behind fryers. Shut off and disconnect the gas. Use the manual gas shut-off valve to shut off the gas supply. The manual gas shut-off valve is located on the supply line before the quick disconnects. Then disconnect the gas line from the fryer via the quick disconnect.

4.4 MONTHLY CHECKS AND SERVICE

4.4.1 Pre-filter Maintenance - Monthly

The pre-filter requires regular maintenance. Every 30 days, or more frequently if the flow of oil slows, remove the cap and clean the attached screen.

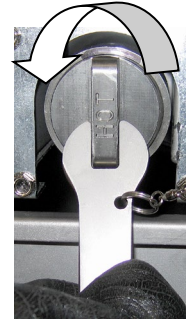

Figure 2

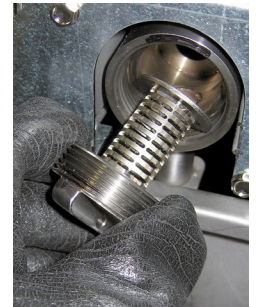

Figure 3

⚠ DANGER
Wear protective gloves when removing the pre-filter. The filter may be hot and cause severe burns.

1. **Wearing protective gloves** use the supplied wrench to re-cap from the pre-filter (**Figure 2**).
2. Use a small brush to clear debris from the attached screen (**Figure 3**).
3. Clean under a water tap and thoroughly dry.
4. Return the cap to the pre-filter housing and tighten with the attached wrench, ensuring the pre-filter is tight. If the cap is not tight, air will leak around the pre-filter and slow the return

move the

⚠ WARNING
DO NOT remove the pre-filter cap when a filter cycle is under way.
DO NOT operate the filter system with the cap removed. Wear protective gloves when handling the cap. The metal and the exposed oil are hot.

4.4.2 Check FQ4000 Controller Set Point Accuracy - Monthly

1. Insert a good-grade thermometer or pyrometer probe into the oil, with the end touching the fryer temperature-sensing probe.
2. When the controller product icons are visible (indicating that the frypot contents are within the cooking range), press the  button once to display the temperature and setpoint of the oil as sensed by the temperature probe.
3. Note the temperature on the thermometer or pyrometer. Actual temperature and pyrometer readings should be within $\pm 5^{\circ}\text{F}$ (3°C) of each other. If not, contact a Factory Authorized Servicer for assistance.

4.5 QUARTERLY CHECKS AND SERVICE

4.5.1 Clean Combustion Air Blower Assembly - Quarterly

1. Disconnect the blower wiring harness and remove the four blower mounting nuts. (See Figure 4)
2. Remove the blower from the fryer cabinet.
3. Remove the blower shield or shield assembly.
4. Remove the three fasteners that secure the blower motor assembly to the blower housing, and separate the two components. (See Figure 5)

Wiring connection

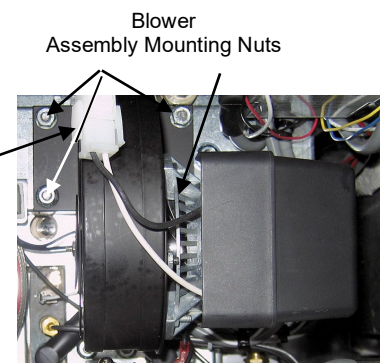

Figure 4

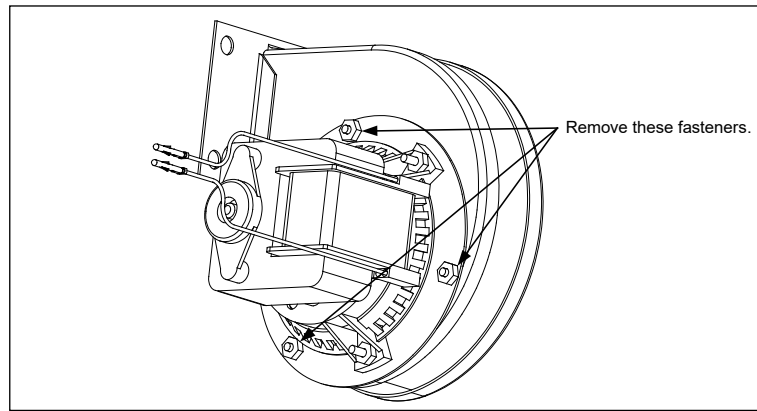

Figure 5

5. Wrap the motor with plastic wrap to prevent water from entering it. Spray degreaser or detergent on the blower wheel and the blower housing. Allow it to soak for five minutes. Rinse the wheel and housing with hot tap water, then dry with a clean cloth. (See Figure 6)
6. Remove the plastic wrap from the blower motor assembly. Reassemble the blower motor assembly and blower housing. Reinstall the blower assembly in the fryer.

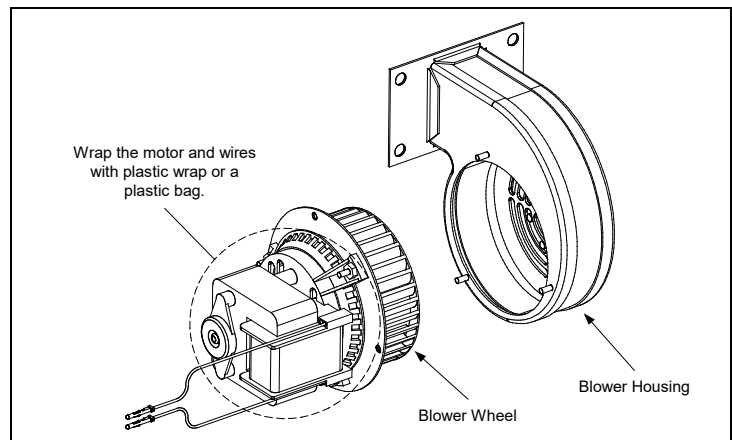

Figure 6

7. Reinstall the blower shield or shield assembly.
8. Light the fryer in accordance with the procedure described in Chapter 3, Section 3.1.2.
9. After the burners have been lit for at least 90 seconds, observe the flames through the burner viewing ports located on each side of the combustion air blower. (See Figure 7)

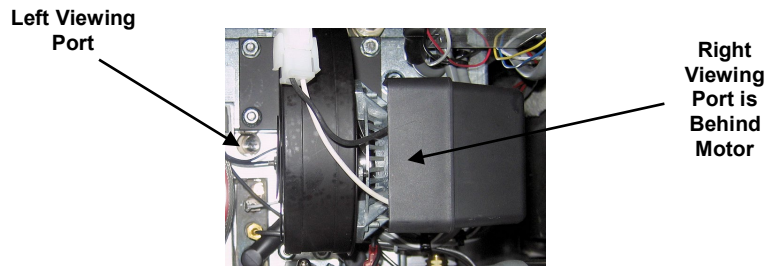

Figure 7

The air/gas mixture is properly adjusted when the burner manifold pressure is in accordance with the applicable table in Chapter 2, Section 2.3 and the burners display a bright orange-red glow. If a blue flame is observed, or if there are dark spots on a burner face, the air/gas mixture requires adjustment.

On the side of the blower housing opposite the motor is a plate with one or two locking nuts (see Figure 8). Loosen the nut(s) enough to allow the plate to be moved. Adjust the position of the plate to open or close the air intake opening until a bright orange-red glow is obtained. Carefully hold the plate in position and tighten the locking nut(s).

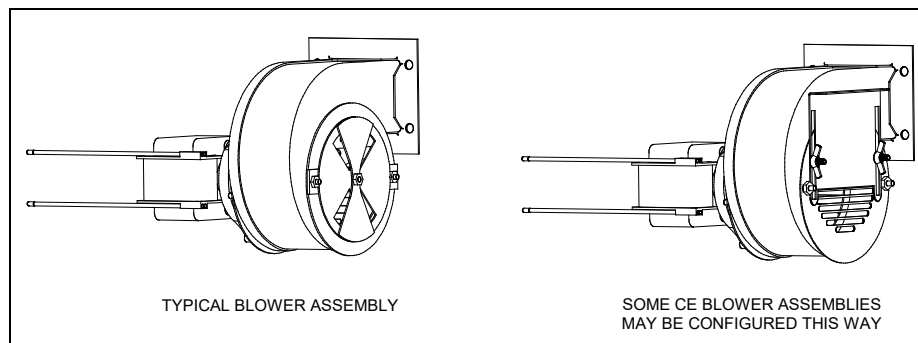

Figure 8

4.5.2 Replace the O-rings - Quarterly

Replace the O-rings on the filter connection (see Figure 10 in section 3.4.2) of oil.

4.6 SEMI-ANNUAL CHECKS AND SERVICE

4.6.1 Clean Gas Valve Vent Tube – Semi-Annual

NOTE: This procedure is not required for fryers configured for export to CE countries.

1. Set the fryer power switch and the gas valve to the OFF position.
2. Carefully unscrew the vent tube from the gas valve. **NOTE:** The vent tube may be straightened for ease in removal.
3. Pass a piece of ordinary binding wire through the tube to remove any obstruction.
4. Remove the wire and blow through the tube to ensure it is clear.
5. Reinstall the tube and bend it so that the opening is pointing downward.

4.7 ANNUAL/PERIODIC SYSTEM INSPECTION

This appliance should be inspected and adjusted periodically by qualified service personnel as part of a regular kitchen maintenance program.

Frymaster recommends that a Factory Authorized Servicer inspect this appliance at least annually as follows:

4.7.1 Fryer - Annual

- Inspect the cabinet inside and out, front and rear for excess oil.
- Verify that debris or accumulations of solidified oil do not obstruct the flue opening.
- Verify that burners and associated components (i.e. gas valves, pilot assemblies, ignitors, etc.) are in good condition and functioning properly. Inspect all gas connections for leaks and verify that all connections are properly tightened.
- Verify that the burner manifold pressure is in accordance with that specified on the appliance's rating plate.
- Verify that the temperature and high-limit probes are properly connected, tightened and functioning properly, and that probe guards are present and properly installed.
- Verify that component box components (i.e. controller, transformers, relays, interface boards, etc.) are in good condition and free from oil and other debris. Inspect the component box wiring and verify that connections are tight and that wiring is in good condition.
- Verify that all safety features (i.e. reset switches, etc.) are present and functioning properly.
- Verify that the frypot is in good condition and free of leaks and that the frypot insulation is in serviceable condition.
- Verify that wiring harnesses and connections are tight and in good condition.

4.7.2 Built-In Filtration System - Annual

- Inspect all oil-return and drain lines for leaks and verify that all connections are tight.
- Inspect the filter pan for leaks and cleanliness. If there is a large accumulation of crumbs in the crumb basket, advise the owner/operator that the crumb basket should be emptied into a fire-proof container and cleaned daily.
- Verify that all O-rings and seals are present and in good condition. Replace O-rings and seals if worn or damaged.
- Check filtration system integrity as follows:
 - Verify that filter pan cover is present and properly installed.
 - With the filter pan empty, place each vat into fill vat from filter pan selection (see section 2.3.7 of the *FQ4000 Controller Operation Manual*), one at a time. Verify proper functioning of each oil return valve by activating the filter pump using the fill vat from drain pan selection. Verify that the pump activates and that bubbles appear in the cooking oil of the associated frypot.
 - Verify that the filter pan is properly prepared for filtering, then drain a frypot of oil heated to 350°F (177°C) into the filter pan by using the drain to pan selection (see section 2.3.6 of the *FQ4000 Controller Operation Manual*). Now using the fill vat from pan drain pan selection (see section 2.3.7 of the *FQ4000 Controller Operation Manual*), allow all oil to return to the frypot (indicated by bubbles in the cooking oil). Press the check button when all oil is returned. The frypot should have refilled in approximately 2 minutes and 30 seconds.

FILTERQUICK™ FQG30-T TACO BELL GAS FRYER

CHAPTER 5: OPERATOR TROUBLESHOOTING

5.1 Introduction

This chapter provides an easy reference guide to some of the common problems that may occur during the operation of your equipment. The troubleshooting guides that follow are intended to help you correct, or at least accurately diagnose, problems with your equipment. Although the chapter covers the most common problems reported, you may encounter problems that are not covered. In such instances, the Frymaster Technical Services staff will make every effort to help you identify and resolve the problem.

When troubleshooting a problem, always use a process of elimination starting with the simplest solution and working through to the most complex. Most importantly, always try to establish a clear idea of why a problem has occurred. Part of your corrective action involves taking steps to ensure that it doesn't happen again. If a controller malfunctions because of a poor connection, check all other connections. If a fuse continues to blow, find out why. Always keep in mind that failure of a small component may often be indicative of potential failure or incorrect functioning of a more important component or system.

If you are in doubt as to the proper action to take, do not hesitate to call the Frymaster Technical Service Department or your local Frymaster Factory Authorized Servicer for assistance.

Before calling a servicer or the Frymaster HOTLINE (1-800-551-8633):

- **Verify that electrical cords are plugged in and that circuit breakers are on.**
- **Verify that gas line quick-disconnects are properly connected.**
- **Verify that any gas line cutoff valves are open.**
- **Verify that frypot drain valves are fully closed.**
- **Have your fryer's model and serial numbers ready to give the technician assisting you.**

 **DANGER**

Hot oil will cause severe burns. Never attempt to move this appliance when filled with hot oil or to transfer hot oil from one container to another.

 **DANGER**

This equipment should be unplugged when servicing, except when electrical circuit tests are required. Use extreme care when performing such tests.

This appliance may have more than one electrical power supply connection point. Disconnect all power cords before servicing.

Inspection, testing, and repair of electrical components should be performed by an authorized service agent only.

5.2 Troubleshooting Fryers

| PROBLEM | PROBABLE CAUSES | CORRECTIVE ACTION |
|---|---|---|
| No display on the controller. | A. No power to fryer. B. Failed controller or another component | A. Verify that the fryer is plugged in and that the circuit breaker is not tripped. B. Call your FAS for assistance. |
| Controller locks up. | Controller error. | Remove and restore power to the controller. If problem persists, call your FAS for assistance. |
| Fryer does not heat. | A. Drain valve not fully closed. B. Gas valve is not turned on. C. Manual gas shut off valve closed. D. Improperly connected quick-disconnect fitting on gas line. E. Obstructed or failed combustion air blower. | A. Check error log. Ensure that E33 is not displayed. B. Turn the gas valve knob to the ON position. C. Verify that any in-line manual shut off and gas main valve is open. D. Verify that the quick-disconnect fitting on the flexible gas line is firmly connected to the fryer. E. Verify that combustion air blower is running. If not, call FAS for service. If combustion air blower is functional, clean and adjust per instructions in Chapter 6 of this manual. |
| Fryer is operating normally, but recovery is slow when cooking. | Dirty or obstructed combustion air blower. | Clean and adjust per instructions in Chapter 6 of this manual. |
| Fryer is operating normally, but produces a popping sound when burners ignite. | A. Dirty or obstructed combustion air blower. B. Dirty or obstructed gas valve vent tube (non-CE fryers only). C. Malfunctioning combustion air blower. | A. Clean and adjust per instructions in Chapter 6 of this manual. B. Clean per instructions in Chapter 6 of this manual. C. Call your FAS. |
| FQ4000 displays E19 or E28 HEATING FAILURE. | Gas valve off, failed controller, failed transformer, contactor or open high-limit thermostat. | It is normal for this message to appear during startup if the lines have air in them. Check that the gas valve is on. If the gas is on and it continues shut the fryer down and call your FAS for assistance. |
| FQ4000 displays MISCONFIGURED ENERGY TYPE | Energy type in fryer setup is incorrect. | Ensure that the fryer is configured properly for the correct energy type. |
| FQ4000 displays VAT ID CONNECTOR NOT CONNECTED | Controller locator missing or disconnected. | Ensure the 6-pin locator is connected to rear of controller and it properly grounded in control box. |
| FQ4000 display shows HOT-HI-1. | Frypot temperature is more than 410°F (210°C) or, in CE countries, 395°F (202°C). | Shut the fryer down immediately and call your FAS for assistance. |

| PROBLEM | PROBABLE CAUSES | CORRECTIVE ACTION |
|--|---|---|
| FQ4000 displays RECOVERY FAULT and alarm sounds. | Recovery time exceeded maximum time limit. | Clear error and silence the alarm by pressing the check √ button. Maximum recovery time for gas is 3:15. If the error continues call your FAS for assistance. |
| FQ4000 display is in wrong temperature scale (Fahrenheit or Celsius). | Incorrect display option programmed. | Toggle between F° to C° by entering Manager settings, temperature and toggling the temperature scale. Turn the controller on to check temperature. If the desired scale is not displayed, repeat. |
| FQ4000 displays HELP HI-2 or HIGH LIMIT FAILURE DISCONNECT POWER. | Failed high limit | Shut the fryer down immediately and call your FAS for assistance. |
| FQ4000 displays TEMPERATURE PROBE FAILURE. | Problem with the temperature measuring circuitry including the probe or damaged controller wiring harness or connector. | Shut the fryer down and call your FAS for assistance. |
| FQ4000 displays SERVICE REQUIRED followed by an error message. | An error has occurred which requires a service technician. | Press X to continue cooking and call your FAS for assistance. In some cases, cooking may not be allowed. |
| FQ4000 displays NO MENU GROUP AVAILABLE FOR SELECTION | All menu groups have been deleted. NOTE: ALL RECIPES is not a group that can be used to cook recipes. | Create a new MENU group. Once a new menu is created, add recipes to the group (see section 1.10 in the FQ4000 controller manual). |

5.3 Troubleshooting Filtration

| PROBLEM | PROBABLE CAUSES | CORRECTIVE ACTION |
|---|--|---|
| FQ4000 displays CHANGE FILTER PAPER? | Filter error has occurred, filter paper clogged, 25-hour filter paper change prompt has occurred or change filter paper was ignored on a prior prompt. | Change the filter paper and ensure the filter pan has been removed from the fryer for a minimum of 30 seconds. Do NOT ignore CHANGE FILTER PAPER prompts. |
| SAFE MODE - E81 SAFE MODE FAILURE TECHNICAL SUPPORT REQUIRED 1-800-421-4101 ENTER PASSCODE | The oil level is low in the vat. | Check the filter pan to ensure all the oil returned to the vat. Turn fryer off. Ensure the oil level is at the top oil level line or between the two lines. Turn fryer back on. Enter code 4357 if prompted. Call 1-800-421-4101 if issue continues. |

| PROBLEM | PROBABLE CAUSES | CORRECTIVE ACTION |
|--|---|--|
| Drain or return stays open. | A. Valve Interface Board has failed. B. Actuator has failed. | Call your FAS for assistance. |
| FQ4000 displays IS VAT FULL? YES NO after a filtration. | A. Normal operation during most at the beginning or end of most filtration functions. B. If the display appears many times during a filter it could be an indication of slow oil return. | A. Ensure the vat is full of oil and press the ✓ button. B. See section 5.3 troubleshooting – Filter Pump runs, but oil return is very slow. |
| FQ4000 displays IS DRAIN CLEAR? | Drain is clogged and oil failed to drain. | Clear drain with Fryers Friend and press ✓ (check - YES) button. Filtration will resume. |
| FQ4000 displays DO NOT TURN ON FRYER UNLESS FRYPOT IS FULL OF OIL. DO YOU WANT TO TURN FRYER ON? YES NO during or after a filtration. | A. Displayed when the oil does not return to the frypot within a prescribed amount of time. This could be due to a clogged or dirty filter. B. Clogged pre-screen filter. | A. Clean or change the filter and ensure the frypot is full of oil above the lower oil fill line and press the ✓ (check - YES) button to turn the fryer on. B. Clean the pre-screen filter. |
| FQ4000 displays LOW OIL LEVEL DETECTED. OIL MUST BE ABOVE THE LOWER FILL LINE. FILL FRYPOT WITH OIL BEFORE TURNING ON FRYER. | Displayed when the fryer detects a low oil condition. | Ensure the frypot is full of oil and press the ✓ (check - COMPLETED) button. |
| FQ4000 displays CHANGE FILTER PAPER/PAD? | Filter error has occurred, filter paper/pad clogged, 25-hour filter paper/pad change prompt has occurred or change filter paper/pad was ignored on a prior prompt. | Change the filter paper/pad and ensure the filter pan has been removed from the fryer for a minimum of 30 seconds. Do NOT ignore CHANGE FILTER PAPER/PAD prompts. |
| FQ4000 display shows FILTER BUSY. | A. Another filtration cycle or filter pad change is still in process. B. Filter interface board has not cleared checking system. | A. Wait until the previous filtration cycle ends to start another filtration cycle. Change filter pad if prompted. B. Wait 15 minutes and try again. |

| PROBLEM | PROBABLE CAUSES | CORRECTIVE ACTION |
|--|---|--|
| Fryer filters after each cook cycle. | Filter after setting incorrect. | Change or overwrite the filter after setting by re-entering the filter after value in Manager Settings, Filter Attributes in section 1.8 in the FQ4000 controller manual. |
| FQ4000 displays INSERT PAN. | <ul style="list-style-type: none"> A. Filter pan is not fully set into fryer. B. Missing filter pan magnet. C. Defective filter pan switch. | <ul style="list-style-type: none"> A. Pull filter pan out and fully reinsert into fryer. Ensure controller does not display P. B. Ensure the filter pan magnet is in place and replace if missing. C. If the filter pan magnet is fully against the switch and controller continues to display INSERT PAN, switch is possibly defective. |
| Filtration won't start. | <ul style="list-style-type: none"> A. Oil level too low. B. Oil temperature is too low. C. Filter Pan out. D. Filtration in recipe settings is set to OFF. E. Filter relay has failed. | <ul style="list-style-type: none"> A. Ensure oil level is at the top oil fill line (at the top oil level sensor). B. Ensure the oil temperature is at setpoint. C. Ensure controller does not display P. Ensure the filter pan is fully seated into fryer. Power cycle the fryer. D. Set filtration in recipes to ON. E. Call your FAS for assistance. |
| Filter pump won't start or pump stops during filtering. | <ul style="list-style-type: none"> A. Power cord is not plugged in or circuit breaker is tripped. B. Pump motor has overheated causing the thermal overload switch to trip. C. Blockage in filter pump. | <ul style="list-style-type: none"> A. Verify that the power cord is fully plugged in and the circuit breaker is not tripped. B. If the motor is too hot to touch for more than a few seconds, the thermal overload switch has probably tripped. Allow the motor to cool at least 45 minutes then press the Pump Reset Switch (see page 5-5). C. Call your FAS for assistance. |

| PROBLEM | PROBABLE CAUSES | CORRECTIVE ACTION |
|---|---|---|
| Filter Pump runs, but oil return is very slow. | A. Clogged filter paper. B. Improperly installed or prepared filter pan components. C. Pre-filter screen may be clogged or not fully tightened. | A. Ensure the filter is not clogged. If so replace the filter. B. Remove the oil from the filter pan and replace the filter paper, ensuring that the filter screen is in place under the paper. Verify that O-rings are present and in good condition on filter pan connection fitting. C. Clean pre-filter (see section 4.5.4) and ensure it is tightened with the attached wrench. |

5.3.1 Clogged Drain Error

The clogged drain error occurs during auto filtration when the oil level sensor detects that oil has not completely drained from the frypot. This may be due to a clogged drain or an oil sensor failure. Follow the instructions on the controller display to clear the error.

When this occurs the controller displays **CLEAR DRAIN** for 15 seconds changing to **IS DRAIN CLEAR?**

1. Clear debris from the drain using the fryer's friend and press the √ button to continue.
2. The controller displays **DRAINING**. Once the oil level sensor detects the oil has drained, normal auto filtration operation resumes.

5.3.2 Filter Busy

When FILTER BUSY is displayed the filter interface board is waiting on another vat to be filtered or waiting on another function to finish. Wait 15 minutes to see if problem is corrected. If not, call your local FAS.

5.4 Troubleshooting Auto Top Off Issues

| PROBLEM | PROBABLE CAUSES | CORRECTIVE ACTION |
|---------------------------------|--|---|
| Frypots top off cold. | Incorrect setpoint. | Ensure setpoint is correct. |
| One vat doesn't top off. | A. Filter error exists. B. Service required error exists C. Solenoid, pump, pin issue, RTD or ATO issue. | A. Clear filter error properly. If problem persists call your FAS for assistance. B. Call your FAS for assistance. C. Call your FAS for assistance. |

| PROBLEM | PROBABLE CAUSES | CORRECTIVE ACTION |
|-------------------------------|--|--|
| Frypots won't top off. | <ul style="list-style-type: none"> A. Fryer temperature too low. B. Oil is too cold. C. Top oil empty displayed D. Service required error exists E. Melting unit switch is off (only on solid shortening units) F. Blown fuse. | <ul style="list-style-type: none"> A. Fryer temperature must be at setpoint. B. Ensure that the oil in the top off reservoir is above 70°F (21°C). C. Ensure the top off reservoir is not out of oil. Replace top off reservoir or fill from bulk and reset top off system. If problem persists call your FAS for assistance. D. Call your FAS for assistance. E. Ensure the switch on the melting unit is in the ON position. F. Check the fuse on the left of the ATO box. If using a solid shortening melting unit, check the fuse below the melting unit switch. |

5.5 Troubleshooting Bulk Oil System Problems

| PROBLEM | PROBABLE CAUSES | CORRECTIVE ACTION |
|---|--|--|
| Frypot won't fill. | <ul style="list-style-type: none"> A. Incorrect setup procedure. B. Dispose valve not completely closed. C. Bulk oil tank is empty. D. RTI pump issue. | <ul style="list-style-type: none"> A. Power cycle fryer by disconnecting and reconnecting the bulk oil control connector on rear of fryer. B. Ensure the dispose valve handle is pushed fully closed. C. Call your bulk oil provider. D. Call you FAS for assistance. |
| Top off reservoir won't fill. | <ul style="list-style-type: none"> A. Incorrect setup procedure. B. Another function is in process. C. Dispose valve not completely closed. D. Bulk oil tank is empty. E. Solenoid, pump or switch issue. | <ul style="list-style-type: none"> A. Power cycle fryer by disconnecting and reconnecting 5-pin bulk oil control power cord on rear of fryer. B. If a filtration or any other filter menu function is in process or FILTER NOW? YES/NO, CONFIRM YES/NO, or SKIM VAT are displayed, wait until the process is complete and try again. C. Ensure the dispose valve handle is pushed fully closed. D. Call your bulk oil provider. E. Call you FAS for assistance. |
| Top off reservoir or vat filling slow. | Pump or line issues beyond the scope of operator troubleshooting. | Contact your bulk oil provider. |

5.6 Error Log Codes

See section 1.13.2.1 in the FQ4000 Controller manual for instructions to access the Error Log.

| Code | ERROR MESSAGE | EXPLANATION |
|------|--|--|
| E13 | TEMPERATURE PROBE FAILURE | TEMP Probe reading out of range. Call service. |
| E16 | HIGH LIMIT 1 EXCEEDED | High limit temperature is past more than 410°F (210°C), or in CE countries, 395°F (202°C) |
| E17 | HIGH LIMIT 2 EXCEEDED | High limit switch has opened. |
| E18 | HIGH LIMIT PROBLEM DISCONNECT POWER | Vat temperature exceeds 460°F (238°C) and the high limit has failed to open. Immediately disconnect power to the fryer and call service. |
| E19 | HEATING FAILURE – XXX F or XXX C | Heating Control latch circuit failed. Heat Contactor failed to latch. |
| E25 | HEATING FAILURE - BLOWER | The air pressure switch(s) failed to close. |
| E27 | HEATING FAILURE - PRESSURE SWITCH - CALL SERVICE | The air pressure switch has failed closed. |
| E28 | HEATING FAILURE – XXX F or XXX C | The fryer has failed to ignite and has locked out the ignition module. |
| E29 | TOP OFF PROBE FAILURE - CALL SERVICE | ATO RTD reading out of range. Call service |
| E32 | DRAIN VALVE NOT OPEN - FILTRATION AND TOP OFF DISABLED - CALL SERVICE | Drain valve was trying to open and confirmation is missing |
| E33 | DRAIN VALVE NOT CLOSED - FILTRATION AND TOP OFF DISABLED - CALL SERVICE | Drain valve was trying to close and confirmation is missing |
| E34 | RETURN VALVE NOT OPEN - FILTRATION AND TOP OFF DISABLED - CALL SERVICE | Return valve was trying to open and confirmation is missing |
| E35 | RETURN VALVE NOT CLOSED - FILTRATION AND TOP OFF DISABLED - CALL SERVICE | Return valve was trying to close and confirmation is missing |
| E36 | VALVE INTERFACE BOARD FAILURE - FILTRATION AND TOP OFF DISABLED - CALL SERVICE | Valve Interface Board connections lost or board failure. Call service. |
| E37 | AUTOMATIC INTERMITTENT FILTRATION PROBE FAILURE - FILTRATION DISABLED - CALL SERVICE | AIF RTD reading out of range. Call service. |
| E39 | CHANGE FILTER PAPER | 25-hour timer has expired or dirty filter logic has activated. Change the filter paper. |
| E41 | OIL IN PAN ERROR | The system detects that oil may be present in the filter pan. |
| E42 | CLOGGED DRAIN (Gas) | Vat did not empty during filtration. Ensure the drain is not clogged and follow prompts. |
| E43 | OIL SENSOR FAILURE - CALL SERVICE | Oil level sensor may have failed. Call service. |
| E44 | RECOVERY FAULT | Recovery time exceeded maximum time limit. |
| E45 | RECOVERY FAULT – CALL SERVICE | Recovery time exceeded maximum time limit for two or more cycles. Call service. |
| E46 | SYSTEM INTERFACE BOARD 1 MISSING - CALL SERVICE | SIB board 1 connection lost or board failure. Call service. |

| Code | ERROR MESSAGE | EXPLANATION |
|-------------|---|--|
| E51 | DUPLICATE BOARD ID - CALL SERVICE | Two or more controllers have the same location ID. Call service. |
| E52 | USER INTERFACE CONTROLLER ERROR - CALL SERVICE | The controller has an unknown error. Call service. |
| E53 | CAN BUS ERROR - CALL SERVICE | Communications are lost between boards. Call service. |
| E54 | USB ERROR | USB connection lost during an update. |
| E55 | SYSTEM INTERFACE BOARD 2 MISSING - CALL SERVICE | SIB board 2 connection lost or board failure. Call service. |
| E61 | MISCONFIGURED ENERGY TYPE | The fryer is configured for the incorrect energy type. Call service. |
| E62 | VAT NOT HEATING – CHECK ENERGY SOURCE – XXXF OR XXXC | The vat is not heating properly. |
| E63 | RATE OF RISE | Rate of rise error occurred during a recovery test. Ensure the oil level is at the bottom oil level when cold and at the top oil level line when at setpoint. On electric fryers ensure the probe is not touching the elements. |
| E64 | FILTRATION INTERFACE BOARD FAILURE - FILTRATION AND TOP OFF DISABLED - CALL SERVICE | Filtration Interface Board connections lost or board failure. Call service. |
| E65 | CLEAN OIB SENSOR – XXX F OR XXX C - CALL SERVICE | Gas -The oil is back sensor does not detect oil. Clean optional oil sensor. |
| E66 | DRAIN VALVE OPEN – XXXF OR XXXC | Drain valve is opened during cooking. |
| E67 | SYSTEM INTERFACE BOARD NOT CONFIGURED - CALL SERVICE | Controller is turned on when the SIB board is not configured. Call service. |
| E68 | OIB FUSE TRIPPED – CALL SERVICE | The VIB board OIB fuse has tripped and didn't reset. Call service. |
| E69 | RECIPES NOT AVAILABLE – CALL SERVICE | The controller has not been programmed with product recipes. Replace controller with factory programmed controller. |
| E70 | OQS TEMP HIGH | Oil temperature is too high for a valid OQS reading. Filter at a temperature between 300°F (149°C) and 375°F (191°C). |
| E71 | OQS TEMP LOW | Oil temperature is too low for a valid OQS reading. Filter at a temperature between 300°F (149°C) and 375°F (191°C). |
| E72 | TPM RANGE LOW | The TPM is too low for a valid OQS reading. This may also be seen with fresh new oil. The incorrect oil type may be selected in the setup menu. The sensor may not be calibrated for the oil type. See oil type chart in instruction document 8197316. If issue continues contact a FAS. |

| Code | ERROR MESSAGE | EXPLANATION |
|------|-------------------------|--|
| E73 | TPM RANGE HIGH | The TPM reading is too high for a valid OQS reading. Dispose the oil. |
| E74 | OQS ERROR | The OQS has an internal error. If issue continues contact a FAS. |
| E75 | OQS AIR ERROR | The OQS is detecting air in the oil. Check the O-rings and check/tighten prescreen filter to ensure no air is entering the OQS sensor. If issue continues contact a FAS. |
| E76 | OQS ERROR | The OQS sensor has a communication error. Check connections to the OQS sensor. Power cycle the entire fryer battery. If issue continues contact a FAS. |
| E81 | SAFE MODE FAILURE ERROR | The system has detected the fryer is not heating properly due to low oil conditions. Turn the fryer off. Ensure the fryer has oil to the bottom fill line or higher. If not, add oil to the bottom fill line. Turn fryer back on. If prompted, enter code 4357. If issue continues contact a FAS. |

FILTERQUICK™ FQG30-T TACO BELL GAS FRYER

APPENDIX A: BULK OIL CONNECTION AND SETUP INSTRUCTIONS

NOTE: The instructions in this manual for using a bulk oil system for filling and discarding oil are for a bulk oil system. These instructions may not be applicable to some bulk oil systems.

A.1.1 Bulk Oil Systems

Bulk oil systems have large oil storage tanks, typically located in the rear of the restaurant, that are connected to a rear manifold on the fryer. Waste oil is pumped from the fryer, via the fitting located on the left of the manifold on the rear of the fryer, to the disposal tanks and fresh oil is pumped from the tanks, through the fitting located on the right of the manifold, to the fryer (see Figure 1). The 9-pin wire harness allows connection to various bulk oil systems. The wiring diagram is located on the back page.

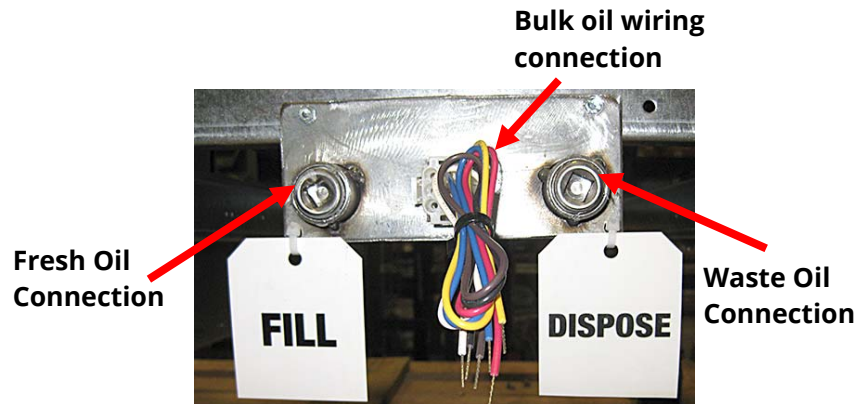

Figure 1

Set the fryer to bulk through the Settings/Service mode on the far-left controller. All vats need to be idle to set these settings.

1. With the controller soft powered off press the HOME button.
2. Press the Settings button.
3. Press the Service button.
4. Enter 3000
5. Press the checkmark button.
6. Press the down arrow button.
7. Press OIL SYSTEM TYPE.
8. Press the BULK button for bulk fresh oil; if no bulk fresh oil is used, leave setting at JIB. The type selected is highlighted.
9. The controller displays SETUP COMPLETE RESTART THE SYSTEM.
10. Press the checkmark button.
11. Press WASTE OIL.
12. Press the bulk button. The type selected is highlighted.
13. The controller displays SETUP COMPLETE RESTART THE SYSTEM.
14. Press the checkmark button.
15. Press the home button to exit.

It is imperative that the fryer system be completely power cycled for at least 60 seconds after changing oil system type or waste oil type.

The FilterQuick™ FQ30-T fryers, equipped for use with bulk oil systems, have an onboard fresh oil jug supplied by the fresh oil bulk provider. Remove the cap and insert the standard fitting into the jug with the metal cap resting on the lip of the jug. The oil is pumped in and out of the jug through the same fitting (see Figure 2).



Figure 2

 **WARNING**
Do not add HOT or USED oil to a top off reservoir.

The momentary switch used to reset the top off reservoir low indicator is also used to fill the jug in a bulk fresh oil system. After pressing the button to reset the top off system, pressing and holding the momentary switch, located above the top off reservoir, allows the operator to fill the jug from the bulk oil storage tank (see Figure 3).

To fill the jug, press and hold the top off reset button until the jug is full, then release.*



Figure 3

NOTE: Do NOT overfill the jug.

For instructions on filling the vat from bulk, see Section 2.3.8 in the FQ4000 Controller manual. To dispose to bulk see section 2.3.13 in the FQ4000 Controller manual.

*** NOTE:** It takes approximately twelve seconds from the time the top off reset button is pressed until the bulk fresh oil pump starts. It may take up to 20 seconds before the level in the top off reservoir begins to rise. Typically, it takes approximately three minutes to fill the reservoir. It takes approximately one minute to fill a split vat and two minutes to fill a full vat.

A.1.2 Bulk Oil Wiring

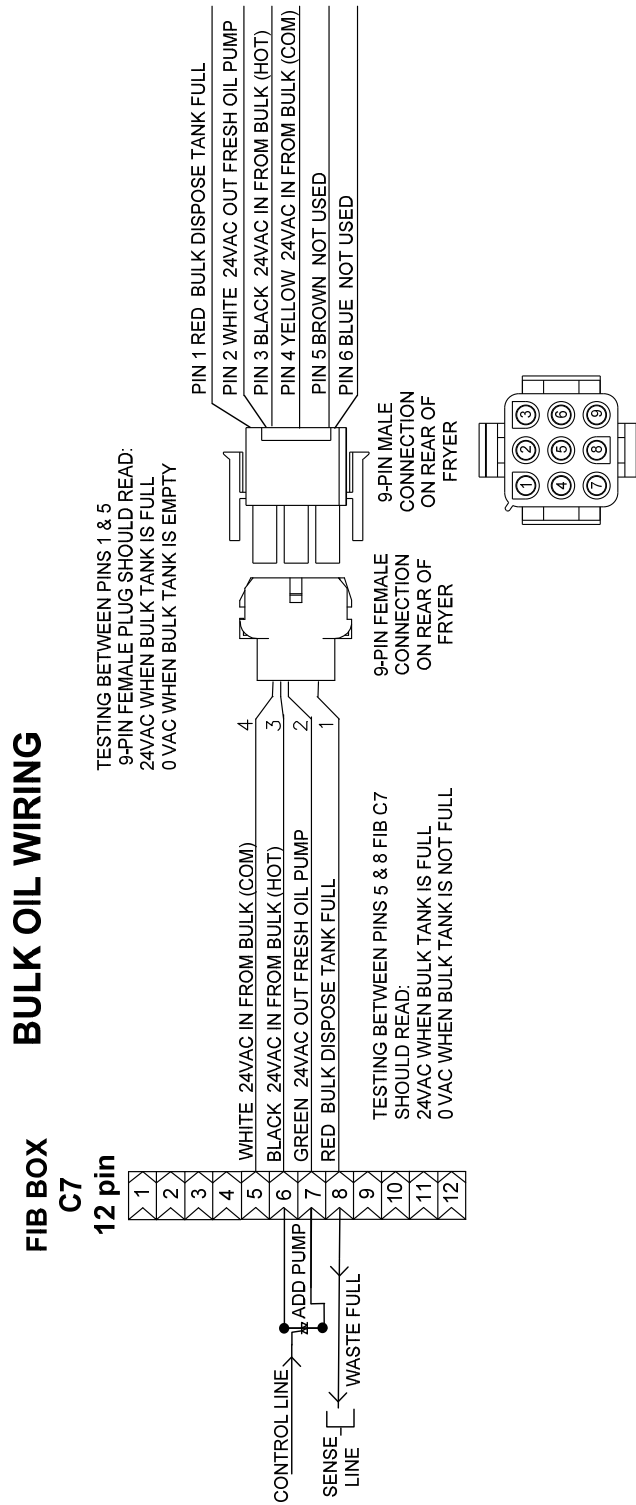

⚠ WARNING

The FQ30-T™ fryer will **ONLY** operate with bulk oil systems that have a three-pole float switch. If the float switch is the older two-pole switch, call the bulk oil provider. These float switches are polarity specific which may short to ground and damage an FIB board.

THIS PAGE INTENTIONALLY LEFT BLANK

Frymaster[®]

FRYMASTER
8700 LINE AVENUE, SHREVEPORT, LA 71106-6800

800-551-8633

318-865-1711

WWW.FRYMASTER.COM

EMAIL: FRYSERVICE@WELBILT.COM



Welbilt offers fully-integrated kitchen systems. Welbilt's portfolio of award-winning brands includes Cleveland™, Convotherm®, Crystal Tips®, Dean®, Delfield®, Fabristeel®, Frymaster®, Garland®, Inducs®, Koldtech®, Kolpak®, Lincoln®, McCann's™, Merco®, Merrychef®, Multiplex®, RDI®, SerVend™, SunFire®, U.S. Range™, and WMaxx™. Supported by service brands: FitKitchen®, kitchen systems; and KitchenConnect®, cloud-based open platform.

Bringing innovation to the table • welbilt.com

©2024 Frymaster LLC. except where explicitly stated otherwise. All rights reserved. Continuing product improvement may necessitate change of specifications without notice.

Part Number FRY_IOM_8197476 02/2024