

**FPD65, FPHD65, FPLHDC65 Series  
with Built-In Filtration**



**Frymaster FPHD65 Series  
Gas Fryers  
Installation & Operation Manual**

**Please read all sections of this manual and retain for future reference.**

***Frymaster***<sup>®</sup>



Frymaster, a member of the Commercial Food Equipment Service Association, recommends using CFESA Certified Technicians.

**24-Hour Service Hotline 1-800-551-8633**

**09/2023**



**NOTICE**

This appliance is intended for professional use only and is to be operated by qualified personnel only. A Frymaster Dean Factory Authorized Servicer (FAS) or other qualified professional should perform installation, maintenance, and repairs. Installation, maintenance, or repairs by unqualified personnel may void the manufacturer's warranty. See Chapter 1 of this manual for definitions of qualified personnel.

**NOTICE**

This equipment must be installed in accordance with the appropriate national and local codes of the country and/or region in which the appliance is installed. See NATIONAL CODE REQUIREMENTS in Chapter 3 of this manual for specifics.

**NOTICE**

Drawings and photos used in this manual are intended to illustrate operational, cleaning and technical procedures and may not conform to onsite management operational procedures.

**NOTICE TO OWNERS OF UNITS EQUIPPED WITH COMPUTERS**

**U.S.**

This device complies with Part 15 of the FCC rules. Operation is subject to the following two conditions: 1) This device may not cause harmful interference, and 2) This device must accept any interference received, including interference that may cause undesired operation. While this device is a verified Class A device, it has been shown to meet Class B limits.

**CANADA**

This digital apparatus does not exceed the Class A or B limits for radio noise emissions as set out by the ICES-003 standard of the Canadian Department of Communications.

Cet appareil numérique n'émet pas de bruits radioélectriques dépassant les limites de classe A et B prescrites dans la norme NMB-003 édictée par le Ministre des Communications du Canada.

**NOTICE**

IF, DURING THE WARRANTY PERIOD, THE CUSTOMER USES A PART FOR THIS FRYMASTER DEAN EQUIPMENT OTHER THAN AN UNMODIFIED NEW OR RECYCLED PART PURCHASED DIRECTLY FROM FRYMASTER DEAN, OR ANY OF ITS AUTHORIZED SERVICERS, AND/OR THE PART BEING USED IS MODIFIED FROM ITS ORIGINAL CONFIGURATION, THIS WARRANTY WILL BE VOID. FURTHER, FRYMASTER DEAN AND ITS AFFILIATES WILL NOT BE LIABLE FOR ANY CLAIMS, DAMAGES OR EXPENSES INCURRED BY THE CUSTOMER WHICH ARISE DIRECTLY OR INDIRECTLY, IN WHOLE OR IN PART, DUE TO THE INSTALLATION OF ANY MODIFIED PART AND/OR PART RECEIVED FROM AN UNAUTHORIZED SERVICER.

**NOTICE**

The Commonwealth of Massachusetts requires any and all gas products to be installed by a licensed plumber or pipe fitter.

**⚠ DANGER**

Improper installation, adjustment, maintenance or service, and unauthorized alterations or modifications can cause property damage, injury, or death. Read the installation, operating and service instructions thoroughly before installing or servicing this equipment. Only qualified service personnel may convert this appliance to use a gas other than that for which it was originally configured. See Chapter 1 of this manual for definition of qualified service personnel.

**⚠ DANGER**

Adequate means must be provided to limit the movement of this appliance without depending upon the gas line connection. Single fryers equipped with legs must be stabilized by installing anchor straps. All fryers equipped with casters must be stabilized by installing restraining chains. If a flexible gas line is used, an additional restraining cable must be connected at all times when the fryer is in use.

**⚠ DANGER**

The front ledge of the fryer is not a step. Do not stand on the fryer. Serious injury can result from slips or contact with the hot oil.

**⚠ DANGER**

Do not store or use gasoline or other flammable vapors and liquids in the vicinity of this or any other appliance.

**⚠ DANGER**

Instructions to be followed in the event the operator smells gas or otherwise detects a gas leak must be posted in a prominent location. This information can be obtained from the local gas company or gas supplier.

**⚠ DANGER**

The crumb tray in fryers equipped with a filter system must be emptied into a fireproof container at the end of frying operations each day. Some food particles can spontaneously combust if left soaking in certain shortening material. Additional information can be obtained in the filtration manual included with the system.

**⚠ WARNING**

No structural material on the fryer should be altered or removed to accommodate placement of the fryer under a hood. Questions? Call the Frymaster/Dean Service Hotline at 1-800-551-8633.

**⚠ WARNING**

Do not bang fry baskets or other utensils on the fryer's joiner strip. The strip is present to seal the joint between the frypot. Banging fry baskets on the strip to dislodge shortening will distort the strip, adversely affecting its fit. It is designed for a tight fit and should only be removed for cleaning.

# ***Frymaster***<sup>®</sup>

## **FPHD65 Series Gas Fryers Installation & Operation Manual**

### **TABLE OF CONTENTS**

	<b>Page #</b>
<b>1. INTRODUCTION</b> .....	<b>1-1</b>
<b>1.1 After Purchase</b> .....	<b>1-1</b>
<b>1.2 Ordering Parts</b> .....	<b>1-1</b>
<b>1.3 Service Information</b> .....	<b>1-1</b>
<b>1.4 Computer Information</b> .....	<b>1-1</b>
<b>1.5 Safety Information</b> .....	<b>1-2</b>
<b>1.6 Service Personnel</b> .....	<b>1-3</b>
<b>2. IMPORTANT INFORMATION</b> .....	<b>2-1</b>
<b>2.1 Receiving and Unpacking Equipment</b> .....	<b>2-1</b>
<b>2.2 General</b> .....	<b>2-2</b>
<b>2.3 Principles of Operation</b> .....	<b>2-3</b>
<b>2.4 Rating Plate</b> .....	<b>2-3</b>
<b>2.5 Pre-Installation</b> .....	<b>2-3</b>
<b>2.6 Air Supply and Ventilation</b> .....	<b>2-5</b>
<b>2.7 Equipment Installed at High Altitudes</b> .....	<b>2-5</b>
<b>3. INSTALLATION</b> .....	<b>3-1</b>
<b>3.1 Installing the Fryer</b> .....	<b>3-1</b>
<b>3.2 Gas Connections</b> .....	<b>3-4</b>
<b>3.3 Adjustments/Adaptation to Different Gases</b> .....	<b>3-7</b>
<b>3.4 Electrical Connections</b> .....	<b>3-9</b>
<b>4. FRYER OPERATIONS</b> .....	<b>4-1</b>
<b>4.1 Initial Start-up</b> .....	<b>4-1</b>
<b>4.2 Boil-Out Procedure</b> .....	<b>4-3</b>
<b>4.3 Final Preparation</b> .....	<b>4-5</b>

# ***Frymaster***<sup>®</sup>

## **FPHD65 Series Gas Fryers Installation & Operation Manual**

### **TABLE OF CONTENTS (CONT.)**

	<b>Page #</b>
<b>5. FILTRATION OPERATION</b> .....	<b>5-1</b>
<b>5.1 General</b> .....	<b>5-1</b>
<b>5.2 Filtration Preparation</b> .....	<b>5-1</b>
<b>5.3 Daily Filtration Operation</b> .....	<b>5-4</b>
<b>5.4 Operating the Filter</b> .....	<b>5-6</b>
<b>6. PREVENTATIVE MAINTENANCE</b> .....	<b>6-1</b>
<b>6.1 General</b> .....	<b>6-1</b>
<b>7. TROUBLESHOOTING</b> .....	<b>7-1</b>
<b>7.1 General</b> .....	<b>7-1</b>
<b>7.2 Pilot Burner Malfunction</b> .....	<b>7-2</b>
<b>7.3 Main Burner Malfunctions</b> .....	<b>7-2</b>
<b>7.4 Wiring Diagram, Main</b> .....	<b>7-4</b>
<b>7.5 Wiring Diagram, Filter</b> .....	<b>7-5</b>

# FRYMASTER FPHD65 SERIES GAS FRYERS

## CHAPTER 1: INTRODUCTION

---

### 1.1 After Purchase

In order to improve service, have the following chart filled in by the Frymaster/Dean Authorized Servicer who installed this equipment.

Authorized Servicer  
Technician/FAS  
Address

Telephone/Fax  
Model Number  
Serial Number  
Gas Type

---

---

---

---

---

---

---

---

### 1.2 Ordering Parts

Customers may order parts directly from their local factory authorized servicer. For this address and phone number, contact your factory authorized servicer or call the Frymaster/Dean Service Hotline phone number, 1-800-551-8633.

To speed up your order, provide the model number, serial number, gas type, part needed, item part number (if known), and quantity needed.

### 1.3 Service Information

Call the Frymaster/Dean Service Hotline, 1-800-551-8633, for the location of your nearest factory authorized servicer. To assist you more efficiently, always provide the service technician with the model number, gas type, serial number, and the nature of the problem.

### 1.4 Computer Information

This equipment has been tested and found to comply with the limits for a Class A digital device, pursuant to Part 15 of the FCC rules. While this device is a verified Class A device, it has been shown to meet the Class B limits. These limits are designed to provide reasonable protection against harmful interference when the equipment is operated in a commercial environment. This equipment generates, uses and can radiate radio frequency energy and, if not installed and used in accordance with the instruction manual, may cause harmful interference to radio communications. Operation of the equipment in a residential area is likely to cause harmful interference in which case the user will be required to correct the interference at his/her own expense.

# FRYMASTER FPHD65 SERIES GAS FRYERS

## CHAPTER 1: INTRODUCTION

---

### 1.4 Computer Information (cont.)

The user is cautioned that any changes or modifications not expressly approved by the party responsible for compliance could void the user's authority to operate the equipment.

If necessary, the user should consult the dealer or an experienced radio and television technician for additional suggestions.

The user may find the following booklet prepared by the Federal Communications Commission helpful: "How to Identify and Resolve Radio-TV Interference Problems". This booklet is available from the U.S. Government Printing Office, Washington, DC 20402, Stock No. 004-000-00345-4.

### 1.5 Safety Information

Before attempting to operate your unit, read the instructions in this manual thoroughly.

Throughout this manual, you will find notations enclosed in double-bordered boxes similar to the ones below.

 **CAUTION**

**CAUTION** boxes contain information about actions or conditions that *may cause or result in a malfunction of your system.*

 **WARNING**

**WARNING** boxes contain information about actions or conditions that *may cause or result in damage to your system,* and which may cause your system to malfunction.

 **DANGER**

**DANGER** boxes contain information about actions or conditions that *may cause or result in injury to personnel,* and which may cause damage to your system and/or cause your system to malfunction.

**FRYMASTER FPHD65 SERIES GAS FRYERS**  
**CHAPTER 1: INTRODUCTION**

---

## **1.6 Service Personnel**

### **1.6.1 Definitions**

#### **A. Qualified and/or Authorized Operating Personnel**

1. Qualified/authorized operating personnel are those who have carefully read the information in this manual and have familiarized themselves with the equipment functions, or have had previous experience with the operation of equipment covered in this manual.

#### **B. Qualified Installation Personnel**

1. Qualified installation personnel are individuals, or firms, corporations, or companies, which, either in person or through a representative are engaged in and are responsible for the installation of gas-fired appliances. Qualified personnel must be experienced in such work, be familiar with all gas precautions involved, and have complied with all requirements of applicable national and local codes.

#### **C. Qualified Service Personnel**

1. Qualified service personnel are those who are familiar with Frymaster/Dean equipment and have been authorized by Frymaster/Dean to perform service on Frymaster/Dean equipment. All authorized service personnel are required to be equipped with a complete set of service parts manuals and stock a minimum amount of parts for Frymaster/Dean equipment. A list of Frymaster Factory Authorized Servicers (FAS's) is located on the Frymaster website at [www.frymaster.com](http://www.frymaster.com). *Failure to use qualified service personnel will void the Frymaster/Dean warranty on your equipment.*

# FRYMASTER FPHD65 SERIES GAS FRYERS

## CHAPTER 2: IMPORTANT INFORMATION

---

### 2.1 Receiving and Unpacking Equipment

- A. Check that the containers are upright. Use an outward prying motion - *no hammering* - to remove the cartons. Unpack fryers carefully and remove all accessories from the carton and/or frypots. Do not discard or misplace accessories, as they will be needed during final assembly and fryer operation.
- B. After unpacking, immediately check the equipment for visible signs of shipping damage. If damage has occurred, contact the carrier and file the appropriate freight claims. Do not contact the factory. Shipping damage responsibility is between the carrier and the dealer.

#### **If your equipment arrives damaged:**

1. File claim for damages immediately, regardless of extent of damage.
2. Visible loss or damage: Be sure this is noted on the freight bill or express receipt and is signed by the person making the delivery.
3. Concealed loss or damage: If damage is unnoticed until equipment is unpacked, notify freight company or carrier immediately, and file a concealed damage claim. This should be done within 15 days of date of delivery. Be sure to retain container and all packing materials for inspection.

#### **NOTE: Frymaster/Dean Does Not Assume Responsibility for Damage or Loss Incurred in Transit.**

- C. **Built-in filtration cabinet:** Remove the filter pan from the cabinet before removing system from pallet.
- D. **Five- and Six-battery Frying Systems:** Units are shipped on two pallets. Casters are pre-installed on the frying system and unloading ramps are furnished to facilitate removal of the units off the pallets. Remove pallet supports from underneath fryer and carefully roll the unit down the ramps from the front (cooking side). **See assembly instructions shipped with unit for system assembly.**
- E. Remove all plastic skin from sides, front, and doors of the fryers. Units are shipped with plastic skin to protect the stainless components from surface damage during shipping. Failure to remove the plastic prior to initial fryer operation will make it very difficult to remove later.

**FRYMASTER FPHD65 SERIES GAS FRYERS  
CHAPTER 2: IMPORTANT INFORMATION**

---

## **2.2 General**

Qualified, licensed, and/or authorized installation or service personnel only (as defined in Section 1.6) should perform the following:

- **Installation and service on Frymaster/Dean equipment.**
- **Conversion of this appliance from one gas type to another.**

Failure to use qualified, licensed, and/or authorized installation or service personnel to install, convert to another gas type or otherwise service this equipment will void the Frymaster/Dean warranty and may result in damage to the equipment or injury to personnel.

Where conflicts exist between instructions and information in this manual and local code or national codes, or regulations, installation and operation shall comply with the codes or regulations in force in the country in which the equipment is installed.

 **DANGER**

**Building codes prohibit a fryer with its open tank of hot oil/shortening from being installed beside an open flame of any type, including those of broilers and ranges.**

Upon arrival, inspect the fryer carefully for visible or concealed damage. (See Receiving and Unpacking Equipment in Section 2.1.)

### **2.2.1 Product Description**

Frymaster FPHD65 Series gas fryers are energy efficient, tube-style, gas-fired units. All units are shipped completely assembled with accessories packed inside the frypot. Frymaster FPHD65 Series gas fryers are adjusted, tested and inspected at the factory before shipment. The input rates of this model are listed in this manual.

 **WARNING**

**The on-site supervisor is responsible for ensuring that operators are made aware of the inherent hazards of operating a hot oil frying system, particularly the aspects of system operation, oil filtration, draining and cleaning procedures.**

# FRYMASTER FPHD65 SERIES GAS FRYERS

## CHAPTER 2: IMPORTANT INFORMATION

---

### 2.3 Principles of Operation

The incoming gas flows through orifices and is mixed with air in the burners to create the correct ratio for proper combustion. The mixture is ignited at the front end of each heat tube by the pilot light. Internal diffusers slow the flame as it goes through the burner tube. This slower and more turbulent flame gives much better heat transfer to the walls of the tubes, thereby heating the oil better.

### 2.4 Rating Plate

This is attached to the inside front door panel. Information provided includes the model and serial number of the fryer, BTU/hr input of the burners, outlet gas pressure in inches W.C. and whether the unit has natural or propane gas orifices.

 **DANGER**

**Fryers *MUST* be connected *ONLY* to the gas type identified on the attached rating plate.**

### 2.5 Pre-Installation

 **DANGER**

**No structural material on the fryer should be altered or removed to accommodate placement of the fryer under a hood. Questions? Call the Frymaster/Dean Service Hotline at 1-800-551-8633.**

 **DANGER**

**Do not connect this appliance to the gas supply before reviewing all information in this chapter.**

- A. **General:** Only licensed personnel should install any gas-fired equipment.
1. A manual gas shut-off valve must be installed in the gas supply line ahead of the fryers for safety and ease of future service.
  2. Frymaster FPHD65 Series gas fryers require 120VAC 60 cycle or 230VAC single-phase 50-hertz (International/CE) electrical service and are equipped with a 16-3 SJT grounded flexible power cord for a direct connection to the power supply. Amperage draw for each unit depends on the accessories supplied with the unit/system.

**FRYMASTER FPHD65 SERIES GAS FRYERS**  
**CHAPTER 2: IMPORTANT INFORMATION**

---

**2.5 Pre-Installation (cont.)**

**B. Clearances:** The fryer area must be kept free and clear of all combustibles. This unit is design-certified for the following installations:

1. Commercial installation only (not for household use).
2. Non-combustible floor installation equipped with factory-supplied 6-inch (15-cm) adjustable legs or 5-inch (13-cm) casters;
3. Combustible construction with a minimum clearance of 6-inches (15-cm) side and 6-inches (15-cm) rear, and equipped with factory-supplied 5-inch (13-cm) casters.

**C. Installation Standards**

<p>1. <u>U.S. installations must meet:</u></p> <p>American National Standard Institute ANSI Z83.11 American Gas Association 8501 E. Pleasant Valley Road Cleveland, OH 44131</p> <p>National Electrical Code ANSI/NFPA #70 American National Standard Institute 1430 Broadway New York, NY 10018</p> <p>NFPA Standards #96 and #211 National Fire Protection Association 470 Atlantic Avenue Boston, MA 02110</p>	<p>2. <u>Canadian installations must meet:</u></p> <p>CAN 1-B149 Installation Codes Canadian Gas Association 55 Scarsdale Road Don Mills, ONT, M3B 2R3</p> <p>Canadian Electric Code c22.1, part 1 Canadian Standards Association 178 Rexdale Blvd. Rexdale, ONT, M9W 1R3</p>
---	---

**NOTICE**

**The Commonwealth of Massachusetts requires any and all gas products to be installed by a licensed plumber or pipe fitter.**

**FRYMASTER FPHD65 SERIES GAS FRYERS**  
**CHAPTER 2: IMPORTANT INFORMATION**

---

## **2.6 Air Supply and Ventilation**



**This appliance must be installed with sufficient ventilation to prevent the occurrence of unacceptable concentrations of substances harmful to the health of personnel in the room in which it is installed.**

Keep the area around the fryer clear to prevent obstruction of combustion and ventilation airflow as well as for service and maintenance.

- A. Do not connect this fryer to an exhaust duct.
- B. Correct installation and adjustment will ensure adequate airflow to the fryer system.
- C. A commercial, heavy-duty fryer must vent its combustion wastes to the outside of the building. A deep-fat fryer must be installed under a powered exhaust hood, or an exhaust fan must be provided in the wall above the unit, as exhaust gas temperatures are approximately 800-1000°F (427-538°C). Check air movement during installation. Strong exhaust fans in the exhaust hood or in the overall air conditioning system can produce slight air drafts in the room.
- D. Do not place the fryer's flue outlet directly into the plenum of the hood, as it will affect the gas combustion of the fryer.
- E. Never use the interior of the fryer cabinet for storage or store items on shelving over or behind the fryer. Exhaust temperatures can exceed 800°F (427°C) and may damage or melt items stored in or near the fryer.
- F. Adequate distance must be maintained from the flue outlet of the fryer(s) to the lower edge of the filter bank. When installing any type of fryer, Standard No. 96 of the National Fire Protection Association must be followed implicitly.
- G. Filters and drip troughs should be part of any industrial hood but consult local codes before constructing and installing any hood. The duct system, the hood and filter bank must be cleaned on a regular basis and kept free of grease according to the NFPA Standard No. 96. A copy of the standard may be obtained from the National Fire Protection Association, Battery March Park, Quincy, MA 02269 or at [www.NFPA.org](http://www.NFPA.org).

## **2.7 Equipment Installed at High Altitudes**

- A. The fryer input rating (BTU/hr) is for elevations up to 2,000 feet (610-m). For elevations above 2,000 feet (610-m), the rating should be reduced four percent for each additional 1,000 feet (305-m) above sea level.
- B. The correct orifices are installed at the factory if operating altitude is known at time of the customer's order.

# FRYMASTER FPHD65 SERIES GAS FRYERS

## CHAPTER 3: INSTALLATION

### 3.1 Installing the Fryer

Decathlon 65 Series fryer systems are shipped in sections. The fryers are uncrated, removed from pallets and assembled together. Important aspects during assembly include aligning and connecting the drain system, oil return system, rinse-line system (where applicable), oil-return switch wiring harness and fryer cabinets. Slight modifications to connecting hardware may be required when assembling the system. The instructions below provide step-by-step instructions to assist the installer in assembly.

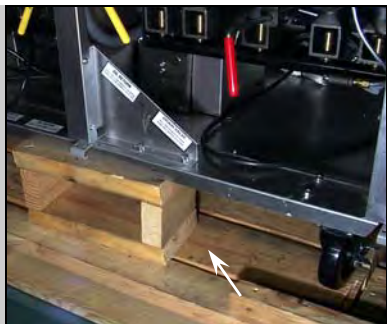

**Figure 1:** Remove pallet supports (arrow) before removing fryers from pallets.



**Figure 2:** A center-mounted caster and its extended mounting plate is shown at left. The other section of the fryer is lifted onto the plate and secured with provided bolts.



**Figure 3:** Connecting drain safety wiring.



**Figure 4:** Align the fryers and secure the center mounting plate with bolts.

1. Open the doors of the filtration fryer cabinet. Remove filter pan from the cabinet. Uncrate fryers and remove the pallet supports. Install ramps and slowly roll the fryer(s) off the pallets. **See Figure 1.**
2. Remove covers over openings in the cabinet to access the oil return and drain plumbing as well as safety drain wiring also in the rear opening.
3. Remove the lower back from the two-vat unit and to gain access to the oil return line.
4. Remove the right-side door from the larger unit, which allows access to the drain manifold.
5. With the fryer near its installation site, roll the two pieces to within a few inches of each other. Do not connect the fryers to power.
6. Connect the color-coded drain wiring with the attached connector. The wiring is accessible in the oil return opening at the rear of the fryer. **See Figure 3.**
7. Position the flex return line and roll the units closer together. The flex hose should align with the threaded nipple.
8. Connect the flex line and tighten.

## FRYMASTER FPHD65 SERIES GAS FRYERS

### CHAPTER 3: INSTALLATION



**Figure 5:** Clamp the fryers together to facilitate mounting securing brackets.

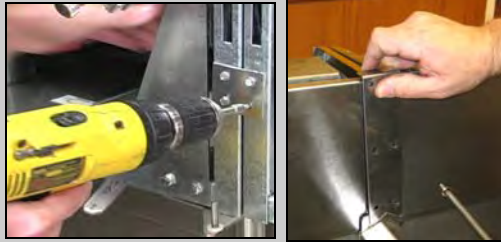

**Figures 7,8:** Use screws to attach securing brackets. Ensure the rear bracket screws go through the vertical stiffening channel. Attach the flue cap joiner strip at the back of the frypot.



**Figure 6:** Attach strip joining the fryer sections. Install screws under the lower edge.



**Figure 9:** Place joiner strip which connects the frypots.

9. Use a pry bar to lift the non-filter side of the fryer onto the extended caster plate. **See Figure 2.**
10. Install the bolts in the center caster mounting plate. Leave the brackets in place. **See Figure 4.**
11. Use a clamp to hold the units tightly together at the front and rear for the remaining steps. **See Figure 5.**
12. Attach the strip, which joins the top caps. Seal with hi-temp silicon. Two screws secure the strip at the front. **See Figure 6.**
13. With the fryers still clamped together, mount joining brackets front and back. **See Figures 7, 8.**
14. Attach the flue-cap connecting bracket. **See Figures 7, 8.**
15. Extend the boot from one drain manifold to the other, tightening it with the attached clamp.
16. Reattach the lower panel on the two-vat unit.
17. Attach the gas manifolds.
18. Replace the door.
19. Remove plastic covering the stainless panels as the fryer is assembled.
20. Seal seam between fryer halves with hi-temp silicon.
21. Place the joiner strip, which aligns the fryers at the frypot. **See Figure 9.**
22. Add the basket hanger to the flue over the frypot to be used for french fries.
23. Add the splash guard to the end vat if needed.
24. Return fryer to hood and ensure computers are set for the required menu items.
25. Remove bezel, lower computer and insert menu strip appropriate for the computer setting.
26. Reinstall filter pan after fryer start-up has been performed (boil-out, burner adjustment, etc.) **NEVER ALLOW WATER OR BOILOUT SOLUTION INTO FILTER SYSTEM.**
27. **Check all connections for leaks. Ensure all components operate properly.**

**FRYMASTER FPHD65 SERIES GAS FRYERS  
CHAPTER 3: INSTALLATION**

---

### 3.1 Installing the Fryer (cont.)

 **DANGER**

**Fryers must be at room temperature and empty of oil during movement to avoid damage and possible bodily injury.**

 **DANGER**

**Hot shortening can cause severe burns. Avoid contact. Under all circumstances, oil must be removed from the fryer before attempting to move it to avoid oil spills, and the falls and severe burns that could occur. This fryer may tip and cause personal injury if not secured in a stationary position.**

### 3.2 Gas Connections

 **DANGER**

**Before connecting new pipe to this appliance the pipe must be blown out thoroughly to remove all foreign material. Foreign material in the burner and gas controls will cause improper and dangerous operation.**

#### NATIONAL CODE REQUIREMENTS

This equipment is to be installed in compliance with the Basic Plumbing Code of the Building Officials and Code Administrators International, Inc. (BOCA) and the Food Service Sanitation Manual of the U.S. Food and Drug Administration.

This equipment is manufactured to use the type of gas specified on the rating plate attached to the door. Connect equipment stamped "NAT" only to natural gas and that stamped "PRO" only to LP (Propane) gas.

**Notice**

**Installation shall be made with a gas connector that complies with national and local codes. Quick disconnect devices, if used, shall likewise comply with national and local codes.**

 **DANGER**

**The fryer MUST be connected to the gas supply specified on the rating and serial number plate located on the back of the fryer door.**

**FRYMASTER FPHD65 SERIES GAS FRYERS**  
**CHAPTER 3: INSTALLATION**

---

### 3.2 Gas Connections (cont.)

** DANGER**

**If gas odors are detected, the gas supply MUST be shut off at the main shut-off valve. The local gas company or FAS should be contacted immediately to rectify the problem.**

- A. The gas supply (service) line must be the same size or greater than the fryer inlet line. This fryer system is equipped with three 1" (28 mm) female inlets (one inlet per two fryers). The gas supply line must be sized to accommodate all the gas-fired equipment that may be connected to that gas supply. Consult your contractor, gas company, supplier, or other knowledgeable authorities.

**Recommended Gas Supply Line Sizes**

Gas Types	Number of Fryers		
	1	2 to 3	4 or more (*)
Natural Gas	3/4" (22 mm)	1" (28 mm)	1-1/4" (35 mm)
Propane Gas	1/2" (15 mm)	3/4" (22 mm)	1" (28 mm)

(\*) When exceeding 18 feet for a configuration of more than four fryers, it is necessary to provide a 1-1/4" (35 mm) rigid gas connection.

** DANGER**

**All connections must be sealed with a joint compound suitable for the gas being used and all connections must be tested with a solution of soapy water before lighting any pilots.**

**Never use matches, candles, or any other ignition source to check for leaks. If gas odors are detected, shut off the gas supply to the appliance at the main shut-off valve and immediately contact the local gas company or an authorized service agency for service.**

** DANGER**

**"Dry-firing" your unit will cause damage to the frypot and can cause a fire. Always ensure that melted shortening, cooking oil or water is in the frypot before firing the unit.**

- B. Rigid Connections: Check any installer-supplied intake pipe(s) visually and clean threading chips, or any other foreign matter before installing into a service line. If the intake pipes are not clear of all foreign matter, the orifices will clog when gas pressure is applied. Seal pipe joints with a sealant resistive to LP gas. When using thread compound on gas piping, use very small amounts and only on male threads. Use a pipe thread compound that is not affected by the chemical action of LP gases. **DO NOT** apply thread compound to the first two pipe threads—doing so will cause clogging of the burner orifices and control valve.

**FRYMASTER FPHD65 SERIES GAS FRYERS**  
**CHAPTER 3: INSTALLATION**

---

### **3.2 Gas Connections (cont.)**

- C. Manual shut-off valve: This gas service supplier-installed valve must be installed in the gas service line ahead of the fryers in the gas stream and in a position where it can be reached quickly in the event of an emergency.
- D. Regulating Gas Pressure: The fryer and shut-off valve must be disconnected from the gas supply during any pressure testing of the system.
1. External gas regulators are not normally required on this fryer. A safety control valve protects the fryer against pressure fluctuations. If the incoming pressure is in excess of ½" PSI (3.45 kPa/35 mbar), **a step-down regulator will be required.**

 **DANGER**

**When pressure-testing incoming gas supply lines, disconnect the fryer from the gas line if the test pressure is ½" PSI [3.45 kPa (14 inches W.C.)] or greater to avoid damage to the fryer's gas piping and gas valve(s).**

- E. Manifold Pressure: Your local service technician should check the manifold pressure with a manometer.
1. Check the rating plate for specific manifold gas pressures. Natural gas units normally require 4" W.C., and propane units normally require 11" W.C. gas pressure.
  2. Double check the arrow forged into the bottom of the regulator body, which shows gas flow direction. It should point downstream towards the fryers. The air vent cap is also part of the regulator and should not be removed.
  3. If a vent line from the gas pressure regulator is used, it should be installed in accordance with local codes or in the absence of local codes, with the National Fuel Gas Code, ANSI Z223.1-(latest edition).

 **WARNING**

**Use a diluted soap solution to find potentially dangerous gas leaks when making new connections.**

- F. Regulators can be adjusted in the field, but it is recommended that they not be unless the part is known to be out of adjustment or serious pressure fluctuations are found to exist and can be solved no other way.
- G. Only qualified service personnel should make adjustments to the regulators.
- H. Orifices: The fryer can be configured to operate on any available gas. The correct safety control valve, appropriate gas orifices, and pilot burner are installed at the factory. While the valve can be adjusted in the field, only qualified service personnel should make any adjustments with the proper test equipment.

**FRYMASTER FPHD65 SERIES GAS FRYERS**  
**CHAPTER 3: INSTALLATION**

---

### **3.2 Gas Connections (cont.)**

I. Flexible Couplings, Connectors and Casters:

1. If the fryer is to be installed with flexible couplings and/or quick-disconnect fittings, the installer must use a heavy-duty AGA design-certified commercial flexible connector of at least 1" NPT (with suitable strain reliefs), in compliance with the Standard for Connectors for Movable Gas Appliances, ANSI Z21.69-(latest edition) and Addenda Z21.69a-(latest edition). Quick disconnect devices must comply with the Standard for Quick-Disconnect Devices for Use with Gas Fuel, ANSI Z21.41-(latest edition).

 **WARNING**

**Do not attach accessories to this fryer unless fryer is secured from tipping.  
Personal injury may result.**

2. The fryer must be restrained by means independent of the flexible coupling or connector in order to limit the movement of the fryer. Clips are located on the back panel of the fryer for the attachment of restraints.
3. If disconnection of the restraint is necessary, this restraint must be reconnected after the fryer has been returned to its originally installed position.

J. After hook-up, bleed the gas line of air to ensure that the pilot light will ignite quickly.

### **3.3 Adjustments/Adaptation To Different Gases**

A. Proper operation of Frymaster/Dean gas fryers requires operator to inspect the following adjustments in terms of:

1. Gas inputs and pressures.
2. Voltage and polarities of electrical power supplies.

B. Frymaster/Dean gas fryers are manufactured to use the type of gas and pressure specified on the rating plate. When changing to a different gas, **adaptation must be performed by qualified personnel**. Failure to use qualified personnel will void the Frymaster/Dean warranty.

**FRYMASTER FPHD65 SERIES GAS FRYERS**  
**CHAPTER 3: INSTALLATION**

---

### 3.3.1 Specifications

#### 3.3.1.1 Adjustments to Different Gas Types

<b>Gas Adjustments</b>		
<b>Gas Type</b>	Natural	LP
<b>Manifold Pressure†</b>	4" W.C.*/10 mbar*	11" W.C.*/27.5 mbar*
<b>Orifice Diameter</b>	Model Specific	Model Specific
<b>Burner Marking</b>	None	None
<b>Pilot Marking</b>	26N (P/N 810-0811)	16LP (P/N 810-2400)
<small>* Gas pressure may vary per fryer model and altitude. <b>Check the rating plate for specific gas pressures.</b></small>		

NOTE: Outlet gas pressure must be adjusted strictly within the above requirements 5 to 10 minutes after the appliance is operating.

† For controls and adjustments, please refer to the "gas valve" illustration on page 3-9. (Pilot Flame Adjustment: Turn the pilot adjustment screw clockwise/counter-clockwise until the desired flame-volume is achieved.)

### 3.3.2 Gas Conversion Procedures

 **DANGER**

**This appliance was configured at the factory for a specific type of gas. Converting from one gas type to another requires the installation of specific gas-conversion components.**

**Switching to a different type of gas without installing the proper conversion components may result in fire or explosion. NEVER ATTACH THIS APPLIANCE TO A GAS SUPPLY FOR WHICH IT IS NOT CONFIGURED!**

**Conversion of this appliance from one type of gas to another should only be performed by qualified, licensed, and authorized installation or service personnel, as defined in Section 1.6 of this manual.**

## FRYMASTER FPHD65 SERIES GAS FRYERS CHAPTER 3: INSTALLATION

### 3.3.2 Gas Conversion Procedures (cont.)

Contact factory with the following information when performing conversions:

- Fryer Serial Number
- Fryer Model Number
- Gas Type
- Operating Altitude

**Conversions can only be executed by qualified, factory-authorized personnel.**

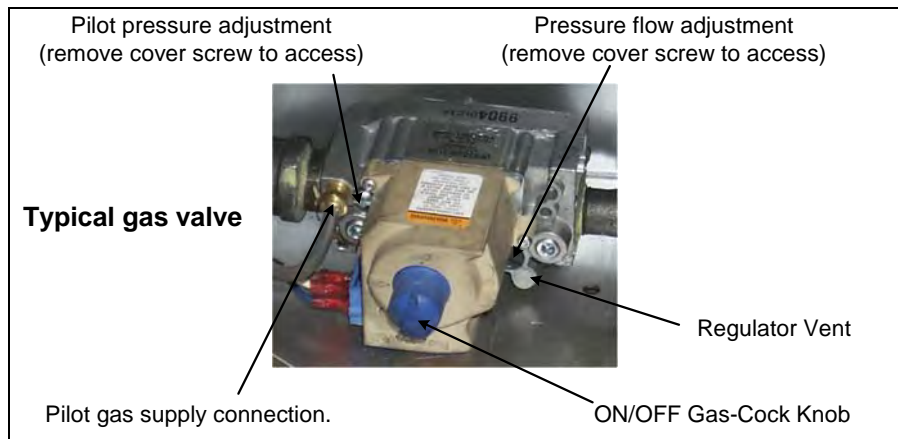

### 3.4 Electrical Connections

The fryer when installed must be electrically grounded in accordance with local codes, or in the absence of local codes, with the National Electrical Code, ANSI/NFPA 70-(latest edition).

#### **⚠ DANGER**

**This fryer is equipped with three-prong (grounding) plugs for protection against electrical shock and must be plugged directly into a properly grounded, three-prong receptacle. DO NOT CUT, REMOVE, OR OTHERWISE BYPASS THE GROUNDING PRONGS ON THESE PLUGS!**

The rating plate and wiring diagram are located inside the front door. The fryer is equipped with a 120VAC single-phase 60-hertz system (Domestic), or 230VAC single-phase 50-hertz system (International/CE). Do not cut or remove the ground prong from any of the power cord plugs. Do not attempt to use the fryer during a power outage.

#### **⚠ DANGER**

**This appliance requires electrical power for operation. Place the gas control valve in the OFF position in case of a prolonged power outage. Do not attempt to operate this appliance during a power outage.**

# FRYMASTER FPHD65 SERIES GAS FRYERS

## CHAPTER 4: FRYER OPERATIONS

---

### 4.1 Initial Start-up

#### WARNING

The on-site supervisor is responsible for ensuring that operators are made aware of the inherent hazards of operating a hot oil frying system, particularly the aspects of system operation, oil filtration, draining and cleaning procedures.

Cleaning: New units are wiped clean with solvents at the factory to remove any visible signs of dirt, oil, grease, etc. remaining from the manufacturing process, then coated lightly with oil. Before any food preparation, wash thoroughly with hot, soapy water to remove any film residue and dust or debris then rinse out and wipe dry. Also wash any accessories shipped with the unit. Close the drain valve completely and remove the crumb screen covering the heating tubes. Ensure the screws holding the thermostat and high-limit control sensing bulbs into the frypot are tight.



Typical high-limit/sensor probe locations and mounting hardware.

#### WARNING

Do not bang fry baskets or other utensils on the fryer's joiner strip. The strip is present to seal the joint between the frypot. Banging fry baskets on the strip to dislodge shortening will distort the strip, adversely affecting its fit. It is designed for a tight fit and should only be removed for cleaning.

#### DANGER

Never operate this appliance with an empty frypot. The frypot must be filled with water or cooking oil/shortening before lighting the burners. Failure to do so will damage the frypot and may cause a fire.

#### WARNING

When checking for burner ignition or performance, do not get too close to the burners. Slow ignition can cause possible flashback, increasing the potential for facial and body burns.

## FRYMASTER FPHD65 SERIES GAS FRYERS

### CHAPTER 4: FRYER OPERATIONS

---

#### 4.1.1 Pilot Lighting Procedures, Electronic Ignition Systems

Initial Pilot Lighting: All Frymaster/Dean fryers are tested, adjusted and calibrated to sea level conditions before leaving the factory. Adjustments to assure proper operation of pilot may be necessary on installation to meet local conditions, low gas pressure, differences in altitude and variations in gas characteristics. These adjustments correct possible problems caused by rough handling or vibration during shipment, and are to be performed only by qualified service personnel. These adjustments are the responsibility of the customer and/or the dealer and are not covered by the Frymaster/Dean warranty.

The inlet pipe at the lower rear of the fryer brings incoming gas to the pilot safety control valve, then to the pilot and main burners. The pilot is located high in the cabinet center, at the base of the frypot.

 **WARNING**

**Never use a match or taper to light pilot on this ignition system.**

1. Turn gas "ON".
2. Turn electric power "ON" with the appropriate rocker switch or controller/computer.
3. The ignition module will energize the pilot gas supply and the ignitor. The ignitor spark will ignite the pilot gas. The presence of the pilot flame is then proved by a flame sensor, which sends a signal to the main gas supply, opening the valve. The operating thermostat or computer/controller controls the fryer after ignition.

 **WARNING**

**In the event of prolonged power failure, the ignition module will shut down and lock out the system. Turn the unit power "OFF" and them back "ON" after power has been re-established.**

4. If the pilot flame fails, the ignition module will shut down and lock out the system. To restart, turn the electric power "OFF", wait approximately 5 minutes for the system to recycle itself, then turn the power "ON" again. Repeat Steps 1-3.

**FRYMASTER FPHD65 SERIES GAS FRYERS**  
**CHAPTER 4: FRYER OPERATIONS**

---

## 4.2 Boil-Out Procedure

 **DANGER**

Never leave the fryer unattended during the boil-out process. If the boil-out solution boils over, turn the fryer off immediately and let the solution cool for a few minutes before resuming the process. To lessen the chance of boil over, turn the fryer's gas valve knob to the PILOT position occasionally.

 **WARNING**

Do not drain boil-out solution into a shortening disposal unit, a built-in filtration unit, or a portable filter unit. These units are not intended for this purpose, and will be damaged by the solution.

 **DANGER**

Remove all drops of water from the frypot before filling with cooking oil or shortening. Failure to do so will cause spattering of hot liquid when the oil or shortening is heated to cooking temperature and may cause injury to nearby personnel.

- A. Pour cleaning solution into the frypot and add water to the bottom OIL LEVEL line scribed in the back of the frypot.
- B. Operating thermostat-equipped fryers: Set dial/temperature controller to 225°F (107°C), just above that of boiling water.
- C. Filtration/Boil-Mode equipped fryers: Turn fryer power switch to "ON". Press the fryer-reset switch (if applicable). Turn the boil-out switch "ON".

 **CAUTION**

If the pilot and main burner go out, the fryer(s) **MUST** be left completely shut down at least 5 minutes before lighting.

- D. The main burner will ignite.
- E. When the solution nears boiling point, reset the temperature controller to 200°(93°C).
- F. The burners should shut off just as the water starts to boil.

 **CAUTION**

Do not leave fryer unattended. The boil-out solution may foam and overflow if fryer is left unattended. Press ON/OFF switch to the "OFF" position (Filtration/Boil-Mode equipped fryers) or reduce temperature (Operating Thermostat equipped fryers) to control this condition.

**FRYMASTER FPHD65 SERIES GAS FRYERS**  
**CHAPTER 4: FRYER OPERATIONS**

---

## 4.2 Boil-Out Procedure (cont.)

- G. The burners will heat the boil-out solution to a simmer. Simmer the solution for approximately 45 minutes. Wearing protective gloves, scrub the sides of the frypot and the tubes with the L-shaped Teflon brush, being careful not to disturb the temperature sensing probes and the high-limit thermostat.
- H. Do not allow the water level to decrease below the bottom OIL LEVEL line in frypot during boil-out operation.

 **WARNING**

**Water or boil-out solution MUST not be allowed to drain into the filter pan or filter system. Irreversible damage will result if water is allowed into the system.**

- I. After boil out is complete, turn the computer off. Drain the solution from the frypot. Place a metal stockpot of sufficient size to safely hold the entire contents of the frypot under the drain port to collect the water/boil-out solution. Do not allow water or boil-out solution to drain into the filter pan. The filter pump is not designed for water operation, and will be irreparably damaged (see warning statement above).
- J. Close the drain, add fresh water (without boil-out solution) and wash all surfaces of the frypot. Drain again.
- K. Refill the frypot with fresh water and vinegar to neutralize any residual boil-out solution. Wash all surfaces of the frypot. Drain completely and wipe down all surfaces of the frypot to completely remove all water.

**Computer-equipped fryers: See computer manual for boil-out programming and follow the above procedures for boil-out.**

 **DANGER**

**Do not go near the area directly over the flue outlet while the fryer is operating.**

**Always wear oil-proof, insulated gloves when working with the fryer filled with hot oil.**

**Always drain hot oil into a metal stockpot of sufficient size to safely hold the entire contents of the frypot.**

**FRYMASTER FPHD65 SERIES GAS FRYERS**  
**CHAPTER 4: FRYER OPERATIONS**

---

### **4.3 Final Preparation**

 **WARNING**

**NEVER set a complete block of solid shortening on top of heating tubes. To do so will damage the heating tubes and frypot, and void the warranty.**

#### **4.3.1 Filling Fryer with Cooking Oil/Shortening**

- A. When using a liquid shortening (cooking oil), fill the fryer to the bottom OIL LEVEL line scribed into the back of the frypot.
- B. When using a solid shortening, cut it into small pieces and pack it below the heat tubes, between the tubes and on top of the tubes, leaving no air spaces around the tubes. Do not disturb or bend the probe sensing bulbs.
- C. Press the computer on/off switch to "ON". The burners will initially operate in the MELT CYCLE mode until the shortening reaches 180°F. It will then automatically switch to normal operation.
- D. When the frypot is filled and the shortening is melted, carefully replace the crumb screen over the heat tubes. Wear oil-proof insulated gloves to avoid the potential for burn injury when placing crumb screen in frypot.

**For additional computer instructions, see computer manual that came with frying system.**

# FRYMASTER FPHD65 SERIES GAS FRYERS

## CHAPTER 5: FILTRATION OPERATION

### WARNING

Drawings and photos used in this manual are intended to illustrate operational, cleaning and technical procedures and may not conform to on-site management operational procedures.

### 5. 1 General

Most SUFF/UFF systems use filter paper as the filter medium. Some filter systems can be special ordered with a filter-leaf assembly, which eliminates the need for filter paper. Both types require the use of filter powder to enhance the filtration process. Photos used in the procedural illustrations may differ from the filter unit that came with the frying system. The following procedures apply to all fryers equipped with SUFF/UFF filter systems. Filter system design depends on the frying system configuration.

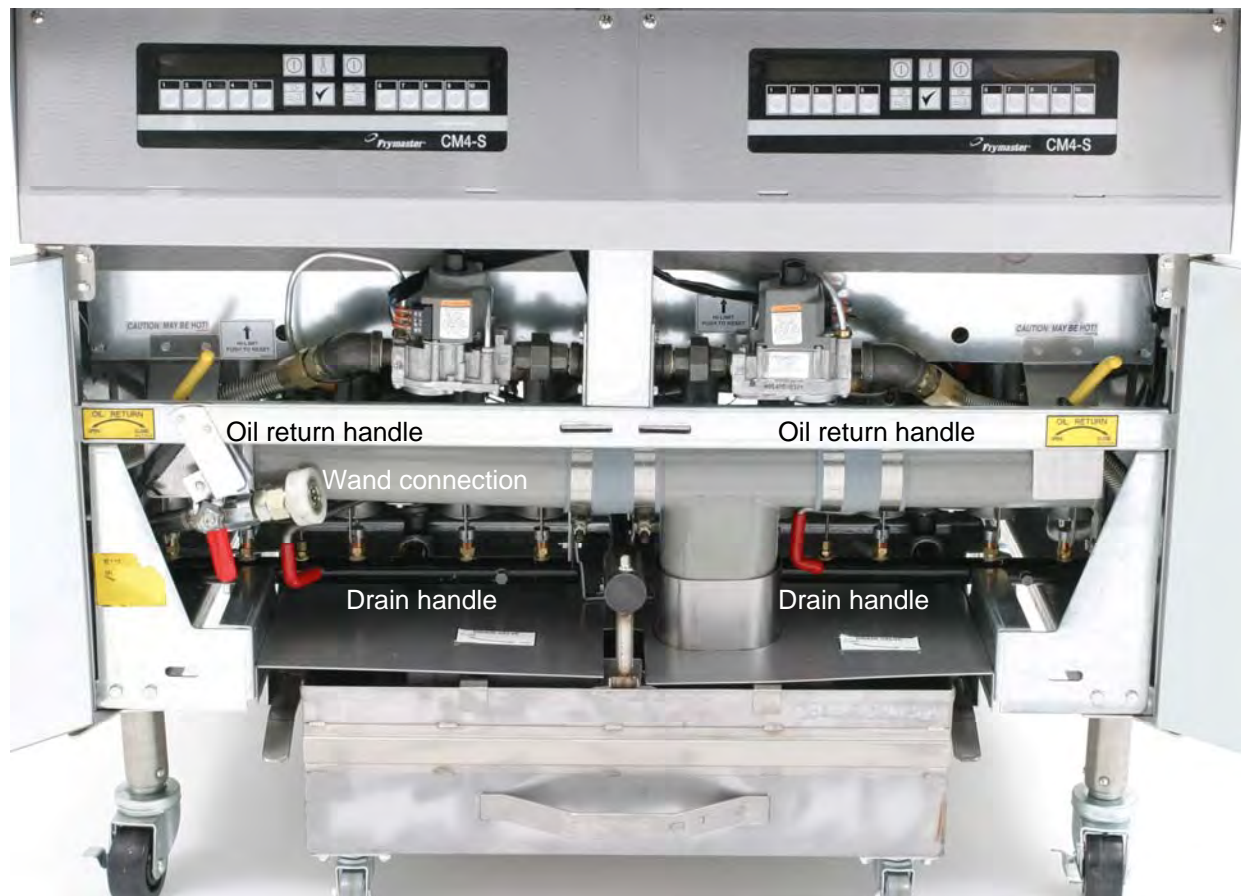

FPHD265 cabinet interior

# FRYMASTER FPHD65 SERIES GAS FRYERS

## CHAPTER 5: FILTRATION OPERATION

### 5.3 Filter Preparation

On initial installation and before each use, clean the filter:

- a. remove all loose parts from the filter,
- b. wash the filter pan and all accessories in hot, soapy water,
- c. and dry thoroughly.

#### 5.3.2 Filter Unit Types

##### FILTER PAPER AND HOLD DOWN RING

Filter paper is held in place by a hold-down ring. Oil moves through the paper, leaving behind impurities.

1. Filter pan.
2. Filter support grid.
3. Filter paper.
4. Hold-down ring.
5. Crumb screen.

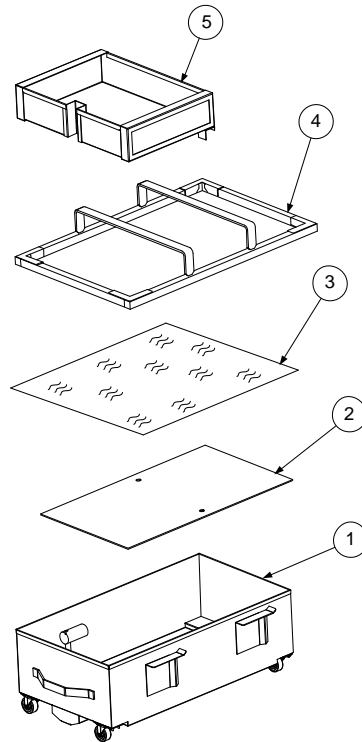

A filter unit which utilizes disposable filter paper to filter oil.

**FRYMASTER FPHD65 SERIES GAS FRYERS**  
**CHAPTER 5: FILTRATION OPERATION**

**5.2.2 Filter Unit Types (cont.)**

**FILTER LEAF**

A filter leaf is a fine mesh screen which is reusable and takes the place of disposable paper. Oil moves through the leaf, leaving behind impurities.

1. Filter pan.
2. Filter leaf.
3. Crumb Screen.
4. Caster.

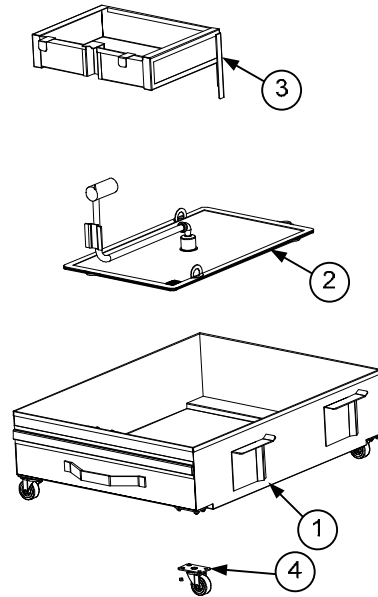

A filter unit which utilizes a filter leaf to filter the oil.

# FRYMASTER FPHD65 SERIES GAS FRYERS

## CHAPTER 5: FILTRATION OPERATION

### 5.2.3 Assembling the Filter

#### FILTER PAPER AND HOLD DOWN RING

1. Place the support grid in the bottom of filter pan.



Support grid properly placed in filter pan.

2. Put one filter paper sheet on top of the support grid. Be sure the paper covers the filter pan bottom and laps two inches onto the pan wall.



Ensure filter paper overlaps two inches on all sides and is evenly distributed under the hold-down ring.

3. Position the hold-down ring on top of the filter paper. Ensure the hold-down ring seals around the support grid. This prevents air from getting into the system.



Hold-down ring positioned correctly over filter paper in filter pan.

# FRYMASTER FPHD65 SERIES GAS FRYERS

## CHAPTER 5: FILTRATION OPERATION

---

### 5.2.4 Assembling the Filter (cont.)

4. Sprinkle 8 ounces (227g) of filter powder on the filter sheet. Ensure the powder covers the filter paper evenly.



Sprinkle the proper amount of filter powder evenly over the paper.

5. Place the crumb screen in the filter pan. Allow the crumb screen to rest on the top edges of the hold-down ring.



Crumb screen properly placed.

6. Return filter pan to cabinet. Ensure the pickup tube is solidly connected to the fryer.

# FRYMASTER FPHD65 SERIES GAS FRYERS

## CHAPTER 5: FILTRATION OPERATION

### 5.2.5 Assembling the Filter (cont.)

#### FILTER LEAF

1. Remove the filter pan from the fryer by pulling out on the filter pan handle.



Pull out on the handle to remove the filter pan.

2. Remove the crumb basket by lifting it up and out of the filter pan. Be careful not to damage the tubes or connectors in the pan.



Remove the crumb screen by lifting it up and out.

3. Remove the filter leaf by lifting up on the pickup tube and raising the filter leaf assembly gently out of the filter pan.

4. Clean the filter leaf assembly, crumb screen, and pan with warm soapy water. Thoroughly rinse and dry.

5. When it is clean, place the filter leaf carefully back into the filter pan.

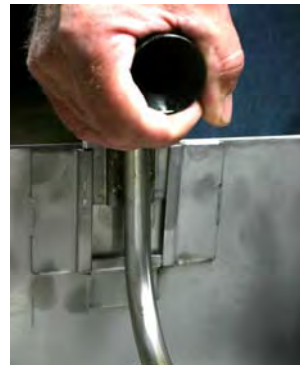

Carefully remove the filter leaf assembly.

**FRYMASTER FPHD65 SERIES GAS FRYERS**  
**CHAPTER 5: FILTRATION OPERATION**

---

**5.2.6 Assembling the Filter (cont.)**

6. Sprinkle 8 ounces (227g) of filter powder on the filter leaf. Ensure the powder covers the mesh evenly.

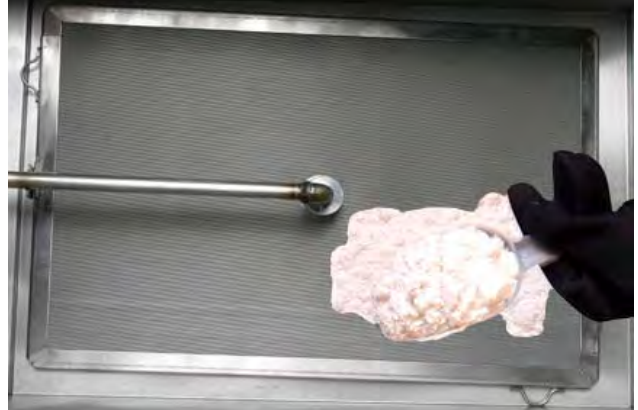

Applying filter powder to filter-leaf.

7. Replace the crumb tray in the pan after filter powder application.



Crumb screen properly placed in filter pan.

8. Return the filter pan to the fryer cabinet. Ensure the pickup tube is solidly connected.

# FRYMASTER FPHD65 SERIES GAS FRYERS

## CHAPTER 5: FILTRATION OPERATION

### 5.2.7 Installing the Filter

- Slide the filter inside the fryer cabinet. Ensure the male-female pickup tubes are fully engaged. Ensure the filter pan opening is directly under the center dump tube.



The filter pan slides under the fryer (left), connecting with a male connector (right). Ensure that the pickup tube is securely coupled with this connector. Its location may vary based on model.

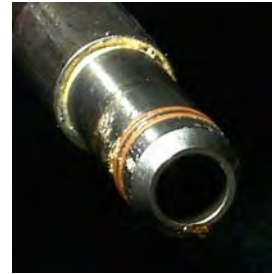

### 5.3 Daily Filter Operation

#### **WARNING**

**Use caution and wear proper protective clothing. The oil to be filtered is at or near 350°F (177°C). Ensure all hoses are connected properly and drain handles are in their proper position prior to operating any switches or valves. Failure to do this can result in severe burns.**

#### **WARNING**

**Drawings and photos used in this manual are intended to illustrate operational, cleaning and technical procedures and may not conform to on-site management operational procedures.**

#### 5.3.1 General Overview

Only filter oil at operating temperature (~350°F/~177°C). When filtering begins, the filter motor engages and oil is drawn through filter paper or a filter-leaf assembly and pumped back into the frypot through oil return plumbing or an optional filter wand. The frypot's drain remains open during the filtering process, allowing oil to filter through the frypot and back into the filter unit. Allow the oil to cycle through this process for approximately 5 minutes. At the end of 5 minutes, close the drain valve and allow the frypot to fill to the top OIL LEVEL line. Leave the pump running for 10-15 seconds after bubbles appear in the frypot or the optional wand sputters to ensure all oil is pumped from the drain pan and the lines. Close the oil return valve and, if an optional filter wand is used, press the wand toggle switch to OFF position.

## FRYMASTER FPHD65 SERIES GAS FRYERS

### CHAPTER 5: FILTRATION OPERATION

---

#### 5.3.2 Filtering Tools

Assemble tools to be used for filtering. These are supplied with the filter starter kit included with the fryer/filter system:

- Frypot/Filter Brush - used to clean frypot and filter pan sides and bottom, heating elements, and to dislodge sediment during filtration or oil change.
- Clean-out Rod (design may vary) - used to dislodge heavy debris in the drain tube (when needed).
- Filter Powder.
- Filter Paper (not used in filter-leaf equipped filter systems).

The following tools are not required, but are recommended to make the filtering task easier.

- Measuring Cup - used to measure filter powder.
- Stainless Steel Crumb Scoop - for removing large debris from oil prior to filtering.

**Note: Always wear oil-resistant, insulated gloves and/or protective gear when working with hot oil.**

# FRYMASTER FPHD65 SERIES GAS FRYERS

## CHAPTER 5: FILTRATION OPERATION

### 5.4 Operating the Filter

#### 5.4.1 Pan Preparation and Operation

See Section 6.2.1, *Assembling the Filter*, and Section 6.2.2, *Installing the Filter*, for the appropriate filter preparation procedure. For optional filter hose and wand, see Section 6.4.3, *Optional Filter Hose and Wand Operation*.

**⚠ CAUTION**

**NEVER operate the filter unit unless cooking oil is at operating temperature (~350°F/ ~177°C).**

1. Ensure the filter pan assembly is prepared as described in Section 6.2.1, *Assembling the Filter*, and ensure fryer is turned off.
2. Remove fry baskets from frypot and skim any large debris from the oil. Use extreme caution, as oil is at or near operating temperature (~350°F/~177°C).



Prior to filtering, skim any large debris from oil in frypot.

3. Remove the support grid from the frypot using the clean-out rod. Stir the oil with the frypot/filter brush to suspend debris prior to draining.



Removing support grid from fry vessel prior to filtering.

# FRYMASTER FPHD65 SERIES GAS FRYERS

## CHAPTER 5: FILTRATION OPERATION

### 5.4.2 Pan Preparation and Operation (cont.)

4. After ensuring the filter pan is correctly positioned under the drain tubes, move the red handle to the open position (right) to drain the frypot into the filter pan. **Drain ONLY one frypot at a time. The filter pan is designed to hold the contents of one frypot only.**



Move the red drain valve handle into the open position.

5. After all oil has drained from the frypot into the filter pan, pull the yellow handle to open the oil return lines and activate the filter pump. Leave the red handle in the open position.



Push the yellow handle to open the oil return valve and activate the filter pump.

# FRYMASTER FPHD65 SERIES GAS FRYERS

## CHAPTER 5: FILTRATION OPERATION

### 5.4.3 Filter Operation

- Oil will begin to pump from the filter pan into the frypot. If the frypot tubes, sides and bottom have sediment deposits, clean the frypot with the cleaning brush included with the fryer. Clean beneath and under the burner tubes, using care not to disturb the probes (arrow).



Clean all sediment and suspended particles from the burner tubes and frypot as the oil begins to circulate. Use care not to disturb the probes (arrow) on the burner tube.

- Allow the oil to circulate for approximately 5 minutes (process known as "polishing") to remove suspended particles.

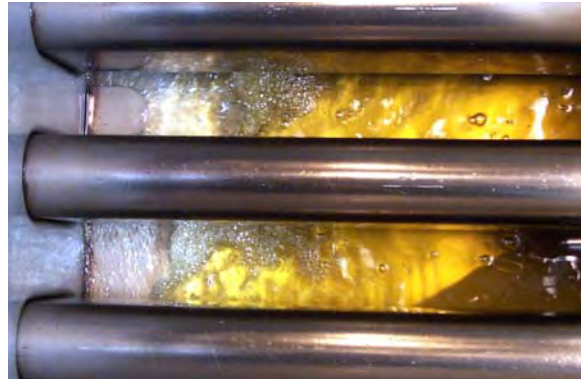

Polishing the oil removes suspended particles, which increases the life of the oil.

- After the filter cycle is complete, close the drain valve (push the red handle to the left until it stops) and allow the fryer to refill (see Step 4 above for additional reference).



After filtering is complete, close the red drain handle to start refilling the frypot.

# FRYMASTER FPHD65 SERIES GAS FRYERS

## CHAPTER 5: FILTRATION OPERATION

### 5.4.4 Filter Operation (cont.)

9. After all oil is pumped back into the frypot, bubbles will form, indicating air in the oil return lines. Allow the oil to bubble for 10-15 seconds to ensure all oil is evacuated from the return lines. Push the yellow handle to close the oil return valve and deactivate the filter pump (see Step 5 above for additional reference).



Allow the oil to bubble for 10-15 seconds to ensure evacuation of all oil in the return lines.

10. If the oil level is low, add oil until the level is at the top OIL LEVEL line.

**DO NOT OVERFILL THE FYPOT. This will cause oil to splash out of the frypot during cooking and may cause burns or damage.**



Add oil/shortening until the oil level is at the top OIL LEVEL line. DO NOT OVERFILL THE FRYPOT.

11. Replace the frypot grid, using care not to splash hot oil. Turn the fryer on.



Replace the frypot grid, using care not to splash hot oil.

**DECATHLON SERIES GAS FRYERS**  
**CHAPTER 5: UNDER FRYER FILTER (SUFF/UFF) FILTRATION**

---

**5.4.5 Filter Operation (cont.)**

12. Do not allow crumbs to accumulate in the crumb tray. The crumb tray **MUST** be emptied into a fireproof container at the end of frying operations **EACH DAY** (see **DANGER** statement below).



Empty the filter pan crumb tray into a fire-proof container at the end of frying operations each day. **DO NOT ALLOW CRUMBS TO ACCUMULATE IN TRAY.**

**⚠ DANGER**

**The crumb tray in fryers equipped with a filter system must be emptied into a fireproof container at the end of frying operations each day. Some food particles can spontaneously combust if left soaking in certain shortening material.**

**⚠ WARNING**

**Do not bang fry baskets or other utensils on the fryer's joiner strip. The strip is present to seal the joint between the fry vessels. Banging fry baskets on the strip to dislodge shortening will distort the strip, adversely affecting its fit. It is designed for a tight fit and should only be removed for cleaning.**

# FRYMASTER FPHD65 SERIES GAS FRYERS

## CHAPTER 5: FILTRATION OPERATION

### 5.5 Optional Filter Hose and Wand Operation

Some frying systems come equipped with an optional filter hose, wand, and toggle switch to facilitate the removal of debris from the frypot. The hose attaches to a quick-disconnect in the fryer cabinet.

1. Ensure the oil is at operating temperature (~350°F/~177°C). Turn the fryer off and open the fryer drain valve. Allow the oil to drain into the filter pan.



Moving the red drain valve handle to open the drain valve, allowing hot oil to drain into the filter pan.

2. When all the oil has drained from the frypot, connect the hose/wand assembly to the quick-disconnect under the fryer cabinet. Ensure the hose is properly connected before proceeding.
3. Open the blue-handled Wand/Disposal valve in the cabinet above the quick disconnect.



Optional hose/wand quick-disconnect.

**NOTE:** Rocker switch will not operate the hose/wand if the wand/disposal valve (blue handle) is closed.

4. Place the wand into the open frypot and activate the filter with the wand/disposal switch (rocker switch) on the front of the cabinet.

**DO NOT PROCEED UNLESS THE WAND IS INSIDE THE FRYPOT.** Hot oil can immediately flow from the wand when it is attached, causing burns if the wand is not in the frypot.



Open the wand/disposal valve (left). Use the rocker switch (above) to send oil through the hose.

# FRYMASTER FPHD65 SERIES GAS FRYERS

## CHAPTER 5: FILTRATION OPERATION

### 5.6 Hose and Wand Operation (cont.)

5. The oil will start to flow immediately into the frypot. **Keep the wand inside the frypot at all times while the filter pump is activated.**
6. Rinse debris from the frypot into the filter pan with the wand.
7. When cleanup is complete, press the wand/disposal switch to OFF, close the drain valve (red handle) and close the wand/disposal valve with the blue handle.
8. Disconnect the hose/wand from the fryer.
9. Lift the quick-disconnect end of the hose/wand and drain excess oil into the frypot.
10. Store the hose/wand in its designated location.

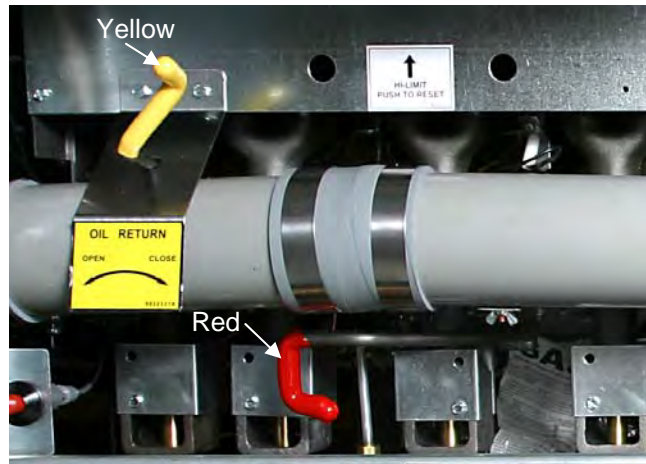

The red handle is attached to the drain valve. The yellow handle is attached to the oil return valve.



Use the optional wand to rinse debris from the frypot into the filter pan. Maintain a firm grip on the wand handle at all times.

### 5.7 Complete Filtering

1. Refill the frypot by rotating the yellow handle to open the oil-return valve and activate the filter pump.
2. After the frypot refills, allow the oil to bubble for 10-15 seconds to ensure evacuation of all oil from the oil return lines. Rotate the yellow handle to close the oil-return valve and stop the filter pump. Filtration is complete. Filter another frypot or return the fryer to operation.



Return filtered oil to the frypot by rotating the yellow handle to open oil return valve.

# FRYMASTER FPHD65 SERIES GAS FRYERS

## CHAPTER 6: PREVENTIVE MAINTENANCE

---

### 6.1 General

 **DANGER**

**Never attempt to clean the fryer during the cooking process or when the frypot is filled with hot oil/shortening. If water comes in contact with oil/shortening heated to cooking temperature, it will cause spattering of the oil/shortening, which can result in severe burns to nearby personnel.**

Any equipment works better and lasts longer when maintained properly and kept clean. Cooking equipment is no exception. Frymaster FPHD65 Series gas fryers should be kept clean during the working day, and thoroughly cleaned at the end of each day. Below are recommendations for daily, weekly and periodic preventative maintenance.

#### 6.1.1 Daily

 **WARNING**

**Use a commercial grade cleaner formulated to effectively clean and sanitize food-contact surfaces. Read the directions and precautionary statements for use. Particular attention must be paid to the concentration of cleaner and the length of time the cleaner remains on the food-contact surfaces.**

- A. Remove and wash all removable parts.
- B. Clean all exterior surfaces of the cabinet. Do not use cleaners, steel wool, or any other abrasive material on stainless steel.
- C. Filter the cooking oil and replace if necessary. The oil should be filtered more frequently when under heavy use.
- D. Clean filter pan, as well as, crumb tray as discussed on page 5-9.

#### 6.1.2 Weekly

- A. Completely drain the oil from the fryer into a metal stockpot of sufficient size to safely hold the entire contents of the frypot for disposal. Do not use a glass or plastic container.
- B. Clean the frypot by following boil-out procedures in Chapter 4.2.

 **WARNING**

**Never allow water to boil down and expose the heating tubes. Frypot damage will result.**

## FRYMASTER FPHD65 SERIES GAS FRYERS

### CHAPTER 6: PREVENTIVE MAINTENANCE

---

#### 6.1.3 Periodic/ Annual

The fryer should be inspected and adjusted periodically by qualified service personnel as part of a regular kitchen maintenance program.

Frymaster/Dean recommends that the fryer be inspected at least annually by a Factory Authorized Servicer as follows:

- Inspect fryer cabinet inside and out, front and rear, for excessive oil build-up and/or oil migration. Verify that burners and associated components (i.e. gas valves, pilot assemblies, ignitors, etc.) are in good condition and functioning properly. Inspect all gas connections for leaks and ensure all connections are properly tightened.
- Verify that temperature and high-limit probes are properly connected, tightened and functioning properly.
- Verify all component box components (i.e. computer/controller, relays, transformers, interface boards, etc.) are in good condition and free from oil migration build-up and other debris. Inspect component box wiring and ensure all connections are tight and all wiring is in good condition. Ensure all safety features (i.e. drain safety switches, reset switches, etc.) are present and functioning properly.
- Verify that frypot is in good condition and free of leaks. Verify that frypot tube diffusers are present and in good condition (i.e. no visible deterioration or damage).
- Verify that all wiring and connections are tight and in good condition.

#### **Built-in Filtration:**

- Inspect all oil-return and drain lines for leaks and verify that all connections are tight.
- Inspect the filter pan for leaks and cleanliness. If there is a large accumulation of crumbs in the crumb basket, advise the owner/operator that the crumb basket should be emptied into a fireproof container and cleaned daily.
- Verify that all O-rings and seals (including those on quick-disconnect fittings) are present and in good condition. Replace O-rings and seals if worn or damaged.

## FRYMASTER FPHD65 SERIES GAS FRYERS

### CHAPTER 6: PREVENTIVE MAINTENANCE

---

#### 6.1.3 Periodic/ Annual (cont.)

- Check filtration system integrity as follows:
  - With the filter pan empty, place each oil return handle, one at a time, in the "ON" position. Verify that the pump activates and that bubbles appear in the cooking oil/shortening of the associated frypot.
  - Close all oil return valves (i.e., place all oil return handles in the "OFF" position). Verify proper functioning of each oil return valve by activating the filter pump using the lever on one of the oil return handle microswitches. No air bubbles should be visible in any frypot.
  - Verify that the filter pan is properly prepared for filtering, then drain a frypot of oil heated to 350°F (177°C) into the filter pan and close the frypot drain valve. Place the oil return handle in the "ON" position. Allow all cooking oil/shortening to return to the frypot (indicated by bubbles in the cooking oil/shortening). Return the oil return handle to the "OFF" position. The frypot should refill in no more than 2 minutes and 30 seconds.

**To ensure good fryer health and a safe environment, the fryer should be checked and adjusted periodically by qualified service personnel as part of a regular kitchen maintenance program.**

#### 6.1.4 Stainless Steel Care



**DO NOT let water splash into the tank of hot oil. It will splatter and can cause severe burns.**

All stainless steel fryer cabinet parts should be wiped regularly with hot, soapy water during the day, and with a liquid cleanser designed for stainless steel at the end of each day.

- A. Do not use steel wool, abrasive cloths, cleansers or powders.
- B. Do not use a metal knife, spatula or any other metal tool to scrape stainless steel! Scratches are almost impossible to remove.
- C. If it is necessary to scrape the stainless steel to remove any encrusted materials, soak the area first to soften the deposit, then use a wood or nylon scraper only.

# FRYMASTER FPHD65 SERIES GAS FRYERS

## CHAPTER 7: TROUBLESHOOTING

---

### 7.1 General

 **DANGER**

**Hot cooking oil/shortening will cause severe burns. Never attempt to move this appliance when filled with hot cooking oil/shortening or to transfer hot cooking oil/shortening from one container to another.**

 **DANGER**

**This equipment should be unplugged when servicing, except when electrical circuit tests are required. Use extreme care when performing such tests.**

**This appliance may have more than one electrical power supply connection point. Disconnect all power cords before servicing.**

**Inspection, testing and repair of electrical components should be performed by an authorized service agent only.**

The problems and possible solutions covered are those most commonly encountered. To troubleshoot, perform the test set-up at the beginning of each condition. Follow each step in sequence.

### 7.2 Pilot Burner Malfunction

- A. Pilot will not ignite; no evidence of gas at pilot burner.
  - 1. Check that gas valve is open and gas is present at the gas valve.
  - 2. Check pilot burner orifice for dirt or lint.
  - 3. Factory Authorized Servicer Only: Remove pilot burner gas-supply line and check for contamination; blow out if necessary, then reinstall.
  
- B. Pilot burner ignites but will not remain lit when gas valve manual knob is released.
  - 1. Check that thermopile lead is properly connected at the terminal block on the gas valve.
  - 2. Factory Authorized Servicer Only: Pilot flame may be too high or too low. Adjust pilot flame adjustment screw so that pilot flame extends about 3/4-inch (19-mm) above the top of the pilot burner.

**FRYMASTER FPHD65 SERIES GAS FRYERS**  
**CHAPTER 7: TROUBLESHOOTING**

---

## **7.2 Pilot Burner Malfunction (cont.)**

3. Check all connections for cleanliness and security.
- C. Pilot flame of proper size, but is unstable. Flame wavers and does not envelop the thermopile completely at all times.
1. Check for drafts that might be caused by air conditioning equipment or make-up air apparatus. Turn air-moving equipment off and recheck the pilot.

## **7.3 Main Burner Malfunctions**

- A. Main burner will not come "ON"; gas not detected at main burner.
1. Check that the gas valve is open.
  2. Check that the pilot is ignited and is operating properly.
  3. Factory Authorized Servicer Only: Check the high-limit switch for continuity.
  4. Factory Authorized Servicer Only: Check the combination gas valve and replace if defective.
- B. Main burner flames are small and appear lazy; shortening does not come up to temperature quickly.
1. Factory Authorized Servicer Only: Check gas pressure at the pressure tap of the gas valve. Use dial type or standard water-type U-gauge manometer. With burner in operation, the pressure should be 4" W.C. (10 mbar) for natural gas, and 11" W.C. (27.5 mbar) for propane. If not, remove the pressure regulator adjustment cover. Use screwdriver to turn the adjusting screw for proper pressure. Replace cover, re-check pressure and re-install pressure tap plug.
- C. Signs of excessive temperature; shortening scorches and quickly becomes discolored.
1. Check operating thermostat. May be out of adjustment or calibration. Recalibrate if necessary.
  2. Check gas pressure as outlined above.
  3. Shortening used is of inferior quality and/or shortening has been used too long. Replace shortening.
  4. Ensure frypot is clean when refilling with new shortening.

**FRYMASTER FPHD65 SERIES GAS FRYERS**  
**CHAPTER 7: TROUBLESHOOTING**

---

**7.3 Main Burner Malfunctions (cont.)**

- D. Fryer will not reach the temperature setting and/or runs erratically.
  - 1. Incorrect location of sensor probe or defective temperature sensor.
  - 2. Loose wiring/wire connection
- E. Fryer shortening temperature cannot be controlled; fryer runs at high-limit temperature.
  - 1. Defective temperature probe; Call Factory Authorized Servicer.

# FRYMASTER FPHD65 SERIES GAS FRYERS

## CHAPTER 7: TROUBLESHOOTING

### 7.4 Wiring Diagram, Main

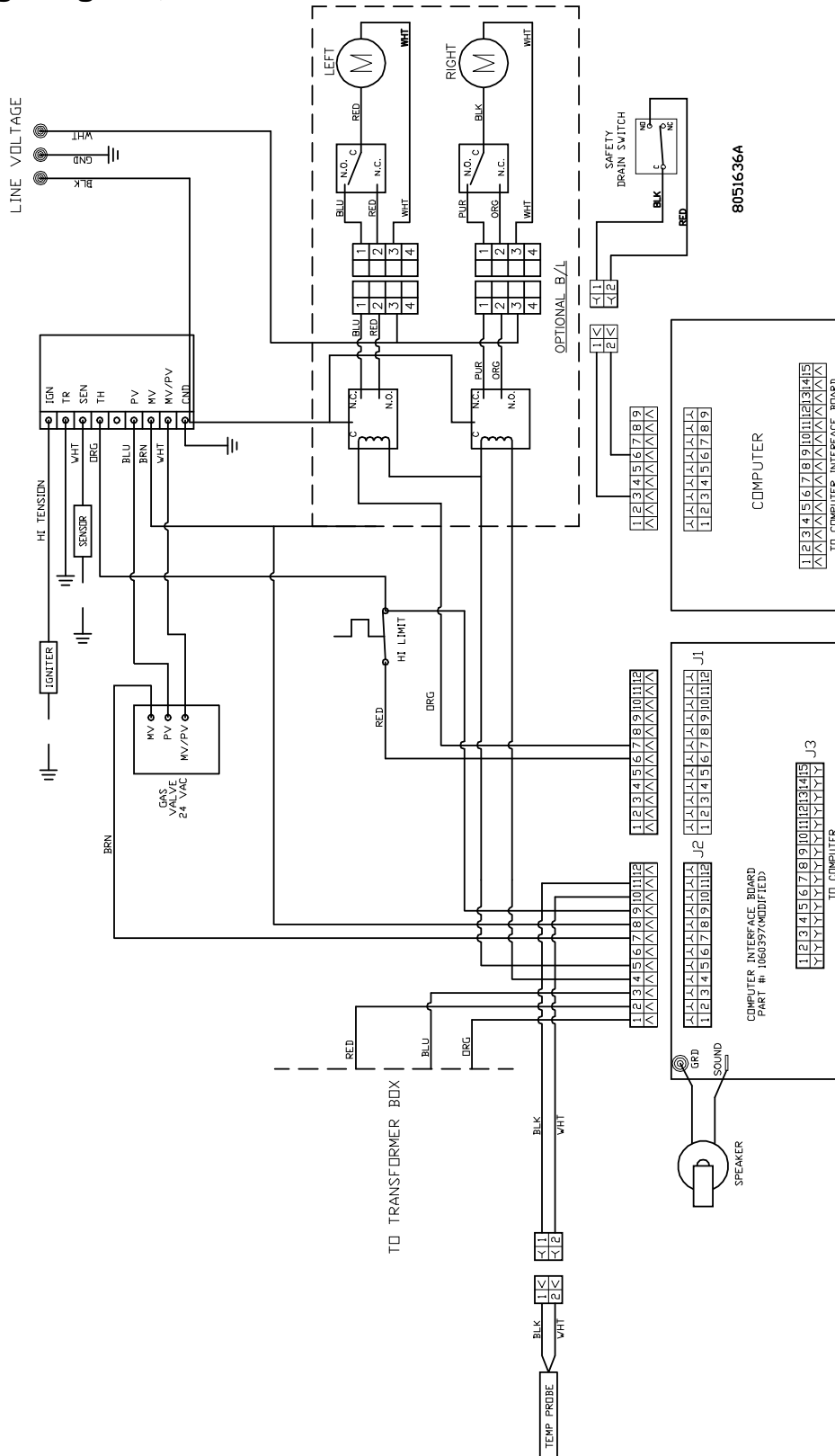

# FRYMASTER FPHD65 SERIES GAS FRYERS

## CHAPTER 7: TROUBLESHOOTING

### 7.5 Wiring Diagram, Filter

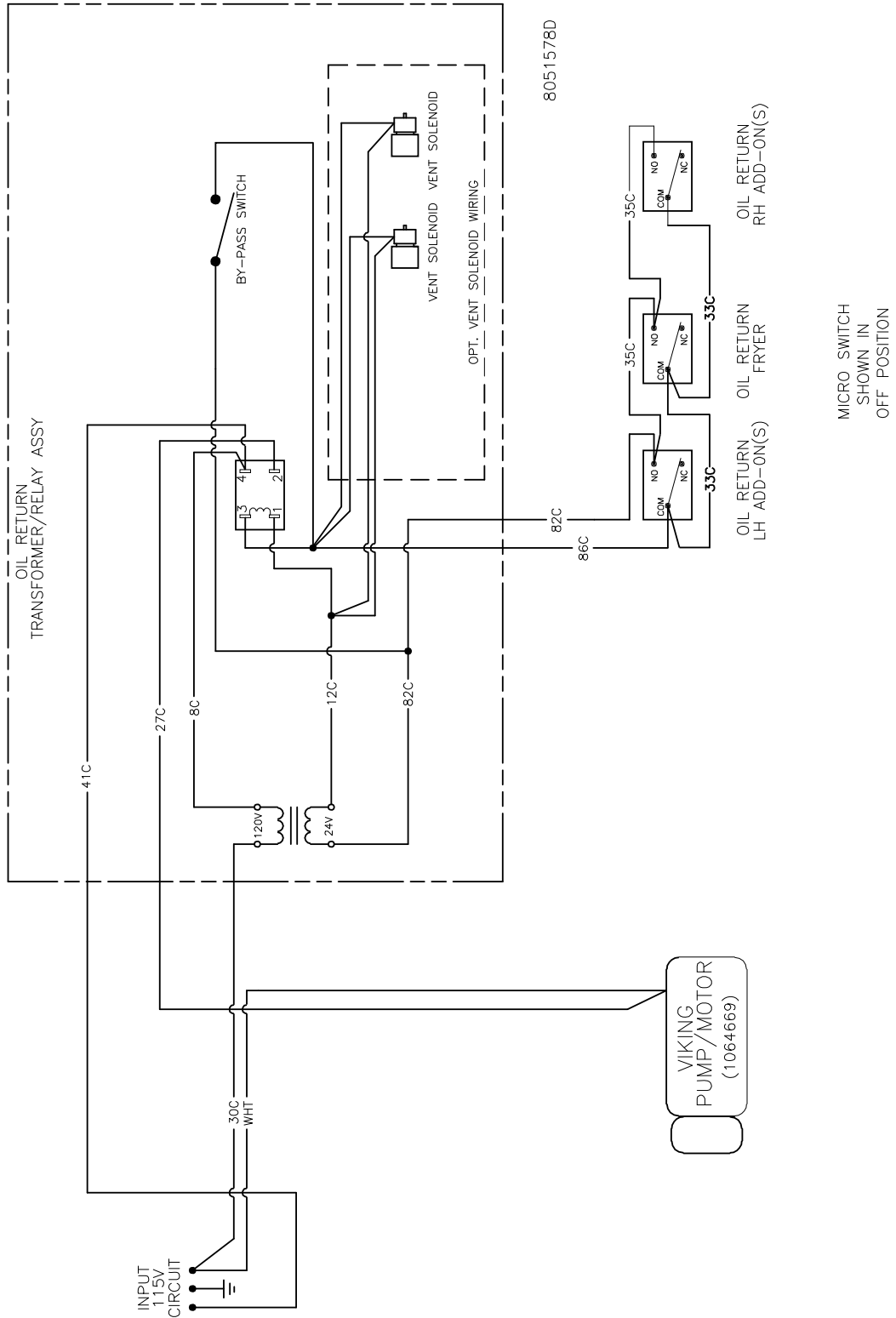



Welbilt offers fully-integrated kitchen systems. Welbilt's portfolio of award-winning brands includes Cleveland™, Convotherm®, Crystal Tips®, Dean®, Delfield®, Fabristeel®, Frymaster®, Garland®, Inducs®, Koldtech®, Kolpak®, Lincoln®, McCann's™, Merco®, Merrychef®, Multiplex®, RDI®, SerVend™, SunFire®, U.S. Range™, and WMaxx™. Supported by service brands: FitKitchen®, kitchen systems; and KitchenConnect®, cloud-based open platform.

*Bringing innovation to the table* • [welbilt.com](http://welbilt.com)