

FilterQuick™ FQGLA-T Gas Fryer (Serial #'s 1703-1712)

Parts Manual

This manual is updated as new information and models are released. Visit our website for the latest manual.



FOR YOUR SAFETY

Do Not Store or use gasoline or other flammable vapors and liquids in the vicinity of this or any other appliance.



8 1 9 7 4 4 6

Part Number: FRY_P_8197446 05/2024

Original Instructions

NOTICE

IF, DURING THE WARRANTY PERIOD, THE CUSTOMER USES A PART FOR THIS FRYMASTER DEAN EQUIPMENT OTHER THAN AN UNMODIFIED NEW OR RECYCLED PART PURCHASED DIRECTLY FROM FRYMASTER DEAN, OR ANY OF ITS FACTORY AUTHORIZED SERVICERS, AND/OR THE PART BEING USED IS MODIFIED FROM ITS ORIGINAL CONFIGURATION, THIS WARRANTY WILL BE VOID. FURTHER, FRYMASTER DEAN AND ITS AFFILIATES WILL NOT BE LIABLE FOR ANY CLAIMS, DAMAGES OR EXPENSES INCURRED BY THE CUSTOMER WHICH ARISE DIRECTLY OR INDIRECTLY, IN WHOLE OR IN PART, DUE TO THE INSTALLATION OF ANY MODIFIED PART AND/OR PART RECEIVED FROM AN UNAUTHORIZED SERVICER.

Table of Contents

CHAPTER 1: Parts List

1.1	Accessories.....	1-1
1.2	Doors, Sides, Flue Caps, Top Caps and Casters.....	1-2
1.3	Drain System Components.....	1-3
1.4	Electronics and Electrical Components.....	1-4
1.4.1	Component Boxes and Associated Components.....	1-4
1.4.2	Power Distribution Boxes	1-5
1.4.3	ATO (Automatic Top Off)/FIB (Filter Interface Board) /Filter Box Components.....	1-6
1.4.4	VIB (Valve Interface Board) Components	1-7
1.4.5	Power Reset Switch and USB Connector	1-7
1.5	Wiring.....	1-8
1.5.1	Main Wiring Harnesses SIB J1 to Components	1-8
1.5.2	Ignition Wiring Harnesses SIB J2 to Components	1-9
1.6	Frypots and Associated Components.....	1-10
1.6.1	Full-Vat Frypot Components	1-10
1.6.2	Dual-Vat Frypot Components	1-12
1.6.3	Frypot Assemblies and Associated Parts	1-14
1.7	Oil Return Manifolds	1-15
1.8	Gas Supply and Combustion System Components	1-16
1.9	Gas Valves and Associated Components.....	1-17
1.10	Filtration System Components	1-19
1.10.1	Filter Pan, Pump, Motor, etc.	1-19
1.10.2	Oil Quality Sensor (OQS) and Associated Parts	1-20
1.11	ATO (Auto Top Off) Components	1-20
1.11.1	JIB Cradle, JIB Cap and Pick-Up Assembly and JIB (ATO) Reset Switch	1-21
1.11.2	ATO Pump Assembly – Non-Bulk.....	1-21
1.11.3	ATO Pump Assembly – Bulk.....	1-22
1.12	Bulk System Components.....	1-23
1.12.1	Bulk Dispose Waste Valve	1-23
1.12.2	Bulk Manifold and Accessories	1-24
1.13	Datalink System Components	1-25
1.14	Basketlift Assy and Associated Parts.....	1-27
1.15	Simplified FilterQuick™ FQGLA30-T Series Simplified Wiring	1-29

FQGLA30-T FILTERQUICK™ GAS FRYERS

CHAPTER 1: PARTS LIST

1.1 Accessories

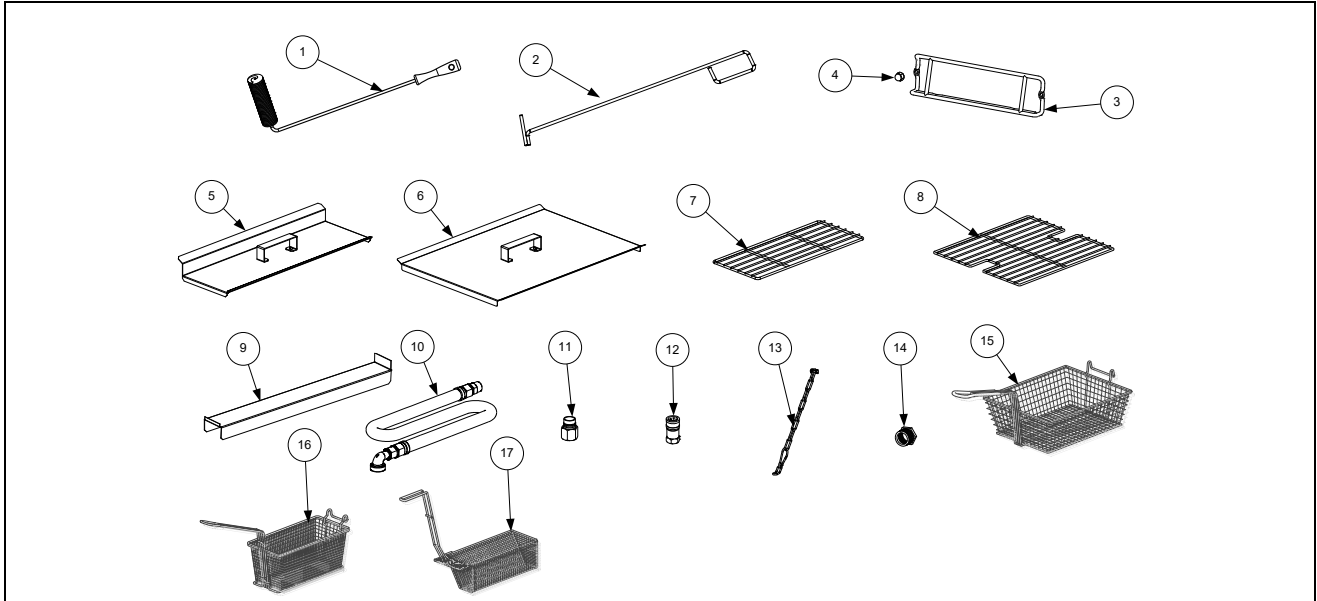

ITEM	PART #	COMPONENT
1	8030429	Brush, Frypot
2	8030388	Fryers Friend Low Oil Volume Frypot
3	8102793	Hanger, Basket
	8104623	Hanger, Basket 2-Battery
	8104622	Hanger, Basket 3-Battery
4	8090047	Nut, Cap 1/4-20 Hi Profile SS
5	1086267	Cover, Frypot, Dual Vat
6	1086266	Cover, Frypot, Full Vat
*	8260993SP	Handle Kit, Frypot Cover (includes handle and screws)
7	8030372	Basket Support Rack, Dual Vat
8	8030375	Basket Support Rack, Full Vat
*	8030136	Basket Support Screen, Full Vat (screen w/handle used in place of Item 8)
9	1086126	Connecting Strip, Frypot
10	8100478	Gas Line, 1-Inch Dormont Flexible
	8061698SP	36-Inch (for gas line only (w/o Items 11 and 12), use 8100088)
	8061699	48-Inch (for gas line only (w/o Items 11 and 12), use 8100085)
11	8100074	Quick-Disconnect Fitting, 1-Inch Male
12	8100073	Quick-Disconnect Fitting, 1-Inch Female
	8103745	Quick Disconnect Fittings, 3/4-inch set (includes male and female connectors)
13	8260900	Kit, Chain Restraint
*	8261095	Kit, Anchor Strap
*	8263283	Bracket, Locking Cabinet (used to lock into hoods)
14	8261045	Bushing, Flexible Gas Line (8130032)
15	8030099	Basket, Full Size
16	8030271	Basket, Twin Size
17	8030511	Tray, Sediment GL30 Taco Bell (use 8030382 for non-Taco Bell)

* Not illustrated.

1.2 Doors, Sides, Flue Caps, Top Caps, Flue Deflector and Casters

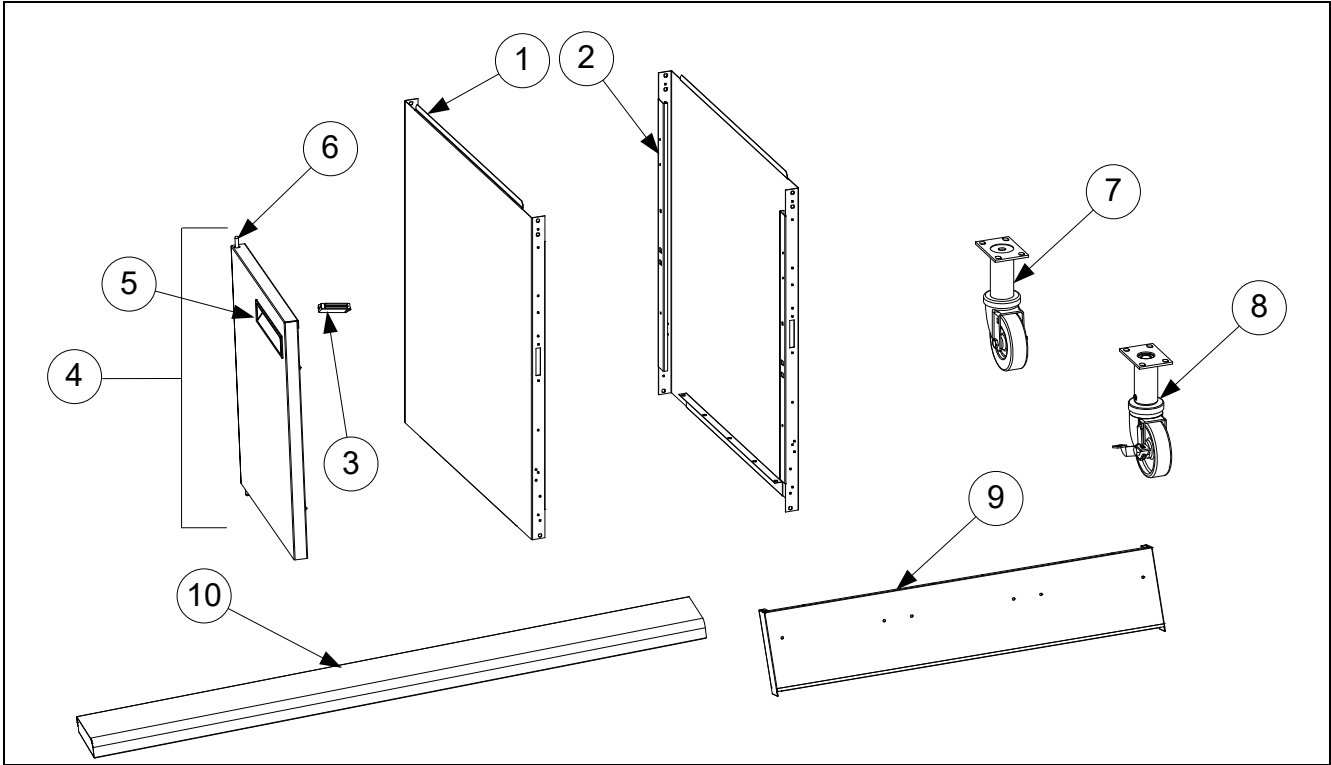

ITEM	PART #	COMPONENT
1	2610759	Side, Cabinet Left
2	2620759	Side, Cabinet Right
3	8101105	Magnet, Door
4	1086040	Door, Right (shown)
*	1086039	Door, Left
5	8104146	Handle, Snap-In-Plastic
6	1064067	Pin Assembly, Door
*	8100275	Spring, Door Pin
*	8100658	Retaining Ring
*	2307192	Hinge, Door Lower
*	2206097	Holder, Manual
7	8100327	Caster without Brake
8	8100944	Caster with Brake
9		Flue Cap-Stainless Steel
	8238852	Two Station Fryer (requires 2-8238858, 4-8091105 and 4-8160950)
	8238847	Three Station Fryer (requires 3-8238858, 6-8091105 and 6-8160950)
	8239361	Four Station Fryer (requires 4-8238858, 8-8091105 and 8-8160950)
	8239362	Five Station Fryer (requires 5-8238858, 10-8091105 and 10-8160950)
	8238858	Plate W/A, Basket Hanger w/ studs (used to mount basket hanger - one required per frypot)
	8091105	Pushnut, 1/4" Retainer
	8160950	O-Ring, .139 x .250 Viton (used as a spacer between plate and flue cap)
10		Top Cap (Cap for 5-station fryer shown)
	1086075	Two Station Fryer
	1086043	Three Station Fryer
	1086088	Four Station Fryer
	1086089	Five Station Fryer

* Not illustrated.

1.3 Drain System Components

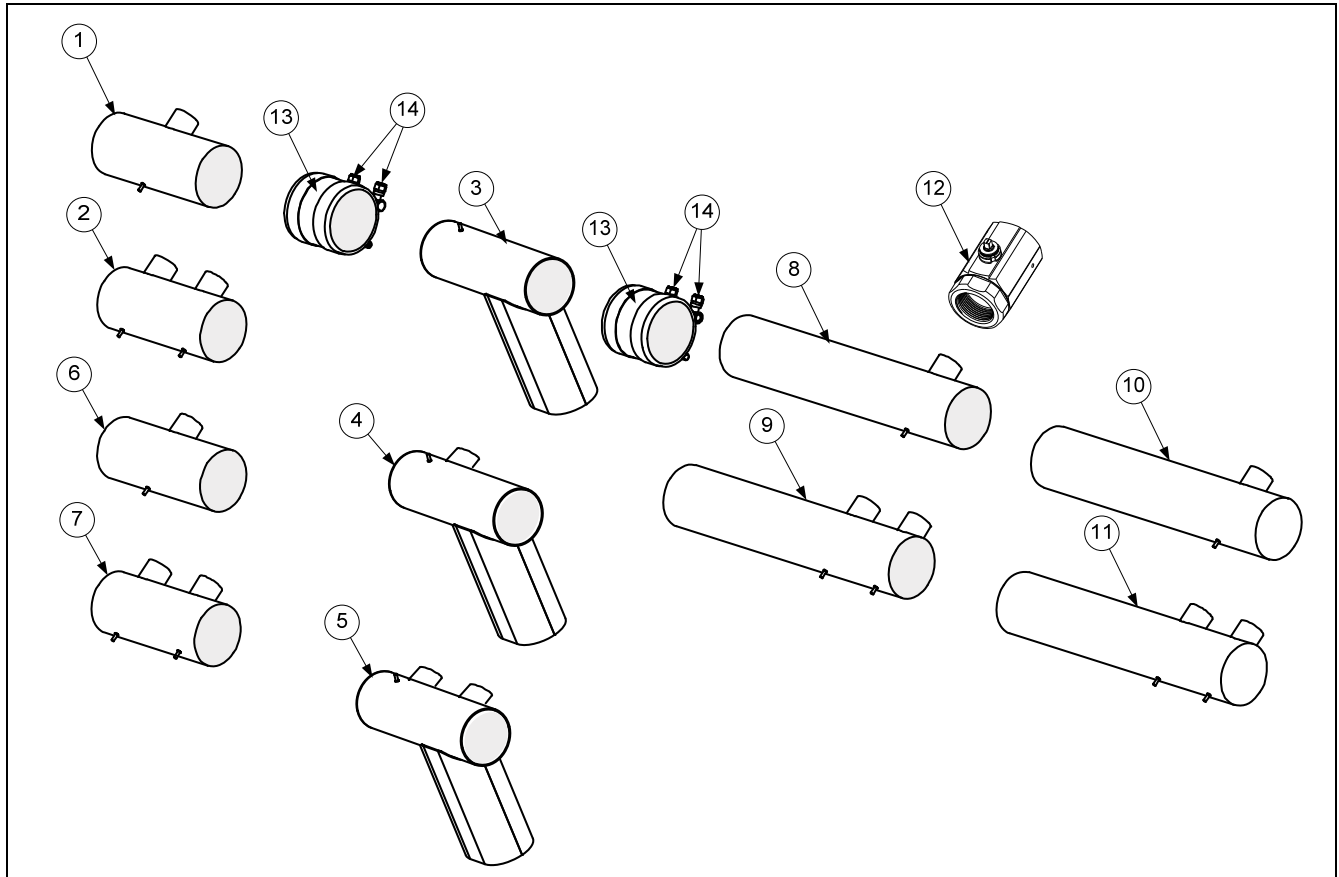

ITEM	PART #	COMPONENT
1	8239132	Drain Tube, Full-Vat Left Closed/Right End Open or Left Open/Right End Closed (Short)
2	8239134	Drain Tube, Dual-Vat Left Closed/Right End Open or Left Open/Right End Closed (Short)
3	8238799	Drain Tube, Downspout (3+ Battery)
4	8239131	Drain Tube, Downspout Full-Vat (2 Battery)
5	8239133	Drain Tube, Downspout Dual-Vat (2 Battery)
6	8239137	Drain Tube, Full-Vat Left and Right Open (Short)
7	8239138	Drain Tube, Dual-Vat Left and Right Open (Short)
8	8239139	Drain Tube, Full-Vat Left and Right Open (Long)
9	8239140	Drain Tube, Dual-Vat Left and Right Open (Long)
10	8239135	Drain Tube, Full-Vat Left Open/Right End Closed (Long)
11	8239136	Drain Tube, Dual-Vat Left Open/Right End Closed (Long)
12	8104353	Valve, 1¼-inch NPT Rotary Actuator
13	8160772	Sleeve
14	8091095	Clamp 3.25" x 3.00" Double T-Bolt
	8090969	Clamp 3.25" x .75" Single T-Bolt
*	8160665	Vinyl Cap .218 x 500

* Not illustrated.

1.4 Electronics and Electrical Components
 1.4.1 Component Boxes and Associated Components

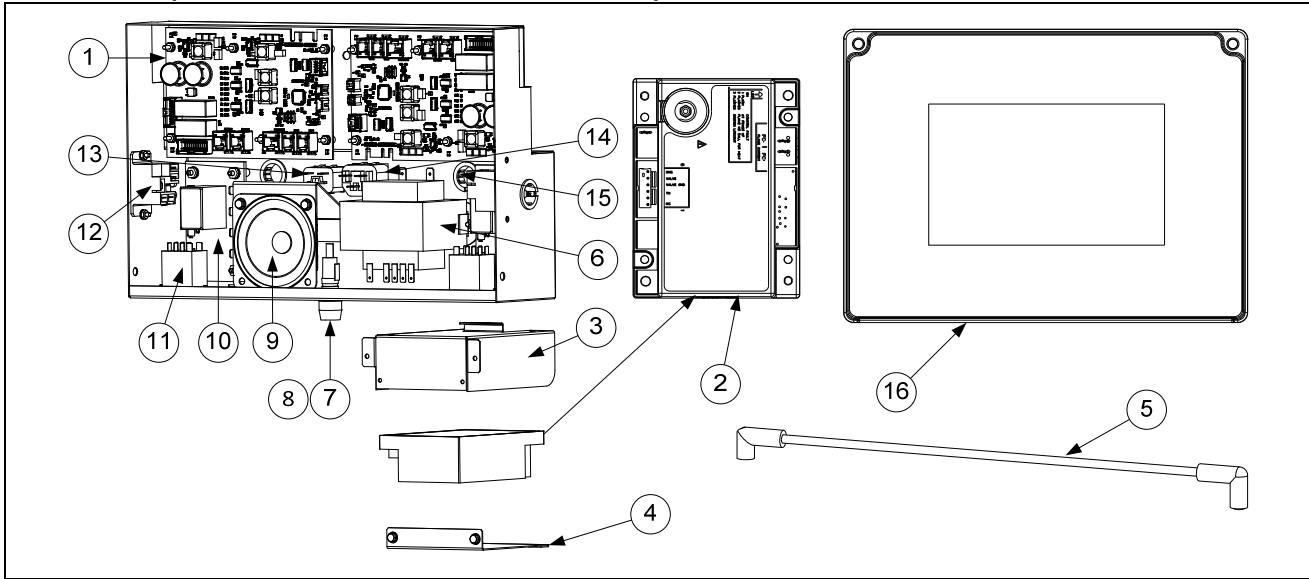

ITEM	PART #	COMPONENT
√ 1	1087511	Board, Interface SIB (Smart Interface Board) General Market/ Burger King
√	1087533	Board, Interface SIB (Smart Interface Board) Taco Bell
√ *	8076162	Harness, Ignition Module Fenwal DV
√ *	8076163	Harness, Ignition Module Fenwal FV
√ 2	8075949	Module, Ignition Single Spark Fenwal
3	1087468	Bracket, Ignition Module Fenwal
4	2401585	Cover, Ignition Module Fenwal
√ 5	8075614	Cable, 12-inch Ignition
*	8073484	Connector, Rajah
√ 6	8075362	Transformer, 24VAC 80VA 100V-240V
√ 7	8071321	Fuse Holder
√ 8	8075570	Fuse 3.5A 250V
√ 9	8075829	Speaker 4ohm
10	8074812	Relay, 7-sec. Time Delay 120V (<i>U.S., Canadian & Mexico units</i>) (only units w/ OIB sensor)
	8074934	Relay, 7-sec. Time Delay 220V, 230V, 240V & 250V (<i>International units</i>) (only units w/ OIB sensor)
11	8075623	Relay, 24VDC SPDT OIB (Oil Is Back) Sensor (only on units with OIB sensor)
√ 12	8071683	Relay, Blower 12VDC
13	8075368	Receptacle, C14 IEC Cord Inlet
14	8075369	Receptacle, C14 IEC Cord Outlet
15	8071926	Bushing, .875 Split
√ 16	1087515SP	Controller, FQ4000 General Market/Burger King
√	1087847SP	Controller, FQ4000 Taco Bell
*	8104320	Lanyard, Controller Restraint
		See Wiring Diagrams in FQGLA30-T Service Manual for cable locations
*	8075553	Cable, P-Bus Left SIB to Right SIB
*	8075555	Cable, P-Bus w/ power Right SIB to VIB (Valve Interface Board)
*	8075551	Cable, C-Bus Right SIB to FIB (Filtration Interface Board)
*	8075549	Cable, C-Bus Right SIB to Right SIB (Connects component boxes together)
*	8075554	Cable, C-Bus w/ power 85" (Connects SIB to FIB)
*	8075632	Terminator, CAN End Communication RJ11
*	8075863	Harness, Wire Right SIB J1 to Components
*	8075864	Harness, Wire Left SIB J1 to Components

* Not illustrated. √ Recommended parts.

1.4.1 Component Boxes and Associated Components cont.

ITEM	PART #	COMPONENT
*	8075380	Harness, Wire SIB J2 to Components Full Vat
*	8075379	Harness, Wire SIB J2 to Components Dual Vat
*	1086017	Harness Assy, Power Blower
*	8075564	Cord, Power Distribution Box to Left Component Box
*	8075568	Cord, Power Component Box to Component Box
*	8076106	Adapter, RJ11 CAN to Legacy 6-pin CAN (Micro Mate & Lock) (connects OQS sensor to SIB bd) 5"

* Not illustrated. √ Recommended parts.

1.4.2 Power Distribution Boxes

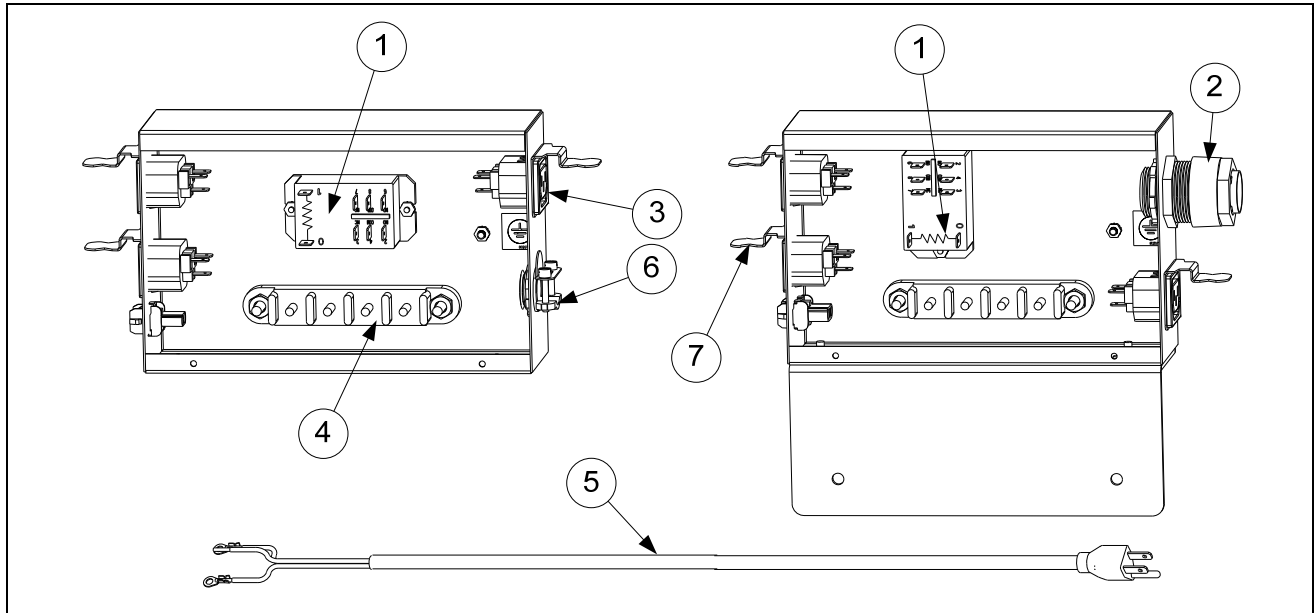

ITEM	PART #	COMPONENT
		Box Assembly, Power Distribution
√ 1	8075802	Relay, 30A DPDT 120VAC Coil (Master Power Reset)
2	8071560	Strain Relief
√ 3	8075369	Receptacle, C14 IEC Cord Outlet
4	8071973	Terminal, Post
5	8067742	Cord set with ring terminals 68" (used on units without hood relay)
6	8071612	Clamp, 3/8 Connector
7	2401312	Bracket, Power Out Cord Tie Down
		See Wiring Diagram 8052002 in FQGLA30-T Service Manual for cable locations
*	8075564	Cord, Power Distribution Box to Left Component Box
*	8075565	Cord, Power Distribution Box to FIB Box

* Not illustrated.
√ Recommended parts.

1.4.3 ATO (Automatic Top Off)/FIB (Filter Interface Board) /Filter Box Components

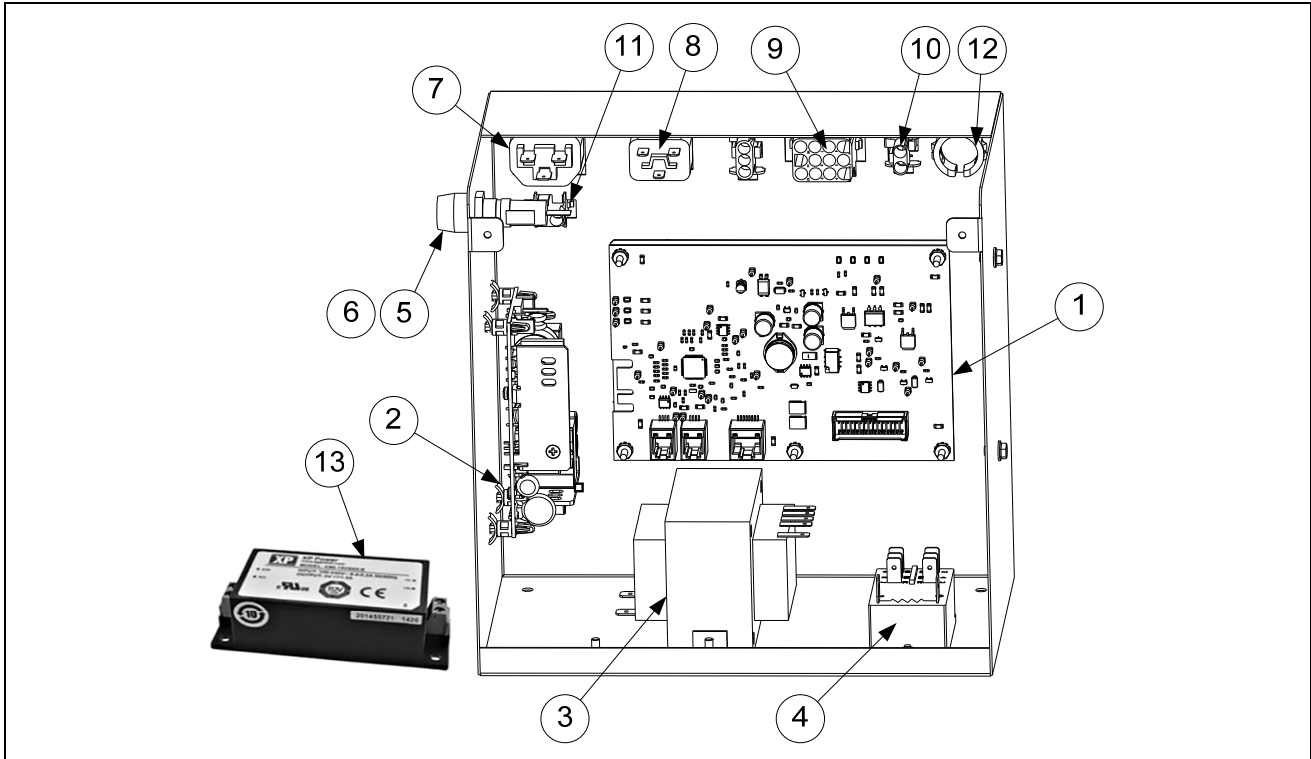

ITEM	PART #	COMPONENT
	1085993	Box Assembly, ATO/FIB Filter
√ 1	1087513	Board, FIB w/ Software General Market/ Burger King
	1087535	Board, FIB w/ Software Taco Bell
√ 2	8263684	Power Supply, 24VDC 130W ATO Actuators, Filter Pump, Top Off Pump
√ 3	8075362	Transformer, 24VAC 80VA 100V-240V
√ 4	8074482	Relay, Filter Pump DPDT 24VDC
√ 5	8075570	Fuse, 250VAC 3.5A Fast Acting
6	8071321	Holder, Fuse
7	8075369	Receptacle, C14 IEC Cord Outlet
*	2401312	Bracket, Power Out Cord Tie Down
8	8075368	Receptacle, C14 IEC Cord Inlet
*	2401311	Bracket, Power In Cord Tie Down
9	8075803	Harness, Bulk Oil/Top off FIB
10	1086005	Wire Assembly, Solid Shortening Heater Switch
11	8075804	Harness, FIB Power Supply/Heat tapes
12	8071926	Bushing, .875 Split
13	8075974	Power Supply, 24VDC, 15W for KCCM SUI board
*	8076106	Adapter, RJ11 CAN to Legacy 6-pin CAN (Micro Mate & Lock)(connects OQS sensor/SIB bd 5")
*	2401088	Cover, ATO/Filter Box
		See Wiring Diagram 8052002 in FQGLA30-T Service Manual for cable locations
*	8075565	Cord, Power Distribution Box to FIB Box, Filter Pump
*	8075632	Terminator, CAN End Communication RJ11
*	8075551	Cable, C-Bus Right SIB to FIB (Filtration Interface Board)
*	8075554	Cable, C-Bus w/ power 85" (Connects SIB to FIB)
*	8075810	Cable, FIB to VIB Actuator Power

* Not illustrated.

√ Recommended parts.

1.4.4 VIB (Valve Interface Board) Components

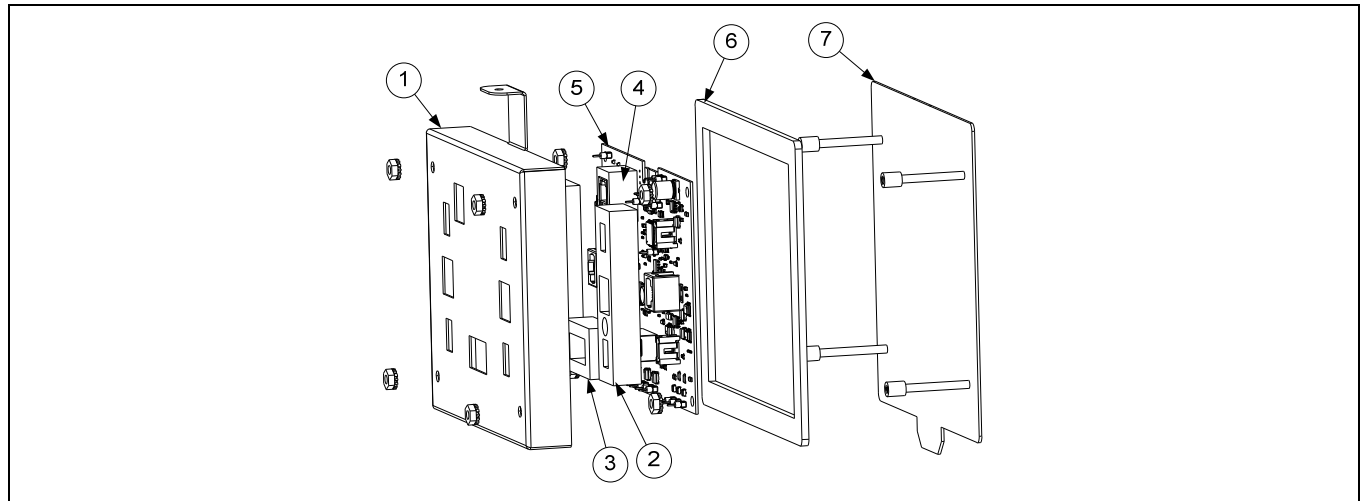

ITEM	PART #	COMPONENT
√	1087514	VIB Board Assembly
1	8242346	Cover, VIB Board Housing
2	8161015	Gasket, Actuator Power VIB
3	8161013	Gasket, 20 pin VIB Connector
4	8161014	Gasket, P-Bus VIB Connector
5	1087534SP	Board, VIB with SW
6	8160820	Seal, Linear Actuator Board
7	1087280	Panel, Assy VIB Box Bottom Stud

√ Recommended parts.

1.4.5 Power Reset Switch and USB Connector

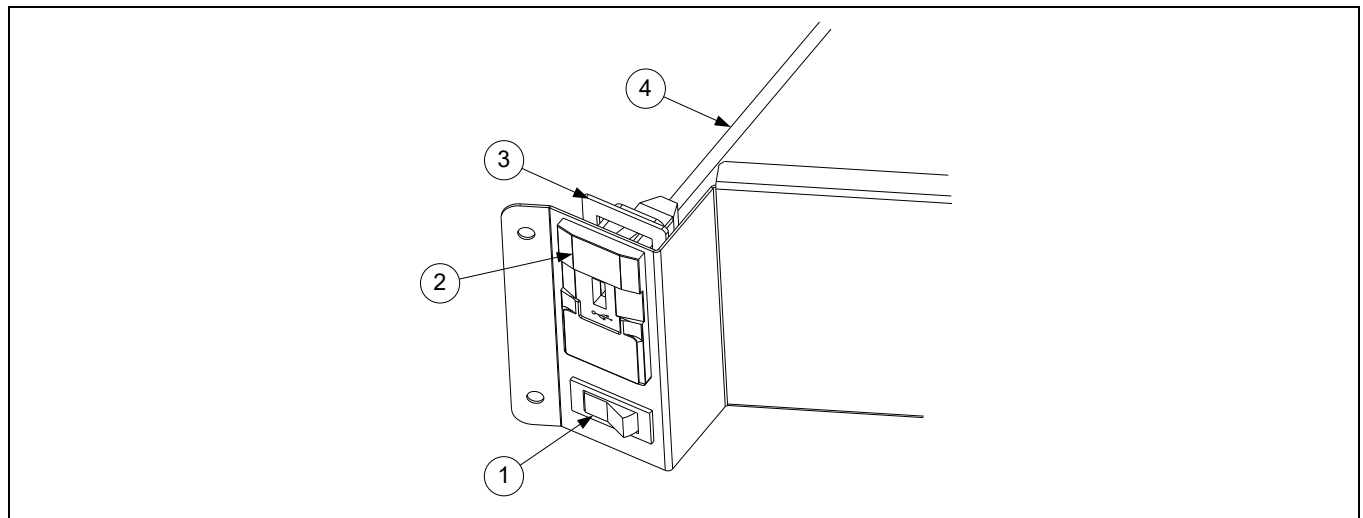

ITEM	PART #	COMPONENT
	1085728	Bracket Assy, USB Mounting Gas
1	8072659	Switch
2	8074989	Bezel, USB Port
3	2207520	Plate, Backing USB Bezel
4	8074990	Cable, USB

1.5 Wiring

1.5.1 Main Wiring Harnesses SIB J1 to Components

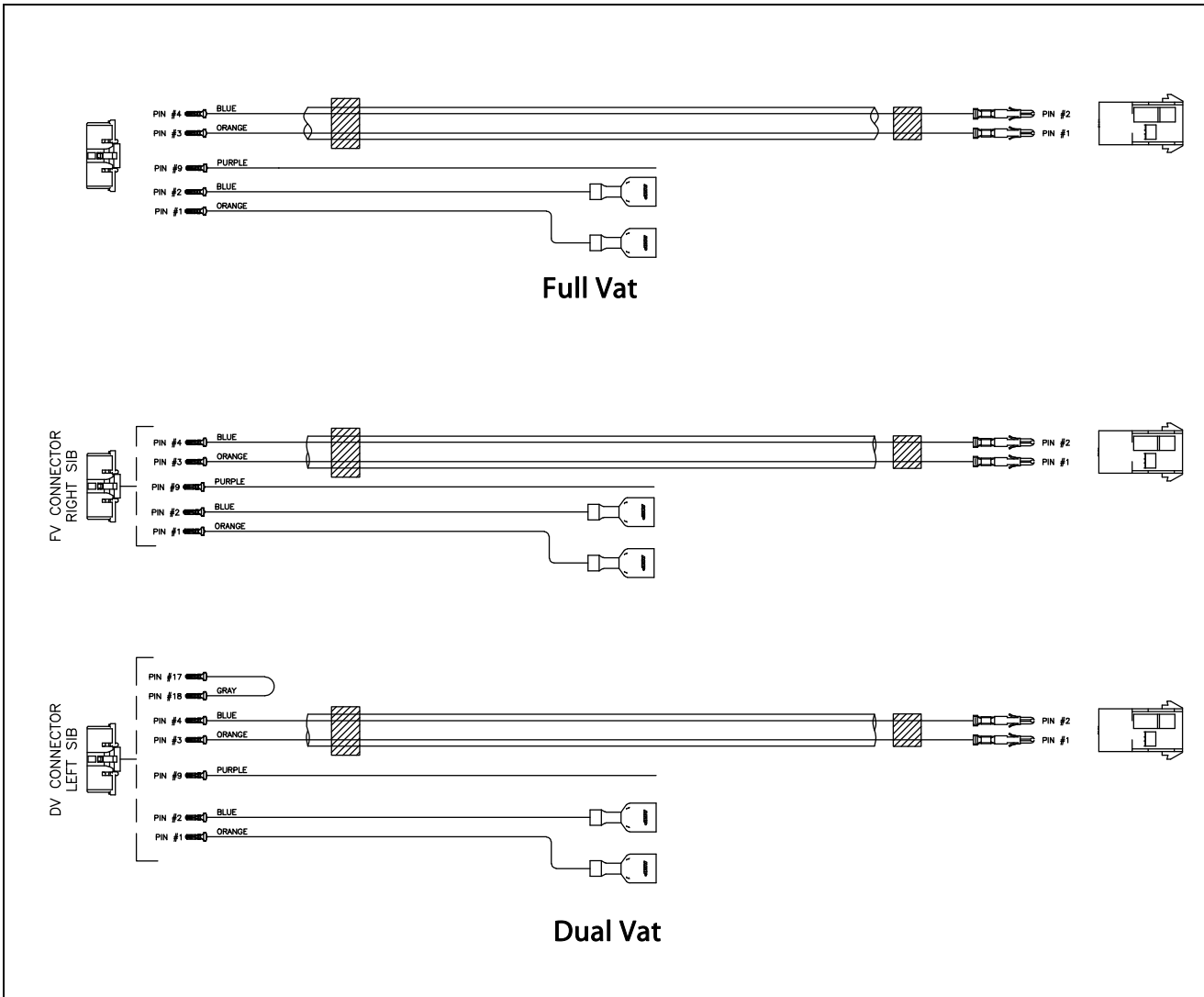

ITEM	PART #	COMPONENT
	8075863	Harness, Modular Wiring Gas Full Vat
	8075864	Harness, Modular Wiring Gas Dual Vat

See 8052048 and 8052049 in the FQGLA30-T Service Manual for wiring diagrams.

1.5.2 Ignition Wiring Harnesses SIB J2 to Components

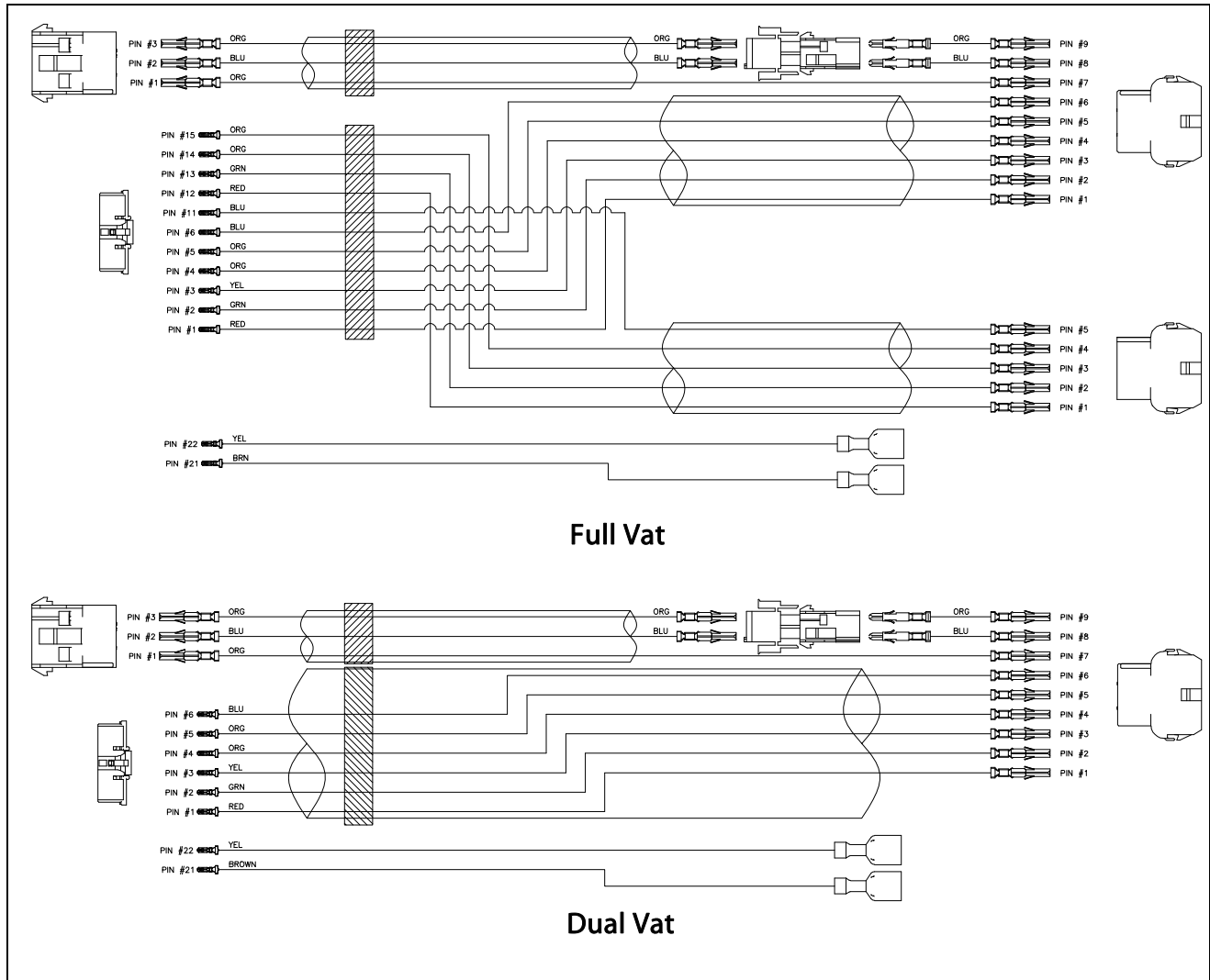

ITEM	PART #	COMPONENT
	8075380	Harness, Ignition Wiring Gas Full Vat
	8075379	Harness, Ignition Wiring Gas Dual Vat (one per side of dual vat)

See 8052048 and 8052049 in the FQGLA30-T Service Manual for wiring diagrams.

1.6 Frypots and Associated Components

1.6.1 Full-Vat Frypot Components

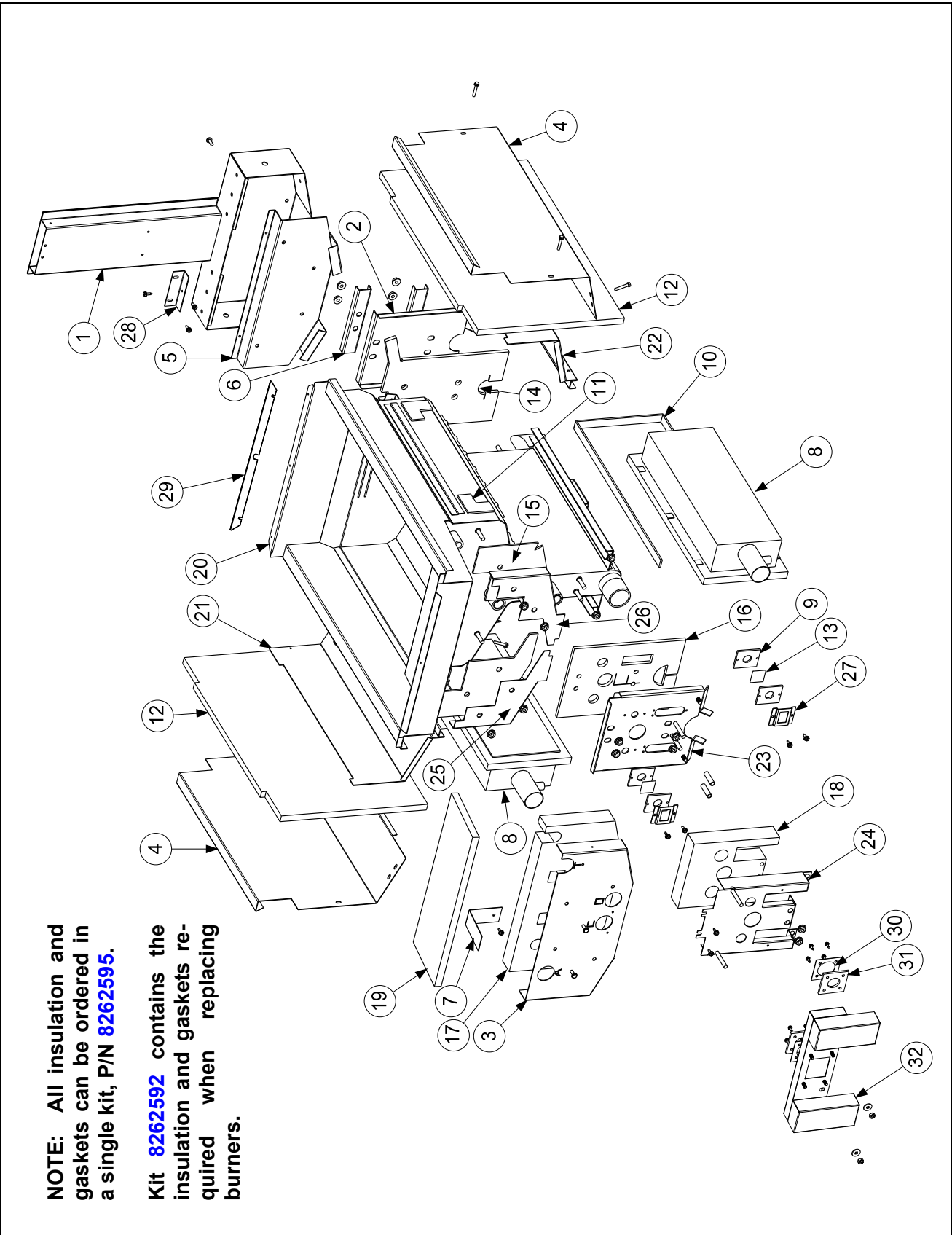

1.6.1 Full-Vat Frypot Components cont.

ITEM	PART #	COMPONENT
	1085642SP	Frypot Assembly Full-Vat M5G30U (NAT/PRO)
	8262595	Insulation Kit, Complete Full-Vat
	8262592	Insulation Kit, Burner Full-Vat
1	1085646	Flue Assembly, Full-Vat
2	8238175	Back, Lower Full-Vat Combustion Chamber
3	2206529	Cover, Full-Vat Upper Insulation
4	2209665	Cover, Outer Blanket
5	2309309	Plate, FV Collector Mounting
6	2202851	Brace, FV Rear Insulation
7	2202920	Brace, Foam Deck Insulation
√ 8	8103435	Burner, Universal Replacement Low Oil Volume
9	8120356	Insulation, Burner Sight Glass
10	8160900	Insulation, Burner
11	8120706	Insulation, Upper Burner Rail
12	8121029	Insulation, Combustion Chamber Side
13	8140048SP	Glass, Burner Sight
14	8160837	Insulation, FV Rear Lower
15	8160731	Insulation, FV LH/RH Front Seal
16	8160976	Insulation, FV Lower Inner Front
17	8160733	Insulation, FV Front Upper
18	8160978	Insulation, FV Outer Front
19	8160746	Insulation, Foam Deck
20	8238751	Frypot, FV M5G30U
21	8238193	Retainer, FV LH Upper Burner
22	8238194	Retainer, FV RH Upper Burner
23	8238577	Cover, FV Front Combustion
24	8238602	Cover, FV Lower Front Insulation
25	8242164	Front Upper Seal Weldment, FV LH
26	8242165	Front Upper Seal Weldment, FV RH
27	9001031	Retainer, Burner Sight Glass
28	9300818	Bracket, Flue to Pot
29	2209667	Strip, Pot/Fluecap
30	9001049	Retainer, Plenum Gasket
31	8160057	Gasket, Plenum
32	8238642	Plenum, Full-Vat Domestic
	1084762	Plenum, Full-Vat Export (Non-CE, Non-Japan)
	1086671	Plenum, Full-Vat Export (Japan, CE)
*	8161049	Gasket, Plenum/Blower (used between plenum and blower)
*	8160981	Gasket, Ignitor Solaronics
*	9102474	Pot-to-Pot Gap Clip

* Not illustrated.

√ Recommended parts.

1.6.2 Dual-Vat Frypot Components

NOTE: All insulation and gaskets can be ordered in a single kit, P/N [8262596](#).

Kit [8262593](#) contains the insulation and gaskets required when replacing burners.

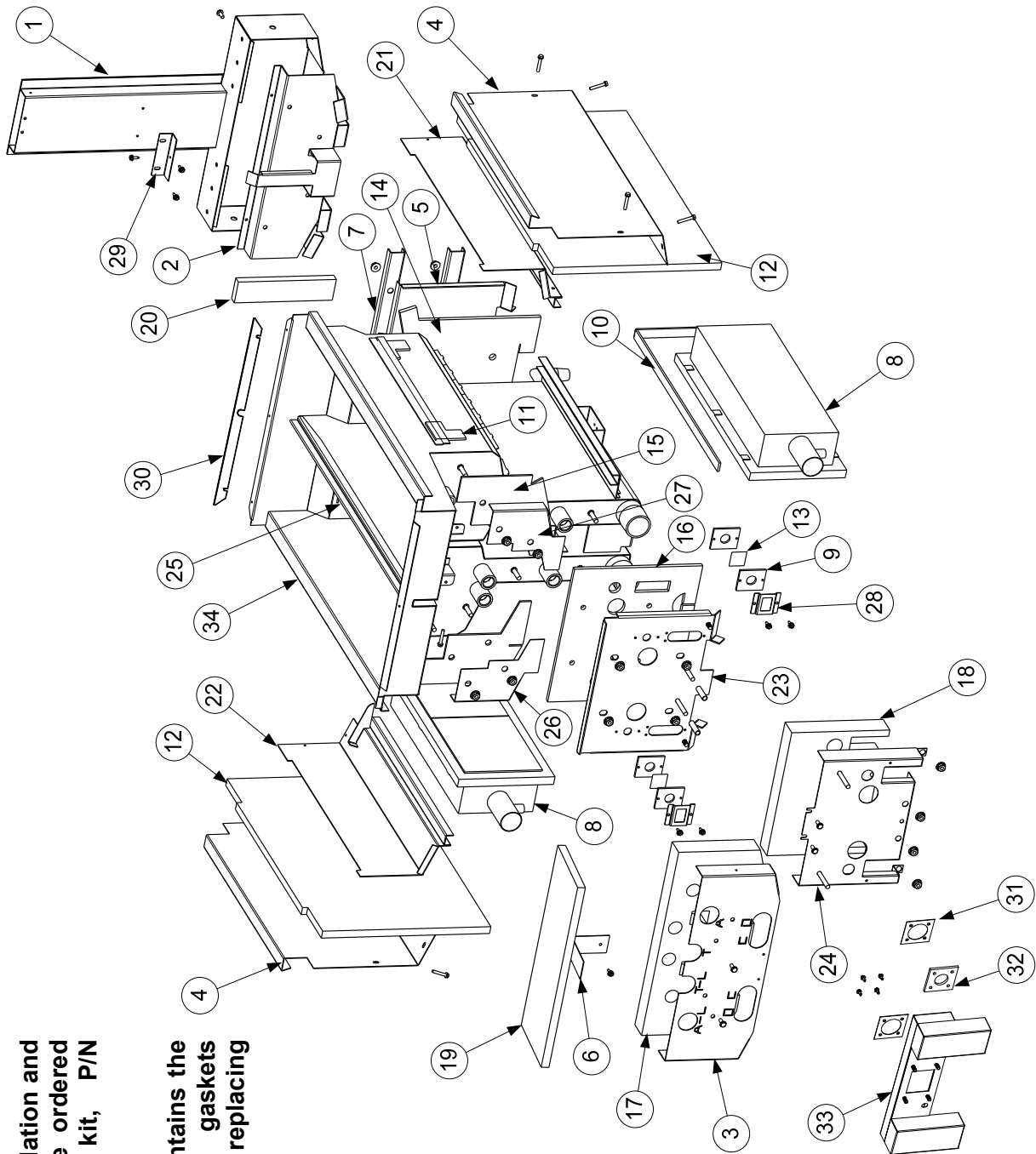

1.6.2 Dual-Vat Frypot Components cont.

ITEM	PART #	COMPONENT
*	1085643SP	Frypot Assembly Dual-Vat M5G30UD (NAT/PRO)
*	8262596	Insulation Kit, Complete Dual-Vat
*	8262593	Insulation Kit, Burner Dual-Vat
1	1085647	Flue Assembly, Dual-Vat
2	1083907	Plate Assembly, Dual-Vat Collector
3	2206530	Cover, Dual-Vat Upper Insulation
4	2209714	Cover, Dual-Vat Outer Blanket
5	8238176	Back, Dual-Vat Lower Combustion Chamber
6	2202920	Brace, Foam Deck Insulation
7	2202972	Brace, Dual-Vat Rear Insulation
√ 8	8103435	Burner, Universal Replacement
9	8120356	Insulation, Burner Sight Glass
10	8160900	Insulation, Burner
11	8120706	Insulation, Upper Burner Rail
12	8121029	Insulation, Combustion Chamber Side
13	8140048SP	Glass, Burner Sight
14	8160838	Insulation, Dual-Vat Rear Lower
15	8160741	Insulation, Dual-Vat LH/RH Front Seal
16	8160977	Insulation, Dual-Vat Lower Inner Front
17	8160743	Insulation, Dual-Vat Front Upper
18	8160979	Insulation, Dual-Vat Outer Front
19	8160746	Insulation, Foam Deck
20	8120688	Insulation, Flue Collection
21	8238196	Retainer, Dual-Vat RH Upper Burner
22	8238195	Retainer, Dual-Vat LH Upper Burner
23	8238578	Cover, Dual-Vat Front Combustion
24	8238605	Cover, Dual-Vat Lower Insulation
25	8242352	Riser W/A Dual-Vat Frypot
26	8242166	Dual-Vat LH Upper W/A Seal
27	8242167	Dual-Vat RH Upper W/A Seal
28	9001031	Retainer, Sight Glass
29	9300818	Bracket, Flue to Pot
30	2209667	Strip, Pot/Fluecap
31	9001049	Retainer, Plenum Gasket
32	8160057	Gasket, Plenum
*	8160981	Gasket, Ignitor Solaronics
33	8238643	Plenum, Dual-Vat Domestic
	1084763	Plenum, Dual-Vat Export (Non-CE, Non-Japan)
	1086672	Plenum, Dual-Vat Export (Japan, CE)
*	8161049	Gasket, Plenum/Blower (used between plenum and blower)
34	8238752	Frypot, Dual-Vat M5G30UD
*	9102474	Pot-to-Pot Gap Clip

* Not illustrated.

√ Recommended parts.

1.6.3 Frypot Assemblies and Associated Parts

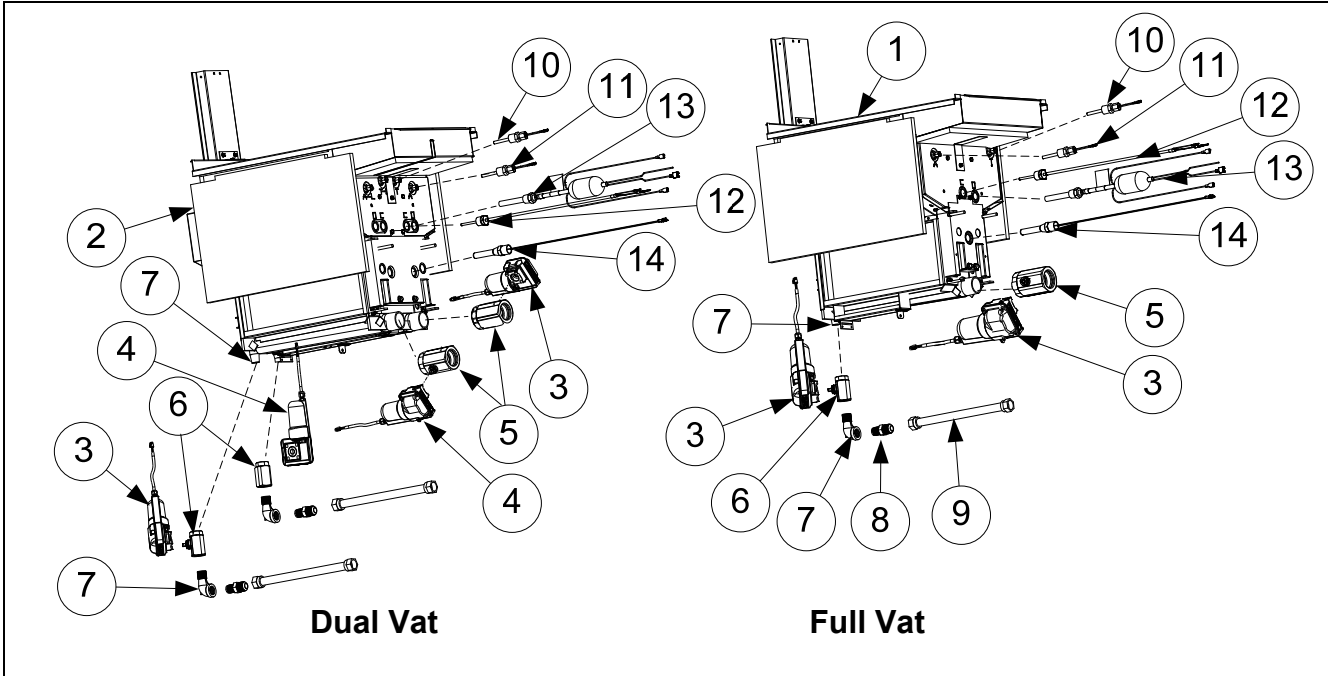

ITEM	PART #	COMPONENT
1	1085642SP	Frypot Assembly, Full-Vat M5G30U Natural/Propane
2	1085643SP	Frypot Assembly, Dual-Vat M5G30UD Natural/Propane
√ 3	8075809	Actuator, Rotary 24VDC BLUE LH
√ 4	8075808	Actuator, Rotary 24VDC BLACK RH
√ 5	8104353	Valve, 1¼" NPT Drain Rotary Actuator M5G30U
√ 6	8103754	Valve, ½" NPT Return Rotary Actuator
7	8130908	Adaptor, ½" NPT M/F 90°
8	8101668	Adaptor, Male ⅝" OD x ½"
9	8101055	Flexline, ⅝" OD x 11.50" Long
√ 10	8263286	Probe, ATO (Topoff) RTD Kit
11	8263287	Probe, VIB (Auto Filtration) RTD Kit (only units with VIB probes)
*	8130617	Fitting, 3/16" CC x ¼" (Compression fitting used in probe kits)
*	8158000	Loctite 567, Tube 6 ML
√ 12	8263285	Probe, Temperature Cooking Kit
13	1085578	Sensor Assy, Oil 100V (only units with OIB sensors)
	8122302	Sensor Assy, Oil 120V (only units with OIB sensors)
	8074947	Sensor Assy, Oil 220V <i>International</i> (only units with OIB sensors)
	8074935	Sensor Assy, Oil 230V <i>International</i> (only units with OIB sensors)
	8074942	Sensor Assy, Oil 240V and 250V <i>International</i> (only units with OIB sensors)
√ 14	8261177	Thermostat Assembly, HE FM High-Limit 425°F/218°C Kit

√ Recommended parts.

1.7 Oil Return Manifolds

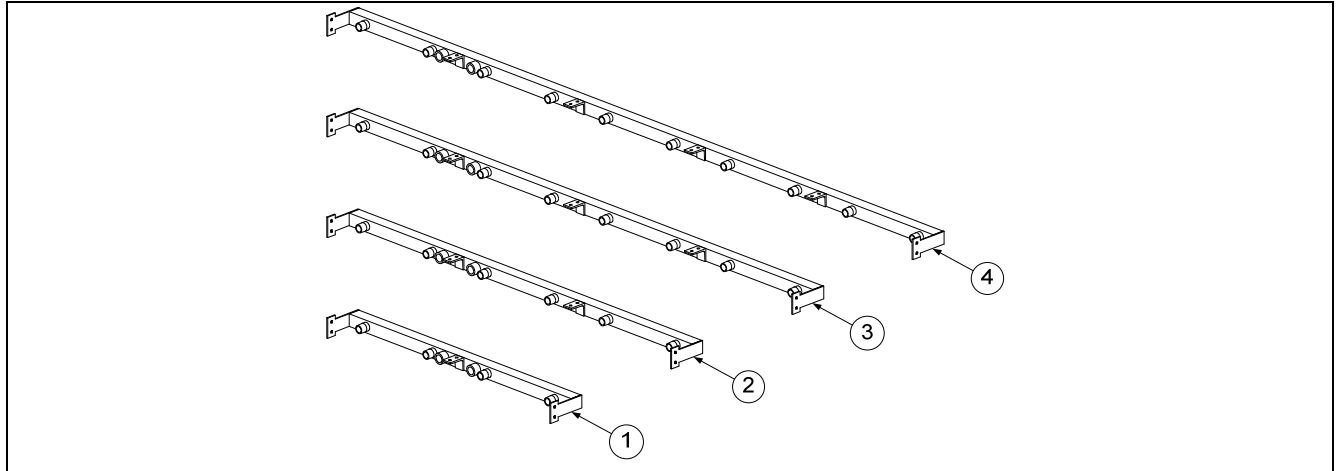

ITEM	PART #	COMPONENT
1	8104414	Manifold, Two-Station Fryer Full Vat
	8104413	Manifold, Two-Station Fryer Dual or Mixed Vats
2	8104378	Manifold, Three-Station Fryer Full Vat
	8104392	Manifold, Three-Station Fryer Dual or Mixed Vats
3	8104418	Manifold, Four-Station Fryer Full Vat
	8104417	Manifold, Four-Station Fryer Dual or Mixed Vats
4	8104419	Manifold, Five-Station Fryer Full, Dual or Mixed Vats
*	8130907	Cap, 15/16-inch Valve

* Not illustrated

1.8 Gas Supply and Combustion System Components

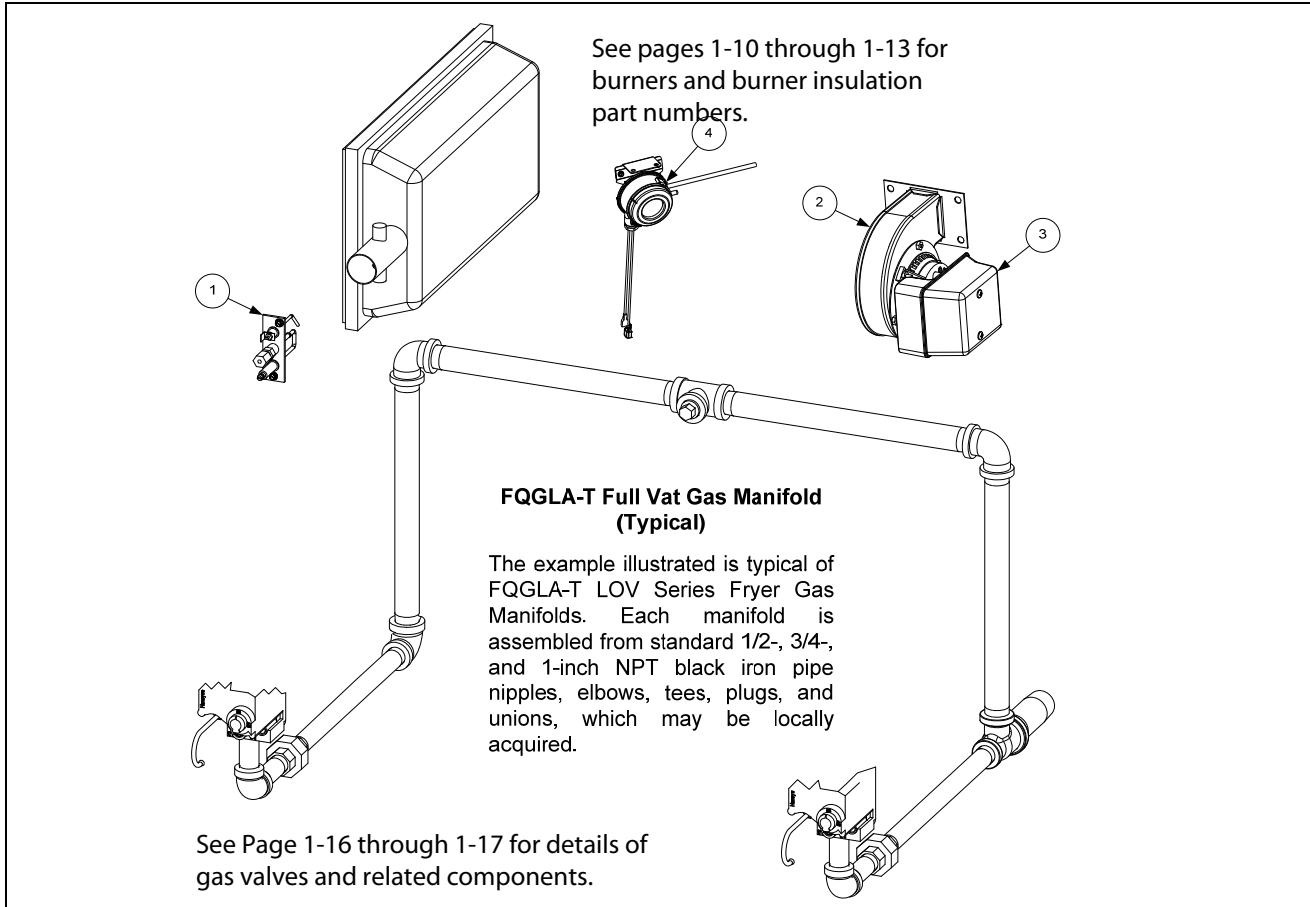

ITEM	PART #	COMPONENT
√ 1		Ignitor
	8263053	Natural Gas (G20, G25) (includes gasket 8160981, which may be ordered separately and enrichment tubes)
	8263054	Natural Gas (G20, G25) (includes gasket 8160981, which may be ordered separately)
	8263189	Propane (G30, G31) (includes gasket 8160981, which may be ordered separately and enrichment tubes)
	8262994	Propane (G30, G31) (includes gasket 8160981, which may be ordered separately)
√ 2		Blower Assembly, Combustion Air (includes harness and Item 3)
	1086012SP	100V 50/60 Hz CE (Right) CE (Wide Body) Dual Vat – 7 slots open
	1085699SP	100V 50/60 Hz CE (Right) CE (Wide Body) Full Vat – 8 slots open
	1062999SP	100V 50/60 Hz CE (Right) 60Hz Specific
	1081957SP	115V-120V 50/60 Hz (Right)
	1087155SP	220V 60 Hz (Right)
	1062998SP	208-240V 50/60 Hz (Right) Non-CE International
	1063001SP	230V 50/60 Hz CE (Right) CE (Wide Body)
*	8161049	Gasket, Plenum/Blower (used between plenum and blower)
3	8160554	Cover, Blower Motor (component of all blowers listed above)
*	1086122	Harness Assembly, Blower Motor DV (component of blowers listed above)
	1086017	Harness Assembly, Blower Motor FV/DV (component of blowers listed above)
4	1086657	Switch, Air Pressure Assembly FV (8072262 switch alone) CE and Export
	1086658	Switch, Air Pressure Assembly DV (8072262 switch alone) CE and Export

* Not illustrated.

√ Recommended parts.

1.9 Gas Valves and Associated Components

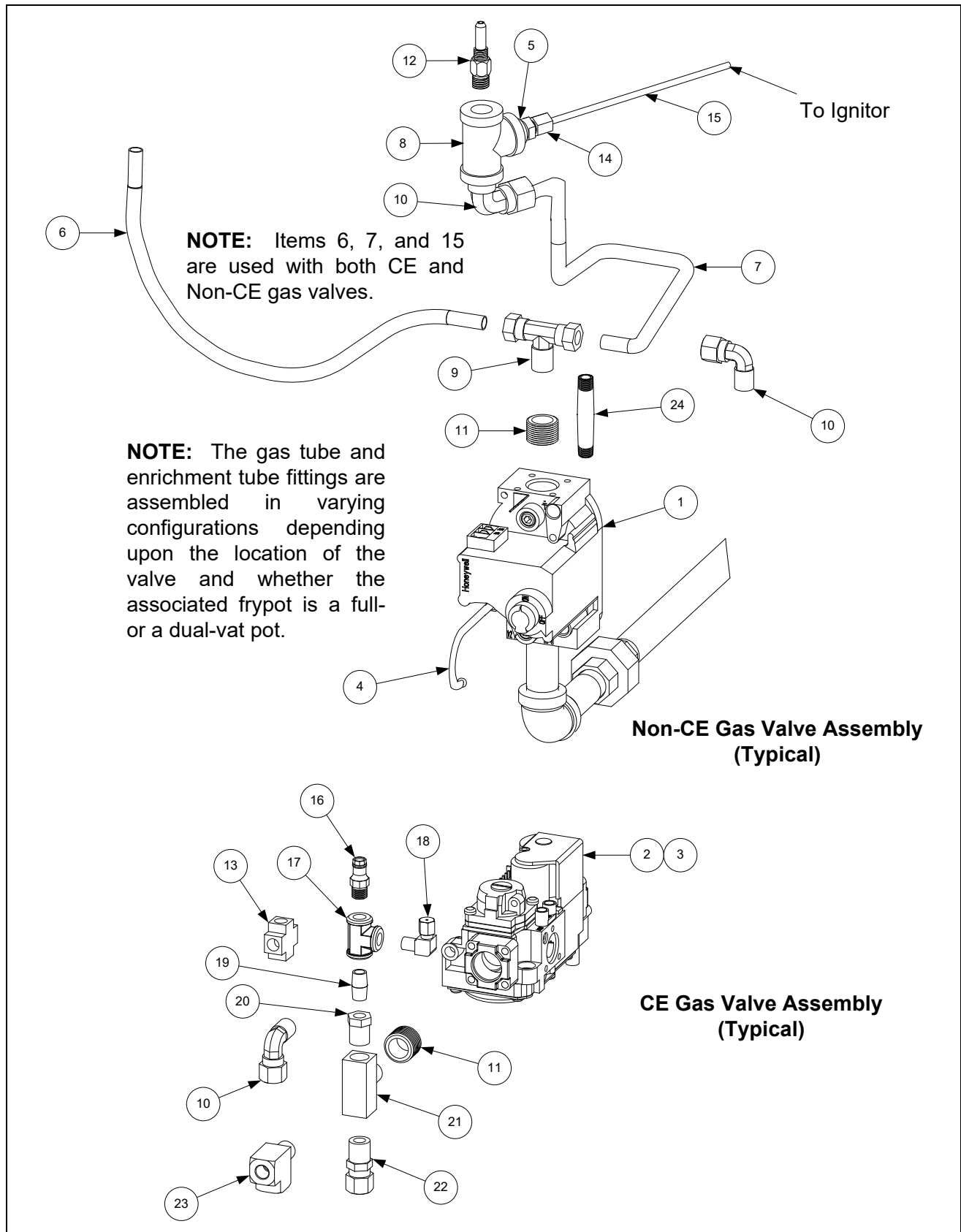

1.9 Gas Valves and Associated Components cont.

ITEM	PART #	COMPONENT
		Gas Conversion Kits
	8262969	<i>Natural to Propane (LP) Full Vat</i>
	8262970	<i>Natural to Propane (LP) Dual Vat</i>
	8262971	<i>Propane(LP) to Natural Full Vat</i>
	8262972	<i>Propane(LP) to Natural Dual Vat</i>
√ 1		Valve, Non-CE Gas
	8104339	Natural Gas (G20, G25) 3.2WC
	8100802	Propane Gas (G30, G31)
	8263296	Kit Natural Gas Full Vat w/ flexlines and hardware
	8263297	Kit Natural Gas Dual Vat w/ flexlines and hardware
	8261123	Propane Gas (G30, G31)
	8263298	Kit, Propane Gas Full Vat w/ flexlines and hardware
	8263299	Kit, Propane Gas Dual Vat w/ flexlines and hardware
√ 2	8101715	Valve, CE Gas (G20, G25, G30, G31)
3	8101041	Accessory Kit (contains parts to adapt Item 2 to specific fryer configuration)
4	8100691	Tube, 1/8-inch Vent
5	8103147	Bushing, 3/4-inch OD x 1/2 -inch ID NPT Flush
6	8101355	Gas Line, 3/8-inch OD X 15-inch SS Flexible
7	8101354	Gas Line, 3/8-inch OD X 12-inch SS Flexible
	8101353	Gas Line, 3/8-inch OD X 9-inch SS Flexible (Used on some split pots)
8	8130449	Tee, 1/4 -inch NPT Brass
9	8130301	Tee, 1/4-inch Male NPT to 3/8-inch Tube
10	8130302	Elbow, 1/4-inch Male NPT to 3/8-inch Tube 90° (used on DV valve)
11	8130304	Bushing, 1/2-inch NPT to 1/4-inch NPT Flush Reducing
12		Orifice, Burner
	8103977	1.88mm 75% Butane/25% Butane (Standard Elevation)
	8103865	1.95mm Propane/Butane (G30, G31)
	8103860	2.05 mm Propane/Butane (G30, G31) (0-4999 Ft, 0-1524 M)
	8103863	2.10 mm Propane/Butane (G30, G31) (5000-6999 Ft, 1525-2133 M)
	8103867	2.84mm Natural Gas (G20, G25) Australia Only DV
	8103866	2.92mm Natural Gas (G20, G25) Australia Only FV
	8103864	3.18 mm Natural Gas (G20, G25) (0-4999 Ft, 0-1524 M) CE
	8103861	3.26 mm Natural Gas (G20, G25) (0-4999 Ft, 0-1524 M)
	8103862	3.40 mm Natural Gas (G20, G25) (5000-6999 Ft, 1525-2133 M)
13	8130378	Fitting, 1/8-inch NPT Cross
14	8130340	Adapter, 1/8-inch NPT to 1/8-inch Tube
15	8104238	Tube, 1/8-inch OD X 5.40-inch Enrichment FV
	8104239	Tube, 1/8-inch OD X 4.80-inch Enrichment DV
16	8101176	Tap, 1/8-inch NPT Pressure
17	8130377	Tee, 1/8-inch NPT Female
18	8130354	Elbow, 1/8-inch NPT X 1/8-inch Tube Compression
19	8130016	Nipple, 1/8-inch NPT X Close
20	8101006	Bushing, 1/4-inch NPT to 1/8-inch NPT Reducing
21	8130495	Tee, 1/4-inch Male NPT to Female NPT
22	8101025	Connector, 1/4-inch Male NPT to 3/8-inch Tube
23	8101026	Tee, 1/4-inch Male NPT to Female NPT Street
24	8130700	Nipple, 1/4-inch NPT x 3-inch

√ Recommended parts.

1.10 Filtration System Components

1.10.1 Filter Pan, Pump, Motor, and Associated Parts

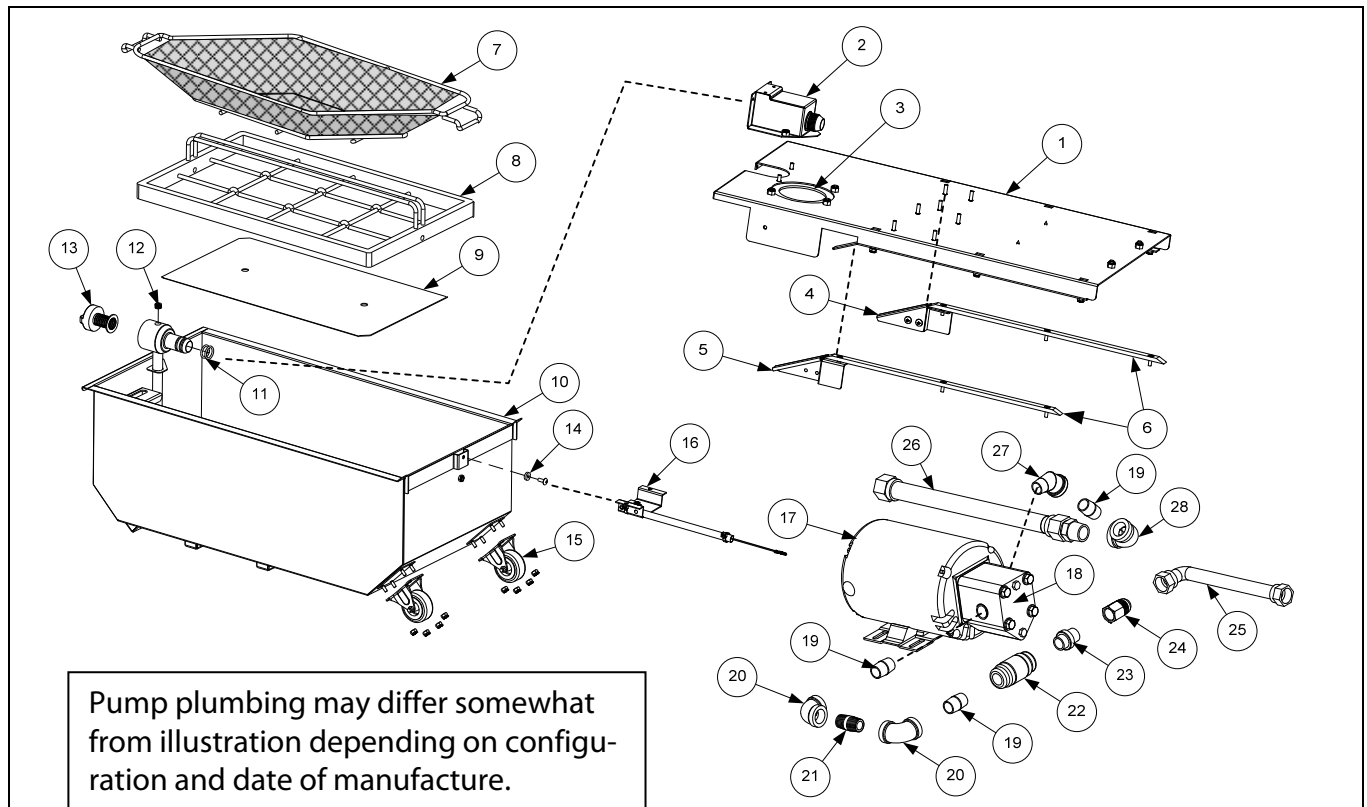

ITEM	PART #	COMPONENT
1	1087377	Bridge, Filter Pan Assembly
2	8239298	Mount, Female Suction
3	8160929	Gasket, Filter
4	1086673	Ramp Assy, Left Filter
5	1086674	Ramp Assy, Right Filter
6	8160927	Slide, Filter Pan
7	8104153	Basket, Crumb Tray 14 inch
8	8104152	Hold-Down Ring 14 inch
9	8122265	Sana Grid Filter Screen, 14 inch
10	1087930SP	Pan, Filter Assembly
√ 11	8263288	O-Ring (8161041) (Qty. of 6; used w/ Item 10)
12	8130989	Plug, 1/8-inch NPT Socket Head Pipe (used with Item 10)
13	8238335	Screen, Suction Line Filter
14	8103007	Magnet, Pull Ring
15	8102807	Caster, 2-inch Rigid
	1086263SP	Pan, Filter Assembly (includes items 7, 8, 9, and 10)
*	2401086	Wrench, Filter Screen
*	8104167	Lanyard, Filter Screen Wrench
16	1082218	Assembly, Filter Pan Switch Sensor
√ *	1065876SP	Sensor Assembly, Magnet Position
√ 17		Motor and Gasket Kit
	8261785	100V 50/60 Hz
	8261712	115V 50/60 Hz
	8261756	208V 50/60 Hz

* Not illustrated.

√ Recommended parts

1.10.1 Filter Pan, Pump, Motor, etc.

ITEM	PART #	COMPONENT
	8261270	220-240V 50/60 Hz
	8261755	250V 50/60 Hz
*	1084728	Cord, Filter Motor Power
√ 18	8263191	Pump and Gasket Kit, 4 GPM
	8160093	Gasket, Pump/Motor
*	8091062	Cap Screw, 5/16-inch-18 4.00" NC Hex (Connects pump to motor.)(8090194 washer)
19	8130022	Nipple, 1/2-inch x Close NPT BM
20	8130062	Elbow, 1/2-inch BM 90°
21	8130087	Nipple, 1/2-inch x 1.50-inches NPT BM
22	8100667	Check Valve 1/2-inch NPT 1 PSI
23	8103738	Adapter, Check Valve Close NPT
24	8101669	Adapter, Female 7/8-inch OD x 1/2-inch
25	8101043	Flexline, 1/2-inch x 9.50-inch (to oil manifold)
26	8104278	Flexline, 3/4-inch x 14-inch Oil Return (from filter pan)
27	8130342	Elbow, Street 45° x 1/2-inch NPT
28	8130068	Elbow, Reducing 3/4-inch x 1/2-inch
*	8101668	Adaptor, Male 5/8" OD x 1/2" - Connects between elbow on incoming side of pump and OQS sensor.
*	1063782	Heater Strip Assembly, 100-120V 25W 18"
*	1065427	Heater Strip Assembly, 208-250V 25W 18"

* Not illustrated.

√ Recommended parts.

1.10.2 Oil Quality Sensor (OQS) and Associated Parts

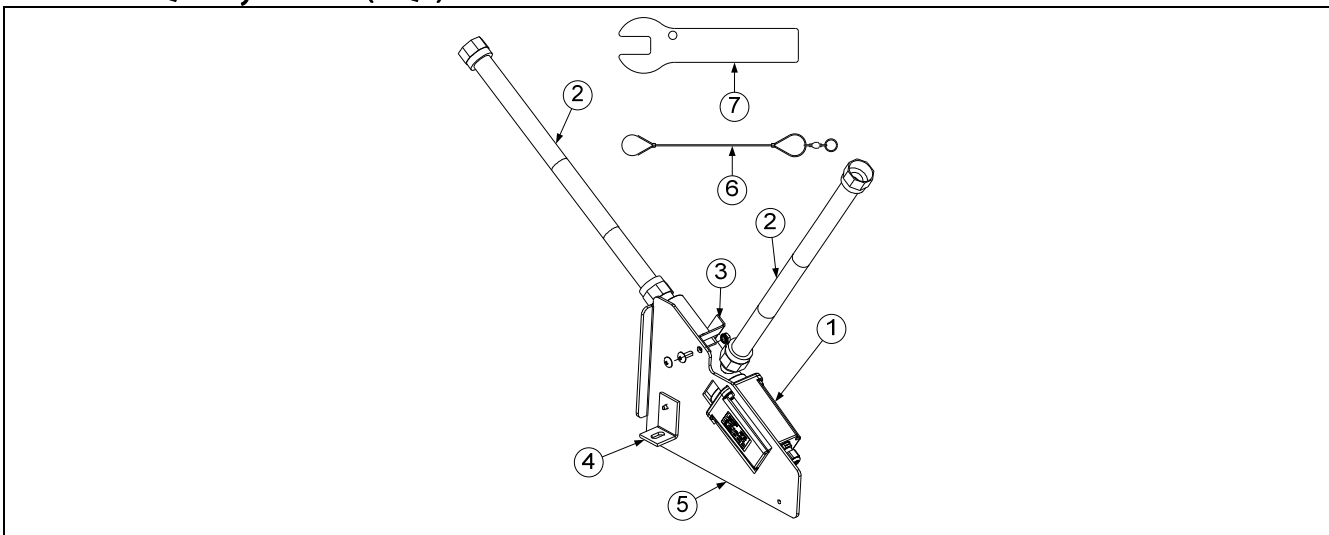

ITEM	PART #	COMPONENT
	8263495	Kit, OQS FQGLA-Touch Gas 2-5 Batt. (Kit to add to existing FQGLA-Touch Gas Fryers)
1	8263292	Sensor, FilterQuick OQS Replacement
2	8101057	Flexline, 5/8" OD x 13-inch
3	2401385	Retainer, OQS Sensor FQ
4	2401386	Brace, OQS Sensor Mount (on opposite side for 2-battery)
5	2401384	Mount, OQS Sensor FQ
6	8104167	Lanyard, In-Line Filter
7	2401086	Wrench, Pre-Filter Cap

1.11 ATO (Auto Top-Off) Components

1.11.1 JIB Cradle, JIB Cap / Pick-Up Assembly and JIB (ATO) Reset Switch

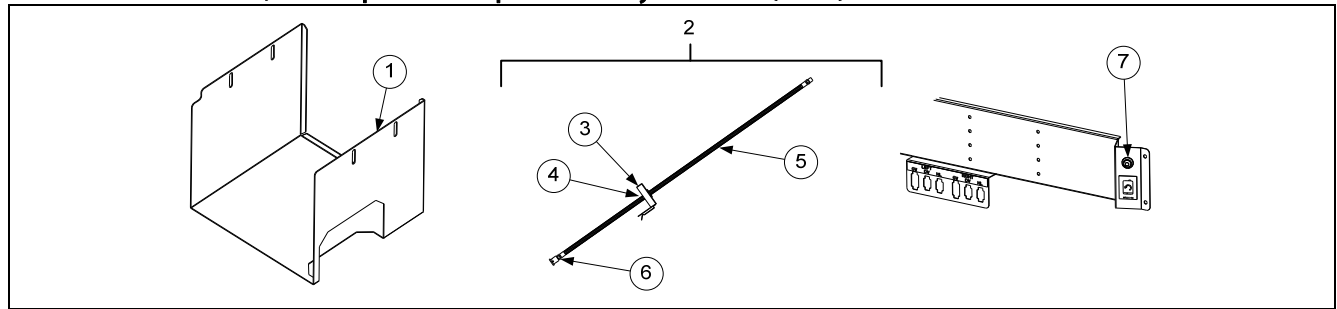

ITEM	PART #	COMPONENT
1	2209929	Cradle, JIB
2	1082005	Cap, JIB Assembly
3	8237736	Cap, JIB
4	8072469	Bushing, Heyco
5	8103823	Hose, JIB
6	8237738	Tip Assembly, JIB Suction Hose
√ 7	8074678	Switch, Momentary JIB Reset

√ Recommended parts.

1.11.2 ATO Pump Assembly – Non-Bulk

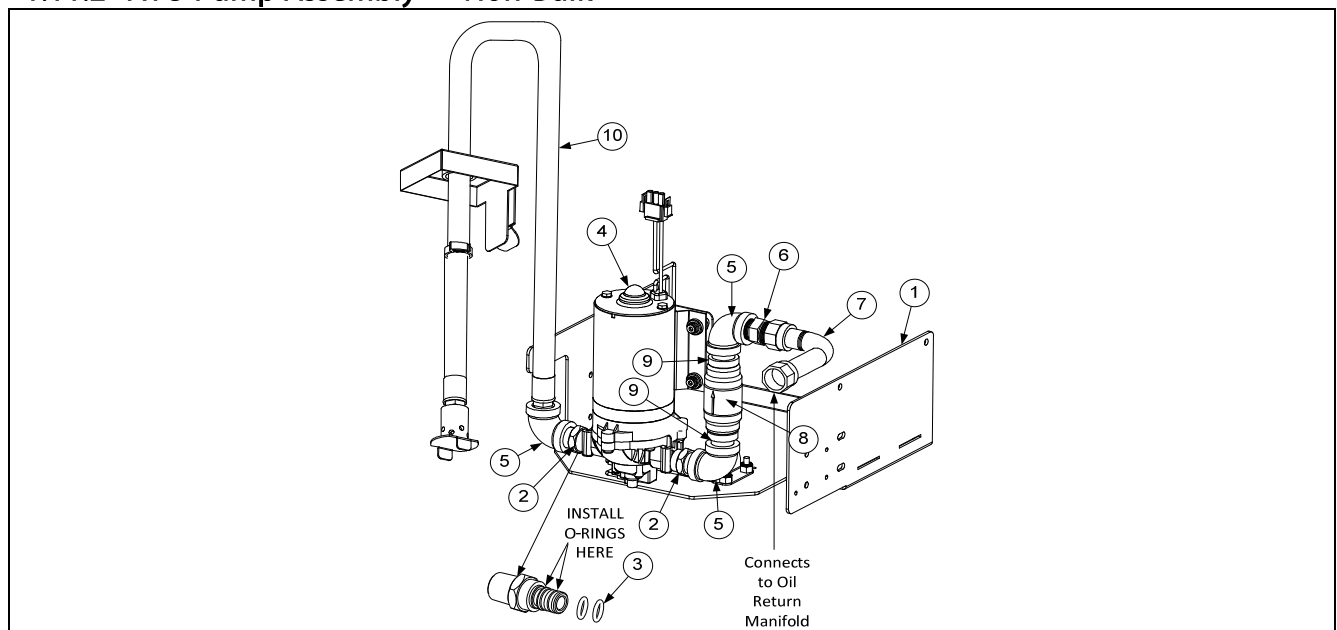

ITEM	PART #	COMPONENT
1	1085982	Tray, Top Off Stud Assy
2	8103820	Fitting, Quick Connect Shurflo Pump
√ 3	8160782	O-Ring, Viton #111
√ 4	1084372	Pump, ATO 24VDC
5	8130062	Elbow, ½-inch BM 90°
6	8101668	Adaptor, Male ¾" OD x ½"
7	8101680	Flexline, 5/8" OD x 6.50-inch
√ 8	8100667	Check valve, ½ NPT 1 PSI
9	8103738	Adapter, Check Valve Close NPT
10	1082005	Cap, JIB Assembly

√ Recommended parts.

1.11.3 ATO Pump Assembly – Bulk

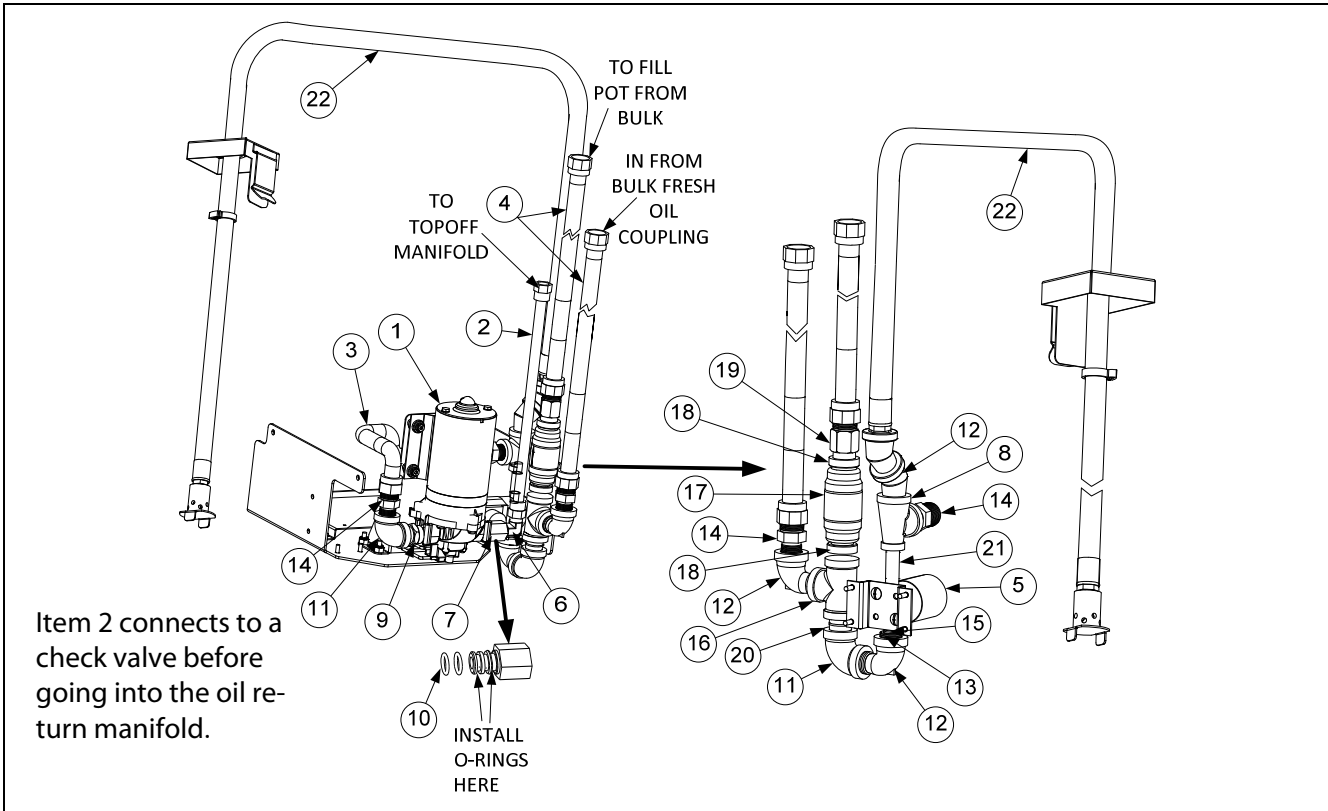

ITEM	PART #	COMPONENT
	1086060	Pump, Assy Top Off Bulk
√ 1	1084372	Pump, Shurflo 24VAC
2	8103375	Flexline, 1/2" OD x 17-inch (Out to oil check valve and to return manifold)
√ *	8100667	Check valve, 1/2 NPT 1 PSI
3	8101055	Flexline, 5/8" OD x 11.50-inch (Inlet to Top Off Pump)
4	8101369	Flexline, 5/8" OD x 17.50-inch
*	8103263	Flexline, 3/8" OD x 36-inch
*	8103264	Flexline, 5/8" OD x 42-inch
5	1066830	Solenoid
6	8130940	Elbow, 1/4" NPT x 3/8" Flare
7	1083403	Fitting, Shurflo Connect
8	8130530	Tee, Reducing 1/2" x 1/4" x 1/2"
9	1082054	Fitting Assy, Shurflo Connect
√ 10	8160782	O-Ring, Viton #111
11	8130062	Elbow, 1/2" BM 90°
12	8130165	Elbow, Street 1/2" x 1/2" NPT 90° BM
13	8130304	Bushing, BM Flush
14	8101668	Adaptor, Male 5/8" OD x 1/2"
15	8130838	Nipple, 1/4" NPT BM Close
16	8130003	Tee, 1/2" x 1/2" x 1/2" BM
√ 17	8103583	Check Valve 1/2" NPT 4 PSI
18	8103738	Adapter, Check Valve Close NPT
19	8101669	Adapter, Female 7/8" OD x 1/2"
20	8130022	Nipple, 1/2" x Close NPT BM
21	8130537	Nipple, 1/4" x 2.00" NPT
22	1082005	Cap, JIB Assembly
*	1086323	Heater, Low Oil Volume ATO Pump Inlet 100V 40W 56"

* Not illustrated. √ Recommended parts.

1.12 Bulk System Components
 1.12.1 Bulk Dispose Waste Valve

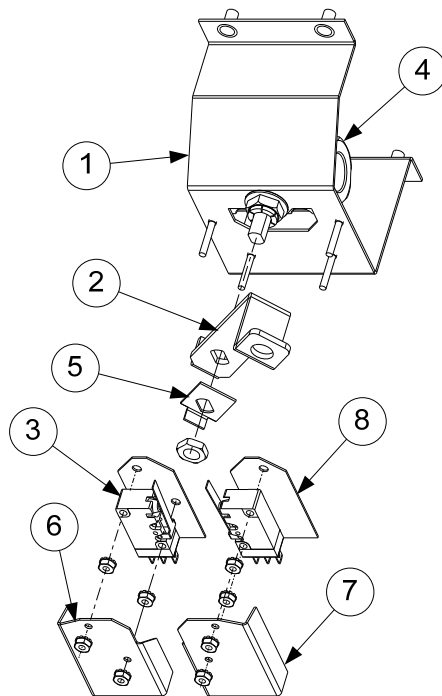

ITEM	PART #	COMPONENT
	1085923	Valve, Waste Dispose Low Oil Volume
1	1085922	Stud Assy, Waste Valve
2	2205899	Handle, Bulk Waste Valve
3	8074936	Microswitch, Gold Sealed
4	8100278	Valve, 1/2" Ball
5	9002935	Retainer, Nut Return Valve
6	9012348	Cover, DV Safety Switch
7	9022348	Cover, DV Safety Switch
8	8160220	Insulation, RF Switch

1.12.2 Bulk Manifold and Accessories

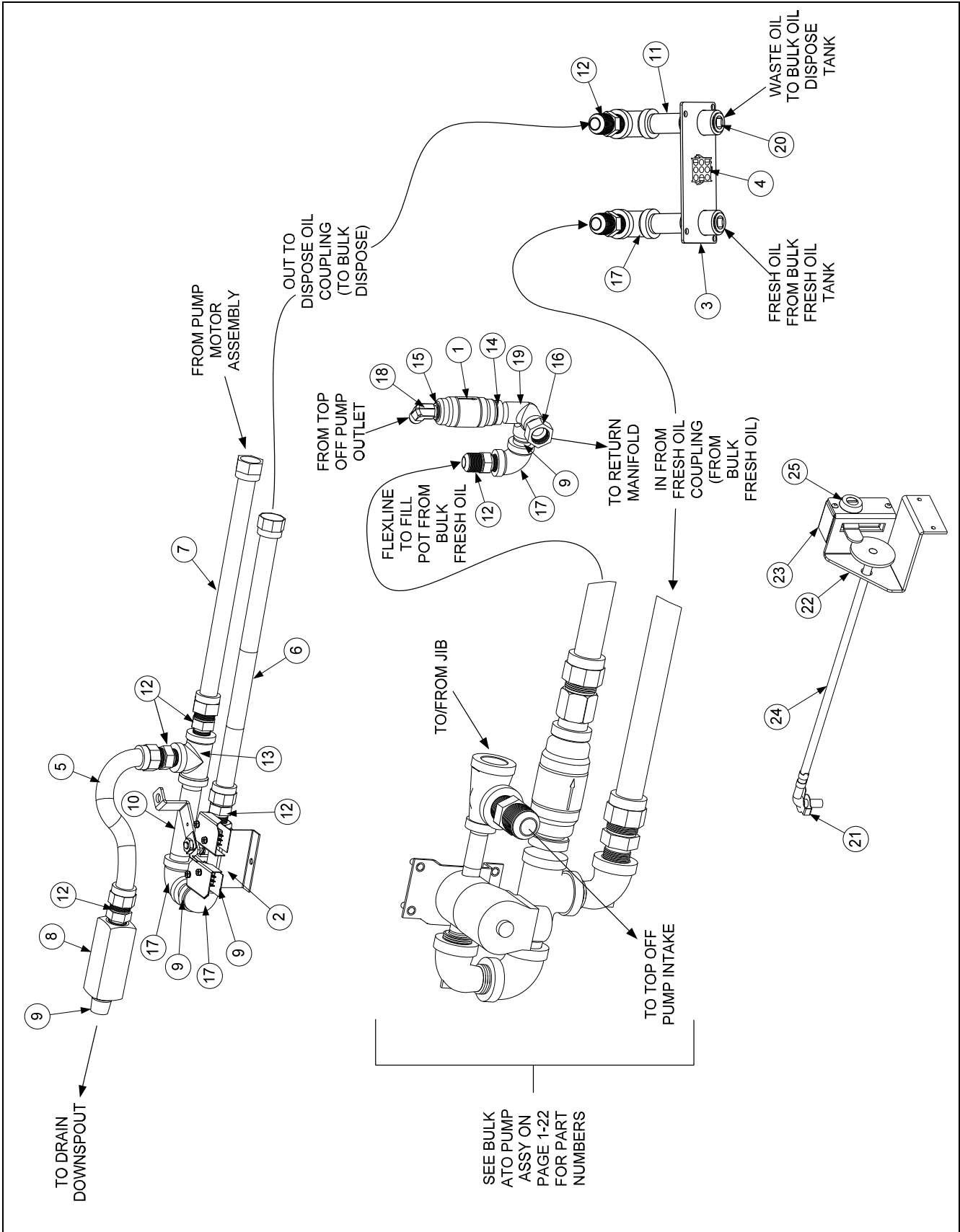

1.12.2 Bulk Manifold and Accessories cont.

ITEM	PART #	COMPONENT
√ 1	8100667	Valve, Check ½" NPT 1 PSI Bulk Manifold
2	1085923	Valve, Low Oil Volume Bulk Waste Assembly (see page 1-24 for parts)
3	8239299	Bracket, W/A, Touch Bulk Connections
4	8076105	Harness, Dispose/Pan Switch, Bulk
*	1085398SP	Bulk Oil Harness Pigtail
5	8101067	Flexline, ⅝" OD x 8.50-inches long
6	8101057	Flexline, ⅝" OD x 13-inches long
7	8101055	Flexline, ⅝" OD x 11.50-inches long
√ 8	8103531	Valve, 20 PSI Check Bulk
9	8130022	Nipple, ½" x Close NPT BM
10	8130251	Nipple, ½" x 4.50-inches NPT BM (used on 3, 4 and 5 battery units)
11	8130265	Nipple, ½-inch x 2.50-inches NPT BM
12	8101668	Adaptor, Male ⅝" OD x ½"
13	8130003	Tee, ½" x ½" x ½" BM
14	8103738	Adaptor, Check Valve Close Nipple
15	8130304	Bushing, ½" x ¼"
16	8103160	Adaptor, ½" NPT x 15/16"
17	8130062	Elbow, ½" BM 90°
18	8130940	Elbow, ¼" NPT x ⅜ Flare
19	8130331	Elbow, W/Side Outlet ½" NPT
20	8130463	Plug, Pipe ½" NPT
	1080686SP	Handle and Lock Assy, Gas Low Oil Volume Bulk
21	8090657	Clip, Clevis Right Rod End
22	2205656	Brace, Bulk Handle
23	2208664	Cover, Bulk Handle
24	8237208	Handle, Gas Low Oil Volume Bulk Waste Pull
25	8103587	Lock, Bulk Waste Handle (includes keys)

√ Recommended parts.

* Not illustrated.

1.13 Datalink System Components

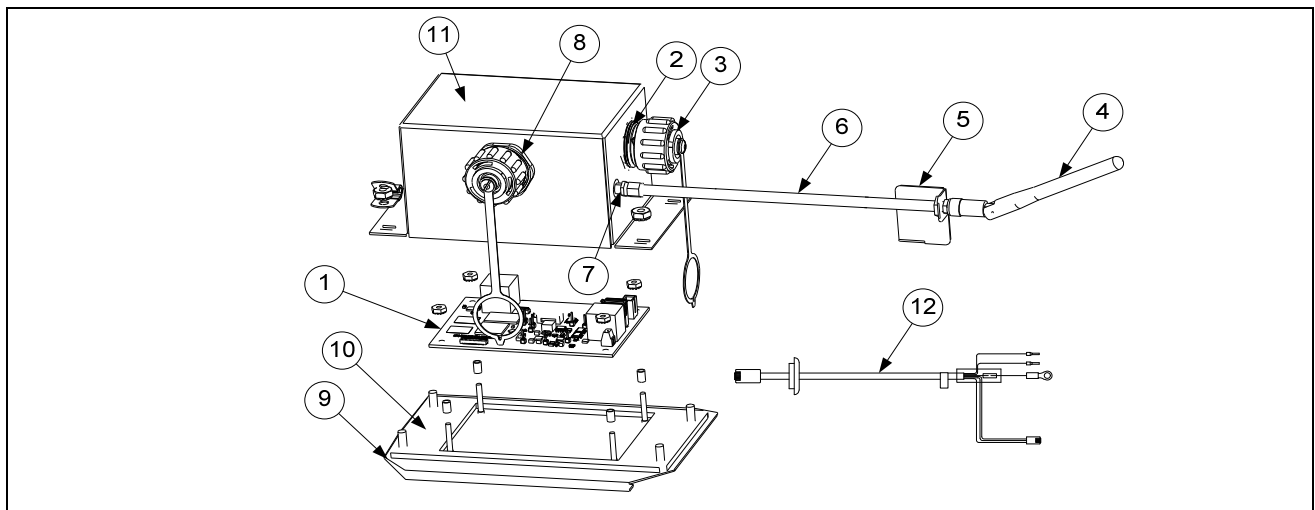

ITEM	PART #	COMPONENT
	1087456	Box Assy, FQ4000 KCCM Board
1	8076148	PCB, Assy FQ4000 KCCM/SUI
2	8075969	Cable, USB Receptacle Mount

1.13 Datalink System Components cont.

ITEM	PART #	COMPONENT
3	8075970	Cap, Dust
4	8075975	Antenna
5	2601847	Bracket, Remote Antenna
6	8076150	Cable. Coax
7	8076225	Cable, U. FL to RP-SMA Bulkhead
8	8075967	Coupler, 8PBC to 8PBC
9	1087160	Plate, Assy, Enclosure KCCM Board
10	8161076	Seal, Enclosure KCCM Board
11	8242437	Cover, Weldment, FQ4000 KCCM Board
12	8076149	Cable, FQ4000 KCCM Communication/Power
*	8075977	Cable, RJ45 7.87"
*	8075974	Power Supply, 24VDC, 15W for KCCM SUI board (Located inside the FIB – Filter/Topoff box)

1.14 Basket Lift Assy and Associated Parts

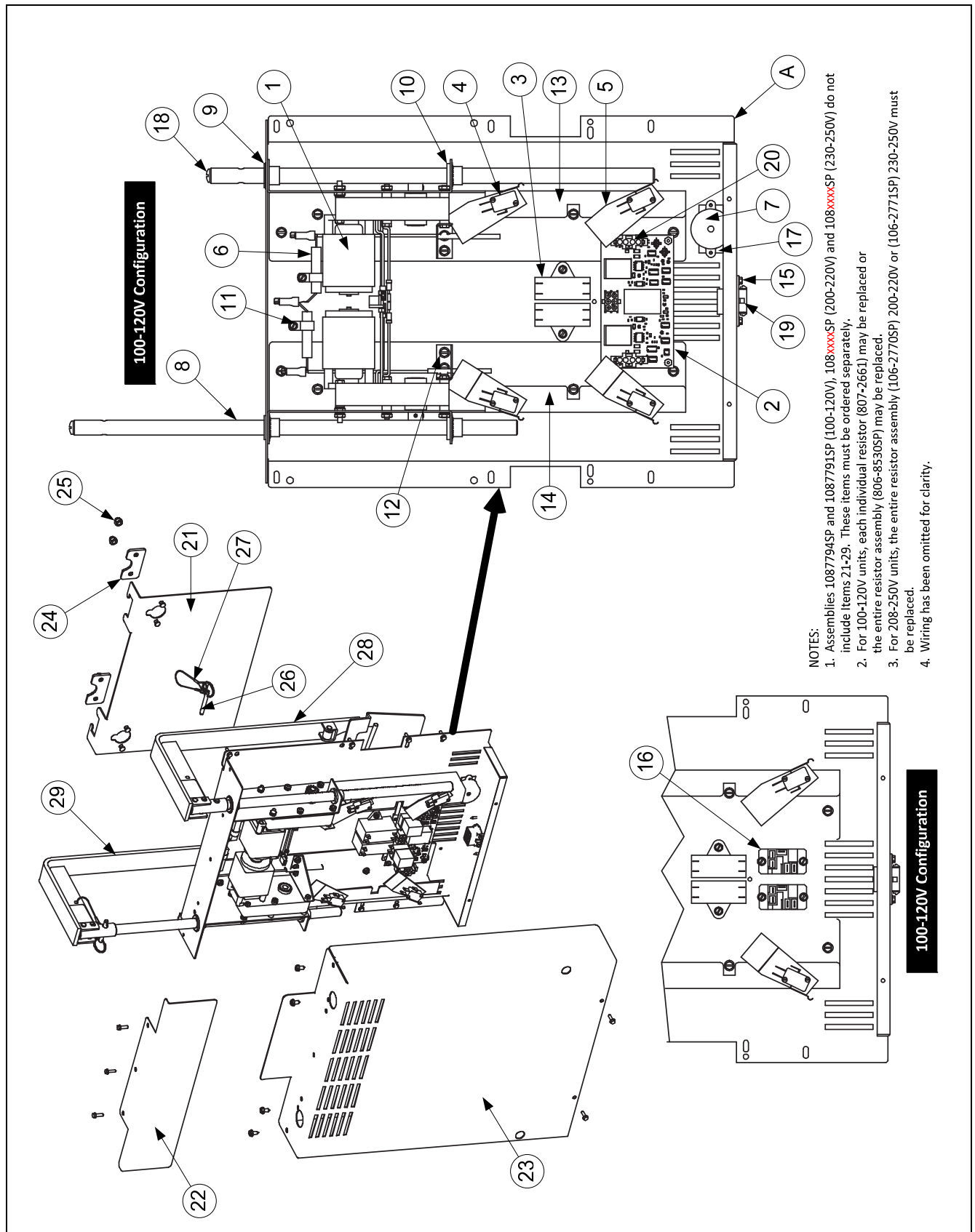

1.14 Basket Lift Assy and Associated Parts cont.

ITEM	PART #	COMPONENT
		Basket Lift Assemblies (see Note 1 in illustration)
A	1087794SP	Basket Lift Assy, 100-120VAC Reversing (Items 1-20) shown
B	1087791SP	Basket Lift Assy, 100-120VAC Non-Reversing (Items 1-20) partially shown
1	1084181SP	Motor Assy, 100-120VAC Modular Basket Lift
	1085031SP	Motor Assy, 208-250VAC Modular Basket Lift
2	4060070	PCB Assy, Basket Lift Reversing
3	8072513	Capacitor, 12.5 μ Fd 330VAC
4	8072572	Microswitch
5	8120442	Insulation, Microswitch
6		Resistor Assy
	8068530SP	100-120V Modular Basket Lift (see Note 2 in illustration)
	1062770SP	208-220VAC Modular Basket Lift
*	1062771SP	230-250VAC Modular Basket Lift
7	8103141	Sound Device
8	8104855	Rod, Modular BL w/Pin TB
9	8130035	Bushing, Bronze
10	8090082	Ring, Bushing Retainer
11	8090810	Clamp, Nylon
12	2400331	Gusset, Basket Lift Motor
13	2410330	Chassis, Left Basket Lift
14	2420330	Chassis, Right Basket Lift
15	2201415	Plate, Basket Lift Harness
16	8071683	Relay, 12VDC
17	8160862	Tape, 3M VHB 1.00 X 2.00
18	8090129	Screw, 1/4-20 X 5/8 Slotted Round Head
19	1087776	Harness, Reversing Modular BL
20	1087775	Harness, Reverse BL 4-Pin Connector
*	WIR1197	Wire Assy, Basket Lift Reverse 100-120VAC Basket Lift
*	WIR0166	Wire Assy, Basket Lift Reverse 200-250VAC Basket Lift
21	2602058	Guide, B/L Arm (differs from illustration shown)
22	2401693	Shield, Rear Modular B/L Cover
23	2401694	Cover, FQ4000 Modular B/L
24	2601474	Cover, Basket Hanger Rivet B/L
25	8090047	Nut, Cap 1/4" -20
26	8104852	Pin, 1/4" X 1-5/16" Quick Release
27	8104854	Lanyard, w/Ring
28	8239400	Arm, Left Basket Lift TB (use 8239435 for General Market)
29	8239401	Arm, Right Basket Lift TB (use 8239436 for General Market)

* Not illustrated.

1.15 Simplified FilterQuick™ FQGLA30-T Series Simplified Wiring

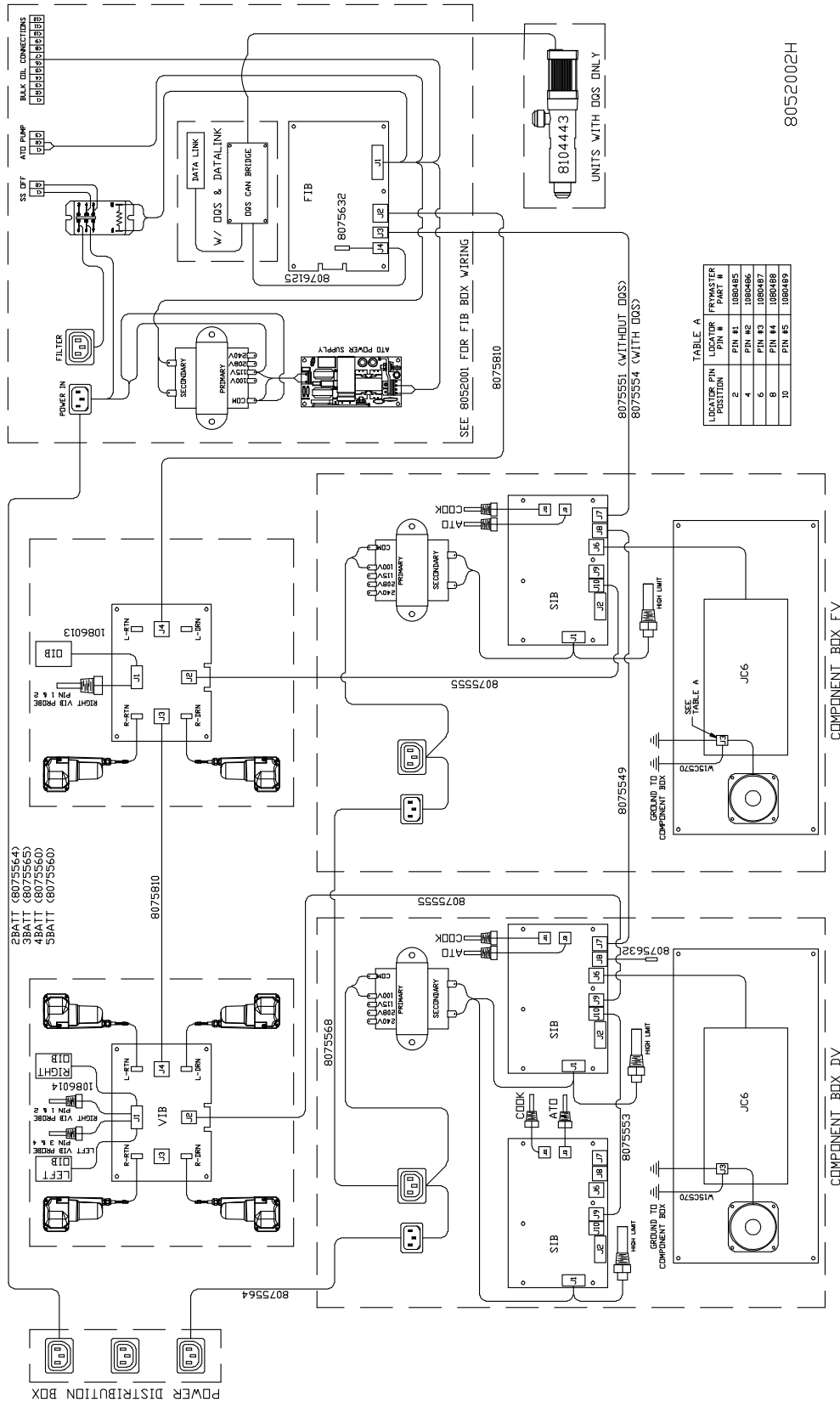

8052002H

THIS PAGE INTENTIONALLY LEFT BLANK

Frymaster[®]

FRYMASTER
8700 LINE AVENUE, SHREVEPORT, LA 71106-6800

800-551-8633
318-865-1711
WWW.FRYMASTER.COM
EMAIL: FRYSERVICE@WELBILT.COM



Welbilt offers fully-integrated kitchen systems. Welbilt's portfolio of award-winning brands includes Cleveland™, Convotherm®, Crystal Tips®, Dean®, Delfield®, Fabristeel®, Frymaster®, Garland®, Inducs®, Koldtech®, Kolpak®, Lincoln®, McCann's™, Merco®, Merrychef®, Multiplex®, RDI®, SerVend™, SunFire®, U.S. Range™, and WMaxx™. Supported by service brands: FitKitchen®, kitchen systems; and KitchenConnect®, cloud-based open platform.

Bringing innovation to the table • welbilt.com

©2024 Frymaster LLC. except where explicitly stated otherwise. All rights reserved. Continuing product improvement may necessitate change of specifications without notice.

Part Number FRY_P_8197446 05/2024