

Installation, Operation, & Maintenance

IOM 8501
Rev. H 04/24

EFE, EFW SERIES Space Constrained Unit w/ Energy Recovery Ventilation

ecoseries
FRESH-PAK[®]

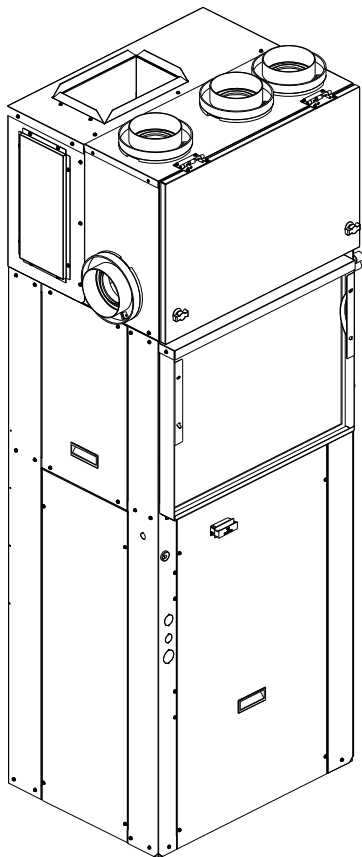

ATTENTION:

Read all instructions thoroughly and retain all manuals for future reference.



COPYRIGHT

The Manufacturer works to continually improve its products and as a result, it reserves the right to change design and specifications without notice.

The warranty may be void unless the Startup & Performance Checklist is completed and returned to the warrantor. If the FRESH-PAK unit is not installed properly the warranty will be void as the manufacturer cannot be held accountable for problems that stem from improper installation.

*****WARNING TO INSTALLER, SERVICE PERSONNEL AND OWNER*****

This appliance is not intended for use by persons (including children) with reduced physical, sensory or mental capabilities, or lack of experience and knowledge, unless they have been given supervision or instruction concerning use of the appliance by a person responsible for their safety. Children should be supervised to ensure they DO NOT play with the appliance.

Altering the product or replacing parts with non-authorized factory parts voids all warranty or implied warranty and may result in adverse operational performance and/or a possible hazardous safety condition to service personnel and occupants. Company employees and/or contractors are not authorized to waive this warning.

TABLE OF CONTENTS

SAFETY CONSIDERATIONS	4
MODEL NOMENCLATURE	5
GENERAL INFORMATION	6
INTRODUCTION	6
STORAGE	6
SHIPPING & PACKAGE LIST	7
UNIT INSPECTION CHECKLIST	8
UNIT DIMENSIONAL DATA	9
UNIT PHYSICAL DATA	10
ELECTRICAL DATA	11-12
INSTALLATION	13-22
INSTALLATION PRECAUTIONS	13
UNIT LOCATION	14
UNIT CLEARANCE REQUIREMENTS	15
WALL SLEEVE INSTALLATION	15-16
PACKAGED UNIT INSTALLATION	17-18
PIPING	19
DUCTWORK	20-21
CONDENSATE DRAIN	22
AIR FILTER	22
ELECTRICAL	23
CONTROLS	24-34
ECO SEQUENCE OF OPERATIONS – COOL MODE	24
ECO SERIES CONTROL MODULE	25
COOLING OPERATION	26
AUXILIARY HEATING OPERATION	27
ERV CONTROL MODULE	28
ERV DEFAULT CONFIGURATION	29-32
ERV ALARM FUNCTIONS	32
BLOWER SPEED CONTROL	33
BLOWER DATA	34-35
FIELD ERV ACCESSORIES	36-38
LOCATION OF MAJOR COMPONENTS	39
WIRING DIAGRAMS	40-46
CIRCUIT SCHEMATIC	47
STARTUP INSTRUCTIONS	48-49
TROUBLESHOOTING	50-51
ERV ALARM CODES	52-56
MAINTENANCE & SERVICE	57
PERFORMANCE TABLES	58
SUPPORT MATERIAL	59
STARTUP & PERFORMANCE CHECKLIST	60-61
NOTES	62

SAFETY CONSIDERATIONS

1. **READ THE ENTIRE MANUAL BEFORE STARTING THE INSTALLATION.**
2. These instructions are intended as a general guide and do not supersede national, state, or local codes in any way.
3. Altering the product, improper installation, or the use of unauthorized factory parts voids all warranty or implied warranty and may result in adverse operation and/or performance or may result in hazardous conditions to service personnel and occupants. Company employees or contractors are not authorized to waive this warning.
4. This product should only be installed and serviced by a qualified, licensed, and factory authorized installer or service agency.
5. All “kits”, parts, and “accessories” used must be factory authorized when modifying this product. Refer and follow instructions packaged with the kits or accessories when installing.

RECOGNIZE THE FOLLOWING SAFETY NOTATIONS THROUGHOUT THIS MANUAL AND POSTED ON THE EQUIPMENT:

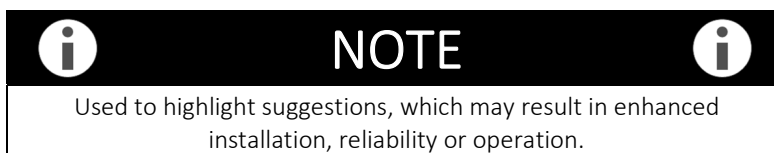

MODEL NOMENCLATURE

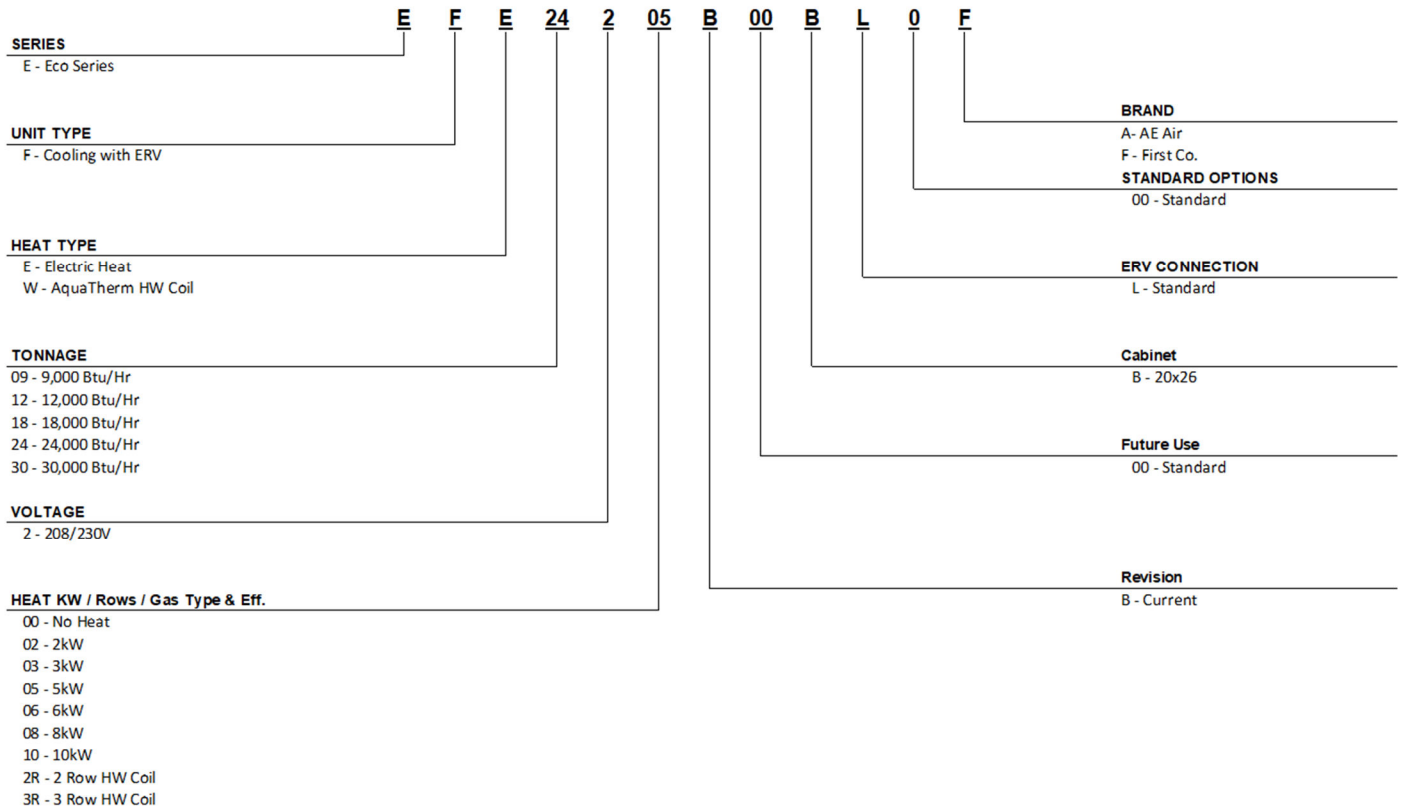







FIGURE 1 - Model Nomenclature



GENERAL INFORMATION

Clear surrounding area of all tools, equipment, and debris before operating this unit.

These instructions are given for the installation of the Eco Series FRESH-PAK specifically. For any other related equipment, refer to the appropriate manufacturer's instructions.

	CAUTION	
DO NOT use units during any phase of construction.		
Mechanical components and filters can become clogged with dirt and debris, which can cause damage to the system.		
The manufacture does not warrant equipment subjected to abuse. Construction debris can void warranties and liability for equipment failure, personal injury, and property damage.		

	WARNING	
	ELECTRIC SHOCK HAZARD	
ALWAYS turn off all power to the unit before servicing equipment. There may be more than one disconnect switch. All lockout/tag out procedures should be followed.		
Electrical shock can cause personal injury or death.		

	NOTE	
Material in this shipment has been inspected at the factory and released to the transportation agency in good condition.		
Upon receipt, a visual inspection of all cartons should be made immediately. Any evidence of rough handling or apparent damage should be noted on the delivery receipt in the presence of the carrier's representative.		
If damage is found, a claim should be immediately filed against the carrier.		

	CAUTION	
Extreme caution must be taken to ensure that no internal damage will result from screws that are drilled into the cabinet.		



INTRODUCTION

The FRESH-PAK unit is a combination of our high efficiency, high performance and reliable vertically packaged unit with an integral Energy Recovery Ventilation (ERV) System. ERVs provide pre-conditioned fresh outdoor air to your space either directly or through the normal return of your air handling unit. The benefits include improved indoor air-quality, reduced energy costs and lower first cost of installation. The FRESH-PAK, comes standard with ECM blowers for high efficiency and comfort and features. All FRESH-PAK models are certified to AHRI Standard 210/240-2020.

These installation instructions are intended as a general guide only, for use by an experienced, qualified contractor.

STORAGE

Equipment should be stored in a clean dry, conditioned area with maximum temperatures up to 120°F [48.89°C] and minimum temperatures to 32°F [0°C]. Units should be stored upright and in an indoor environment. It is recommended to leave packaging on the unit until the installation is to begin.

	WARNING	
Stacking the FRESH-PAK systems is strictly prohibited. Failure to follow this directive may result in system and/or property damage.		

DO NOT operate units during the construction process. Mechanical components and filters could become clogged with dirt and debris, which can cause damage to the system.

The manufacture does not warrant equipment subjected to abuse. Construction debris can void warranties and liability for equipment failure, personal injury, and property damage.

SHIPPING & PACKAGING LIST

SHIPPING INSTRUCTIONS

FRESH-PAK units must remain in the upright position throughout the shipping and handling process to maintain the proper compressor oil level.

PACKAGE LIST

The units will be shipped with the following. Quantities listed in Paratheses.

1. FRESH-PAK Package DX Cooling Unit with Integral ERV
 - a. Shipping brackets (2)
 - b. Screws (4)
 - c. Mounting bracket (2)
 - d. Screws (4)
2. Literature Package containing
 - a. IOM - Installation & Operations Manual (1)
3. Duct Collar Kit
 - a. ERV Round Duct Connections (4)
 - b. Screws (12)

Check the unit for shipping damage; if damage is found, immediately contact the last carrier.

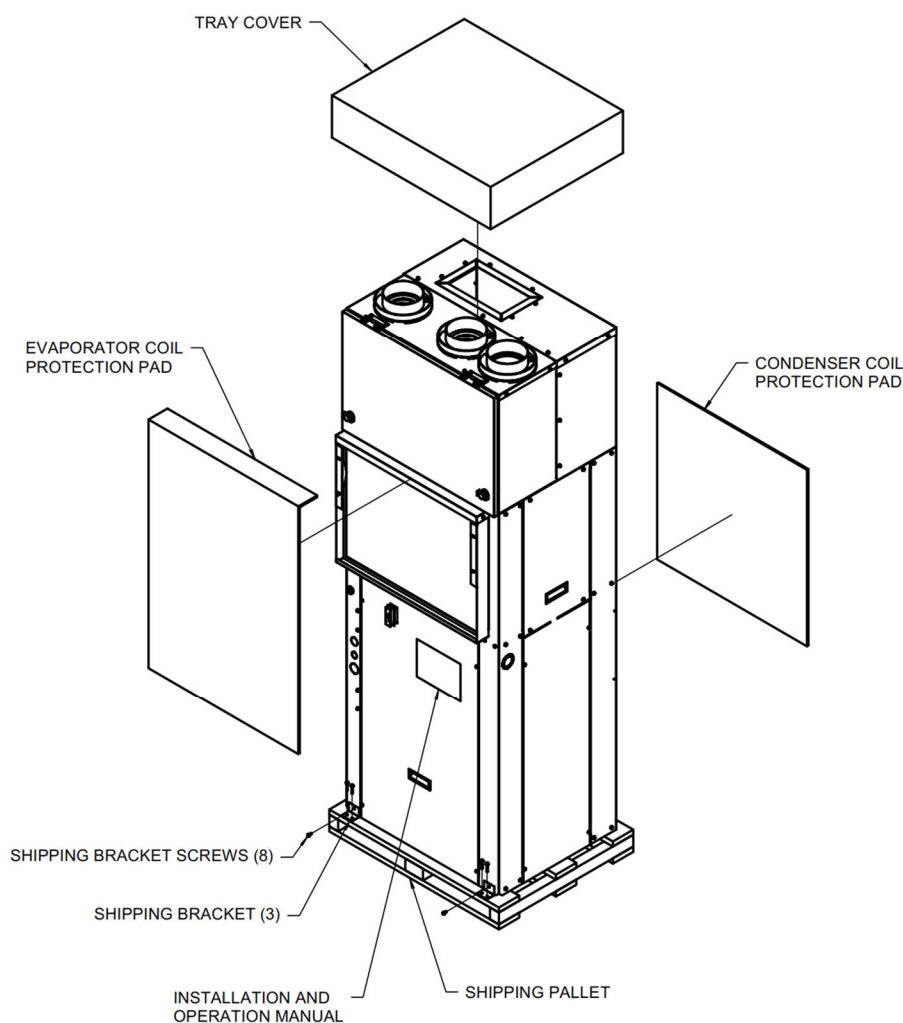

FIGURE 2 - Standard Packaging

UNIT INSPECTION CHECKLIST

Before preparing unit for installation, complete the inspection procedures below.

- 1) Visually inspect unit for any shipping damage. Damage must be reported immediately to the shipping company to make a claim.
- 2) Ensure that the carrier makes proper notation of any shortages or damage on all copies of the freight bill and completes a common carrier inspection report.
- 3) Verify that unit nameplates on the data label match the sales order or bill of lading (including, unit configuration, size and voltage).
- 4) Immediately before installation, remove unit front panel and verify that all electrical connections are tight and that there are no loose wires.
- 5) Verify that the refrigerant piping is free from any kinks and there is no interference between unit piping and sheet metal or electrical wires.
- 6) Remove the blower access panel and remove the foam packaging mount underneath the blower.
- 7) Check that the blower spins freely within the housing and there are no obstructions between the wheel and housing. The wheel can sometimes come loose in shipping.
- 8) Ensure that evaporator distributor tubes are not touching one another and that they are over the drain pan.
- 9) Check the air-coil fins for any damage during shipping.
- 10) Ensure that shipping brackets and screws are removed from condensing section. Refer to **FIGURE 3 - Standard Packaging with Brackets – Front View** & **FIGURE 4 - Standard Packaging with Brackets – Back View** for more information.

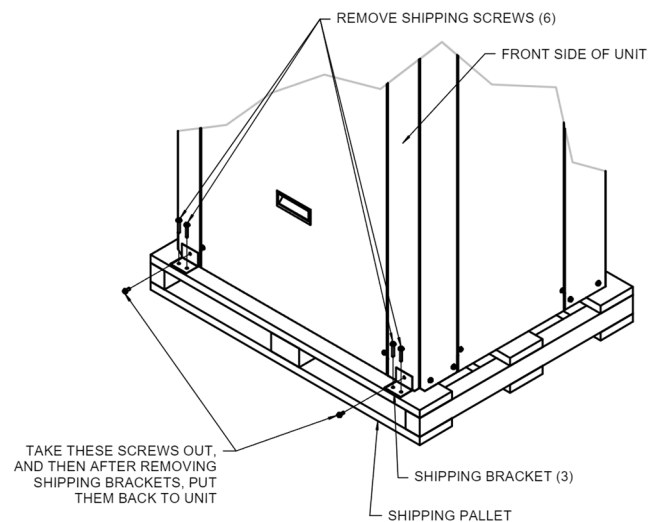

FIGURE 3 - Standard Packaging with Brackets – Front View

i	NOTE	i
<p>Check the unit nameplate for correct voltage with the plans before installing the equipment.</p> <p>Ensure that all electrical ground, connections are made in accordance with local code.</p>		

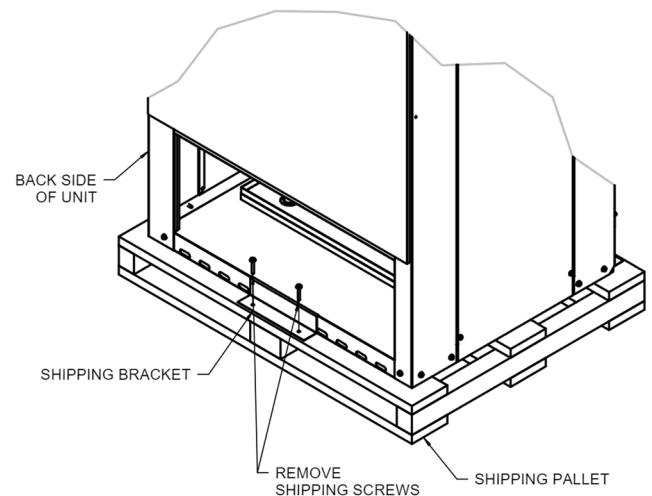

FIGURE 4 - Standard Packaging with Brackets – Back View

UNIT DIMENSIONAL DATA

DIMENSIONAL DATA				
MODEL	A	B	C	D
	SUPPLY CONNECTIONS			
09	4.00	10.00	5.25	2
12	4.00	10.00	5.25	2
18	7.00	11.25	4.125	4
24	7.00	11.25	4.125	4

Table 1 - Unit Dimensional Data

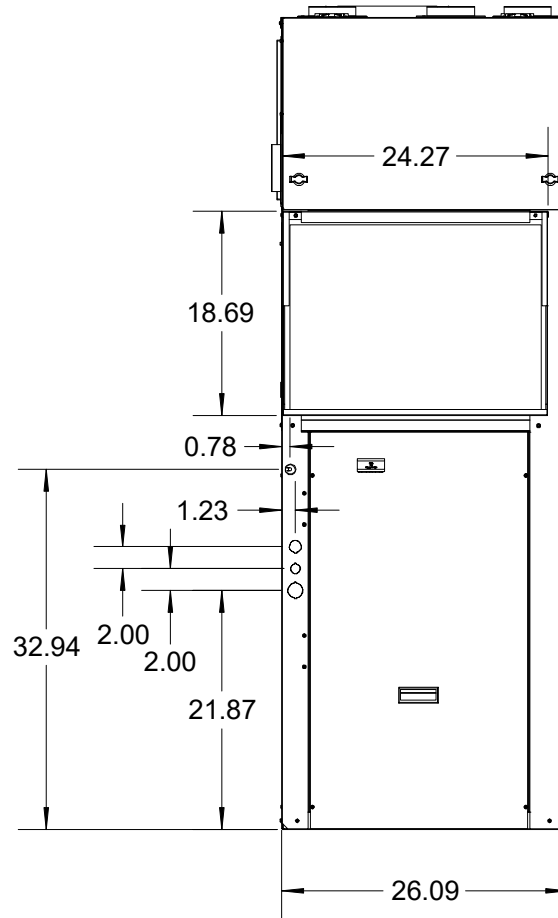
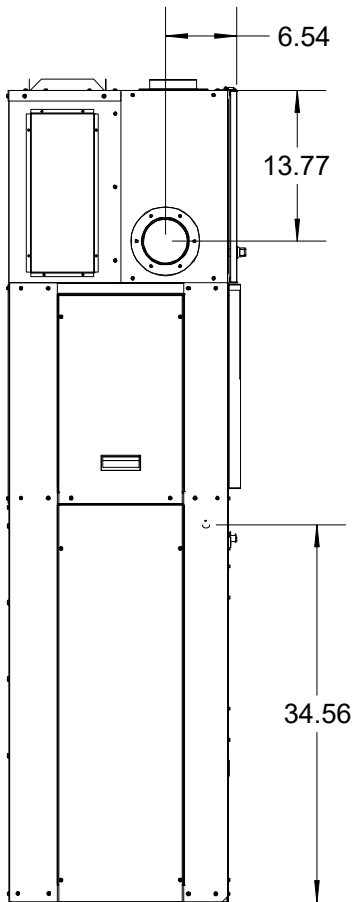
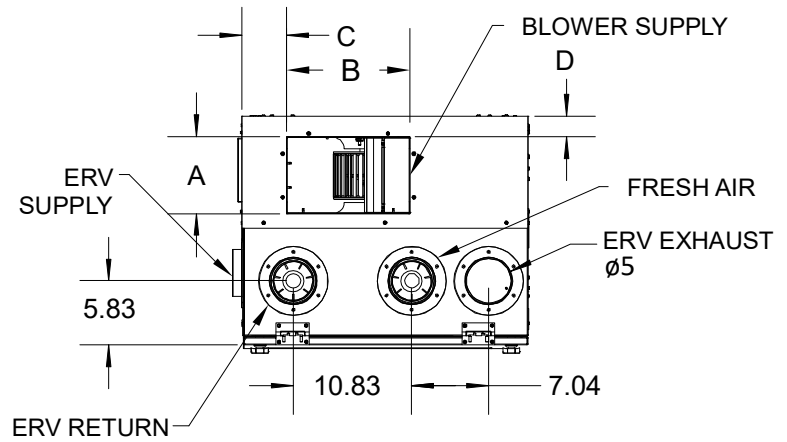

FIGURE 5 - Dimension

UNIT PHYSICAL DATA

PHYSICAL DATA										
FRESH-PAK Model	EFE09	EFW09	EFE12	EFW12	EFE18	EFW18	EFE24	EFW24	EFE30	EFW30
Compressor (Quantity)	Rotary (1)		Rotary (1)		Scroll (1)		Scroll (1)		Scroll (1)	
Factory Charge (R410A) lb. oz. [kg]	3lb 1.12oz [1.4]	3lb 1.12oz [1.4]	3lb 3.52oz [1.5]	3lb 3.52oz [1.5]	4lb 12.8oz [2.2]	4lb 12.8oz [2.2]	4lb 12.8oz [2.2]	4lb 12.8oz [2.2]	5lb [2.27]	5lb [2.27]
ID MOTOR										
Motor (Quantity)	1		1		1		1		1	
Fan Motor Type	ECM		ECM		ECM		ECM		ECM	
Motor HP	1/4		1/4		1/3	1/2	1/3	1/2	1/2	1/2
OD MOTOR										
Motor (Quantity)	1		1		1		1		1	
Fan Motor Type	ECM		ECM		ECM		ECM		ECM	
Motor HP	1/4		1/4		1/3		1/3		1/3	
ID BLOWER										
Blowers (Quantity)	1		1		1		1		1	
Blower Wheel Size (D x W) in. [cm]	9 x 7		9 x 7		10 x 7		10 x 7		10 x 7	
	[22.86 x 17.78]		[22.86 x 17.78]		[25.4 x 17.78]		[25.4 x 17.78]		[25.4 x 17.78]	
EVAPORATOR COIL										
Dimensions (H x W) in. [cm]	18 x 22 [45.72 x 55.88]		18 x 22 [45.72 x 55.88]		18 x 22 [45.72 x 55.88]		18 x 22 [45.72 x 55.88]		18 x 22 [45.72 x 55.88]	
Face Area ft ² [m ²]	2.75 [0.26]		2.75 [0.26]		2.75 [0.26]		2.75 [0.26]		2.75 [0.26]	
Rows	2		2		4		4		4	
OD COIL										
Dimensions (H x W) in. [cm]	26 x 22.5 [66 x 57]		26 x 22.5 [66 x 57]		26 x 22.5 [66 x 57]		26 x 22.5 [66 x 57]		26 x 22.5 [66 x 57]	
Face Area ft ² [m ²]	4.1 [0.3762]		4.1 [0.3762]		4.1 [0.3762]		4.1 [0.3762]		4.1 [0.3762]	
MISCELLANEOUS										
Throwaway Filter Dim. in. [cm]	18 x 24 [45.72 x 60.96]		18 x 24 [45.72 x 60.96]		18 x 24 [45.72 x 60.96]		18 x 24 [45.72 x 60.96]		18 x 24 [45.72 x 60.96]	
Throwaway Filter Quantity	1		1		1		1		1	
Operating Weight lb. [oz]	260 [117.9]		260 [117.9]		270 [122.5]		310 [140.6]		310 [140.6]	
Packaged Weight lb. [oz]	285 [129.3]		285 [129.3]		295 [133.8]		335 [152]		335 [152]	

Table 2 - Unit Physical Data Table

ELECTRICAL DATA

EFE ELECTRICAL DATA (208/230-1PH-60Hz)																
UNIT MODEL	ELECTRIC HEAT DATA						BLOWER DATA		CONDENSER DATA				MIN. CIRCUIT AMPACITY		MAX. CIRCUIT PROTECTION	
	kW		MBTUH		TOTAL HEATING AMPS		EVAPORATOR MOTOR		COMPRESSOR		CONDENSER MOTOR		208V	240V	208V	240V
	240V	208V	240V	208V	240V	208V	AMPS	HP	RLA	LRA	FLA	HP				
EFE09200	0	0.0	0.0	0.0	0.0	0.0	2.3	1/4	4.4	20	2.30	1/4	11	11	15	15
EFE09202	2	1.5	6.8	5.1	8.3	7.2							12	14	15	15
EFE09203	3	2.3	10.2	7.7	12.5	10.8							17	19	20	20
EFE09204	4	3.0	13.6	10.2	16.7	14.4							21	24	25	25
EFE12200	0	0.0	0.0	0.0	0.0	0.0	2.3	1/4	4.7	26	2.30	1/4	11	11	15	15
EFE12202	2	1.5	6.8	5.1	8.3	7.2							12	14	15	15
EFE12203	3	2.3	10.2	7.7	12.5	10.8							17	19	20	20
EFE12204	4	3.0	13.6	10.2	16.7	14.4							21	24	25	25
EFE12205	5	3.8	17.1	12.8	20.8	18.0							26	29	30	30
EFE18200	0	0.0	0.0	0.0	0.0	0.0	2.8	1/3	9.0	56	2.80	1/3	17	17	25	25
EFE18202	2	1.5	6.8	5.1	8.3	7.2							17	17	25	25
EFE18203	3	2.3	10.2	7.7	12.5	10.8							18	20	25	25
EFE18204	4	3.0	13.6	10.2	16.7	14.4							22	25	25	25
EFE18205	5	3.8	17.1	12.8	20.8	18.0							27	30	30	30
EFE18206	6	4.5	20.5	15.4	25.0	21.6							31	35	35	35
EFE18208	8	6.0	27.3	20.5	33.3	28.8							40	46	40	50
EFE18210	9	6.8	30.7	23.0	37.5	36.1							45	51	45	60
EFE24200	0	0.0	0.0	0.0	0.0	0.0							2.8	1/3	10.1	62
EFE24203	3	2.3	10.2	7.7	12.5	10.8	19	20	25	25						
EFE24204	4	3.0	13.6	10.2	16.7	14.4	22	25	25	25						
EFE24205	5	3.8	17.1	12.8	20.8	18.0	27	30	25	30						
EFE24206	6	4.5	20.5	15.4	25.0	21.6	31	35	35	35						
EFE24208	8	6.0	27.3	20.5	33.3	28.8	40	46	40	50						
EFE24210	9	6.8	30.7	23.0	37.5	36.1	45	51	45	60						
EFE30200	0	0.0	0.0	0.0	0.0	0.0	4.1	1/2	12.8	65	2.80	1/3	23	23	35	35
EFE30203	3	2.3	10.2	7.7	12.5	10.8							23	23	35	35
EFE30204	4	3.0	13.6	10.2	16.7	14.4							24	26	35	35
EFE30205	5	3.8	17.1	12.8	20.8	18.0							28	32	35	35
EFE30206	6	4.5	20.5	15.4	25.0	21.6							33	37	35	40
EFE30208	8	6.0	27.3	20.5	33.3	28.8							42	47	45	50
EFE30210	9	6.8	30.7	23.0	37.5	36.1							46	52	50	60

Table 3 - Unit Electrical Data Table (1)

ELECTRICAL DATA (continued)

EFW ELECTRICAL DATA (208/230-1PH-60Hz)										
UNIT MODEL	BLOWER DATA		CONDENSER DATA				MINIMUM CIRCUIT AMPACITY		MAXIMUM CIRCUIT PROTECTION	
	EVAPORATOR MOTOR		COMPRESSOR		CONDENSER MOTOR					
	AMPS	HP	RLA	LRA	FLA	HP	240V	208V	240V	208V
EFW0922RA	2.3	1/4	4.4	20	2.3	1/4	11	11	15	15
EFW0923RA										
EFW1222RA	2.3	1/4	4.7	26	2.3	1/4	11	11	15	15
EFW1223RA										
EFW1822RA	4.1	1/2	9.0	56	2.8	1/3	19	19	25	25
EFW1823RA										
EFW2422RA	4.1	1/2	10.1	62	2.8	1/3	20	20	25	25
EFW2423RA										
EFW3022RA	4.1	1/2	12.8	65	2.8	1/3	23	23	35	35
EFW3023RA										

Table 4 - Unit Electrical Data Table (3)

INSTALLATION

INSTALLATION PRECAUTIONS

CAUTION

Always wear all appropriate personal protection Equipment when installing and servicing units.

WARNING

Use multiple people to team lift when moving and installing these units.

Failure to properly lift units may result in personal injury or death.

CAUTION

Contact with metal edges and corners can result in personal injury. Protective gloves should be worn when handling. Exercise caution when installing and servicing unit.

Observe the following precautions for typical installation.

- Always use proper tools and equipment
- No wiring or any work should be attempted without first ensuring the unit is completely disconnected from the power source and locked out. Also, verify that a proper permanent and uninterrupted, ground connection exists prior to energizing power to the unit.
- Review unit nameplate and wiring diagram for proper voltage and control configurations. This information may vary from unit to unit.
- Units must be installed level to ensure proper drainage and operation.
- Be sure that the drain pan is free from foreign material prior to start up.

CAUTION

Components rotate at high speeds when the unit is in operation.

- Check filter media installation to ensure that it is installed correctly. Use the directional arrows or other information on the filter to determine the proper flow direction.
- Ensure air distribution system does not exceed the external static rating of the unit.

WARNING

When soldering and brazing, it is recommended that fire extinguishers be available. When soldering and brazing close to valves or sensitive components, heat shields or wet rags are required to prevent damage to the valves or components.

NOTE

Insulation is installed in the unit to provide a barrier between varying atmospheres outside and within the unit. If insulation is damaged condensation can occur and can lead to corrosion, component failure, and possible property damage.

Damaged insulation must be repaired prior to the operation of the unit. Insulation will lose its effectiveness and value when wet, torn, separated, and/or damaged.

CAUTION

When servicing this equipment, ensure that the reversing valve, expansion device, filter drier and other components are specifically designed for R-410A refrigerant.

ONLY USE service equipment specifically designated for use with R-410A.

WARNING

R-410A can become combustible if mixed with air at elevated temperature and/or pressure.

Failure to observe this warning may result in property damage, personal injury, or death.

INSTALLATION (continued)

UNIT LOCATION

This FRESH-PAK unit is certified for through-the-wall, indoor, up-flow vertical position installation only. This appliance is not design certified for installation in mobile homes, recreational vehicles, or outdoors. A factory approved wall sleeve must be used to install the FRESH-PAK unit.

The interior portion of the unit is surrounded by a closet with a rear access, refer to **FIGURE 6 - Condo with FRESH-PAK on Exterior Wall**. The vertical discharge allows for ducting to the top of the room for best air circulation and elimination of cold drafts on occupants. The exterior (grille side) of the unit must have no obstruction (trees, landscape material, etc.) within 30 in. [76.2 cm].

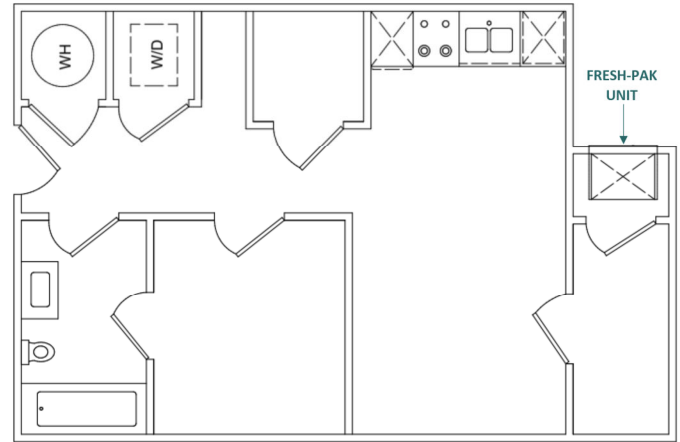

FIGURE 6 - Condo with FRESH-PAK on Exterior Wall

NOTE
Do not locate two units adjacent to each other on an inside corner or where they may exhaust into each other.

Provisions should be made to allow access to the indoor side of the unit for installation and inspection. The closet or access panel opening must be centered with the exterior wall opening and be at least 30 in. [76.2 cm] wide by 84 in. [213.36 cm] tall for all FRESH-PAK models.

12 in. [30.4 cm] (6 in. [15.24 cm] on sides without the ERV fresh air connection) of unobstructed clearance must be maintained around the FRESH-PAK chassis for adequate airflow to achieve optimum performance. These guidelines address minimum spacing requirements only. It is acceptable to go beyond these limits at any time. At least 29 in. [73.66 cm] of unobstructed space should be provided in front of the access door to permit removal of the unit, should repair and inspection be required.

NOTE
The FRESH-PAK units are designed for quiet operation. However, all air conditioning equipment will transfer a level of noise to the conditioned space. This should be considered when planning the location of the equipment.

NOTE
The Architectural Grille must be installed prior to the installation of the FRESH-PAK unit into the sleeve.

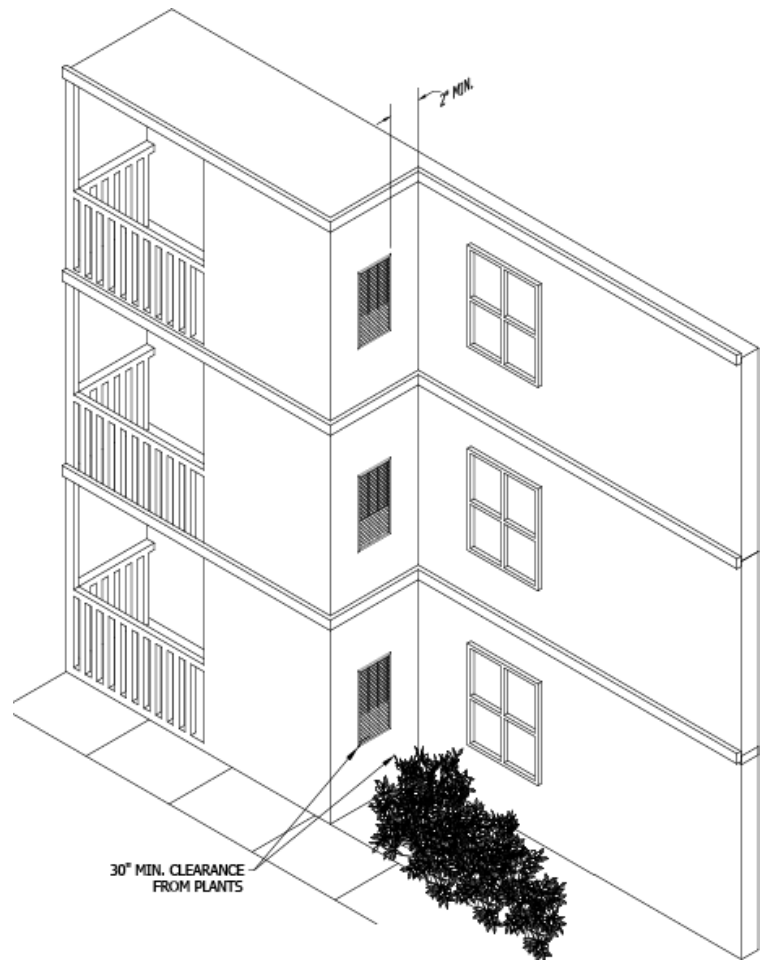

FIGURE 7 - Required Building Clearances

INSTALLATION (continued)

UNIT CLEARANCE REQUIREMENTS

Service clearance must be provided for future maintenance and service. A minimum of 29 in. [73.66 cm] open area must be left unobstructed in front of the access panels.

The grille side must be kept free from any obstructions to air flow. The unit must be installed at least 4 feet [1.22m] from electric meters, gas meters, regulators, and relief equipment.

CLEARANCE REQUIREMENTS		
MINIMUM CLEARANCE	INCHES	CM
Horizontal distance between units	12	30
Vertical distance between units	60	152
Distance above ground level	6	15
Distance above finished floor	6	15
Distance above a garage floor	18	46

Table 5 - Clearance Requirements

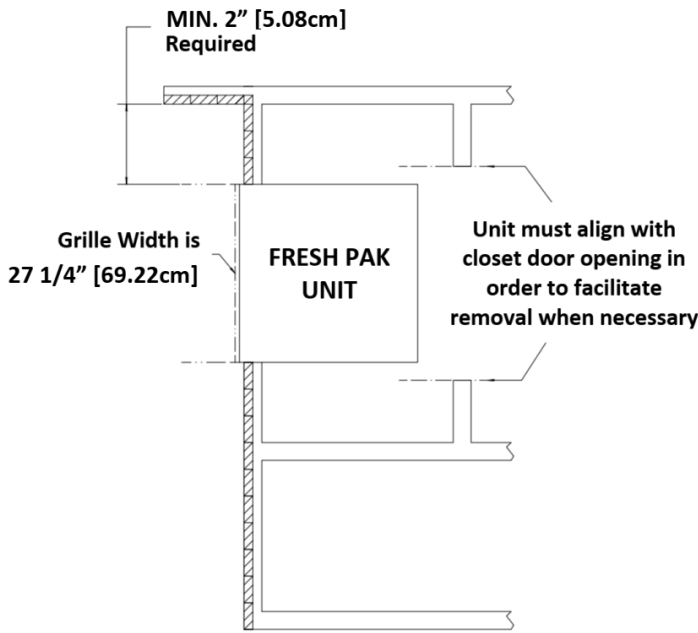

FIGURE 8 - Clearance Requirements

A unit installed in a garage must also be protected from damage by vehicles.

WALL SLEEVE INSTALLATION

Refer to installation instruction packed with the wall sleeve to assemble and mount into the wall. Before unit installation, verify that sleeve components are not damaged and that the drain line is unobstructed free of leaks.

Check all seals to ensure that they are in position and un-damaged. Ensure that the wall sleeve is sloped toward the exterior of the building. Securely fasten the Architectural grille to the front of the sleeve using the supplied hardware.

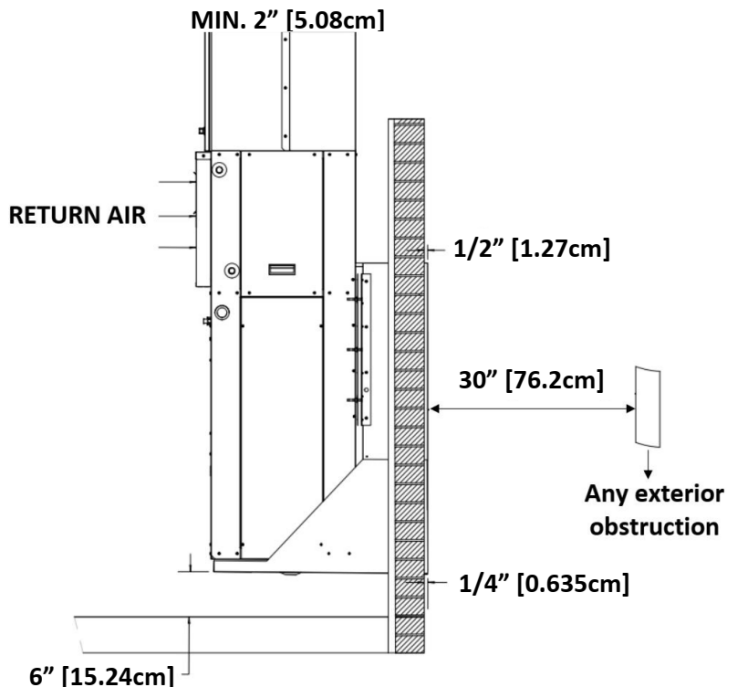

FIGURE 9 - Wall Sleeve Mounting

IMPORTANT

After sleeve installation, ensure that the gap in-between the wall and seal is insulated and is in contact with the sleeve sides.

IMPORTANT

Apply a high grade non-hardening sealant approved for exterior at the following locations to prevent air and water from migrating inside:

1. Between edge of the sleeve and the structure
2. On the inside/outside walls.

INSTALLATION (continued)

WALL SLEEVE INSTALLATION CONTINUED

REAR INSTALLATION & DIMENSIONS

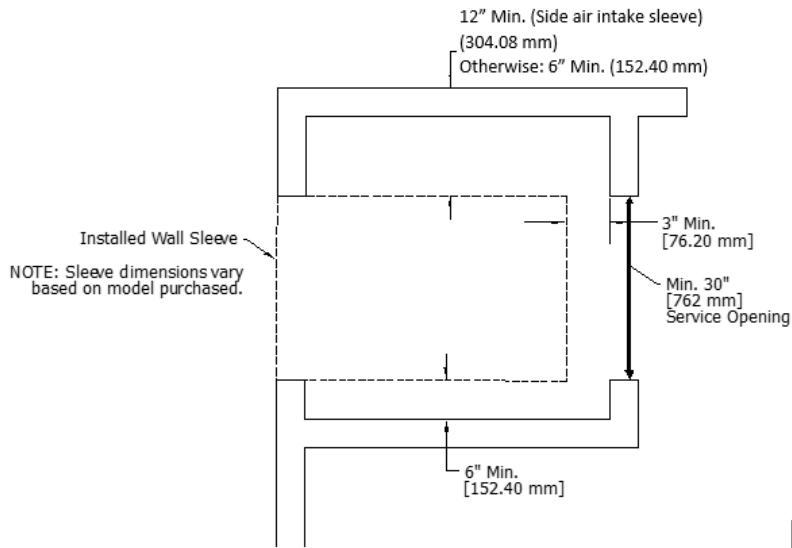

FIGURE 10 - Rear Installation

- Sleeve rough-in opening is 43-1/2 in. (H) [110.49 cm] x 26-3/4 in. (W) [67.94 cm].
- Bottom of opening should be approximately 6 in. [15.24 cm] about the floor.
- Minimum of 12 in. [30.4 cm] clearance required for side air intake sleeve insulation.
- Minimum of 6 in. [15.24 cm] clearance is required on the ERV fresh air (supply air) side.
- Minimum of 3 in. [7.62 cm] of clearance is required on all sides, except ERV fresh air (supply air) side, of the FRESH-PAK unit. See - FIGURE 10- Rear Installation.



NOTE



Sleeve dimensions differ across models.

INSTALLATION (continued)

PACKAGED UNIT INSTALLATION

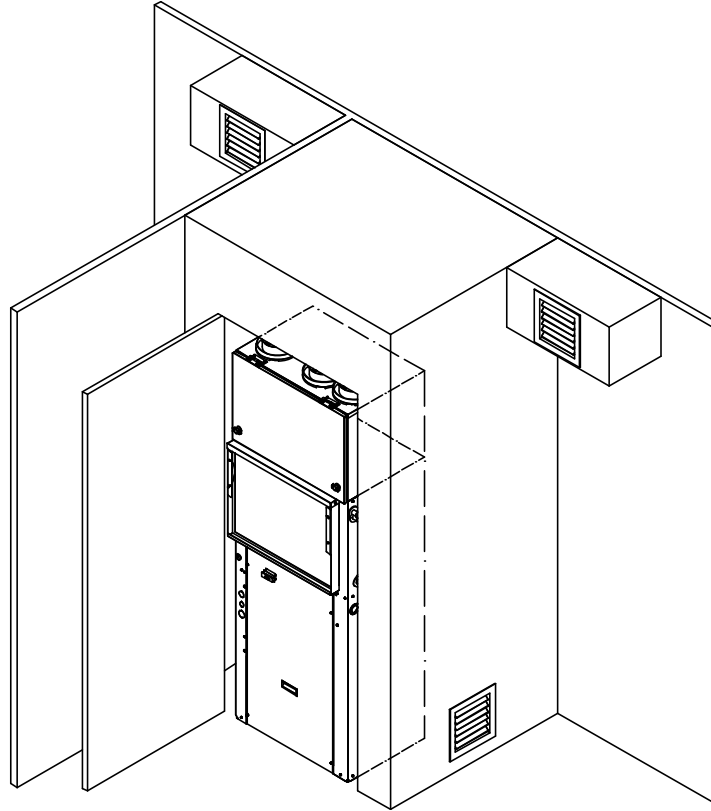

FIGURE 11 - FRESH-PAK Unit Installation



NOTE



Locate the unit in an area that provides minimum clearance to all service access panels. Consider all additional clearances needed for water connections, electrical connections, duct connections and sufficient return airflow.



IMPORTANT



Units are **ONLY** intended for indoor installation applications.



NOTE



DO NOT install unit in areas subject to freezing temperatures or where high humidity levels could cause cabinet condensation.

Units should be mounted on the sleeve with a pitch to the outside of the building.

Insulation is installed in indoor equipment to provide a barrier between outside air conditions surrounding the unit and the varying conditions inside the unit. If the insulating barrier is damaged, the surrounding ambient air will affect the inside surface temperature of the

cabinet; this may lead to sheet metal corrosion and subsequently, component failure.



IMPORTANT



Damaged insulation must be repaired or replaced before the unit is placed back into operation.

Insulation loses its insulating properties when wet, damaged, separated, or torn.

The installer must adhere strictly to all local and national code requirements pertaining to the installation of this equipment. All units are designed for indoor use only, and are agency listed for installation with clearances specified in **Table 5- Clearance Requirements**. This includes the cabinet, discharge plenum and connecting ducts.



NOTE



Check nameplate voltage, amperage and fuse size to ensure the proper power supply.

INSTALLATION (continued)

PACKAGED UNIT INSTALLATION

1. Remove the two shipping brackets holding the unit to the shipping pallet and remove unit from the shipping pallet.

NOTE

The top mounting bracket must be attached to the FRESH-PAK unit. The supply flanges are shipped in a flat configuration. The discharge duct flanges must be bent up at a 90° angle for installation

2. Ensure that properly sized ductwork is in place to mate to the connections on the FRESH-PAK.
3. Before setting unit into closet, remove upper side access panel and inspect the evaporator blower to ensure that the wheel turns freely without rubbing on the housing.

NOTE

Remove the Styrofoam shipping block supporting the blower assembly.

4. Replace upper access doors prior to completing installation.
5. Remove the disconnect and the rear access door to get to the loose items described in the packing list. Check all electrical connections and check the condenser fan to see if it turns freely.
6. Remove the 4 ERV duct collars from inside the cabinet.
7. Attach unit mounting brackets (2) as shown in **FIGURE 12 - Mounting Brackets Installation**.

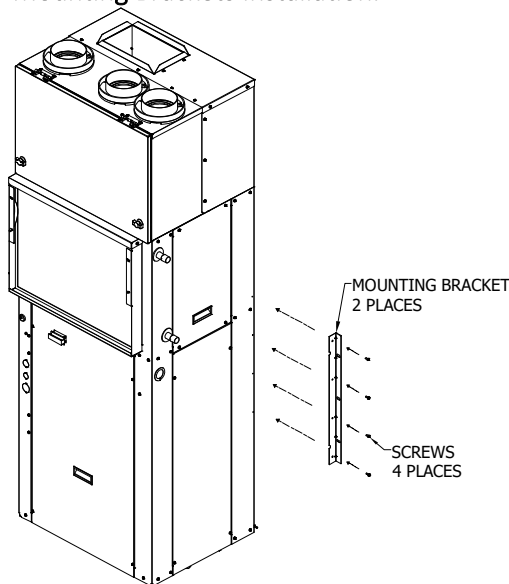

FIGURE 12 - Mounting Brackets Installation

8. Ensure that the wall sleeve is installed squarely and is secured before installing the unit.

IMPORTANT

After removing the construction debris guard, check the bottom of the sleeve pan to ensure that it is sloped toward the building exterior. Ensure that the bottom of the pan and drain are clear of obstruction and are operational.

NOTE

Inspect the sleeve seal, which is supplied with the sleeve, to ensure that it is properly secured and aligned. Use a high-grade non-hardening sealant to close any gaps that may exist between the seal and the wall of the sleeve.

9. After the seal is inspected, lift the unit onto the base of the sleeve and slide the unit forward to engage the seal. The unit uses locking brackets with weld studs. Align the unit to the bracket on the sleeve. Tighten down the unit until there is a tight seal with the sleeve. See **FIGURE 13 - Wall Sleeve Seal**.

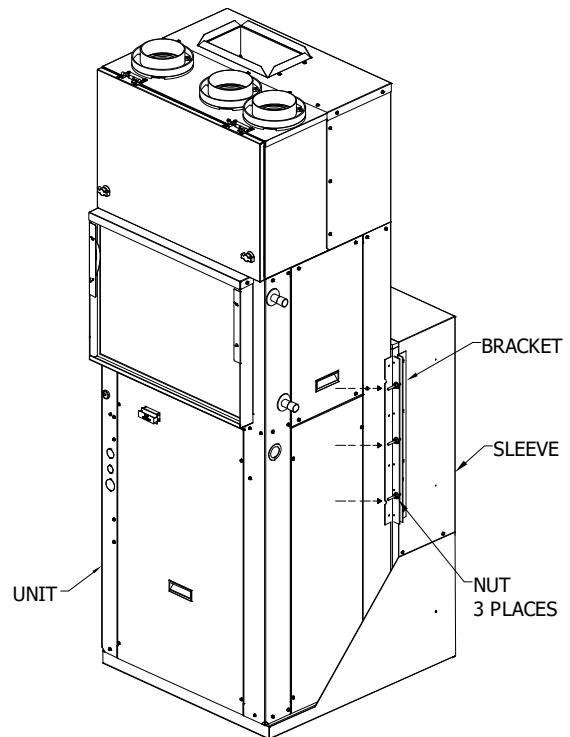

FIGURE 13 - Wall Sleeve Seal

10. Check that the unit is completely seated on all four sides against the wall sleeve seals.

CAUTION

If unit is not sealed properly, water and/or outside air will infiltrate the closet which may cause improper unit operation and can cause damage to the unit and/or property.

INSTALLATION (continued)

PIPING (HOT WATER COILS)



CAUTION



Prior to making piping connections, contractor must clean and flush water loop system. Failure to clean/flush system may result in nuisance tripping and premature component failure.

PIPING NOTES

1. Flush all field piping prior to connection to clear all debris.
2. Open all valves (mid-way for hand valves, manually open motorized valves) prior to soldering and brazing. Use proper heat shields to protect valve bodies.
3. When soldering or brazing to the unit, it is recommended to have a fire extinguisher readily available.
4. Use proper soldering and brazing techniques to protect valve bodies and unit components.
5. Heat can only be applied to the cup of the valve body for a minimal time before damage occurs (even with the use of wet rags).
6. Avoid rapid quenching of soldered joints to prevent weakening.
7. Make provisions for expansion and contraction of piping systems to provide movement with temperature changes. Failure to account for these factors will result in damage and failure of piping, fittings, and valves throughout the system.
8. **DO NOT** insulate the heads or motorized portion of control valves. Excessive heat build-up can cause damage and affect proper operation of the system.
9. Consider electrical routing when installing field piping.
10. Observe all regulations and codes governing installation of piping.



CAUTION



Hydronic systems are not designed to hold pressurized air and should only be tested with water.

Pressurizing system with air could damage equipment.



WARNING



Do not exceed 180 degree F (82 degrees C) water temperature..

When all connections are complete, pressure test the system, and repair any leaks or faulty joints.

PIPING INSTALLATION

1. All piping must be adequately sized to meet the design water flow requirements as specified for the specific installation. Piping must be installed in accordance with all applicable codes.
2. The piping connection on the equipment are not necessarily indicative of the proper supply and return line sizes. To minimize restrictions, piping design should be kept as simple as possible.



CAUTION



Do not bend or crimp the supply lines or hoses.

For all supply lines or hoses of 1.5 in. O.D. or larger, use properly sized fittings to prevent piping damage and potential restrictions in water flow.

3. Prior to connecting the FRESH-PAK all external piping must be purged of debris.
4. It is also recommended that all piping be insulated to prevent freezing when piping is run in all unconditioned spaces.



NOTE



Coil freeze protection is recommended for applications where the FRESH-PAK w/Hot Water is located in ambient air locations or within structures that may be unoccupied during freezing conditions.

Consult the Manufacturer for additional information.

INSTALLATION (continued)

DUCTWORK

Discharge ductwork is normally used with these units. When return air ductwork is required, the unit is supplied with 2 in. [5.08 cm] thick filter rack/duct collar for connection of return air ductwork. All ductwork must be installed in accordance with National Fire Protection Assoc. Codes 90A and 90B.

Supply and Return ducts must be sized properly as to not exceed static pressure capabilities of the unit. Ducts should be adequately insulated to prevent condensation and to minimize heat loss. A flexible connector is recommended for supply air connections on metal duct systems.

DISCHARGE DUCTING

All Ductwork must conform to industry standards of good practice as described in ASHRAE System Guide. The transition piece from the unit discharge to the duct distribution system must not have an angle greater than 30° or severe loss of air performance can result.

Do not connect the full duct size to the unit discharge collar without using a transition piece down to the size of the unit discharge collar. With metal material, the sides of the elbow and entire branch duct should be internally lined with acoustic insulation for sound attenuation.

The ductwork should be configured such that there is no line of sight between the unit discharge and the distribution diffusers.

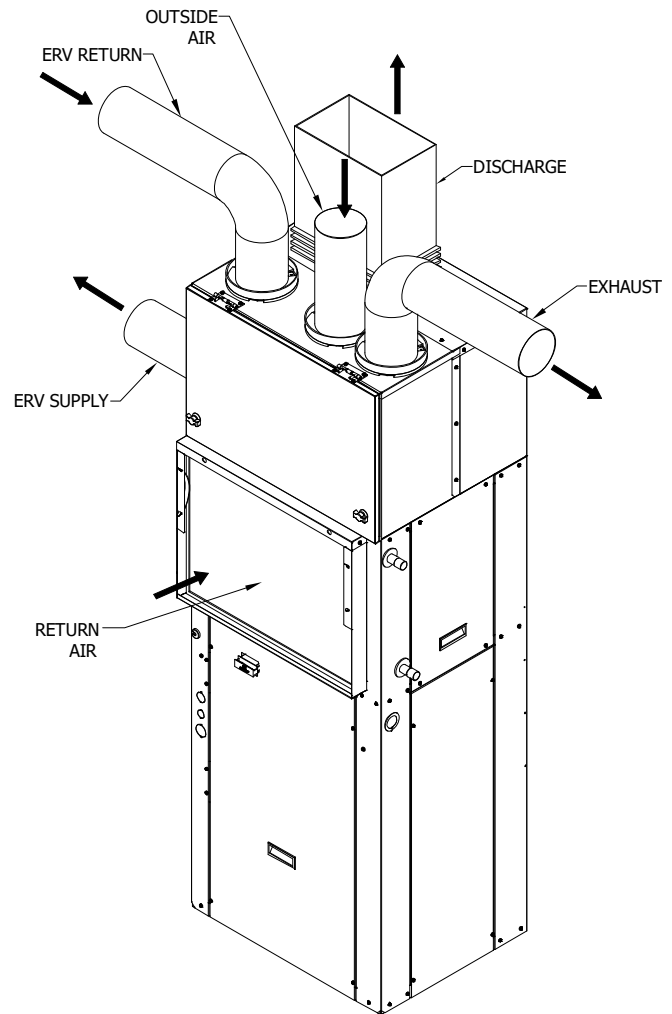

FIGURE 14 - Ductwork

ERV AIR DUCTING

The ERV module requires fresh/exhaust air ducted from/to outside the building and return air ducted from the occupied space. The ERV supply can be discharged into the open return of the closet. If the unit return air is ducted, the ERV supply air must be ducted into the return as well for proper ventilation and filtration.

Examples on ducting the ERV air flow, refer to **FIGURE 15 – ERV AIRFLOW PATHS**

NOTE
Follow the filter rack kit instructions & recommendations for installation.

RETURN AIR DUCTING

Return air duct can be brought in through a wall grille and then to the unit. The return duct system will normally consist of flexible connector at the unit and a trunk duct to the return air grille. With metal duct material, the return air duct should be internally lined with acoustic insulation for sound attenuation. A 2 in. [5.08 cm] air duct collar flange is included on the filter rack for ducted return air application. A flexible duct collar can then be attached between a duct transition and the return air ductwork. The return air duct transition must be the same size as the return air coil face area. See **FIGURE 14 - Ductwork**. Be sure to allow for proper clearance to allow for filter change outs.

NOTE
The Fresh Pak wall sleeve with integrated ventilation air intake and exhaust ports ensures a minimum of 36" of separation between the ventilation air intake and exhaust discharge.

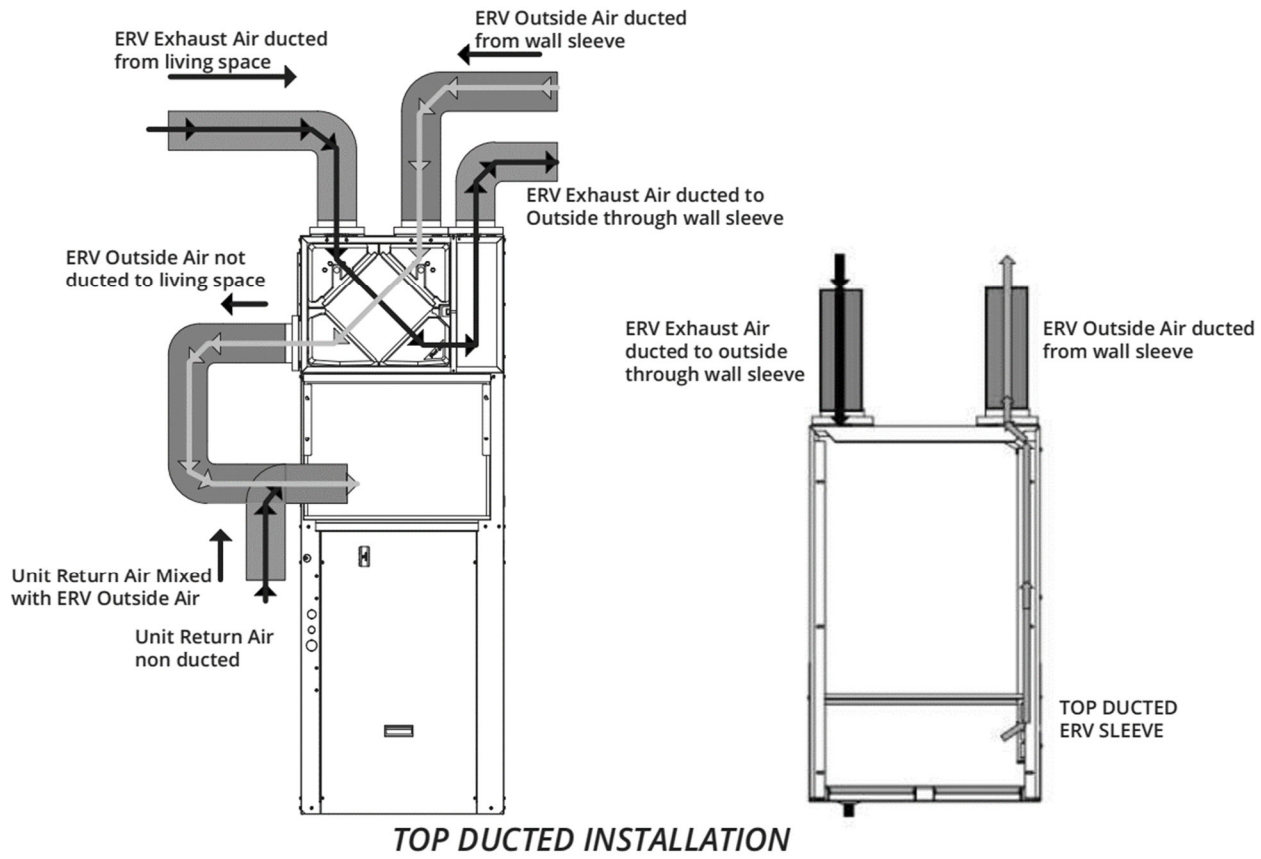

FIGURE 15-ERV AIRFLOW PATHS

INSTALLATION (continued)

CONDENSATE DRAIN

The FRESH-PAK is designed so that the wall sleeve is the principle drain pan. Drain tubing is factory installed which drains evaporator condensate through the bottom of the unit which then is allowed to drain into the wall sleeve pan.

Condensate drain lines must be installed with adequate slope to ensure positive drainage.

Prior to unit installation ensure that the drain is unobstructed and leak free.

! **CAUTION** !

On units with plastic drain pans, the drain connection must be made hand tight only.

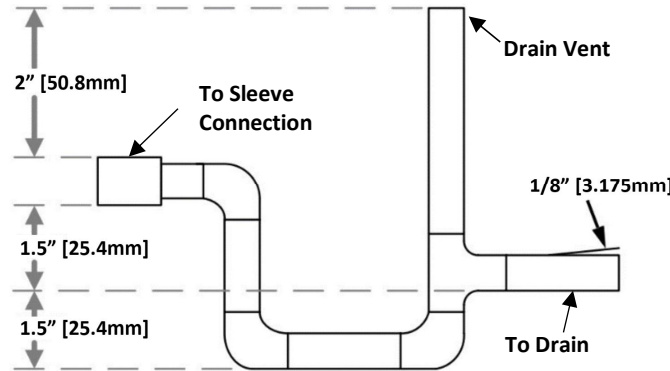

FIGURE 16 - Condensate Drain

i **NOTE** i

While preparing unit for installation, ensure that the drain tubing from the evaporator is securely attached to the copper nipple in the pan under the compressor. The wall sleeve has a 3/4in. NPT nipple located in the bottom for connection to a drain (FIGURE 16 - Condensate Drain). A trap may be required in the condensate drain line to prevent sewer gas from escaping into the room.

Operating Range °F [°C]		
Condition	Cooling	
	Min	Max
Outdoor DB	60 [15.6]	115 [46.1]
Indoor DB	60 [15.6]	90 [32.2]

Table 6 – Unit Operating Range

AIR FILTER

All indoor return air must be filtered. The preferred methods are listed below.

1. Use the factory supplied filter kit which attaches to the inlet of the evaporator.
2. Use the filter kit supplied with the access panel which accepts an 18 in. [45.72 cm] x 20 in. [50.8 cm] x 1 in. [2.54 cm] (or 2 in. [5.08 cm]) throwaway type of filter.
3. Any field installation of an air filter, means must be provided, for use of a disposable filter which is no smaller than the face area of the evaporator coil.

! **CAUTION** !

DO NOT operate this equipment without an air filter.

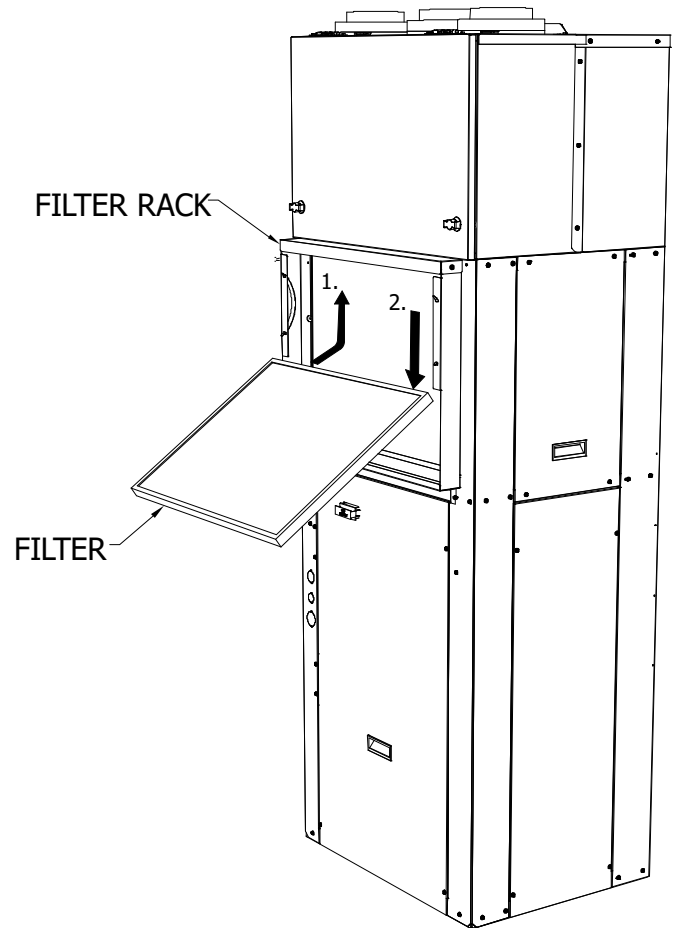

FIGURE 17 - Air Filter

ELECTRICAL

HIGH VOLTAGE

All wiring must comply with local and national code requirements. Units are provided with wiring diagrams and nameplate data to provide information required for necessary field wiring.

! WARNING !

⚡ ELECTRIC SHOCK HAZARD ⚡

Disconnect all power supplies before servicing. Lock out/tag out to prevent accidental electrical shock.

NOTE: There may be multiple power sources supplying the unit.

! WARNING !

Use copper conductors only. Install all parts and panels before operation of unit. Failure to follow these warnings can result in personal injury or death.

Units are provided with a class 2 transformer for 24VAC control circuits. Should any add-on accessory or component also have a class 2 transformer furnished, care must be taken to prevent interconnecting outputs of the two transformers by using a thermostat with isolating contacts.

! WARNING !

Connect ground wire to ground terminal marked "GND". Failure to properly ground the unit may result in personal injury or death.

! CAUTION !

Any device that has been furnished by the factory for field installation must be wired in strict accordance with the associated wiring diagram. Failure to properly wire the unit may damage components and void warranties.

208 VOLT OPERATION

All 208-240 Volt units are factory wired for 240 Volt operation. For 208 Volt operation, moving, changing, or rewiring the line voltage tap on the 24 Volt control transformer is required. See note on unit wiring diagram for instructions.

THERMOSTAT CONNECTIONS KEY		
LETTER	COLOR	DESCRIPTION
C	BROWN	Transformer 24VAC Common
R	RED	Transformer 24VAC Hot
G	GREEN	Evaporator Blower
U	YELLOW	ERV Comfort Common
Y	BLUE	Compressor Contactor
W2	BLACK	Auxiliary Heating

Table 7 - Thermostat Connections Key

LOW VOLTAGE

THERMOSTAT

A 24 VAC Ventilation thermostat is required to operate the FRESH-PAK unit (**FIGURE 18 - Ventilation Thermostat Connections**). A minimum 24 VAC Thermostat is required with a fan signal (G) in all operating Modes (**FIGURE 19 - Non-Ventilation Thermostat Connections**). Thermostat connections and functions are as follows:

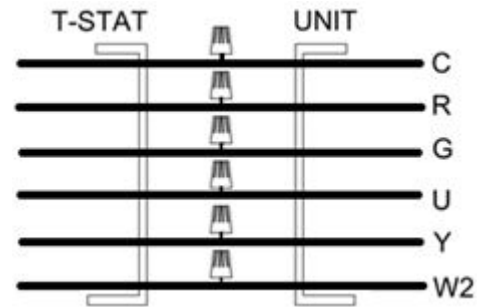

FIGURE 18 - Ventilation Thermostat Connections

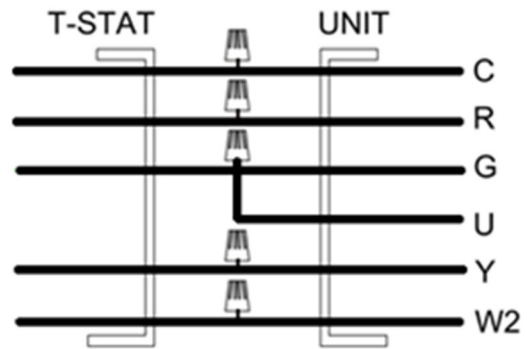

FIGURE 19 - Non-Ventilation Thermostat Connections

THERMOSTAT INSTALLATION

The Thermostat should be located on an interior wall in a larger room, away from supply duct draft. Position the thermostat back plate against the wall so that it appears level and so the thermostat wires protrude through the middle of the back plate mounting holes and drill holes with a 3/16 in. bit. Install supplied anchors and secure plate to the wall. Thermostat wire must be 18 AWC wire.

CONTROLS

ECO SEQUENCE OF OPERATIONS – COOL MODE

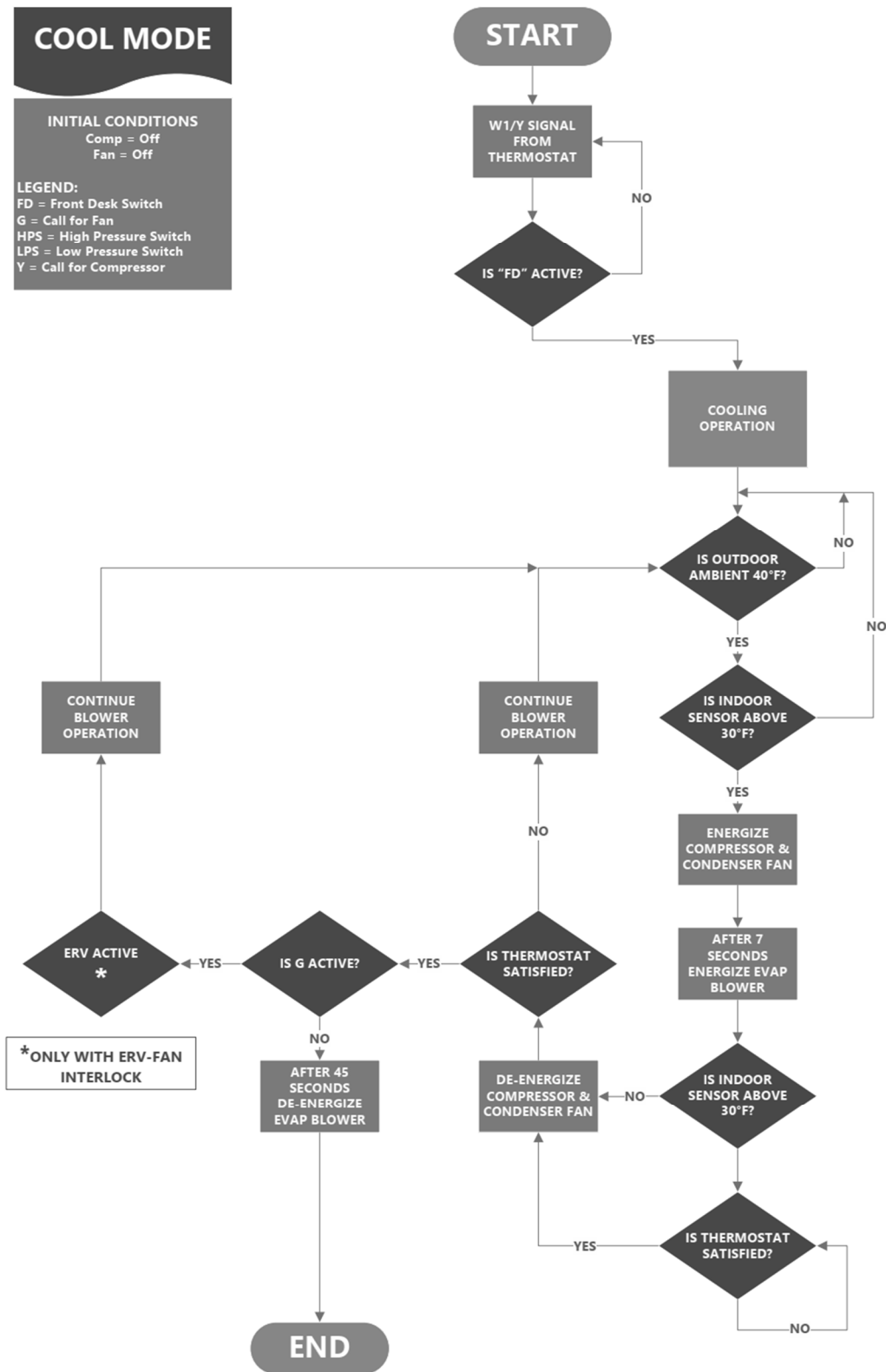

FIGURE 20 - ECO Sequence of Operations - Cool Mode

CONTROLS (continued)

ECO SERIES CONTROL MODULE

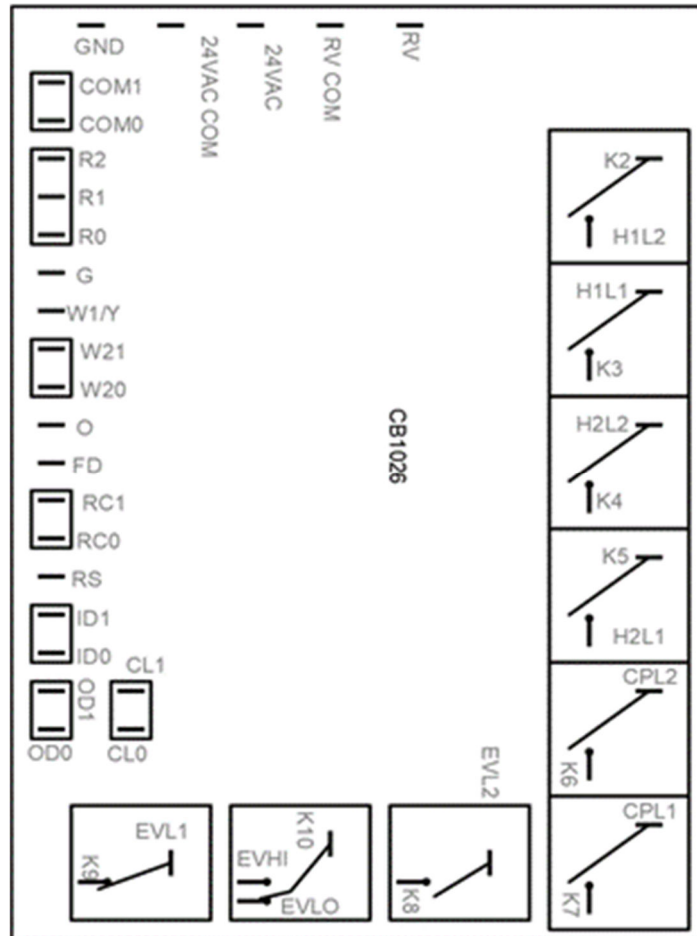

FIGURE 21 - ECO Series Control Module

POWER-UP

When power is first applied to the control, all timers are reset. The control will execute a random start delay before allowing normal operation of outputs, and a compressor anti short cycle delay (6 minute) before allowing the compressor output to be energized. While the control is operating, all of the inputs are continuously monitored for a change in the desired operating status.

RANDOM START DELAY

There will be a control random start delay which will vary from 10 to 60 seconds, which will be executed before energizing outputs when the control is powered up. All control outputs remain off during the random start delay.

ANTI-SHORT CYCLE DELAY

After the compressor output has been energized the control will execute a 6-minute anti short cycle delay from the time the compressor is de-energized, before allowing the compressor output to be energized again. A 6-minute anti short cycle delay will be present at control power up, before allowing the compressor output to be energized.

POWER INTERRUPTIONS

If the power to the control is interrupted for less than 100 milliseconds, the control shall resume operation at the same point in the timing cycle if the compressor output is not energized. Relays may temporarily drop out during the power interruption. Power interruptions greater than 100 milliseconds are to reset the control as a power- sequence. If the power to the control is interrupted for more than 40 milliseconds with the compressor output energized, the compressor output will be de-energized, and the control will execute a short cycle delay before allowing the compressor to operate.

CONTROLS (continued)

COOLING OPERATION

STEADY STATE COOLING

When the “Y” input is present and the compressor is not being held off by the anti-short cycle timer, the control will operate in steady state cooling. In steady state cooling, the compressor and condenser fan are energized. After a 7 second delay the high-speed evaporator fan is energized. If the W2 input is applied to the control, the first stage auxiliary heat output will be energized immediately and the second stage auxiliary heat output will be energized after 15 seconds. The compressor and condenser outputs will be shut off and the evaporator fan will switch to low speed. When the “W2” input is removed, both auxiliary outputs will be turned off immediately, and the control will return to steady state cooling mode, assuming the “Y” input is still present. When the “Y” input is removed, the compressor and condenser fan will be turned off immediately. The high-speed evaporator fan will be turned off following a 45 second blower off delay.

LOW AMBIENT SHUTDOWN

When the control is operating in steady state cooling, and the “INDOOR” input is applied (temperature 30°F [-1°C] and below), the control will immediately de-energize the compressor and condenser fan. The high-speed evaporator will be turned off following a 45 second blower off delay. The compressor will go into an anti-short cycle delay for 6 minutes.

LOW AMBIENT COOLING LOCKOUT

When the control is operating in steady state cooling and the “COOLING LOCKOUT” input is applied (Outside Temperature of 40°F [4.4°C] or less) the control will continue to operate for 10 minutes. After 10 minutes, if the “COOLING LOCKOUT” is still active the cooling operation will be locked out for 30 minutes and run high speed evaporator during the lockout. After 30 minutes the control will be returned to normal operation.

DEFROST LOCKOUT

When the control has inputs for first or second stage heating, and the “OUTDOOR DEFROST” input is removed (switch opens), the compressor and condenser fan outputs are de-energized, and the evaporator fan switches to low speed. If the auxiliary heat outputs are not already active, the first stage of auxiliary heat is energized immediately, and the second stage is energized after 15 seconds.

Any time the “OUTDOOR DEFROST” input is removed (switch opens), a six (6) hour timer is activated and the compressor and condenser fan will not operate until the time has expired. During the time the compressor and condenser fan are locked out, the auxiliary heat will be energized any time there is a “Y” or a “W2” input.



NOTE



Compressor can still run in the cooling mode during the 6-hour lockout.

CONTROLS (continued)

CONTINUOUS FAN OPERATION

If no other thermostat inputs are present, the low-speed evaporator fan output will be energized when the “G” thermostat input is active. If either or both of the “Y” or “W2” inputs are present, the operation of the evaporator fan will be based upon those inputs, and the “G” thermostat input will be ignored. compressor and condenser fan and will only allow auxiliary heat operation. In the case of the “W2” input interrupting the compressor operation, the auxiliary heat will continue to operate until the thermostat is no longer calling for heat.

AUXILIARY HEATING OPERATION

THERMOSTAT CALL FOR AUXILIARY HEAT

If the “W2” thermostat input is present without a “Y” input, the control will operate in the auxiliary heat mode. The low-speed evaporator fan and the first stage auxiliary heat outputs will be energized immediately when the “W2” input is received. After a 15 second staging delay, the second stage auxiliary heat output will be energized. When the “W2” input is removed, all of the outputs will be turned off immediately.

If the “W2” thermostat input is present with a “Y” input, the control will switch the system to auxiliary heat mode and will de-energize the compressor and condenser fan immediately.

LOW ROOM AMBIENT AUXILIARY HEAT

If the “RS” low room temperature input becomes active (switch closes), the control will operate in the auxiliary heat mode, regardless of any other control inputs. The low-speed evaporator fan and the first stage auxiliary heat outputs will be energized immediately when the “RS” input is received. After a 15 second staging delay, the second stage auxiliary heat output will be energized. When the “RS” input is removed, all of the outputs will be turned off immediately.

FRONT DESK SHUTDOWN OPERATION

If the front desk shutdown input “FD” is removed (switch opens), operation based upon the “Y”, “W2” and “G” thermostat input will be prohibited. Auxiliary heat operation based upon the low room ambient temperature input “RS” is the only heating or cooling operation that will be allowed. When the “FD” input is re-applied (switch closes), the control will return to normal operation based upon the thermostat inputs.



NOTE



From the factory this will not shutdown the ERV. This will only shutdown the Heating/Cooling modes.

THERMOSTAT INPUT OPERATION (Y, W2)

If both “Y” and “W2” thermostat inputs are active, the control will lock out or interrupt the operation of the compressor and condenser fan and will only allow auxiliary heat operation. In the case of “W2” input interrupting the compressor operation, the auxiliary heat will continue to operate until the thermostat is no longer calling for heat.

FIELD SPEEDUP MODE

The field speedup mode is entered by applying R (24VAC) to Y (active) without “B” being active (Cooling Mode), and closing the cooling lockout sensor switch (24VAC applied to the terminal). The field speedup mode is automatically canceled after 5 minutes. While in the filed speedup mode, control timings will be reduced as follows:

Random Start Delay	0 Seconds
Short Cycle Delay	5 seconds
Cooling Blower off Delay	0 Seconds
Auxiliary Heat Staging Delay	1 Second

CONTROLS (continued)

ERV CONTROL MODULE

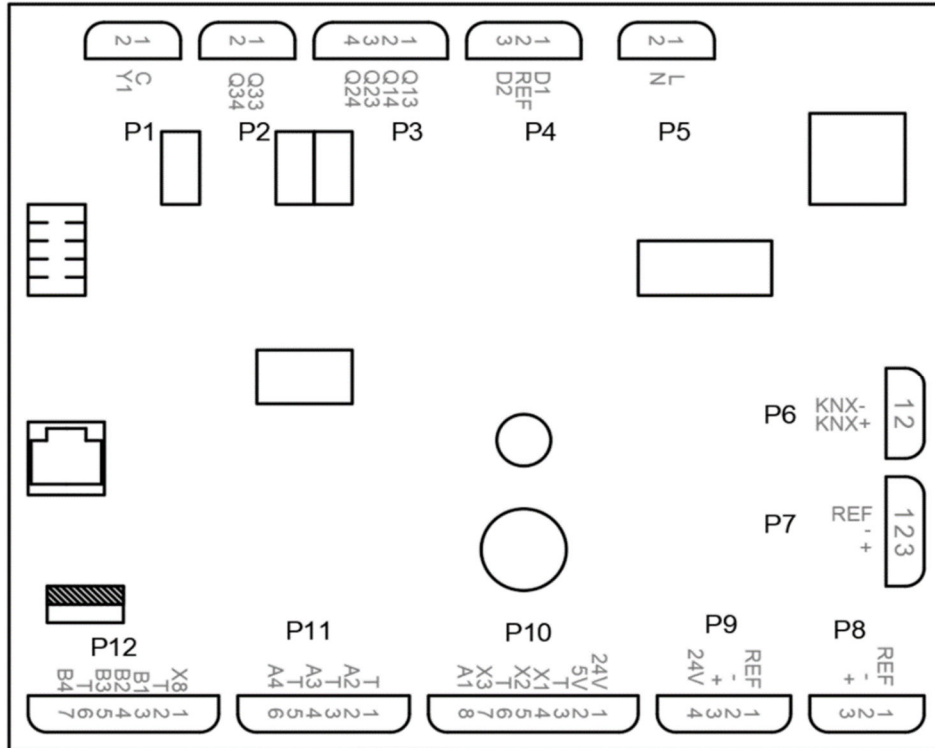

FIGURE 22 - ERV Control Module

ERV CONTROL MODULE KEY		
INTERFACE	TYPE	NOTE
B1, B2, B3, B4	Analog Input 1: Resistor NTC10k	AI
X1, X2	Analog Input 1: Measuring 0---10V 2) Tacho pulse (max. 300Hz)	AI
X3	Analog / Digital (Binary) Input 1: Measuring 0---10V 2: Potential free contact (NO or NC)	AI, BI
A1, A2, A3, A4	Analog Output 1: Signal 0---10V	AO
X8	Analog / Digital (Binary) Input 1: Resistor NTC10K 2: Potential free contact (NO or NC)	AI, BI
D1, D2	Digital (Binary) input 1: Potential free contact (NO or NC)	BI
Q1, Q2, Q3	Relay (Binary) Output 1: Potential free contact (NO)	BO
Y1	Digital (Binary) / Analog Output triac VAC 1: Signal On/Off 2: Signal PWN (constant period)	BO, AO

Table 8 - ERV Control MODULE KEY

i

NOTE

TO MAKE ERV CONTROL CHANGES:

CONNECT EITHER OPTIONAL WIFI KIT OR BACNET COMMUNICATION TO THE ERV.

i

CONTROLS (continued)

ERV DEFAULT CONFIGURATION

The controller's I/O are preconfigured for the following applications:

- Supply exhaust fan speed control
- Outside air damper control (on off)
- Contact input for rapid ventilation (Fan boost) and occupied operating mode
- Common alarm output

DEFAULT ERV CONFIGURATION				
PIN	DESCRIPTION	BACNET OBJECT	SIGNAL TYPE	NOTE
B1	Outside air temperature	TOa	NTC10k	
B2	Supply air temperature	TSu	NTC10k	
B3	Exhaust air temperature	TEh	NTC10k	
B4	Extract air temperature	TEx	NTC10k	
D1	Rapid ventilation input	RpdVntIn	Contact	NO
D2	Input room operating mode Comfort	OpModRin	Contact	NO
X1	Supply air fan speed feedback pulse	FanSuSpdFb	0---30 Hz	
X2	Exhaust air fan speed feedback pulse	FanEhSpdFb	0---30 Hz	
X3*	None	-	-	
X8*	None	-	-	
Q1*	None	-	-	
Q2	None	-	-	
Q3	Outside air damper command	DmpOaCmd	Relay	
A1	Supply air fan speed	FanSuSpd	0---10V	
A2	Exhaust air fan speed	FanEhSpd	0---10V	
A3	Mixing air damper position	MADmpPos	0---10V	
A4	Outside air damper position	OADmpPos	0---10V	
Y1	None	-	-	
*Not active from the factory will require field configuration				

Table 9 - Default ERV Configuration

ERV Modes of Operation				
OPERATING MODE	CATEGORY	OPERATING VIA	DURATION	ACTIVATION SIGNAL
Protection	Off mode	APP, DI	Permanent	
Unoccupied	Normal or away mode	APP, POS8, DI	Permanent or TSP	
Economy	Normal mode	APP, POS8, DI	Permanent or TSP	
Comfort	Normal or Home mode	APP, POS8, DI	Permanent or TSP	
Fan boost (Rapid ventilation)	Temporary mode	APP, POS8, DI	Temporary	Continuous or pulse signal (Duration can be parameterized)

Table 10 - ERV Modes of Operation

CONTROLS (continued)

ERV DEFAULT CONFIGURATION

OPERATING MODE CATEGORIES

The following selectable operating modes belong to operating mode categories.

NORMAL MODES

The normal modes Unoccupied, Economy, and Comfort are the main operating modes that can be applied for a constant and, if desired, infinite time. For each one, certain settings are defined, which sensibly apply to the corresponding state of the system.

- **Unoccupied** - the building is unoccupied and the system is operated with the most essential settings needed.
- **Economy** - The building is occupied, but the system is operated with economical, energy efficient settings
- **Comfort** - The building is occupied and the system is operated according to the needs of the user.

TEMPORARY MODES

The modes Fan Boost, is a temporary mode that can only be activated for a certain, settable time. The temporary mode is activated either via POS8.44X0 or configured digital input as an impulse button or, when pressed longer, as an “egg timer”.

Once activated, they override all normal operating mode and for the set time, the dedicated settings for the temporary mode apply, which mostly concerns the fan speed.

SIGNAL FOR FAN BOOST

If the duration of the signal is <5 seconds:

- The Signal is interpreted as an impulse: The temporary mode is started and only stopped when the timer has expired.

If the duration of the signal is >5 seconds:

- The signal is interpreted as an “egg timer”: Temporary modes is started when the signal is activated and stopped when the signal is inactive.

OFF MODE

The operating mode Protection switches the system into a form of “Off” mode in which the fans no longer run. However, the system is not switched off completely, individual pumps can continue to operate and the frost protection strategy continues to run for as long as has been set. The Protection mode can only be set in the configuration and cannot be set by the end user themselves (neither via app nor POS8.44x0).

OPERATING MODE SETTING

The settings for the operating modes define the specific settings for the supply and exhaust fans for all operating modes and for the speed and flow control strategies. These settings are configured by the installer. The end user has no option to change the values for the operating modes.

For Comfort, Economy, and Unoccupied modes, dedicated settings for temperature can be defined. The temporary operating modes Fan Boost, In-room-sensor, have no dedicated temperature settings. For these modes, the settings of Comfort mode apply.

FAN SPEED CONTROL

Supply fan and exhaust fan set points have defined setting for each operating mode level. Individual percentage value is used between 0---100%. These settings only define the fan speed used in various operating modes and they have no effect on other functions like de-icing.

During active temperature control, values set here are used as maximum speed (80%). Depending on deviations to set point, temperature control can freely increase/decrease the speed of both fans simultaneously with symmetrical control signal which then keeps the set supply/exhaust ratio in every situation.

FAN BOOST

The Fan Boost mode can be activated as a temporary mode to temporarily increase ventilation, e.g., after a bath or in a sauna. In this case, Fan boost is activated directly and kept active until the set time has elapsed. The Fan boost mode uses the fan speeds defined for the Comfort operating mode.

PASSIVE HEAT EXCHANGER, UNCONTROLLED (PLTHEXG22Y)

The purpose of energy recovery is to absorb heat/cold from the exhaust air and transfer it back to the supply air side. The control of the energy recovery is not possible, the ERC always works with maximum capacity. With this solution, the outside air cannot be used for heating or cooling even if the outside air is closer to the set point than the exhaust air (e.g., in rooms with a high internal load or when heating up after cold nights.)

CONTROLS (continued)

C DE-ICING (PASSIVE, UNCONTROLLED)

Passive Energy Recovery units are basically just heat exchangers. They receive warm and humid air on one side and cold on the other which will eventually cumulate ice on the surfaces when the conditions are suitable for that. Passive element usually starts to cumulate ice close to 32° F [0° C].

ERV DEFAULT CONFIGURATION

DETECTING ICE ON THE HEAT EXCHANGER OR IN THE DUCT WORK

Detecting ice on the heat exchanger or in the ductwork is possible.

- With exhaust air temperature sensor TE_h . This is not a real indication, but an expectation that ice is expected to build up.
 - Deicing with TE_h sensor starts with TE_h is below the limit.
 - The end of the de-icing phase cannot be detected and is estimated via timer.
- With outside air sensor TO_a . This is used when no exhaust air sensors are available. It is also only an expectation that ice has built up.
 - De-icing with TO_a sensor starts when the TO_a is below the limit.
 - The end of the de-icing phase cannot be detected as is estimated via timer.

DE-ICING THE HEAT EXCHANGER

De-icing is possible by:

- Reducing the supply fan speed, so that the load of cold air incoming is reduced, increasing the exhaust air temperature.
- Preheating the outside air, increasing the exhaust air temperature.

DE-ICING MODES

The de-icing mode can be configured as:

- No De-icing
- Reduce fan speed
- Increase preheating
- Reduce fan speed and increase preheating

Deicing with fan speed is running in parallel or with 2-stage, see below.

TIME BASED DE-ICING STARTED BY TE_h OR TO_a

The sensor is not suitable for detecting the end of the de-icing phase. Therefore, a fixed de-icing time is used. After de-icing is finished, an off time is started until the next de-icing phase can be started again. The duration of the off time depends on the measured temperature at the start of the de-icing phase. De-icing time, maximum

off time with assigned temperature and minimum off time with assigned temperature can be configured.

DE-ICING WITH REDUCED FAN SPEED STARTED BY TE_h OR TO_a

The temperatures have 2 adjustable limits. The limit SpTDeicFan (stage 2) starts de-icing with the fan speed. During deicing, fan speed for supply fan and exhaust fan are reduced to configurable values. For faster de-icing, it is possible to set supply fan speed set point even to 0%. In this case electric heaters in the supply air are blocked.

ERC SUPERVISION (PASSIVE, UNCONTROLLED)

A mechanical failure on the ERV (heat exchanger dirty etc.) can be detected via the efficiency of the heat exchanger. Therefore, the temperature difference between extract air / room air and exhaust air is used. When the difference drops below set value and stays below during set delay time, alarm is generated. Detection function is active only when temperature difference between outside air and extract air is more than set limit. When extract air temperature and exhaust air temperature are not available, the supervision of the ERV is not possible.

PRIORITY LIST

Different functions require priorities over the other functions so that logical/critical operation can be guaranteed.

- Safety functions (field configured)
 - Off by smoke detector, emergency, supply air temperature or extract air temperature
 - Off by fire damper closed
 - Purge or smoke extract by smoke detector
- Protection functions
 - A-Alarms for plant protection
 - ERC de-icing function
- Switch or push-button operations
 - Rapid ventilation mode (Configured B1, POS8)
 - Comfort mode (Conf. B1), Fireplace (Conf. B1), Off mode (Conf. B1), Eco mode (Conf. B1)
 - Maintenance function
- User operation
 - Present / Away button
 - Manual operation
- Automatic Function
 - Scheduler operation mode

CONTROLS (continued)

ERV DEFAULT CONFIGURATION

OUTSIDE AIR DAMPERS (DMPSHOFFOA11Y)

When ventilation is active the outside air dampers are always open. Damper(s) are controlled open/close from one binary output. Delay time for outside air damper opening can be defined to secure that damper is fully open before fans are started.

STARTUP / SHUT-DOWN SEQUENCE

For safe and optimum operation of the ventilation unit, special switch-on and switch-off sequences are used to switch the ventilation off and on again. The ventilation unit is normally not “switched off”, but can be switched off for maintenance work or in emergency situations. This can be done by opening the ERV maintenance panel releasing the door switch signal or by powering down whole FRESH-PAK system. The start –up sequence is used every time except in emergency situations. The start-up sequence applies also for fire damper test function which is performed automatically.

STARTUP SEQUENCES

1. Start is initiated.
2. Only after power return. Delay time step 2 (to secure startup time for valves, fire dampers and ERC)
3. If available open the outside air dampers. Delay time step 3 (to secure dampers fully open). If damper output cannot be switched, an A-Alarm is activated, the startup process is stopped.
4. ERC ramps up to maximum speed. Heat exchangers bypass closes. Exhaust fan starts and ramps up to comfort mode speed. If exhaust fan speed is monitored, and the feedback signals is not received within the delay time, an A-Alarm is activated, the starting process is stopped. Delay time step 5 (to secure “heating up” of heat exchanger)
5. Supply fan starts and ramps up to “unoccupied” mode speed Delay time step 6. If supply fan speed is monitored, and the feedback signal is not received within the delay time, and A-Alarm is activated, the starting process is stopped.
6. Both fans ramp to required operating mode speed. Delay time step 6 preparing for normal operation.
7. Normal operating mode is started.

SHUTDOWN SEQUENCES

Executed after normal operation or if startup is interrupted after step 4 is finished. Shutdown sequence is not used in emergency situations.

1. Shutdown is initiated.
2. Both fans ramp down to stop.
3. Close the outside air dampers, same time as in start-up step 5.
4. Plant is “Off”.



NOTE



The ERV portion of the FRESH-PAK can be switched off using the BACnet. The stop sequence is executed by activating the input PrtOpModRIn or the BACnet object PitShD. These functions override all other influences except the emergency control and protection control.

ERV ALARM FUNCTIONS

GENERAL

The application uses 2 different alarm classes:

An **A-Alarm** indicated as important and urgent situation. IF an A-Alarm is triggered, the unit shuts down. An **A-Alarm** must be acknowledged and can only be reset after cause of alarm is eliminated.

A **B-Alarm** indicates a less urgent maintenance incident and during active B-Alarm, the unit runs either normally or is still in acceptable conditions to run (without major problems).

The installer can configure alarm for certain errors and can chose between A-Alarm, B-Alarm or no alarm. Alarms must be acknowledged and as soon as the cause for each alarm is eliminated, normal operation is resumed. If one or more reasons still exist, acknowledgement does not rest that specific alarm and operation might not continue normally. All alarms are shown with a time stamp and entry to nonvolatile storage for each “change of state”. Five different alarm state are used in the application and they are valid for both A and B-alarms. These different states are meant to give additional information for different users and different situations. Relay operation is depending on actual configuration.



NOTE



See Troubleshooting section for additional alarm details.

For more information on ERV Alarm Function please see the **TROUBLESHOOTING** Section.

CONTROLS (continued)

BLOWER SPEED CONTROL

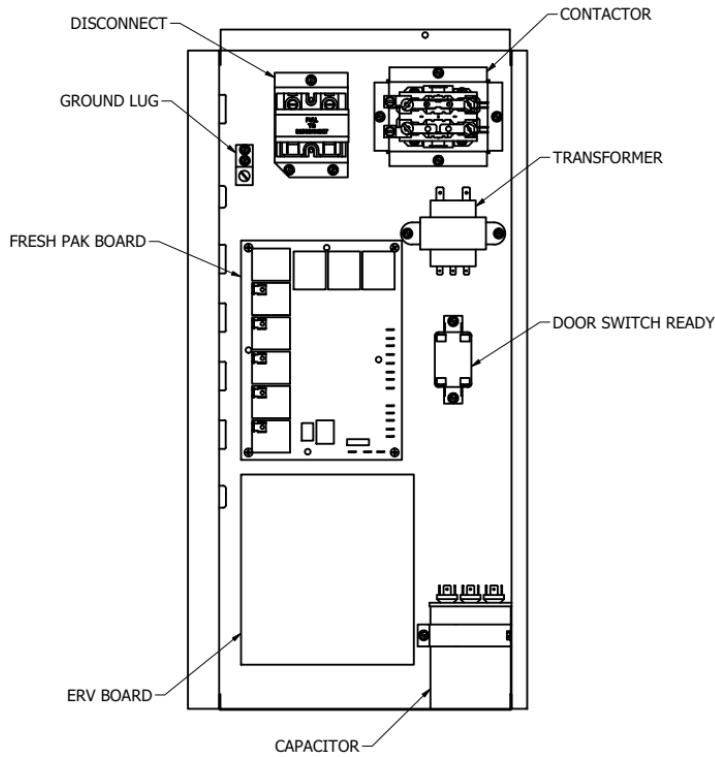

FIGURE 23 - Controls Box Detail

FRESH-PAK units are equipped with a direct drive ECM blower motor. See the **BLOWER DATA** section for airflow at different external static pressure. Select the motor speed according to the airflow and external static pressure. See wiring diagram located on unit.

For FRESH-PAK models, the default motor tap selections can be changed by directly changing the speed tap at the motor terminal.

⚠	WARNING	⚠
⚡	ELECTRIC SHOCK HAZARD	⚡
<p>High efficiency brushless DC motors are wired with power applied at all times, see illustration above. Low voltage thermostat demand and board algorithms will control its use.</p>		

BLOWER DATA

EFE BLOWER DATA									
MODEL NUMBER	Motor Speed Tap	CFM vs EXTERNAL STATIC PRESSURE (IWC)							
		0.05	0.1	0.15	0.2	0.25	0.3	0.35	0.4
EFE09	T1	330	330	320	320	310	300	300	290
	T2 (H & C)	400	400	390	380	380	370	370	360
	T3	490	490	480	480	470	460	460	450
EFE12	T1	360	360	350	340	340	330	330	320
	T2 (H & C)	440	430	430	420	420	410	400	390
	T3	510	510	500	490	490	480	470	470
EFE18	T1	570	560	550	540	520	500	490	470
	T2 (H & C)	660	650	640	620	610	590	580	560
	T3	710	700	690	680	660	650	630	620
	T4	730	720	710	690	680	660	650	630
	T5	760	760	750	730	720	700	680	670
EFE24	T1	730	720	710	690	680	660	650	630
	T2 (H & C)	830	820	810	800	780	770	750	740
	T3	910	900	890	880	860	850	830	820
	T4	940	940	930	910	900	880	870	850
	T5	1010	1000	990	970	960	940	930	910
EFF30	T1	860	850	840	840	830	820	810	800
	T2 (H & C)	940	940	930	920	920	910	900	880
	T3	1070	1060	1060	1050	1040	1030	1020	1010
	T4	1170	1160	1160	1150	1140	1130	1120	1110
	T5	1290	1290	1280	1270	1260	1260	1250	1230
Airflow data shown is with a dry coil at 70°F DB EAT and with standard 1" filter.									
(1) Factory Settings: (H) Heating, (C) = Cooling									
Table 11 - FRESH-PAK Blower Data (1)									

BLOWER DATA (continued)

EFW BLOWER DATA									
MODEL NUMBER	Motor Speed Tap	CFM vs EXTERNAL STATIC PRESSURE (IWC)							
		0.05	0.1	0.15	0.2	0.25	0.3	0.35	0.4
EFW09	T1	330	330	320	320	310	300	300	290
	T2 (H & C)	360	360	350	340	340	330	330	320
	T3	400	400	390	380	380	370	370	360
EFW12	T1	410	410	400	390	390	380	370	370
	T2 (H & C)	410	410	400	390	390	380	370	370
	T3	490	490	480	480	470	460	460	450
EFW18	T1	640	610	590	570	560	550	540	530
	T2 (H & C)	640	610	590	570	560	550	540	530
	T3	710	680	660	650	640	630	620	610
	T4	740	710	690	680	670	660	650	640
	T5	800	780	760	740	730	720	710	700
EFW24	T1	830	800	780	770	760	750	740	730
	T2 (H & C)	830	800	780	770	760	750	740	730
	T3	920	890	870	860	850	840	830	820
	T4	970	940	920	910	900	890	880	870
	T5	1020	990	970	960	950	940	930	920
EFW30	T1	930	900	880	870	860	850	840	830
	T2 (H & C)	990	960	940	930	920	910	900	890
	T3	1130	1100	1080	1070	1060	1050	1040	1030
	T4	1160	1130	1110	1100	1080	1080	1070	1050
	T5	1200	1170	1150	1130	1120	1110	1100	1090
Airflow data shown is with a dry coil at 70°F DB EAT and with standard 1" filter.									
(1) Factory Settings: (H) Heating, (C) = Cooling									
Table 12 - FRESH-PAK Blower Data (2)									

FIELD ERV ACCESSORIES

FIELD ERV ACCESSORIES CONNECTIONS

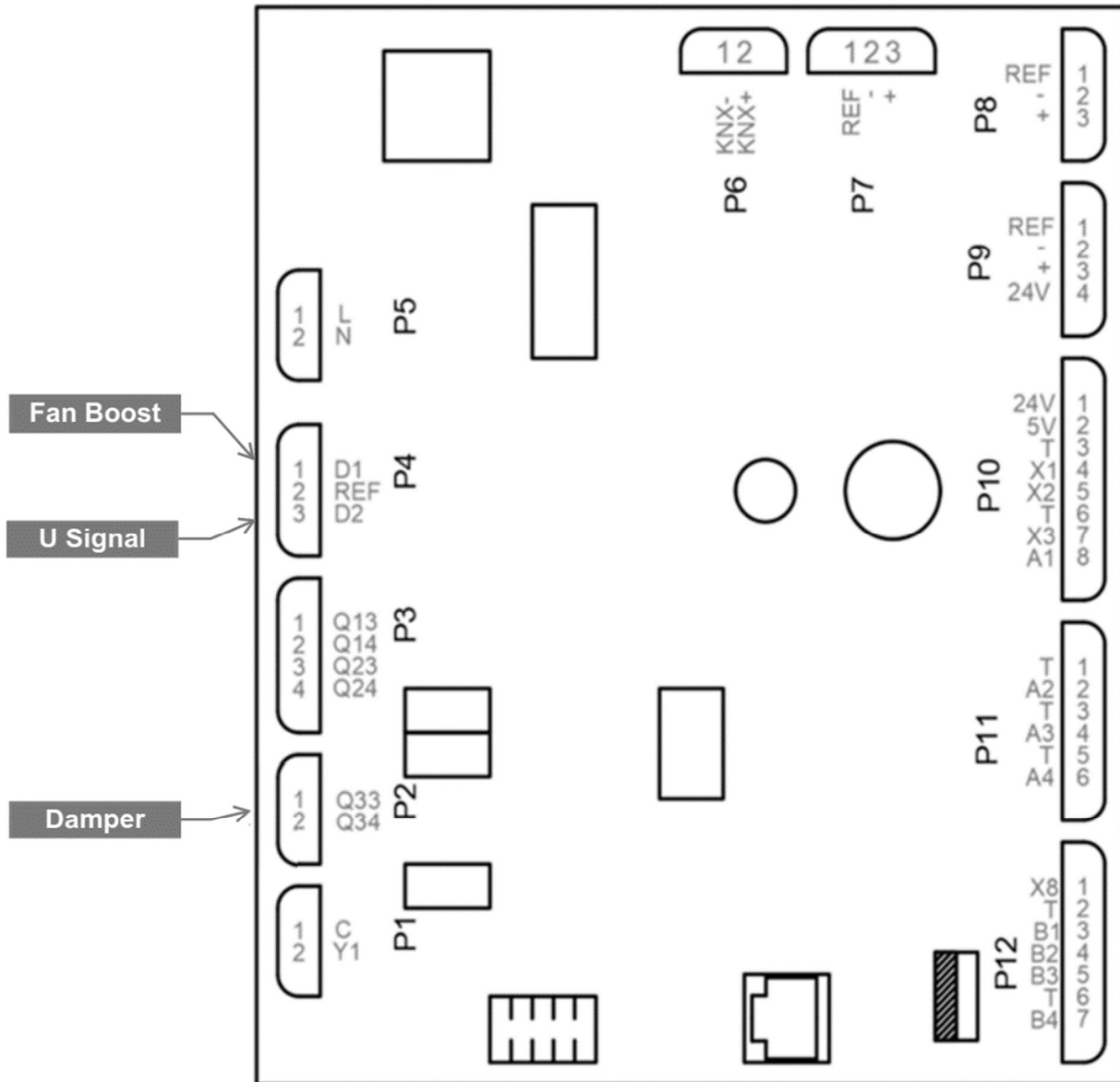

FIGURE 24 - Field ERV Accessories Connections

FIELD ERV ACCESSORIES

INSTALLATION

IMPORTANT

Installation must be Manufacturer Approved.

OUTSIDE AIR DAMPER

The FRESH-PAK ERV control allows for the addition of a motorized outside air damper. This is to help prevent any back draft air from entering the space while the ERV is not operating.

NOTE

Damper must be 24V and normally closed.

1. Power down FRESH-PAK unit.
2. Attach 24V lead to Q3 (See **FIGURE 25 - Outside Air Damper Connection**) on the ERV control board.
3. Connect the Com lead of the damper to a chassis ground of the FRESH-PAK unit.
4. Power on the FRESH-PAK unit.
5. Once the ERV restarts (about 1-2 minute delay), verify that the damper opens.

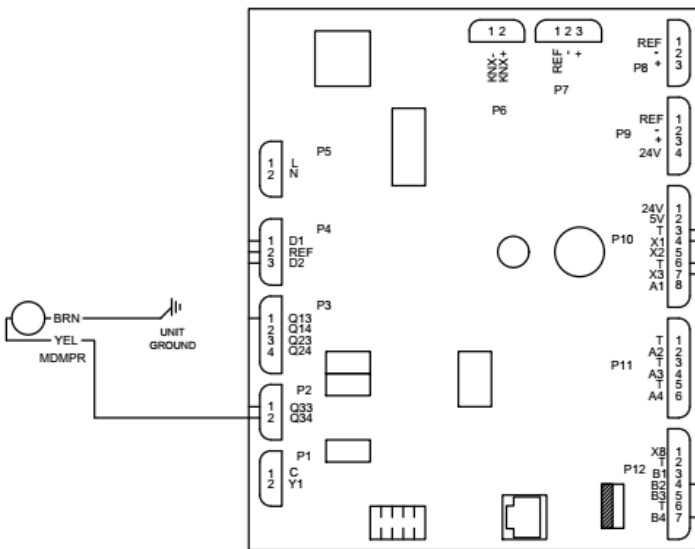

FIGURE 25 - Outside Air Damper Connection

BOOST TIMER

The FRESH-PAK ERV controller has the flexibility to work with many different wall mounted boost timers (egg timer). For typical analog (rotary style) timers follow Version 1 installation method. For digital (120V wall style) follow Version 2 installation.

VERSION 1 (ANALOG)

1. Power down FRESH-PAK unit.
2. Find the 120V relay in the FRESH-PAK control box. Refer to the applicable wiring diagram. Remove the 24V leads from the relay.
3. Connect the transformer side 24V lead to the LINE side of your timer switch.
4. Connect the LOAD side of the timer switch to the D1 terminal wire [See **FIGURE 26 - Version 1 (Egg Timer/Analog Connection)**].
5. Reenergize the FRESH-PAK unit.
6. Once the ERV restarts (about 1-2 minutes) activate the timer and confirm the ERV fans go to high speed "Comfort Mode".

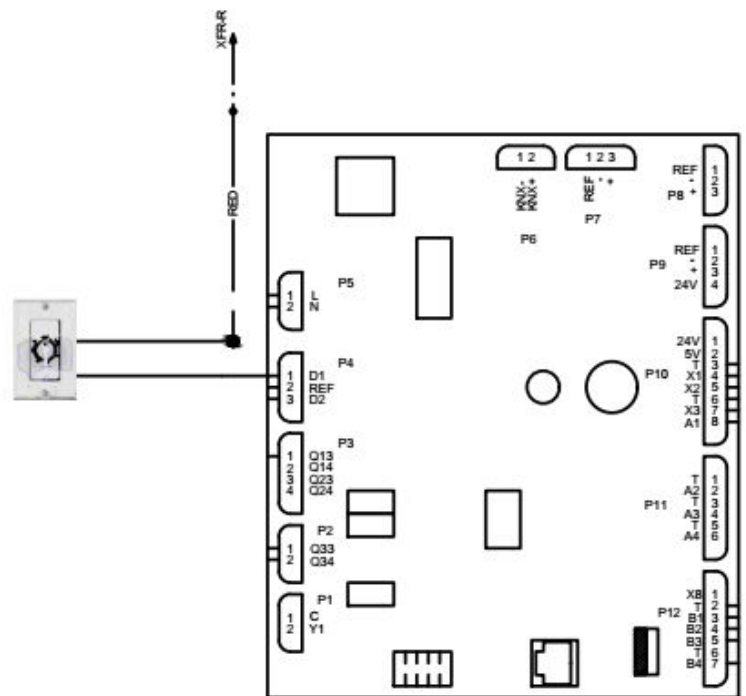

FIGURE 26 - Version 1 (Egg Timer/Analog Connection)

FIELD ERV ACCESSORIES (continued)

VERSION 2 (DIGITAL)

1. Power down FRESH-PAK unit.
2. Refer to the Installation instructions provided with the 120V digital timer switch. The switch will require its own 120v power source.
3. Find the 120V relay in the FRESH-PAK control box. Refer to the applicable wiring diagram.
4. Connect the R connection of the timer switch to the 120V pole on the relay.
5. Connect the NEUTRAL side of the timer switch to the remaining pole on the 120V relay (
6. **FIGURE 27 - Version 2 (120V Digital Timer Connection)**).
7. Reenergize the FRESH-PAK unit.
8. Once the ERV restarts (about 1-2 minutes) activate the timer and confirm the ERV fans go

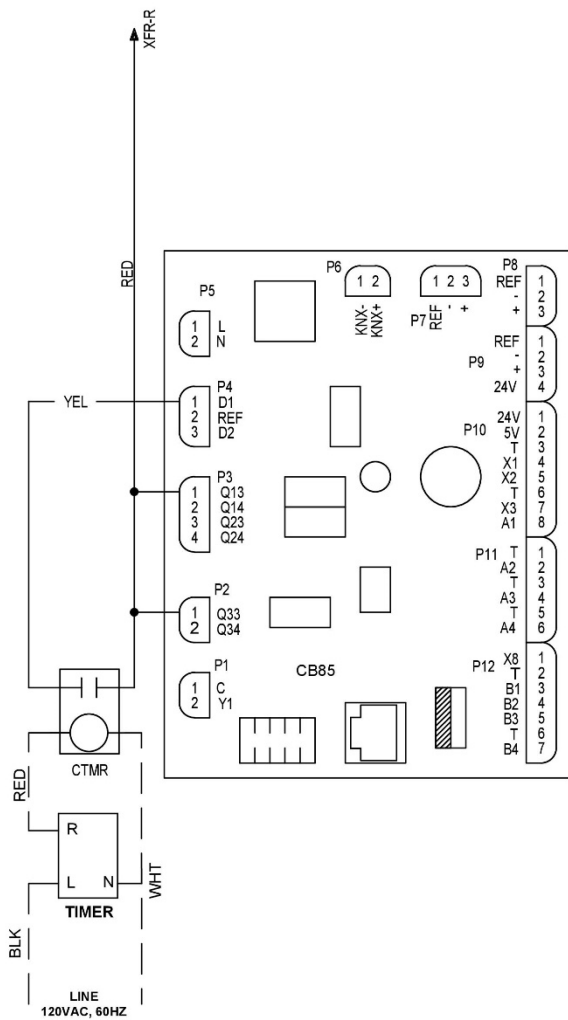

FIGURE 27 - Version 2 (120V Digital Timer Connection)

CO2/Humidity Sensor

1. Power down FRESH-PAK unit.
2. Refer to the Installation instructions provided with the 24V Sensor.
3. For sensors with 0-10V PWM fan control use connection A shown in **Figure 29 – Humidity/CO2 Sensor**. For 24V relay activation of fans use the B connections. Insert sensor wires into specified terminals. **DO NOT REMOVE ANY EXISTING WIRES FROM ERV CONTROLLER**
4. Connect the 24V power for the sensor to the R terminal and the 24V Common to the C terminal of the thermostat
5. Reenergize the FRESH-PAK unit.
6. Once the ERV restarts (about 1-2 minutes) Test the sensor to ensure fan operation.

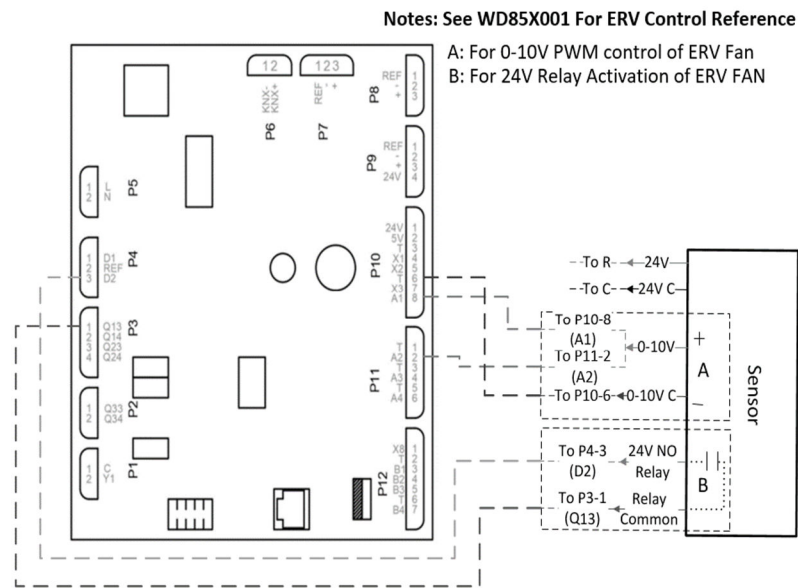

Figure 28 – Humidity/CO2 Sensor

LOCATION OF MAJOR COMPONENTS

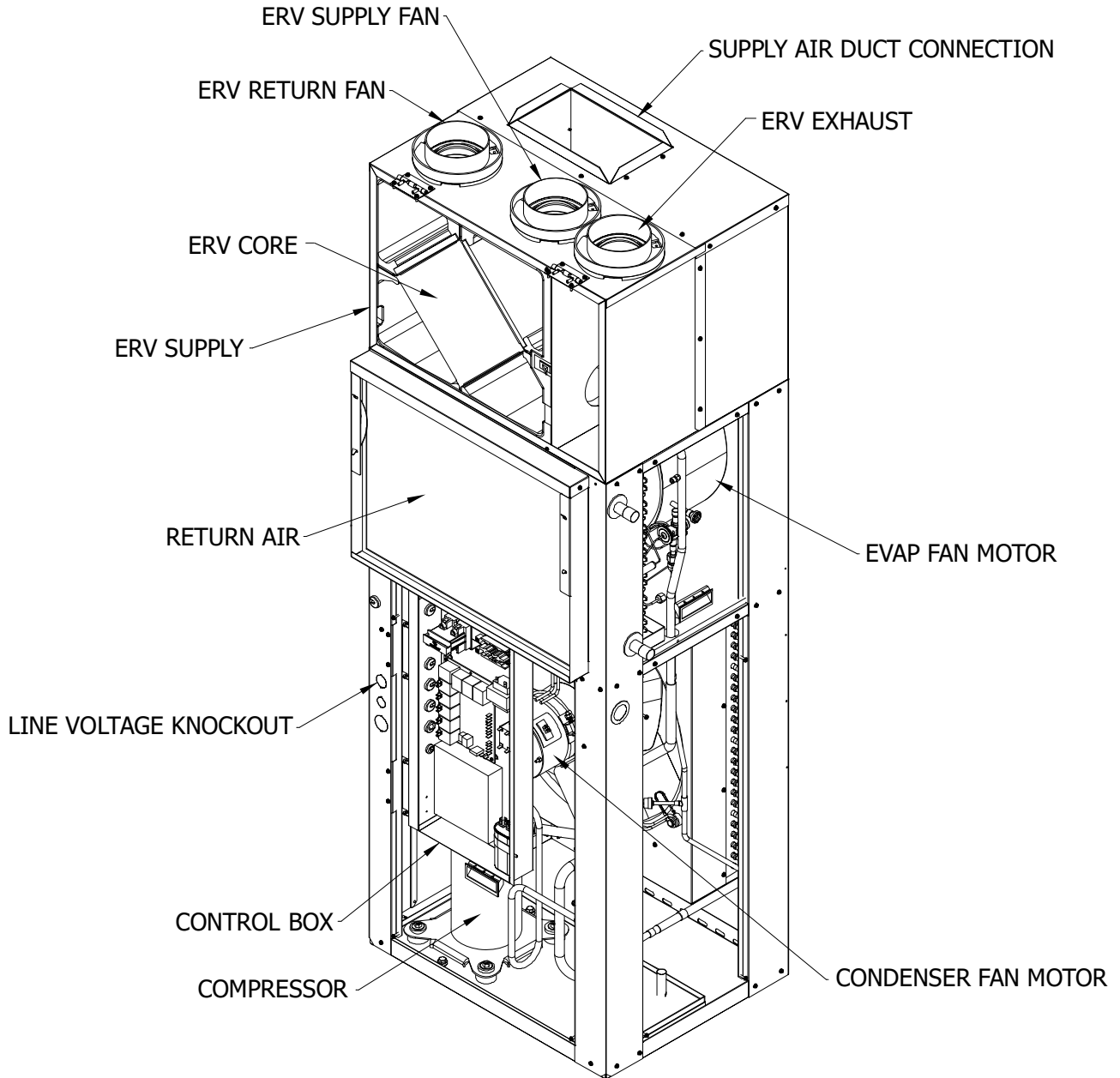

FIGURE 29 - Location of Major Components

WIRING DIAGRAMS

WD85X001 ERV WIRING DIAGRAM

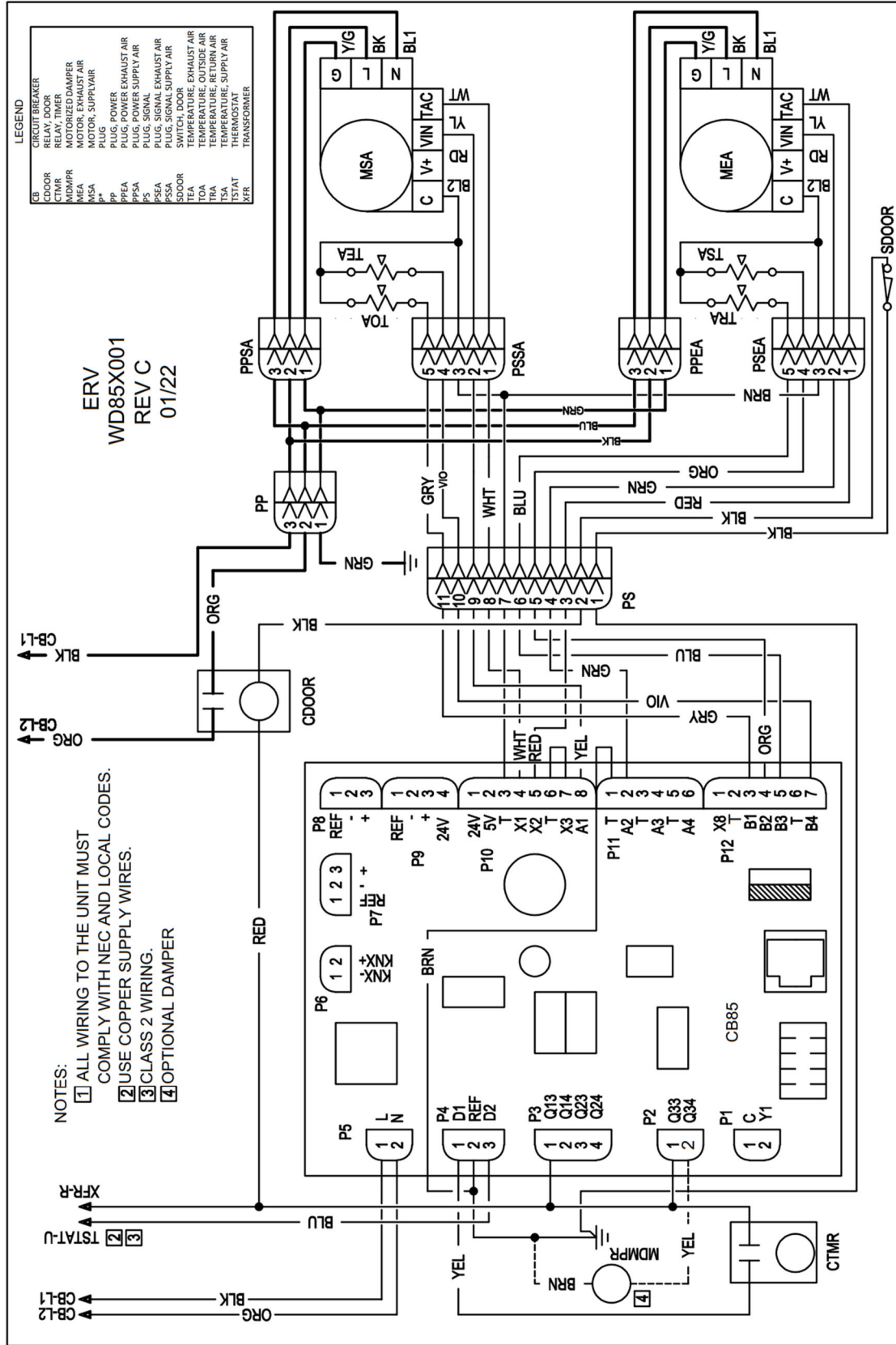

FIGURE 30 – WD85X001 ERV Wire Diagram

WIRING DIAGRAMS (continued)

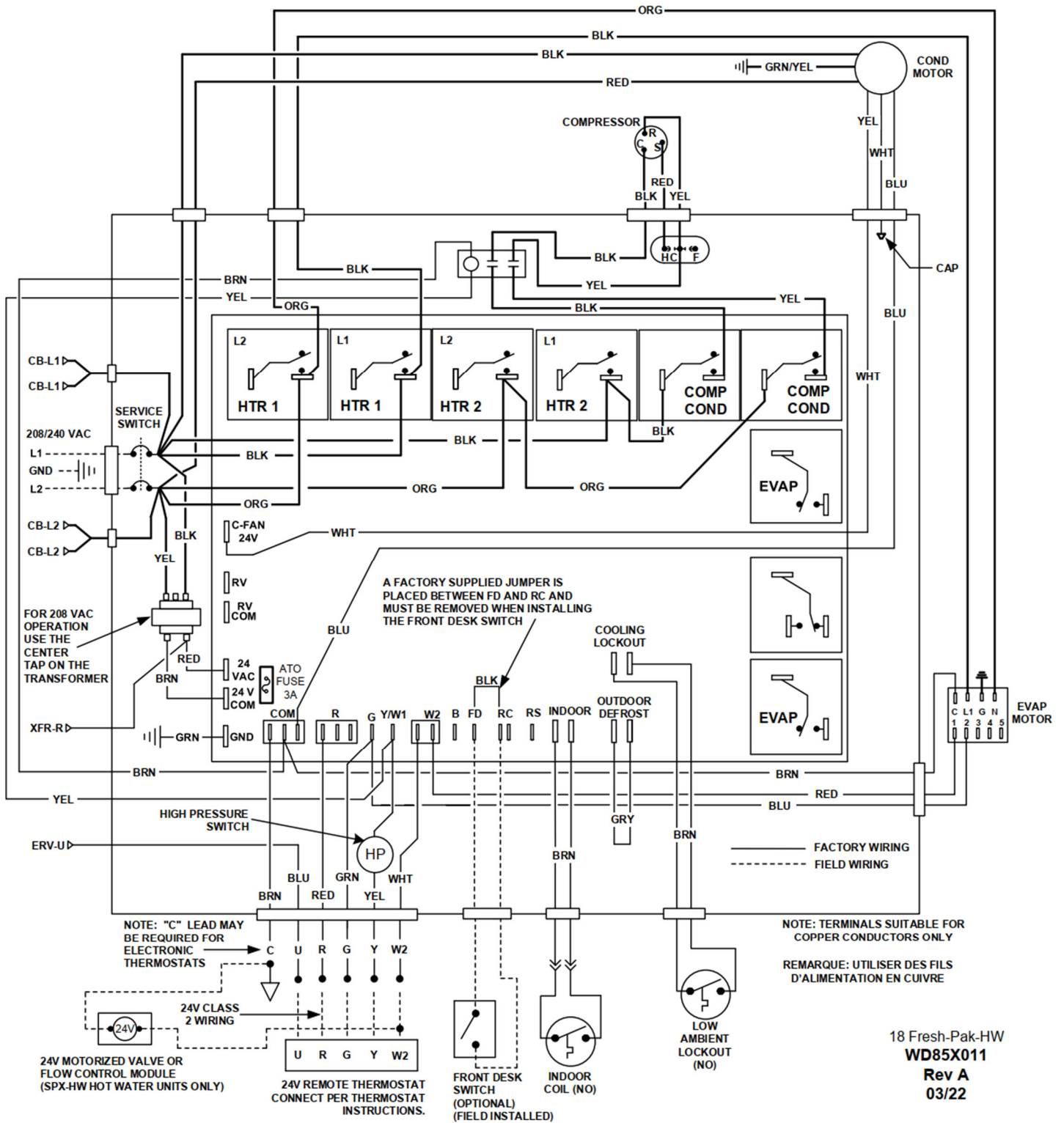

FIGURE 33 - WD85X011 Wiring Diagram

WIRING DIAGRAMS (continued)

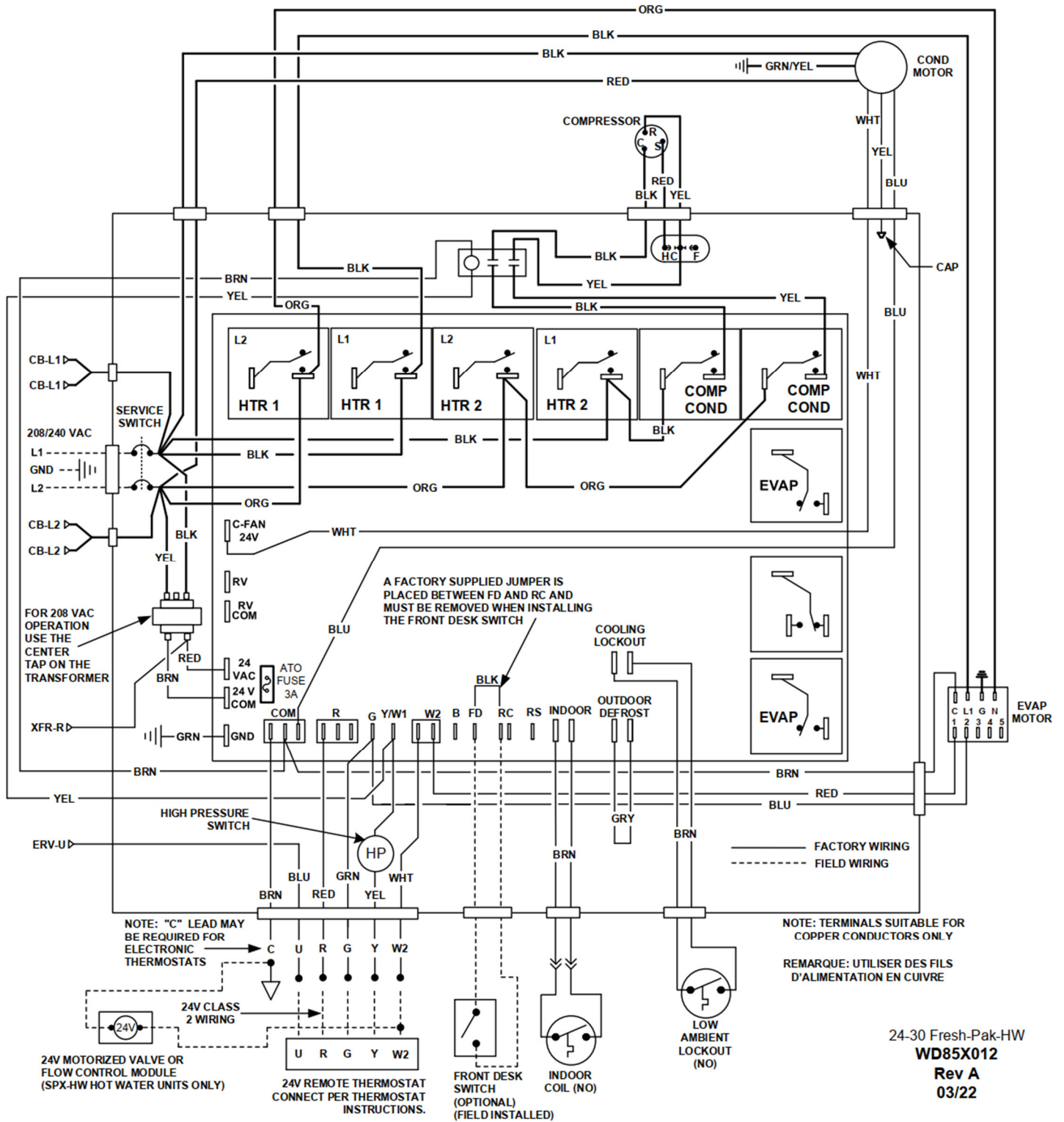

FIGURE 34 - WD85X012 Wiring Diagram

24-30 Fresh-Pak-HW
WD85X012
 Rev A
 03/22

WIRING DIAGRAMS (continued)

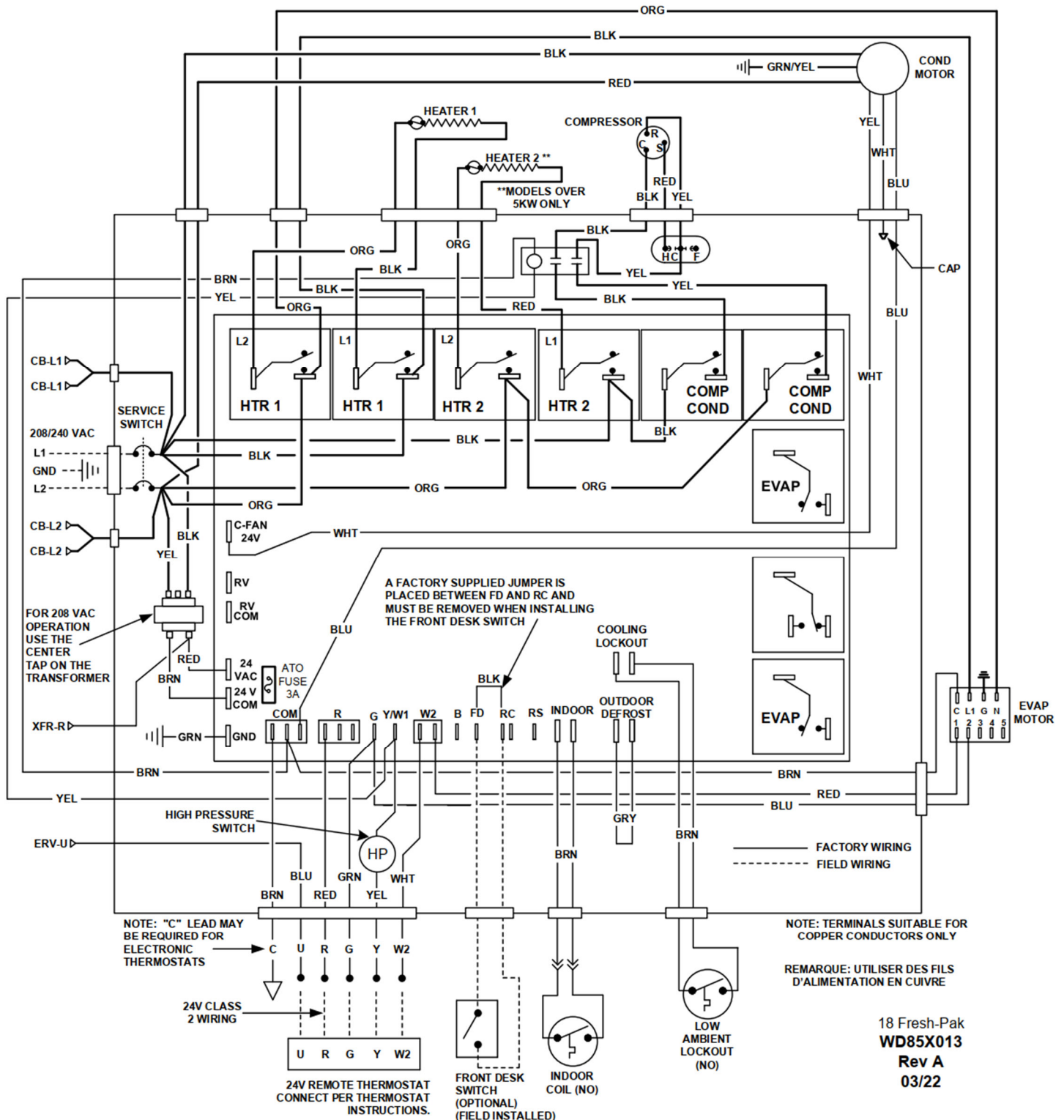

FIGURE 35 - WD85X013 Wiring Diagram

18 Fresh-Pak
WD85X013
 Rev A
 03/22

WIRING DIAGRAMS (continued)

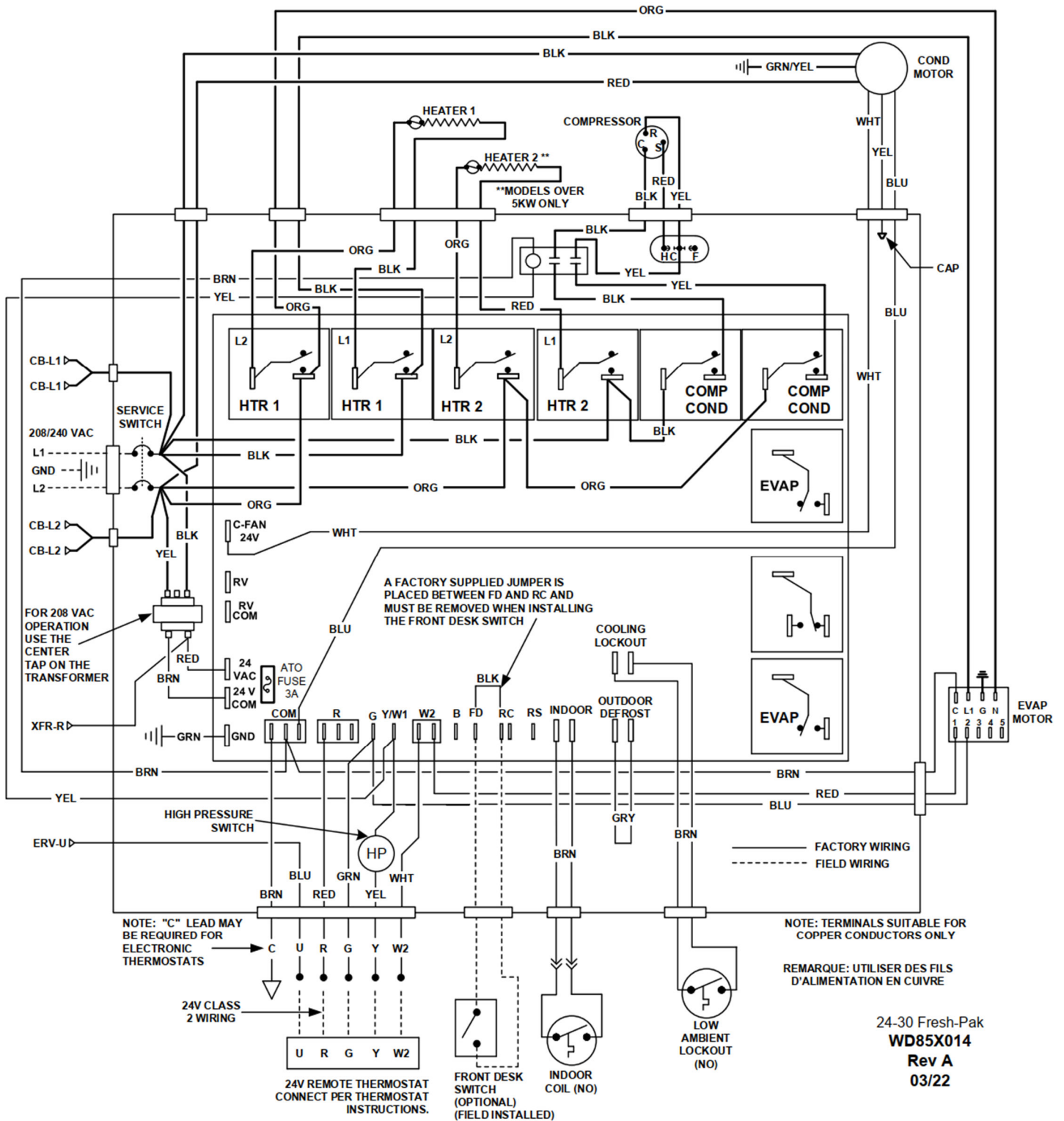

FIGURE 36 - WD85X014 Wiring Diagram

24-30 Fresh-Pak
WD85X014
 Rev A
 03/22

CIRCUIT SCHEMATIC

COOLING & HOT WATER ONLY

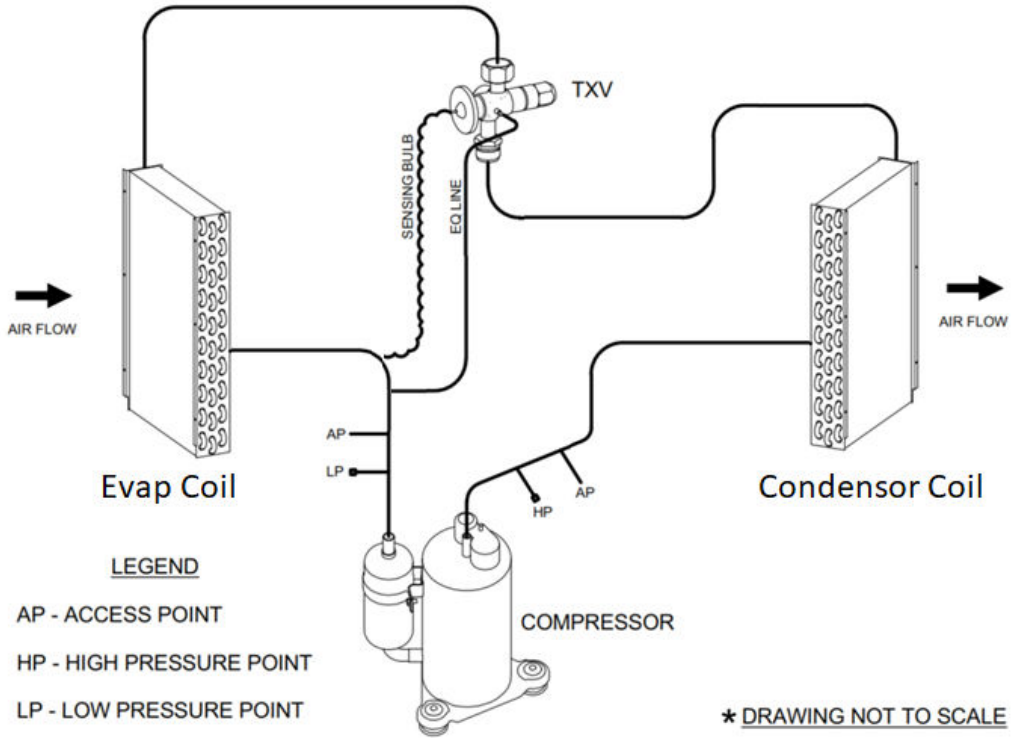

FIGURE 37 - Circuit Schematic (Cooling & Hot Water)

STARTUP INSTRUCTIONS

PRE-STARTUP CHECKS

Before start-up, thoroughly check all the components. Optimal operation of equipment requires cleanliness. Often after installation of the equipment, additional construction activities occur. Protect the equipment from debris during these construction phases.



WARNING



Electrically ground the unit by connecting ground wire to ground lug. Failure to properly ground the unit may result in personal injury or death.



CAUTION



Wire any field installed device such as a fan switch or thermostat furnished by the factory in strict accordance with the wiring diagram supplied with the unit. Failure to properly wire the unit could result in damage to components and will void all warranties.

PRIOR TO THE STARTUP OF THE UNIT

1. Ensure supply voltage matches nameplate data.
2. Ensure the unit is properly grounded
3. With the power off, check blower wheel set screws for proper tightness and that the blower wheel rotates freely.
4. Ensure unit will be accessible for servicing.
5. Ensure condensate line is properly sized, run, trapped, pitched and tested.
6. Ensure all cabinet openings and wiring connections have been sealed.
7. Ensure clean filters are in place.
8. Ensure all access panels are in place and secured.
9. Ensure that all air has been vented from the water coil.
10. Verify that all electrical connections are tight and secure.
11. Check the electrical overcurrent protection and wiring for the correct size.
12. Verify that the low voltage wiring between the thermostat and the unit matches the wiring diagram.
13. Verify that the water piping is complete and correct.
14. Check condensate overflow sensor for proper operation and adjust position if required.

FRESH-PAK COOLING/ELECTRIC HEAT UNITS

1. Set thermostat system switch to "OFF" position and fan switch to "Auto" position. Apply power to the FRESH-PAK Unit.



NOTE



The FRESH-PAK employs a random reset timer which delays unit operation up to 60 seconds following initial power application. Electronic thermostats may also employ internal reset timers which may further delay any changes which are made to the operation of the unit.

2. Set fan switch to "On", indoor blower should operate after the reset timer cycle is complete.
3. Return fan switch to "Auto", indoor blower should de-energize.
4. Set system switch to "Cool" and lower the thermostat set point to coldest setting. The compressor should energize as well as the outdoor fan and indoor blower.



NOTE



The FRESH-PAK employs a compressor short cycle delay (approx. 6 minutes) which will not allow the compressor to immediately restart following shut down. Additional delays may be experienced if using an electronic digital thermostat.

5. Return thermostat set point to a temperature warmer than a room temperature and the compressor and outdoor fan should de-energize. The indoor blower should remain in operation for an additional 45 seconds, then de-energize.
6. Move system switch to "Heat" and raise thermostat to a set point higher than room temperature. The indoor blower and electric heating element(s) should energize.
7. Return system switch to "Off" position.



NOTE



The FRESH-PAK employs a random reset timer which delays unit operation up to 60 seconds following initial power application. Electronic thermostats may also employ internal reset timers which may further delay any changes which are made to the operation of the unit.

STARTUP INSTRUCTIONS (continued)



NOTE



The FRESH-PAK employs a compressor short cycle delay (approx. 6 minutes) which will not allow the compressor to immediately restart following shut down. Additional delays may be experienced if using an electronic digital thermostat.



NOTE



The FRESH-PAK employs a compressor lock out which will not allow the compressor and electric heaters to energize at the same time.



NOTE



The FRESH-PAK features a low ambient compressor lock out switch, which limits the refrigerant system operation when the sensor detects a temperature less than 40°F in the outdoor section of the cabinet.

FRESH-PAK COOLING WITH HOT WATER UNITS

1. Set thermostat system switch to “Off” position and fan switch to “Auto” position. Apply power to the FRESH-PAK HW unit.



NOTE



The FRESH-PAK employs a random reset timer which delays unit operation up to 60 seconds following initial power application. Electronic thermostats may also employ internal reset timers which may further delay any changes which are made to the operation of the unit.

2. Set fan switch to “On”, indoor blower should operate after the rest timer cycle is complete.
3. Return fan switch to “Auto”, indoor blower should de-energize.
4. Set system switch to “Cool” and lower thermostat set point to coldest setting. The compressor should energize as well as the outdoor fan and the indoor blower.
5. Return thermostat set point to a temperature warmer than a room temperature and the compressor and outdoor fan should de-energize. The indoor blower should remain in operation for an additional 45 seconds, then de-energize.
6. Move system switch to “Heat” and raise the thermostat to a set point higher than room temperature. The indoor blower and field supplied motorized valve should energize.
7. Lower the set point to less than room temperature and the system should d-energize.
8. Return system switch to “Off” position.

STARTUP & PERFORMANCE CHECKLIST INSTRUCTIONS:

The warranty may be void unless is completed and returned to the warrantor. If the unit is not installed properly the warranty will be void as the manufacturer will not be held accountable for problems that stem from improper installation.

TROUBLESHOOTING

PROBLEM	POSSIBLE CAUSE	CHECKS & CORRECTIONS
ENTIRE UNIT DOES NOT RUN	Power supply off	Apply power; close disconnect.
	Blown Fuse	Replace fuse or reset circuit breaker. Check for correct fuses.
	Voltage supply low	If voltage is below minimum voltage specified on unit data plate, contact lower power company.
	Thermostat	Set the fan to "ON", the fan should run. Set thermostat to "COOL" and lowest temperature setting, the unit should run in the cooling mode. If neither the blower nor compressor run in either case, the thermostat could be mis-wired or faulty. To ensure mis-wired or faulty thermostat verify 24 volts is available on the condenser section low voltage terminal strip between "R" and "C", "Y" and "C". If blower does not operate, verify 24 volts between terminals "G" and "C" in the air handler. Replace the thermostat if defective.
BLOWER OPERATES BUT COMPRESSOR DOES NOT RUN	Thermostat	Check setting, calibration and wiring.
	Wiring	Check for loose or broken wires at compressor, capacitor or contractor.
	Compressor overload open	If the compressor is cool and the overload will not reset, replace the compressor.
	Compressor motor grounded	Internal wiring grounded to the compressor shell. Replace compressor. If compressor burnout, install new filter dryer.
	Compressor windings open	After compressor has cooled, check continually of compressor windings. If the windings are open, replace the compressor.
UNIT OFF ON HIGH PRESSURE CONTROL	Discharge pressure too high	In "COOLING" mode: Lack of or inadequate water flow. Entering water temperature too warm. Scaled or restricted water to refrigerant heat exchanger.
	Refrigerant charge	The unit is overcharged with refrigerant. Reclaim refrigerant, evacuate and recharge with factory recommended charge.
	High pressure switch	Check for defective or improperly calibrated high-pressure switch.
UNIT OFF ON LOW PRESSURE CONTROL	Suction Pressure too low	In "COOLING" mode: Lack of or inadequate airflow. Entering air temperature too cold. Blower inoperative, clogged filter or restriction in ductwork.
	Refrigerant charge	The unit is low on refrigerant. Check for refrigerant leak, repair, evacuate and recharge with factor recommended charge.
	Low pressure switch	Check for defective or improperly calibrated low-pressure switch.
UNIT SHORT CYCLES	Unit oversized	Recalculate heating and cooling loads.
	Thermostat	Thermostat installed near a supply air register, relocate thermostat. Check heat anticipator.
	Wiring and controls	Loose connections in the wiring or a defective compressor contactor.

Table 13 - Troubleshooting Table (1 of 2)

TROUBLESHOOTING (continued)

PROBLEM	POSSIBLE CAUSE	CHECKS & CORRECTIONS
INSUFFICIENT COOLING OR HEATING	Unit undersized	Recalculate heating and cooling loads. If not excessive, possibly adding insulation will rectify the situation.
	Loss of conditioned air by leaks	Check for leaks in ductwork or introduction of ambient air through doors or windows.
	Airflow	Lack of adequate airflow or improper distribution of air. Replace dirty air filter.
	Refrigerant charge	Low on refrigerant charge causing inefficient operation.
	Compressor	Check for defective compressor. If discharge is too low and suction pressure is too high, compressor is not pumping properly. Replace compressor.
	Reversing valve	Defective reversing valve creating bypass of refrigerant from discharge to suction side of compressor. Discharge is too low and suction is too high. Replace reversing valve.
	Operating pressures	Compare unit operating pressures to the pressure / temperature chart for the unit.
	Refrigerant metering device	Check for possible restriction or defect. Replace is necessary.
	Moisture, non-condensable	The refrigerant system may be contaminated with moisture or non-condensable. Reclaim refrigerant, evacuate and recharge with factory recommended charge.

Table 14 - Troubleshooting Table (2 of 2)

ERV ALARM CODES

ALARM CODES (ERV)		
STATE	SITUATION	ALARM RELAY
Normal	Everything works normally	Open
Alarm, unacknowledged	Problem detected by controller and alarm activated	Closed
Alarm, acknowledged	Problem still existing, service man acknowledged the active alarm	Open
Normal, acknowledged	Problem fixed / eliminated, alarm is acknowledged For A-Alarm: Reset pending to unlock unit For B-Alarm: Works normal.	Open
Normal, unacknowledged	Problem fixed / eliminated, but alarm is not acknowledged	Closed

Table 15 - Alarm Codes (ERV)

A-ALARMS

In the case of critical A-Alarms, the application operation is locked in shut down mode until the alarm is acknowledged and reset.

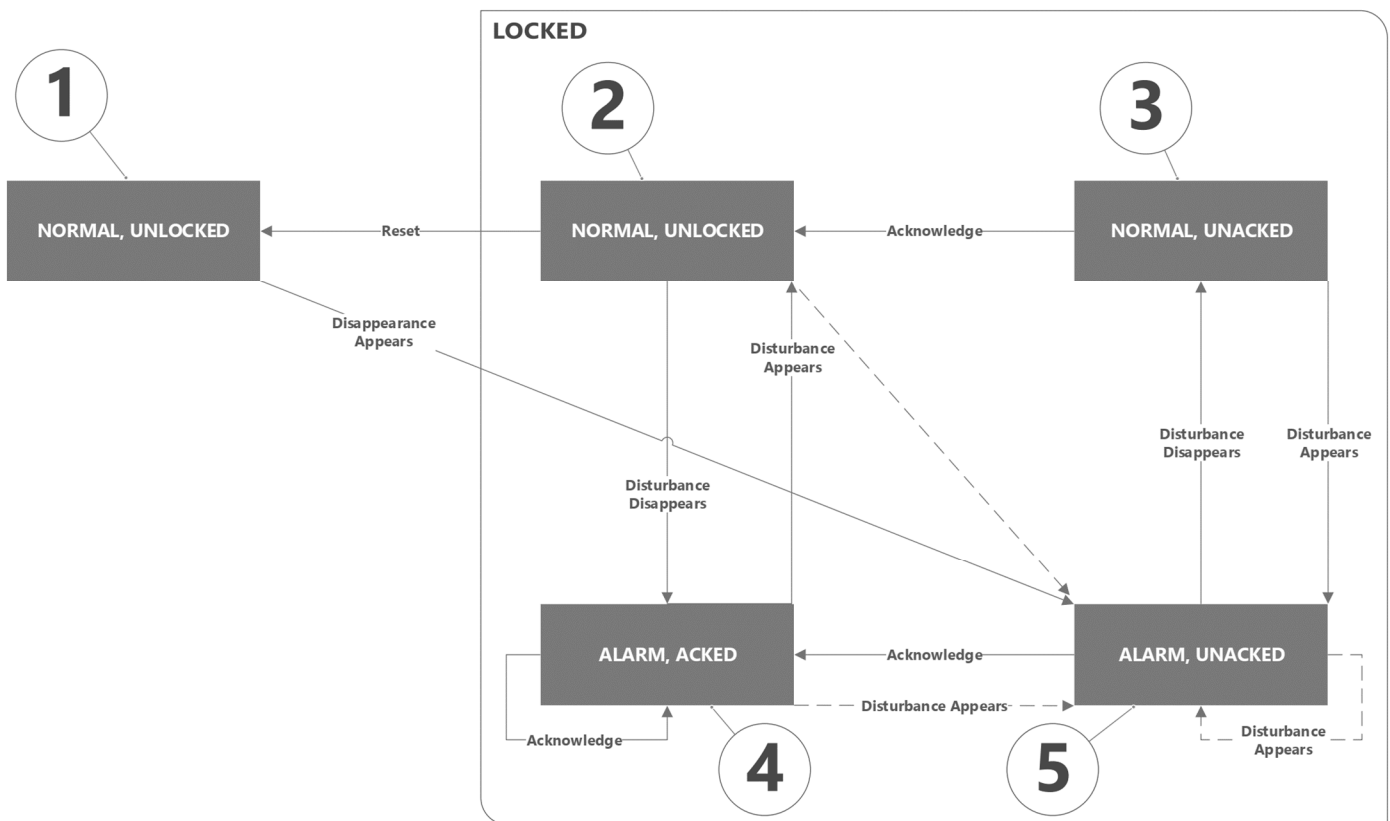

Figure 38 - A-Alarms Application Operation Key

A-ALARMS APPLICATIONS OPERATION KEY			
	ALARM	LOCKED	UNACKNOWLEDGED
1	0	0	0
2	0	1	0
3	0	1	1
4	1	1	0
5	1	1	1

Table 16 - A-Alarms Application Operation Key

ERV ALARM CODES (continued)

B-ALARMS

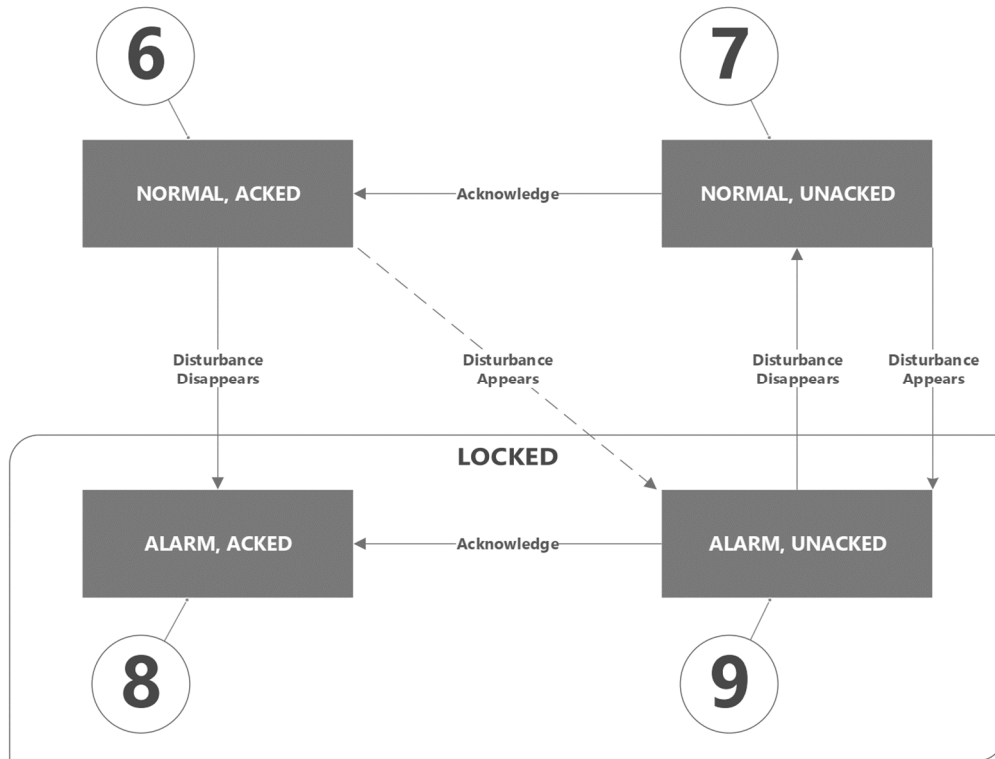

FIGURE 39 - B-Alarms Application Operation Key

B-ALARMS APPLICATIONS OPERATION KEY			
	ALARM	LOCKED	UNACKNOWLEDGED
1	0	0	0
2	0	1	0
3	0	1	1
4	1	1	0
5	1	1	1

Table 17 - B-Alarms Application Operation Key

ERV ALARM CODES (continued)

AVAILABLE PARAMETERS

AVAILABLE PARAMETERS			
ACKNOWLEDGE AND RESET	BACNET OBJECT	R/RW	NOTE
A-Alarm acknowledgement	AalmAck MVAL,137	RW	1: Ready 2: Acknowledge 3: Reset Automatic return to 1
B-Alarm acknowledgement	BalmAck MVAL,133	RW	1: Ready 2: Acknowledge Automatic return to 1
A-ALARMS	BACNET OBJECT	R/RW	NOTE
A-Alarm state	AalmSta MVAL, 135	R	1: Acknowledged, unlocked 2: Unacknowledged 3: Reset Automatic return to 1
A-Alarm indication	AalmInd MVAL, 136	R	1: Normal 2: Alarm
A-Alarm code	AalmCode AVAL, 49	R	0...9999
B-ALARMS	BACNET OBJECT	R/RW	NOTE
B-Alarm state	BalmSta MVAL, 132	R	1: Acknowledged, unlocked 2: Unacknowledged 3: Reset Automatic return to 1
B-Alarm indication	BalmInd MVAL, 131	R	1: Normal 2: Alarm
B-Alarm code	BalmCode AVAL, 43	R	0...9999
ALARM CLASS SETTINGS	BACNET OBJECT	R/RW	NOTE
Alarm configuration for outside air temperature	AlmCnfTOa MVAL,141	RW	1: A-Alarm 2: B-Alarm
Alarm configuration for heat exchanger	AlmCnfHExg MVAL,348	RW	1: A-Alarm 2: B-Alarm 3: None
Alarm configuration for all fan errors (Feedback fault, error signal or Modbus interrupted)	AlmCnfFanFb MVAL,349	RW	1: A-Alarm 2: B-Alarm 3: None (No fan error supervision. – Do not use “None for Modbus fans)

Table 18 - Available Parameters

Error codes are divided in different groups for easier recognition of the alarm source. Those groups are identified in the table below.

ERROR CODES	
ERROR CODE	ERROR SOURCE
1000--1999	Hardware related errors
2000--2999	Application related errors
3000--3999	Communication errors
9000--9999	3 rd party related errors

Table 19 - Error Codes

ERV ALARM CODES (continued)

CODE RANGES – HARDWARE

CODE RANGES – HARDWARE						
CODE	ALARM CLASS	NAME/DESCRIPTION	SOURCE	PLANT LOCK	BACNET OBJECT/COMMENT	INFLUENCE OF ALARM
1001	A	Supply air temperature, Sensor fault	System	Stop	TSu	Shutdown AHU
1002	A/B	Exhaust air temperature, sensor fault	System	Run	TEh, Active only if sensor available	Shutdown AHU/ No Heat exchanger supervision possible
1003	B	Extract air temperature, sensor fault	System	Run	TEx, Active only if sensor available	Fallback to room temperature control or supply air control
1004	A/B	Outside air temperature sensor fault	System	Conf.	TOa	Shutdown AHU / fallback to default
1005	A	Frost protection temperature for heating coil, sensor fault	System	Stop	TFRPrHcl Active only if HclHW selected	Shutdown AHU, Frost protection mode
1006	B	Relative humidity for extract air, sensor fault	System	Run	HuRelEx, Active only if sensor available	Stop Humidity control if all sensors fail
1009	A	Fire damper position, feedback fault	Process	Stop	FdpFb, Active only if Fdp selected. Plausibility check of fire damper position feedback	Shutdown AHU
1012	B	Room Temperature, sensor fault	System	Run	TR with POS8/QMX3	Fallback to extract temperature control or supply air control
1013	B	Room air quality, sensor fault	System	Run	AQualR with QMX3 or PmR	Stop air quality control if all sensors fail
1014	B	Extract air quality, sensor fault	System	Run	PmR or AQualR, Particulate matters, Air quality	Stop control if all sensors fail
1017	B	Room air humidity, sensor fault	System	Run	HuRelR, Active only if sensor available	Stop Humidity control if all sensors fail
1018	A/B	Supply air temp. after preheating coil, sensor fault	System	Run	TSuAfPreHcl, Active only if sensor available	Shutdown AHU / Shutdown electric preheating coil, fallback value for heat exchanger efficiency
1019	B	Flow temperature preheating coil, sensor fault	System	Run	TFIPreHcl, Active only if sensor available	Fallback to default value
1020	B	Air filter, dirty	Process	Run	Operating hour of air filter exceeds limit or delta P, active only if FilA selected	No reaction
1021	B	Supply air temperature after heat exchanger, sensor fault	System	Run	TsuAfHEXg, Active only if sensor available	Fallback value for Hexg efficiency calculation
1031	A/B/n	Heat Exchanger fault	Process	Run	RotHEXgFlt or HEXgCdnMon	Shutdown AHU / Bypass or shutdown HEXg / no reaction
1037	A/B/n	Supply air fan fault	Process	Conf.	FanSuSpdFb, FanSuFlt Check of fan speed feedback or fault signal	Shutdown AHU / No reaction / No reaction
1038	A/B/n	Exhaust air fan fault	Process	Conf.	FanSuSpdFb, FanSuFlt Check of fan speed feedback or fault signal	Shutdown AHU / No reaction / No reaction
2001	A	Emergency off	Process	Stop	EngOff (BI)	AHU off
2002	A	Smoke detector	Process	Stop	Smext (BI)	Smoke extract mode
2004	A	Fire Alarm	Process	Stop	Supply (TSu) or extract (TEx) air temperature exceeds max limit	Shutdown extract mode
2005	B	Supply air temperature, exceeds operating limits	Process	Stop	Supply air temperature (TSu) exceeds min/max limits	No reaction
2012	A	Preheating coil, over temperature	Process	Stop	PreHclOvrTDet, active only if PreHclEI selected	Shutdown AHU
2013	A	Outside air damper stops air flow	Process	Stop		Shutdown AHU
2017	A/B/n	Heat exchanger efficiency supervision	Process	Conf.	Plausibility check of air temperatures	Shutdown AHU / Bypass or shutdown / no reaction

Table 20 - Code Ranges - Hardware

ERV ALARM CODES (continued)

CODE RANGES – COMMUNICATION

CODE RANGES – HARDWARE						
CODE	ALARM CLASS	NAME/DESCRIPTION	SOURCE	PLANT LOCK	BACNET OBJECT/COMMENT	INFLUENCE OF ALARM
3005	B	I/O extension module, Modbus communication fault	System	Run	POS9 active only if device configured	Same reaction as for each connection input
3011	B	Duct pressure sensor, Modbus communication error	System	Run	QBM, Active only if device configured	Fallback to linear Fan speed
3012	A/B	Supply air fan, Modbus communication fault	System	Conf.	Active only if Modbus fan configured	A: Shutdown AHU / B: No reaction Reaction of fan based on fan device configuration
3101	B	Room sensor, KNX PL-Link communication error	System	Run	Common fault for all PL-Link room devices: POS8.4420/4440, QMX3.P30/P40/P70 Active only if device configured	

Table 21 - Code Ranges - Hardware

MAINTENANCE & SERVICE



PREVENTIVE MAINTENANCE

To achieve maximum performance and service life of equipment, a formal schedule of regular maintenance should be established and adhered to.

If servicing or major repairs are required, the complete unit can be removed as follows:



1. Disconnect the electrical power circuit supplying the unit.
2. Remove line and low voltage wiring from unit,
3. Remove rear access panel.
4. Remove supply duct from top of unit.
5. Slide unit back out of sleeve.
6. Unit may be removed from closet.

To reinstall unit, use the installation procedure outlined above.

WARNING

It is a violation of federal law to discharge refrigerant into the atmosphere. Use proper reclaiming methods and equipment when installing or servicing this unit. Service should be performed by a **QUALIFIED** service agency.

The refrigerant system contained in the unit normally requires no maintenance since it is a closed, self-contained system.



CAUTION



All appropriate personal protection equipment should be worn when servicing or maintaining this unit.

Personal injury can result from contact with sharp metal edges, moving parts, and hot or cold surfaces.

FAN

The fan should be inspected and cleaned annually in conjunction with maintenance of the motor and bearings. It is important to keep the fan section and motor clean and free from obstruction to prevent imbalance, vibration, and improper operation.

WARNING



ELECTRIC SHOCK HAZARD

Check motor connections to ensure they are secure and in accordance with the unit wiring diagram.

ECM motors have line voltage power applied at all times.
VERIFY THAT POWER IS DISCONNECTED BEFORE SERVICING.

FILTER

The air filter and ERV filters should be cleaned or replaced every 30 days or more frequently if severe operating conditions exist. Always replace the filter with the same type and size as originally furnished.

ERV CORE

The Energy Recovery plate heat exchanger (CORE), should be inspected at least twice (2) times a year. The CORE should be removed and cleaned as needed at least once (1) per year. The CORE can be cleaned with light air pressure or with a mild detergent and water solution. Be sure that the CORE is completely dry before reinserting it back into the ERV.

ERV INSULATION

The ERV interior should be inspected with the CORE (2 times a year). Check and clean the cabinet interior of all dirt and debris.

COIL

Clean all heat transfer surfaces and remove all dirt, dust, and contaminants that potentially impairs air flow using industry accepted practices. Care should be taken not to bend coil fin material.

CONDENSATE DRAIN PAN AND PIPE

Check and clean all dirt and debris from pan. Ensure drain line is free flowing and unobstructed.

MAINTENANCE UPDATES

Contact First Co. Technical Support for maintenance updates.

UNIT PERFORMANCE

Record performance measurements of volts, amps and water temperature differences (both heating and cooling). A comparison of logged data with start-up and other annual data is useful as an indicator of general equipment condition.

UNIT LOCKOUT

Air or water problems could cause periodic lockouts. The lockout (shutdown) of the units is a normal protective result. Check for dirt in the water system, water flow rates, water temperatures, airflow rates (may be caused by dirty filter) and air temperatures.

LABORATORY TESTING

When the unit has less than 100 operational hours and the coils have not had sufficient time to be "seasoned", it is necessary to clean the coils with mild surfactant such as Calgon to remove the oils left by manufacturing processes.

PERFORMANCE TABLES

ERV EFFECTIVENESS TABLE							
SUPPLY TEMPERATURE		RELATIVE HUMIDITY	SUPPLY AIR FLOW		RECOVERY		
°C	°F		L/s	CFM	SENSIBLE	LATENT	TOTAL
		RH %	Effectiveness %				
2	35	80	47	100	62.4	41.9	54.7
0	32	80	23	50	70.7	53.6	65
0	32	80	37	80	65.4	46	59
0	32	80	56	120	59.7	38.5	52.7
-25	-13	80	47	100	65.4	41.9	56.2

Table 22 - ERV Effectiveness

VENTILATION PERFORMANCE					
EXTERNAL STATIC PRESSURE		SUPPLY AIR FLOW		EXHAUST AIR FLOW	
Pa	in. W.C.	L/s	Pa	L/s	Pa
25	0.1	60	123	60	126
50	0.2	56	120	56	120
75	0.3	55	116	55	116
100	0.4	52	109	52	109
125	0.5	49	104	49	104
150	0.6	47	100	47	100
175	0.7	46	97	46	97
200	0.8	41	88	41	88
225	0.9	37	79	37	79
250	1	34	72	34	72

Table 23 - Ventilation Performance

SUPPORT MATERIAL

ASHRAE 62.2 VENTILATION STANDARD TABLES

ASHRAE 62.2 CFM Sizing Chart					
FLOOR AREA	NUMBER OF BEDROOMS / CFM				
	0-1	2-3	4-5	6-7	>7
< 1500	30	45	60	75	90
1501 – 3000	45	60	75	90	105
3001 – 4500	60	75	90	105	120
4501 – 6000	75	90	105	120	135
6001 – 7500	90	105	120	135	150
> 7500	105	120	135	150	165

ANSI/ASHRAE STANDARD 62.2-2010 – Ventilation Air Requirements; values in cfm. The above chart outlines the minimum requirements for continuous ventilation.

Table 24 - ASHRAE 62.2 CFM Sizing Chart

ROOM COUNT CALCULATION METHOD TABLE				
LIVING SPACE	NUMBER OF ROOMS	X CFM (or L/s)	=	CFM Required
Master Bedroom		x 20 cfm (for 10 L/s)	=	
Basement		x 20 cfm (for 10 L/s)	=	
Single Bedroom		x 10 cfm (for 5 L/s)	=	
Living Room		x 10 cfm (for 5 L/s)	=	
Dining Room		x 10 cfm (for 5 L/s)	=	
Family Room		x 10 cfm (for 5 L/s)	=	
Recreation Room		x 10 cfm (for 5 L/s)	=	
Other		x 10 cfm (for 5 L/s)	=	
Kitchen		x 10 cfm (for 5 L/s)	=	
Bathroom		x 10 cfm (for 5 L/s)	=	
Laundry Room		x 10 cfm (for 5 L/s)	=	
Utility Room		x 10 cfm (for 5 L/s)	=	
TOTAL VENTILATION REQUIREMENT			=	

Table 25 - Room Count Calculation Method Table

STARTUP & PERFORMANCE CHECKLIST INSTRUCTIONS



CUSTOMER _____ STARTUP DATE _____ JOB # _____
 ADDRESS _____ SERVICING COMPANY _____
 _____ TECHNICIAN _____
 MODEL # _____ SERIAL # _____ PHONE # _____

INSTALLATION CHECK LIST

- Inspect the unit for transit damage and report any damage on the carrier's freight bill.
- Check model number to insure it matches the job requirements.
- Install field accessories and unit adapter panels as required. Follow accessory and unit installation manuals.
- Verify field wiring, including the wiring to any accessories.
- Check all multi-tap transformers, to insure they are set to the proper incoming voltage.
- Prior to energizing the unit, inspect all the electrical connections.
- Power the unit. Bump the motor contractor to check rotation. Three phase motors are synchronized at the factory. If the blower fans are running backwards, de-energize power to the unit, then swap two of the three incoming electrical lines to obtain proper phasing. Re-check.
- Perform all start up procedures outline in the installation manual shipped with the unit.
- Fill in the Start Up Information as outlined below and on the following page.
- Provide owner with information packet. Explain the thermostat and unit operation.

START UP INFORMATION SHEET

ELECTRICAL

Supply Voltage L1-L2 _____ Compressor Amps _____
 Running Voltage L1-L2 _____ Blower Amps _____
 Secondary Voltage _____ Condenser Fan Amps _____
 C (black) to G (green) Volts* _____
 C (black) to W (white) Volts* _____ *With thermostat calling.

AMPERAGE – ERV MOTORS

Intake Motor: Nominal HP _____
 Rated Amps _____
 Running Amps _____
 Exhaust Motor: Nominal HP _____
 Rated Amps _____
 Running Amps _____

AIRFLOW

Intake Design CFM _____ Exhaust Design CFM _____
 Pressure Drop _____ Pressure Drop _____
 Calculated CFM _____ Calculated CFM _____
 Amb db Temp _____ Amb db Temp _____
 Return Air db Temp* _____ Return Air db Temp* _____
 Tempered Air db Temp* _____ Tempered Air db Temp* _____
*Measure after 15 minutes of run time

TEMPERATURES

Outdoor Air Temperature _____ DB _____ WB _____
 Cooling Supply Air Temperature _____ DB _____ WB _____
 Return Air Temperature _____ DB _____ WB _____
 Heating Supply Air Temperature _____ DB _____ WB _____

DOCUMENT #: _____

FIGURE 40 - Startup & Performance Checklist (1 of 2)

STARTUP & PERFORMANCE CHECKLIST (continued)



UNIT OPERATION

HEATING MODE

- 1 INDOOR BLOWER AMPS _____
- 2 TEMPERATURE RISE
 - Supply Duct Temperature _____
 - Return Duct Temperature - _____
 - Temperature Rise = _____
- 3 TOTAL EXTERNAL STATIC
 - Supply Duct Temperature _____
 - Return Duct Temperature + _____
 - Temperature Rise = _____
- 4 CONDENSATE LINE
 - Leak Free

COOLING MODE

- 5 INDOOR BLOWER AMPS _____
- 6 TEMPERATURE DROP
 - Return Duct Temperature _____
 - Supply Duct Temperature - _____
 - Temperature Drop = _____
- 7 TOTAL EXTERNAL STATIC
 - Supply External Static _____
 - Return External Static + _____
 - Total External Static = _____
- 8 DRAIN LINE
 - Leak Free
- 9 THERMOSTAT
 - Adjusted & Programmed
 - Explained Operation to Owner

The warranty may be void unless the Startup & Performance Checklist is completed and returned to the warrantor. If the HVAC unit is not installed properly the warranty will be void as the manufacturer can't be held accountable for problems that stem from improper installation.

FIGURE 41 - Startup & Performance Checklist (2 of 2)

NOTES



P.O. Box 270969 Dallas, TX 75227
www.firstco.com or www.ae-air.com

The manufacturer works to continually improve its products. It reserves the right to change design and specifications without notice.

©2022 First Co., Applied Environmental Air