

Installation, Operation, & Maintenance

IOM 7301
Rev. B 1/25

CLX, CLXW, CLXQ, CLP, CLPW, CLPQ FAN COIL UNITS

ATTENTION:

Read all instructions thoroughly and retain all manuals for future reference.



COPYRIGHT

The Manufacturer works to continually improve its products and as a result, it reserves the right to change design and specifications without notice.



WARNING



Altering the product or replacing parts with non-authorized factory parts voids all warranty or implied warranty and may result in adverse operational performance and/or a possible hazardous condition to service personnel and occupants. Company employees and/or contractors are not authorized to waive this warning.



WARNING



Only personnel trained and qualified in the installation, adjustment, servicing, maintenance, or repair of the equipment described in this manual should perform service. The manufacturer is not responsible for any injury or property damage arising from improper service or procedures. In jurisdictions where licensing is required to service this equipment, only licensed personnel should perform the service.

Improper installation, adjustment, servicing, maintenance, or repair—or attempting to perform these tasks without proper training—may result in product damage, property damage, personal injury, or death. Service personnel assume responsibility for any injury or property damage resulting from improper procedures.

TABLE OF CONTENTS

SAFETY CONSIDERATIONS	4
SAFETY INFORMATION	5
MODEL NOMENCLATURE	6
INSTALLATION PRECAUTIONS	7-8
GENERAL	8
LOCATION AND CLEARANCE	9
FAN COIL UNIT	9
AIR DISTRIBUTION DUCTS	10
ELECTRICAL	10
MOUNTING	10
COOLING COIL PIPING	11
HOT WATER COIL PIPING PRECAUTIONS	12
LEAK CHECK	12
REFRIGERANT CHARGING	12-14
ELECTRICAL DATA	15-16
OPERATION MAINTENANCE	17-26
MINIMUM ROOM SIZE AND MITIGATION AIRFLOW	27-28
A2L SENSOR MOUNTING	29
DIMENSIONS	30-31
NOTES	32

SAFETY CONSIDERATIONS



1. READ THE ENTIRE MANUAL BEFORE STARTING THE INSTALLATION.
2. Improper installation, adjustment, alteration, service, maintenance, or use can cause explosion, fire, electrical shock, or other conditions which may cause personal injury damage.
3. Consult a qualified licensed installer, service agency, or your distributor for information assistance. The qualified licensed installer or service agency must use factory-authorized kits or accessories when servicing this product.
4. Refer to the individual instructions packaged with kits or accessories when installing.
5. Follow all safety codes.
6. Read these instructions thoroughly and follow all warnings or cautions attached to the unit. Consult local building codes and National Electrical Code (NEC) for special requirements.

This appliance is not to be used by persons (including children) with reduced physical, sensory or mental capabilities, or lack of experience and knowledge, unless they have been given supervision or instruction.





Children should be supervised to ensure that they do not play with the appliance

Use adequate personal protection equipment when installing and performing maintenance. After switching off and locking-out an electrical disconnect, verify a safe condition with an electrical tester. Discharge a capacitor before handling any PSC motor and wiring. Use eye protection, cut resistant gloves and sleeves to protect against metal edges and screws.

RECOGNIZE THE FOLLOWING SAFETY NOTATIONS THROUGHOUT THIS MANUAL AND POSTED ON THE EQUIPMENT:

	WARNING	
Indicates a potentially hazardous situation or unsafe practices that could result in severe personal injury or death and/or damage to property		





	WARNING	
	FIRE OR EXPLOSION HAZARD	
Indicates a potential fire or explosion hazard that could result in personal injury, death and /or property damage.		

	WARNING	
	ELECTRIC SHOCK HAZARD	
This warning signifies potential electrical shock hazards that could result in personal injury or death.		

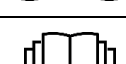

	CAUTION	
Indicates a potentially hazardous situation that may result in minor or moderate personal injury		

	IMPORTANT	
Suggests important procedure steps to insure proper installation, reliability, or operation		



	NOTE	
Used to highlight suggestions, which may result in enhanced installation, reliability or operation		

	Service indicator; read technical manual
	Operator's manual; operating instructions
	Read the instructions
	Warning; flammable materials
	UN GHS flame symbol

SAFETY INFORMATION



 **WARNING** 

 Risk of fire. Flammable refrigerant used. To be repaired only by trained service personnel. Do not puncture refrigerant tubing. Auxiliary devices which may be ignition sources shall not be installed in the ductwork, other than auxiliary devices listed for use with the specific appliance. See Instructions. Dispose of refrigerant properly in accordance with federal or local regulations. Failure to follow proper A2L refrigerant mitigation system installation instructions can result in property damage, personal injury, or death. If any fault indicators are present, please troubleshoot to prevent system malfunction.



 **WARNING** 

When a Refrigerant Leak Detection System is installed. The unit must be powered on at all times except for serving.



Installer must verify that the refrigerant sensor is properly installed and functioning or else the warranty will be voided. Failure to do so may result in fire, property damage or death.

 **WARNING** 

Work with extreme caution to minimize the risk of refrigerant ignition while installing and servicing a system containing a flammable refrigerant. Control the work environment as much as possible while potentially flammable vapors are present. Inform all persons on site about the risks of the nature of the work underway and the necessary safety precautions. Do not work in confined spaces. Test the work area for refrigerant in the air using an intrinsically safe A2L refrigerant leak detector before beginning work. Have a dry powder or CO2 fire extinguisher available. Use proper tools designed for A2L class refrigerants. While working near A2L refrigerants, use only non-sparking tools. Open flames and other ignition sources must not be present except during brazing. Brazing must only take place on evacuated and nitrogen purged refrigerant lines and components that are open to the atmosphere.

 **WARNING** 

These instructions are intended to aid qualified, licensed, service personnel in proper installation, adjustment and operation of this unit. Read these instructions thoroughly before attempting installation or operation. Failure to follow these instructions may result in improper installation, adjustment, service or maintenance possibly resulting in fire, electrical shock, property damage, personal injury or death.



 **WARNING** 

Electrical work associated with the installation of this appliance must comply with the National Electrical Code (NEC). Other local or regional electrical and building code requirements may apply. In Canada electrical work associated with the installation of this appliance must comply with CE CSA C22.1



 **IMPORTANT** 

This fan-coil must be installed in a location which is not accessible to the general public.

This appliance is for INDOOR USE ONLY.

 **WARNING** 

 When the unit is using flammable refrigerant and is installed in a room with an area less than that outlined in section **Minimum Room Size and Mitigation Airflow**, that room shall be without continuously operating open flames or other potential ignition sources.

 **WARNING** 

 Auxiliary devices that may serve as potential ignition sources must not be installed in the ductwork. Potential ignition sources include hot surfaces exceeding 700°C and electrical switching devices.

MODEL NOMENCLATURE

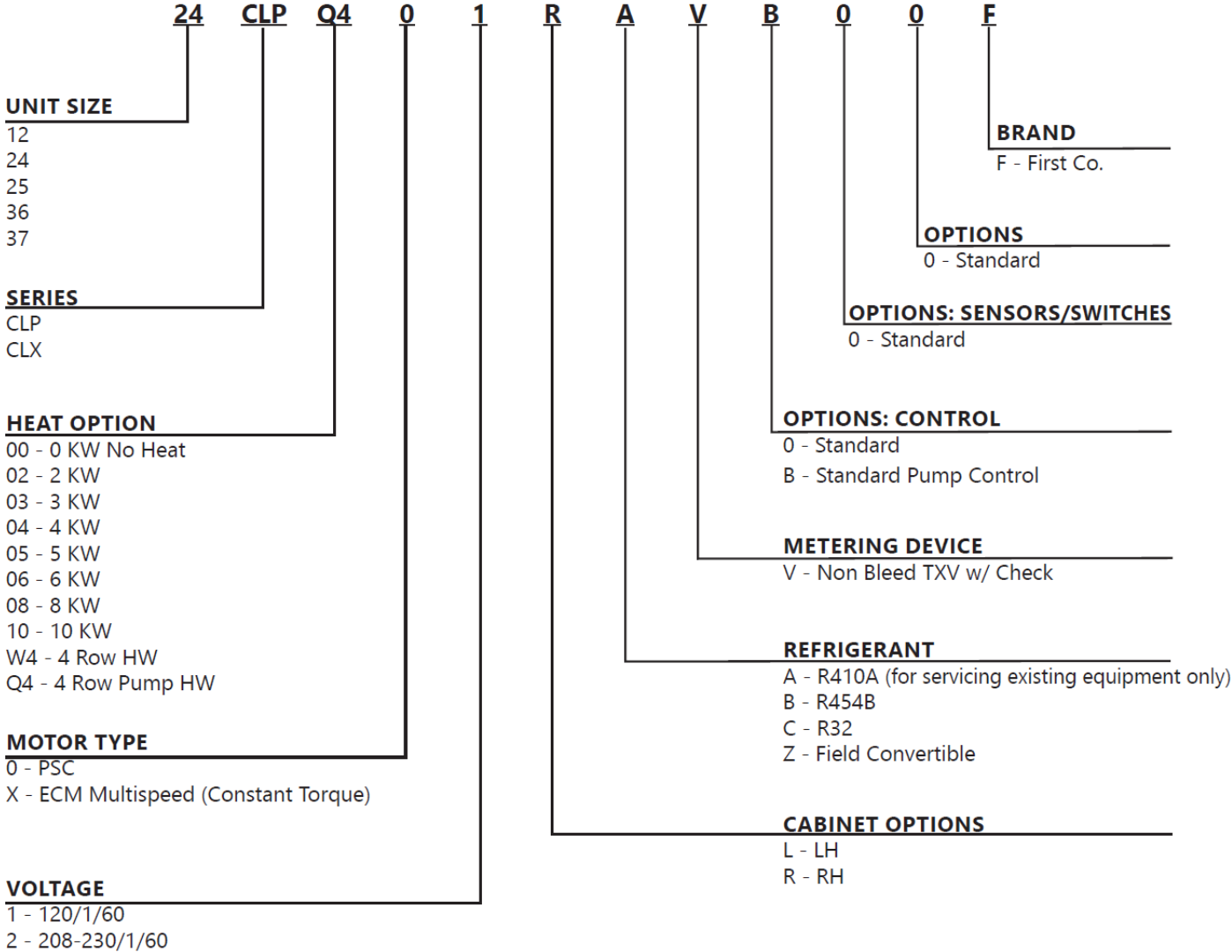

INSTALLATION PRECAUTIONS

WARNING

If hot water coil is connected to domestic potable water a hot water mixing valve can be applied to the system to temper domestic water draw.

WARNING

This appliance is not to be used by persons (including children) with reduced physical, sensory or mental capabilities, or lack of experience and knowledge, unless they have been given supervision or instruction.

Children should be supervised to ensure that they do not play with the appliance

Use adequate personal protection equipment when installing and performing maintenance. After switching off and locking-out an electrical disconnect, verify a safe condition with an electrical tester. Discharge a capacitor before handling any PSC motor and wiring. Use eye protection, cut resistant gloves and sleeves to protect against metal edges and screws.

WARNING

Use two or more people when moving and installing these units. Failure to do so could result in personal injury or death. Contact with metal edges and corners while applying excessive force can result in personal injury. Use gloves when handling equipment. Use caution during installation or while servicing equipment.

Installation of this fan coil should be performed only by a licensed contractor to ensure proper installation and the safety of the installer. Observe the following precautions for typical installations.

- Always use proper tools and equipment.
- No wiring or other work should be attempted without first ensuring fan coil is completely disconnected from the power source locked out. Always verify that a good permanent, uninterrupted ground connection exists prior to energizing any power sources.
- Always review the nameplate and wiring diagram on each unit for proper voltage and control

configurations. This information is determined from the components and wiring of the unit and may vary from unit to unit.

- When soldering or brazing to the unit, it is recommended to have a fire extinguisher readily available. When soldering close to water valves or other components, heat shields or wet rags are required to prevent damage.
- When the fan coil unit is in operation components are rotating at high speeds.
- Units must be installed level to ensure proper drainage and operation. These fan coils have a pitched drain pan for improved condensate drainage.
- Check unit prior to operation to ensure that the condensate water will drain toward the drain connection. An overflow drain or an auxiliary drain pan under the fan coil may be required as a back up to a clogged primary drain pan.
- Be sure the drain pan is free from foreign material prior to start up.
- Check the filter media installation to ensure that it is installed correctly. Use the directional arrows or other information on the filter to determine the proper flow direction.
- Ensure air distribution system does not exceed the external static rating of the unit.

WARNING

Do not exceed the maximum operating pressure or temperature listed on the unit's rating label.

UNITS WITHOUT PUMPS:

Water Pressure:	Max 400 psig (2758 kPa)
	Min 10 psig (69 kPa)
Water Temperature:	Max 180°F (82°C)
	Min 40°F (4°C)

UNITS WITH PUMPS:

Water Pressure:	Max 125 psig (862 kPa)
	Min 2 psig (14 kPa)
Water Temperature:	Max 180°F (82°C)
	Min 40°F (4°C)

INSTALLATION PRECAUTIONS

Insulation is installed in indoor equipment to provide a barrier between outside air conditions surrounding the unit and the varying conditions inside the unit. If the insulating barrier is damaged, the surrounding ambient air will affect the inside surface temperature of the cabinet. The temperature/humidity difference between the inside and outside can cause condensation to form on the inside and outside of the cabinet which leads to sheet metal corrosion and subsequently component failure.

Damaged insulation must be repaired or replaced before the unit is placed back into operation. Insulation loses its insulation value when wet, damaged, separated, or torn.

GENERAL

The manufacturer assumes no responsibility for equipment installed in violation of any code requirement.





These instructions give information relative to the installation of these fan coil units only. For other related equipment refer to the proper instructions.



Material in this shipment has been inspected at the factory and released to the transportation agency in good condition. When received, a visual inspection of all cartons should be made immediately. Any evidence of rough handling or apparent damage should be noted on the delivery receipt and the material inspected in the presence of the carrier's representative. If damage is found, a claim should be filed against the carrier immediately.



Work with extreme caution to minimize the risk of refrigerant ignition while installing and servicing a system containing a flammable refrigerant. Control the work environment as much as possible while potentially flammable vapors are present. Inform all persons on site about the risks of the nature of the work underway and the necessary safety precautions. Do not work in confined spaces. Test the work area for refrigerant in the air using an intrinsically safe A2L refrigerant leak detector before beginning work. Have a dry powder or CO2 fire extinguisher available. Use proper tools designed for A2L class refrigerants. While working near A2L refrigerants, use only non-sparking tools. Open flames and other ignition sources must not be present

except during brazing. Brazing must only take place on evacuated and nitrogen purged refrigerant lines and components that are open to the atmosphere.

CL models are wall / closet air handlers with a direct expansion coil for connection to a properly matched air conditioning or heat pump unit. A high efficiency constant torque ECM blower motor is available in the CLX model. CL units are also available with factory installed electric heat.

	WARNING	
	FIRE OR EXPLOSION HAZARD	
<p>Failure to following this warning could result in personal injury, death and/or property damage.</p> <p>Do not use flames or any potential ignition sources to leak check refrigerant tubing or components.</p>		

	WARNING	
<p>These instructions are intended as an aid to qualified, licensed, service personnel for proper installation, adjustment and operation of this unit. Read these instructions thoroughly before attempting installation or operation. Failure to follow these instructions may result in improper installation, adjustment, service or maintenance possibly resulting in fire, electrical shock, property damage, personal injury or death.</p>		

	IMPORTANT	
<p>This unit is a PARTIAL UNIT AIR CONDITIONER, complying with PARTIAL UNIT requirements of this Standard, and must only be connected to other units that have been confirmed as complying to the corresponding PARTIAL UNIT requirements of this Standard, UL 60335-2-40/CSA C22.2 No. 60335-2-40, or UL 1995/CSA C22.2 No.236</p>		

LOCATION AND CLEARANCE

Select a location that provides sufficient space for mounting and allows for ducting connections. Maintain a recommended clearance of 24 inches on all sides of the unit for service access. Units may be installed with "0" clearance to combustible materials. Always verify the specific clearance requirements on the unit's rating plate before installation.

For installations in areas that may lead to physical damage (e.g., a garage), it is recommended to install a protective barrier to shield the unit. Ensure the unit is installed with a positive slope in the condensate line of 1/4 inch per foot to allow for proper drainage.

All joints made during installation between parts of the refrigerating system must remain accessible for maintenance purposes. Consult all applicable regulatory codes and guidelines prior to determining final clearances and completing the installation.



WARNING



Do not use means to accelerate the defrosting process or to clean, other than those recommended by the manufacturer.

The appliance shall be stored in a room without continuously operating ignition sources (for example: open flames, an operating gas appliance or an operating electric heater).

Do not pierce or burn.

Be aware that refrigerants may not contain an odor.



WARNING



Improper installation, adjustment, alteration, service, maintenance, or use can cause explosion, fire, electrical shock, or other conditions which may cause personal injury or property damage. Consult a qualified licensed installer, service agency, or your distributor for information or assistance. The qualified licensed installer or service agency must use factory-authorized kits or accessories when modifying this product. Refer to the individual instructions packaged with kits or accessories when installing.



IMPORTANT



These units are for Indoor Installation only and Only in locations Not Accessible to the General Public.

FAN COIL UNIT

The installer must adhere strictly to all local and national code requirements pertaining to the installation of this equipment. These units are designed to be installed in a vertical, up flow position either hung on a wall or set on a platform within an equipment closet.



WARNING



Extreme caution must be taken that no internal damage will result if screws or holes are drilled into cabinet.

All fan coil units are U.L. Listed for installation with zero inches clearance to combustible materials. This includes the fan coil cabinet, discharge plenum and connecting ducts

Select a location that will provide adequate space to mount the unit and accommodate ducting. The recommended clearance for service is 24". Units with or without electric heat may be installed with 0" clearance to combustibles. Always check the unit rating plate for clearance and other information before mounting unit. Refer to dimensional data in FIGURE #* for units and enclosures to determine space required for mounting.

Sufficient clearance must be provided at the front of the fan coil to allow access to the air filter, electrical controls and removal of the motor/blower assembly for servicing. This clearance distance should be approximately the same as the depth of the fan coil unit.

The unit should be leveled in such a way that there is slope toward the condensate drain nipple to assure positive drainage.



NOTE



It is important at this point to consider noise and vibration. If this installation is in a noise sensitive area then placement of resilient isolators or other means of sound deadening may be necessary

These fan coil units are designed for quiet operation, however, all air conditioning equipment will transfer some amount of noise to the conditioned space. This should be taken into consideration when planning the location of the equipment as well.

AIR DISTRIBUTION DUCTS

All duct work must be installed in accordance with National Fire Protection Association Codes 90A and 90B. Ducts should be adequately insulated to prevent condensation during the cooling cycle and to minimize heat loss during the heating cycle. Provision for connecting the return air duct is located on the side of the unit. The installer must cut out the center section and bend the 3/4" flanges out. The backing insulation must also be removed. See illustration p.3. Duct sizing for unique arrangements or long duct runs must be confirmed by a local professional. The manufacturer will not be responsible for misapplied equipment

STATIC RESSURE

The total external static pressure must be considered when planning duct design and installation. Refer to the rating label on you unit for more information. Units are recommended for use up to 0.5" total external static pressure. A unit operating at lower total external static pressure will be more efficient and quiet vs. operation at higher static pressure.



IMPORTANT



Do not restrict supply air by using a vertical duct with dimensions smaller than the supply air flanges.



IMPORTANT



Do not operate this unit in any mode during building construction due to excessive airborne dust and debris. Do not operate this unit without an air filter in place. The manufacturer does not warrant equipment subjected to abuse.

ELECTRICAL



IMPORTANT



Electrical work associated with the installation of this appliance must comply with the National Electrical Code (NEC). Other local or regional electrical and building code requirements may apply.
In Canada electrical work associated with the installation of this appliance must comply with CE CSA C22.



WARNING



ELECTRIC SHOCK HAZARD



HACR type breakers are recommended. Other over-current protection devices that comply with all applicable codes are acceptable.

Field installed electrical wiring supplying power to this unit and / or electric heaters must include a disconnect device at the unit.

All wiring must comply with local and national code requirements. Units are provided with wiring diagrams and nameplate data to provide information required for necessary field wiring. Knockouts are provided on the cabinet for connection of power supply.

These units are provided with a Class 2 transformer for 24-volt control circuits. Should any add-on equipment also have a Class 2 transformer furnished, care must be taken to prevent interconnecting outputs of the two transformers by using a thermostat with isolating contacts.



WARNING



ELECTRIC SHOCK HAZARD



Means of disconnection must be incorporated in the fixed wiring in accordance with the wiring rules.

MOUNTING

It is important to ensure that the fan coil is securely mounted and the structure is sufficient to support the weight of the equipment. All anchors for mounting the equipment must be placed and sized to ensure a safe and durable installation.

COOLING COIL PIPING

IMPORTANT

It is illegal to discharge refrigerant into the atmosphere. Use proper reclaiming methods and equipment when installing or servicing this unit. Service should be performed by a QUALIFIED service agency. A sealed refrigerant system normally requires no maintenance since it is a closed, self-contained system.¹

WARNING

Failure to follow this warning could result in personal injury or death. Recover all refrigerant before attempting a sealed air conditioning system repair. Recover all refrigerant before final unit disposal. Use all service ports and position all refrigerant flow-control devices open, including expansion valves and solenoid valves.

This fan coil unit is supplied with a direct expansion refrigerant coil. The suction and liquid refrigerant lines must be sized in accordance with the outdoor unit manufacturer's recommendations.

Condensate drain lines must be installed with adequate slope away from the unit to assure positive drainage. Since the drain pan is located on the suction side of the blower, a negative pressure exists at the drain pan and a minimum trap of 1-1/2 inches must be provided in the drain line to assure proper drainage.

NOTE

If a Condensate Overflow Shut-off Switch, that is designed to be installed in the drain line, is used in place of a secondary drain line, then the cut-off switch should be located in the primary drain line between the fan coil unit and the P-trap.

WARNING

FIRE OR EXPLOSION HAZARD

Failure to following this warning could result in personal injury, death and/or property damage. Do not use flames or any potential ignition sources to leak check refrigerant tubing or components.

REFRIGERANT CHARGING

Use adequate personal protection equipment when handling refrigerant including, but not limited to eye and hand protection. Consult the outdoor unit manufacturer's instructions for refrigerant charging and consider all pertinent factors when determining the method of charging, the type and amount of refrigerant required; indoor and outdoor temperatures and humidity, the factory charge amount of the outdoor unit, the length and diameter of tubing between the indoor and outdoor units, the type of metering device installed.

PARTIAL SYSTEM CHARGING



Follow the outdoor unit manufacturer's instructions for adding refrigerant to a partially charged system.

CAUTION

It is highly recommended that a condensate overflow switch be installed to prevent damage which may result from an overflow of the condensate pan.

HOT WATER COIL PIPING PRECAUTIONS

1. Flush all field piping prior to connection to remove all debris.
2. Use wet cotton rags to cool valve bodies when soldering.
3. Open all valves (mid-way for hand valves, manually open on motorized valves) prior to soldering.
4. When soldering to bronze or brass, heat the piping while in the socket/cup and begin introducing the solder when the flux boils rapidly. Avoid direct flame into the solder joint.
5. Heat can only be applied to the cup of the valve body for a minimal time before damage occurs (even with the use of wet rags).
6. Avoid rapid quenching of solder joints as this will produce joints of inferior quality
7. Provisions must be made for expansion and contraction of piping systems. All horizontal and vertical risers, including runouts, must be able to withstand significant movement with temperature changes. Failure to do so will result in damage and failure of piping, fittings and valves throughout the building.
8. All piping made in the field should be installed with consideration of additional space for any electrical routing that may be required.
9. Connect all piping per accepted industry standards and observe all regulations governing installation of piping systems.

	WARNING	
SCALDING HAZARD		
Hot water can cause scalding. If a hot water coil is connected to domestic potable water, a hot water mixing valve can be applied to the system to temper domestic water draw.		

	CAUTION	
Hydronic systems are not designed to hold pressurized air and should only be tested with water. Pressurizing system with air could damage equipment.		





LEAK CHECK

After pipe installation perform a leak check to ensure that no leakage of refrigerants will occur. Use nitrogen to pressure test at a minimum of 200 psig. Pressure must not decrease within 1 hour. Care must be taken to not use any leak detectors which may cause corrosion on the copper tubing.

Evacuate the suction and liquid lines at the outdoor unit service valves to 500 microns. Isolate the vacuum pump from the piping. The vacuum must not exceed 1500 microns in 10 minutes.

- Energize the fan(s) of the appliance to deliver indoor airflow at or above the minimum airflow.
- Disable the compressor.

REFRIGERANT CHARGING

	WARNING	
	FIRE OR EXPLOSION HAZARD	
Failure to following this warning could result in personal injury, death and/or property damage.		
Do not use flames or any potential ignition sources to leak check refrigerant tubing or components.		

	IMPORTANT	
Any metering device installed in the refrigerant circuit must be compatible with the refrigerant used.		

Use adequate personal protection equipment when handling refrigerant including, but not limited to eye and hand protection. Consult the outdoor unit manufacturer's instructions for refrigerant charging and consider all pertinent factors when determining the method of charging and the amount of refrigerant required; indoor and outdoor temperatures and humidity, the factory charge amount of the outdoor unit, the length and diameter of tubing between the indoor and outdoor units, the type of metering device installed.

REFRIGERANT CHARGING



WARNING



- Explosion risk, recover refrigerant only in a cylinder designed and intended for this purpose
- Do not use a damaged cylinder
- Do not apply flame or excessive heat to a refrigerant cylinder
- Do not fill a refrigerant cylinder to more than 80% of its capacity
- Do not use a refrigerant cylinder for anything other than its designed and intended purpose
- Do not use an expired refrigerant cylinder
- Use recovery equipment designed to handle the refrigerant being recovered
- Earth-ground refrigerant cylinders before using



WARNING



IMPROPER HANDLING OF REFRIGERANTS CAN CAUSE INJURY, EXPLOSION AND DEATH

- It is illegal to release refrigerant into the atmosphere. Refrigerant released into an enclosed space will displace oxygen causing unconsciousness and death.
- If an indoor refrigerant leak is suspected, thoroughly ventilate the area before beginning any work
- DO NOT purge or allow refrigerant to be released into an interior space
- Contact with liquid refrigerant can cause frostbite and blindness. Avoid skin contact with liquid refrigerant, wear goggles and gloves when working with refrigerants. Seek medical help immediately if any refrigerant contact with skin or eyes occurs
- Never burn refrigerant as highly toxic gas will be produced
- Only EPA certified technicians should handle refrigerants.
- In Canada technicians must be ODP / ODS certified to handle refrigerants
- Follow all EPA regulations



WARNING



It is illegal to discharge refrigerant into the atmosphere. Use proper reclaiming methods and equipment when installing or servicing this unit. A QUALIFIED service agency should perform this service.

Follow the outdoor unit manufacturer's instructions for adding refrigerant to a partially charged system.

FLAMMABLE REFRIGERANT LEAK DETECTION

Under no circumstances should potential sources of ignition be used for detecting refrigerant leaks. Devices such as halide torches (or other detectors using a naked flame) are strictly prohibited. Acceptable methods for refrigerant leak detection include:

- **Electronic Leak Detectors:** These may be used to detect refrigerant leaks; however, for flammable refrigerants, ensure the sensitivity is adequate and the equipment is recalibrated as necessary. Calibration must occur in a refrigerant-free area. The detector must not pose an ignition risk and should be specifically suited for the refrigerant used. Set the detection equipment to a percentage of the refrigerant's Lower Flammability Limit (LFL), with a maximum setting of 25%. Ensure calibration corresponds to the refrigerant employed.
- **Leak Detection Fluids:** Fluids such as the bubble method or fluorescent agents are suitable. Avoid detergents containing chlorine, as these may react with the refrigerant and corrode copper pipework.

Important Note: If a refrigerant leak is suspected, all open flames must be extinguished. For leaks requiring brazing, recover all refrigerant from the system or isolate it using shut-off valves in a remote part of the system. Removal of refrigerant must follow the removal and evacuation procedures.

REFRIGERANT CHARGING CONT.

REFRIGERANT CHARGING INSTRUCTIONS

When charging the system in cooling mode, ensure the outdoor temperature is 60°F or higher. Operate the system for a minimum of 15 minutes between adjustments to allow the pressures to stabilize. Systems equipped with micro-channel outdoor coils require small adjustments of 1 ounce or less, as they are highly sensitive to refrigerant charge.

TXV Charging

1. Refer to the instructions provided with the outdoor unit.
2. Alternatively, for AC units, charge to achieve 12°F sub-cooling. For heat pump units, charge to 10°F sub-cooling.
3. If the system is equipped with an adjustable valve, adjust to achieve 10°F superheat.

Fixed Orifice Charging

1. Use the superheat value recommended in the outdoor unit instructions for A1 (R-410) and A2L (R-454B & R-32) refrigerants.
2. Heat pump units initially charged in cooling mode may require final charge adjustments in heating mode, if necessary. For units requiring charging in heating mode, refer to the outdoor unit instructions.

If the system is undercharged after the initial charge, add refrigerant until the sight glass is clear and the recommended pressures, temperatures, sub-cooling, and superheat are achieved. If the system is overcharged, recover refrigerant until these values are within recommended limits.

ELECTRICAL DATA

ELECTRICAL DATA Q4							
Model Number	Voltage Rating	Motor Amps	Motor HP	Pump Amps	Pump HP	Min. Circuit Ampacity	Max. Overcurrent Protection
24CLPQ4*	120V-1PH-60HZ	4.4	1/4	0.75	1/40	6	15
36CLPQ4*	120V-1PH-60HZ	8.1	1/2	0.75	1/40	11	15
12CLXQ4*	120V-1PH-60HZ	3.5	1/4	0.75	1/40	6	15
24CLXQ4*	120V-1PH-60HZ	6.8	1/2	0.75	1/40	9	15
25CLXQ4*	120V-1PH-60HZ	6.8	1/2	0.75	1/40	9	15
36CLXQ4*	120V-1PH-60HZ	8.4	3/4	0.75	1/40	11	15
37CLXQ4*	120V-1PH-60HZ	8.4	3/4	0.75	1/40	11	15

TABLE 1

ELECTRICAL DATA W4					
Model Number	Voltage Rating	Motor Amps	Motor HP	Min. Circuit Ampacity	Max. Overcurrent Protection
24CLPW4*	120V-1PH-60HZ	4.4	1/4	6	15
12CLXW4*	120V-1PH-60HZ	3.5	1/4	5	15
24CLXW4*	120V-1PH-60HZ	6.8	1/2	9	15
25CLXW4*	120V-1PH-60HZ	6.8	1/2	9	15
36CLXW4*	120V-1PH-60HZ	8.4	3/4	11	15
37CLXW4*	120V-1PH-60HZ	8.4	3/4	11	15

TABLE 2

ELECTRICAL DATA

ELECTRIC HEAT						
Model	Voltage Rating	Motor Amps	Motor HP	Heater L1 - L2	L1 - L2 Min. Circuit Ampacity 208V / 240V	L1 - L2 Max. Overcurrent Protection
24CLP00*	208/230V-1PH-60HZ	1.6	1/6		2	15
24CLP03*	208/230V-1PH-60HZ	1.6	1/6	2.3 kw/208V, 3.0 kw/240V	15 / 18	15 / 20
24CLP04*	208/230V-1PH-60HZ	1.6	1/6	3.0 kw/208V, 4.0 kw/240V	20 / 23	20 / 25
24CLP05*	208/230V-1PH-60HZ	1.6	1/6	3.8 kw/208V, 5.0 kw/240V	25 / 28	25 / 30
24CLP06*	208/230V-1PH-60HZ	1.6	1/6	4.5 kw/208V, 6.0 kw/240V	29 / 33	30 / 35
24CLP08*	208/230V-1PH-60HZ	1.6	1/6	6.0 kw/208V, 8.0 kw/240V	38 / 44	40 / 45
24CLP10	208/230V-1PH-60HZ	1.6	1/6	7.5 kw/208V, 10.0 kw/240V	47 / 54	50 / 60
36CLP00*	208/230V-1PH-60HZ	2.5	1/3		3	15
36CLP02*	208/230V-1PH-60HZ	2.5	1/3	1.5 kw/208V, 2.0 kw/240V	12 / 14	15 / 15
36CLP04*	208/230V-1PH-60HZ	2.5	1/3	3.0 kw/208V, 4.0 kw/240V	21 / 24	25 / 25
36CLP05*	208/230V-1PH-60HZ	2.5	1/3	3.8 kw/208V, 5.0 kw/240V	26 / 29	30 / 30
36CLP06*	208/230V-1PH-60HZ	2.5	1/3	4.5 kw/208V, 6.0 kw/240V	30 / 35	30 / 35
36CLP08*	208/230V-1PH-60HZ	2.5	1/3	6.0 kw/208V, 8.0 kw/240V	39 / 45	40 / 45
36CLP10*	208/230V-1PH-60HZ	2.5	1/3	7.5 kw/208V, 10.0 kw/240V	48 / 55	50 / 60
12CLX00*	120V-1PH-60HZ	3.5	1/4		2	15
12CLX03*	120V-1PH-60HZ	3.5	1/4	3.0 kw/120V	36	40
12CLX05*	120V-1PH-60HZ	3.5	1/4	5.0 kw/120V	57	60
24CLX00*	208/230V-1PH-60HZ	2.8	1/3		3	15
24CLX03*	208/230V-1PH-60HZ	2.8	1/3	2.3 kw/208V, 3.0 kw/240V	17 / 19	20 / 20
24CLX04*	208/230V-1PH-60HZ	2.8	1/3	3.0 kw/208V, 4.0 kw/240V	22 / 24	25 / 25
24CLX05*	208/230V-1PH-60HZ	2.8	1/3	3.8 kw/208V, 5.0 kw/240V	26 / 30	30 / 30
24CLX06*	208/230V-1PH-60HZ	2.8	1/3	4.5 kw/208V, 6.0 kw/240V	31 / 35	35 / 35
24CLX08*	208/230V-1PH-60HZ	2.8	1/3	6.0 kw/208V, 8.0 kw/240V	40 / 45	40 / 45
24CLX10*	208/230V-1PH-60HZ	2.8	1/3	7.5 kw/208V, 10.0 kw/240V	49 / 56	50 / 60
25CLX00*	208/230V-1PH-60HZ	2.8	1/3		3	15
25CLX03*	208/230V-1PH-60HZ	2.8	1/3	2.3 kw/208V, 3.0 kw/240V	17 / 19	20 / 20
25CLX04*	208/230V-1PH-60HZ	2.8	1/3	3.0 kw/208V, 4.0 kw/240V	22 / 24	25 / 25
25CLX05*	208/230V-1PH-60HZ	2.8	1/3	3.8 kw/208V, 5.0 kw/240V	26 / 30	30 / 30
25CLX06*	208/230V-1PH-60HZ	2.8	1/3	4.5 kw/208V, 6.0 kw/240V	31 / 35	35 / 35
25CLX08*	208/230V-1PH-60HZ	2.8	1/3	6.0 kw/208V, 8.0 kw/240V	40 / 45	40 / 45
25CLX10*	208/230V-1PH-60HZ	2.8	1/3	7.5 kw/208V, 10.0 kw/240V	49 / 56	50 / 60
36CLX00*	208/230V-1PH-60HZ	4.1	1/2		4	15
36CLX03*	208/230V-1PH-60HZ	4.1	1/2	2.3 kw/208V, 3.0 kw/240V	19 / 21	20 / 25
36CLX05*	208/230V-1PH-60HZ	4.1	1/2	3.8 kw/208V, 5.0 kw/240V	28 / 31	30 / 35
36CLX06*	208/230V-1PH-60HZ	4.1	1/2	4.5 kw/208V, 6.0 kw/240V	32 / 36	35 / 40
36CLX08*	208/230V-1PH-60HZ	4.1	1/2	6.0 kw/208V, 8.0 kw/240V	41 / 47	45 / 50
36CLX10*	208/230V-1PH-60HZ	4.1	1/2	7.5 kw/208V, 10.0 kw/240V	50 / 57	50 / 60
37CLX00*	208/230V-1PH-60HZ	4.1	1/2		4	15
37CLX05*	208/230V-1PH-60HZ	4.1	1/2	3.8 kw/208V, 5.0 kw/240V	28 / 31	30 / 35
37CLX06*	208/230V-1PH-60HZ	4.1	1/2	4.5 kw/208V, 6.0 kw/240V	32 / 36	35 / 40
37CLX08*	208/230V-1PH-60HZ	4.1	1/2	6.0 kw/208V, 8.0 kw/240V	41 / 47	45 / 50
37CLX10*	208/230V-1PH-60HZ	4.1	1/2	7.5 kw/208V, 10.0 kw/240V	50 / 57	50 / 60

TABLE 3

OPERATION AND MAINTENANCE

WARNING

FIRE OR EXPLOSION HAZARD

Failure to following this warning could result in personal injury, death and/or property damage. Do not attempt any sealed system repair without first recovering the entire refrigerant charge. Refrigerant and oil mixture could ignite in the presence of a brazing torch flame. Completely recover the refrigerant charge using both the high and low sides of the system and purge the sealed system with nitrogen before brazing any component or tubing.

WARNING

FIRE OR EXPLOSION HAZARD

Do not mix refrigerant with air for leak testing or other purposes.

WARNING

ELECTRIC SHOCK HAZARD

Electrically ground the fan coil. Connect the ground wire to the terminal marked with the ground symbol, . Failure to properly ground the unit could result in injury or death. Always disconnect power before servicing and verify power is off to prevent accidental shock.

CAUTION

Devices such as fan switches or thermostats provided for field installation must be wired according to the supplied wiring diagram. Failure to do so could result in damage to components and void the warranty.

PRE-START CHECK

Before starting the unit:

1. Ensure supply voltage matches the nameplate data.
2. Verify the unit is properly grounded.
3. Check blower wheel set screws for tightness and ensure blower wheels rotate freely and quietly.
4. Ensure the fan coil is securely installed and sloped toward the drain line.
5. Verify the condensate line is properly sized, run, trapped, pitched, and tested.
6. Ensure a clean filter is installed and access panels are secured.

7. Check that refrigerant coil connections and piping are leak-free and properly insulated.
8. Seal any knockouts, penetrations, or exposed holes to maintain low air leakage.

WARNING

ELECTRIC SHOCK HAZARD

Disconnect all power supplies before servicing. Lockout/tagout to prevent accidental shock. Ensure all personal protective equipment is worn when servicing or maintaining the unit.

START-UP AND MAINTENANCE

Before start-up, perform the following checks:

- Clean all components of debris to prevent operational issues.
- Ensure all access panels and filters are properly installed.
- Verify unit cleanliness and secure all rotating components.

FAN

Inspect and clean the fan annually in conjunction with motor and bearing maintenance. Keep wheels clean to avoid imbalance and vibration.

MOTOR

Check motor connections for security and compliance with wiring diagrams. For ECM motors, ensure power is disconnected before servicing, as line voltage is always present.

FILTER

Replace or clean the air filter every 30 days or more frequently under severe conditions. Use the same type as originally furnished.

COIL

Clean dust or contaminants from heat transfer surfaces using one of the following methods:

- Low-pressure compressed air.
- Flushing with water (use a detergent for greasy surfaces).

DRAIN PIPING

Ensure the drain is:

- Properly connected and sloped away from the unit (1/8 inch per foot minimum).
- Checked before summer operation and periodically during operation.

OPERATION & MAINTENANCE CONTINUED

PUMP REPLACEMENT

Disconnect electrical power before servicing the unit.

To replace the circulator pump, close the isolation valves and relieve the water pressure within the heating loop. Disconnect the pump's 115 volt power lines within the control box and remove the four hex head screws securing the pump motor to the pump's volute.

Reverse the above steps for reassembling the pump, however make sure that the pump or volute has the rubber O-ring in place before assembling.

CHECK VALVE REPLACEMENT

Disconnect electrical power before servicing the unit.

To replace the internal check valve, close the isolation valves and relieve the water pressure within the heating loop. Remove the four hex head screws securing the pump motor to the pumps volute and remove. The check valve is located in the volute. Rotate the check valve to release and remove from volute.

Reverse the above steps for reinstalling at check valve, however make sure that the pump or volute has the rubber O-ring in place before assembling.

LABORATORY TESTING

When the unit has less than 100 operational hours and the coils have not had sufficient time to be "seasoned", it is necessary to clean the coils with mild surfactant such as Calgon to remove the oils left by manufacturing processes.

REFRIGERANT DETECTION SENSOR (RDS) INFORMATION

For equipment utilizing A2L refrigerants, a Refrigerant Detection System (RDS) is installed on this unit to detect any A2L refrigerant leakage in the coil and internal refrigerant containing components and will take action to mitigate any risk of ignition / fire.

Refer to the appliance IOM for information regarding the minimum conditioned room requirements, and instructions for the RDS operation, installation, and wiring. Any field installed wiring connected to the RDS must be at least 18AWG and have minimum insulation thickness of 1.58mm or be protected from damage.

The RDS is not intended for service or repair. In the event of a sensor failure, the mitigation mode will

engage and the sensor shall be replaced by removing the sensor and replacing it with a new sensor.

False ceilings or drop ceilings may be used as a return air plenum if a refrigerant detection system is provided in the appliance and any external connections are also provided with a sensor immediately below the return air plenum duct joint.

QUALIFICATION OF WORKERS

Service shall only be performed by qualified technicians, certified by national training organizations or manufacturers that are accredited to teach the relevant national competency standards that may be set in legislation. Competence to properly service the appliance should be documented by a certificate.

CHECKS TO THE WORK AREA

Prior to beginning work on the appliance, safety checks are necessary to ensure that the risk of ignition of released gasses is minimized. Work shall be undertaken under a controlled procedure so as to minimize the risk of a flammable gas or vapor being present while the work is being performed.

All maintenance staff and others working in the local area shall be instructed on the nature of work being carried out. Work in confined spaces shall be avoided.

CHECKING FOR PRESENCE OF REFRIGERANT

The area shall be checked with an appropriate refrigerant detector prior to and during work, to ensure the technician is aware of potentially toxic or flammable atmospheres. Ensure that the leak detection equipment being used is suitable for use with all applicable refrigerants, i.e. non-sparking, adequately sealed or intrinsically safe.

If any hot work is to be conducted on the refrigerating equipment or any associated parts, appropriate fire extinguishing equipment shall be available to hand. Have a dry powder or CO2 fire extinguisher adjacent to the charging area.

No person carrying out work in relation to a REFRIGERATING SYSTEM which involves exposing any such a pipe work shall use any sources of ignition in a manner that it may lead to the risk of fire or explosion.

OPERATION & MAINTENANCE CONTINUED

All possible ignition sources, including cigarette smoking, should be kept sufficiently far away from the site of installation, repairing, removing and disposal, during which refrigerant can possibly be released to the surrounding space. Prior to work taking place, the area around the equipment is to be surveyed to make sure that there are no flammable hazards or ignition risks. "NO SMOKING" signs shall be displayed.

VENTILATED AREA

Ensure that the area is in the open or that it is adequately ventilated before breaking into the system or conducting any hot work. A degree of ventilation shall continue during the period that the work is carried out. The ventilation should safely disperse any released refrigerant and preferably expel it externally into the atmosphere.

CHECKS TO THE REFRIGERATING EQUIPMENT

Where electrical components are being changed, they shall be fit for the purpose and to the correct specification. At all times the manufacturer's maintenance and service guidelines shall be followed. If in doubt, consult the manufacturer's technical department for assistance.

The following checks shall be applied to installations using FLAMMABLE REFRIGERANTS:

- The actual REFRIGERANT CHARGE is in accordance with the room size within which the refrigerant containing parts are installed;
- The ventilation machinery and outlets are operating adequately and are not obstructed;
- Marking to the equipment continues to be visible and legible. Markings and signs that are illegible shall be corrected;
- Refrigerating pipe or components are installed in a position where they are unlikely to be exposed to any substance which may corrode refrigerant containing components, unless the components are constructed of materials which are inherently resistant to being corroded or are suitably protected against being so corroded.

CHECKS TO ELECTRICAL DEVICES AND SEALED ELECTRICAL COMPONENTS

Repair and maintenance to electrical components shall include initial safety checks and component inspection procedures. If a fault exists that could compromise safety, then no electrical supply shall be connected to the circuit until it is satisfactorily dealt with. If the fault cannot be corrected immediately but it is necessary to continue operation, an adequate temporary solution shall be used. This shall be reported to the owner of the equipment so all parties are advised.

Initial Safety Checks shall include:

- That capacitors are discharged: this shall be done in a safe manner to avoid possibility of sparking;
- That no live electrical components and wiring are exposed while charging, recovering or purging the system;
- That there is continuity of earth bonding.

Sealed electrical components shall be replaced in the event of damage or malfunction.

FLAMMABLE REFRIGERANT LEAK DETECTION

Under no circumstances should potential sources of ignition be used for detecting refrigerant leaks. Devices such as halide torches (or other detectors using a naked flame) are strictly prohibited. Acceptable methods for refrigerant leak detection include:

- **Electronic Leak Detectors:** These may be used to detect refrigerant leaks; however, for flammable refrigerants, ensure the sensitivity is adequate and the equipment is recalibrated as necessary. Calibration must occur in a refrigerant-free area. The detector must not pose an ignition risk and should be specifically suited for the refrigerant used. Set the detection equipment to a percentage of the refrigerant's Lower Flammability Limit (LFL), with a maximum setting of 25%. Ensure calibration corresponds to the refrigerant employed.
- **Leak Detection Fluids:** Fluids such as the bubble method or fluorescent agents are suitable. Avoid detergents containing chlorine, as these may react with the refrigerant and corrode copper pipework.

Important Note: If a refrigerant leak is suspected, all open flames must be extinguished. For leaks requiring brazing, recover all refrigerant from the system or isolate it using shut-off valves in a remote part of the system. Removal of refrigerant must follow the removal and evacuation procedures.

OPERATION & MAINTENANCE CONTINUED

REMOVAL AND EVACUATION OF FLAMMABLE

REFRIGERANTS

When breaking into the refrigerant circuit to make repairs – or for any other purpose – conventional procedures shall be used. However, for FLAMMABLE REFRIGERANTS it is important that best practice is followed since flammability is a consideration. The following procedure shall be adhered to:

- Remove refrigerant charge following local and national regulations
- Purge the circuit with inert gas (optional for A2L);
- Evacuate (optional for A2L)
- If using flame to open circuit, continuously flush system with an inert gas
- Open the circuit by cutting or brazing.

The refrigerant charge shall be recovered into the correct recovery cylinders if venting is not allowed by local and national codes. For appliances containing flammable refrigerants, the system shall be purged with oxygen-free nitrogen to render the appliance safe for flammable refrigerants. This process might need to be repeated several times. Compressed air or oxygen shall not be used for purging refrigerant systems.

For appliances containing flammable refrigerants, refrigerant purging shall be achieved by breaking the vacuum in the system with oxygen-free nitrogen and continuing until the working pressure is achieved, then venting to the atmosphere, and finally pulling down to a vacuum (optional for A2L). This process shall be repeated until no refrigerant is within the system (optional for A2L). When the final oxygen-free nitrogen charge is used, the system shall be vented down to atmospheric pressure to enable work to take place.

The outlet for the vacuum pump shall not be close to any potential ignition sources, and ventilation shall be available.

CHARGING PROCEDURES

In addition to conventional charging procedures, the following requirements shall be followed.

- Ensure that contamination of different refrigerants does not occur when using charging equipment. Hoses or lines shall be as short as possible to minimize the amount of refrigerant contained in them.
- Cylinders shall be kept in an appropriate position according to the instructions.
- Ensure that the REFRIGERATING SYSTEM is earthed prior to charging the system with refrigerant.
- Label the system when charging is complete (if not already).
- Extreme care shall be taken not to overfill the REFRIGERATING SYSTEM.

Prior to recharging the system, it shall be pressure-tested with the appropriate purging gas. The system shall be leak-tested on completion of charging but prior to commissioning. A follow up leak test shall be carried out prior to leaving the site.

DECOMMISSIONING

Before carrying out this procedure, it is essential that the technician is completely familiar with the equipment and all its detail. It is recommended good practice that all refrigerants are recovered safely. Prior to the task being carried out, an oil and refrigerant sample shall be taken in case analysis is required prior to re-use of recovered refrigerant. It is essential that electrical power is available before the task is commenced.

- A. Become familiar with the equipment and its operation.
- B. Isolate system electrically.
- C. Before attempting the procedure, ensure that:
 - a. mechanical handling equipment is available, if required, for handling refrigerant cylinders;
 - b. all personal protective equipment is available and being used correctly;
 - c. the recovery process is supervised at all times by a competent person;
 - d. recovery equipment and cylinders conform to the appropriate standards.

OPERATION & MAINTENANCE CONTINUED

- A. Pump down refrigerant system, if possible.
- B. If a vacuum is not possible, make a manifold so that refrigerant can be removed from various parts of the system.
- C. Make sure that cylinder is situated on the scales before recovery takes place.
- D. Start the recovery machine and operate in accordance with instructions.
- E. Do not overfill cylinders (no more than 80 % volume liquid charge).
- F. Do not exceed the maximum working pressure of the cylinder, even temporarily.
- G. When the cylinders have been filled correctly and the process completed, make sure that the cylinders and the equipment are removed from site promptly and all isolation valves on the equipment are closed off.
- H. Recovered refrigerant shall not be charged into another REFRIGERATING SYSTEM unless it has been cleaned and checked.

LABELING

Equipment shall be labelled stating that it has been de-commissioned and emptied of refrigerant. The label shall be dated and signed. For appliances containing FLAMMABLE REFRIGERANTS, ensure that there are labels on the equipment stating that the equipment contains FLAMMABLE REFRIGERANT.

RECOVERY

When removing refrigerant from a system, either for servicing or commissioning, it is recommended good practice that all refrigerants are removed safely.

When transferring refrigerant into cylinders, ensure that only appropriate refrigerant recovery cylinders are employed. Ensure that the correct number of cylinders for holding the total system charge is available. All cylinders to be used are designated for the recovered refrigerant and labelled for that refrigerant (i.e. special cylinders for the recovery of refrigerant). Cylinders shall be complete with pressure-relief valve and associated shut-off valves in good working order. Empty recovery cylinders are evacuated and, if possible, cooled before recovery occurs.

The recovery equipment shall be in good working order with a set of instructions concerning the equipment that is at hand and shall be suitable for the recovery of the flammable refrigerant. If in doubt, the manufacturer should be consulted. In addition, a set of calibrated weighing scales shall be available and in good working order. Hoses shall be complete with leak-free disconnect couplings and in good condition.

The recovered refrigerant shall be processed according to local Legislation in the correct recovery cylinder, and the relevant waste transfer note arranged. Do not mix refrigerants in recovery units and especially not in cylinders.

If compressors or compressor oils are to be removed, ensure that they have been evacuated to an acceptable level to make certain that flammable refrigerant does not remain within the lubricant. The compressor body shall not be heated by an open flame or other ignition sources to accelerate this process. When oil is drained from a system, it shall be carried out safely.

OPERATION & MAINTENANCE CONTINUED

Status Light Table for Refrigerant Detection System (RDS)		
Status Light	State / Condition	System Response
Green Blinking	Normal Operation	<ul style="list-style-type: none"> - The system is actively monitoring refrigerant levels. - No refrigerant detected above the activation threshold. - Outdoor unit compressor and indoor blower operate normally.
Red Continuous	Refrigerant Leak Detected	<ul style="list-style-type: none"> - Refrigerant concentration exceeds the activation threshold. - The outdoor unit compressor (Y) is turned off to prevent further circulation of refrigerant. - The indoor blower is turned on to recirculate air and mitigate the refrigerant concentration.
Red Blinking	Fault Detected	<ul style="list-style-type: none"> - A fault in the refrigerant detection system (e.g., calibration issue, end-of-life) has been detected. - The outdoor unit compressor (Y) and indoor blower mitigation mode are deactivated for safety. - System requires inspection or replacement.
No Light	System Off or Malfunction	<ul style="list-style-type: none"> - The system is not operational. - Check the power supply and all system connections.
Amber Blinking	System Initializing	<ul style="list-style-type: none"> - The system is warming up after power-up. - The outdoor unit compressor (Y) and indoor blower mitigation mode remain inactive during this phase. - Transitions to green blinking when monitoring begins.

TABLE 4

A2L SENSING AND MITIGATION

Air handler units that can be charged with over 4lbs (1.81kg) of R454B or R32 refrigerant are shipped with a factory installed refrigerant leak detector attached near the bottom of the evaporator coil. In the event that a refrigerant leak is detected, the controls will disable the compressor operation, and energize the evaporator fan to disperse the leaked refrigerant. The unit will operate in this mitigation state until the sensor no longer detects a refrigerant leak, for a minimum time of 5 minutes. Once the mitigation period has ended, the unit will return to its normal operation based on the current thermostat inputs. An LED status light is provided with the sensor for diagnostic purposes, the description of the LED status light signals can be found in the following table.

OPERATION AND MAINTENANCE CONTINUED

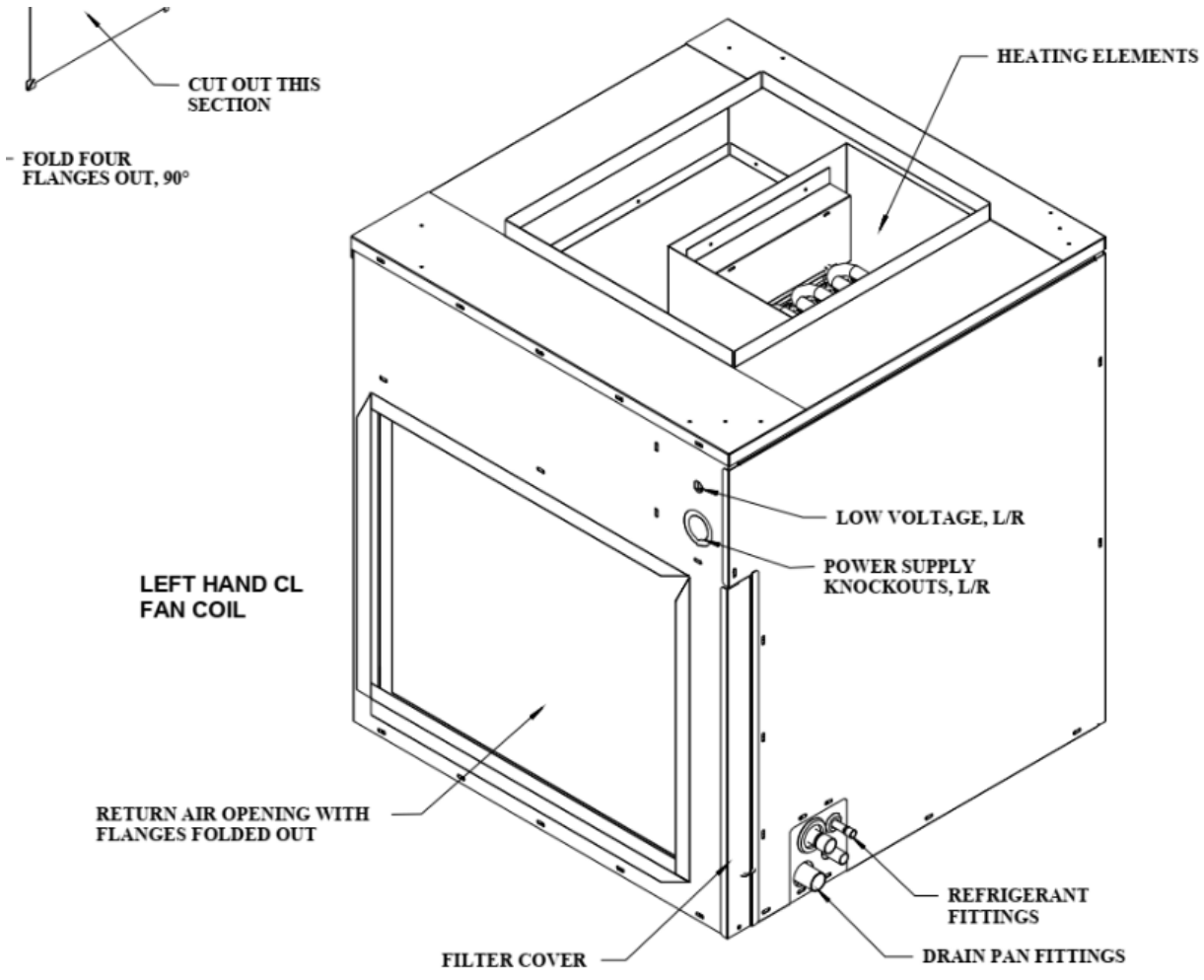
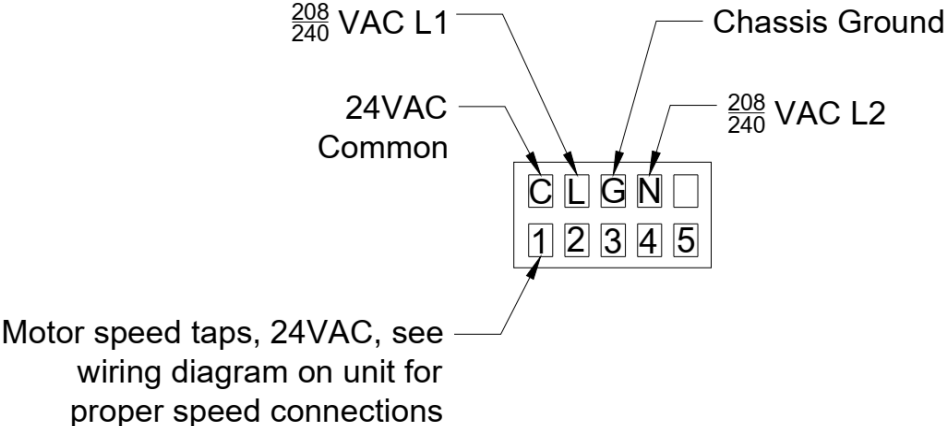

Figure 1

OPERATION AND MAINTENANCE CONTINUED



BRUSHLESS DC MOTOR CONNECTIONS
IF SO EQUIPPED
SEE WIRING DIAGRAM

Figure 2

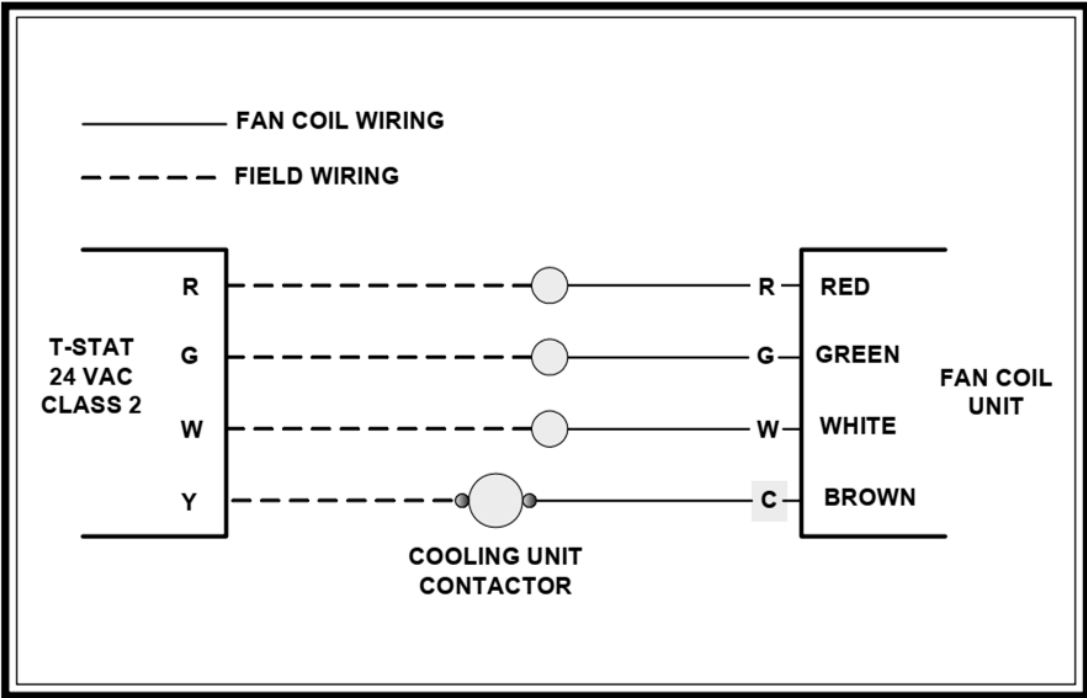

Figure 3

OPERATION AND MAINTENANCE CONTINUED

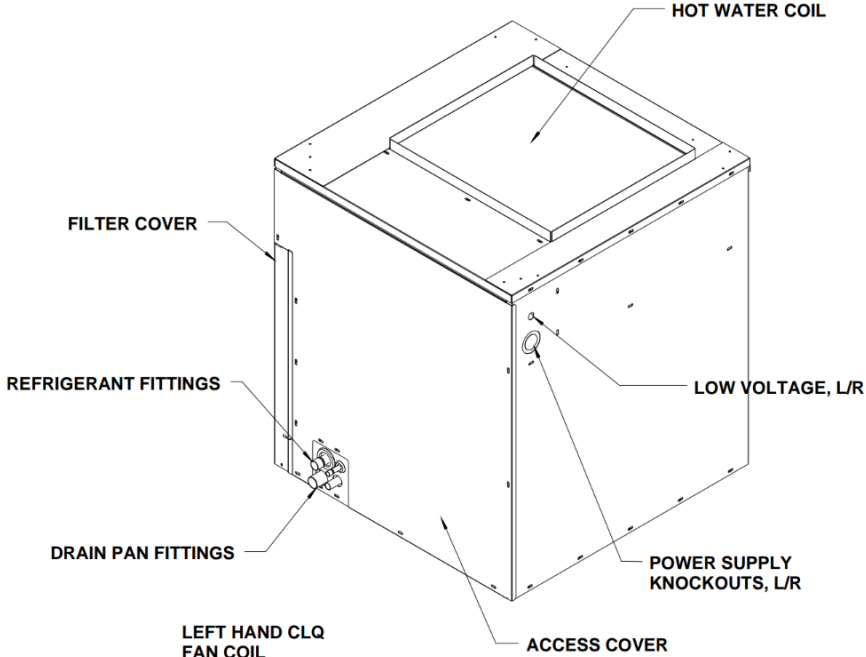

Figure 4

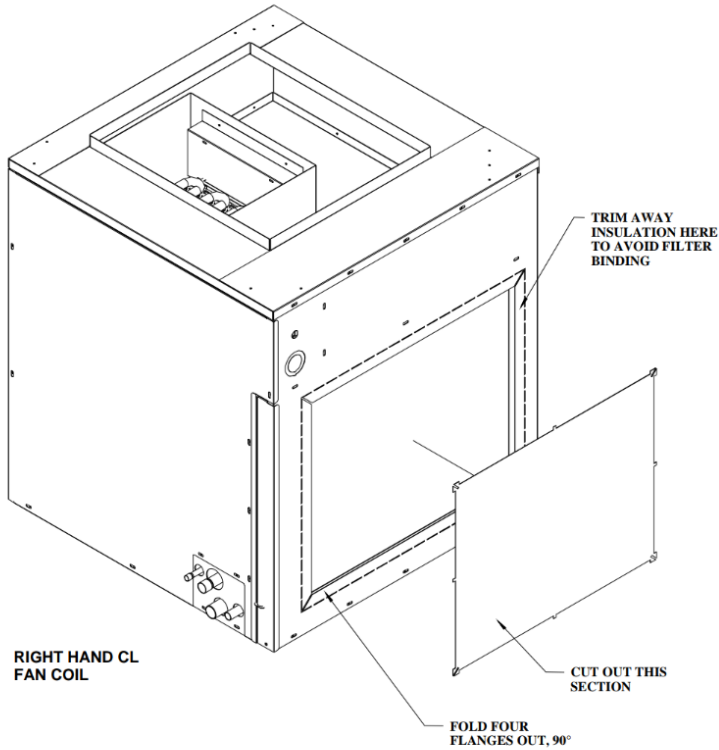

Figure 5

OPERATION AND MAINTENANCE CONTINUED

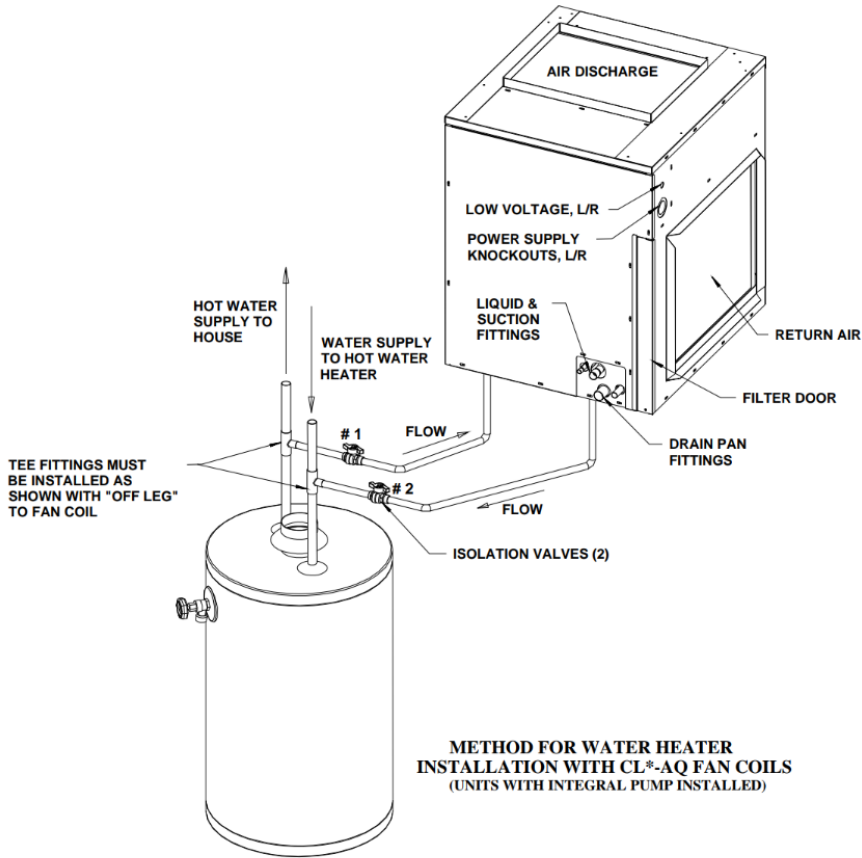
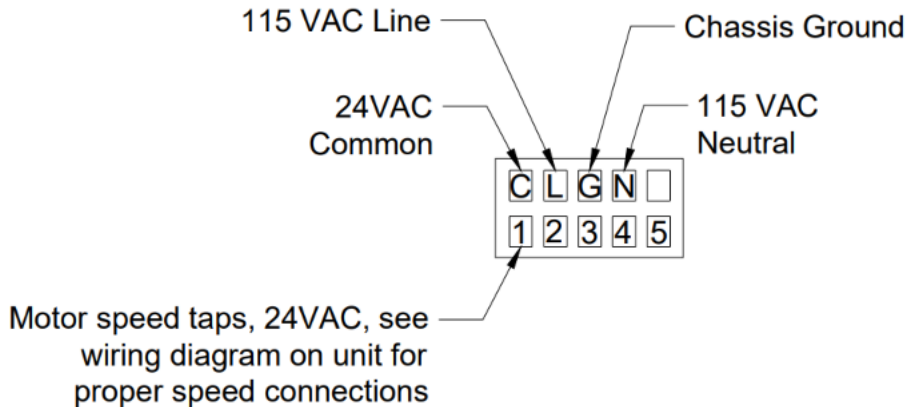

Figure 6



BRUSHLESS DC MOTOR CONNECTIONS

Figure 7

MINIMUM ROOM SIZE AND MITIGATION AIRFLOW

These fan-coils are compatible with A1 as well as A2L refrigerants. However, additional critical components are required if they are used with A2L refrigerants. If not already pre-configured for A2L refrigerants from the factory a kit that is designed for a particular refrigerant must be field installed to ensure that any leakage of refrigerant is sensed and automatically mitigated.

Additionally, units charged with A2L refrigerants require a minimum room size for the application of the fan-coil as well as a minimum mitigation airflow. Both of these are determined as a function of the total refrigerant charge. The total charge is determined by the charge in the outdoor unit (see outdoor nameplate) plus the charge that was added to the system upon installation.

Minimum Circulation Airflow and Room Area for a Given Charge of R32											
System Charge of R32		Min Circulation Airflow		Minimum Room Area							
				1.8 m (6 ft) Ceiling/Release Height		2.4 m (8 ft) Ceiling/Release Height		3 m (10 ft) Ceiling/Release Height		3.6 m (12 ft) Ceiling/Release Height	
kg	lbs	m ³ /hr	CFM	m ²	ft ²	m ²	ft ²	m ²	ft ²	m ²	ft ²
1.8	4	178	105	6.6	71	4.9	53	4	43	3.3	35
2.3	5	222	131	8.2	89	6.2	66	4.9	53	4.1	44
2.7	6	267	157	9.9	106	7.4	80	5.9	64	4.9	53
3.2	7	311	183	11.5	124	8.6	93	6.9	74	5.8	62
3.6	8	356	209	13.2	142	9.9	106	7.9	85	6.6	71
4.1	9	400	236	14.8	159	11.1	120	8.9	96	7.4	80
4.5	10	445	262	16.5	177	12.4	133	9.9	106	8.2	89
5	11	489	288	18.1	195	13.6	146	10.9	117	9.1	97
5.4	12	534	314	19.8	213	14.8	159	11.9	128	9.9	106
5.9	13	578	340	21.4	230	16.1	173	12.8	138	10.7	115
6.3	14	622	366	23.1	248	17.3	186	13.8	149	11.5	124
6.8	15	667	393	24.7	266	18.5	199	14.8	159	12.4	133
7.3	16	711	419	26.3	284	19.8	213	15.8	170	13.2	142
7.7	17	756	445	28	301	21	226	16.8	181	14	151
8.2	18	800	471	29.6	319	22.2	239	17.8	191	14.8	159
8.6	19	845	497	31.3	337	23.5	252	18.8	202	15.6	168
9.1	20	889	523	32.9	354	24.7	266	19.8	213	16.5	177
9.5	21	934	550	34.6	372	25.9	279	20.7	223	17.3	186
10	22	978	576	36.2	390	27.2	292	21.7	234	18.1	195
10.4	23	1023	602	37.9	408	28.4	306	22.7	245	18.9	204
10.9	24	1067	628	39.5	425	29.6	319	23.7	255	19.8	213
11.3	25	1112	654	41.2	443	30.9	332	24.7	266	20.6	221
11.8	26	1156	680	42.8	461	32.1	346	25.7	276	21.4	230
12.2	27	1200	707	44.5	478	33.3	359	26.7	287	22.2	239
12.7	28	1245	733	46.1	496	34.6	372	27.7	298	23.1	248
13.2	29	1289	759	47.8	514	35.8	385	28.7	308	23.9	257
13.6	30	1334	785	49.4	532	37.1	399	29.6	319	24.7	266

Table 5

MINIMUM ROOM SIZE AND MITIGATION AIRFLOW CONTINUED

Minimum Circulation Airflow and Room Area for a Given Charge of R454B											
System charge of R454B		Min Circulation Airflow		Minimum Room Area							
				1.8 m (6 ft) Ceiling/Release Height		2.4 m (8 ft) Ceiling/Release Height		3 m (10 ft) Ceiling/Release Height		3.6 m (12 ft) Ceiling/Release Height	
kg	lbs	m ³ /hr	CFM	m ²	ft ²	m ²	ft ²	m ²	ft ²	m ²	ft ²
1.8	4	184	108	6.8	73	5.1	55	4.1	44	3.4	37
2.3	5	230	135	8.5	92	6.4	69	5.1	55	4.3	46
2.7	6	276	162	10.2	110	7.7	82	6.1	66	5.1	55
3.2	7	322	189	11.9	128	8.9	96	7.2	77	6	64
3.6	8	368	216	13.6	147	10.2	110	8.2	88	6.8	73
4.1	9	414	243	15.3	165	11.5	124	9.2	99	7.7	82
4.5	10	460	271	17	183	12.8	137	10.2	110	8.5	92
5	11	506	298	18.7	201	14	151	11.2	121	9.4	101
5.4	12	552	325	20.4	220	15.3	165	12.3	132	10.2	110
5.9	13	598	352	22.1	238	16.6	179	13.3	143	11.1	119
6.3	14	644	379	23.8	256	17.9	192	14.3	154	11.9	128
6.8	15	689	406	25.5	275	19.2	206	15.3	165	12.8	137
7.3	16	735	433	27.2	293	20.4	220	16.3	176	13.6	147
7.7	17	781	460	28.9	311	21.7	234	17.4	187	14.5	156
8.2	18	827	487	30.6	330	23	247	18.4	198	15.3	165
8.6	19	873	514	32.3	348	24.3	261	19.4	209	16.2	174
9.1	20	919	541	34	366	25.5	275	20.4	220	17	183
9.5	21	965	568	35.8	385	26.8	289	21.5	231	17.9	192
10	22	1011	595	37.5	403	28.1	302	22.5	242	18.7	201
10.4	23	1057	622	39.2	421	29.4	316	23.5	253	19.6	211
10.9	24	1103	649	40.9	440	30.6	330	24.5	264	20.4	220
11.3	25	1149	676	42.6	458	31.9	343	25.5	275	21.3	229
11.8	26	1195	703	44.3	476	33.2	357	26.6	286	22.1	238
12.2	27	1241	730	46	495	34.5	371	27.6	297	23	247
12.7	28	1287	758	47.7	513	35.8	385	28.6	308	23.8	256
13.2	29	1333	785	49.4	531	37	398	29.6	319	24.7	266
13.6	30	1379	812	51.1	550	38.3	412	30.6	330	25.5	275

Table 6

For installations in locations above 800 meters the room size and mitigation airflow must be adjusted with a factor from this chart

ALTITUDE CORRECTION FACTOR													
Altitude(m)	800	1000	1200	1400	1600	1800	2000	2200	2400	2600	2800	3000	3200
Altitude (ft)	2625	3281	39.7	4693	5349	5349	5906	6562	7874	8530	9186	9843	10499
Adj. Factor (AF)	1.02	1.05	1.07	1.1	1.12	1.12	1.15	1.18	1.25	1.28	1.32	1.36	1.4

TABLE 7

A2L SENSOR REPLACEMENT

- 1) Remove front bottom panel to access coil
- 2) Disconnect A2L harness from existing installed sensor.
- 3) Remove installed A2L sensor from bracket by removing two screws as shown in Figure 8. (use existing screws to install new sensor)
- 4) Attach new sensor to bracket using two existing screws. See Figure 8
TAKE CAUTION – DO NOT SCREW INTO COIL/TUBING
- 5) Connect A2L harness to new installed sensor.

Note: Check that cabling will not be subject to wear, corrosion, excessive pressure, vibration, sharp edges or any other adverse environmental effects. The check shall also take into account the effects of aging or continual vibration from sources such as compressors or fans.

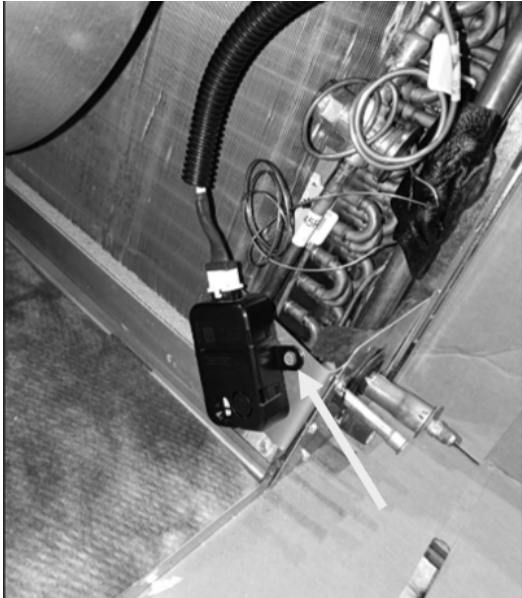

Figure 8 - Replacing Sensor to Bracket

DIMENSIONS

DIMENSIONS										
MODEL	H	W	D	A	B	C	E	F	G	SHP WT
12CLX	27-3/8" (69.53)	22-3/8" (56.83)	24-3/8" (61.91)	15-7/8" (40.32)	19-1/4" (48.89)	16" (40.64)	12" (30.48)	2-3/8" (6.03)	7-3/4" (19.68)	110 (49.89)
24CLX	27-3/8" (69.53)	22-3/8" (56.83)	24-3/8" (61.91)	15-7/8" (40.32)	19-1/4" (48.89)	16" (40.64)	16" (40.64)	2-3/8" (6.03)	7-3/4" (19.68)	120 (54.43)
25/36 CLX	29-3/8" (74.61)	26-3/8" (66.99)	26-3/8" (66.99)	18-3/8" (46.67)	22-3/8" (56.83)	18" (45.72)	16" (40.64)	3" (7.62)	7-3/4" (19.68)	130 (58.97)
37CLX	35-3/8" (89.85)	26-3/8" (66.99)	26-3/8" (66.99)	24-3/8" (61.91)	22-3/8" (56.83)	18" (45.72)	16" (40.64)	3" (7.62)	7-3/4" (19.68)	140 (63.5)

TABLE 8

DIMENSIONS										
MODEL	H	W	D	A	B	C	E	F	G	
12CLX(W/Q)	27-3/8" (69.5)	22-3/8" (56.8)	24-3/8" (61.9)	15-7/8" (40.3)	20-1/2" (52)	16" (40.6)	12" (30.5)	2-3/8" (6)	7-3/4" (19.7)	
24CLX(W/Q)	27-3/8" (69.5)	22-3/8" (56.8)	24-3/8" (61.9)	15-7/8" (40.3)	20-1/2" (52)	16" (40.6)	12" (30.5)	2-3/8" (6)	7-3/4" (19.7)	
25/36 CLX(W/Q)	29-3/8" (74.6)	26-3/8" (67)	26-3/8" (67)	18-3/8" (46.7)	23-1/4" (59)	18" (45.7)	16" (40.6)	3" (7.6)	7-1/4" (18.4)	
37CLX(W/Q)	35-3/8" (89.6)	26-3/8" (67)	26-3/8" (67)	18-3/8" (46.7)	23-1/4" (59)	18" (45.7)	16" (40.6)	3" (7.6)	7-1/4" (18.4)	

TABLE 9

DIMENSIONS										
MODEL	H	W	D	A	B	C	E	F	G	SHP WT
24CLP	27-3/8" (69.53)	22-3/8" (56.83)	24-3/8" (61.91)	15-7/8" (40.32)	20-1/2	16" (40.64)	16" (40.64)	2-3/8" (6.03)	4	120 (54.43)
36CLP	29-3/8" (74.61)	26-3/8" (66.99)	26-3/8" (66.99)	18-3/8" (46.67)	22-3/8" (56.83)	18" (45.72)	16" (40.64)	3" (7.62)	5	130 (58.97)

TABLE 10

DIMENSIONS										
MODEL	H	W	D	A	B	C	E	F	G	SHP WT
24CLP(W/Q)	27-3/8" (69.53)	22-3/8" (56.83)	24-3/8" (61.91)	15-7/8" (40.32)	20-1/2	16" (40.64)	16" (40.64)	2-3/8" (6.03)	7-3/4" (19.68)	120 (54.43)
36CLP(W/Q)	29-3/8" (74.61)	26-3/8" (66.99)	26-3/8" (66.99)	18-3/8" (46.67)	22-3/8" (56.83)	18" (45.72)	16" (40.64)	3" (7.62)	7-1/4" (18.41)	130 (58.97)

TABLE 11

DIMENSIONS CONTINUED

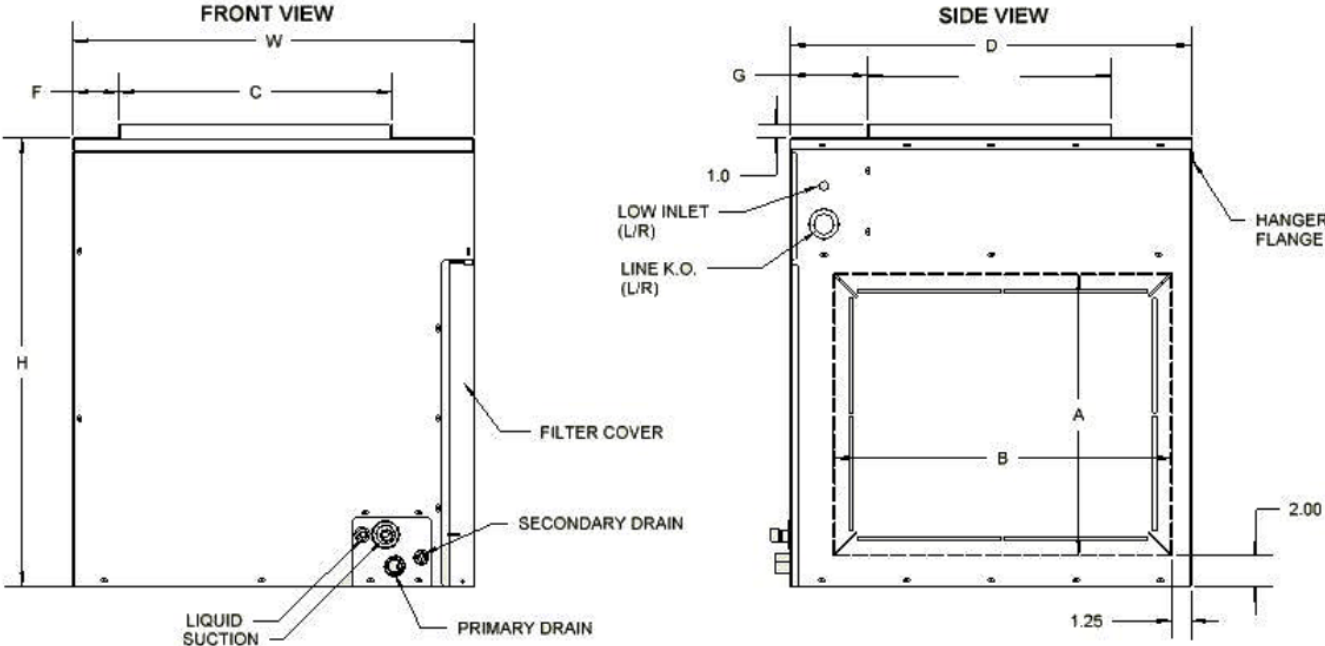

Figure 9 Unit Dimensions

NOTES



P.O. Box 270969 Dallas, TX 75227
www.firstco.com or www.ae-air.com

The manufacturer works to continually improve its products. It reserves the right to change design and specifications without notice.

©2022 First Co., Applied Environmental Air