

Control de Documento**A. Revisiones y aprobaciones del documento.**

Actividad	Puesto	Nombre	Fecha
Elaboró:	Diseñador	Adriana Vega	23/11/18
Revisó:	Dir. Calidad y Producto	Alejandro Montelongo	23/11/18
Aprobó:	Dir. Calidad y Producto	Alejandro Montelongo	23/11/18

B. Descripción de cambios

Fecha	Rev.	Solicitante	Naturaleza del cambio
23/11/18	A	A.VEGA	ELABORACIÓN DE DESPIECES
29/03/19	B	LUIS AGUILAR	SE INCLUYE VALVULA DE EQUILIBRIO

NO IMPRIMIR 1^{er} HOJA "CONTROL DOCUMENTAL"

IMPRIMIR APARTIR DE LA 2^{DA} HOJA

FAGOR



DESPIECE

PARTS BREAKDOWNS

CONDENSING UNITS / UNIDADES DE CONDENSACIÓN

ZONA/ZONE		CONDENSING UNITS / UNIDADES DE CONDENSACIÓN		LAMINA/DRAWING							QVR/QVF						
ITEM	REFERENCIA REFERENCE	DENOMINACIÓN	DENOMINATION	CONDENSING UNITS / UNIDADES DE CONDENSACIÓN							RECOMENDED	ELIMINADO ELIMINATED	INTRODUCIDO INTRODUCED	NOTAS / NOTES			
				QVR-1 N	QVR-1G N	QVR-2 N	QVR-2G N	QVR-3 N	QVR-3G N	QVF-1 N					QVF-2 N	QVF-3 N	
	12199605	CONDENSING UNIT	UNIDAD CONDENSACION	1	1												
2	12206064	DECK	BANCADA	1	1												
3	12190505	COMPRESSOR 115V	COMPRESOR 115V	1	1							X					
4	-	START KIT	KIT ARRANQUE	1	1												
5	12032903	CONDENSER	CONDENSADOR	1	1												
6	12188004	FILTER	FILTRO	1	1												
7	12190422	HEAT EXCHANGER	INTERCAMBIADOR DE CALOR	1	1												
8	12189560	CONDENSING TRAY	BANDEJA CONDENSACIÓN	1	1												
9	12190510	ELECTRICAL MOTOR 115/60	MOTOR ELECTRICO 115/60	1	1							X					
10	12188078	FAN PLASTIC BLADE	ASPA PLÁSTICA 9"	1	1												
11	12191294	BRACKET SUPPORT	SOPORTE VENTILADOR	1	1												
12	12190610	POWER CORD (SPIDER HUB)	ARAÑA CONEXIONES	1	1							X					
13	12037369	SCHRADER VALVE	VALVULA	1	1												
14	12190608	POWER CORD	CORDON TOMACORRIENTE	1	1												
15	-	CAP TUBE	TUBO CAPILAR	1	1							X					
	12199606	CONDENSING UNIT	UNIDAD CONDENSACION			1	1										
2	12193080	DECK	BANCADA			1	1										
3	12190495	COMPRESSOR 115V	COMPRESOR 115V			1	1					X					
4	-	START KIT	KIT ARRANQUE			1	1										
5	12032116	CONDENSER	CONDENSADOR			1	1										
6	12188004	FILTER	FILTRO			1	1										
7	12190421	HEAT EXCHANGER	INTERCAMBIADOR DE CALOR			1	1										
8	12189560	CONDENSING TRAY	BANDEJA CONDENSACIÓN			1	1										
9	12190510	ELECTRICAL MOTOR 115/60	MOTOR ELECTRICO 115/60			1	1					X					
10	12188078	FAN PLASTIC BLADE	ASPA PLÁSTICA 9"			1	1										
11	12191294	BRACKET SUPPORT	SOPORTE PORTERIA			1	1										
12	12190610	POWER CORD (SPIDER HUB)	ARAÑA CONEXIONES			1	1					X					
13	12037369	SCHRADER VALVE	VALVULA			1	1										
14	12190608	POWER CORD	CORDON TOMACORRIENTE			1	1										
15	-	CAP TUBE	TUBO CAPILAR			1	1					X					
	12199590	CONDENSING UNIT	UNIDAD CONDENSACION					1	1								
2	12192914	DECK	BANCADA					1	1								
3	12190490	COMPRESSOR 115V	COMPRESOR 115V					1	1			X					
4	-	START KIT	KIT ARRANQUE					1	1								
5	12190810	CONDENSER	CONDENSADOR					1	1								
6	12188004	FILTER	FILTRO					1	1								
7	12190421	HEAT EXCHANGER	INTERCAMBIADOR DE CALOR					2	2								
8	12189560	CONDENSING TRAY	BANDEJA CONDENSACIÓN					1	1								
9	12190510	ELECTRICAL MOTOR 115/60	MOTOR ELECTRICO 115/60					1	1			X					
10	12188078	FAN PLASTIC BLADE	ASPA PLÁSTICA 9"					1	1								
11	12191294	BRACKET SUPPORT	SOPORTE PORTERIA					1	1								
12	12190610	POWER CORD (SPIDER HUB)	ARAÑA CONEXIONES					1	1			X					
13	12037369	SCHRADER VALVE	VALVULA					1	1								
14	12190608	POWER CORD	CORDON TOMACORRIENTE					1	1								
15	-	CAP TUBE	TUBO CAPILAR					1	1			X					

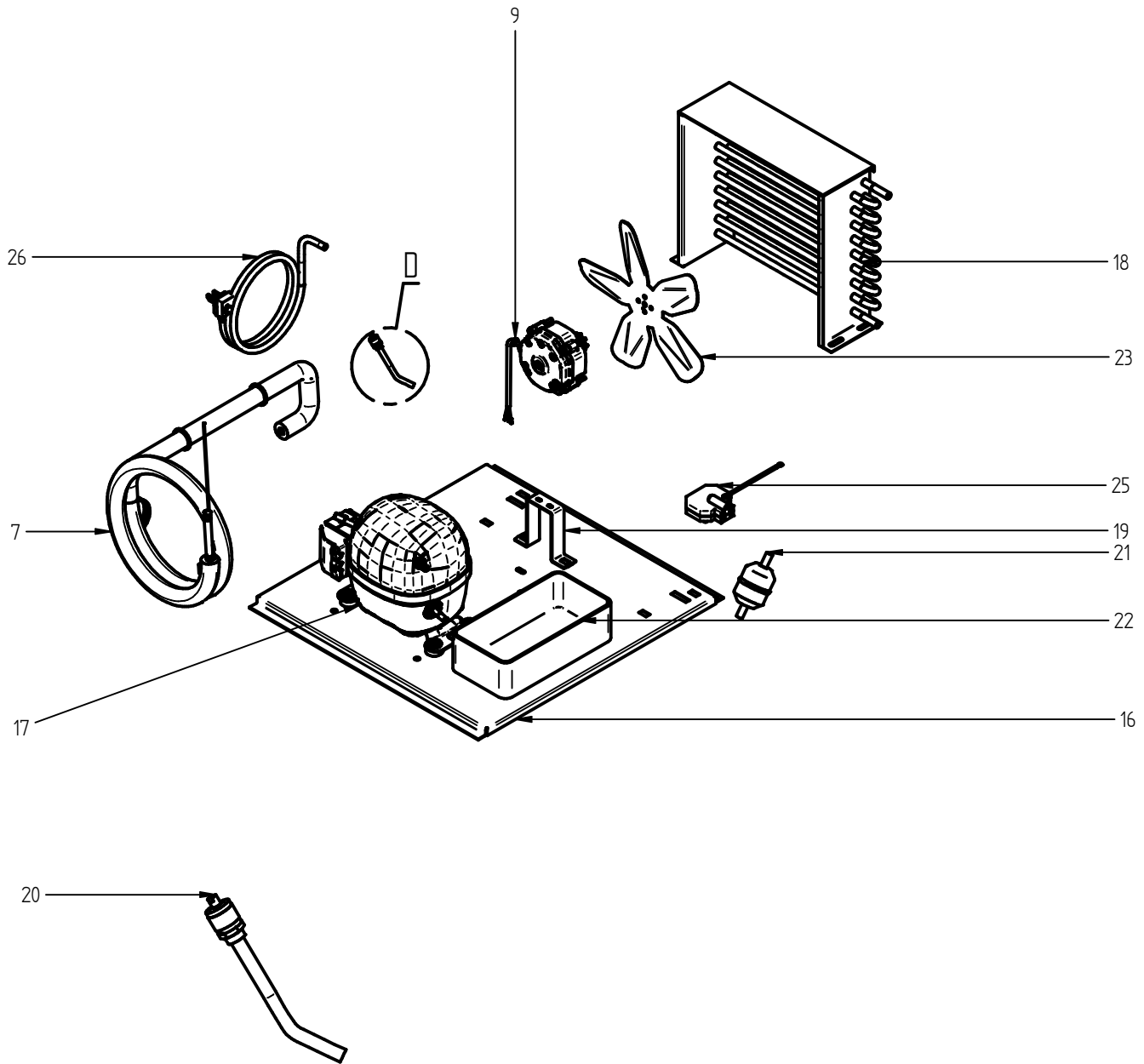

DETAIL D

FAGOR



DESPIECE

PARTS BREAKDOWNS

CONDENSING UNITS / UNIDADES DE CONDENSACIÓN

ZONA/ZONE				CONDENSING UNITS / UNIDADES DE CONDENSACIÓN						LAMINA/DRAWING			QVR/QVF				
ITEM	REFERENCIA REFERENCE	DENOMINACIÓN	DENOMINATION	R						F			RECOMENDED	ELIMINADO ELIMINATED	INTRODUCIDO INTRODUCED	NOTAS / NOTES	
				QVR-1 N	QVR-1G N	QVR-2 N	QVR-2G N	QVR-3 N	QVR-3G N	QVF-1 N	QVF-2 N	QVF-3 N					
CONDENSING UNITS / UNIDADES DE CONDENSACIÓN																	
	12199607	CONDENSING UNIT	UNIDAD CONDENSACION								1						
16	12206039	DECK	BANCADA								1						
17	12190490	COMPRESSOR 115V	COMPRESOR 115V								1			X			
	-	START KIT	KIT ARRANQUE								1						
18	12190810	CONDENSER	CONDENSADOR								1						
19	12191294	BRACKET SUPPORT	SOPORTE PORTERÍA								1						
20	12037369	SCHRADER VALVE	VALVULA								1						
21	12188004	FILTER	FILTRO								1						
22	12189560	CONDENSING TRAY	BANDEJA CONDENSACIÓN								1						
23	12188078	FAN PLASTIC BLADE	ASPA PLÁSTICA 9"								1						
24	12190510	ELECTRICAL MOTOR 115/60	MOTOR ELECTRICO 115/60								1			X			
25	12190608	POWER CORD (SPIDER HUB)	ARAÑA CONEXIONES								1			X			
26	12190608	POWER CORD	CORDON TOMACORRIENTE								1						
27	12198271	COPPER PIPE	TUBO DE COBRE								1			X			
	12199608	CONDENSING UNIT	UNIDAD CONDENSACION								1						
16	12206039	DECK	BANCADA								1						
17	12190499	COMPRESSOR 115V	COMPRESOR 115V								1			X			
	-	START KIT	KIT ARRANQUE								1						
18	12190810	CONDENSER	CONDENSADOR								1						
19	12191294	BRACKET SUPPORT	SOPORTE PORTERÍA								1						
20	12037369	SCHRADER VALVE	VALVULA								1						
21	12188004	FILTER	FILTRO								1						
22	12189560	CONDENSING TRAY	BANDEJA CONDENSACIÓN								1						
23	12188078	FAN PLASTIC BLADE	ASPA PLÁSTICA 9"								1						
24	12190510	ELECTRICAL MOTOR 115/60	MOTOR ELECTRICO 115/60								1			X			
25	12190608	POWER CORD (SPIDER HUB)	ARAÑA CONEXIONES								1			X			
26	12190608	POWER CORD	CORDON TOMACORRIENTE								1						
27	12198277	COPPER PIPE	TUBO DE COBRE								1			X			
	12199572	CONDENSING UNIT	UNIDAD CONDENSACION								1						
16	12207700	DECK	BANCADA								1						
17	12190501	COMPRESSOR 115V	COMPRESOR 115V								1			X			
	-	START KIT	KIT ARRANQUE								1						
18	12190815	CONDENSER	CONDENSADOR								1						
19	12191294	BRACKET SUPPORT	SOPORTE PORTERÍA								2						
20	12037369	SCHRADER VALVE	VALVULA								1						
21	12188004	FILTER	FILTRO								1						
22	12189560	CONDENSING TRAY	BANDEJA CONDENSACIÓN								1						
23	12188078	FAN PLASTIC BLADE	ASPA PLÁSTICA 9"								2						
24	12190510	ELECTRICAL MOTOR 115/60	MOTOR ELECTRICO 115/60								2			X			
25	12190608	POWER CORD (SPIDER HUB)	ARAÑA CONEXIONES								1			X			
26	12190608	POWER CORD	CORDON TOMACORRIENTE								1						
27	12198283	COPPER PIPE	TUBO DE COBRE								1			X			

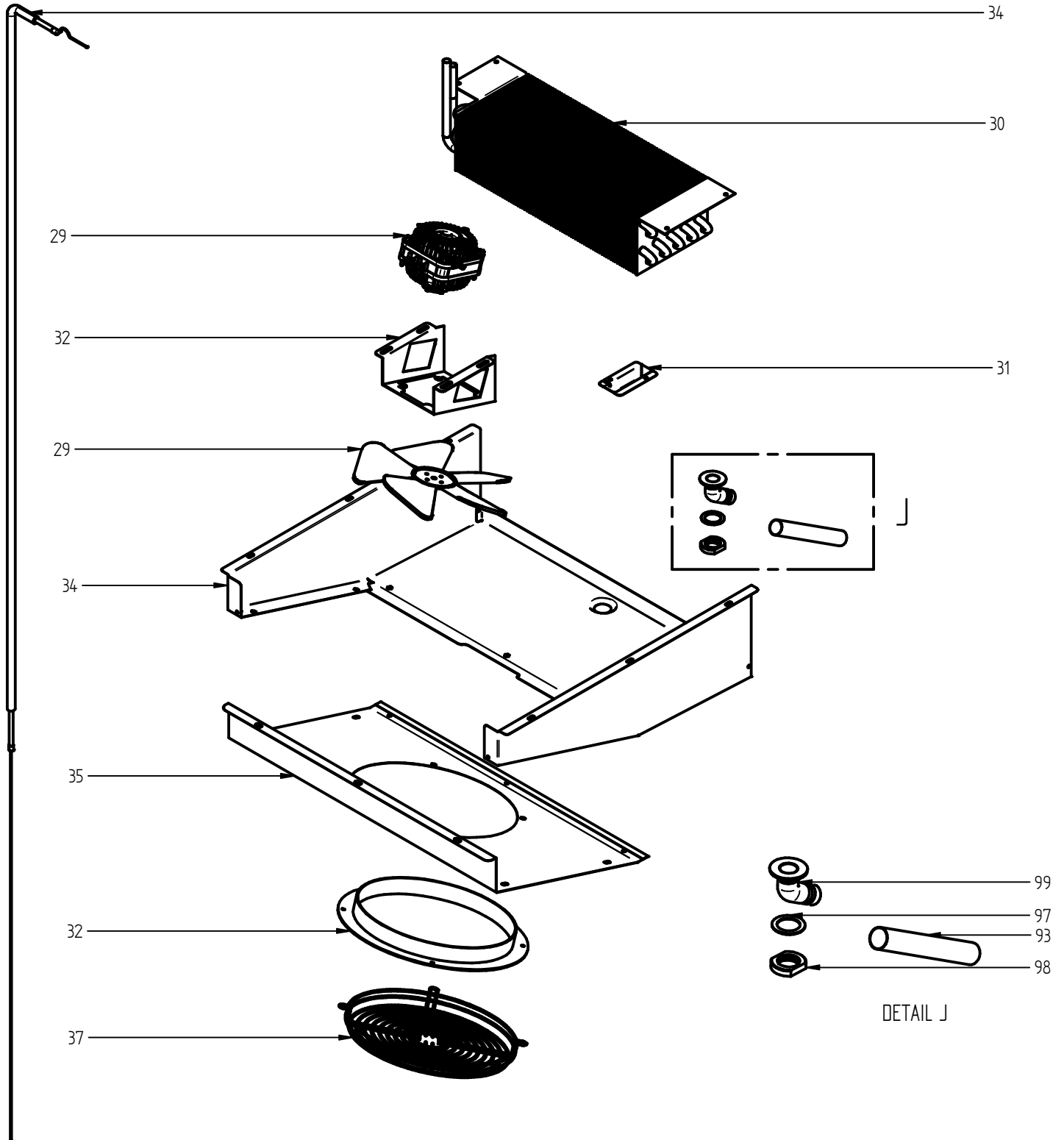



ZONA/ZONE EVAPORATION UNITS / UNIDADES DE EVAPORACIÓN LAMINA/DRAWING QVR/QVF

ITEM	REFERENCIA REFERENCE	DENOMINACIÓN	DENOMINATION	R						F			RECOMENDED	ELIMINADO ELIMINATED	INTRODUCIDO INTRODUCED	NOTAS / NOTES
				QVR-1 N	QVR-1G N	QVR-2 N	QVR-2G N	QVR-3 N	QVR-3G N	QVF-1 N	QVF-2 N	QVF-3 N				

EVAPORATION UNITS / UNIDADES DE EVAPORACIÓN																	
	12199483	EVAPORATION UNIT	UNIDAD EVAPORACION	1	1												
28	12210710	EVAPORATOR COVER	CUBIERTA EVAPORADOR	1	1												
29	12190510	ELECTRICAL MOTOR 115/60	MOTOR ELECTRICO 115/60	1	1								X				
29	12190018	PLASTIC BLADE 8-28	ASPA PLASTICA 8-28	1	1												
30	12189576	EVAPORATOR COIL	EVAPORADOR	1	1												
31	12192255	COVER PROBE	PROTECTOR SONDA	1	1												
32	12190068	FAN SUPORT	ARO SOPORTE VENTILADOR	1	1												
33	12210710	EVAPORATION COVER KIT	KIT CUBIERTA EVAPORADOR	1	1												
34	12190422	EXCHANGER R 1CPO	INTERCAMBIADOR REFRIGERACION 1CPO	1	1								X				
	12199484	EVAPORATION UNIT	UNIDAD EVAPORACION			1	1										
27	12199504	EVAPORATOR COVER	CUBIERTA EVAPORADOR			1	1										
28	12190510	ELECTRICAL MOTOR 115/60	MOTOR ELECTRICO 115/60			1	1						X				
29	12190018	PLASTIC BLADE 8-28	ASPA PLASTICA 8-28			1	1										
30	12190779	EVAPORATOR COIL	EVAPORADOR			1	1										
31	12192255	COVER PROBE	PROTECTOR SONDA			1	1										
32	12190068	FAN SUPORT	ARO SOPORTE VENTILADOR			1	1										
33	12199504	EVAPORATION COVER KIT	KIT CUBIERTA EVAPORADOR			1	1										
34	12190421	EXCHANGER R 2CPOS	INTERCAMBIADOR REFRIGERACION 2CPOS			1	1						X				
	12199468	EVAPORATION UNIT	UNIDAD EVAPORACION					2	2								
27	12199504	EVAPORATOR COVER	CUBIERTA EVAPORADOR					2	2								
28	12190510	ELECTRICAL MOTOR 115/60	MOTOR ELECTRICO 115/60					1	1				X				
29	12190018	PLASTIC BLADE 8-28	ASPA PLASTICA 8-28					2	2								
30	12190783	EVAPORATOR COIL	EVAPORADOR					2	2								
31	12192255	COVER PROBE	PROTECTOR SONDA					2	2								
32	12190068	FAN SUPORT	ARO SOPORTE VENTILADOR					2	2								
33	12199504	EVAPORATION COVER KIT	KIT CUBIERTA EVAPORADOR					2	2								
34	12190421	EXCHANGER R 2CPOS	INTERCAMBIADOR REFRIGERACION 2CPOS					2	2				X				
	12210710	EVAPORATION COVER KIT	KIT CUBIERTA EVAPORADOR	1	1												
35	12210714	EVAPORATION COVER	CUBIERTA EVAPORADOR	1	1												
36	12210713	EVAPORATION COVER TOP	TAPA CUBIERTA EVAPORADOR	1	1												
37	12210712	EVAPORATION COVER	CUBIERTA EVAPORADOR	1	1												
38	12210711	EVAPORATION COVER TOP	TAPA CUBIERTA EVAPORADOR	1	1												
	12199504	EVAPORATION COVER KIT	KIT CUBIERTA EVAPORADOR			1	1	2	2								
35	12209275	EVAPORATION COVER	CUBIERTA EVAPORADOR			1	1	2	2								
36	12209276	EVAPORATION COVER TOP	TAPA CUBIERTA EVAPORADOR			1	1	2	2								
37	12190068	FAN SUPORT	SOPORTE VENTILADOR			1	1	2	2								
38	12190728	FAN GRID	REJILLA VENTILADOR			1	1	2	2								
39	12190073	DRAIN	DESAGÜE	1	1	1	1	2	2								
40	12189956	PLASTIC SELL	JUNTA GOMA DESAGUE	1	1	1	1	2	2								
41	12189976	DRAIN NUT	TUERCA 7/8-14 NYLON	1	1	1	1	2	2								

DRAIN/ DRENAJE

93	12190472	FLEX DRAIN HOSE 5/8"	MAGUERA DESAGUE FLEXIBLE	0.1	0.1	0.1	0.1	0.2	0.2	0.1	0.1	0.2					
94	12191846	CORRUGATED HOSE	MANGUERA CORRUGADA	1	1	1	1			1	1	1					
95	12190467	CURVED HOSE	MAGUERA CURVA					1	1								
97	12189956	RUBBER JOINT1/2"	JUNTA GOMA DESAGUE	1	1	1	1	2	2	1	1	1					
98	12189976	NUT NYLON 7/8-14	TUERCA NYLON 7/8-14	1	1	1	1	2	2	1	1	1					
99	12190073	DRAIN ELBOW 5/8"60°	CODO DESAGUE 5/8"60°	1	1	1	1	2	2	1	1	1					

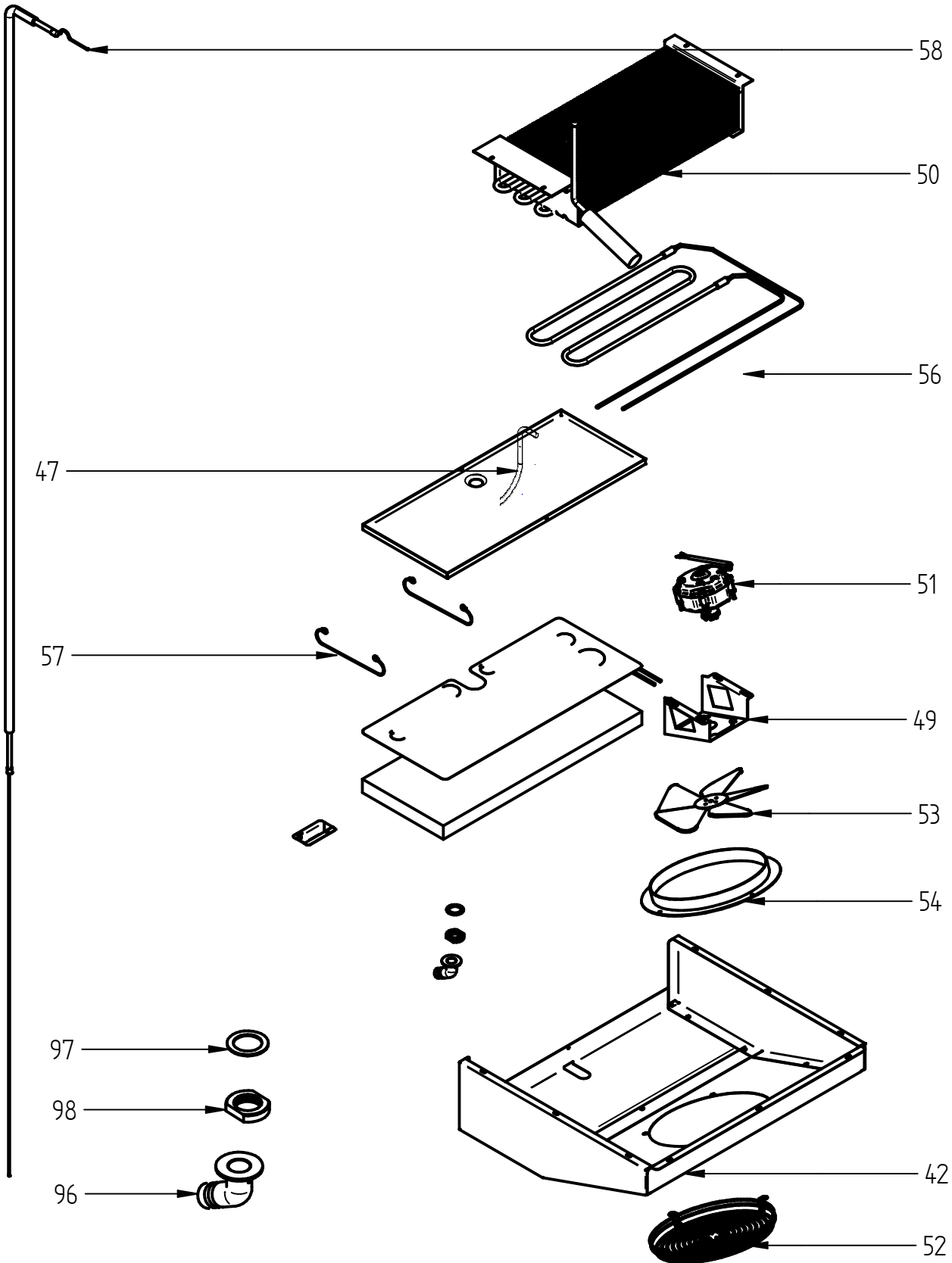

DETAIL D

FAGOR



DESPIECE

PARTS BREAKDOWNS

EVAPORATION UNITS / UNIDADES DE EVAPORACIÓN

ZONA/ZONE EVAPORATION UNITS / UNIDADES DE EVAPORACIÓN

LAMINA/DRAWING

QVR/QVF

ITEM	REFERENCIA REFERENCE	DENOMINACIÓN	DENOMINATION	R						F			RECOMENDADO	ELIMINADO ELIMINATED	INTRODUCIDO INTRODUCED	NOTAS / NOTES
				QVR-1 N	QVR-1 G N	QVR-2 N	QVR-2 G N	QVR-3 N	QVR-3 G N	QVF-1 N	QVF-2 N	QVF-3 N				
EVAPORATION UNITS / UNIDADES DE EVAPORACIÓN																
	12199485	EVAPORATION UNIT FREEZER	UNIDAD DE EVAPORACIÓN CONGELADOR									1				
42	12199501	EVAPORATION TRAY	BANDEJA DE EVAPORACIÓN									1				
43	12205869	LATERAL RIGHT EVAPORATION TRAY	LATERAL DERECHA BANDEJA EVAPORADOR									1				
44	12205870	LATERAL LEFT EVAPORATION TRAY	LATERAL IZQUIERDA BANDEJA EVAPORADOR									1				
45	12205871	COVER EVAPORATION TRAY	TAPA BANDEJA DE EVAPORADOR									1				
46	12205872	BOTTOM COVER EVAPORATION TRAY	TAPA INFERIOR DE EVAPORADOR									1				
47	12207423	DRAIN PAN	BANDEJA DE ESCURRIMIENTO									1				
48	12205873	TRAY SUPPORT	SOPORTE DE BANDEJA EVAPORADOR									1				
49	12205858	MOTOR BASE	BASE PARA MOTOR									1				
50	12190781	EVAPORATOR QF-14X7	EVAPORADOR QF-14X7									1				
51	12188296	ELECTRICAL MOTOR 115/60	MOTOR ELECTRICO 115/60									1	X			
52	12190728	GRID FAN	REJILLA PARA VENTILADOR									1				
53	12190018	PLASTIC BLADE 8-28	ASPA PLASTICA 8-28									1				
54	12190068	RING CONDUCTIVE	ARO CONDUCTOR									1				
55	12190574	RESISTANCE DRAIN	RESISTENCIA DESAGÜE									1				
56	12190553	FOIL HEATER ALUMINIUM	RESISTENCIA ADHERIBLE ALUMINIO									1				
57	12190727	CLIP EVAPORATOR	CLIP EVAPORADOR									2				
58	12190423	EXCHANGER FREEZER 1CPO	INTERCAMBIADOR CONGELADOR 1CPO									1	X			
	12199486	EVAPORATION UNIT FREEZER	UNIDAD DE EVAPORACIÓN CONGELADOR									1				
42	12199502	EVAPORATION TRAY	BANDEJA DE EVAPORACIÓN									1				
43	12205869	LATERAL RIGHT EVAPORATION TRAY	LATERAL DERECHA BANDEJA EVAPORADOR									1				
44	12205870	LATERAL LEFT EVAPORATION TRAY	LATERAL IZQUIERDA BANDEJA EVAPORADOR									1				
45	12205874	COVER EVAPORATION TRAY	TAPA BANDEJA DE EVAPORADOR									1				
46	12205875	BOTTOM COVER EVAPORATION TRAY	TAPA INFERIOR DE EVAPORADOR									1				
47	12207424	DRAIN PAN	BANDEJA DE ESCURRIMIENTO									1				
48	12205873	TRAY SUPPORT	SOPORTE DE BANDEJA EVAPORADOR									2				
49	12205858	MOTOR BASE	BASE PARA MOTOR									2				
50	12190785	EVAPORATOR QF-14X7	EVAPORADOR QF-14X7									1				
51	12188296	ELECTRICAL MOTOR 115/60	MOTOR ELECTRICO 115/60									2	X			
52	12190728	GRID FAN	REJILLA PARA VENTILADOR									2				
53	12190018	PLASTIC BLADE 8-28	ASPA PLASTICA 8-28									2				
54	12190068	RING CONDUCTIVE	ARO CONDUCTOR									2				
55	12190574	RESISTANCE DRAIN	RESISTENCIA DESAGÜE									1				
56	12190554	FOIL HEATER ALUMINIUM	RESISTENCIA ADHERIBLE ALUMINIO									1				
57	12190727	CLIP EVAPORATOR	CLIP EVAPORADOR									2				
58	12190424	EXCHANGER FREEZER 2CPOS	INTERCAMBIADOR CONGELADOR 2CPOS									1	X			
	12199447	EVAPORATION UNIT FREEZER	UNIDAD DE EVAPORACIÓN CONGELADOR									1				
42	12199503	EVAPORATION TRAY	BANDEJA DE EVAPORACIÓN									1				
43	12207425	LATERAL RIGHT EVAPORATION TRAY	LATERAL DERECHA BANDEJA EVAPORADOR									1				
44	12207426	LATERAL LEFT EVAPORATION TRAY	LATERAL IZQUIERDA BANDEJA EVAPORADOR									1				
45	12207427	COVER EVAPORATION TRAY	TAPA BANDEJA DE EVAPORADOR									1				
46	12207428	BOTTOM COVER EVAPORATION TRAY	TAPA INFERIOR DE EVAPORADOR									1				
47	12207429	DRAIN PAN	BANDEJA DE ESCURRIMIENTO									1				
48	12205873	TRAY SUPPORT	SOPORTE DE BANDEJA EVAPORADOR									2				
49	12205796	MOTOR BASE	BASE PARA MOTOR									2				
50	12190789	EVAPORATOR QF-14X7	EVAPORADOR QF-14X7									1				
51	12188296	ELECTRICAL MOTOR 115/60	MOTOR ELECTRICO 115/60									2	X			
52	12190728	GRID FAN	REJILLA PARA VENTILADOR									2				
53	12190018	PLASTIC BLADE 8-28	ASPA PLASTICA 8-28									2				
54	12190068	RING CONDUCTIVE	ARO CONDUCTOR									2				
55	12190574	RESISTANCE DRAIN 115V	RESISTENCIA DESAGÜE									1				
56	12190555	FOIL HEATER ALUMINIUM115V	RESISTENCIA ADHERIBLE ALUMINIO									1				
57	12190727	CLIP EVAPORATOR	CLIP EVAPORADOR									2				
58	12190432	EXCHANGER FREEZER 3CPOS	INTERCAMBIADOR CONGELADOR 3CPOS									1	X			
DRAIN/ DRENAJE																
96	12190072	ELBOW 90°	CODO 90°						2	2						
97	12189956	RUBBER JOINT1/2"	JUNTA GOMA DESAGUE	1	1	1	1	1	2	2	1	1	1			
98	12189976	NUT NYLON 7/8-14	TUERCA NYLON 7/8-14	1	1	1	1	1	2	2	1	1	1			

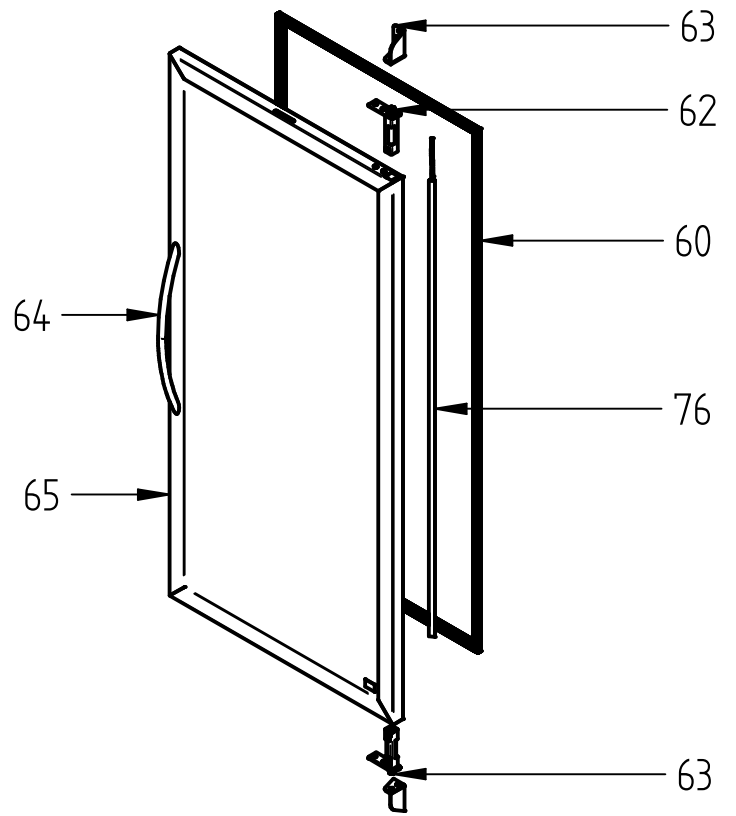
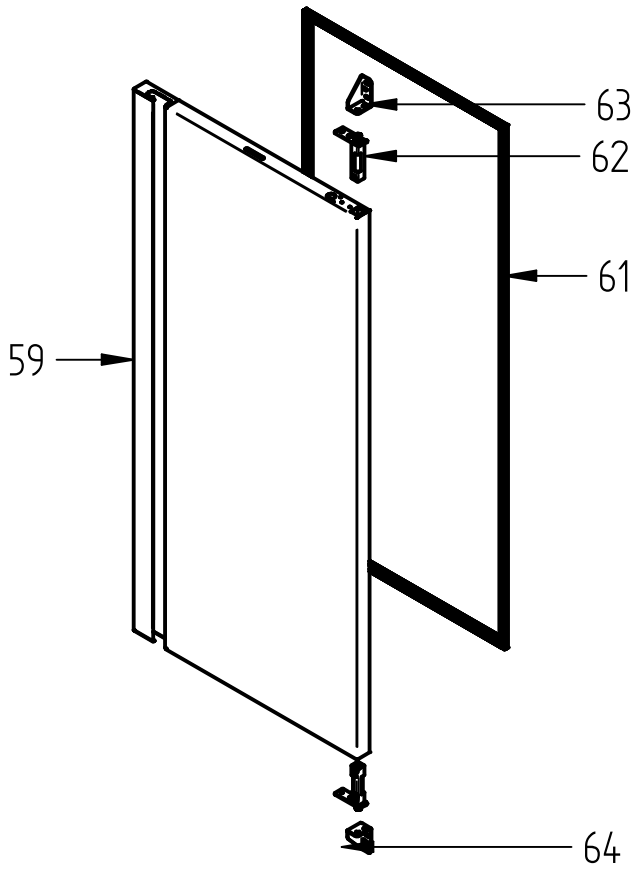



ZONA/ZONE		SEVERAL DEVICES		LAMINA/DRAWING										QVR/QVF		
ITEM	REFERENCIA REFERENCE	DENOMINACIÓN	DENOMINATION	R					F			RECOMENDED	ELIMINADO ELIMINATED	INTRODUCIDO INTRODUCED	NOTAS / NOTES	
				QVR-1 N	QVR-1G N	QVR-2 N	QVR-2G N	QVR-3 N	QVR-3G N	QVF-1 N	QVF-2 N					QVF-3 N
DOORS & OTHERS / PUERTAS & OTROS																
	12199291	DOOR KIT	ENSAMBLE DE PUERTAS	1												
59	12199293	DOOR KIT	ENSAMBLE DE PUERTAS			1										
60	12199292	DOOR ASSEMBLY	ENSAMBLE DE PUERTAS			2										
61	12191272	GASKET	BURLETE	1		2							X			
62	12038130	CARTRIDGE	BISAGRA DOBLE MUELLE	2		2							X			
63	12205991	TOP/RIGHT HINGE BOTTON/LEFT	BISAGRA SUP/DER INF/IZQ N	1		2							X			
64	12205992	TOP/LEFT HINGE BOTTON/RIGHT	BISAGRA SUP/IZQ INF/DER N	1		2							X			
	12199346	DOOR KIT	ENSAMBLE DE PUERTAS CRISTAL		1		2									
60	12191272	GASKET	BURLETE		1		2									
61	12038130	CARTRIDGE	BISAGRA DOBLE MUELLE		2		4						X			
62	12205991	TOP/RIGHT HINGE BOTTON/LEFT	BISAGRA SUP/DER INF/IZQ N		1		2						X			
63	12205992	TOP/LEFT HINGE BOTTON/RIGHT	BISAGRA SUP/IZQ INF/DER N		1		2						X			
64	12189960	HANDLE	JALADERA		1		2						X			
65	12199345	CRYSTAL DOOR ASSEMBLY	ENSAMBLE DE PUERTAS CRISTAL		1		2									
	12199294	DOOR KIT	ENSAMBLE DE PUERTAS							1						
59	12199295	DOOR ASSEMBLY	ENSAMBLE DE PUERTAS							3						
60	12191273	GASKET	BURLETE							3			X			
61	12038130	CARTRIDGE	BISAGRA DOBLE MUELLE							6			X			
62	12205991	TOP/RIGHT HINGE BOTTON/LEFT	BISAGRA SUP/DER INF/IZQ N							2			X			
63	12205992	TOP/LEFT HINGE BOTTON/RIGHT	BISAGRA SUP/IZQ INF/DER N							2			X			
	12199347	DOOR KIT	ENSAMBLE DE PUERTAS							1						
60	12191272	GASKET	BURLETE							3						
61	12038130	CARTRIDGE	BISAGRA DOBLE MUELLE							6			X			
62	12205991	TOP/RIGHT HINGE BOTTON/LEFT	BISAGRA SUP/DER INF/IZQ N							2			X			
63	12205992	TOP/LEFT HINGE BOTTON/RIGHT	BISAGRA SUP/IZQ INF/DER N							2			X			
64	12189960	HANDLE	JALADERA							3			X			
65	12199348	CRYSTAL DOOR ASSEMBLY	ENSAMBLE DE PUERTAS CRISTAL							3						
	12200245	DOOR KIT	ENSAMBLE DE PUERTAS							1						
59	12200246	DOOR ASSEMBLY	ENSAMBLE DE PUERTAS							1						
60	12191272	GASKET	BURLETE							1			X			
61	12038130	CARTRIDGE	BISAGRA DOBLE MUELLE							2			X			
62	12205991	TOP/RIGHT HINGE BOTTON/LEFT	BISAGRA SUP/DER INF/IZQ N							1			X			
63	12205992	TOP/LEFT HINGE BOTTON/RIGHT	BISAGRA SUP/IZQ INF/DER N							1			X			
	12200247	DOOR KIT	ENSAMBLE DE PUERTAS							1						
59	12200246	DOOR ASSEMBLY	ENSAMBLE DE PUERTAS							2						
60	12191272	GASKET	BURLETE							2			X			
61	12038130	CARTRIDGE	BISAGRA DOBLE MUELLE							4			X			
62	12205991	TOP/RIGHT HINGE BOTTON/LEFT	BISAGRA SUP/DER INF/IZQ N							2			X			
63	12205992	TOP/LEFT HINGE BOTTON/RIGHT	BISAGRA SUP/IZQ INF/DER N							2			X			
	12199294	DOOR KIT	ENSAMBLE DE PUERTAS							1						
59	12199295	DOOR ASSEMBLY	ENSAMBLE DE PUERTAS							3						
60	12191273	GASKET	BURLETE							3			X			
61	12038130	CARTRIDGE	BISAGRA DOBLE MUELLE							6			X			
62	12205991	TOP/RIGHT HINGE BOTTON/LEFT	BISAGRA SUP/DER INF/IZQ N							2			X			
63	12205992	TOP/LEFT HINGE BOTTON/RIGHT	BISAGRA SUP/IZQ INF/DER N							2			X			
CONTROLLERS & OTHERS / CONTROLES Y OTROS																
76	12190586	LED LIGHT	ILUMINACION LED		1		2		3				X			



ZONA/ZONE		SEVERAL DEVICES		LAMINA/DRAWING									QVR/QVF			
ITEM	REFERENCIA REFERENCE	DENOMINACIÓN	DENOMINATION	R						F			RECOMENDED	ELIMINADO ELIMINATED	INTRODUCIDO INTRODUCED	NOTAS / NOTES
				QVR-1 N	QVR-1GN	QVR-2 N	QVR-2GN	QVR-3 N	QVR-3GN	QVF-1 N	QVF-2 N	QVF-3 N				
WHEELS & LEGS / RUEDAS Y TACONES																
1	12200269	CAST KIT	KIT DE RUEDAS	1	1	1	1			1	1		X			
	12203699	CAST KIT	KIT DE RUEDAS					1	1			1	X			
	12191290	CASTER TOOL	LLAVE PARA RUEDAS	1	1	1	1			1	1	1				
	12190918	CASTER 4" W/BRAKE	RUEDA DELANTERA C/F Ø4"	2	2	2	2			2	2	3				
	12190917	CASTER 4" WO/ BRAKE	RUEDA DELANTERA S/F Ø4"	2	2	2	2			2	2	3				
	12191289	SHIMS	PLATINA NIVELADORA	8	8	8	8			8	8	12				
DRAIN/ DRENAJE																
93	12190472	FLEX DRAIN HOSE 5/8"	MAGUERA DESAGUE FLEXIBLE	0.1	0.1	0.1	0.1	0.2	0.2	0.1	0.1	0.2				
94	12191846	CORRUGATED HOSE	MANGUERA CORRUGADA	1	1	1	1			1	1	1				
95	12190467	CURVED HOSE	MAGUERA CURVA					1	1							
96	12190072	ELBOW 90°	CODO 90°					2	2							
97	12189956	RUBBER JOINT 1/2"	JUNTA GOMA DESAGUE	1	1	1	1	2	2	1	1	1				
98	12189976	NUT NYLON 7/8-14	TUERCA NYLON 7/8-14	1	1	1	1	2	2	1	1	1				
99	12190073	DRAIN ELBOW 5/8"60°	CODO DESAGUE 5/8"60°	1	1	1	1	2	2	1	1	1				

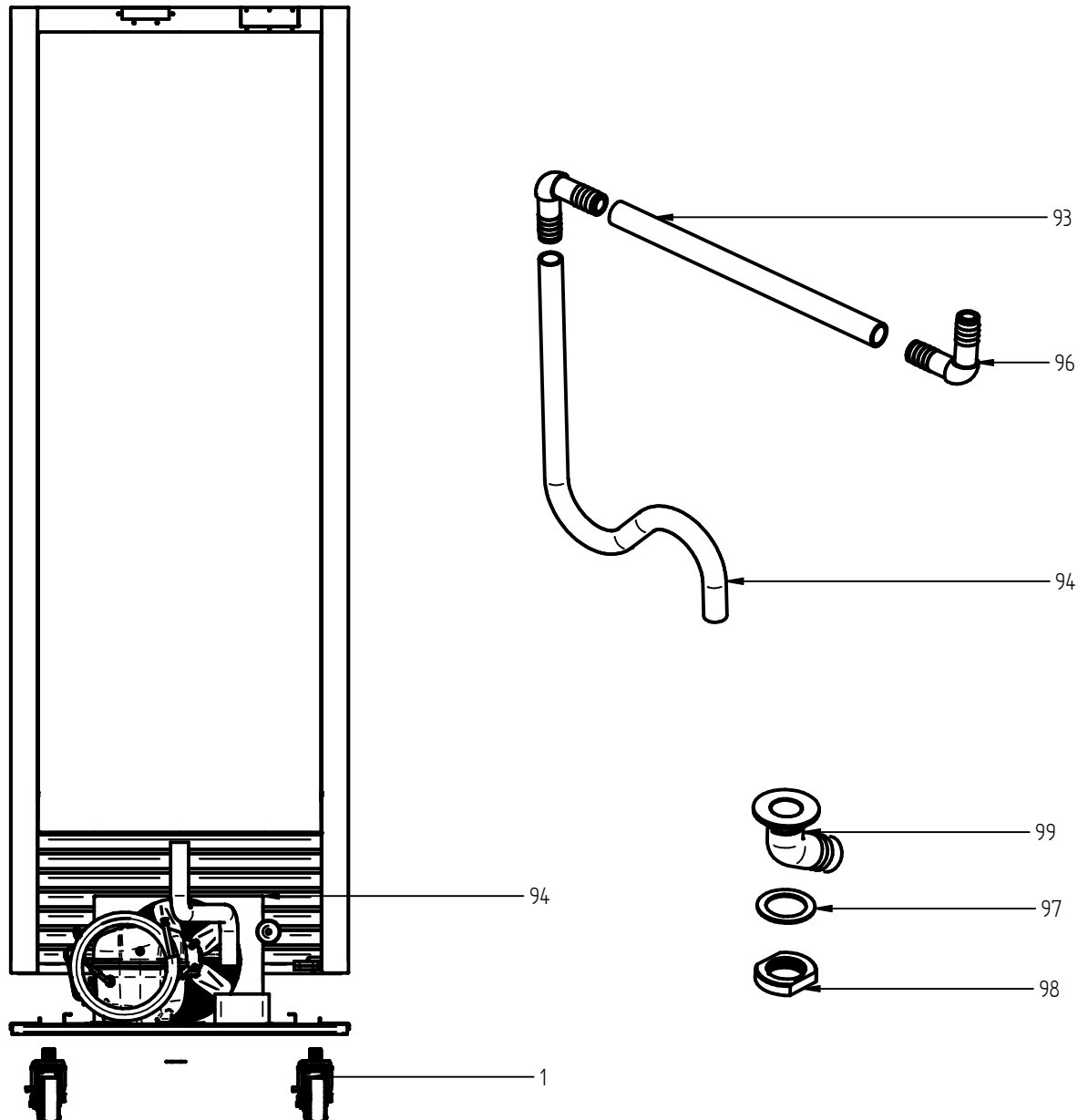

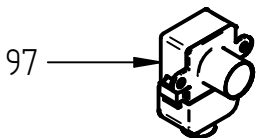
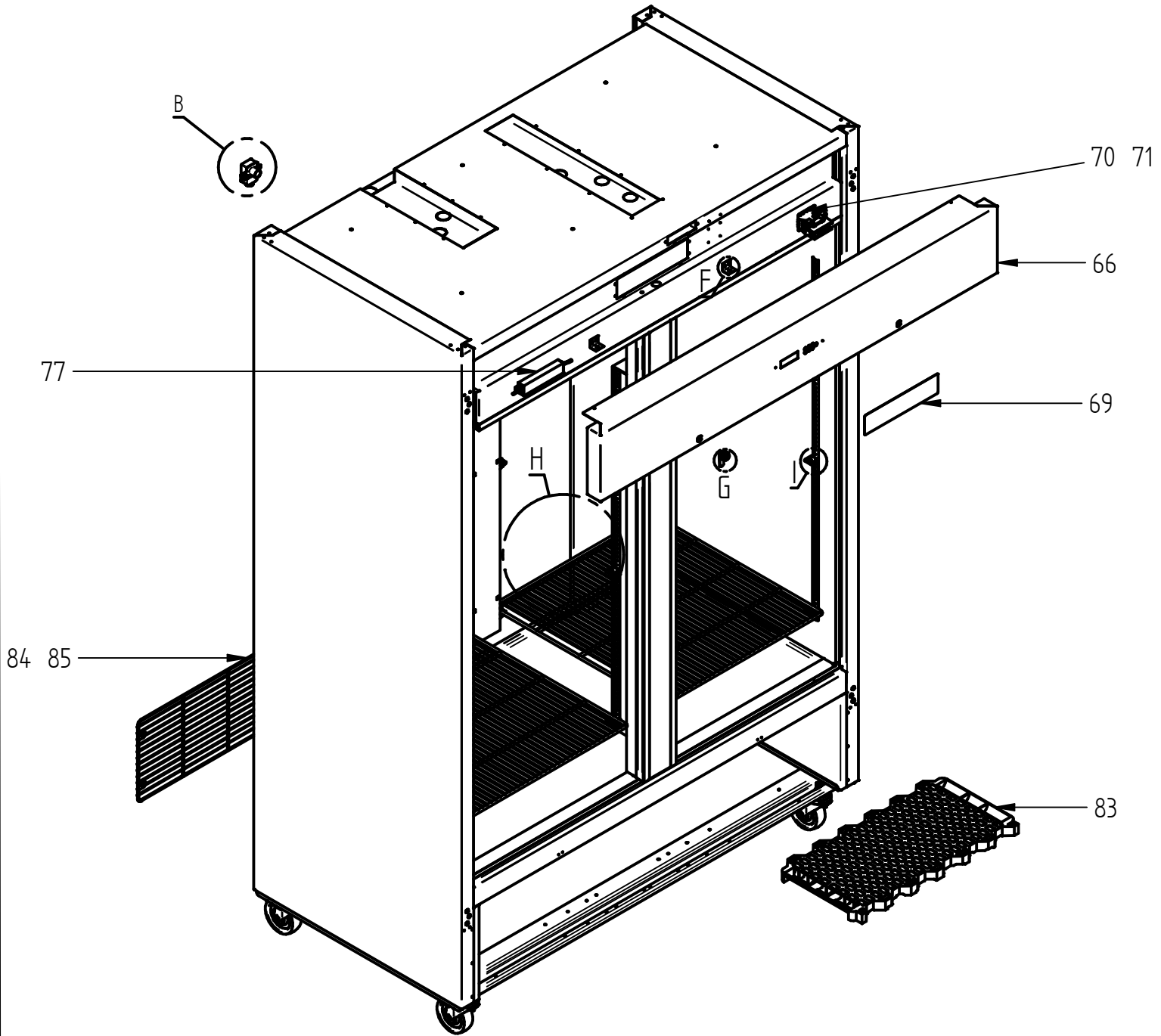

DETAIL B

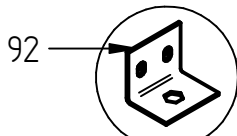

DETAIL F

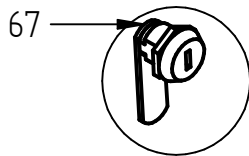

DETAIL G

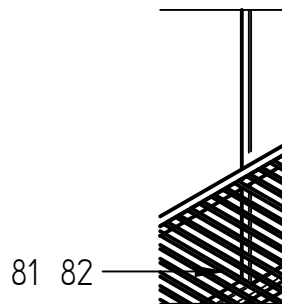

DETAIL H

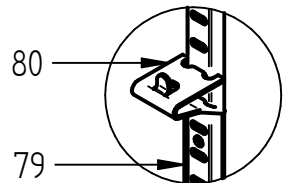

DETAIL I

FAGOR



DESPIECE

PARTS BREAKDOWNS

ZONA/ZONE SEVERAL DEVICE

LAMINA/DRAWING

QVR/QVF

ITEM	REFERENCIA REFERENCE	DENOMINACIÓN	DENOMINATION	R							RECOMENDED	ELIMINADO ELIMINATED	INTRODUCIDO INTRODUCED	NOTAS / NOTES
				QVR-1 N	QVR-1G N	QVR-2 N	QVR-2G N	QVR-3 N	QVR-3G N	QVF-1 N				
EVAPORATION UNITS / UNIDADES DE EVAPORACIÓN														
TOP PANEL / CABEZAL														
	12199811	TOP PANEL ASSEMBLY	ENSAMBLE CABEZAL	1										
66	12205800	TOP PANEL	CABEZAL	1										
67	12190864	LOCK	CERRADURA	1										
	12199815	TOP PANEL ASSEMBLY	ENSAMBLE CABEZAL		1									
66	12205808	TOP PANEL	CABEZAL		1									
67	12190864	LOCK	CERRADURA		1									
	12199813	TOP PANEL ASSEMBLY	ENSAMBLE CABEZAL			1								
66	12205802	TOP PANEL	CABEZAL			1								
67	12190864	LOCK	CERRADURA			2								
	12199816	TOP PANEL ASSEMBLY	ENSAMBLE CABEZAL				1							
66	12205812	TOP PANEL	CABEZAL				1							
67	12190864	LOCK	CERRADURA				1							
	12199814	TOP PANEL ASSEMBLY	ENSAMBLE CABEZAL					1						
66	12205806	TOP PANEL	CABEZAL					1						
67	12190864	LOCK	CERRADURA					3						
68	12190861	TOP FULL HINGE	BISAGRA CABEZAL COMPLETA					0.2						
	12199817	TOP PANEL ASSEMBLY	ENSAMBLE CABEZAL						1					
66	12209245	TOP PANEL	CABEZAL						1					
67	12190864	LOCK	CERRADURA						3					
68	12190861	TOP FULL HINGE	BISAGRA CABEZAL COMPLETA						0.2					
69	13002382	FAGOR STICKER	PEGATINA G. CONCEPT PWC						1					
	12199811	TOP PANEL ASSEMBLY	ENSAMBLE CABEZAL							1				
66	12205800	TOP PANEL	CABEZAL							1				
67	12190864	LOCK	CERRADURA							1				
68	13002382	FAGOR STICKER	PEGATINA G. CONCEPT PWC							1				
69	12189999	COVER HINGE	TAPA BISAGRA							1				
	12199813	TOP PANEL ASSEMBLY	ENSAMBLE CABEZAL								1			
66	12205802	TOP PANEL	CABEZAL								1			
67	12190864	LOCK	CERRADURA								2			
68	13002382	FAGOR STICKER	PEGATINA G. CONCEPT PWC								1			
	12199814	TOP PANEL ASSEMBLY	ENSAMBLE CABEZAL									1		
66	12205806	TOP PANEL	CABEZAL									1		
67	12190864	LOCK	CERRADURA									3		
68	12190861	TOP FULL HINGE	BISAGRA CABEZAL COMPLETA										0.2	
69	13002382	FAGOR STICKER	PEGATINA G. CONCEPT PWC										1	
CONTROLLERS & OTHERS / CONTROLES Y OTROS														
70	12190478	CARELCONTROLLER	CONTROL CAREL	1	1	1	1	1	1	1			X	
71	12190477	CARELCONTROLLER FREEZER	CONTROL CAREL CONGELADOR							1	1	1	X	
77	12190580	DRIVER LED	DRIVER P/ILUMINACION LED		1		2		1				X	
78	12111499	RELAY	RELEVADOR			1	1	1	1	1	1	1	X	
SHELVES/ ESTANTES														
79	12190899	PILLASTER 43"	PILASTER 43"	4	4	8	8	12	12	4	8	12		
80	12188096	STAINLESS STEEL CLIP	CLIP SS ACERO INOXIDABLE	12	12	24	24	36	36	12	24	36		
81	12188095	FLAT RACK A-700	PARRILLA A-700	3	3	6	6			3	6			
82	12190646	FLAT RACK A-1400	PARRILLA A-1400					9	9			9		
83	12189965	BOTTOM SHELF	REJILLA INFERIOR							2	4	6		
97	12217771	VALVE	VALVULA	1	1					1	1	1		

FAGOR



CUSTOMER SERVICE

Fagor Commercial, Inc.
13105NW 47thAve
Miami, Fl. 33054
Tel:(305) 7790170
Fax:(305)7790173
1-866-463-2467
www.Fagorcommercial.com

Circuito Exportación N° 201
Parque Industrial Tres Naciones
San Luís Potosí, S.L.P. México
C.P. 78395
Planta S.L.P.: + 52 (444) 137 0500
México D.F.: + 52 (55) 5082 5825

SERVICIO TECNICO