

ONNERA GROUP	FORMATO	CLAVE:	FID-16
	DESPIECES	FECHA DE REVISIÓN:	17-Feb-2015
		NO. REVISIÓN:	A

Control de Documento

A. Revisiones y aprobaciones del documento.

Actividad	Puesto	Nombre	Fecha
Elaboró:	Ing. de Producto	Raúl Santiago	03/07/15
Revisó:	Dir. Calidad y Producto	Alejandro Montelongo	03/07/15
Aprobó:	Dir. Calidad y Producto	Alejandro Montelongo	03/07/15

B. Descripción de cambios

Fecha	Rev.	Solicitante	Naturaleza del cambio
14/12/15	A	Daniel Perez	Actualizar Motor Electronico, Resistencia Goteo e Imagen Desague 60° / Updated Electronical Fan, Heater & Fitting.

NO IMPRIMIR 1^{er} HOJA "CONTROL DOCUMENTAL"

IMPRIMIR APARTIR DE LA 2^{DA} HOJA

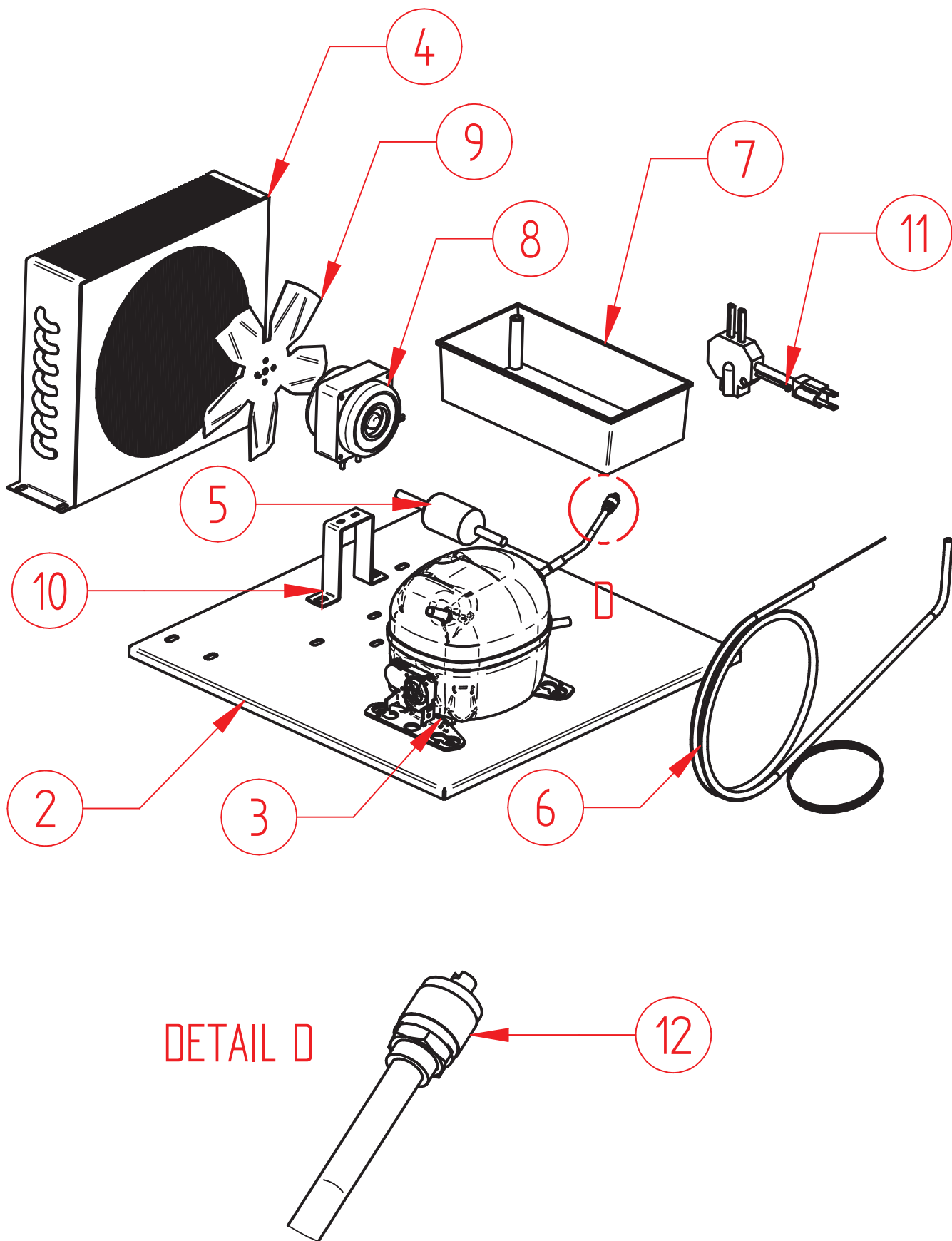

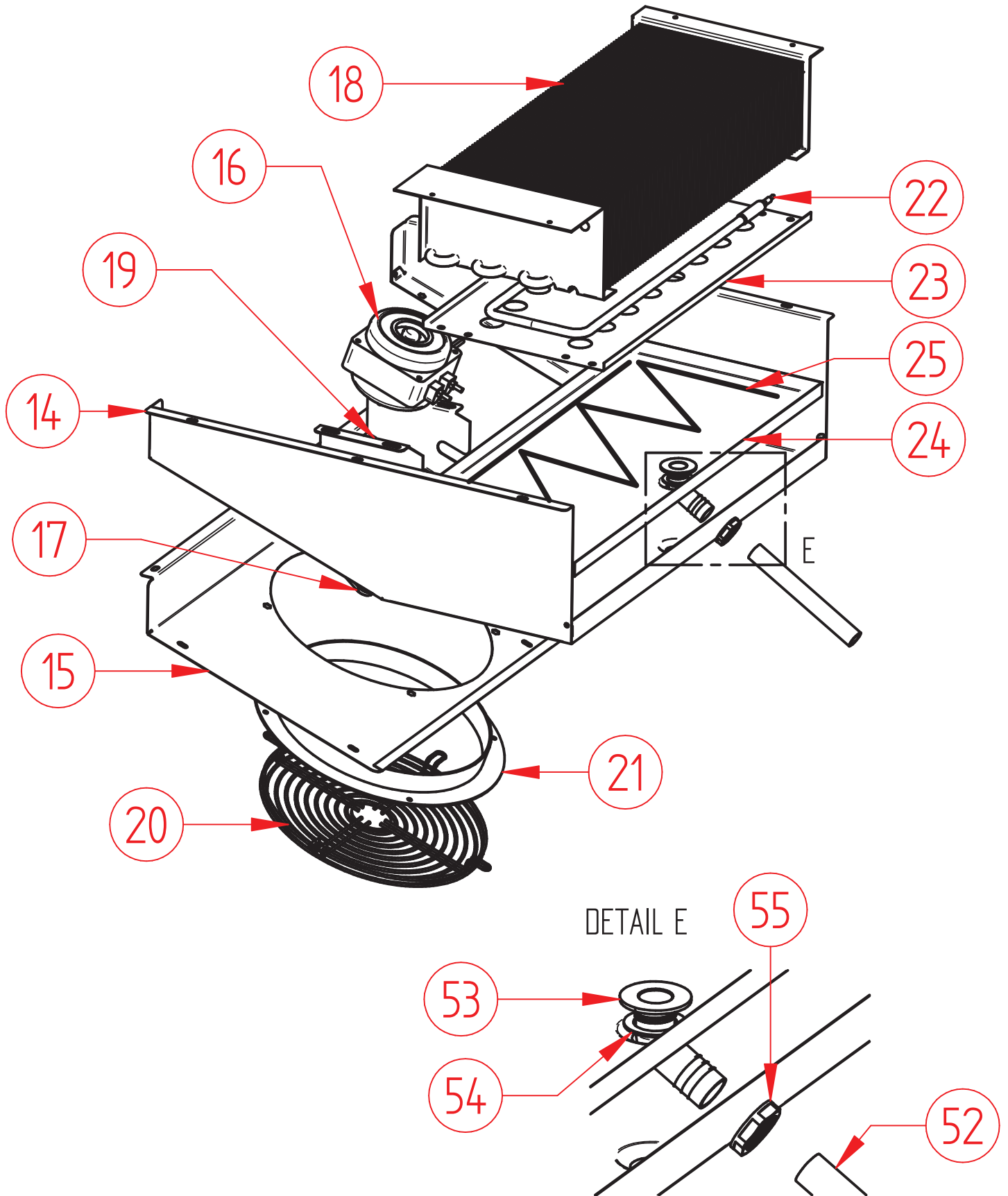

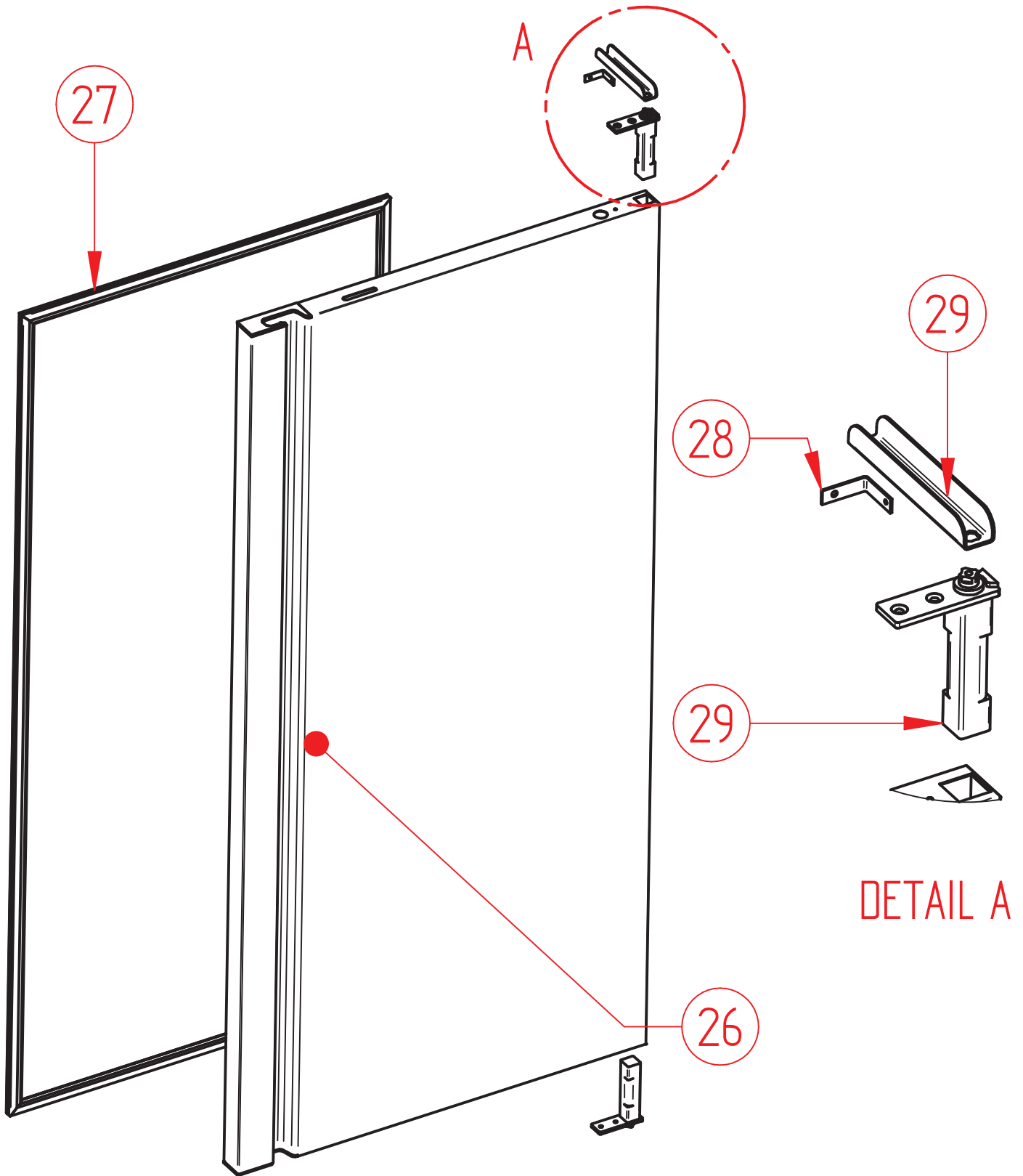

DETAIL A

FAGOR



DESPIECE

PARTS BREAKDOWNS

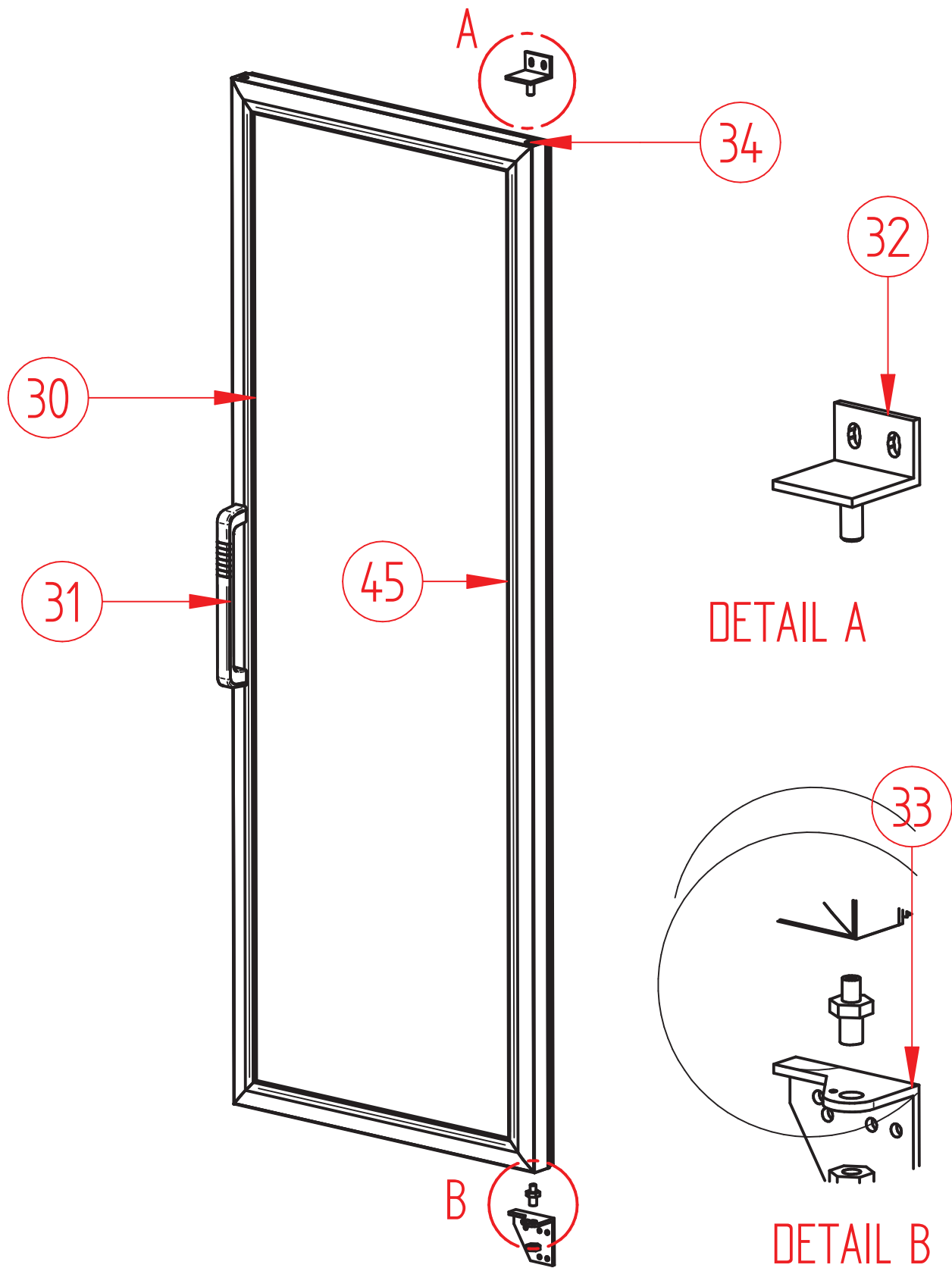

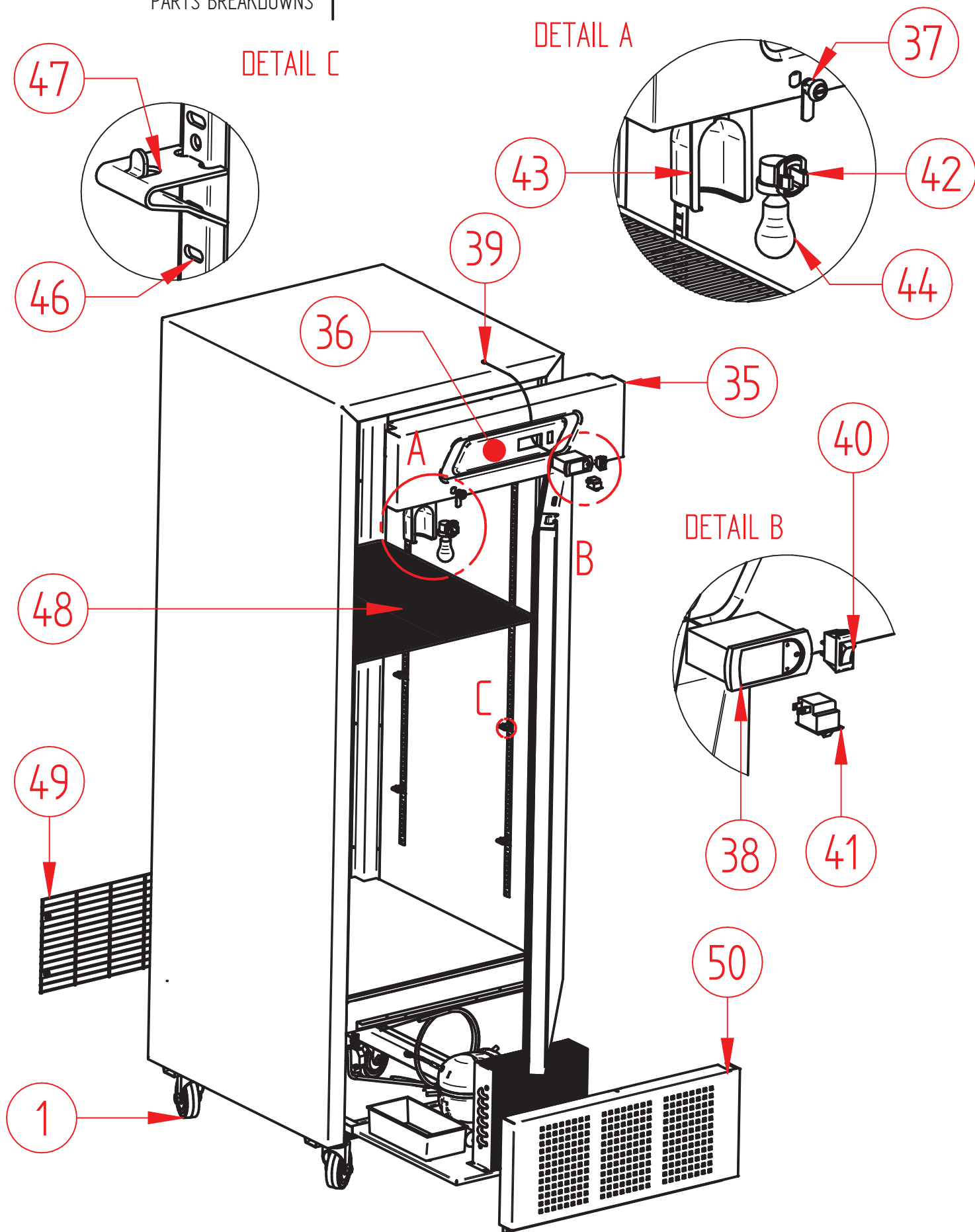

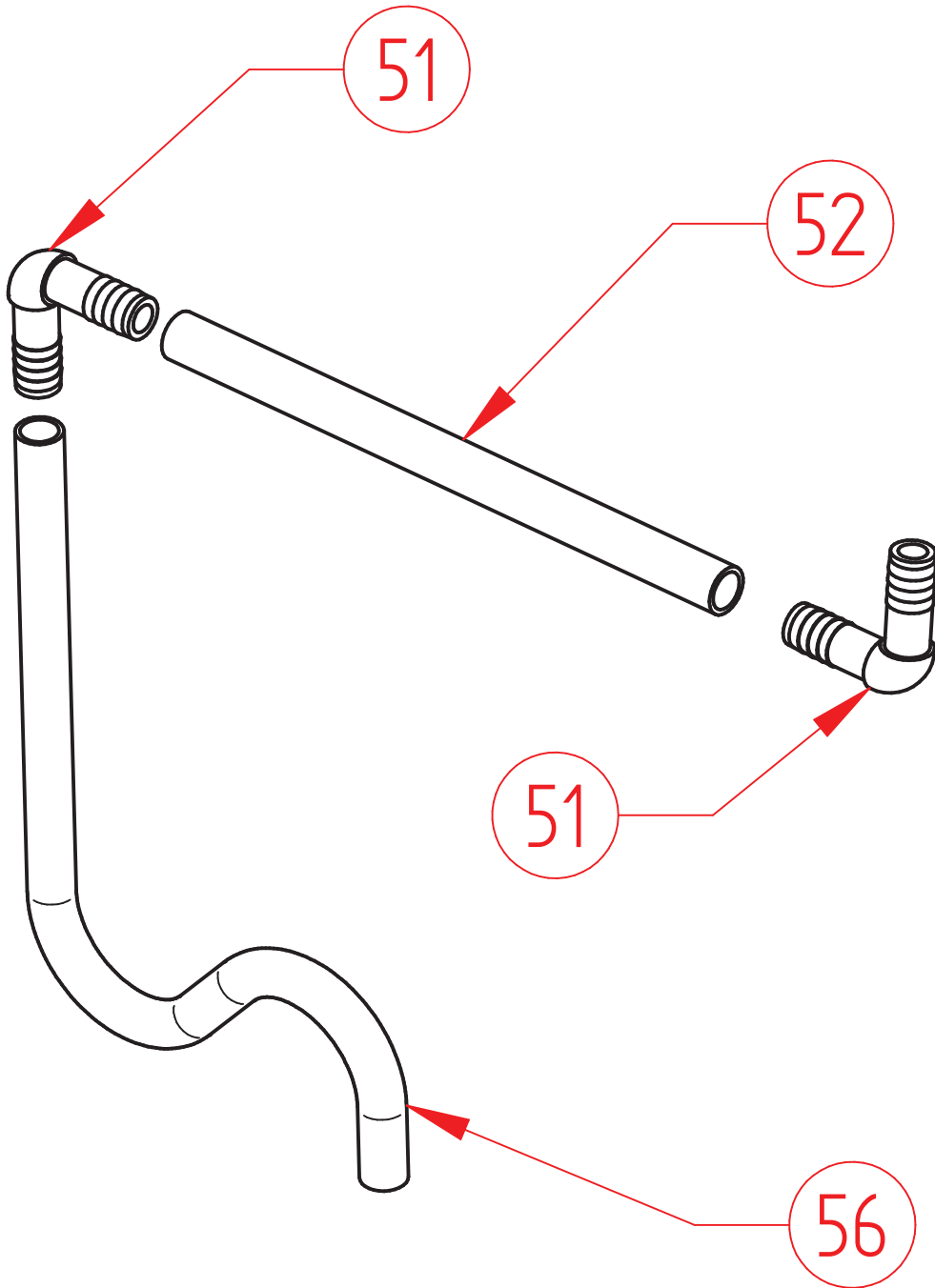

QVF-1_G_QVF-2



* APPLY TO "ELEC" MODELS

# ITEM	CODE CÓDIGO	DESCRIPTION	DESCRIPCIÓN	QVF-1	QVF-1G	QVF-2
Castors & Legs / Ruedas & Tacones						
	M10505M0003	CAST KIT	KIT DE RUEDAS	1	1	1
	603301M0140	CASTER TOOL	LIAVE PARA RUEDAS	1	1	1
1	603313M0002	CASTER 4" W/BRAKE	RUEDA DELANTERA C/F Ø 4"	2	2	2
	603313M0001	CASTER 4" WO/ BRAKE	RUEDA DELANTERA S/F Ø4"	2	2	2
	603301M0130	SHIMS	PLATINA NIVELADORA	8	8	8
Condensing Units / Unidades de Condensación						
	A17301M0034	CONDENSING UNIT	UNIDAD CONDENSACION	1	1	
2	A10917M0295	DECK	BANCADA	1	1	
3	602101M0017	COMPRESSOR 115V	COMPRESOR 115V	1	1	
	602101M0036	START KIT	KIT ARRANQUE	1	1	
4	602902M0011	CONDENSER	CONDENSADOR	1	1	
5	604701M0005	FILTER	FILTRO	1	1	
6	600701M0014	HEAT EXCHANGER	INTERCAMBIADOR	1	1	
7	6003010023	DRAIN PAN	BANDEJA EVAPORACION	1	1	
8	602105M0003	FAN	VENTILADOR 10W	1	1	
	602105M0030 *	ELECTRONICAL FAN	MOTOR ELECTRONICO	1	1	
9	602105M0014	FAN PLASTIC BLADE	ASPA PLÁSTICA 9"	1	1	
10	603301M0156	FAN BRACKET	SOPORTE PORTERIA	1	1	
11	M12145M0001	POWER CORD (SPIDER HUB)	CORDON TOMACORRIENTE	1	1	
12	6021310003	SERVICE VALVE	VALVULA OBUS	1	1	
13	M10702M0013	CAP TUBE	TUBO CAPILAR	1	1	
	A17301M0043	CONDENSING UNIT	UNIDAD CONDENSACION			1
2	A10917M0295	DECK	BANCADA			1
3	602101M0100	COMPRESSOR 115V	COMPRESOR 115V			1
3	602101M0106	START KIT	KIT ARRANQUE			1
4	602902M0011	CONDENSER	CONDENSADOR			1
5	604701M0005	FILTER	FILTRO			1
6	600701M0015	HEAT EXCHANGER	INTERCAMBIADOR			1
7	6003010023	DRAIN PAN	BANDEJA EVAPORACION			1
8	602105M0003	FAN	VENTILADOR 10W			2
	602105M0030 *	ELECTRONICAL FAN	MOTOR ELECTRONICO			2
9	602105M0014	FAN PLASTIC BLADE	ASPA PLÁSTICA 9"			1
10	603301M0156	FAN BRACKET	SOPORTE PORTERIA			1
11	M12145M0001	POWER CORD (SPIDER HUB)	CORDON TOMACORRIENTE			1
12	6021310003	SERVICE VALVE	VALVULA OBUS			1
13	M10702M0014	CAP TUBE	TUBO CAPILAR			1
Evaporation Units / Unidades de Evaporación						
	A17101M0082	EVAPORATION UNIT	UNIDAD EVAPORACION	1	1	
14	A10905M0463	EVAPORATION TRAY	BANDEJA EVAPORACION	1	1	
15	A10905M0464	EVAPORATION TRAY COVER	TAPA BANDEJA EVAPORACION	1	1	
16	602105M0003	FAN	VENTILADOR 10W	1	1	
	602105M0030 *	ELECTRONICAL FAN	MOTOR ELECTRONICO	1	1	
17	600305M0074	PLASTIC BLADE	ASPA PLASTICA 8"	1	1	
18	602901M0019	EVAPORATOR COIL	EVAPORADOR	1	1	
19	A10905M0461	FAN BRACKET	SOPORTE MOTOR	1	1	
-	A10905M0221	TEMP SENSOR BRACKET	PROTECTOR SONDA	1	1	
20	602713M0002	FAN GRID	REJILLA MOTOR	1	1	
21	600709M0003	GRID SUPPORT	SOPORTE REJILLA	1	1	
22	602125M0069	HEATER	RESISTENCIA 350W	1	1	
23	A10905M0477	HEATER COVER	CUBRERESITENCIA	1	1	
24	A10905M0493	COLECTER TRAY	BANDEJA RECOLECTORA	1	1	
25	602125M0014	DRAIN HEATER	RESITENCIA GOTEO	1	1	

QVF-1_G_QVF-2



* APPLY TO "ELEC" MODELS

# ITEM	CODE CÓDIGO	DESCRIPTION	DESCRIPCIÓN	QVF-1	QVF-1G	QVF-2
A17101M0081						
		EVAPORATION UNIT	UNIDAD EVAPORACION			1
14	A10905M0459	EVAPORATION TRAY	BANDEJA EVAPORACION			1
15	A10905M0460	EVAPORATION TRAY COVER	TAPA BANDEJA EVAPORACION			1
16	602105M0003	FAN	VENTILADOR 10W			2
	602105M0030 *	ELECTRONICAL FAN	MOTOR ELECTRONICO			2
17	600305M0074	PLASTIC BLADE	ASPA PLASTICA 8"			2
18	602901M0023	EVAPORATOR COIL	EVAPORADOR			1
19	A10905M0461	FAN BRACKET	SOPORTE MOTOR			2
	A10905M0221	TEMP SENSOR BRACKET	PROTECTOR SONDA			1
20	602713M0002	FAN GRID	REJILLA MOTOR			2
21	600709M0003	GRID SUPPORT	SOPORTE REJILLA			2
22	602125M0073	HEATER	RESISTENCIA 600W			1
23	A10905M0475	HEATER COVER	CUBRERESISTENCIA			1
24	A10905M0492	COLECTER TRAY	BANDEJA RECOLECTORA			1
25	602125M0035	DRAIN HEATER	RESITENCIA GOTEO			1
Doors & O thers / Puertas & Otros						
A16901M0159						
		DOOR KIT	ENSAMBLE DE PUERTAS	1		2
26	A10913M0544	DOOR	PUERTA	1		1
27	604501M0021	GASKET	BURLETE	1		1
28	603301M0176	FIXING BRACKET	FIJACION BISAGRA	2		2
29	6033010003	CARTRIDGE	BISAGRA DOBLE MUELLE	2		2
A16905M0004						
		CRYSTAL DOOR KIT	ENSAMBLE DE PUERTAS CRISTAL		1	
30	603107M0017	DOOR	PUERTA		1	
31	600301M0020	HANDLE	JALADERA		1	
32	A10913M0539	TOP HINGE	BISAGRA SUPERIOR		1	
33	A10913M0540	BOTTOM HINGE	BISAGRA INFERIOR		1	
34	600305M0133	NYLON BUSHING	BUJE NYLON		1	
Top Panel /Cabezal						
35	A10913M0170	TOP PANEL	CABEZAL	1		
	A10913M0643	TOP PANEL	CABEZAL		1	
	A10913M0167	TOP PANEL	CABEZAL			1
	A10913M0564	TOP PANEL	CABEZAL			
36	602301M0054	FAGOR STICKER	ETIQUETA FAGOR	1	1	1
37	603301M0056	LOCK	CERRADURA	1	1	2
Controllers & Other / Controles & Otros						
38	602135M0045	CARELCONTROLLER	CONTROL CAREL	1	1	1
39	602135M0026	TEMP SENSOR	SONDA CAREL	2	2	2
40	602113M0001	ROCKER SWITCH	INTERRUPTOR GENERAL	1	1	1
41	602113M0002	DOOR LIGHT SWITCH	INTERRUPTOR PUERTA ILUMINACION	1	1	2
42	602125M0047	LIGHT SOCKET	SOCKET	1		1
43	600305M0072	LIGHT PROTECTOR	PANTALLA FOCO	1		1
44	602125M0048	LIGHT BULB	FOCO INCANDESCENTE	1		1
45	602129M0022	LED LIGHT	ILUMINACION LED		1	
	602129M0023	DRIVER LED	DRIVER P/ ILUMINACION LED		1	
Shelves /Parrilas						
46	603305M0027	PILLASTER 43"	PILASTER 43"	4	4	8
47	603301M0005	STAINLESS STEEL CLIP	CLIP SS ACERO INOXIDABLE	12	12	24
48	602701M0001	FLAT RACK	PARRILLA	3	3	6

QVF-1_G_QVF-2

* APPLY TO "ELEC" MODELS



# ITEM	CODE CÓDIGO	DESCRIPTION	DESCRIPCIÓN	QVF-1	QVF-1G	QVF-2
Panels /Rejillas						
49	602701M0028	BACK PANEL	REJILLA POSTERIOR	1	1	2
	A10913M0193	FRONTAL PANEL	REJILLA MOTOR	1		
50	A10913M0660	FRONTAL PANEL	REJILLA MOTOR		1	
	A10913M0211	FRONTAL PANEL	REJILLA MOTOR			1
	A10913M0218	FRONTAL PANEL	REJILLA MOTOR			
	603301M0166	L SHAPE BRACKET	ESCUADRA FIJACION	2	2	2
Drain /Drenaje						
51	600717M0012	DRAIN HOSE KIT	KIT MANGUERA DESAGÜE	1	1	1
52	600717M0088	DRAIN HOSE 5/8"	MANGUERA DESAGUE 5/8"	0.5	0.5	0.5
53	600717M0103	DRAIN FITTING 60°	CODO DESAGUE 60°	1	1	1
54	6003010051	PLASTIC SEAL	JUNTA GOMA	1	1	1
55	600301M0087	NYLON NUT	TUERCA 7/8 NYLON	1	1	1
56	600717M0070	RIGID HOSE	MANGUERA RIGIDA	1	1	1

FAGOR



CUSTOMER SERVICE

Fagor Commercial, Inc.
13105NW 47thAve
Miami, FL. 33054
Tel:(305) 7790170
Fax:(305)7790173
1-866-463-2467
www.Fagorcommercial.com

Circuito Exportación N° 201
Parque Industrial Tres Naciones
San Luís Potosí, S.L.P. México
C.P. 78395
Planta S.L.P.: + 52 (444) 137 0500
México D.F.: + 52 (55) 5082 5825

SERVICIO TECNICO