

MODELOS / MODELS

CO-400 W

CO-402 W

LAVAVASOS
GLASSWASHERS

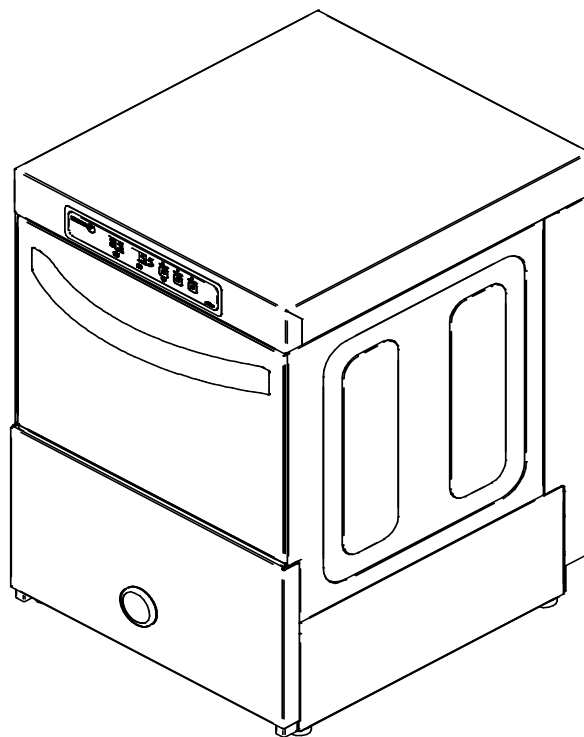

ENERO 2021 *JANUARY*
Revisado ENERO 2021 *JANUARY updated*

Despiece técnico CO-400_402 W /
Spare Parts CO-400_402 W

FAGOR 

REFERENCIAS / REFERENCES

19073543 CO-400 W B DD CA 220-240V 1 60Hz
19073544 CO-402W B DD CA 220-240V 1 60Hz

LAVAVASOS
GLASSWASHERS

Despiece técnico CO-400_402 W /
Spare Parts CO-400_402 W

FAGOR 

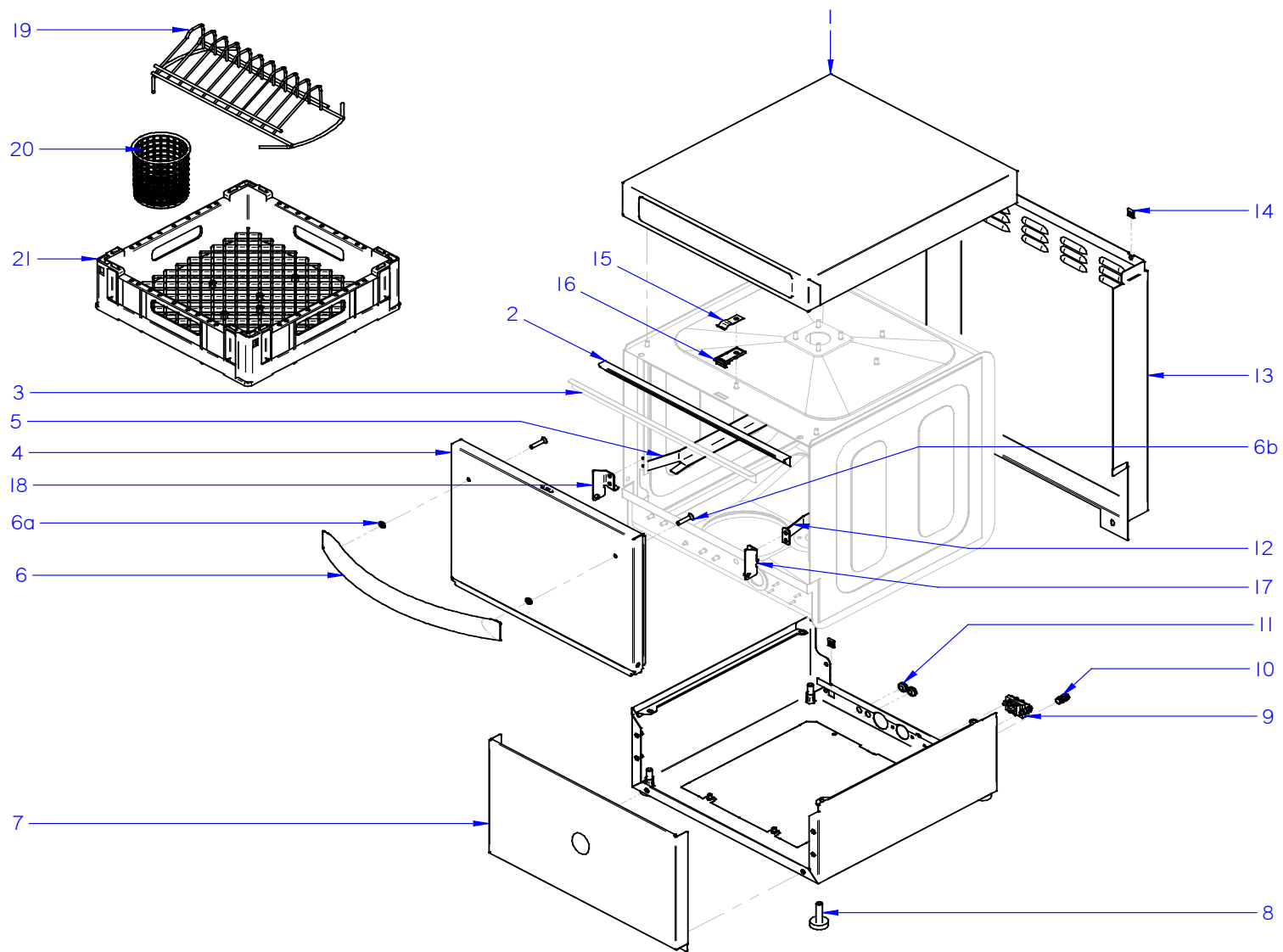

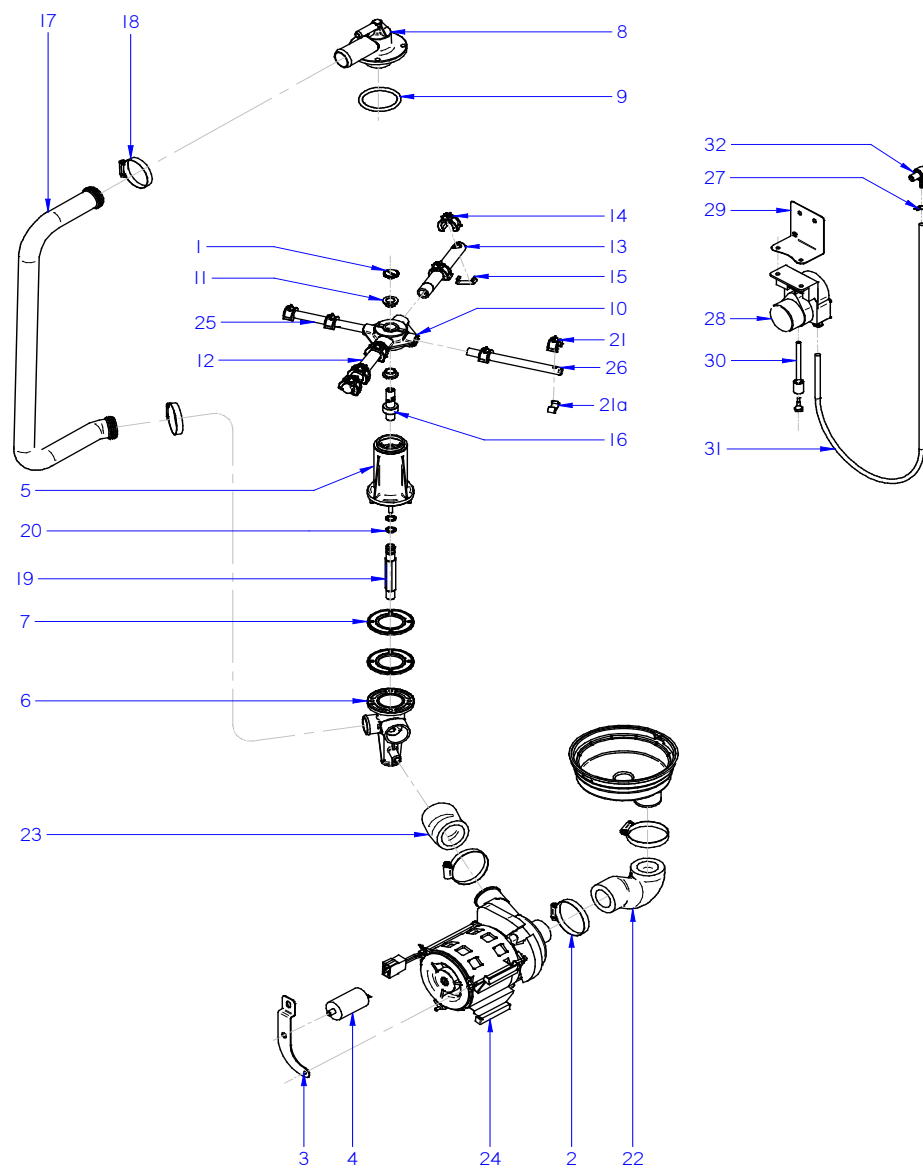

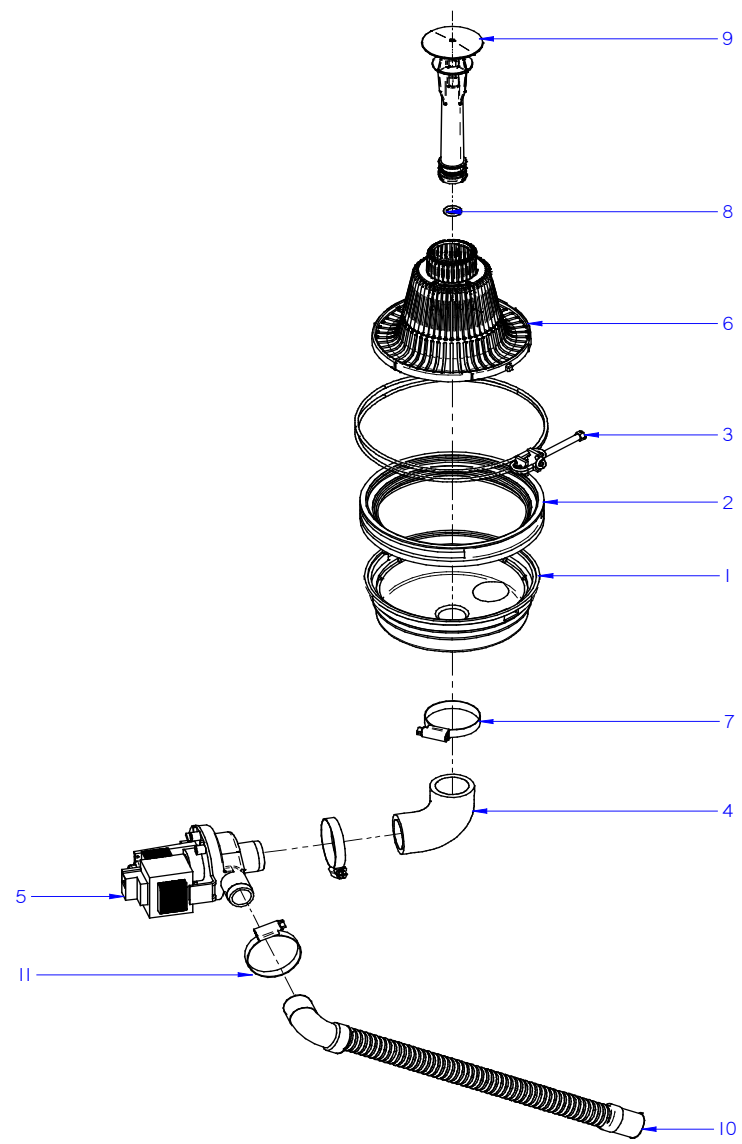

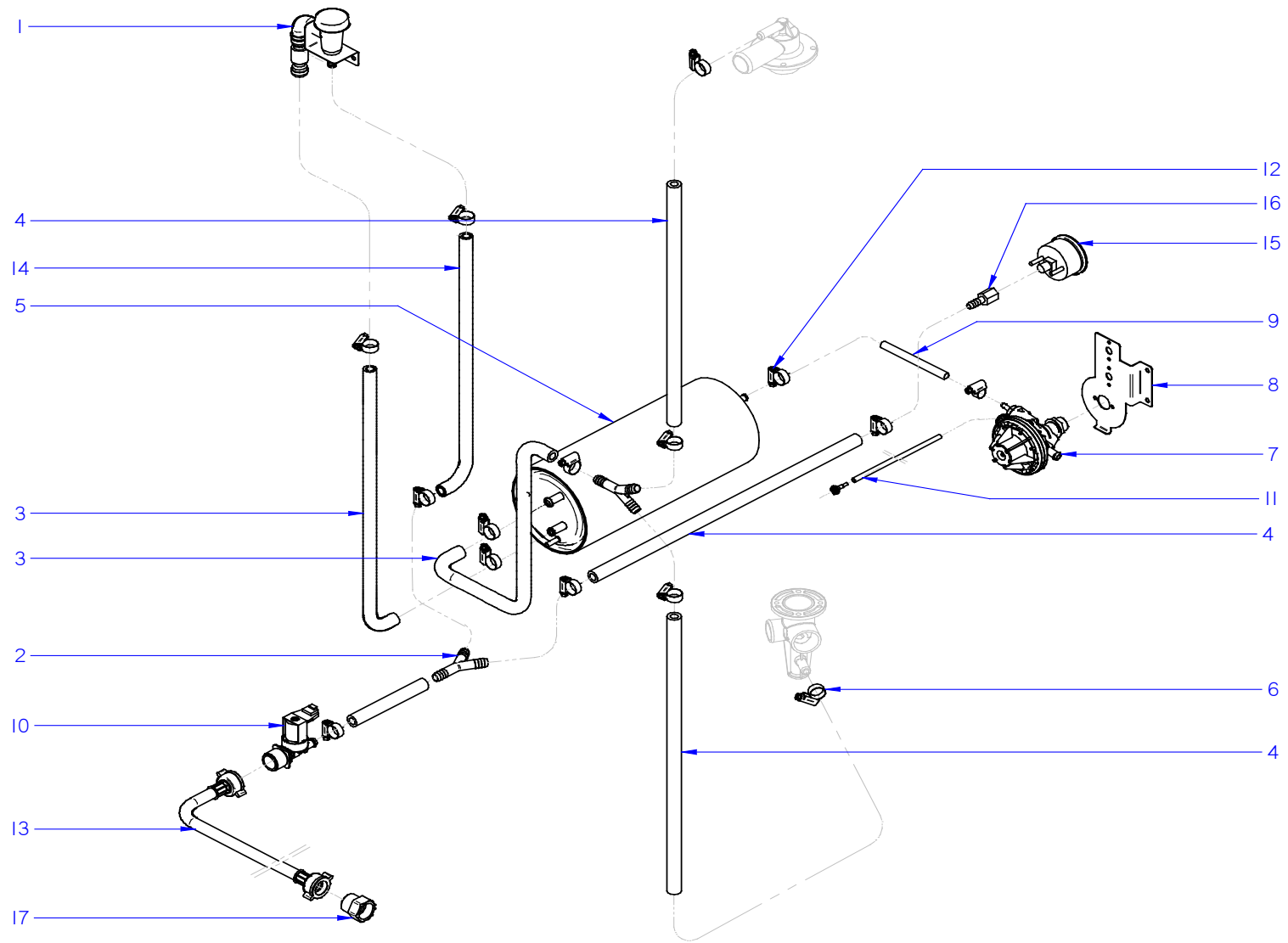

APARATO /
APPLIANCE

LAVAVAJILLAS / DISHWASHER

ZONA / ZONE

ACLARADO / RINSE

ITEM	CODIGO REFERENCE	DENOMINACIÓN	DENOMINATION	CO-400 W	CO-402 W												RECOMENDADOS RECOMMENDED	HASTA UNTIL	DESDE SINCE	NOTAS / NOTES
1	12280049	VALVULA ANTIRRETORNO W	NON-RETURN VALVE W	1	1												X			
2	12023511	RACORD EN Y	Y FITTING	2	2															
3	12245966	CONDUCTO CALDERIN-RACORD	BOILER-FITTING PIPE	2	2															
4	11000083	TUBO GOMA NEGRA D 17x10	BLACK RUBBER PIPE D 17x10	1	1															
5	12049602	CALDERIN	BOILER	1	1															
6	12010036	ABRAZADERA 12-20	12-20 CLAMP	14	14															
7	12133010	DOSIFICADOR ABRILLANTADOR	RINSE-AID DISPENSER	1	1															
8	12132302	SOPORTE TERMOSTATOS	THERMOSTATS SUPPORT	1	1															
9	11002150	TUBO EPDM TRENZADO 6x12	EPDM BRAIDED PIPE 6x12	1	1															
10	12025161	E.V.SIMPLE 220V. 50/60Hz	SIMPLE ELECTROVALVE	1	1												X			
11	12265502	CONDUCTO ABRILLANTADOR	RINSE AID PIPE	1	1															
12	12240495	ABRAZADERA 13-14	CLAMP 13-14	2	2															
13	12025198	MANGUERA ENTRADA AGUA	WATER INLET HOSE	1	1															
14	12245967	CONDUCTO EV-ANTIRRETORNO	EV-NON-RETURN PIPE	1	1															
15	12115146	MANOMETRO	MANOMETER	1	1															
16	12115147	ADATADOR MANOMETRO	MANOMETER ADAPTER	1	1															
17	12023860	ADAPTADOR 3/4	3/4 FITTIING	1	1															

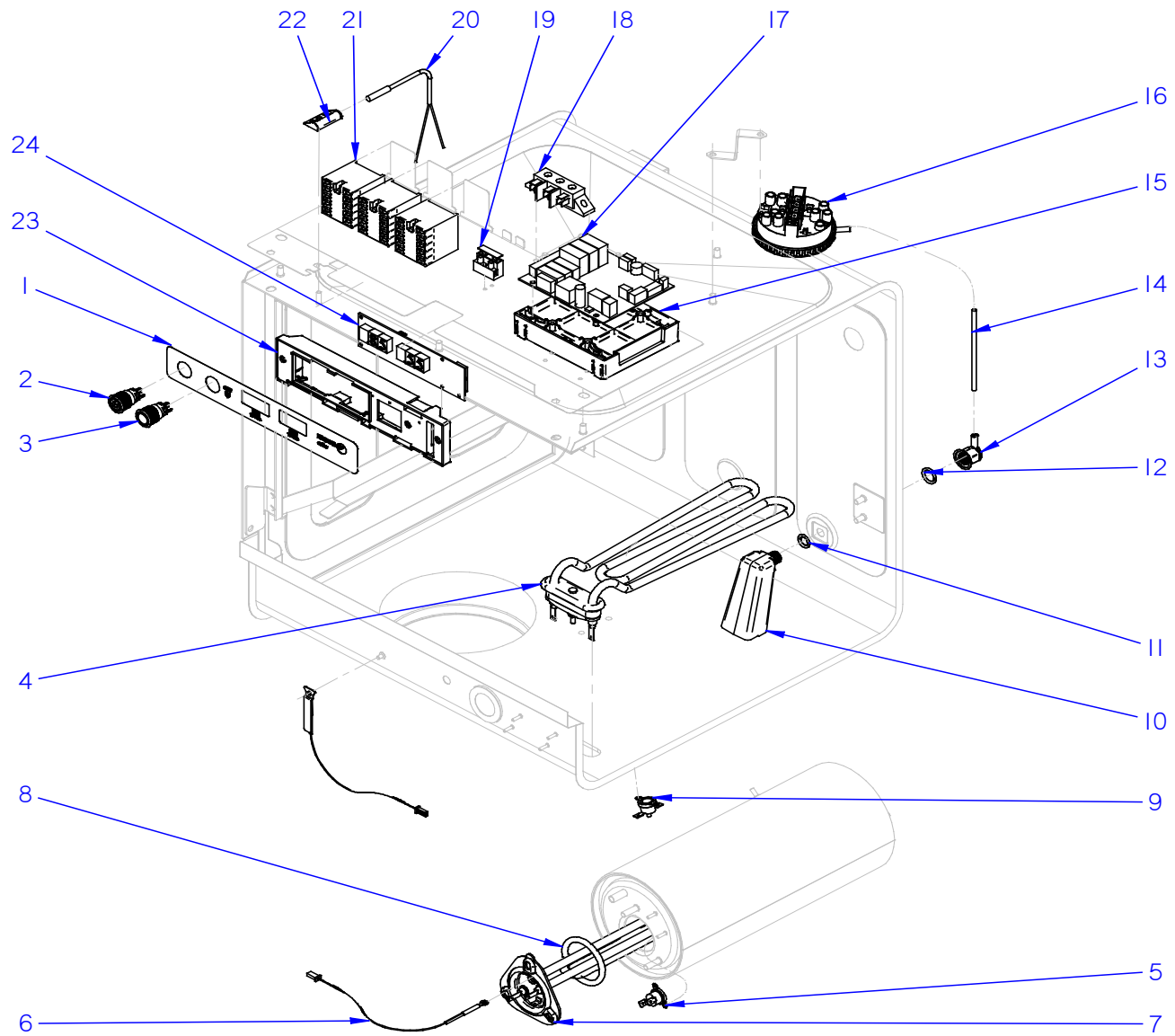

APARATO /
APPLIANCE

LAVAVAJILLAS / DISHWASHER

ZONA / ZONE

ELECTRICO / ELECTRIC

ITEM	CODIGO REFERENCE	DENOMINACIÓN	DENOMINATION	CO-400 W												RECOMENDADOS RECOMMENDED	HASTA UNTIL	DESDE SINCE	NOTAS / NOTES
1	12242577	EMBELLECEDOR CO-400_500 W	STICKER CO-400_500 W	1											X				
2	12242881	BOTON DE ENCENDIDO	POWER ON BUTTON	1											X				
3	12241256	BOTON START	START BUTTON	1											X				
4	12090524	RESISTENCIA TANQUE 2 kW	TANK HEATING ELEMENT 2 kW	1											X				
5	12096597	TERMOSTATO DE SEGURIDAD 110 °C	SAFETY THERMOSTAT 110 °C	1											X				
6	12025036	SONDA NTC	NTC PROBE	2											X				
7	12093124	RESISTENCIA CALDERIN 2,8 kW	BOILER HEATING ELEMENT 2,8 kW	1											X				PEDIR TAMBIEN LA JUNTA 12102062 / ORDER ALSO THE O-RING 12102062
8	12102062	JUNTA TORICA RESISTENCIA	HEATING ELEMENT O-RING	1											X				
9	12090518	TERMOSTATO DE SEGURIDAD 95 °C	SAFETY THERMOSTAT 95 °C	1											X				
10	12136338	CAMARA PRESOSTATO	PRESSURE SWITCH CHAMBER	1															
11	12009873	JUNTA TORICA 16.01X10.77X2.62	O-RING 16.01X10.77X2.62	1															
12	12009837	JUNTA TORICA 13.94x19.18x2.6	O-RING 13.94x19.18x2.6	1															
13	12091147	RACOR PRESOSTATO	PRESSURE SWITCH FITTING	1															
14	11000066	TUBO GOMA NEGRO D 8*4	BLACK RUBBER PIPE D 8*4	1															
15	12232967	SOPORTE TARJETA DE POTENCIA	POWER BOARD SUPPORT	1															
16	12024981	PRESOSTATO TRIPLE	TRIPLE PRESSURE SWITCH	1											X				
17	12232119	TARJETA DE CONTROL 7 RELES	7 RELAY CONTROL BOARD	1											X				
18	12024382	REGLETA 3 VIAS	3 WAY POWER STRIP	1															
19	12045569	BORNA PORTAFUSIBLES	FUSE HOLDER CONNECTOR	1															
20	12024477	INTERRUPTOR MAGNETICO	MAGNETIC SWITCH	1															
21	12024011	CONTACTOR	CONTACTOR	3											X				
22	12024066	AMARRE INTERRUPTOR MAGNETICO	MAGNETIC SWITCH HOLDER	1															
23	12232530	SOPORTE CONTROL	CONTROL SUPPORT	1															
24	12188440	VISUALIZADOR	DISPLAY	1											X				

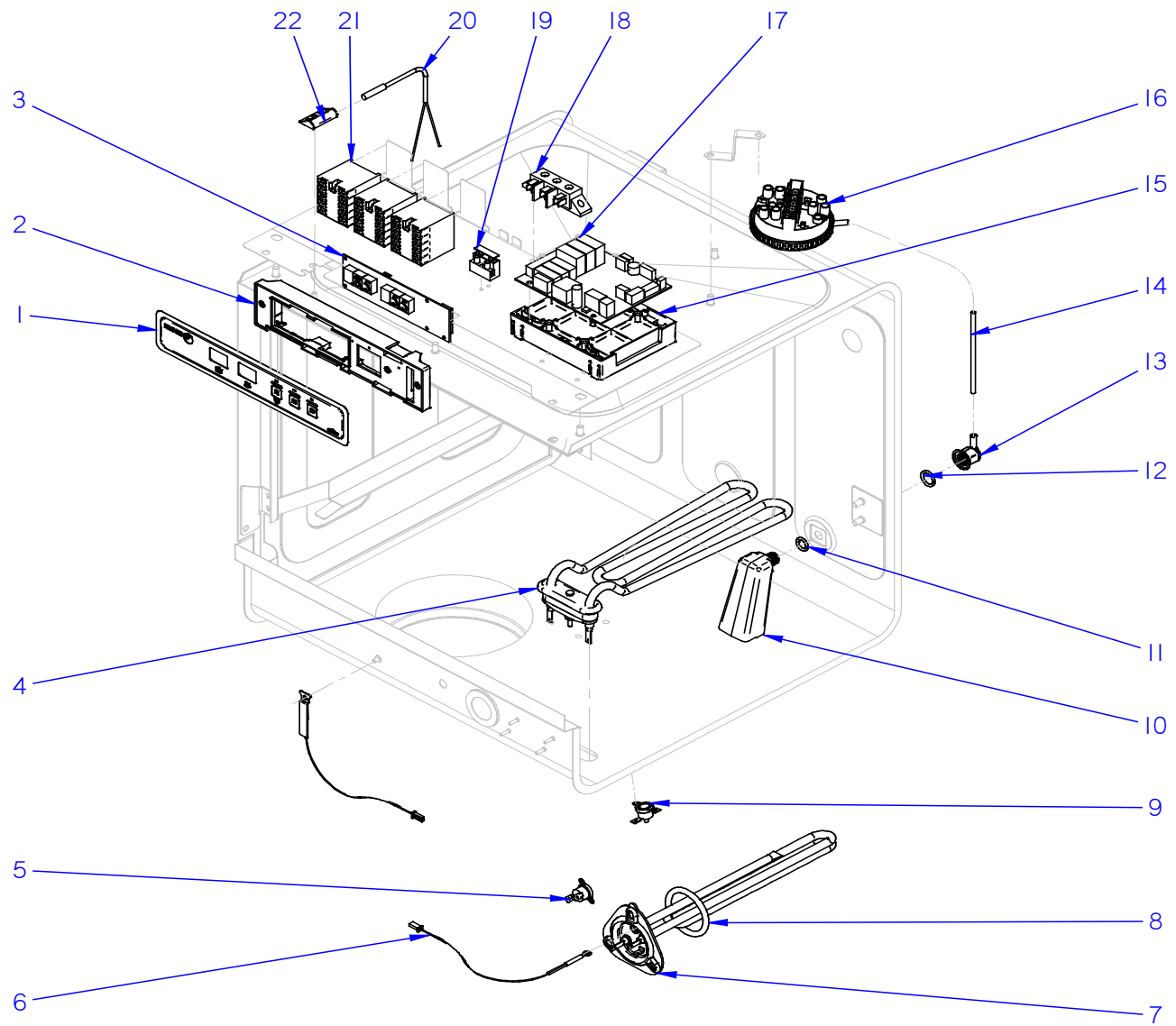

APARATO /
APPLIANCE

LAVAVAJILLAS / DISHWASHER

ZONA / ZONE

ELECTRICO / ELECTRIC

ITEM	CODIGO REFERENCE	DENOMINACIÓN	DENOMINATION	CO-402 W												RECOMENDADOS RECOMMENDED	HASTA UNTIL	DESDE SINCE	NOTAS / NOTES
1	12241172	EMBELLECEDOR 402_502_504_174 W	STICKER 402_502_504_174 W	1												X			
2	12232530	SOPORTE CONTROL	CONTROL SUPPORT	1															
3	12188440	VISUALIZADOR	DISPLAY	1												X			
4	12090524	RESISTENCIA TANQUE 2 kW	TANK HEATING ELEMENT 2 kW	1												X			
5	12096597	TERMOSTATO DE SEGURIDAD 110 °C	SAFETY THERMOSTAT 110 °C	1												X			
6	12025036	SONDA NTC	NTC PROBE	2												X			
7	12093124	RESISTENCIA CALDERIN 2,8 kW	BOILER HEATING ELEMENT 2,8 kW	1												X			PEDIR TAMBIEN LA JUNTA 12102062 / ORDER ALSO THE O-RING 12102062
8	12102062	JUNTA TORICA RESISTENCIA	HEATING ELEMENT O-RING	1												X			
9	12090518	TERMOSTATO DE SEGURIDAD 95 °C	SAFETY THERMOSTAT 95 °C	1												X			
10	12136338	CAMARA PRESOSTATO	PRESSURE SWITCH CHAMBER	1															
11	12009873	JUNTA TORICA 16.01X10.77X2.62	O-RING 16.01X10.77X2.62	1															
12	12009837	JUNTA TORICA 13.94x19.18x2.6	O-RING 13.94x19.18x2.6	1															
13	12091147	RACOR PRESOSTATO	PRESSURE SWITCH FITTING	1															
14	11000066	TUBO GOMA NEGRO D 8*4	BLACK RUBBER PIPE D 8*4	1															
15	12232967	SOPORTE TARJETA DE POTENCIA	POWER BOARD SUPPORT	1															
16	12024981	PRESOSTATO TRIPLE	TRIPLE PRESSURE SWITCH	1												X			
17	12232119	TARJETA DE CONTROL 7 RELES	7 RELAY CONTROL BOARD	1												X			
18	12024382	REGLETA 3 VIAS	3 WAY POWER STRIP	1															
19	12045569	BORNA PORTAFUSIBLES	FUSE HOLDER CONNECTOR	1															
20	12024477	INTERRUPTOR MAGNETICO	MAGNETIC SWITCH	1												X			
21	12024011	CONTACTOR	CONTACTOR	3												X			
22	12024066	AMARRE INTERRUPTOR MAGNETICO	MAGNETIC SWITCH HOLDER	1															

CO 400 W

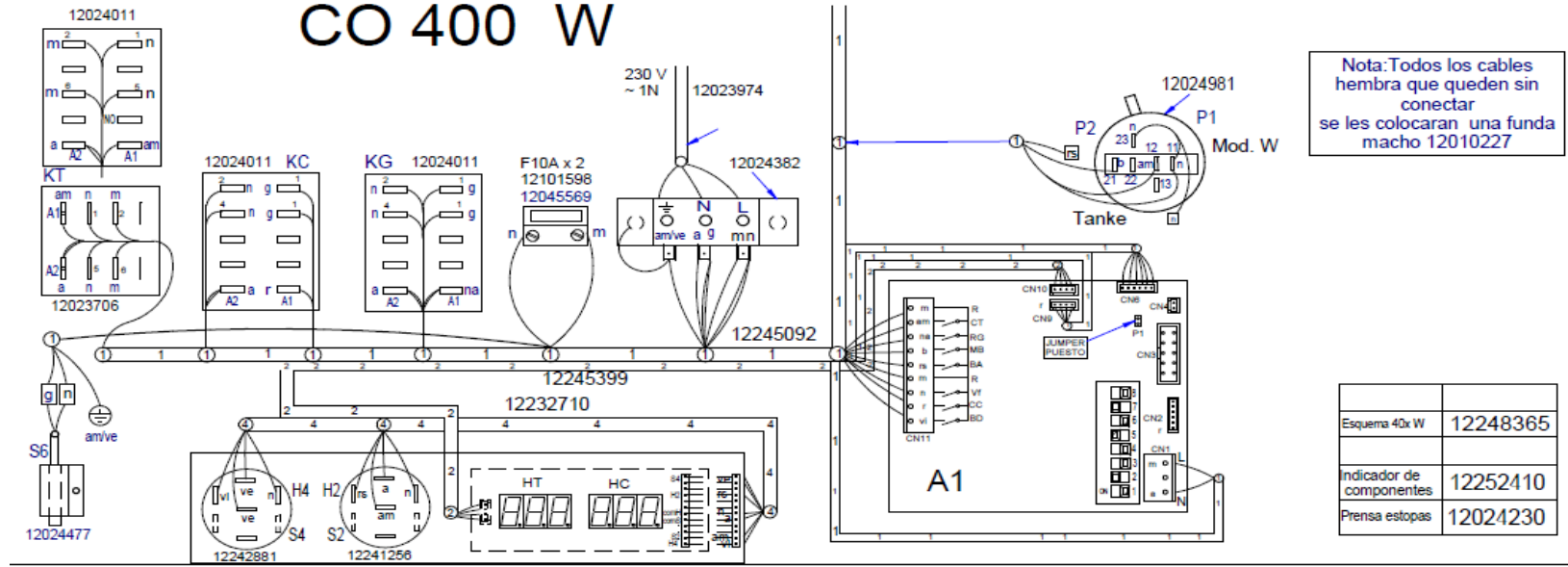

Nota: Todos los cables hembra que quedan sin conectar se les colocaran una funda macho 12010227

Esquema 40x W	12248365
Indicador de componentes	12252410
Prensa estopas	12024230

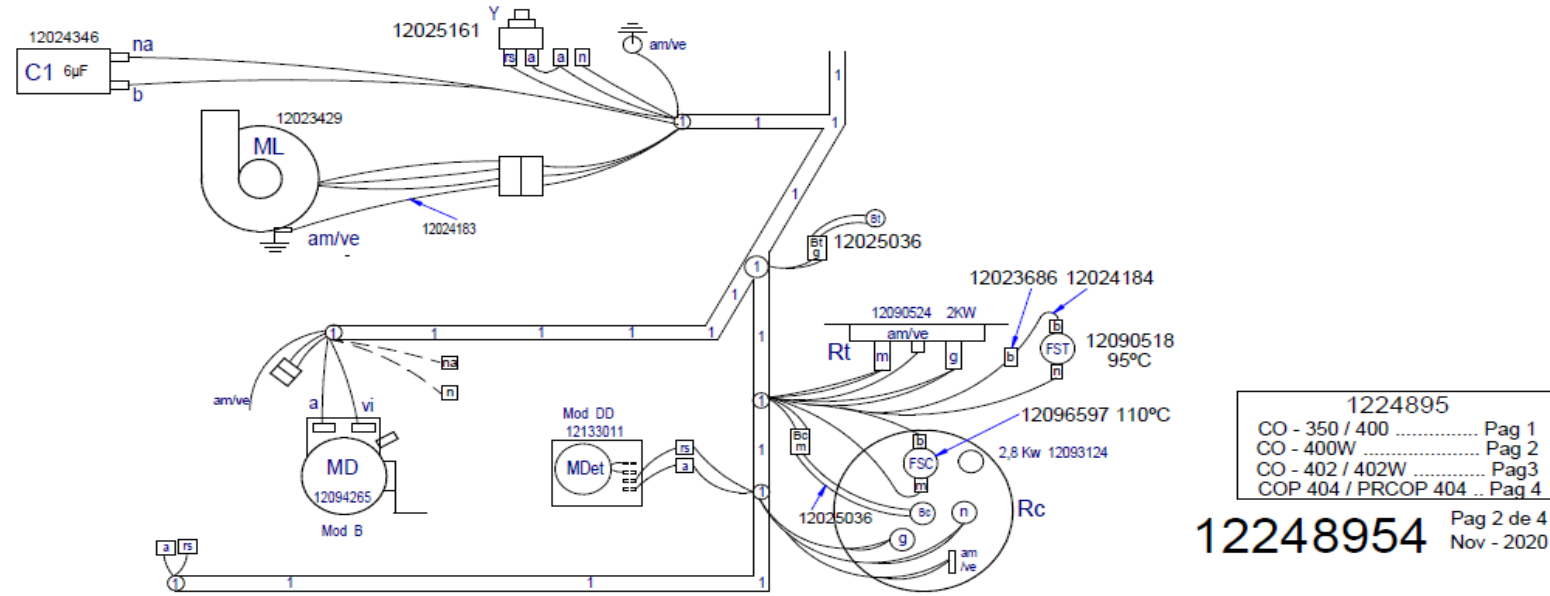

1224895	
CO - 350 / 400	Pag 1
CO - 400W	Pag 2
CO - 402 / 402W	Pag 3
COP 404 / PRCOP 404	Pag 4

12248954 Pag 2 de 4
Nov - 2020

CO 402, 402 W

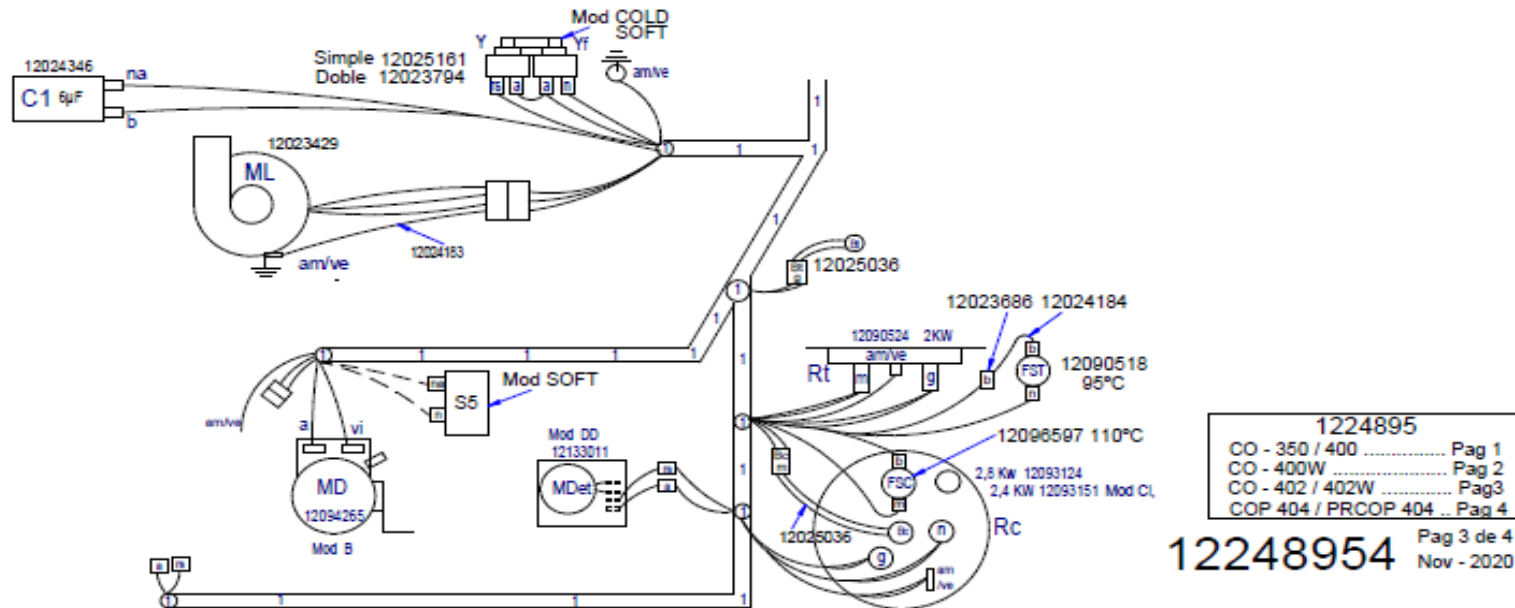
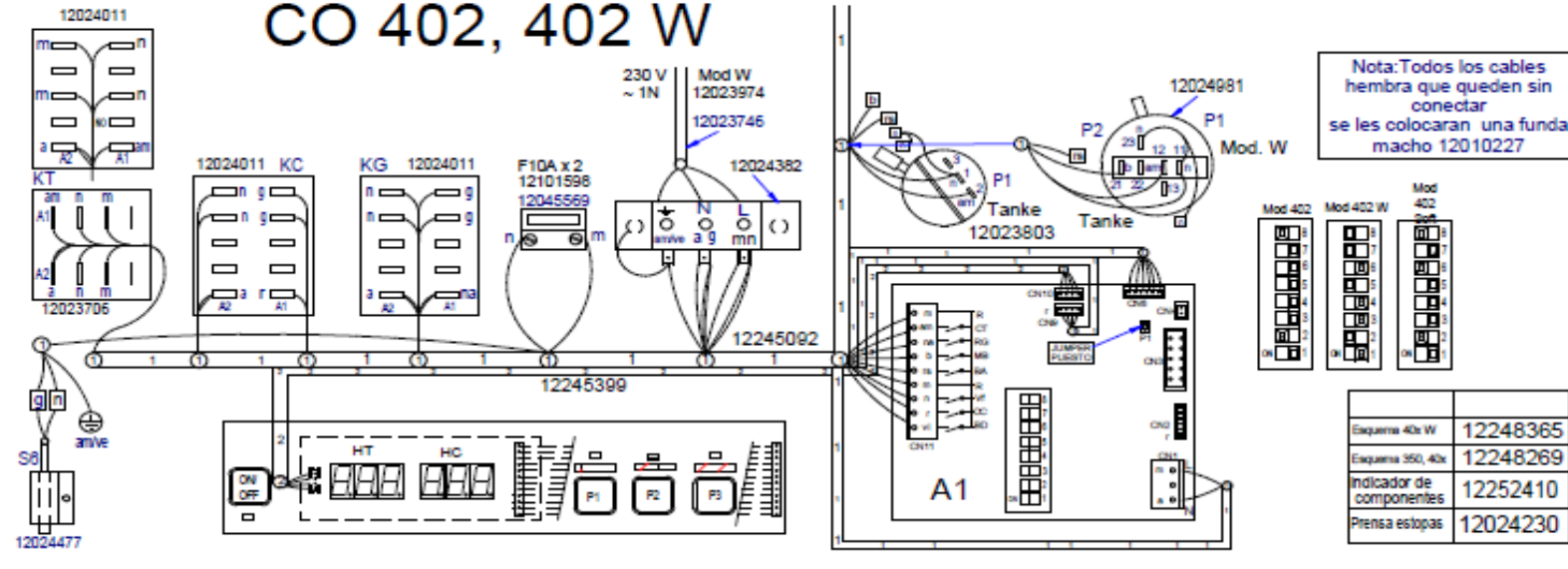

12248954 Pag 3 de 4
Nov - 2020

Simb / LENG	ESPAÑOL	ENGLISH	PORTUGUÉS
A1, A2	Placa Electrónica	Electronic Board	Placa Electrónica
A1-P1	Puente eléctrico / Jumper	Electric Bridge / Jumper	Ligação eléctrica / Jumper
Bc	Sonda Temperatura Calderin	Boiler temperature probe	Sonda de temperatura da caldeira
Bt	Sonda Temperatura Tanque	Tank Temperature Probe	Sonda de temperatura do tanque
C1, C2	Condensador	Capacitor	Capacitor
F	Fusible	Fuse	Fusível
FSC	Termostato Seguridad Calderin	Boiler Safety Thermostat	Termostato de segurança da caldeira
FST	Termostato Seguridad Tanque	Tank Safety Thermostat	Termostato de segurança do tanque
H1, H2, H3	Lampara Ciclo	Cycle Light	Piloto do ciclo
H4	Lampara Encendido	Power On Light	Piloto de máquina ligada
H5 (Modxx4)	Lampara Eff-rinse	Eff-rinse Light	Piloto do Eff-Rinse
H5 (Mod Soft)	Lampara Falta Sal	Missing salt light	Piloto de falta de sal
HC	Display Temperatura Calderin	Boiler temperature Display	Indicador de temperatura da caldeira
HT	Display Temperatura Tanque	Tank Temperature Display	Indicador de temperatura do tanque
Kc	Contacto Calentamiento Calderin	Boiler Heating Contactor	Contacto de aquecimento da caldeira
KG	Relé General	Main Relay	Relé principal
Kt	Contacto Calentamiento Tanque	Tank Heating Contactor	Contacto de aquecimento do tanque
L, L1,L2,L3	Fases Conexión Eléctrica	Power Supply Phases	Fases da conexão elétrica
MABr	Dosificador Abridantador	Rinse Aid Dispenser	Dosificador abridantador
MA	Bomba de Aclarado	Rinse Pump	Bomba de enxágue
MD	Bomba de Desague	Drain Pump	Bomba de descarga
MDet	Dosificador Detergente	Detergent Dispenser	Dosificador de detergente
MHRS	Ventilador HRS	HRS Fan	Ventilador HRS
ML	Bomba de Lavado	Wash Pump	Bomba de lavagem
N	Neutro	Neutral	Neutro
P1	Presostato Tanque	Tank Pressure Switch	Pressostato do tanque
P2	Presostato de seguridad Tanque	Tank Safety Pressure Switch	Pressostato de segurança do tanque
P3	Presostato Calderin	Boiler Pressure Switch	Pressostato da caldeira
PE	Puesta a Tierra	Earth Ground	Terra de proteção
Rc	Resistencia calentamiento Calderin	Boiler Heating Element	Resistência da caldeira
Rt	Resistencia calentamiento Tanque	Tank Heating Element	Resistência do tanque
S1, S2, S3	Pulsador de Programa	Program/Cycle Push button	Botão de programa
S4	Pulsador de Encendido/A pagado	ON/OFF Push button	Botão ON/OFF
S5	Interruptor falta de sal	Lack of salt switch	Interruptor falta de sal
S5 (ADE 125)	Interruptor Generador Agua Caliente	Water Booster Switch	Interruptor water booster
S6	Interruptor de Puerta	Door Switch	Interruptor da porta
SW1	DIP-SWITCH	DIP-SWITCH	DIP-SWITCH
TRF	Transformador	Transformer	Transformador
Y	Electrovalvula Llenado Tanque	Tank Filling Solenoid valve	Electrovalvula Enchimento do tanque
Y2BT	Electrovalvula Regeneracion BT	Regeneration BT Solenoid Valve	Electrovalvula Regeneração BT
Y2D	Electrovalvula Regeneracion Desagüe	Regeneration Drain Solenoid Valve	Electrovalvula Descarga de Regeneração
YSAL	Electrovalvula Regeneracion SAL	Regeneration SALT Solenoid Valve	Electrovalvula Regeneração SAL
Yf	Electrovalvula Llenado Calderin	Boiler Filling Solenoid valve	Electrovalvula Enchimento da caldeira
Z	Filtro EMC	EMC Filter	Filtro EMC
COLOR	COLORES	COLOURS	CORES
BLK, bk, n	Negro	Black	Preto
BLU, bi, a	Azul	Blue	Azul
BRN, bn, m	Marrón	Brown	Marron
GRN, gn, ve	Verde	Green	Verde
GRY, gy, g	Gris	Grey	Cinza
ORG, or, na	Naranja	Orange	Laranja
PNK, pk, rs	Rosa	Pink	Rosa
PRP, pr, vi	Violeta	Purple	Roxo
RED, rd, r	Rojo	Red	Vermelho
WHT, wh, b	Blanco	White	Branco
YEL, yw, am	Amarillo	Yellow	Amarelo
YW/GN, am/ve	Amarillo/verde	Yellow / green	Amarelo/Verde
	NOV - 2020	L 21, 25, 33	12248269