

**CBS-6000 Series Coffee Brewers**

**Models:**

- ▶ **CBS-61H**
- ▶ **CBS-62H**



*Driven To Pioneer Innovation™*

**Table of Contents**

Contact Information .....	2	Warranty.....	8
Product Description/Features .....	2	Principles of Operation.....	8
Technical Data.....	2	Adjustments .....	11
Brewing Specification.....	2	Dispenser Parts .....	14
Weights and Capacities .....	2	LUXUS TPD- 3.0.....	14
Electrical Configuration and Brewing Efficiency .	3	Brewer Parts .....	15
Dimensions & Utility Connections.....	4	CBS 61H & 62H Parts List.....	15
Installation.....	5	Parts Drawing: CBS 61H & 62H .....	17
Operating Procedures .....	7	Troubleshooting.....	18
Service .....	8		

FETCO® and LUXUS® are trademarks or trade names of Food Equipment Technologies Company.

## Contact Information

### FETCO

Food Equipment Technologies Company  
600 Rose Road  
Lake Zurich • IL • 60047-0429 • USA

Internet: [www.fetco.com](http://www.fetco.com)

Phone: (800) 338-2699 (US & Canada)  
(847) 719-3000

Fax: (847) 719-3001

Email: [sales@fetco.com](mailto:sales@fetco.com)  
[techsupport@fetco.com](mailto:techsupport@fetco.com)

---

## Product Description/Features

### CBS-61H - Single Coffee Brewing System

### CBS-62H - Twin Coffee Brewing System

- 3 gallon, thermal, portable, all stainless steel dispensers
- Stainless steel, gourmet size brew baskets
- Brew basket double safety locks
- Open type, leak free dispense system
- Fully automatic, with electronic temperature control
- Mercury type power contactor
- Two level tank drain system
- Total serviceability from the front

#### Optional Features:

- Half batch brewing capability  
(Can be added at any time)
- Color stainless steel finish
- Custom and export voltage

---

## Technical Data

### Brewing Specification

#### Brew Volume:

Full Batch 3 gal. (11.4 lit.)  
Half Batch 1.5 gal. (5.7 lit.)

#### Brew Time:

Full Batch 5 - 5.5 min.  
Half Batch 2.5 - 2.75 min.

*(Allow an extra 2-4 minutes for coffee to finish dripping)*

**Coffee Filter Size:** 20" X 8" - standard FETCO # F004  
18" X 7½" - optional half batch FETCO # F005

#### Temperature:

205°F inside water tank (at sea level)  
195°F ± 5° at sprayhead

#### Bypass Range: 0 to 33%

*(Factory set at 0% unless specified)*

#### Water Requirements:

CBS-61H: 20-75 psig, 1 gpm  
CBS-62H: 20-75 psig, 2 gpm

### Weights and Capacities

Brewer Model	Weight (empty)	Water tank Capacity & Weight		Weight (filled)	Dispenser Weight, ea.	Dispenser Filled, ea.	Total Weight Brewer & Dispensers, Filled
CBS-61H	111 lbs.	8 gal.	66.4 lbs.	177 lbs.	18 lbs.	42.5 lbs.	220 lbs.
CBS-62H	195 lbs.	14 gal.	116.2 lbs.	311.2 lbs.	18 lbs.	42.5 lbs.	397 lbs.

## Electrical Configuration and Brewing Efficiency

### CBS-61H

Electrical Code	Heater Configuration	Voltage Connection	Phase	Wires	KW	Maximum Amp draw	Batches per Hour	
							Cold Water	Hot Water
C61016	2 X 3000 watt	120/208	single	3 + ground	4.6	22.1	3.7	8.6
		120/220	single.	3 + ground	5.2	23.4	4.3	9.0
		120/240	single.	3 + ground	6.1	25.5	5.0	9.0
C61026	2 X 4000 watt	120/208	single.	3 + ground	6.1	29.3	5.0	9.0
		120/220	single.	3 + ground	6.8	31.0	5.8	9.0
		120/240	single.	3 + ground	8.1	33.8	6.6	9.0
C61036	3 X 3000 watt	120/208	three.	4 + ground	6.9	19.5	5.6	9.0
		120/220	three.	4 + ground	7.7	20.6	6.5	9.0
		120/240	three.	4 + ground	9.1	22.4	7.4	9.0
C61046	3 X 4000 watt	120/208	three.	4 + ground	9.1	25.8	7.4	9.0
		120/220	three.	4 + ground	10.3	27.3	8.6	9.0
		120/240	three.	4 + ground	12.1	29.7	9.0	9.0
C61146	3 X 4000 W	480	three.	3 + ground	12.1	22.5	9.0	9.0

### Steam Heated Version

Electrical Code	Maximum Steam Demand	Steam Pressure	Volts	Wires	Maximum Amp draw	Maximum Batches/Hour
C61986	40 lbs./hr.	10-15 PSI	120	2+ground	0.8	9.0

### CBS-62H

Electrical Code	Heater Configuration	Voltage Connection	Phase	Wires	KW	Maximum Amp draw	Batches per Hour	
							Cold Water	Hot Water
C62016	3 X 3000 watt	120/208	single.	3 + ground	6.9	33.3	5.6	12.9
		120/220	single.	3 + ground	7.7	35.2	6.5	14.9
		120/240	single.	3 + ground	9.1	38.3	7.4	17.2
C62026	3 X 4000 watt	120/208	single.	3 + ground	9.1	44.1	7.4	17.2
		120/220	single.	3 + ground	10.3	46.6	8.6	18.0
		120/240	single.	3 + ground	12.1	50.8	9.9	18.0
C62036	3 X 3000 watt	120/208	three.	4 + ground	6.9	19.5	5.6	12.9
		120/220	three.	4 + ground	7.7	20.6	6.5	14.9
		120/240	three.	4 + ground	9.1	22.4	7.4	17.2
C62046	3 X 4000 watt	120/208	three.	4 + ground	9.1	25.8	7.4	17.2
		120/220	three.	4 + ground	10.3	27.3	8.6	18.0
		120/240	three.	4 + ground	12.1	29.7	9.9	18.0
C62056	6 X 3000 watt	120/208	three.	4 + ground	13.6	38.3	11.2	18.0
		120/220	three.	4 + ground	15.3	40.5	12.9	18.0
		120/240	three.	4 + ground	18.1	44.1	14.9	18.0
C62066	6 X 4000 watt	120/208	three.	4 + ground	18.1	50.8	14.9	18.0
		120/220	three.	4 + ground	20.4	53.7	17.3	18.0
		120/240	three.	4 + ground	24.1	58.5	18.0	18.0
C62146	6 X 3000 W	480	three.	3 + ground	18.1	22.5	14.9	18.0
C62166	6 X 4000 W	480	three.	3 + ground	24.1	29.7	18.0	18.0

### Steam Heated Version

Electrical Code	Maximum Steam Demand	Steam Pressure	Volts	Wires	Maximum Amp draw	Maximum Batches/Hour
C62986	80 lbs./hr.	10-15 PSI	120	2+ground	0.8	18.0

# Dimensions & Utility Connections

## CBS-61H

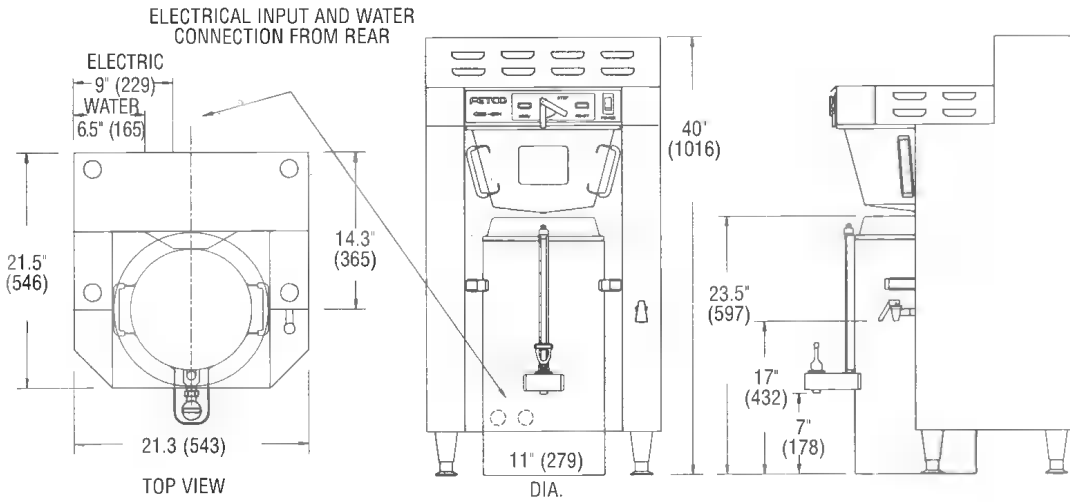

## CBS-62H

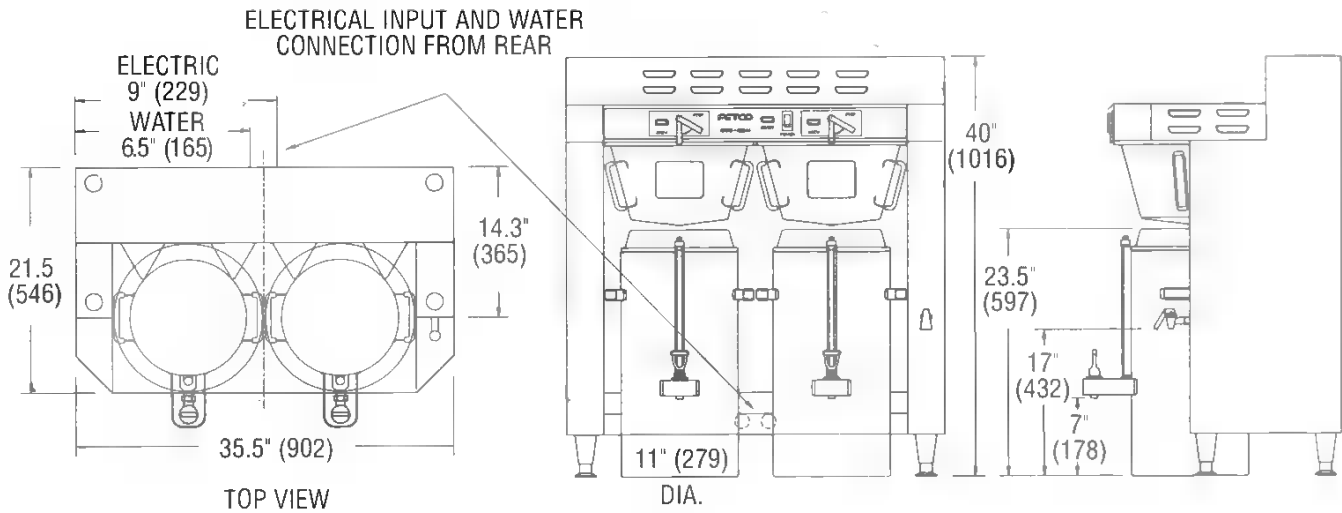

# Installation

(For Qualified Service Technicians Only)

## Keys To A Successful Installation

If not installed correctly by qualified personnel, the brewer may not operate properly and damage may result. Damages resulting from improper installation are not covered by the warranty.

Here are the key points to consider before installation:

### Electrical:

- ❖ All FETCO brewers require **NEUTRAL**. Ground is not an acceptable substitute. Installation without neutral may cause damage to the electronic components.
- ❖ The power connection to L2 on the terminal block must be at least 105 volts. Less than 105 volts will cause erratic behavior from the brewer.
- ❖ The power switch has a built-in circuit breaker. To reset it, turn to the “off” position, and then back to the “on” position.
- ❖ The electrical drawing for the brewer is located on the inside of the lower cover.

### Plumbing:

- ❖ This equipment is to be installed to comply with the applicable federal, state, or local plumbing codes.
- ❖ The water line must be flushed thoroughly prior to connecting it to the brewer to prevent debris from contaminating the machine.
- ❖ Verify that the water line will provide at least 1 gallon per minute for the CBS-61H, and 2 gallons per minute for the CBS-62H before connecting it to the brewer.

### General:

- ❖ Utilize only qualified beverage equipment service technicians for installation. A Service Company Directory may be found on our web site, <http://www.fetco.com>.

## Installation Instructions

### Brewer Setup

1. Review the Dimensions for the unit you are installing. Verify that the brewer will fit in the space intended for it, and that the counter or table will support the total weight of the brewer and dispensers when filled.
2. The brewer’s legs are shipped inside the brew baskets. Remove the brew basket(s) and the coffee dispenser(s). Place the brewer on its back and screw in the legs.
3. Place the brewer on the counter or stand.
4. When the brewer is in position, level it front to back as well as side to side by adjusting the legs.
5. Remove the lower cover to access the water and electrical connections. Knock-outs are provided in the back and base of the brewer body for the connections.



**Warning: Legs are to be adjusted for leveling the brewer only. Do not use for height adjustment or extend them higher than necessary.**

### Water Connection

1. Water inlet is a 3/8 inch male flare fitting.
2. The brewer can be connected to a cold or hot water line. Cold water is preferred for best coffee flavor, but hot water will allow for faster recovery times.
3. Install a water shut off valve near the brewer to facilitate service. If an in-line water filter is used, it should be installed after the water shut off valve and in a position to facilitate filter replacement.
4. Flush the water supply line and filter **before** connecting it to the brewer.
5. Verify that the water line will provide at least 1 gallons per minute for the CBS-61H, and 2 gallons per minute for the CBS-62H, and that the water pressure is between 20 and 75 psig.
6. Use a wrench on the factory fitting when connecting the incoming water line. This will reduce stress on the internal connections and reduce the possibility of leaks developing after the install has been completed.

## Electrical Connections

1. Verify that the actual voltage at the electrical service connection is compatible with the specifications on the brewer's serial number label. Make sure the electrical service includes **neutral**.
2. The temperature and water tank fill level are pre-set at the factory. There is no need to turn off the heaters during the installation process. The heaters are disabled by the control board until the tank is full of water. The heating process will start automatically when the tank has filled.
3. Only 120vac powered units are shipped from the factory with power cords and plugs attached. For other voltages, a terminal block is provided for connecting the incoming power wires. Consult local codes to determine if a cord and plug can be installed, or if the unit must be hard wired.
4. A fused disconnect switch or circuit breaker on the incoming power line must be conveniently located near the brewer, and its location and markings known to the operators.
5. The body of the brewer must be grounded to a suitable building ground. A ground lug is provided in the brewer next to the power terminal block. Use only 10 gauge copper wire for grounding.
6. Electrical connections must be secured in-place within the unit to meet national and local standards.

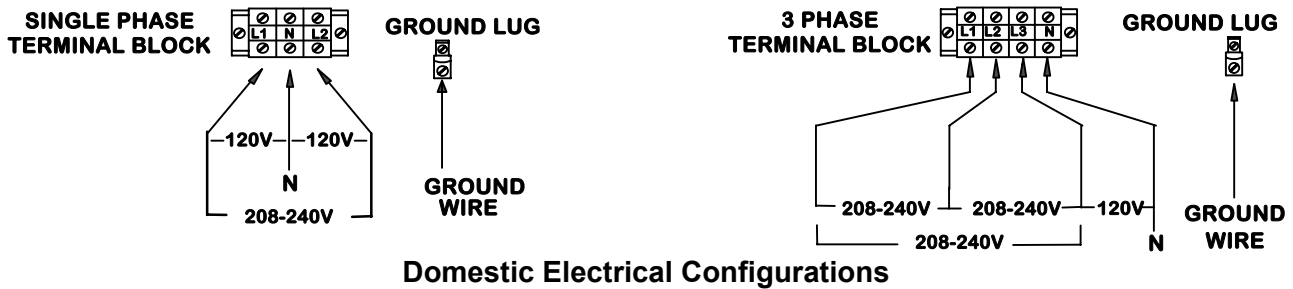
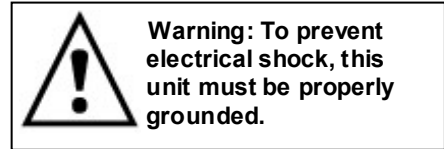

**Domestic Electrical Configurations**

7. Finally, connect the incoming power wires to the terminal block in accordance with applicable codes.

## Final Setup

1. Turn on the incoming water supply line and inspect both inside and outside of the brewer for leaks in all fittings and tubes
2. Turn on the incoming power.
3. Turn on the brewer's main power switch.
4. Within 6 seconds, the hot water tank will begin filling until the water is sensed by the probe at the top of the tank.
5. The heaters will be disabled by the control board until the tank is full.
6. The brewer will be ready for operation as soon as the ready light comes on to show that the water tank is up to temperature. The time required to reach brewing temperature will vary according to the electrical configuration ordered.
7. Review the Operating Instructions. Brew one full batch (water only) on each side to confirm proper fill levels. The brewer is factory set with water only (no coffee) to dispense the correct amount of water.
8. Re-attach the covers after one final inspection for leaks. Look closely in the top of the brewer at the dispense fittings during this inspection.

## Operating Training

Review the operating procedures with whoever will be using the brewer. Pay particular attention to the following areas:

1. Always pre-heat the dispensers before the first use of each day by filling them half way with hot water, and letting them stand for at least 15 minutes.
2. Don't remove the brew basket until it has stopped dripping.
3. Make sure the dispenser is empty before brewing into it.
4. Show how to attach covers, close, and or secure the thermal dispensers for transporting.
5. Show the location and operation of the water shut off valve as well as the circuit breaker for the brewer.
6. Steam from the tank will form condensation in the vent tubes. This condensation will drip into and then out of the brew baskets. 1/4 cup discharging overnight is possible. Place an appropriate container under each brew basket when not in use.
7. We recommend leaving the power to the brewer on overnight. The water tank is well insulated and will use very little electricity to keep the tank hot. Leaving the brewer in the on position will also avoid delays at the beginning of shifts for the brewer to reach operating temperature.

# Operating Procedures

## 1. Turn brewer on/off switch (E) to the on position

- The power switch will illuminate to indicate that the brewer has power and is operating.
- When the **ready light (F)** illuminates, the brewer is fully up to temperature. The amount of time required to gain full operating temperature will vary depending on the electrical configuration that was ordered, and the temperature of the incoming water.

## 2. Pre-heat the dispensers.

This step is very important to the overall success of the brewing operation. FETCO avoids the damaging affects of heat on fresh brewed coffee by using highly insulated dispensers. The dispenser must be preheated with hot water from the brewer. This preheating process ensures that the coffee in the first brew starts out hot. Significant heat loss will occur when brewing coffee into a cold dispenser. Preheating is not required for subsequent brews unless the dispenser remains empty for an extended period of time and has cooled down.

- Slide the empty brew basket(s) (D) into their rails and put the empty dispenser(s) in position under the basket for preheating. Select the half batch mode, (A) if you have this option.
- When the ready light illuminates, start a brew cycle by rotating the brew lever (B) to the brew position. This starts clean hot water flowing into the brew basket and then into the dispenser.
- Stop the cycle when each dispenser is approximately 1/2 full by moving the brew lever to the off position. This interrupts the brew cycle and resets the brewer .
- Let the dispensers stand 10-15 minutes, or until use, to allow the heat from the water to be absorbed by the dispensers.

## 3. Remove the brew baskets from the brewer when you are certain that the flow of hot water has stopped from the bottom of the basket.

- H model brewers will have a safety bar (C) in front of the brew basket to make removing the brew basket a 2-handed operation. This was done to help draw attention to the basket so any residual hot water or coffee will be noticed by the operator.
- Place a paper filter in each basket to be used. Pour into the paper filter the appropriate amount of pre-measured, ground coffee. The amount of coffee used will depend on your personal tastes and the recommendation of your roaster.
- Slide the brew basket back into the rails on the brewer. Insure the latch is outside of the basket.

## 4. Carefully drain any coffee or preheating water from the dispensers through the faucets before starting a coffee brewing cycle.

- Overflowing of the dispensers may result if the dispensers are not completely empty when the brew cycle begins. Verify by opening the faucet over an appropriate container or drain. The last several cups cannot be seen in the sight gauge tube.
- **CAUTION:** both the coffee or water may still be hot enough to cause burns, so be careful when draining the dispensers

## 5. Place the thermal dispenser(s) in position under the brew baskets.

- Ensure that the brew funnel is in place, the dispenser is empty, the faucet is closed, and the vent cap on the sight gauge is open.
- The twist lock cover is for transporting the dispenser only. It must be removed before placing the dispenser under the brew basket.

## 6. Start the brew cycle in the same manner used to start the water used to preheat the dispensers.

- It will not be necessary to interrupt the cycle while brewing coffee. The brewer will return to the stopped and ready status automatically.
- It is normal for the ready light to go out after the start of the brew cycle. On twin brewers, there is enough hot water in the brewer to support a second brew, even if the ready light is off. After brewing on both sides, you must wait for the ready light to come back on.
- The electrical configuration and the electrical power connected to the brewer will determine how long before the ready light comes back on for the next brew.

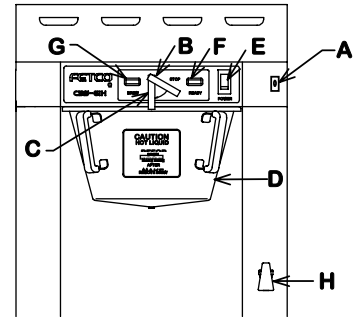

### Legend:

- A**-Full/half batch switch
- B**-Brew lever
- C**-Safety bar
- D**-Brew basket
- E**-On/off switch
- F**-Ready light
- G**- Brew light
- H**- Hot water faucet

## CAUTION

- Do not remove the brew basket immediately after the brew cycle has finished. Wait until dripping from the bottom of the brew basket has stopped. Carefully remove the brew basket while inspecting the inside of the basket for hot coffee that may have been trapped or has not finished draining.

## TPD- 3.0 LUXUS Dispensers:

The LUXUS dispensers are super insulated. They will hold a 195 degree beverage hot for extended periods of time. A full LUXUS will typically lose only 4 degrees per hour if the dispenser is preheated first with hot water.

Closing a LUXUS dispenser for transportation or storage must be done in the following steps to avoid spraying beverages from the top of the sight gauge. Failure to follow these steps in order can cause a hydraulic reaction. By moving the funnel vent cap down on the larger surface area of the main body an upward movement amplified many times is created in the sight gauge. This forces the fluid out the top of the sight gauge vent.

1. Install the twist lock cover, ensuring that the safety lock engages.
2. Close the sight gauge vent plug.
3. Close the twist lock cover funnel vent cap.
4. Open the LUXUS by reversing the above order. Open the funnel vent cap first, then the sight gauge vent cap.

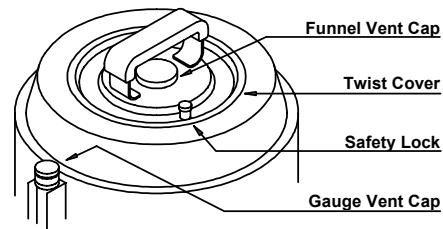

Because the faucet body is metal, it will dissipate the beverage temperature over time. This temperature loss is more noticeable with hot beverages than cold. If a dispenser of hot coffee goes unused, the first ounce or two will be cool and should be discarded. Subsequent cups will be hot.

## Cleaning:

Use the same techniques and products as you would use to clean any coffee urn i.e.

- a) the sight gauge brush to scrub the gauge
- b) urn brush for inside the dispenser
- c) urn cleaner to clean the dispenser
- d) stainless steel polish for the outside
- e) hot water and towels for the faucet parts

---

# Service

## Warranty

All FETCO brewers come with a limited warranty. All warranty service must be pre-authorized by calling the FETCO Service Department at (800) 338-2699.

## Principles of Operation

### Fill System

The fill system consists of a liquid level control board, a water level probe at the top of the tank, a fill valve, and a fill tube. As the water rises and touches the probe, continuity is established between the probe tip and the tank body, and the fill valve closes.

When water is dispensed, the water level drops below the probe. After a 5 second delay, the fill valve opens until the water touches the probe again.

The 5 second delay, and the speed that water refills the tank during brewing, results in many short bursts of water. The sound made by these repetitive bursts will let you know the fill system is functioning normally.

The fill system is designed to protect the heaters during both the installation and a loss of the water supply. During initial installation, or whenever the power switch is turned on, voltage will not be supplied to the thermostat until the tank fills and water touches the water level probe. During operation, when water is dispensed and the water level drops below the probe, a fill signal is sent to the fill valve. If no water is sensed by the probe after 40 seconds, the voltage to the thermostat and the heaters is removed.

Water enters the tank through the fill tube. A hole is drilled in the upper portion of the fill tube to prevent water from being siphoned from the tank. The fill tube extends to the bottom area of the tank. This introduces cold incoming water directly to the heaters and away from the dispense assembly.

The water tank can be drained through a valve located inside the lower compartment of the brewer.

### **Temperature System:**

The temperature system consists of an electronic thermostat, a temperature probe, and heating elements, and is enabled by the liquid level control board. (See the previous section - Fill Circuit.)

When the water level probe is in contact with water, power is delivered to the thermostat through the liquid level control board. If the temperature probe senses that the water is not hot enough, the thermostat energizes the heating elements through the mercury relay, the water is heated, and the ready light goes off.

Once the water temperature reaches the set point, the thermostat disengages power to the heaters and the ready light illuminates.

The thermostat is adjusted to 205° F ± 2° at the factory. (Slightly lower for high altitude installations.)

### **Timing System:**

The timing system consist of the timer and the dispense latch assembly.

When the brew handle is rotated from the stop to the brew position, it pushes the plunger in the latch coil and closes the micro switch, and the timer starts the timed cycle. It also starts the hot water flowing.

The timer energizes the dispense latch coil, which acts as a magnet, to hold the brew handle in the brew position. It also lights the brew light. The coil remains energized throughout the brew cycle timed sequence.

When the timer finishes its cycle, it removes voltage from the latch coil. The latch coil then releases the brew handle, a spring returns it to the stop position, and the flow of water stops. This return opens the micro switch, stopping voltage from going to the timer. The brew light and the timer are disabled, and wait for the brew handle to engage the next brew cycle.

The timer used with the 1/2 batch option has a small jumper wire on one end. A switch can replace this jumper to open or close this connection. Opening this connection cuts the timed output in half.

### **Dispense System:**

The dispense system is completely mechanical. It is one of the areas that makes FETCO's brewer truly unique. (See the illustration in this section.)

When you rotate the brew lever down to brew, the end of the dispense tube is submerged in the hot water tank. It is held in the brew position by the magnetic action of the dispense latch coil.

The brew water travels down the dispense tube to the sprayhead assembly. The rate of flow over the coffee is controlled by the flow disc above the spray cutter. The standard hole in the flow disc is .281". Other flow discs are available for special situations like high levels of by-pass.

The sprayhead can be assembled incorrectly during cleaning. Refer to the cleaning label on the brewer for proper assembly. The flow disc has the flange down, flat side up. The six triangle spray cutter has the flange up. The eight hole spray cutter used in place of the triangle cutter goes bumps down.

A bypass valve and tube are connected to the sprayhead. This valve directs brew water around the outside edge of the filter paper. The by-pass valve is shipped in the closed position from the factory. Each time the valve is adjusted, the brew volume is affected. Adjustment of the by-pass valve is for flavor only. When the timer circuit releases the brew latch, the dispense tube pops back above the hot water level. The remaining brew water drains from the dispense system leaving it free of standing water. Steam escaping from the brew tank through this tube inhibits the formation of lime in the brew system.

The dispense system is clean & semi dry for all but the brief time required for the brew cycle. This eliminates any chance of lime build-up affecting the brew cycle.

It is very easy to dislodge the dispense tube seals while servicing the dispense system. If you see it leaking profusely, remove the nut and dispense tube. Reset the seal fully into the recess and carefully insert the dispense tube. Then secure the locknut before you back the tube into position. (See detailed instructions on page 10.

## Mechanical Illustration - Dispense System

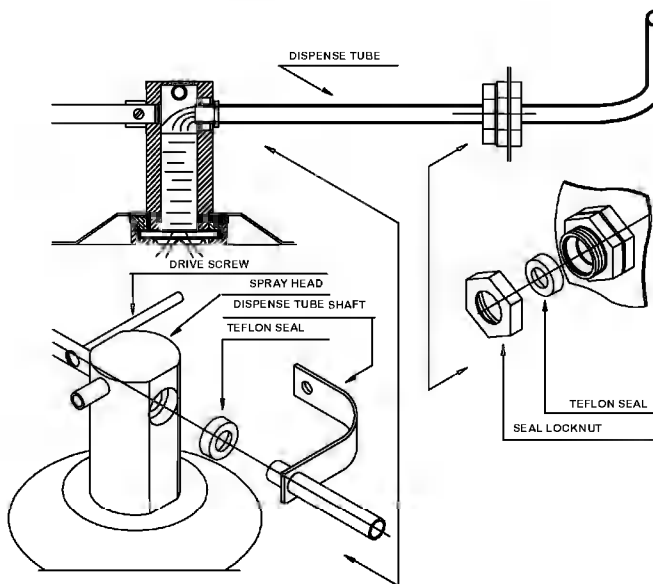
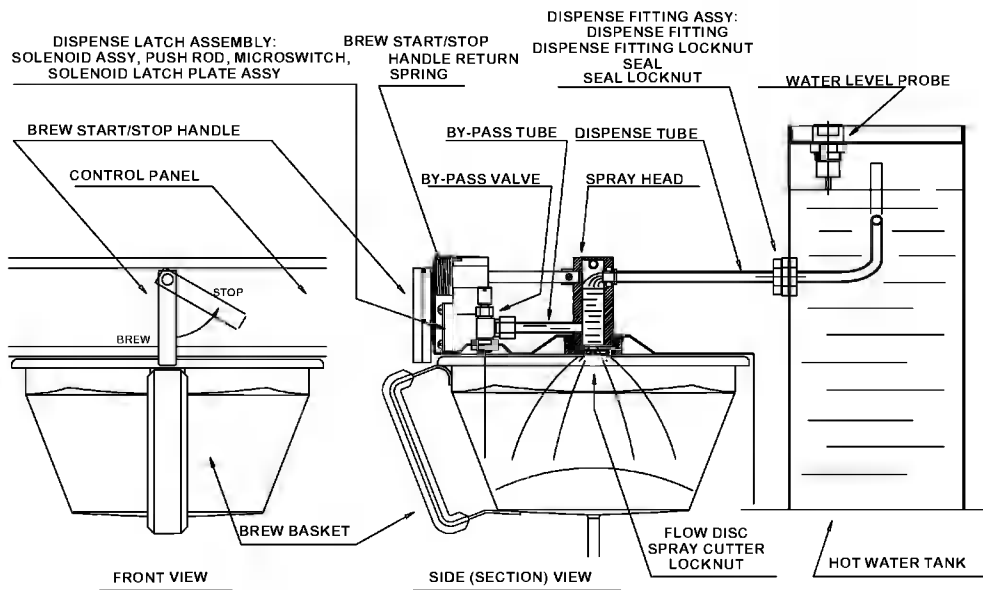

### To remove the dispense tube:

1. Unscrew seal locknut and release the drive screw from dispense tube shaft.
2. Turn the dispense tube slightly back and forth, while pushing the tube into the hot water tank until it is free from the sprayhead.
3. Pull the dispense tube out of the tank. Remember the tube is bent inside the tank. The seal will come out with the tube.

### To install the dispense tube:

1. Clean any lime build up off the tube and then slide the seal off. Push the seal carefully into its chamber in the fitting. (spring towards the hot water tank.)
2. Place the seal locknut onto the tube and slide the tube into the seal. Tighten the seal locknut.
3. Work the tube back into the sprayhead seal.
4. Join the dispense tube shaft and the brew handle shaft with the drive screw.

## Adjustments

### Thermostat Adjustment:

#### **For equipment manufactured before April 1, 2004**

The brewer's water tank temperature is factory set at 205°F (slightly lower for high altitudes, to prevent boiling). This setting will deliver water at 195°F ± 5° to the coffee grounds.

Measure the temperature by holding a thermometer in the stream of water flowing out of the hot water faucet. The temperature should be 195°F ± 5°.

If an adjustment is necessary:

- Remove the upper cover of the unit.
- The thermostat is located in the upper section of the brewer. Locate the adjustment stem, which may be taped to the thermostat.
- Insert the stem into the adjustment hole.
- Turn the adjustment stem slightly clockwise (as viewed from the stem insertion point) to increase the temperature, and counter-clockwise to decrease the temperature.
- If you decreased the temperature setting, run 2 or 3 brew cycles to allow enough cold water into the brewer to lower the tank temperature.
- Wait for the "ready" light to come on, and measure the temperature again.
- Repeat until the desired temperature is obtained.
- Replace the cover(s).

#### **Effective April 1, 2004:**

A new digital thermostat and temperature probe were introduced as a direct replacement for the old style thermostat and probe.

During normal operation, the digital readout displays the last two digits of the actual water temperature. When the adjustment tool is turned, the readout begins flashing to indicate the set point, not the actual temperature. After the tool is released, the readout stops flashing and displays the actual temperature again.

A red LED lights when the power to the thermostat is on. A yellow LED lights when the thermostat is calling for heat.

To adjust, turn the adjustment tool. If no adjustment tool is present, a small flat-head screwdriver may be used. The display will flash, indicating that the display is showing the set point, not the actual temperature.

The default temperature scale is Fahrenheit. When set to Fahrenheit, the display shows only the last 2 digits of the temperature.

Examples:

 = 75°F

 = 187°F

 = 203°F

The dots below the numbers indicate the temp range.

0 dots – less than 100° F

1 dot – between 100° and 200° F

2 dots – over 200° F

## Timer Adjustment:

### For equipment manufactured before April 1, 2004

The timers control the amount of water that is used for brewing. The dual sided brewer, model # CBS-62H, has separate timers to control each side independently.

All timers are factory set to deliver the correct amount of water.

There are three possible types of timers used:

- Part # 51006 – full batch only (standard)
- Part # 51005 – full / half batch (optional) The half batch setting provides exactly half the amount of water as the full batch setting.
- Part # 51017 – dual portion (optional) The timer has 2 independent settings.

Adjustment of the factory settings may be desired to compensate for the amount of water absorbed by the coffee grounds. Approximately 2 ounces of water will be absorbed for every ounce of coffee.

To adjust the timer:

- Remove the brewer's upper cover.
- If your brewer has the half-batch or dual portion option, make sure the selector switch is in the full batch position.
- Note the current setting of the dial before making any adjustments.
- Turn the knob clockwise to increase and counter-clockwise to decrease the timer setting. On the dual portion timer, the knob labeled "T1" controls the full batch setting.
- Run a full brew cycle to check the brew level.
- If necessary, repeat the adjustment until the desired volume is obtained.
- For the dual portion timer, set the selector switch on "half" and adjust the knob labeled "T2" until the desired volume of water is obtained.
- Replace the cover.

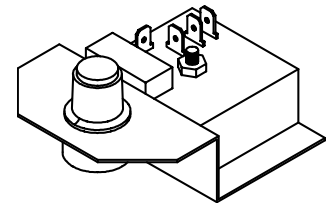

# 51006 timer, 120V

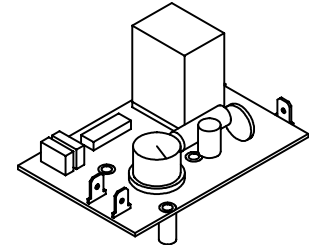

#51005  
timer, full/half, 120V

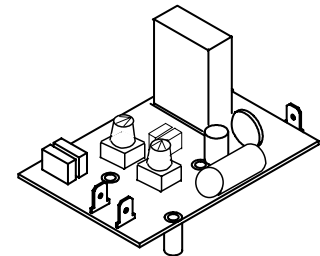

#51017  
timer, dual portion, 120V

### Effective April 1, 2004:

A new digital timer was introduced as a direct replacement for the three old style timers. When a batch selector switch is not connected, the timer functions as a single portion timer.

The timer has two independent settings, with three dials for each setting. The first dial in each group sets 100 second increments, the second dial sets 10 second increments, and the third dial sets 1 second increments.

A red LED lights when the power to the timer is on. A yellow LED lights when the timer is running.

A small flat head screwdriver is required to adjust the dials.

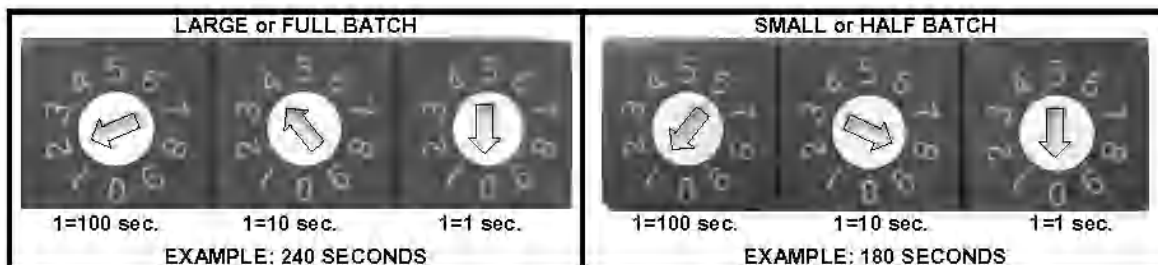

part # K034, digital timer, 100-120 VAC  
part # K036, digital timer, 200-240 VAC (export versions only)

## Water Level Control Board

### Effective April 1, 2004:

A new digital water level control board was introduced as a direct replacement for the old style liquid level control board. The new board features a jumper to adjust its' sensitivity to reverse osmosis or other types of ultra-pure water.

The default jumper setting is LO for normal water. If the brewer tank overfills because of ultra-pure water, the jumper should be set to HI.

A red LED lights when the power to the board is on.

A green LED lights when the water level probe detects that the tank is full.

A yellow LED lights when the FILL circuit is energized.

A second yellow LED lights when the HEAT circuit is energized.

### **Bypass Adjustment:**

The purpose of the bypass valve is to allow a portion of the brewing water to flow between the brew basket and the wire insert, directly into the server, without coming in contact with the coffee grounds. The bypass can be adjusted from 0% to 33% of the total brewing water. Dual brewers (CBS-62H), have separate bypass valves on each side. Unless requested at the time of order, all brewers are shipped with the bypass valves closed (0%). Adjusting the bypass always changes the total brew volume, so the timer setting must always be checked and adjusted.

To adjust the bypass:

- Remove the brewer's upper cover.
- The bypass valve is located above the brew basket, to the right and to the front, as you are facing it.
- Remove the brew basket.
- Place a container under the spray head and a separate container under the bypass hole.
- Turn the bypass valve clockwise to decrease, and counter-clockwise to increase the bypass amount. A good starting point would be one full turn for each 5% change.
- Brew a full cycle and measure the amount of water in both containers.
- The ratio of the bypass water to the total in both containers is the bypass percentage.  
Example: ½ gal. bypass + 2.5 gal. from spray head = 3 gal. total. Bypass = 33.3%.
- Several adjustments may be necessary until the desired results are achieved.

# Dispenser Parts

## LUXUS TPD- 3.0

Reference Number	Part Number	Description
1	71026	faucet, complete, black handle (ES)
1	71037	faucet upper assy. w/black handle (handle, spring, seat cup and nut)
1	71035	faucet seat cup
1	71028	faucet handle- black
1	71027	faucet handle, decaf faucet (orange)
2	31045	faucet union nut
3	71036	faucet "c" ring
4	102052	faucet shank assembly
5	24009	faucet shank "o" ring 1/2" x 3/4"
6	12018	vent top plug
7	71017	sight gauge washer lower
8	71024	sight gauge cap
9	71018	sight gauge washer upper
6-9	102020	sight gauge cap and vent assy.
10	21035	sight gauge tube 12-1/2" (plastic)
10	71033	sight gauge tube 12-1/2" (glass)
11	82015	faucet shank screw-2 required
12	101038	twist lock cover assembly
13	101051	brew funnel assembly
15	41011	LUXUS label

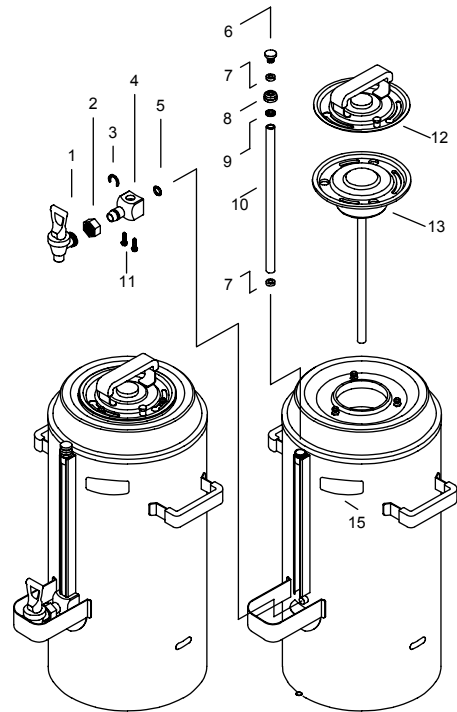

For current parts pricing, visit [www.fetco.com](http://www.fetco.com).

## Brewer Parts

<b>CBS 61H &amp; 62H Parts List</b>				
<b>Part #</b>	<b>Description</b>	<b>Item#</b>	<b>Used On</b>	
25004	Thermostat Temp probe Lead Cover (tubing)	0	61	62
82019	Heater Screw, 10-32 x 1/4" ss (heater connection)	0	61	62
83004	Heater Gasket 3/4" o.d. (also used behind faucet on 30's)	0	61	62
83006	Heater Washer, 1"o.d. x 1/2" l.d.	0	61	62
84004	Heater Locknut, 1/2-20	0	61	62
53031	Thermostat 220vac solid state (export)	0	61	62
71003	Faucet Seat cup, HOT water faucet	0	61	62
71035	Faucet Seat cup, on all std. faucets incl. 60's hot water	1	61	62
71037	Faucet upper assy. w/black handle	1	61	62
71027	Faucet Handle, Decaf faucet (orange)	1	61	62
71026	Faucet, complete w/blk handle (ES model)	1	61	62
31045	Faucet Union Nut (1.5 & 3 gal. Luxus & 1.5 gal. cont.)	2	61	62
71036	Faucet C ring , for retaining faucet union nut	3	61	62
102052	Faucet Shank assy. (1.5 & 3 gallon LUXUS )	4	61	62
24009	Faucet Shank O Ring 1/2 x 3/4 1.5 & 3 Gal. Luxus	5	61	62
12018	Vent Top Plug	6	61	62
71017	Sight glass washer LOWER (1.5 & 3 gal. luxus & 1.5 cont)	7	61	62
71024	Sight glass cap (1.5 & 3 gal. luxus & 1.5 cont.)	8	61	62
71018	Sight glass washer UPPER (1.5 & 3 gal. luxus & 1.5 cont.)	9	61	62
21035	Sight Glass Tube 12 1/2" (3 gal. luxus)	10	61	62
82015	Faucet Shank Screw 2 needed per (1.5 & 3 gal. Luxus)	11	61	62
101038	Twist lock cover assy. (1.5 & 3gal. luxus)	12	61	62
101051	Brew Funnel assy. 3 gal. Luxus	13	61	62
97013	Tube, silicone 1/4 x 3/8"	16	61	62
31005	Tank Fitting (tank vent)	17	61	62
31006	Locknut 1/8" NPT (1 on vent & 2 on bypass valve)	18	61	62
31006	By-pass & misc. Locknut 1/8" NPT	18	61	62
31009	Locknut 3/8" NPSL (2 ea. for dispense & water inlet)	21	61	62
31037	Thermostat Temp probe Locknut 1/4" NSPL (temp. probe tank fitting)	22	61	62
31036	Thermostat Temp probe tank Fitting 1/4" MPT x 1/4" comp.	23	61	62
53015	thermostat temp probe 14" (use with K033 digital thermostat or 53012 thermostat)	24	61	62
102198	Digital temp probe assy., 14" (use with K033 digital thermostat only)	24	61	62
102013	Tank Cover assy.	25	61	62
24002	Tank Cover Gasket	26	61	62
107003	Heater element 4000w 240v	27	61	62
107002	Heater element 3000w 240v	27	61	62
002010	Water Level Probe Weldment	28	61	62
21026	Water Level Probe Housing	29	61	62
31081	Plug 1/4" MPT hex head	30	61	62
002043	Tank Fill Tube Weldment	32	61	62
31021	Tank drain Fitting 3/4 x 16 x 1/4" FPST HEX	33	61	62
31055	Fill Valve Fitting 3/8" MPT x 3/8" comp. elbow (inlet opt)	36	61	62
33011	Tank drain Fitting Locknut 3/4 x 16	39	61	62
31011	Locknut 3/4 x 16 (tank drain, inlet tube)	39	61	62
31082	Nipple 1/4" MPT x 3/8" MPT	40	61	62
34004	Valve ball 3/8" x 3/8" FPT	41	61	62
31073	Tank Fitting 3/8" MPT x 3/8" hose barb (hot water tank out)	42	61	62
25002	Tank vent tube, Silicone Tubing 1/4 x 7/16 x 7 3/4"	43	61	62
33006	Tank Fitting (dispense tube 7/16" )	44	61	62
33007	Tank Locknut (for tank dispense tube fitting 7/16")	45	61	62
31052	Dispense Tube seal LOCKNUT 7/16"	47	61	62
004006	Tank Weldment	48	61	
004012	Tank Weldment	48		62
01178	Brewer Upper Cover	49		62
01111	Brewer Upper Cover	49	61	
41011	LUXUS label	50	61	62
002011	Dispense Tube Weldment 7/16 dia.	51	61	62
24008	Dispense Tube Seal 7/16"	52	61	62
31083	Spray Head (Large brass part & is NOT the spray cutter)	53	61	62
31070	Fitting (by pass & tank drain outlet)	54	61	62
102028	By-pass Valve assy.	56	61	62
83005	By-pass & misc. Washer	57	61	62
85005	Brew handle latch plate Retaining clip	58	61	62
85004	Brew handle Return Spring	59	61	62

14002	Brew handle Latch Plate	60	61	62
002005	Brew handle Latch Weldment	61	61	62
33002	Spray Head Lock Nut	62	61	62
05016	Spray cutter flow disk, .281" hole	63	61	62
05014	Spray Cutter ( 8 + 1 )	64	61	62
31015	Spray Cutter Locknut	65	61	62
58026	Lamp, "brew"	71	61	62
58004	Lamp, "brew" indicator, amber	71	61	62
102012	Brew Handle brew start/stop assy.	72	61	62
13005	Brew handle Safety Handle	72	61	62
82004	Brew handle Screw, 6-32 x 5/8" ss r.h.	72	61	62
82018	Brew handle Screw, 8-32 x 2" ss r.h.	72	61	62
86001	Brew handle Bushing	73	61	62
58027	Lamp, "ready"	74	61	62
58006	Lamp, "ready" indicator, green	74	61	62
52076	Switch, power w/circuit breaker, 220VAC (EXPORT)	75	61	62
52077	Switch, power w/ circuit breaker, 120VAC	75	61	62
45028	Nameplate	76		62
31001	Fitting (fill valve inlet)	77	61	62
57004	Fill Valve Coil, 120vac (S-45)	78	61	62
57021	Fill Valve Coil, 230vac (S-45 export)	78	61	62
57003	Fill Valve, repair kit (S-45)	78	61	62
57001	Fill Valve assy., 120v, brass body w/bracket (S-45)	78	61	62
57022	Fill Valve assy., brass body, 220vac (S-45 export)	78	61	62
31055	Fill Valve Fitting 3/8" MPT x 3/8" comp. elbow (inlet opt)	79	61	62
52018	Relay mercury 35amp DP 120vac (208-240v 1ph brw.)	80	61	62
52025	Relay mercury 60amp TP 120vac (208-240v 3ph brw)	80	61	62
52030	Relay mercury 35amp DP (export 208-240v coil)	80	61	62
52033	Relay mercury 30amp TP 120vac (208-240v 3ph brw.)	80	61	62
52034	Relay mercury 30amp TP (export 208-240v coil )	80	61	62
52035	Relay mercury 60amp DP 120vac (208-240v 1ph brw.)	80	61	62
52038	Relay mercury 60amp TP 200vac (208-240v 3ph brw.)	80	61	62
52003	Ground lug terminal MEDIUM size	81	61	62
102042	Terminal block assy. 4 pole	82	61	62
102041	Terminal block assy. 3 pole	82	61	62
71044	Faucet, lower hot water on 60's	83	61	62
101050	Brew basket assy. regular	85	61	62
002014	Brew Cone Weldment	86	61	62
09009	Brew basket Wire insert 18 x 7-1/2"	87	61	62
09005	Brew Basket Wire insert 21 x 7	87	61	62
K033	Digital thermostat, 100-120VAC	89	61	62
K035	Digital thermostat, 200-240VAC (EXPORT)	89	61	62
K034	Digital Timer Kit, 100-120VAC	90	61	62
K036	Digital Timer Kit, 200-240VAC (EXPORT)	90	61	62
102008	Dispense Latch, Solenoid assy. 120vac	92	61	62
102039	Dispense Latch, Solenoid assy. 220vac (export)	92	61	62
108034	Liquid Level Control Brd. 100-120VAC, 50-100K ohm	93	61	62
108035	Liquid Level Control Brd. 200-240VAC, 50-100K ohm (EXPORT)	93	61	62
58024	Switch, full/half batch selector, w/harness (optional)	94	61	62

For current parts pricing, visit [www.fetco.com](http://www.fetco.com).

# Parts Drawing: CBS 61H & 62H

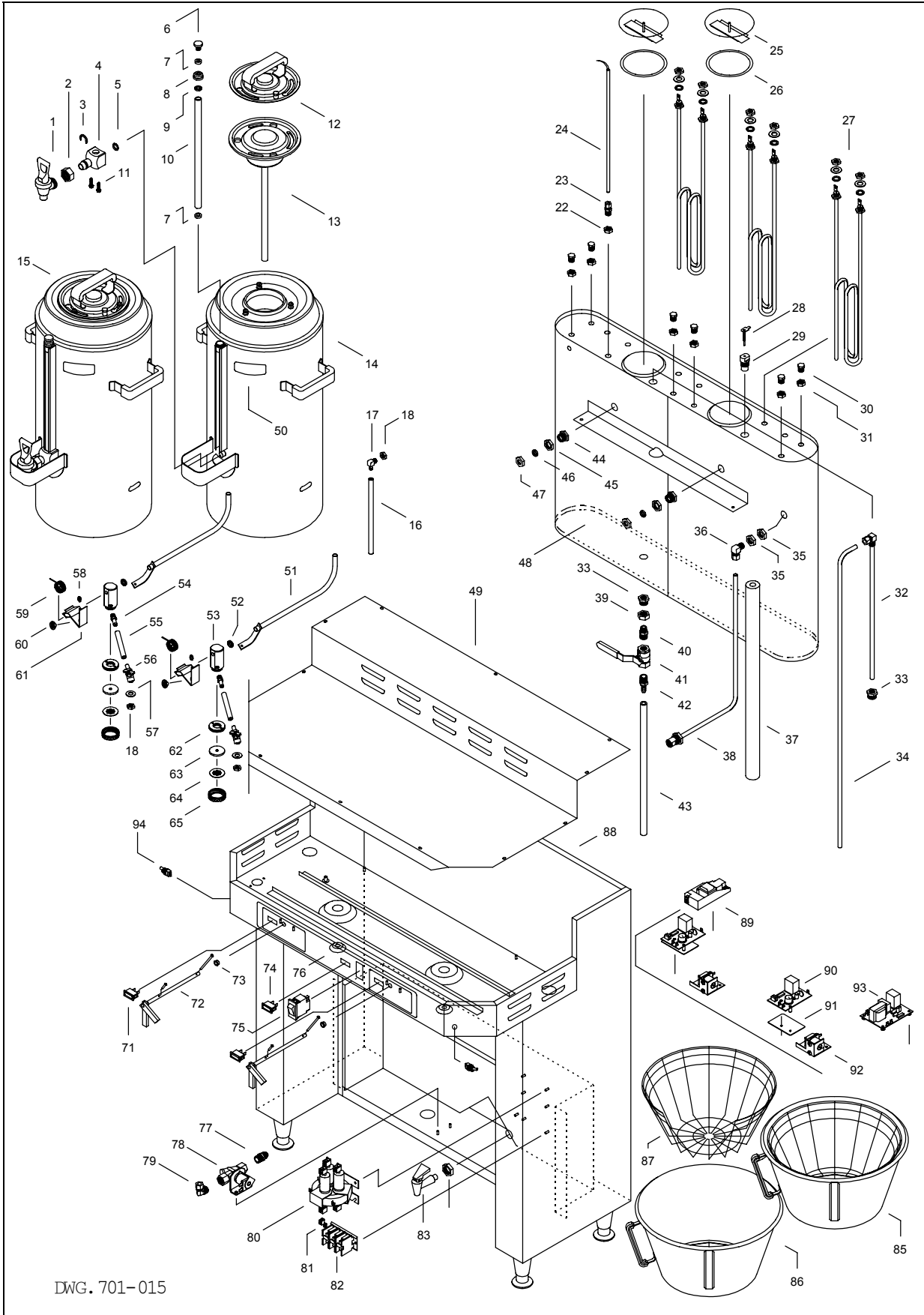

DWG. 701-015

# Troubleshooting

Brewing Problem	Possible Cause	Solution
<b>Brew handle</b> will not stay down	Power switch off.	-Turn switch on.
	No power to the brewer (Brewer lights are not illuminated)	-Make sure the brewer is plugged in. -Check the wall circuit breaker / reset -Turn the brewer power switch off then back on (it has an internal breaker)
	Bad timer or dispense latch assembly. (Brew light <b>does not</b> come on and handle won't stay down)	-Check for voltage reaching the timer from the dispense latch assembly if yes replace timer. If no, replace latch assy.
	Bad dispense latch assy. (Brew light <b>does</b> come on and handle won't stay down)	-Replace the dispense latch assembly
	Bad dispense latch assembly (brewer buzzes when in brew cycle)	-Replace the dispense latch assembly
<b>Brew handle</b> stays down but no water is dispensed	No water reaching the brewer	-Make sure the shut off valve is open. -Check water line for kinks; replace line if necessary -Check to see if filter is clogged by changing it.
<b>Short brew levels EVERY BREW</b>  (One or Both sides are affected and levels are consistent)	Flow discs in spray heads in upside down	-Reassemble spray heads - bumps on spray cutter face ↓ with flange on flow disc facing ↓
	Water filter clogged	(See details in next section)
	Spray head clogged	-Clean and or replace the sprayhead
	Timer/s are set too low	-Advance timers to proper level.
	Incoming Voltage is too low for timers to function at proper time sequences	-Reset wall circuit breaker as one side may drop out & not flag the breaker. -Call an electrician to find loose connections in the building
<b>Short brew levels SOME BREWS</b>  (One or Both sides are affected and levels are erratic)	Water filter clogged. (problem is worse during simultaneous brews)	-Replace water filter
	Weak dispense latch assembly (usually buzzes during cycle)	-Replace dispense latch assembly.
	Water pressure or flow rate is too low or fluctuates too much to support a full brew. (problem is worse in simultaneous brews)	-Make sure brewer has a dedicated water line -Ensure that the shut off valve is open all the way (Never use needle saddle valves) -Increase the diameter of the water line to the brewer and or find stable source.
<b>Brew Time required to fill LUXUS are not the same for both sides</b>	Brewer is not level	-With an accurate level, level the brewer front to back and left to right by adjusting the feet.
<b>High brew levels EVERY BREW</b> (overfills but does stop) <b>SOME BREWS</b>	Timer/s are set too high	-Adjust timers down to appropriate level
	Thermal server not empty	-Empty the server and try again
<b>Brew basket or filter overflows</b>		-Call FETCO Service Dept. to discuss. (800) 338-2699
<b>Weak Coffee</b>	Spray head missing	-Attach spray head assembly.
	Improper dose	-Measure and confirm correct dose
	Filter papers	-Make sure only one paper is used
	Cracked dispense tube	-See "spray head drips MAJOR", below
	Low brew temperature (Temperature inside the hot water tank is set to 205° F, the metal delivery system drops the temp.)	-Adjust thermostat so the water stream measured at the bottom of the brew basket, 1/3 of the way through the brew cycle, equals 190 degrees + or - 5 degrees
<b>Grounds not saturated</b>	Spray head missing	-Replace spray head
	Half batch used incorrectly	-Use smaller "half batch" brew basket -Discourage half batch use -Investigate the need for a smaller brewer
	Water Softener in use	-Move brewer water feed to a non-softened source.
	Degassing - extremely fresh coffee	-Call FETCO Service Dept. to discuss. (800) 338-2699
<b>No bypass EVERY BREW →</b> <b>SOME BREWS →</b>	Bypass valve closed	-Open bypass valve
	Flow disc wrong size or missing	-Correct or replace flow disc
<b>Spray head / brew basket drips either side or both</b> MINOR	Condensation around the sprayhead area	-Wipe sprayhead area after brewing; place an empty container under brew cone when not in use.
	Condensation from water tank dripping through dispense tube	-Insert an empty brew basket and server under brew heads when not in use

<b>Brewing Problem</b>	<b>Possible Cause</b>	<b>Solution</b>
<b>Spray head / brew basket drips either side or both</b> MAJOR	Cracked dispense tube/s (This problem starts out minor but gets steadily worse)	-Replace both dispense tubes even if other side is not dripping
	Fill valve not sealing (Will drip even with power off.)	-See next section - "Brewer won't stop brewing", "Bad or stuck fill valve".
<b>Brewer won't stop brewing</b> (not same as high brew levels)	Dispense tube cracked	-See "sprayhead drips MAJOR" above
	Mechanical binding (brew handle stays down / brew light turns off at normal time)	-Re-align the brew handle / brass sprayhead tower / and dispense tube into a straight line by moving brass tower
	Water pressure over 75psi	-Place a water pressure regulator on the line and reduce to 20-75 psi
	Dispense tube drive screw off. A 2.5" screw that connects the handle to the dispense tube at the brass sprayhead tower. (handle returns up and brew lamp turns off but brewing continues)	-Ensure that the drive screw is straight (can be straightened by hand while still in the brew handle) and reconnect to the dispense tube. The flange that the drive screw engages MUST be held flat against the brass sprayhead tower, without being able to back out.
	Water level probe bad or encrusted with lime. (causes brewer to continue filling hot water tank which will overflow into the brew baskets)	-Clean lime build up on the probe tip and/or tank wall. (Holding the probe wire (green) from the probe end to the body of the brewer should stop the fill if the probe is bad but the liquid level board is good)
	Bad liquid level control board	-Replace the LLC board if grounding the probe end of the (green) probe wire to the body of brewer does not remove the voltage at the fill terminal on the LLC board.
	Bad or stuck fill valve	-Rebuild or replace the fill valve if no voltage is on the coil (it is not magnetic) and it still passes water to the tank. (Disconnect the outlet side to see if it leaks water to the tank)
<b>Coffee tastes too strong</b>	Incorrect dosage	-Measure and confirm the correct amount of coffee required
	Short brew levels	-See "Short brew levels", above.

<b>Temperature Problem (brewer only)</b>	<b>Possible Cause</b>	<b>Solution</b>
<b>See also LUXUS problems</b>		
<b>Brew water is cold / not hot enough, ready light is OFF.</b> (Before proceeding, make sure water tank refills when water is dispensed. The brewer will not heat unless the tank is full.)	No power to brewer.	-Make sure power switch is on. -Reset machine circuit breaker. -Check power connection. (plug or hard wire connection). -Check building circuit breaker. (Always reset breaker by switching off, then on.)
	Defective liquid level control board. (No power to thermostat).	-With power on, and water tank full, check LLC board for 120 volts on brown wire and neutral. Replace LLC board if there is no voltage.
	Bad connections on mercury relay. (No power to heaters).	-Check relay for burned or loose connections. Replace with high temperature connectors if necessary.
	Defective mercury relay. (No power to heaters).	-Check input and output voltages on relay. 120 volts on blue wire (input) but no voltage out to heaters indicates a bad relay.
	Bad heating element/s.	-Check amperage draw on heater wires. 0 amps = bad heater.
<b>Brew water is cold / not hot enough, ready light is ON.</b>	Bad Thermostat (the thermostat believes that it is at set temperature)	-Replace the thermostat and or thermal probe. It's not possible to trouble shoot the probe.
	Low brew temperature setting on thermostat	-See "Low brew temperature" under " <b>Weak Coffee</b> " section.
<b>Slow to recover temperature</b> (Ready light takes along time to come back on after brewing.)	Brewers with more than one heater can have just one fail	-Check amperage draw on heater wires. 0 amps = bad heater.
	Hot water tank limed up	-Remove access cover to the hot water tank and inspect for lime. Remove the brewer for shop de-liming if build up is thick.
<b>Boiling</b>	Thermostat set too high for altitude (Denver etc.)	-Reduce temperature setting to 3 degrees below boiling at your altitude
	Defective thermostat	-Replace the thermostat and or thermal probe. It's not possible to trouble shoot the probe.

<b>LUXUS TPD-1.5 Problem</b>	<b>Possible Cause</b>	<b>Solution</b>
<b>LUXUS leaking from the base</b>	Overflow of coffee, or water from cleaning running down the side and collecting in the black plastic base (1.5 gallon LUXUS only)	-Remove the plastic base (it slips on and off) wipe the interior and plastic base dry and reassemble. Monitor brew practices & do not clean containers in sinks or dishwashers
	Bad O-ring gasket behind faucet shank  (1.5 & 3 gallon LUXUS)	-Remove the faucet, then unbolt the faucet shank from the LUXUS and replace the O-ring.
<b>LUXUS leaking from sight gauge</b>	Brew level set too high	-Adjust timers for proper level
	Sight gauge cap not tight	-Tighten gauge cap (show operators how this could have been loosened when the vent cap was opened)
	Lower gasket missing or bad	-Replace and or discourage casual cleaning practices
<b>Coffee not hot enough</b>	LUXUS not preheated before first brew of the day	-Preheat the LUXUS 1/2 full with hot water and let stand for 15 minutes
	Attempting to hold coffee too long.	-Review discard times
	Using 1/2 batch on regular basis	-Encourage full batch use except at end of day or shift. Explore the need for smaller brewers
	Judging temperature from a sample that is too small, taken from an infrequently used LUXUS	-A small amount of coffee in the faucet body will cool in about 15 minutes.
<b>Drip from faucet</b>	Blockage in faucet (hair from cleaning brush, coffee oils, etc.)	-Remove faucet bonnet (top part with handle attached) and clean seat cup and faucet body. Clean on regular basis
	Faucet seat cup	-Remove faucet bonnet (top part with handle attached) and replace seat cup. Stained cups are OK cracked or brittle are not.
<b>Coffee won't dispense</b>	Vents closed on top of gauge tube and or twist lock cover	-Open vents (vents are closed only for transporting the servers or to extend holding times prior to serving coffee)







