

**Models: CBS-71A & AC Digital**  
**CBS-72A & AC Digital**  
**CBS-72AT & ATC Digital**



*Driven To Pioneer Innovation™*

**Table of Contents**

Contact Information .....	2	Operating Procedures .....	8
Description & Features .....	2	Brewing System .....	8
Specifications .....	2	Transfer System .....	9
Weights and Capacities .....	2	Programming .....	10
Electrical Configuration and Brewing Efficiency .	3	Cleaning & Maintenance .....	11
Installation .....	5	Parts .....	12

FETCO®, and LUXUS® are trademarks or trade names of Food Equipment Technologies Company.

## Contact Information

**FETCO®**  
 Food Equipment Technologies Company  
 600 Rose Road  
 Lake Zurich • IL • 60047-0429 • USA

**Phone:** (800) 338-2699 (US & Canada)  
 (847) 719-3000  
**Fax:** (847) 719-3001

**Internet:** www.fetco.com

**Email:** sales@fetco.com  
 techsupport@fetco.com

## Description & Features

**CBS-71A - Single Coffee Brewer**  
**CBS-71AC - Single Coffee Brewer**  
 with mobile dispensers  
**CBS-72A - Twin Coffee Brewer**

**CBS-72AC - Twin Coffee Brewer with mobile dispensers**  
**CBS-72AT - Twin Coffee Brewer with**  
 transfer system.  
**CBS-72ATC - Twin Coffee Brewer with transfer**  
 system and mobile dispensers.

- Thermal, portable, stainless steel dispensers, 6, 18, or 24 gallons.
- Tight fitting brew baskets seal in flavor and steam.
- Fully automatic, with electronic temperature control.
- Will not brew unless water temperature is correct.
- Thermal breakers and high pressure cutoff switch for safety.
- Mercury type power relay.
- Total serviceability from the front and top.
- 72AT/ATC versions: auto or manual transfer to 60 gallon tanks.

**Optional Features:**

- Power management
- Custom and export voltage

## Specifications

**Brew Volume:** 6 gallons (22.7 liters)  
*(Not adjustable)*

**Average Brew Time:** 7 minutes  
*(Allow an extra 3-5 minutes for coffee to finish dripping)*

**Water Requirements:** CBS-71: 1 ½ gpm, 20-75 psig  
 CBS-72: 3 gpm, 20-75 psig

**Coffee Filters:** 23" X 9" FETCO # F006

**Electrical:** See electrical configuration chart.

### Weights and Capacities

Brewer Model	Weight	Water Tank		Total Weight, filled
		Capacity	Weight	
CBS-71A	239 lbs.	18 gal.	150 lbs.	389 lbs.
CBS-72A/AT	420 lbs.	2 X 18 gal.	300 lbs.	720 lbs.

Dispenser	Weight (empty)	Capacity	Weight (full)
LBD-6	40 lbs.	6 gal.	90 lbs.
LBD-6C	152 lbs.	6 gal.	202 lbs.
LBD-18	228 lbs.	18 gal.	378 lbs.
LBD-24	222 lbs.	24 gal.	422 lbs.
LBD-60	227 lbs.	60 gal.	726 lbs.

# Electrical Configuration and Brewing Efficiency

## CBS-71A & AC

6.0 gallons per batch

Model	Heater Configuration	Voltage Connection	Phase	Wires	KW	Maximum Amp draw	Batches per Hour (max 5)	
							Cold Water	Hot Water
CBS-71A (-1)	3 X 5 KW	120/208	3 ph.	4 + ground	11.5	33.0	3.0	5.0
		120/220	3 ph.	4 + ground	13.3	36.0	3.3	5.0
		120/240	3 ph.	4 + ground	15.2	37.9	3.6	5.0
CBS-71A (-2)	3 X 10 KW	120/208	3 ph.	4 + ground	22.7	64.3	4.5	5.0
		120/220	3 ph.	4 + ground	26.3	70.3	4.8	5.0
		120/240	3 ph.	4 + ground	30.2	74.0	5.0	5.0
CBS-71A (-3)	3 X 10 KW	120/480	3 ph.	4 + ground	30.2	37.9	5.0	5.0

Batches per hour based on 7 minute brew time, with no bypass

A and AC versions are actually identical units. The only difference is the stand or counter upon which the unit is placed.

## CBS-72A & AC

6.0 gallons per batch

Model	Heater Configuration	Voltage Connection	Phase	Wires	KW	Maximum Amp draw	Batches per Hour (max10)	
							Cold Water	Hot Water
CBS-72A (-1) <i>with power management</i>	3 X 5 KW on each side	120/208	3 ph.	4 + ground	11.6	33.7	4.7	10.0
		120/220	3 ph.	4 + ground	13.4	36.7	5.4	10.0
		120/240	3 ph.	4 + ground	15.3	38.6	6.2	10.0
CBS-72A (-2) <i>without power management</i>	3 X 5 KW on each side	120/208	3 ph.	4 + ground	22.8	65.0	6.0	10.0
		120/220	3 ph.	4 + ground	26.4	71.0	6.6	10.0
		120/240	3 ph.	4 + ground	30.3	74.7	7.2	10.0
CBS-72A (-3) <i>with power management</i>	3 X 10 KW on each side	120/208	3 ph.	4 + ground	22.8	65.0	9.3	10.0
		120/220	3 ph.	4 + ground	26.4	71.0	10.0	10.0
		120/240	3 ph.	4 + ground	30.3	74.7	10.0	10.0
CBS-72A (-4) <i>with power management</i>	3 X 10 KW on each side	120/480	3 ph.	3 + ground	30.3	37.9	10.0	10.0
				(plus 120V cord & plug)				
CBS-72A (-5) <i>without power management</i>	3 X 10 KW on each side	120/480	3 ph.	3 + ground	60.3	74.7	10.0	10.0
				(plus 120V cord & plug)				

Batches per hour based on 7 minute brew time, with no bypass

Each CBS-72 is actually two separate brewers in one body. Each side has a separate water tank and 3 heaters. The power management feature allows only one side of the brewer to heat at any given time, which limits the total amperage required for operation.

A and AC versions are actually identical units. The only difference is the stand or counter upon which the unit is placed.

## CBS-72AT & ATC

6.0 gallons per batch

Model	Heater Configuration	Voltage Connection	Phase	Wires	KW	Maximum Amp draw	Batches per Hour (max10)	
							Cold Water	Hot Water
CBS-72AT (-1) <i>with power management</i>	3 X 5 KW on each side	120/208	3 ph.	4 + ground	11.9	35.7	4.7	10.0
		120/220	3 ph.	4 + ground	13.7	38.7	5.4	10.0
		120/240	3 ph.	4 + ground	15.6	40.6	6.2	10.0
CBS-72AT (-2) <i>without power management</i>	3 X 5 KW on each side	120/208	3 ph.	4 + ground	23.1	67.0	6.0	10.0
		120/220	3 ph.	4 + ground	26.7	73.0	6.6	10.0
		120/240	3 ph.	4 + ground	30.6	76.7	7.2	10.0
CBS-72AT (-3) <i>with power management</i>	3 X 10 KW on each side	120/208	3 ph.	4 + ground	23.1	67.0	9.3	10.0
		120/220	3 ph.	4 + ground	26.7	73.0	10.0	10.0
		120/240	3 ph.	4 + ground	30.6	76.7	10.0	10.0
CBS-72AT (-4) <i>with power management</i>	3 X 10 KW on each side	120/480	3 ph.	3 + ground (plus 120V cord & plug)	30.6	39.9	10.0	10.0
CBS-72AT (-5) <i>without power management</i>	3 X 10 KW on each side	120/480	3 ph.	3 + ground (plus 120V cord & plug)	60.6	76.7	10.0	10.0

Batches per hour based on 7 minute brew time, with no bypass

Each CBS-72 is actually two separate brewers in one body. Each side has a separate water tank and 3 heaters. The power management feature allows only one side of the brewer to heat at any given time, which limits the total amperage required for operation.

AT and ATC versions are actually identical units. The only difference is the stand or counter upon which the unit is placed.

## Steam Heated Brewers

Model	Maximum Steam Demand	Steam Pressure	Volts	Wires	Maximum Amp draw	Batch Size	Brew Heads	Maximum Batches/Hour
CBS-71A/AC (-4)	80 lbs./hr.	10-15 PSI	120	2 + ground	1.8	6.0 gal.	1	6
CBS-72A/AC (-6)	160 lbs./hr.	10-15 PSI	120	2 + ground	2.5	6.0 gal.	2	10
Customer supplies one ¼ inch steam line. No power management between sides.								
CBS-72A/AC (-7)	80 lbs./hr. per side	10-15 PSI	120	2 + ground	2.5	6.0 gal.	2	10
Customer supplies two ½ inch steam lines. No power management between sides.								
CBS-72A/AC (-8)	80 lbs./hr.	10-15 PSI	120	2 + ground	2.5	6.0 gal.	2	10
Customer supplies one ½ inch steam line. With power management between sides.								
CBS-72AT/ATC (-6)	160 lbs./hr.	10-15 PSI	120	2 + ground	4.5	6.0 gal.	2	10
Customer supplies one ¼ inch steam line. No power management between sides.								
CBS-72AT/ATC (-7)	80 lbs./hr. per side	10-15 PSI	120	2 + ground	4.5	6.0 gal.	2	10
Customer supplies two ½ inch steam lines. No power management between sides.								
CBS-72AT/ATC (-8)	80 lbs./hr.	10-15 PSI	120	2 + ground	4.5	6.0 gal.	2	10
Customer supplies one ½ inch steam line. With power management between sides.								

Each CBS-72 is actually two separate brewers in one body. Each side has a separate water tank and steam coil. The power management feature allows only one side of the brewer to heat at any given time, which limits the steam demand required for operation.

**All steam heated brewers are supplied with the following:**

- Steam inlet strainer, with ½" FPT  
(¾" FPT on CBS-72A/AT (-6) )
- Steam trap, with ½" hose barb
- Standard 3 wire power cord for 120 VAC outlet.

# Installation

(For Qualified Service Technicians Only)

## Keys To A Successful Installation

If not installed correctly by qualified personnel, the brewer will not operate properly and damage may result. Damage resulting from improper installation is not covered by the warranty.

Here are the key points to consider before installation:

### Electrical:

- All FETCO brewers require **NEUTRAL**. Ground is not an acceptable substitute. Installation without neutral may cause damage to the electronic components.
- The power connection to L1 on the terminal block must be at least 105 volts. Less than 105 volts will cause erratic behavior from the brewer.
- Push button circuit breakers are located on the front of the brewer, behind the dispensers.

### Plumbing:

- This equipment is to be installed to comply with the applicable federal, state, or local plumbing codes.
- The water line must be flushed thoroughly prior to connecting it to the brewer to prevent debris from contaminating the machine.

### General:

- Utilize a qualified beverage equipment service technician for installation.

## Brewer Installation

The installation must comply with applicable federal, state, and local codes having jurisdiction at your location. Check with your local inspectors to determine what codes will apply to the installation and operation of FETCO products.

### Brewer Set-up

- Place the brewer stand (for mobile cart systems) or counter (for stationary systems) in the desired location. Allow at least 1 foot of space between the wall and the back of the stand or counter. For easy access and visibility, electrical shut off switches, circuit breakers, water valves, and filters should not be located directly behind the brewer.
- Using a carpenter's level, adjust the legs until the stand or counter is perfectly level front-to-back, and left-to-right.
- Each leg has a flange with 2 holes for bolting the stand or counter to the floor (required for safety). Mark the location of the holes on the floor.
- Set the stand or counter aside, and drill holes in the floor as marked. The materials used will depend on the floor material.
- Bolt the stand or counter to the floor, and double check to make sure it is level.
- The brewer is shipped lying on its' back. Before standing it upright, remove the front cover. There is no need to remove the 2 top covers.
- Place the brewer on top of the stand or counter. This requires at least 3 people, 4 if possible.
- Bolt the brewer to the stand or counter, using the nuts and bolts provided.

### Drip Tray Drain Connection (stationary systems only)

- A kitchen sink style drain is provided on the drip tray for connection to a 1 ½ inch drain pipe.
- Before connecting the drain, the customer should select one of the three available height positions for mounting the drip tray. Holes are provided in the back of the counter for each of the available positions.

### Water connection

- **Caution!** The hose barb fitting(s) protruding from the back of the unit are the tank drains. DO NOT connect the incoming water to these fittings.
- The water connection is a single 3/8 inch male flare fitting, located inside the lower compartment.
- The brewer can be connected to a cold or hot water line. Cold water is preferred for best coffee flavor, but hot water will allow for faster recovery times.

- Install a water shut off valve near the brewer to facilitate service. If an in-line water filter is used, it should be installed after the water shut off valve and in a position to facilitate filter replacement.
- Before connecting the water line to the brewer, flush the line and water filter thoroughly to remove any debris.
- Connect the water line to the brewer, and turn on the water to check for leaks.

### Electrical connection

(Steam heated brewers - see next section)

- Verify that the actual voltage at the electrical service connection is compatible with the specifications on the brewer's serial number plate. Make sure the electrical service includes **neutral**.
- A fused disconnect switch or circuit breaker on the incoming power line must be conveniently located near the brewer, and its location and markings known to the operators.
- The body of the brewer must be grounded to a suitable building ground. A ground lug is provided in the brewer next to the power terminal block. Use only 10 gauge copper wire for grounding.
- Make sure that both power switches are in the "off" position. The buttons should be in the "out" position.
- Connect the power, neutral, and ground wires to the terminals in the brewer.

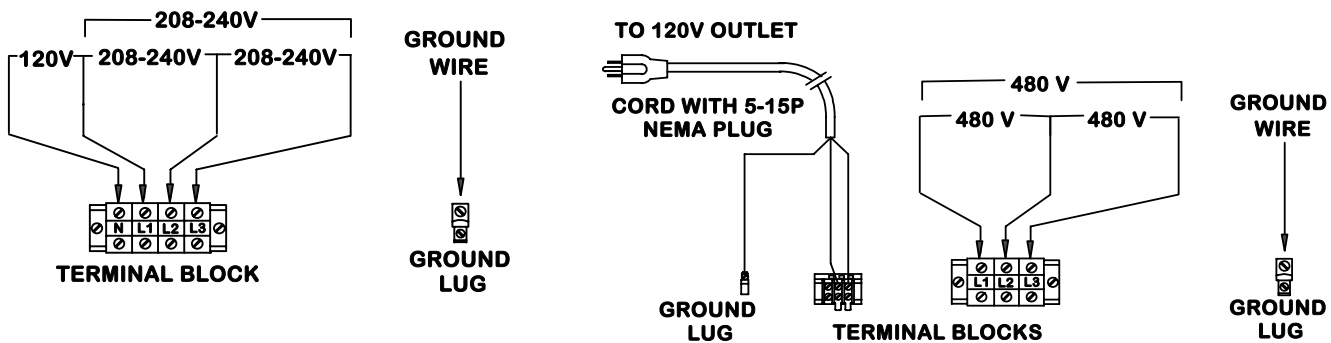

### Electrical Connection - 240 volts, 3 phase

### Electrical Connection - 480 volts, 3 phase

- Turn on the building circuit breaker. **Do not turn on the brewer's power switches yet.**
- At the brewer's terminal block, verify that the correct voltage is between terminals, according to the diagram above.
- CBS-71A - press the power switch. CBS-72A - press only the power switch on the brewer's left side. The power switch will illuminate. After a delay of 5-6 seconds, the tank should begin filling with water.
- CBS-72A - You can press the right side power switch at any time to begin filling the other tank, but this will cause the first tank to fill more slowly. To fill the first tank as fast as possible, wait until it has filled completely before pressing the right side power switch.
- The heating process will begin after the water has reached a safe level, but before the tank has filled completely. Approximately 10-15 minutes after the tank has filled, the ready light will illuminate, indicating that this side of the brewer is at the proper temperature and ready to operate.

## Steam Heated Brewers

### Electrical connection

- The electrical connection is 120 VAC, single phase, 2 wire plus ground. A power cord with a standard 5-15P plug is provided. The brewer will draw a maximum of 2.5 amps.

### Steam connection

- The steam line must be clean and free of any debris. A shut off valve should be located near the brewer.
- The steam inlet is ½ " or ¾" FPT, and is equipped with a strainer. There are two steam traps with ½ hose barbs.
- The steam pressure should be at least 10 PSI, and **must not exceed 15 PSI.**
- A shut off valve should be located near the brewer.
- To prevent backups, the ends of the hoses connected to the steam traps must be free (not connected or submerged).

## **Transfer System (AT versions only)**

### **Holding Tank Set-up**

- Place the tank stand in the desired location.
- Using a carpenter's level, adjust the legs until the stand is perfectly level front-to-back, and left-to-right.
- Each leg has a flange with 2 holes for bolting the stand to the floor (required for safety). Mark the location of the holes on the floor.
- Set the stand aside, and drill holes in the floor as marked. The materials used will depend on the floor material.
- Bolt the stand to the floor, and double check to make sure it is level.
- Place the holding tank on top of the stand.
- The tank's rear legs have flanges with 2 holes for bolting the tank down.
- Level the tank, and bolt it to the stand.
- Connect the two stainless steel shielded transfer hoses between the brewer and the holding tank.

### **Water Connection - Tank Rinse System**

- The tank must be connected to a hot water line. A minimum of 50 PSI is required. Before connecting it, flush the line thoroughly to remove any debris.
- The connection is a ½ inch male flare fitting, located on the left side of the tank, near the bottom. The flare fitting can be removed, leaving a ½ inch FPT connection.
- Before connecting the water line, make sure that the rinse jet valve on the front of the tank is in the "off" position. (The tank cover must be in place whenever the rinse jet valve is turned on.)

### **Tank Overflow Connection**

- Connect a ¾ inch I.D. hose to the overflow fitting on the right side of the tank. The opposite end of the hose should be free, not connected or submerged.

### **Drip Tray Drain Connection**

- A kitchen sink style drain is provided on the drip tray for connection to a 1 ½ inch drain pipe.

# Operating Procedures

## Brewing System

***Before brewing, always verify the cleanliness of the brew baskets and dispensers.***

**1. Push the POWER switch to the ON position**

- The button will illuminate to indicate that the brewer has power and is operational.

**2. Prepare the brew basket(s).**

- Carefully pull open the drawer holding the brew basket.
- Grasp the brew basket by one handle, and turn it until you can reach both handles comfortably.
- Grasp both handles and lift the basket out of the drawer. If necessary, empty and rinse the brew basket.
- Place a paper filter in each basket to be used. Pour the appropriate amount of pre-measured, ground coffee into the filter. Spread the coffee evenly in the basket until it is a uniform depth. (The amount of coffee used will depend on your personal tastes and the recommendation of your coffee supplier.)
- Place the brew basket back into the drawer. Turn the brew basket to align either one of the handles with either front corner of the drawer.
- Close the drawer completely. When fully closed, it will be flush with the front surface of the brewer.

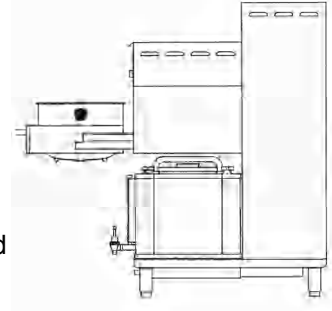

**3. Place the appropriate dispenser(s) in position under the brew baskets.**

- Ensure that the brew-through cover is in place, the dispenser is empty enough to handle the amount of coffee to be brewed, and the faucets are closed.
- Ensure that the dispensers are pushed all the way in, and that the brew funnels are aligned with the bottom of the brew baskets.
- When using carts, always set both parking brakes by pressing your foot on the paddle just above each of the two wheels closest to you. When the brakes are set, a green button extends above the paddle. To release the brakes for moving, press the green button with your foot.

**4. When the READY light is on, press the BREW button to start the brew cycle**

- The brew cycle will begin immediately, and the **BREW** button will illuminate. The brew cycle cannot be started unless the **READY** light is on.
- **Drip delay:** When the brew cycle is finished, the **BREW** button will flash during the drip delay cycle, indicating that coffee may still be dripping from the bottom of the brew basket.

**Optional BREW WAIT setting (See Programming section)**

- If the BREW WAIT setting is ON, and the **READY** light is off when the brew button is pressed, the **BREW** and **READY** lights will begin flashing. When the water has heated to the proper temperature, the **READY** light will go on, the brew cycle will begin, and the **BREW** button will illuminate with a steady glow.
- If necessary, you may stop the brew cycle at any time by pressing the **STOP** button. This will reset the brewer, and you will have to start a new brew cycle from the beginning.

**5. The RINSE button (labeled “FLUSH” on some units)**

- When this button is pressed, both the brew and bypass valves will open, allowing the maximum amount of water to flow into the brew basket. Water will flow only while the button is pressed.
- Used primarily to rinse the brew basket at the end of the day, it may also be used to pre-heat the brew basket before brewing.
- The flow of water will stop if the **RINSE** button is held in for more than 30 seconds. If a longer rinse time is desired, release the button momentarily and press it again.
- Caution! If the button is pressed too many times, the dispenser may overflow.

**CAUTION:**

- **Do not remove the brew basket or move the dispensers immediately after the brew cycle has finished. Wait until dripping from the bottom of the brew basket has stopped. This may take several minutes.**
- **When removing the brew basket, carefully inspect the inside of the basket for hot coffee that may have been trapped or has not finished draining.**
- **Always set both parking brakes whenever carts are not being transported.**

# Transfer System

## 1. Before Brewing

- Remove the sight gauge vent cap from the dispenser you want to transfer, and insert the transfer hose into the top of the sight gauge.
- Ensure that the dispenser, brew basket, and holding tank cover are in place, and that all old coffee has been drained from the holding tank and dispensers.
- Ensure that the Transfer, Automatic switch is in the "OFF" position, and that the ready light is on.
- Unlock and turn the rinse jet valve on the front of the holding tank to the "on" position to pre-heat the tank.
- Press and hold the Rinse (or FLUSH) button on each brew head for approximately 30 seconds.
- Press and hold the manual transfer button on each side until the dispensers are empty to pre-heat and rinse the transfer lines. (The flow of water will stop if the button is held in for more than 30 seconds. If a longer time is desired, release the button momentarily and press it again.)
- Turn the rinse jet valve to the "off" position.
- Open the lower faucet on the holding tank until the tank has drained completely.

## 2. Automatic transfer

- Set the Transfer, Automatic push button above the brew head you wish to transfer to the "ON" position. This can be selected at any time during the brew cycle. The system will wait until the brew cycle is completed, then automatically transfer the entire contents of the dispenser to the holding tank.

## 3. Manual transfer

- After a brew cycle has stopped, you can transfer coffee with the manual button in 2 ways:
  - Set the Transfer, Automatic switch to the "ON" position, and momentarily press the manual transfer button. This will start a timed transfer just as if the transfer had been selected during the brew cycle.
  - Set the Transfer, Automatic switch to the "OFF" position, and hold the manual transfer button in until the transfer is complete.
- The flow of water will stop if the manual transfer button is held in for more than 30 seconds. If a longer transfer time is desired, release the button momentarily and press it again. Repeat as needed.

## 4. Stopping the transfer

- You can stop the brew and transfer cycles on either side by pressing the appropriate stop button, or by pressing the appropriate power button to the off position. You can also shut down both sides at the same time by pressing the emergency stop palm switch in the center of the brewer. If you stop the brew head in the middle of a brew cycle, you will have to begin a new brew cycle from the beginning. You cannot restart a brew cycle after it has been stopped. If you stop the brew in the middle of a transfer cycle, you can finish the transfer by holding in the Transfer, Manual push button.
- Pressing the Emergency stop push button will remove power to the brewer and cancel all functions on both sides. If the problem can be isolated to one side only, the power switch to the appropriate side can be turned off and the emergency stop switch reset. This will allow the good side of the brewer to continue to function.

## 5. Dispensing coffee from the holding tank

- The upper faucet is positioned to allow coffee to be dispensed at a slower rate than the lower faucet when the tank is nearly full. It will not drain the tank completely due to its' position.
- The lower faucet will dispense much faster than the upper faucet and will drain the tank completely. Use caution, especially when the tank is nearly full.

## 6. End of the day cleaning

- Ensure that the dispenser, brew basket, and holding tank cover are in place, and that all old coffee has been drained from the holding tank and dispensers.
- Ensure that the Transfer, Automatic switch is in the "OFF" position, and that the ready light is on.
- Unlock and turn the rinse jet valve on the front of the holding tank to the "on" position.
- Press and hold the Rinse (or FLUSH) button on each brew head for approximately 30 seconds.
- Press and hold the manual transfer button on each side until the dispensers are empty. (The flow of water will stop if the button is held in for more than 30 seconds. If a longer time is desired, release the button momentarily and press it again.)
- Turn the rinse jet valve to the "off" position.
- Make one full brew on each side, without coffee in the brew basket, and the Automatic Transfer OFF.
- Manually transfer approximately ½ of the water to the holding tank. This will flush hot rinse water through the entire system, leaving only clean, fresh water in the pump and lines. Leave the remaining water where it stands until the system is needed again.
- Remove the brew basket and wipe the area above the basket with a cloth to remove any coffee oils.

# Programming

- ▶ Turn the power switch on.
- ▶ Hold the **SET** button for 3 seconds, until the display reads SET.
- ▶ The display will show 0.0 briefly, followed by the software version. Example: 10.A
- ▶ Press **SET**. The first parameter number will be displayed briefly, followed by the current setting.  
Example: 1.0 = Brew orifice, .312"  
Use the **UP** and **DOWN** buttons to adjust the setting.
- ▶ Press **SET** again. The next parameter will be displayed briefly, followed by the current setting.  
Example: Bypass percent, 0%  
Use the **UP** and **DOWN** buttons to adjust the setting.
- ▶ Continue this way until all parameters are programmed. See the chart below for an explanation of each parameter.
- ▶ Important! To save your changes and return to operating mode, you must hold **SET** for 3 seconds until the display reads STo.
- ▶ The unit will automatically return to normal operating mode after 30 seconds without programming activity, and changes will not be saved.

Display

SET

0.0

10.A

1.0

312

1.1

0

STo

## CONTROL BOARD

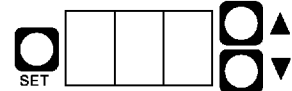

The display shows the actual water temperature when not in Programming mode.

### Error Codes

- 050 - Shorted Temp Probe
- 051 - Open Temp Probe
- 070 - Stuck switch  
(Switch stuck or held in for more than 45 seconds.)

Error codes are displayed on the control board. To reset, turn the power switch off and on.

Parameter	Name	Range	Increment	Standard Factory Setting <sup>1</sup>	Comment
0.0	Software Version				Displays current version.
1.0	Brew orifice size	Five available sizes: .250, .281, .312, .343, .375.		.312	This is the size of the hole in the brew orifice, which controls how fast water is dispensed. <sup>2</sup>
1.1	Bypass Percent	0.00 – 35.0%	5%	0 %	Percentage of total brew volume.
1.2	Drip Delay (Min:Sec)	1 – 5 minutes	10 sec.	1:30	Time between the end of the brew cycle and the brew light stops flashing.
1.3	Auto Transfer Pump	1 – 6 minutes	10 sec.	4:00	Transfer units only. This is the amount of time the transfer pump runs after a brew cycle when the “Auto Transfer” switch is on.
2.0	Water Temp. (°F)	180°F - 208°F	1°F	205°F	
3.0	Brew Wait	ON - OFF		OFF	OFF = Brewer must be at set temperature (READY light on) to start a brew cycle. ON = If the BREW button is pressed when the unit is not at the set temperture, the brewer will wait until it heats up, and then begin brewing. The READY and BREW lights flash during the waiting time.

<sup>1</sup> Standard factory settings apply unless custom settings were requested at the time of order.

<sup>2</sup> Non-standard size brew orifices must be ordered from FETCO.

# Cleaning & Maintenance

## Daily

Before brewing, always verify the cleanliness of the brew baskets and dispensers.

At the end of the day, remove the brew basket and wipe the bottom of the spray pan with a cloth to remove the coffee oils that have collected.

## Brew & Bypass Orifices

The flow of water through the brew and bypass orifices may gradually become restricted by the accumulation of mineral deposits. The orifices should be inspected periodically and cleaned if necessary.

To remove the orifices:

- Remove the brew basket and brew basket drawer.
- Grasp the sides of the spray pan with both hands and turn it counter-clockwise. Being careful not to drop it, continue turning it with both hands until it comes completely off.
- The brew orifice is located in the center of the threaded piece that held the spray pan. The bypass orifice is located to the right and to the rear of the brew orifice. Both orifices are stainless steel. Do not remove the brass fitting located in the same area. This is the vent from the water tank.
- Removal of either orifice requires a 11/16 inch wrench.
- Replace or clean the orifices and reassemble all of the parts.

## Transfer Systems: End of the day cleaning

- Ensure that the dispenser, brew basket, and holding tank cover are in place, and that all old coffee has been drained from the holding tank and dispensers.
- Ensure that the Transfer, Automatic switch is in the "OFF" position, and that the ready light is on.
- Unlock and turn the rinse jet valve on the front of the holding tank to the "on" position.
- Press and hold the Rinse (or FLUSH) button on each brew head for approximately 1 minute.
- Press and hold the manual transfer button on each side until the dispensers are empty.
- Turn the rinse jet valve to the "off" position.
- Make one full brew on each side, without coffee in the brew basket, and the Automatic Transfer in the OFF position.
- Manually transfer approximately ½ of the water to the holding tank. This will flush hot rinse water through the entire system, leaving only clean, fresh water in the pump and lines. Leave the remaining water where it stands until the system is needed again.
- Remove the brew basket and wipe the area above the basket with a cloth to remove the coffee oils that have collected.

# Parts

## Figure 1 – CBS-72A Main Assembly

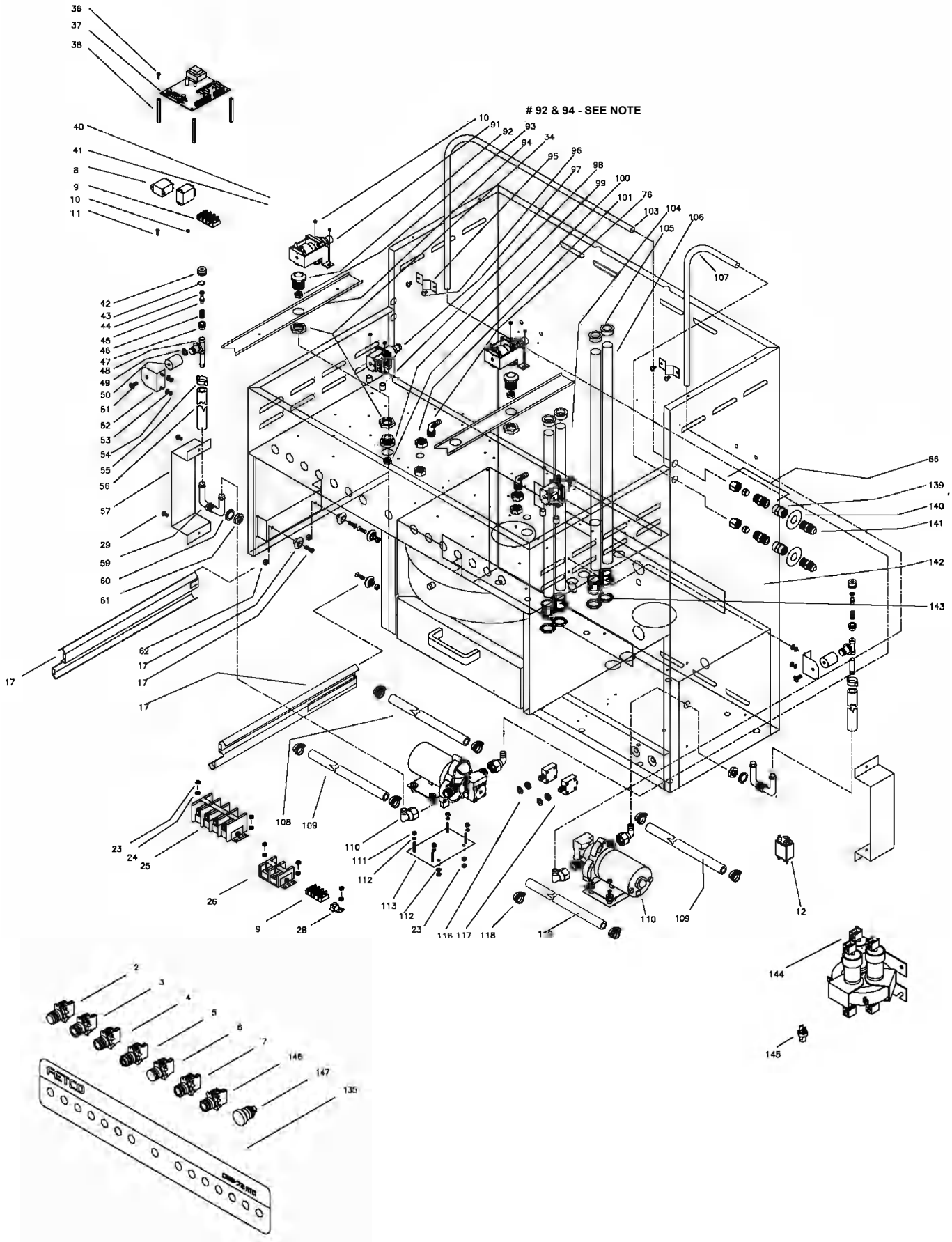

ITEM	QTY	PART NO.	DESCRIPTION
2	2	102235	ASSEMBLY, POWER SWITCH, CBS-70'S
3	2	102241	ASSEMBLY READY LAMP SWITCH, CBS-70'S
4	2	102237	ASSEMBLY, BREW SWITCH, CBS-70'S
5	2	102238	ASSEMBLY, STOP SWITCH, CBS-70'S
6	2	102242	ASSEMBLY, TRANSFER AUTO SWITCH, CBS-70'S
7	2	102239	ASSEMBLY, TRANSFER MANUAL SWITCH, CBS-70'S
8	4	52062	220V MECHANICAL RELAY KUP-11A55
8	4	52054	120V MECHANICAL RELAY KUP-11A55
9	4	64013	WIRE CONNECTOR 2-8, 600V, COOPER
10	41	84002	#8 HEX NUT
11	2	82053	#6-32 X 1/2" PHIL TRUSS HD.M.S. SCREW
12	1	52074	FILTER RFR POWER LINE
17	0	73022	CBS-70'S DRAWER SLIDE
23	10	84018	#10 HEX MACHINING NUT
24	2	83037	#10 S.S. SPRING LOCKWASHER WASHER
25	1	52051	CURTIS T-4 TERMINAL BLOCK
26	1	52052	CURTIS BT-2 TERMINAL BLOCK
28	1	65001	SLU-70 ILSCO COOPER LUG CONNECT.
29	24	82006	#10 -32 X 3/8 S.S. PHIL T.H. SCREW
30	1	01262	FRONT COVER
36	8	82053	#6 3/2 X 1/2 S.S. PHIL T.H. SCREW
37	2	108022	BOARD CONTROL
38	8	15004	1/4" HEX ALUMINIUM STANDOFF
42	2	13051	TRANSFER TEE CUP
43	2	24040	AS 56A NO.014 BUNA-N O-RING
44	2	24039	AS 56A NO.010 BUNA-N O-RING
45	2	21075	TRANSFER VENT PLUNGER
46	2	85008	PRECISION COMP.SPRING .360.D. X .026WIRE X 3/4"
47	2	12028	TRANSFER VENT HOUSING
48	2	002070	TRANSFER TEE WELDING
49	2	24041	3/32W X 7/16 I.D. X 5/8 O.D. BUNA NO.111 O-RING
50	2	13052	TRANSFER TEE NEST
51	2	82092	1/4-20 x 3/8 TRUSS HEAD SCREW
52	2	03247	TRANSFER TEE NEST BRACKET
53	8	83035	#8 LOCKWASHER
55	2	86034	13/16" TWO-EAR S.S. CLAMP
56	2	25052	.800 X .500 X 35.0" TRANSFERING TUBE
57	2	01478	CBS-70'S TRANSFER GUARD
59	2	002071	CBS-72ATC "U" TUBE WELDMENT
60	2	83050	LOCK WASHER METRIC SERRATED 16.5 MM X 26.0 MM
61	6	31118	3/8" LOCKNUT
62	8	84014	1/4-20 HEX NUT
66	4	31123	1/2 X 3/8 MALE CONNECTOR
76	4	31074	3/8 HOSE BARB X 3/8 MALE PIPE 90 DEG. ELBOW
91	2	57030	DSV10 220V/240 50/60HZ BREW VALVE
91	2	57029	DSV10 120V/60HZ BREW VALVE
92	2	33012	CBS-70'S DISPENSE VALVE FITTING
93	2	33021	CBS-70'S BREW ORIFICE
94	2	03251	CBS-70'S DISPENSE VALVE BRACKET
95	2	03250	CBSA-70'S TRANSFER PIPE HOLDER
96	4	82032	#8 -32 X 1/2" P.H. PHIL. SCREW
97	2	57032	DSV11 220/240 50/60HZ BY-PASS VALVE
97	2	57031	DSV11 120V/60HZ BY-PASS VALVE
98	4	86009	CBS-70'S BY-PASS VALVE SPACER
99	2	33013	BY-PASS VALVE FITTING
100	2	33020	BY-PASS ORIFICE
101	2	33016	HEX NUTS
103	1	32058	CBS-70'S COFFEE TRANSFER TUBE LEFT
104	2	32055	3/4 X 18" ELECTRIC TUBE SHORT
105	4	86032	1.0" HEYCO SNAP BUSCHING
106	2	32056	3/4- 28" ELECTRIC TUBE LONG
107	1	32058	CBS-70'S COFFEE TRANSFER TUBE RIGHT
108	1	25047	CBS-70'S .800 O.D. X .500 I.D. X 15.5" OUTPUT SILIKON TUBE
109	2	25048	CBS-70'S .800 O.D. X .500 I.D. X 17.0" INPUT SILIKON TUBE
110	2	55002	DIAFRAM TRANSFER PUMP 230V
110	2	55001	DIAFRAM TRANSFER PUMP 120V
111	8	84016	1/4-20 HEX NUT
112	16	83025	1/4" LOCKWASHER
113	2	03249	CBS-70'S TRANSFER PUMP BRACKET
116	2	52027	10A CIRCUIT BREAKER
117	2	52053	2A CIRCUIT BREAKER
118	8	86020	.875 MAX HEYCO CLAMP
119	1	25049	.800 O.D. X .500 I.D. X 11.5" L OUTPUT PUMP TUBE
120	2	01475	CBS-72 VENT COVER
121	1	01256	TOP CONTROL COVER
122	1	01263	CONTROL COVER
135	1	45034	OVERLAY
139	2	31181	3/8 FEM. PIPE COUPLING
140	2	83043	.688 X 1.125 WASHER
141	1	31182	ALKON 3/8 MPT X 1/2 FLARE MPT NIPPLE (AK4855 8 X6)
142	1	001029	CBS-72 BODY WELDMENT
143	4	86035	3/4 CONDUIT FITTING (McM)-7150K75)
144	2	52025	MERCURY RELAY, 60A
144	2	52041	MERCURY RELAY, 80A
145	12	64031	WIRE CONNECT. 14-2 COOPER SPLIT BOLT
146	2	102236	ASSEMBLY, RINSE SWITCH, CBS-70'S
147	1	102240	ASSEMBLY, EMERGENCY STOP SWITCH CBS-70'S
145	12	64031	WIRE CONNECT. 14-2 COOPER SPLIT BOLT
146	2	102236	ASSEMBLY, RINSE SWITCH, CBS-70'S
147	1	102240	ASSEMBLY, EMERGENCY STOP SWITCH CBS-70'S

NOTE: #92 & 94 ARE WELDED TOGETHER. ORDER PART# 002077 - DISPENSE VALVE FITTING WELDMENT

**Figure 2 – CBS-72A Tank Assembly**

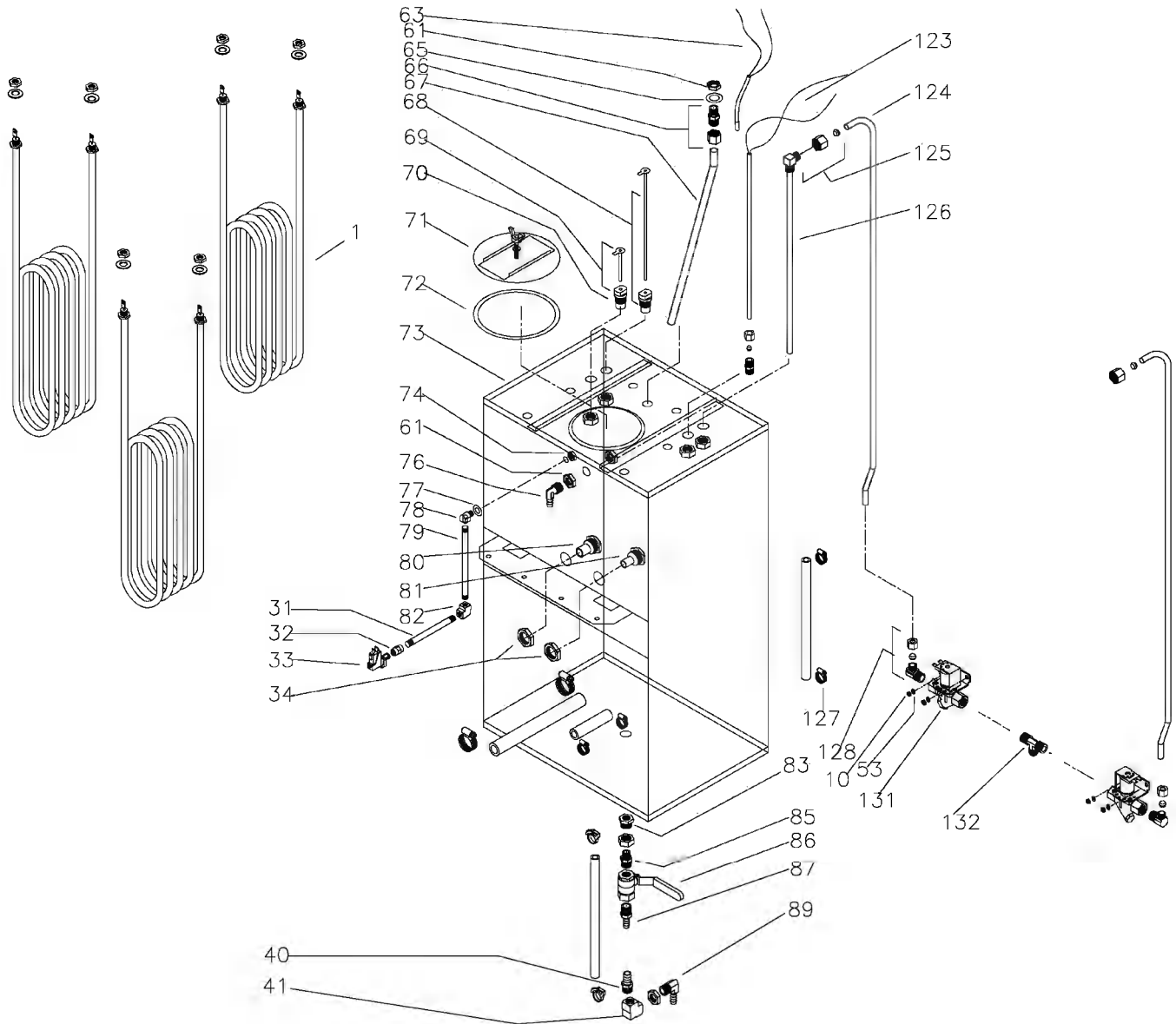

ITEM #	QTY	PART #	DESCRIPTION
1	3	107010	ASSEMBLY, IMMERSION HEATER, 5000W, 240VAC
1	3	107009	ASSEMBLY, IMMERSION HEATER, 10000W, 480VAC
1	3	107008	ASSEMBLY, IMMERSION HEATER, 10000W, 240VAC
10	4	84002	NUT, HEX, 8-32
31	1	31121	NIPPLE, PIPE, 1/8", 4.25"LG
32	1	31113	COUPLING 1/8"
33	1	58035	SWITCH, PRESSURE, 2PR
34	2	33016	LOCKNUT, 1-1/16"
40	1	31054	FITTING, 1/2 HOSE BARB X 3/8 MPT
41	1	31104	FITTING, EXTRUDED FPT ELBOW, 3/8 X 3/8
53	4	83035	WASHER, #8 LOCK
61	3	31118	LOCKNUT, 3/8"
63	1	102114	THERMAL CIRCUIT BREAKER
65	1	83041	WASHER, 0.812" O.D X 0.412 I.D
66	1	31123	FITTING, MALE CONNECTOR 1/2 X 3/8

67	1	32054	TUBE, THERMAL CIRCUIT BREACKER
68	1	002229	WELDMENT, WATER LEVEL PROBE, 9,0" LG
69	1	002050	WELDMENT, WATER LEVEL PROBE, 2.5" LG
70	2	21026	HOUSING, WATER LEVEL PROBE
71	1	102115	ASSEMBLY, TANK COVER
72	1	24014	GASKET, TANK
73	1	004020	WELDMENT, TANK, CBS-72
74	1	31116	LOCKNUT, 1/8"
76	1	31074	FITTING, 3/8 HOSE BARB X 3/8 MALE PIPE 90 DEG ELBOW
77	1	83041	WASHER, 0.812 O.D X0.412I.D. FLAT
78	1	31120	FITTING, 1/8 STREET 90 DEG. ELBOW
79	1	31122	NIPPLE, PIPE, 1/8"
80	1	33014	FITTING, TANK BREW VALVE
81	1	33015	FITTING, TANK, BY-PAS
82	1	31114	FITTING, ELBOW, EXTRUDED, 90 DEG
83	1	31021	BUSHING, 3/4-16X 1/4,NPSM HEX HEAD
85	1	31082	FITTING, HEX NIPLE, 3/8MPT X 1/4 MPT
86	1	34004	VALVE, BALL, 3/8
87	1	31054	FITTING, 1/2 HOSE BARB X 3/8 MPT
89	1	31101	FITTING, BARB 1/2 HOSE I.D. X 3/8 MPT
123	1	102279	ASSEMBLY, DIGITAL TEMP. PROBE, 14" LG, W/52" CABLE
124	1	32059	TUBE, COLD WATER
125	1	31027	FITTING, COMPR.90DEG ELBOW, 3/8TUBE O.D.X 1/4MPT
126	1	002072	WELDMENT, TANK WATER INLET TUBE
127	4	86016	CLAMP, WPRM DRIVE, HEYCO, 0.562-1.062
128	2	31055	FITTING, ELBOW, 3/8COMPR. X 3/8 MPT
131	2	57001	VALVE, S-45, 120VAC, 3/8 NPTX 3/8 NPT91.35GAL/MIN)
132	1	31119	FITTING, FLARED TEE, 3/8 MPT X 3/8 MPT X 3/8 TUBE O.D.
133	1	25050	TUBE, VENT, .375 I.D. X .655 O.D.X 13.5 LG
134	2	86015	CLAMP, WORM DRIVE, HEYCO, 1.062-1.25
136	1	25053	TUBE, BY-PASS, .500 X .800 X 3.375" LG
137	1	25054	TUBE, BREW VALVE, .625 X .965 X 8.625 LG
138	1	25051	TUBE, DRAIN, 3/8 X 5/8 X 10.0" LG
148	1	54029	SENSOR, DIGITAL TEMP. PROBE, W/52" CABLE
149	1	24057	PLUG, RUBBER, DIGITAL TEMP. PROBE
150	1	13091	HOUSING DIGITAL TEMPERATURE PROBE, 14.0" LG
151	1	31036	FITTING, COMPR. MALE CONNECTOR, 1/4 TUBE X 1/4 MPT

**Figure 3 – CBS-72A Brew Basket Assembly**

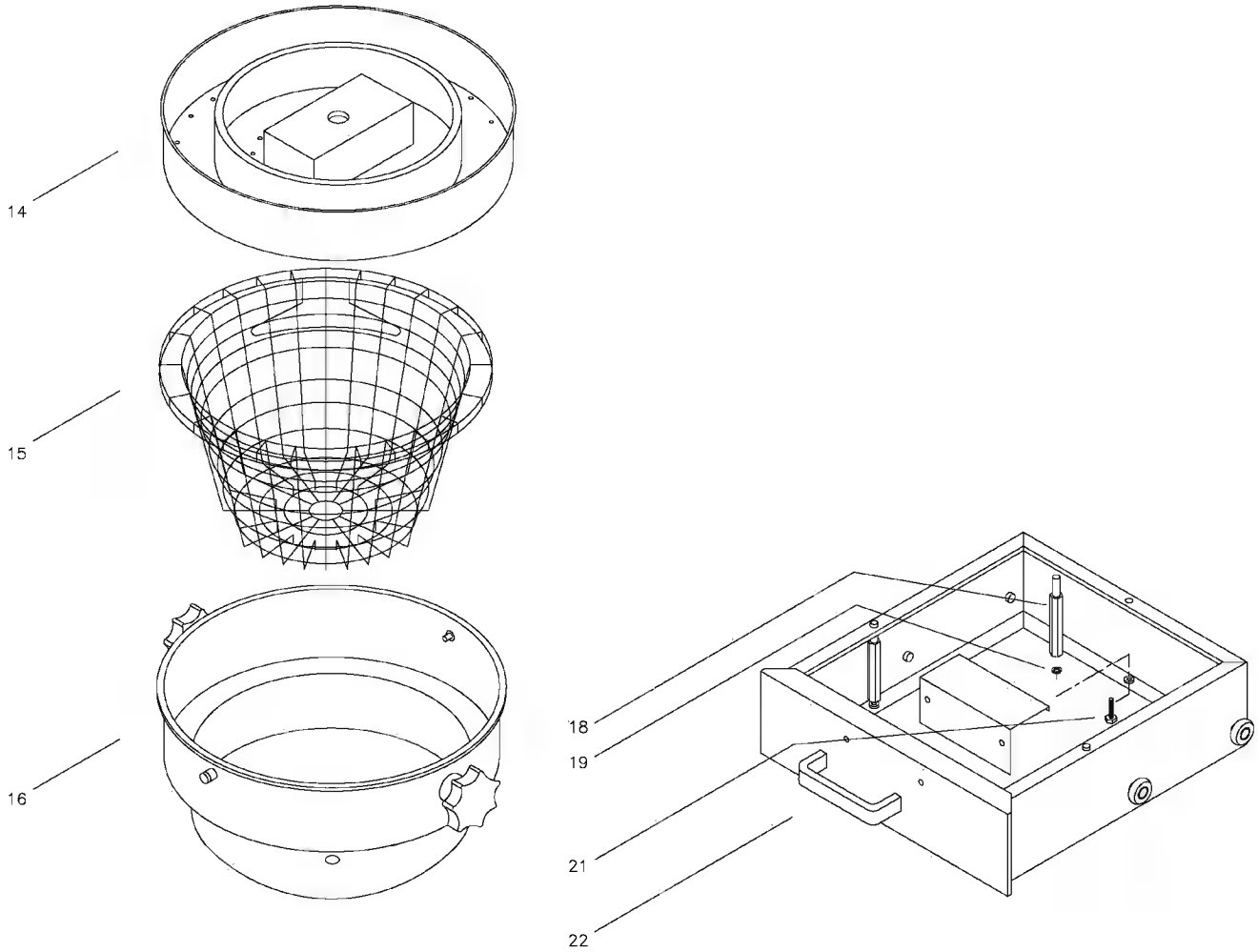

ITEM #	QTY	PART #	DESCRIPTION
14	1	002069	SPRAY PAN, CBS-70'S
15	1	09011	WIRE BASKET, CBS-70'S
16	1	101134	BREW BASKET ASSEMBLY, CBS-70'S
18	3	21076	BREW BASKER HEIGHT REGULATOR
19	3	83025	SPRING LOCK WHASER, 1/4"
21	0	82044	STAINLESS STEEL HEX CAP SCREW, 1/4-20 X 1.0"LG
22	0	102113	DRAWER ASSEMBLY, CBS-70'S

Figure 4 – LBD-6C Assembly

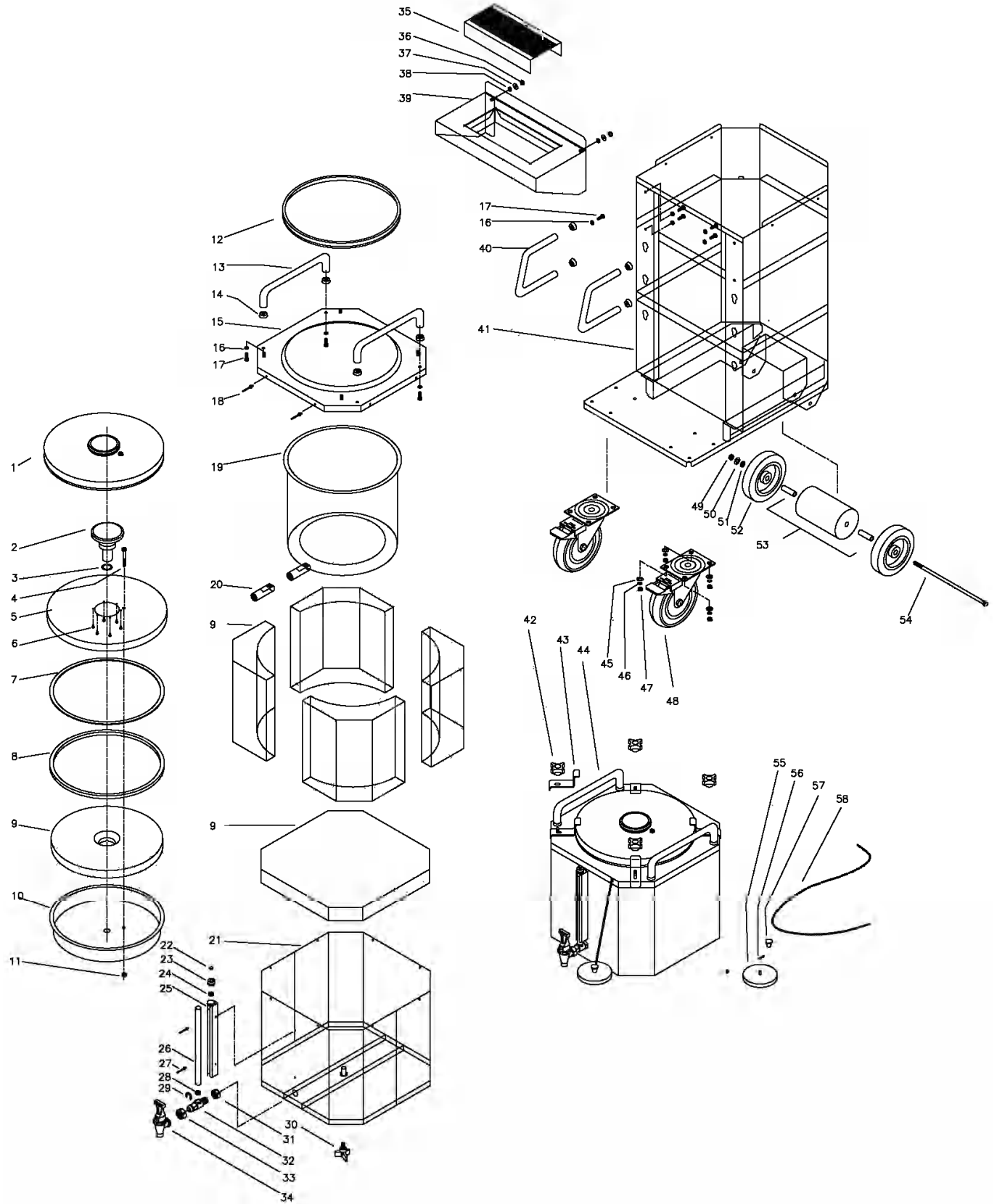

ITEM #	QTY	PART #	DESCRIPTION
1	1	102111	LBD-6 COVER ASSEMBLY
2	1	23044	6 GAL. DISPENSER FUNNEL
3	1	24034	1.00" I.D. X 1.25 O.D. O-RING
4	1	13050	LBD-6 VENT SCREW
5	1	04053	DISPENSE COVER TOP
6	6	82032	3/8"X 1/2" S.S. PAN HEAD PHIL. SCREW
7	1		SEALING TAPE
8	1	24015	CBS-70'S 6GAL. DISPENSE COVER GASKET
9	1	22016	6 GAL. DISPENSER INSULATION SET
10	1	04054	LBD-6 GAL.DISPENSER COVER BOTTOM
11	1	84028	5/6-18 NYLON INSERT LOCKNUT
12	1	24016	6 GAL.DISPENSER LINER GASKET
13	2	72007	6 GAL. DISPENSER HANDLE
14	4	13039	HANDLE STAND OFF (SMALL)
15	1	01340	6 GAL. DISPEPENSER TOP
16	4	83025	1/4 S.S. LOCKWASHER
17	4	82055	1/4 - 20 X 3/4" HEX HD. CAP SCREW
18	8	82012	3/16" DIA. SEALING BLIND RIVET
19	1	003007	6.GAL. DISPENSER WELDMENT
20	1	13096	SHANK, LINER, LBD-6
21	1	001028	LBD-6 BODY WELDMENT
22	1	71025	SHIELD CUP PLUG #44
23	1	71024	SHIELD CUP
24	1	71018	GAUGE UPPER WASHER
25	1	002068	GAUGE HOUSING WELDMENT
26	1	21034	GAUGE TUBE 11.5"
27	2	87009	5/32 DIA. X .270 L. POP BLIND RIVET
28	1	71017	LOWER GAUGE WASHER
29	1	71036	C-RING
30	1	72018	6GAL. MOBILE DISPENSER LOCK
31	1	13015	3/4-20 SHANK LOCKNUT
32	1	13014	1.5 GAL. SHANK W GAUGE NEST
33	1	31045	1/2 NPS UNION NUT
34	1	71026	FAUCET, COMPLETE, ES SERIES
34	1	71037	FAUCET UPPER ASSY. (INCLUDES BLACK HANDLE, SEAT CUP, SPRING, BONNET)
34	1	71035	FAUCET SEAT CUP
34	1	71028	FAUCET HANDLE, BLACK
34	1	71027	FAUCET HANDLE, ORANGE
35	1	01336	CBS-71 COUNTER OR 6GAL.SERV.CART DRIP TRAY
36	2	84015	5/16-18 HEX NUT
37	2	83019	5/16" FLAT WASHER
38	2	83020	5/16 LOCKWASHER
39	2	01329	6 GAL. SERVING CART SINK
40	2	72008	SERVING CART HANDLE
41	1	001028	6 GAL. SERVING CART WELDMENT
42	4	72012	6 GAL. DISPENS. COVER KNOB
43	4	01437	6 GAL. DISPENSER COVER LOCK
44	2	101164	LBD-6 ASSY
45	1	83019	5/16" FLAT WASHER S.S.
46	4	83020	5/16" SPRING LOCK WASHER

47	4	84015	5/16"-18 HEX NUT
48	1	73024	6 GAL. CONTAINER CASTER, SWIVEL
49	8	84022	3/8-16 MACHINE SCREW NUT
50	8	83031	3/8" S.S FLAT WASHER
51	8	83032	3/8" REGULAR SPRING LOCKWASHER
52	2	73025	6 GAL. CONTAINER CASTER
53	1	14011	LBD-6C BALANCE WEIGHT
54	1	82063	3/8-16 X 12" HEX HD. CAP SCREW ZINC PLATED
55	2	06010	FUNNEL COVER
56	1	82042	ROUND BEAD CHAIN FITTING #8-10
57	1	72006	FUNEL CUP KNOB
58	1	82041	#6 ROUND CHAIN

