

# Replacement Parts



## List EmberGlo® Steamer Models ES5M, ES5M18 & ES5MT

*Tap Water Operation  
Designed to Operate  
Without Distilled Water  
Self Contained Water Supply*



Manual Operation Steamer with Water Pan

Installation and Service Manual - 8449-96

Date Code - Model ES5M first construction May 1983

Model ES5M18 first construction October 2005

Model ES5MT (Tortilla Model) first construction February 2013

Items listed are replacement parts for the current Models ES5M and ES5MT Tap Water Steamer and its components.

- EmberGlo Steamers do not require a separate hood for vapor produced during operation according to the Uniform Mechanical Codes per the International Conference of Building Officials Code.

<i>Models</i>	<i>Description</i>	<i>Volts</i>	<i>BOMs</i>
<i>1500W</i>			
ES5M	Manual Operation with Water Pan	120V	<a href="#">5400703</a>
ES5M	Manual Operation with Water Pan	240V	5400704
ES5MT	Manual Operation with Water Pan and Specially Perforated Tortilla Food Pan	120V	5400709
<i>1800W</i>			
ES5M18	Manual Operation with Water Pan	120V	5400710



**EmberGlo®**

EmberGlo  
A Div of Midco® International Inc.  
4140 West Victoria Street  
Chicago, Illinois 60646  
toll free 866.705.0514  
tel 773.604.8700  
fax 773.604.4070  
web [www.emberglo.com](http://www.emberglo.com)  
e-mail [sales@emberglo.com](mailto:sales@emberglo.com)

**AVOID ERROR IN PARTS SELECTION.** When ordering use complete MIDCO Part Number and Description. Furnish Burner Model Number, Bill of Material Number and Serial Number (if available) from the specification plate found on the product.

**IMPORTANT:** Availability of parts as well as specifications are subject to change without notice. Please consult factory for item availability.



As an ISO 9001:2008 certified company, we proudly design, manufacture and assemble our products in Chicago, Illinois, USA.

*Quality Designed for Proven Performance*

825  
8472 50  
Printed in USA

# ES5M & ES5MT Exploded View

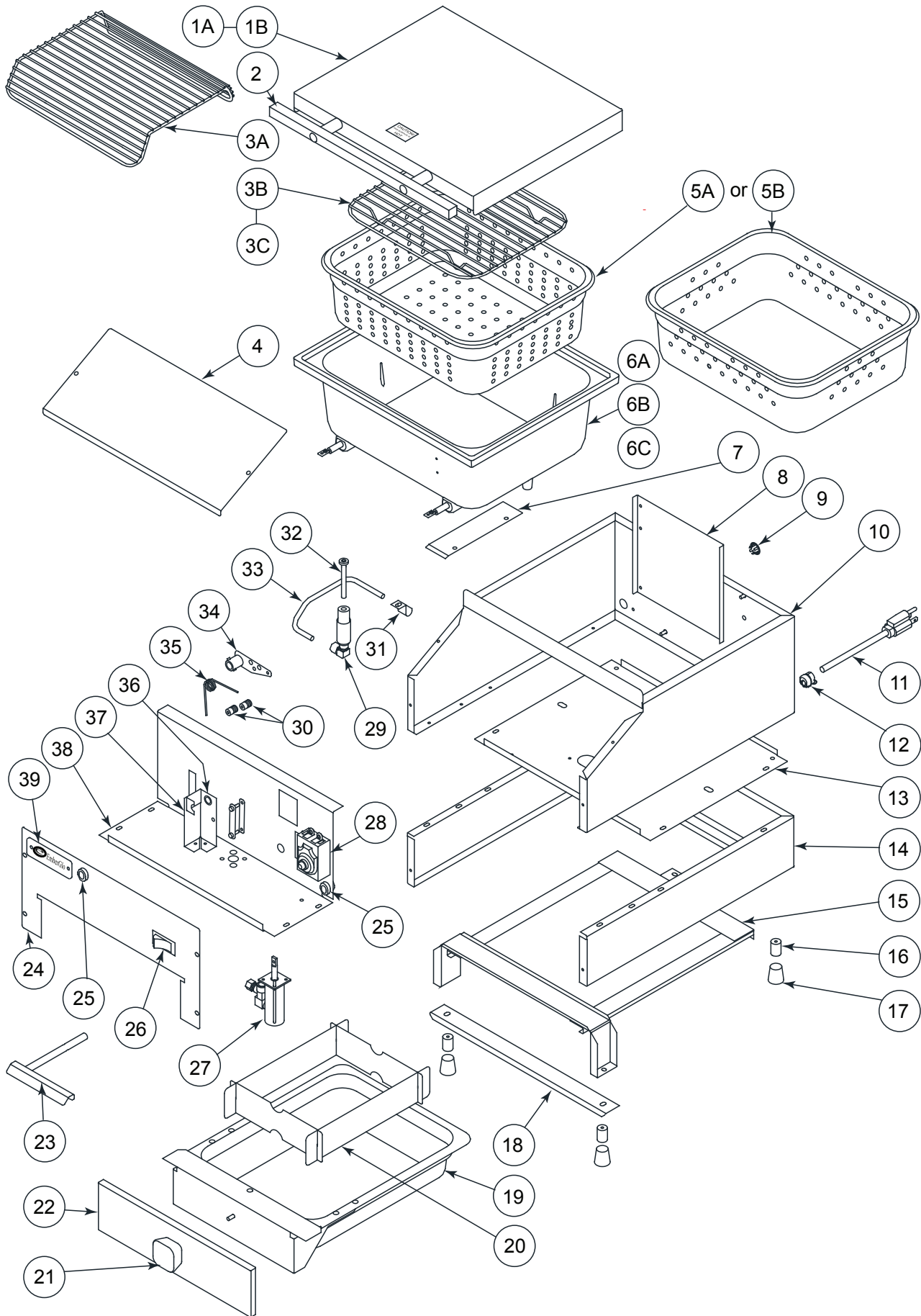

# ES5M, ES5M18 & ES5MT Parts List

#	Part #	Description	Qty	#	Part #	Description	Qty
1A	1420-80R	Lid Assembly	1	27	1405-30	Pump Assembly	1
1B	1420-81R	Lid Assembly - 1800 Series ONLY	1	28	1412-41	Thermal Fuse/ Thermostat Kit	1
2	1435-00	Lid Handle Replacement Kit	1	29	1402-70	Water Inlet Assembly	1
3A	5682-60	Tortilla Grid	1	30	1408-01R	Spring Seat	2
3B	5608-50	Food Pan Grid	1	31	1409-60	Tube Clip	1
3C	5608-51	Food Pan Grid 1.5" Tall	1	32	1411-20	Water Nozzle with Spring	1
4	1401-21	Control Box Cover - ES5	1	33	1410-90	Water Tube Assembly	1
5A	8452-64	Perforated Pan Half Size 4" Deep (ES5MT)	1	34	1407-40	Pump Crank Assembly	1
5B	1401-90	ES5 Food Pan	1	35	8451-52	Torsion Spring	1
6A	1401-61	ES5 Generator - 220V, 1500W	1	36	8450-19	3/8" Nylon Insert	1
6B	1401-63	ES5 Generator - 120V, 1800W	1	37	1404-80	Pump Handle Support	1
6C	1401-64	ES5 Generator - 120V, 1500W	1	38	1404-41	Manual Front Bottom - 1800 Watts	1
7	1401-30	ES5 Bulb Clamp	1	39	5622-00	Name Plate	1
8	1409-00	Stiffener	1				
9	8451-89	Plug Button HS51156-K1110	1				
10	1400-40	Shell Weldment	1				
11	1403-70	ES5 Power Cord-120V	1				
12	8457-46	Strain Relief	1				
13	1401-10	Rear Bottom	1				
14	1407-10	Water Pan Shell Weldment	1				
15	1406-50	Water Pan Slide Weldment	1				
16	5661-80	Aluminium Leg	4				
17	8450-25	Socket Tip	4				
18	1407-70	Leg Channel	1				
19	1402-10	Water Pan Rivetment	1				
20	1411-00	Water Pan Baffle Set	1				
21	8445-01	Cover Knob	1				
22	1408-90	Water Pan Front	1				
23	1400-20	Pump Handle Replacement Kit	1				
24	1403-90	Switch Panel - Manual - ES5M	1				
25	8484-76	Shorty Bush B-500-375	2				
26	1435-03	On/Off Rocker Switch Kit	1				

### The Following Are Not Shown

1410-60	Electrical Wire Kit (less power cord)	1
1420-00	Spring bar	2
1421-45	Back Hinge Kit (less spring bar & spring)	1
8451-09	15/16" U Cups	2
1420-40	ES5 Hinge Spring	2

### Accessories - Not Shown

5682-60	Tortilla Rack Grid Style
5608-55	Tray Separator Stainless Steel
5608-70	Three in 1 Basket Kit w/ Handle
5608-72	1/2 Size Basket w/ Handle
5608-73	Two of 1/4 Size Basket w/ Handle
5609-15	1/2 Size Perforated Food Pan
2070615	Egg Poacher 6 Cup
2070610	Egg Poacher 4 Cup
8450-62	Steam Generator Cleaning Brush

## ADJUSTABLE HINGE FOR 2-POSITION LID OPENING (60° OR 90° OPEN)

First construction January 29, 1990 (date code 0590). Steamers built before this date featured a 90° opening lid. Replacement parts for the early construction are no longer available. When replacing order Part Number 1421-45 ADJUSTABLE HINGE RETROFIT KIT.

#	Part #	Description	Qty
1	1421-40	Adjustable Upper Hinge	1
2	1421-51	Lid Stop Rivetment	1
3	1421-41	Upper Hinge Bar	1
4	1421-01	Adjustable Lower Hinge	1
5	8432-08	5/16" x 3/16" O-Ring	2
Not Shown - (Sold Separately)			
	1420-00	Spring bar	2
	1420-40	ES5 Hinge Spring	2

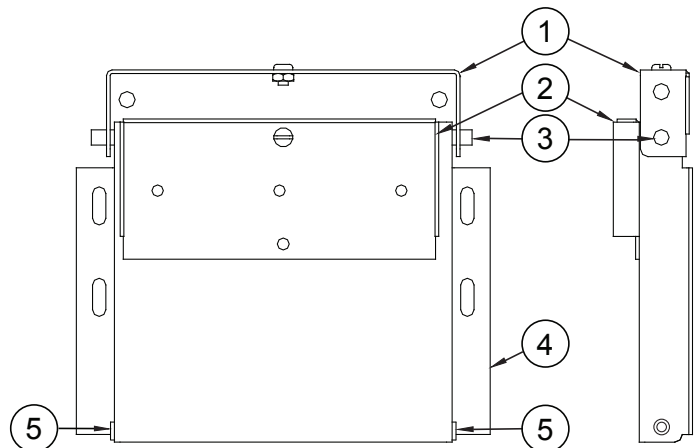

# ES5M, ES5M18 & ES5MT

---



*As an ISO 9001:2008 certified company, we proudly design, manufacture and assemble our products in Chicago, Illinois, USA.*

EmberGlo - A Division of Midco International - 4140 West Victoria Street - Chicago, Illinois 60646

toll free: 866 705 0515 - tel: 773.604.8700 - fax: 773.604.4070 - web: [www.emberglo.com](http://www.emberglo.com) - e-mail: [sales@emberglo.com](mailto:sales@emberglo.com)



825  
**8472 50**  
Printed in USA