

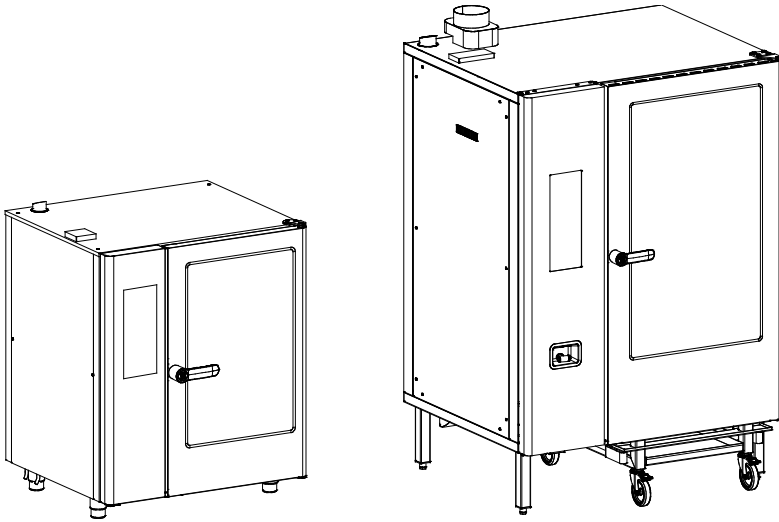

**eloma**



# Genius<sup>MT</sup>

Sizes: 6-11, 10-11, 20-11, 12-21, 20-21

Type of energy: Gas and electric

## Installation instructions

Subject to technical changes.  
Read carefully before use.  
Keep for future use.

## Imprint

Eloma GmbH . Innovative cooking and baking technology  
Otto-Hahn-Str. 10  
82216 Maisach  
Germany

Phone: +49 (0) 8141 395-0

Fax: +49 (0) 8141 395-130

## Cooking forum and user tips

Website: [www.eloma.com](http://www.eloma.com)

User hotline: +49 (0) 35023 63887

## Service

Service hotline: +49 (0) 35023 63888



Appliance type: .....

Appliance no.: .....

**Dealer:**

**Installer:**

Date: .....

Installed on: .....

## Table of Contents

<b>1</b>	<b>About this document .....</b>	<b>5</b>
1.1	Content and target audience .....	5
1.2	Handling this document.....	5
1.3	Symbols used and layout of warnings .....	5
1.4	Use of images.....	6
1.5	Warranty and disclaimer of liability .....	6
1.6	Models.....	7
<b>2</b>	<b>Safety .....</b>	<b>8</b>
2.1	Qualifications of installation staff .....	8
2.2	Safety information.....	8
2.3	What to do in the event of a gas leak (with gas appliances) .....	11
<b>3</b>	<b>Planning the installation .....</b>	<b>12</b>
3.1	Appliance overview.....	12
3.2	Appliance data.....	14
3.3	Connection data.....	15
3.4	Installation location requirements .....	19
3.5	Minimum distances for operation and maintenance work.....	20
3.6	Minimum distances to other appliances.....	21
<b>4</b>	<b>Transporting the appliance .....</b>	<b>22</b>
4.1	Transporting the appliance with a lifting truck .....	22
4.2	Unpacking the appliance.....	22
<b>5</b>	<b>Positioning the appliance.....</b>	<b>23</b>
<b>6</b>	<b>Connecting the appliance.....</b>	<b>25</b>
6.1	Water connection.....	25
6.2	Waste water connection.....	30

---

## About this document

---

6.3	Electrical connection .....	31
6.4	Exhaust air system (for gas appliances) .....	34
6.5	Gas connection (for gas appliances) .....	36
<b>7</b>	<b>Initial start-up .....</b>	<b>38</b>
<b>8</b>	<b>Dimension drawings .....</b>	<b>40</b>
8.1	Dimension drawing: Size 6-11 and 10-11, electric .....	40
8.2	Dimension drawing: Size 6-11 and 10-11, gas.....	41
8.3	Dimension drawing: Size 12-21 and 20-21, electric .....	42
8.4	Dimension drawing: Size 12-21 and 20-21, gas.....	43
8.5	Dimension drawing: Size 20-11, electric.....	44
8.6	Dimension drawing: Size 20-11, gas .....	45

# 1 About this document





## 1.1 Content and target audience

These installation instructions describe how to transport, position and install the appliance safely. The installation instructions are directed to people who will transport, position and install the appliance.

## 1.2 Handling this document

- Keep these installation instructions accessible for installation staff.
- Keep these installation instructions throughout the appliance's entire life cycle.
- Pass these installation instructions on to subsequent owners.
- These installation instructions include a wiring diagram of the appliance. The wiring diagram is supplied with the appliance. The wiring diagram can be found in the installation area of table top units and in the control panel of floor-mounted appliances. Make sure that the wiring diagram is kept in the installation area or in the control panel.

## 1.3 Symbols used and layout of warnings

Symbol	Explanation
	Warning: a warning follows this symbol.
1.	Multi-step instruction: multiple instructions must be followed in the given order.
2.	
	Single-step instruction: exactly one instruction must be followed.
	List of several single-step instructions: instructions can be followed in any order.
	

Tab. 1: *Explanation of the symbols used*



### **DANGER!**

#### **Type and source of the danger!**

Consequence: non-compliance will result in death.

- ▶ Action to avoid the danger.



### **WARNING!**

#### **Type and source of the danger!**

Consequence: non-compliance will result in serious injury.

- ▶ Action to avoid the danger.



### **CAUTION!**

#### **Type and source of the danger!**

Consequence: non-compliance will result in minor injury.

- ▶ Action to avoid the danger.

### **NOTE!**

#### **Type and source of the danger!**

Consequence: non-compliance will result in material damage.

- ▶ Action to avoid the danger.



### **Information**

- ▶ Technical note or tip on operation.

## **1.4 Use of images**

Images are provided as examples only and may differ from the appliance supplied.

## **1.5 Warranty and disclaimer of liability**

You will find information on liability for material defects and warranty conditions in our general terms and conditions of business (T&C).

## 1.6 Models

The models are labelled with the number and type of levels.

Example: 6-11 means 6 levels of type GN 1/1.

## 2 Safety

### 2.1 Qualifications of installation staff

- ▶ This appliance must be installed by an Eloma service partner.
- ▶ Make sure that this appliance is only installed and started up by persons who have read these entire installation instructions and the entire operating instructions carefully and have understood the safety information.
- ▶ Make sure that the appliance is only connected to the water supply by approved and authorised skilled staff.
- ▶ Make sure that the appliance is connected to the power supply only by a qualified electrician: Comply with locally applicable regulations, VDE regulations and the regulations of the power supply company. In the USA and Canada: Comply with locally applicable regulations and valid local codes with the National Electrical Code ANSI / NFPA 70 or the Canadian Electrical Code CSA C22.2.
- ▶ Make sure that the appliance is only connected to the gas supply by the following skilled staff:
  - Skilled staff from the gas supply company
  - A competent officer provided by the manufacturer (certified by the DVGW, the German Technical and Scientific Association for Gas and Water)
  - Skilled staff from the contracted installation company registered with the gas supply company
  - Skilled staff from an agency authorised by a liquid gas bulk distributor

### 2.2 Safety information

#### 2.2.1 Improper installation

##### Risk of injury from improper installation

- ▶ Only perform the installation in accordance with these installation instructions.
- ▶ Do not modify the appliance.
- ▶ Do not open the housing.

---

## 2.2.2 Transport

### **Risk of injury and material damage from improper transport**

- ▶ Do not stack the appliance on a pallet.
- ▶ Secure the appliance against falling down on a pallet.

### **Risk of tipping and uncontrolled movements of appliances on castors due to uneven floors**

- ▶ Only transport the appliance on an even floor (max. 10° inclination).
- ▶ Move the appliance carefully.
- ▶ When the appliance is in the resting position, secure its castors with the immobilisation brake.

## 2.2.3 Positioning

### **Risk of injury and material damage from improper positioning**

- ▶ The appliance must be positioned by at least two persons.
- ▶ Only position floor models on level ground.
- ▶ Only stack appliances that are intended for stacking.
- ▶ With appliances intended for stacking:
  - Only stack two appliances
  - Secure the appliance against falling down

## 2.2.4 Gas connection and exhaust gas equipment

### **Risk of explosion from improper gas connection**

- ▶ Make sure that only suitably qualified experts connect the appliance to the gas supply.
- ▶ Comply with the locally applicable regulations of the professional association and gas supply company.
- ▶ Switch off the appliance before connecting to the gas supply.
- ▶ Observe the data on the type plate.
- ▶ Check that the gas system is tight.
- ▶ Route lines (particularly for appliances on castors) such that they cannot become damaged.
- ▶ If there is a smell of gas, observe the rules of what to do in the event of a gas leak (see section 2.3).

### **Risk of poisoning and suffocation from improper dissipation of exhaust gas**

- ▶ Install the exhaust gas system in accordance with legal specifications.
- ▶ Perform an exhaust gas test.

### **Risk of fire from hot exhaust gas pipe**

- ▶ Make sure that connecting cables cannot touch the gas exhaust pipe or the flow safeguard.
- ▶ Make sure that the gas exhaust pipe does not touch the flow safeguard.

## **2.2.5 Electrical connection**

### **Electric shock from live parts**

- ▶ Make sure that only suitably qualified experts connect the appliance to the electrical supply.
- ▶ Observe the data on the appliance type plate.
- ▶ Replace any damaged electrical cables immediately. Do not connect any appliances with damaged electrical cables.
- ▶ Route lines (particularly for appliances on castors) such that they cannot become damaged.
- ▶ Do not connect the appliance if you suspect it is damaged inside.

## **2.2.6 Water connection**

### **Water damage from improper installation of the water connection**

- ▶ Make sure that only suitably qualified experts connect the appliance to the water supply.
- ▶ Observe the data on the appliance type plate.
- ▶ Route lines (particularly for appliances on castors) such that they cannot become damaged.
- ▶ Do not connect the appliance if you suspect it is damaged inside.
- ▶ Install a non-return valve conforming to DIN EN 13959, Type EA in the on-site drinking water installation upstream of the appliance.

**2.3 What to do in the event of a gas leak (with gas appliances)**

1. Shut off the gas supply on site.
2. Do not touch any electrical switches.
3. Ventilate the room well.
4. Avoid creating naked flames or sparks.
5. Leave the room.
6. Contact the gas supply company.

### 3 Planning the installation

#### 3.1 Appliance overview

For appliances with door hinged on left: the connections are a mirror image of those shown here.

##### 3.1.1 Connections on floor models

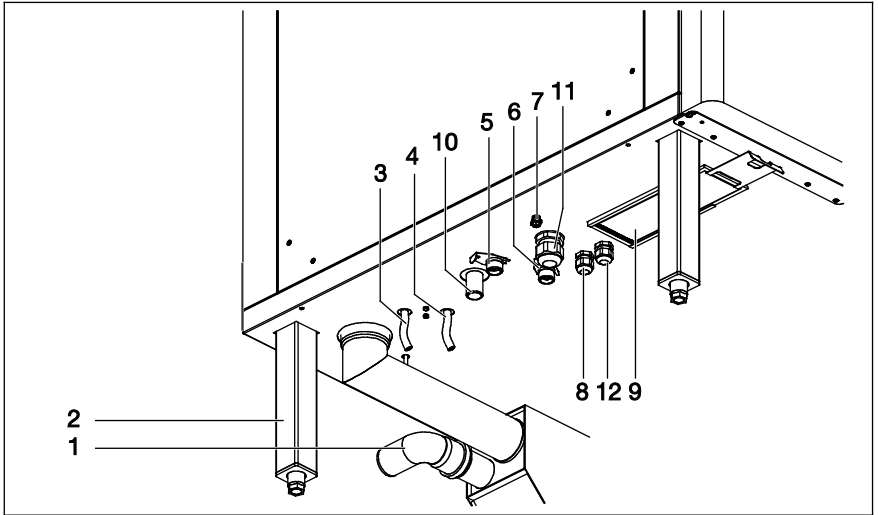

Fig. 1: Connections: size 12-21, 20-11 or 20-21, electric, gas

- 1 Connection for waste water line
- 2 Feet, adjustable
- 3 Connection for cleaning agent
- 4 Connection for rinse agent
- 5 Connection for soft water
- 6 Connection for hard water
- 7 Connection for potential equalisation
- 8 Connection for electrical cable (only for gas appliances)  
Floating contact (optional) (only for electrical appliances)
- 9 Air filter
- 10 Connection for gas line
- 11 Connection for electrical cable (only for electrical appliances)
- 12 Connection for energy optimiser (only for electrical appliances)

### 3.1.2 Connections on table top units

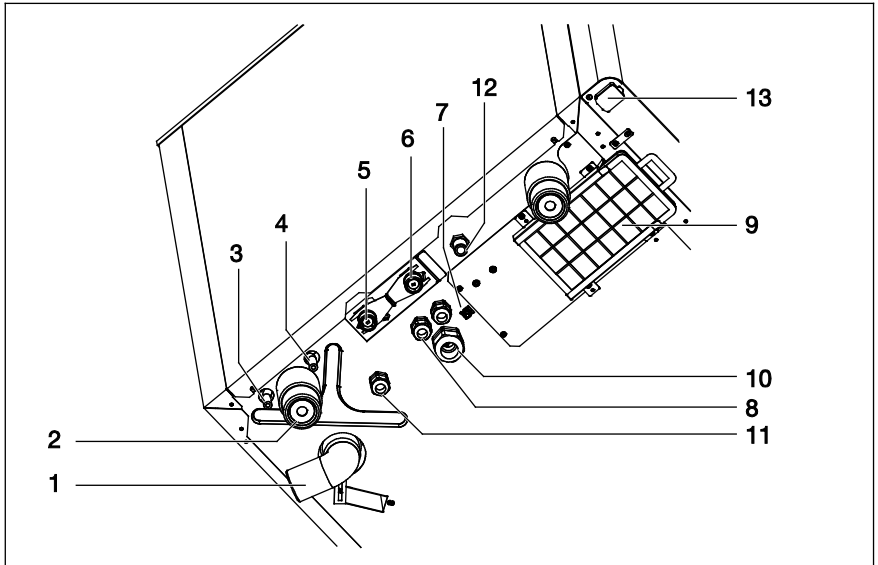



Fig. 2: Connections: size 6-11 or 10-11, electric, gas

- 1 Connection for waste water line
- 2 Feet, adjustable
- 3 Connection for cleaning agent
- 4 Connection for rinse agent
- 5 Connection for soft water
- 6 Connection for hard water
- 7 Connection for potential equalisation
- 8 Connection for electrical cable
- 9 Air filter
- 10 Connection for energy optimiser (only for electrical appliances)
- 11 Floating contact (optional) (only for electrical appliances)
- 12 Connection for gas pipe (only for gas appliances)
- 13 USB port

## Planning the installation

### 3.2 Appliance data

 Values in brackets apply to 1/1 appliances.

Appliance data		6-11	10-11	20-11	12-21	20-21
Housing		Stainless steel				
Appliance dimensions [mm (inch)]	Width	925 (36 3/8)	925 (36 3/8)	1030 (40 1/2)	1312 (51 5/8)	1312 (51 5/8)
	Depth	805 (31 5/8)	805 (31 5/8)	875 (34 1/2)	1088 (42 7/8)	1088 (42 7/8)
	Height	840 (33 1/8)	1120 (44 1/8)	1941 (76 3/8)	1495 (58 7/8)	1928 (75 7/8)
Number of levels		7 x GN1/1	11 x GN1/1	20 x GN1/1	12 (24) x GN2/1 (1/1)	20 (40) x GN2/1 (1/1)
Grid spacing [mm (inch)]		67 (2.6)				
Temperature in the chamber [°C (°F)]		30 – 300 (86 – 572)				
Weight [kg (lb)]	Electric	130 (286.6)	167 (368.2)	295 (650.4)	350 (771.6)	495 (1091.3)
	Gas	140 (308.6)	177 (390.2)	320 (705.5)	365 (804.7)	530 (1168.4)
Packaging weight [kg (lb)]		31 (68.3)	35 (77.2)	133 (293.2)	101 (222.7)	107 (235.9)
Noise level [db (A)]		<70				
Permissible ambient temperature [°C (°F)]		+4 (+39)				

Tab. 2: Appliance data

### 3.3 Connection data

#### 3.3.1 Water connection

Water connection	6-11	10-11	20-11	12-21	20-21
Water type	Drinking water				
Water connection	2 x G $\frac{3}{4}$ A				
Connection type	$\frac{1}{2}$ " hose with $\frac{3}{4}$ " screw union and flat packing (flexible, pressure-resistant, tested by the DVGW and approved in accordance with EN 61770)				
Connection pressure [bar]/ [kP (PSI)]	2 – 6/200 – 600 (29.0 – 87.0)				
Flow rate (dependent on pressure)					
Soft water [l/h (oz/h)]	16 (541.0)	19 (642.5)	20 (676.3)	25 (845.4)	25 (845.4)
Hard water [l/h (oz/h)]	55 (1859.8)	55 (1859.8)	65 (2197.9)	55 (1859.8)	65 (2197.9)

Tab. 3: Water connection

-  The specified values for hard water are dependent on pressure and correspond to a pressure of 4 bar / 400 kPa.

## Planning the installation



---

### 3.3.2 Waster water connection

Waste water connection	Value
Waste water line	
Minimum diameter [mm (inch)]	50 (1.97)
Maximum length [m (yd)]	1 (1.1)
Material	HT pipe PA-I 1818 DIN 16560
Waste water	
Maximum temperature [°C (°F)]	80 (176)

Tab. 4: Waste water connection

### 3.3.3 Electrical connection

-  Values in brackets apply for reduced heating power.
-  Applicable for all electrical connections: Use residual current operated circuit breaker.
-  In view of the components in the device (transformers, capacitors, etc.), we recommend a miniature circuit-breaker with cut-out characteristic D for connecting the appliance.

Electrical connection for electrical appliances	6-11	10-11	20-11	12-21	20-21
<b>3 AC 200 V</b>					
Connected load [kW]	9	17	35	20	40
Electrical protection [A]	3x32	3x63	3x125	3x63	3x125
<b>3 AC 230 V</b>					
Connected load [kW]	12	22	45	26	52
Electrical protection [A]	3x32	3x63	3x125	3x80	3x160
<b>3 AC 400 V/3 NAC 400 V</b>					
Connected load [kW]	12	17	45 (35)	34 (26)	68 (52)
Electrical protection [A]	3x20	3x32	3x80 (3x63)	3x63 (3x50)	3x100 (3x75)
<b>3 AC 208 V</b>					
Connected load [kW]	9.25	18.32	36.55	21.52	42.75
Electrical protection [A]	3x32	3x63	3x125	3x63	3x125
<b>3 AC 480 V</b>					
Connected load [kW]	9.5	18.5	36.5	21.5	43
Electrical protection [A]	3x16	3x32	3x50	3x32	3x63
Dissipation of heat, latent	3.960	6.120	16.200 (12.240)	12.240 (9.360)	24.480 (18.720)
Dissipation of heat, sensitive	2.772	4.284	11.340 (8.568)	8.568 (6.552)	17.136 (13.104)

Tab. 5: Electrical connection for electrical appliances

## Planning the installation

Electrical connection for gas appliances	6-11	10-11	20-11	12-21	20-21
<b>1 NAC 230 V</b>					
Connected load [kW]	12	20	40	35	70
Connected load, electrical [kW]	1.0	1.0	1.92	1.44	2.4
Electrical protection [A]	1x16	1x16	1x16	1x16	1x16
<b>1 NAC 110 V</b>					
Connected load [kW]	12	20	40	35	70
Connected load, electrical [kW]	1.0	1.0	1.92	1.44	2.4
Electrical protection [A]	1x16	1x16	1x20	1x16	1x25
Dissipation of heat, latent	4.320	7.200	14.200	12.600	25.200
Dissipation of heat, sensitive	3.672	6.120	12.240	10.710	21.420
Prescribed minimum connection cross-section [mm <sup>2</sup> ]	3x1.5				

Tab. 6: *Electrical connection for gas appliances*

### 3.3.4 Gas connection for gas appliances

Gas connection			6-11	10-11	20-11	12-21	20-21	
Connected load [kW]			12	20	40	35	70	
Gas connection [in]			1/2	1/2	3/4	3/4	3/4	
Gas type	Connection pressure		Heating value [MJ/m <sup>3</sup> (Btu/ft <sup>3</sup> )]	Maximum gas consumption at rated thermal load [m <sup>3</sup> /h]/[kg/h]				
	[mbar]	[kPa]						
Natural gas E(H)	18 – 25	1.8 – 2.5	34 (912.5)	1.3	2.1	4.2	3.5	7.0
Natural gas L	20 – 30	2.0 – 3.0	29 (778.3)	1.4	2.5	4.9	4.1	8.2
Propane	25 – 57	2.5 – 5.7	88 (2361.8)	0.47/ 0.85	0.82/ 1.6	1.6/ 3.2	1.4/ 2.7	2.7/ 5.3
Butane	25 – 57	2.5 – 5.7	116 (3113.3)	0.37/ 0.86	0.62/ 1.6	1.2/ 3.3	1.0/ 2.7	2.0/ 5.4

Tab. 7: Gas connection for gas appliances

### 3.4 Installation location requirements

- Ambient temperatures: >4 °C (>39 °F)
- Free of toxic or explosive gases or substances
- If the appliance is to be operated outdoors: protected from rain, thunderstorms, lightning strikes and wind
- If a gas appliance is being used with liquid gas: above ground level
- We recommend positioning the appliance underneath an extraction hood.

## Planning the installation

### 3.5 Minimum distances for operation and maintenance work

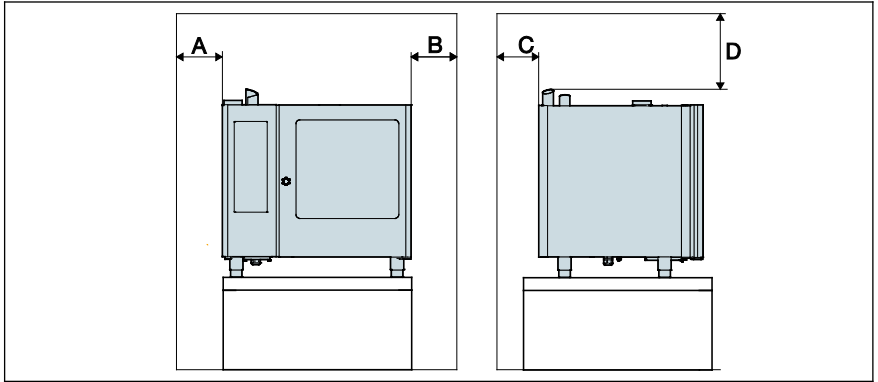

Fig. 3: Minimum distances for table top units and floor models

Item	Spacing [mm (inch)]	Table top unit	Floor model unit
<b>A</b>	Side with Control Panel to wall		
	Minimum distance	>50 (1.97)	>50 (1.97)
	Clearance for maintenance work (recommended)	–	>500 (19.7)
	Clearance for mobile tray rack (recommended)	–	800 (31.5)
<b>B</b>	Side opposite Control Panel to wall		
	Minimum distance	>50 (1.97)	>50 (1.97)
	Clearance for mobile tray rack (recommended)	–	800 (31.5)
<b>C</b>	Rear of appliance to wall		
	Minimum distance	>50 (1.97)	>50 (1.97)
<b>D</b>	Top edge of appliance to ceiling		
	Extraction hood provided on site	>50 (1.97)	>50 (1.97)
	No extraction hood provided on site	>1000 (39.4)	>1000 (39.4)

Tab. 8: Minimum distances for table top units and floor models

### 3.6 Minimum distances to other appliances

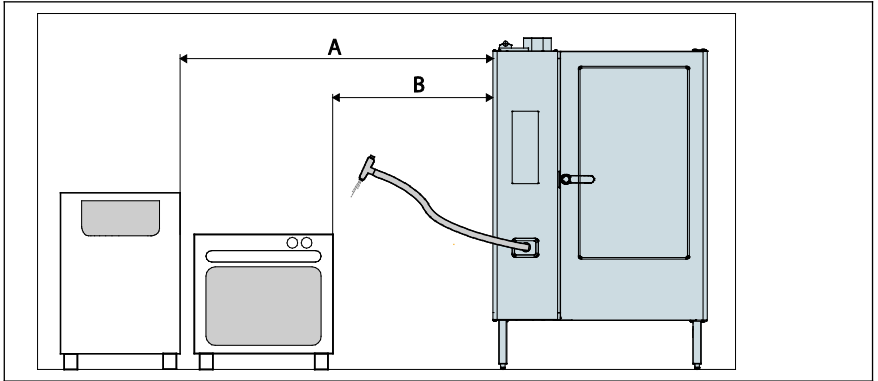

Fig. 4: Minimum distances to other appliances

Item	Spacing [mm (inch)]	Table top unit	Floor model
A	Appliance to sources of heat or moisture (e.g. baking oven)	>500 (19.7)	> radius of action of the hand shower
B	Appliance to deep fat fryer		

Tab. 9: Minimum distances to other appliances

### 4 Transporting the appliance

#### 4.1 Transporting the appliance with a lifting truck

- ▶ Use a lifting truck to transport, lift and lower the appliance.
- ▶ Only transport the appliance on a pallet.
- ▶ Observe the required clearance height and width.

#### 4.2 Unpacking the appliance

1. Take all boxes, packaging material, accessories and documents out of the chamber.
2. Dispose of packaging in accordance with local regulations.
3. Remove the protective film from the sides, rear and top.
4. Remove residue with a glass cleaner.
5. Check the appliance for damage. If the appliance is damaged:
  - Do not install the appliance.
  - Contact your Eloma service partner.

## 5 Positioning the appliance



### **WARNING!**

#### **Injury from uncontrolled movements of the appliance!**

Crushing under the appliance feet

- ▶ The appliance must be lifted from the pallet by at least two persons.
- ▶ Pay attention to fingers when setting the appliance down.



Gas appliances must not be used as mobile devices.

- ▶ Do not install gas appliances on moving surfaces (e.g. on castors)
1. Observe local and general rules relating to kitchen equipment.
  2. If the appliance is installed in the vicinity of materials that are sensitive to heat or at risk of catching fire, observe the relevant fire protection regulations.
  3. Ensure that the installation location requirements are met (see section 3.4).
  4. Ensure that the minimum distances are complied with (see section 3.5, see section 3.6).
  5. Secure the appliance against tilting, falling down and becoming displaced.
  6. Remove the transportation locking device from the chamber.
  7. Remove the protective cap from the core probe.
  8. Check the appliance for external damage. Do not connect the appliance if you suspect it is damaged inside.
  9. Make sure that the air baffle is locked in place.
  10. Make sure that the fat filter and drain filter are secure.
  11. Make sure there are no combustible materials above the appliance.
  12. Make sure that the supply air opening and the ventilation slots are unobstructed and not covered.
  13. Keep the area between the appliance feet unobstructed to ensure sufficient ventilation below the appliance.
  14. For table top units: make sure that the installation position can bear the weight of the appliance (see section 3.2).
-

## Positioning the appliance

---

**i** We recommend placing table top units on support stands, cabinets or thermal cabinets.

15. For appliances on castors: secure the castors with the foot brake.
16. For appliances with appliance feet: position the appliance so it is level. If necessary, use the height-adjustable appliance feet to compensate for any minor unevenness.
17. For floor models:
  - Adjust the appliance so a distance of  $15 \pm 5$  mm ( $0.59 \pm 0.2$  in) is maintained between the mobile tray rack and the top edge of the chamber floor.
  - Adjust the appliance so the mobile tray rack (2) is not in contact with the door seal (1).

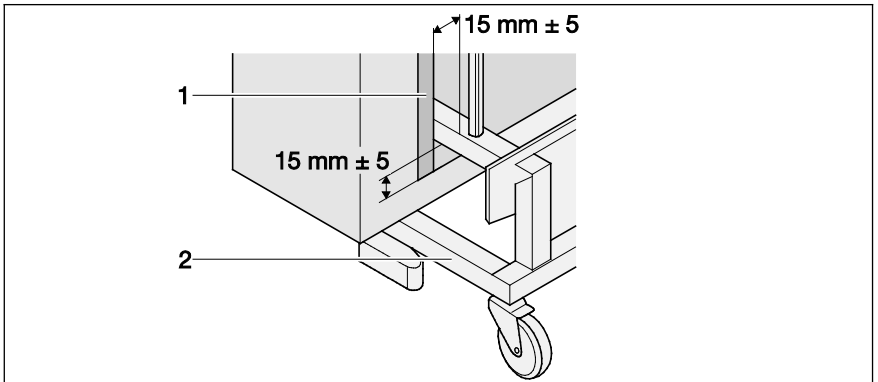

*Fig. 5: For floor models: distance between door seal and mobile tray rack*

- 1 Door seal
- 2 Mobile tray rack

## 6 Connecting the appliance

### 6.1 Water connection

#### 6.1.1 Limit values

Parameter	Limit value
Total hardness	$\leq 3^\circ$ dH
pH value	7.0 – 8.5
Conductivity	$\leq 90$ $\mu$ S/cm
Cl <sup>-</sup>	<60 mg/l
SO <sub>4</sub>	<100 mg/l
SiO <sub>4</sub>	<10 mg/l
Fe	<0.05 mg/l
Mn	<0.05 mg/l
Cu	<0.05 mg/l
Cl <sub>2</sub>	<0.1 mg/l

Tab. 10: Water limit values

## Connecting the appliance

---

### 6.1.2 Water connection versions

**Water connection for raw water from the mains supply, with a water softening unit**

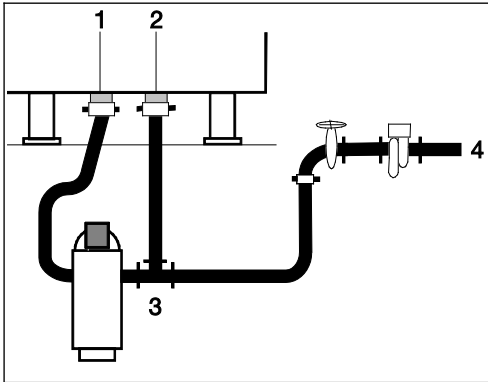

- 1 Soft water connection
- 2 Hard water connection
- 3 Water softening unit
- 4 Water connection

**Water connection for soft water and raw water**

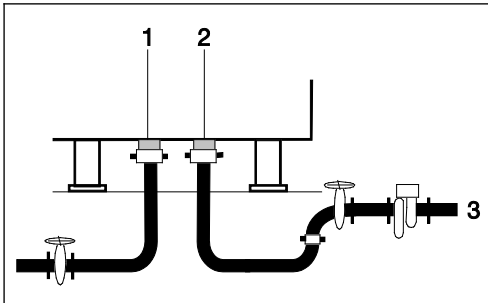

- 1 Soft water connection
- 2 Hard water connection
- 3 Water connection

**Water connection for osmosis from the mains supply**

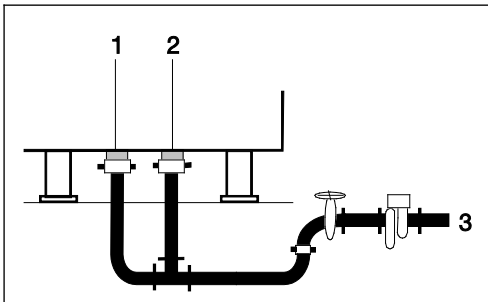

- 1 Soft water connection
- 2 Hard water connection
- 3 Water connection

### 6.1.3 Installing the soft water connection and hard water connection

**NOTE!**

**Material damage from improper water connection!**

Water damage

- ▶ Make sure that the appliance is only connected to the water supply by approved and authorised skilled staff.
- ▶ Observe the connection labels on the appliance.

**NOTE!**

**Material damage from installing the wrong water treatment systems!**

Damage to glass pane, chamber and parts of the appliance

- ▶ Do not install a sodium ion exchanger.
- ▶ Do not install any systems that use silicate dosing.
- ▶ Do not install any systems based on electromagnetic fields.



The soft water connection and hard water connection are labelled on the appliance.

- ▶ Check the water quality and water hardness with your local water supply company.
- ▶ Observe the connection labels on the appliance.
- ▶ If the water contains impurities such as sand, iron particles or suspended particles: install a 5 – 15 µm fine filter (e.g. activated carbon filter) for the soft and hard water connections.

## Connecting the appliance

---

- ▶ If limit values are exceeded, perform the following actions:

Limit value exceeded	Action
Total hardness >3 °dH	▶ Install a hydrogen ion exchanger for the soft water connection.
Cl <sub>2</sub> >0.1 mg/l	▶ Install an activated carbon filter for the soft and hard water connections.
Cl <sup>-</sup> >60 mg/l and SiO <sub>4</sub> ≥ 10 mg/l	▶ Install a reverse osmosis system for the soft and hard water connections. ▶ Make sure that a residual hardness with a conductivity of 10 µS/cm is maintained.

*Tab. 11: Actions to take if limit values are exceeded*

- ① Reverse osmosis systems are an alternative to full and partial demineralisation via filter systems. A reverse osmosis system removes water-hardening substances and non-hardening minerals from water.

### 6.1.4 Prescribed cleaning and rinse agents

The following cleaning and rinse agents are approved for cleaning the chamber:

- Eloma multi-clean special cleaner
- Eloma multi-clean rinse aid

### 6.1.5 Installing the autoclean connection



#### **WARNING!**

##### **Risk of chemical burns from cleaning agents!**

Chemical burns to the skin and eyes

- ▶ Wear protective clothing (e.g. long-sleeved clothing, protective gloves and glasses).
- ▶ Observe the safety information for the prescribed cleaning and rinse agents (see section 6.1.4).

#### **NOTE!**

##### **Material damage from mixing up cleaning and rinse agents!**

- ▶ Observe the connection labels on the appliance.
- ▶ Attach the cleaning agent to the red canister connection.
- ▶ Attach the rinse agent to the blue canister connection.

#### **NOTE!**

##### **Material damage from incorrect cleaning or rinse agent!**

- ▶ Only use the prescribed cleaning and rinse agents (see section 6.1.4).



The connections for the cleaning and rinse agents are labelled on the appliance.

1. Determine the installation location of the canisters:
  - For floor models: position the canisters on the floor:
  - For table top units: position the canisters below the bottom edge of the appliance.
  - Maximum delivery head: 1.5 m (1.64 yd)
  - Maximum delivery distance: 10 m (10.9 yd)
2. Observe the connection labels on the appliance:
  - Attach the cleaning agent to the red canister connection.
  - Attach the rinse agent to the blue canister connection.

## Connecting the appliance

---

### 6.2 Waste water connection

#### 6.2.1 Waste water connection versions

##### Fixed connection

Application: any, as the appliance is intrinsically safe as per the regulations of the DVGW.

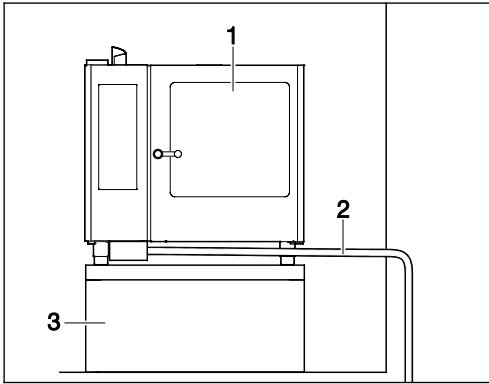

- 1 Appliance
- 2 Fixed connection
- 3 Cabinet

##### Fixed connection with air exhaust pipe

Application: when an external siphon is present.

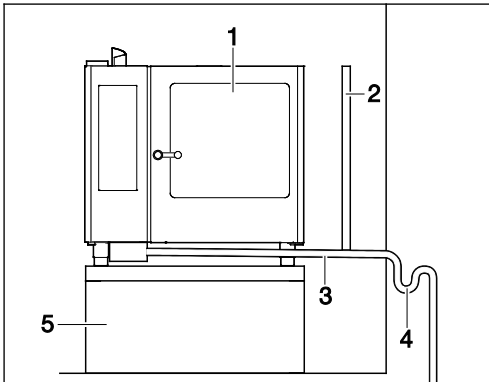

- 1 Appliance
- 2 Air exhaust pipe
- 3 Fixed connection
- 4 Siphon
- 5 Cabinet

### Waste water drain into vent tundish

Application: when an external siphon is present or the diameter of the external waste water pipe is too small.

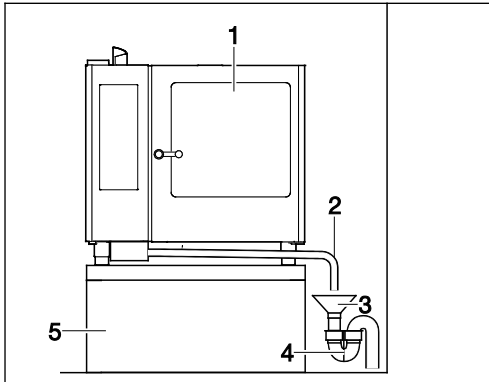

- 1 Appliance
- 2 Waste water pipe
- 3 Vent tundish
- 4 Siphon
- 5 Cabinet

#### 6.2.2 Installing the waste water connection

1. Observe the local waste water regulations.
2. Determine the connection version (see section 6.2.1).
3. Install the waste water pipe such that the slope is at least 5%.
4. Add three litres of water (101.4 oz) to the chamber to fill the siphon.

### 6.3 Electrical connection



#### **DANGER!**

#### **Electric shock from improper installation!**

- ▶ Make sure that the appliance is connected to the power supply only by a qualified electrician:
- ▶ Comply with locally applicable regulations, VDE regulations and the regulations of the power supply company.
- ▶ Incorporate the appliance into the equipotential bonding system.



### **DANGER!**

#### **Electric shock from damaged cables!**

- ▶ Replace any damaged electrical cables immediately. Do not connect any appliances with damaged electrical cables.
- ▶ Route cables such that they are protected against becoming damaged during operation.

### **6.3.1 Installing the electrical connection**



The appliance must be connected via a fixed connection.

- ▶ Observe the data on the type plate.
- ▶ Establish the fixed connection:
  - Connect the power cable to the terminals securely.
  - Make sure that the phases are connected correctly.
- ▶ Customer to provide and install an all-pole electric disconnecting device upstream of the appliance. This device must comply with the applicable regulations and standards and provide complete disconnection under category III overvoltage.
- ▶ If a connecting cable is not included in the scope of supply, use a cable which meets the relevant applicable regulations and standards and the following specifications:
  - Mains connecting cables must be oil-resistant, sheathed, flexible cables. They must not be lighter than a standard polychloroprene or other equivalent synthetic elastomer-sheathed cable that is identified as compliant with 60245 IEC 57.

- The following cable cross-sections must be observed:

Rated current of the appliance [A]	Nominal cross-section [mm <sup>2</sup> ]
≤ 0.2	Tinsel conductor cable <sup>a</sup>
> 0.2 and ≤ 3	0.5 <sup>a</sup>
> 3 and ≤ 6	0.75
> 6 and ≤ 10	1.0 (0.75) <sup>b</sup>
> 10 and ≤ 16	1.5 (1.0) <sup>b</sup>
> 16 and ≤ 25	2.5
> 25 and ≤ 32	4
> 32 and ≤ 40	6
> 40 and ≤ 63	10

NOTE: For mains connecting cables of polyphase appliances, the nominal conductor cross-section is based on the largest conductor cross-section for each phase at the point where the mains connecting cable is connected to the appliance terminals.

<sup>a</sup> These cables may only be used provided that the length of the cable between the point at which the cable or bend protection grommet enters the appliance and the entry to the plug is no more than 2 m.

<sup>b</sup> Cables with the cross-sectional values specified in brackets may be used for portable appliances provided that they are no more than 2 m long.

Tab. 12: Minimum conductor cross-section

- ▶ Install a residual-current-operated circuit-breaker on site in accordance with the relevant applicable regulations. We recommend a type B residual-current-operated circuit-breaker with a tripping current of 30 mA.
- ▶ For appliances with the energy optimiser system: connect the appliance to an energy optimiser system (not included in the scope of supply).

## Connecting the appliance

---

### 6.3.2 Connecting potential equalisation

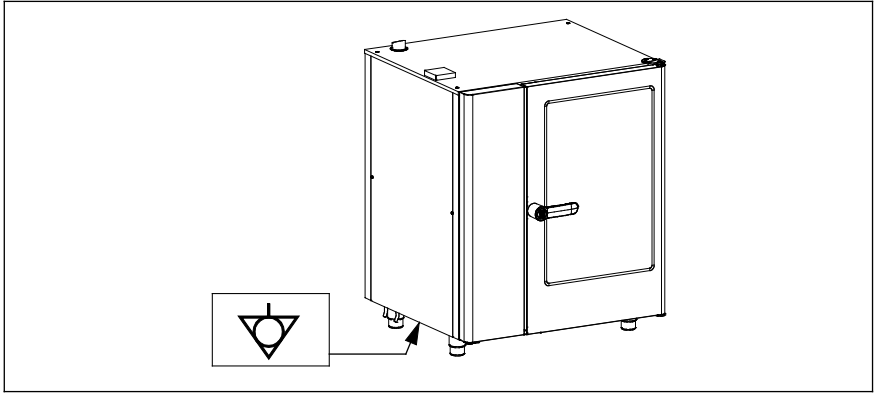

*Fig. 6: Connection label for equipotential bonding*

- ▶ Connect the equipotential bonding cable to the appliance (see section 3.1.1).

### 6.4 Exhaust air system (for gas appliances)

- ▶ Agree the design of the exhaust gas system with the responsible district chimney sweep.
- ▶ Place the design of the exhaust gas system on record.
- ▶ If exhaust air and exhaust gas are being discharged from type B gas appliances together, observe the relevant national/state building regulations.
- ▶ Type B gas appliance: gas appliance with exhaust gas system (B<sub>13</sub>, B<sub>23</sub> with fan upstream of the burner)

### 6.4.1 Positioning the appliance under a vapour extraction hood (B<sub>23</sub>)

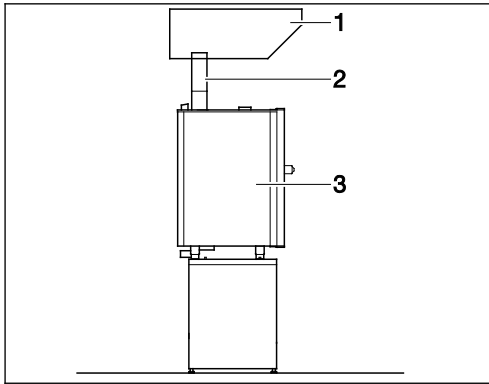

- 1 Vapour extraction hood
- 2 Exhaust gas pipe
- 3 Appliance

- ▶ Make sure that the vapour extraction hood meets the relevant specifications (DVGW work sheet G 634).
- ▶ Make sure that the vapour extraction hood is suitable for exhaust gas temperatures of 500 °C (932 °F).

**i** Type B<sub>23</sub> gas appliances do not require flow protection.

- ▶ Install a flame protection filter.
- ▶ Maintain a distance equivalent to 1.25 to 2 times the diameter of the exhaust gas pipe between the exhaust gas pipe and the flame protection filter.
- ▶ Install a safety device which ensures that gas can only be supplied to the burner when the vapour extraction hood is switched on.

### Connecting the appliance to the exhaust gas system (B<sub>13</sub>)

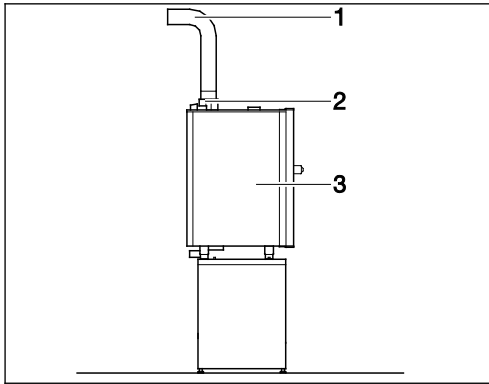

- 1 Exhaust gas pipe
- 2 Flow protection
- 3 Appliance

- ▶ Make sure that the house chimney meets the relevant specifications (DIN 18160, Part 1).
- ▶ Make sure that the exhaust gas system meets the relevant specifications (DVGW work sheet G 660).
- ▶ Install flow protection.
- ▶ Make sure that the pipes which come into contact with exhaust gases are resistant to heat.

## 6.5 Gas connection (for gas appliances)



### **DANGER!**

#### **Risk of explosion from incorrect gas connection!**

Serious burns on the skin

- ▶ Make sure that the appliance is only connected to the gas supply by the following skilled staff:
  - Skilled staff from the gas supply company
  - A competent officer provided by the manufacturer (certified by the DVGW, the German Technical and Scientific Association for Gas and Water)
  - Skilled staff from the contracted installation company registered with the gas supply company
  - Skilled staff from an agency authorised by a liquid gas bulk distributor

- ❗ It is not permitted to install third-party burners, individual parts and gas fittings, or those of different types.

### 6.5.1 Preparatory work

- ▶ Inform the responsible gas supply company.
- ▶ Observe the DVGW-TRGI Technical Rules for Gas Installations.
- ▶ Observe the data on the type plate. The gas type, gas pressure and power set must match the conditions at the installation location.
- ▶ Comply with the locally applicable regulations of the professional association and gas supply company.
- ▶ Observe the notice at the gas connection.

### 6.5.2 Installing the gas connection

#### Prerequisite

- The gas supply company has been informed.

#### NOTE!

#### Short circuit from leak spray on electrical cables!

- ▶ Only apply leak spray to the lines of the gas system.
1. Connect the gas lines to the appliance (see section 3.1.1).
  2. Route gas lines such that they are protected against mechanical movement and heat.
  3. Secure the appliance against becoming displaced.
  4. Use leak spray to check tightness.
  5. Perform an exhaust gas analysis in accordance with the start-up report.
  6. Document the exhaust gas values in the start-up report.
  7. In the event of deviating exhaust gas values: have an Eloma service partner adjust the burner settings.

### 7 Initial start-up

#### Prerequisite

- The appliance has been installed in accordance with the installation instructions.
- All foreign objects have been removed from the chamber.

#### NOTE!

#### Condensation forms due to the change in ambient temperature!

Damage to the control group

- ▶ On changing from a cold to a warm environment: only start up the appliance once it has reached room temperature (after around 2 hours).
1. Lock the mobile tray rack in place.
  2. Open the on-site water tap.
  3. Observe the instructions for use provided with the water treatment system and adjust it if necessary.
  4. Open the on-site gas tap.
  5. Switch on ventilation and air-conditioning systems.
  6. Switch on the appliance (see operating instructions).
  7. Start the cooking program with the following cooking settings:
    - Nominal temperature: 250 °C (482 °F)
    - Cooking time: 60 minutes
  8. For appliances with an autoclean program: start the "Start up" clean program (see operating instructions).

- ① Error message if no gas is supplied:
  - Internal gas valve is closed.
  - Buzzer sounds.
  - For appliances with a touch screen: symbol with a small flame appears.  
For appliances with a turning knob: "GrES" and "711" appear alternately on the "Step/program number" display.
  - ▶ For appliances with a touch screen: touch the symbol with a small flame to acknowledge errors and restart the gas system.  
For appliances with a turning knob: press the **Up/Down step/program number** buttons simultaneously for 3 seconds to unlock the appliance.
  
- ① The error message may appear multiple times if the gas lines are long.

## 8 Dimension drawings

The dimension drawings apply to appliances with doors hinged on the right. For appliances with door hinged on left: the dimension drawing is a mirror image of that shown here.

### 8.1 Dimension drawing: Size 6-11 and 10-11, electric

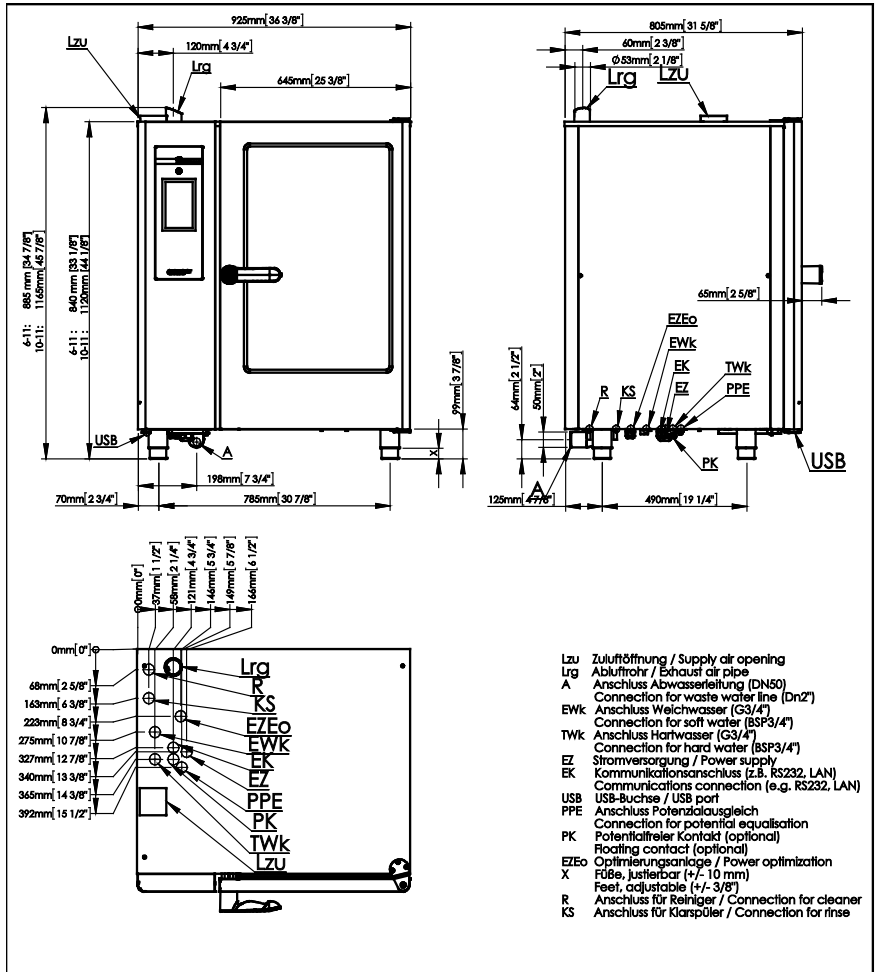

Fig. 7: Size 6-11 and 10-11, electric, right hinged

8.2 Dimension drawing: Size 6-11 and 10-11, gas

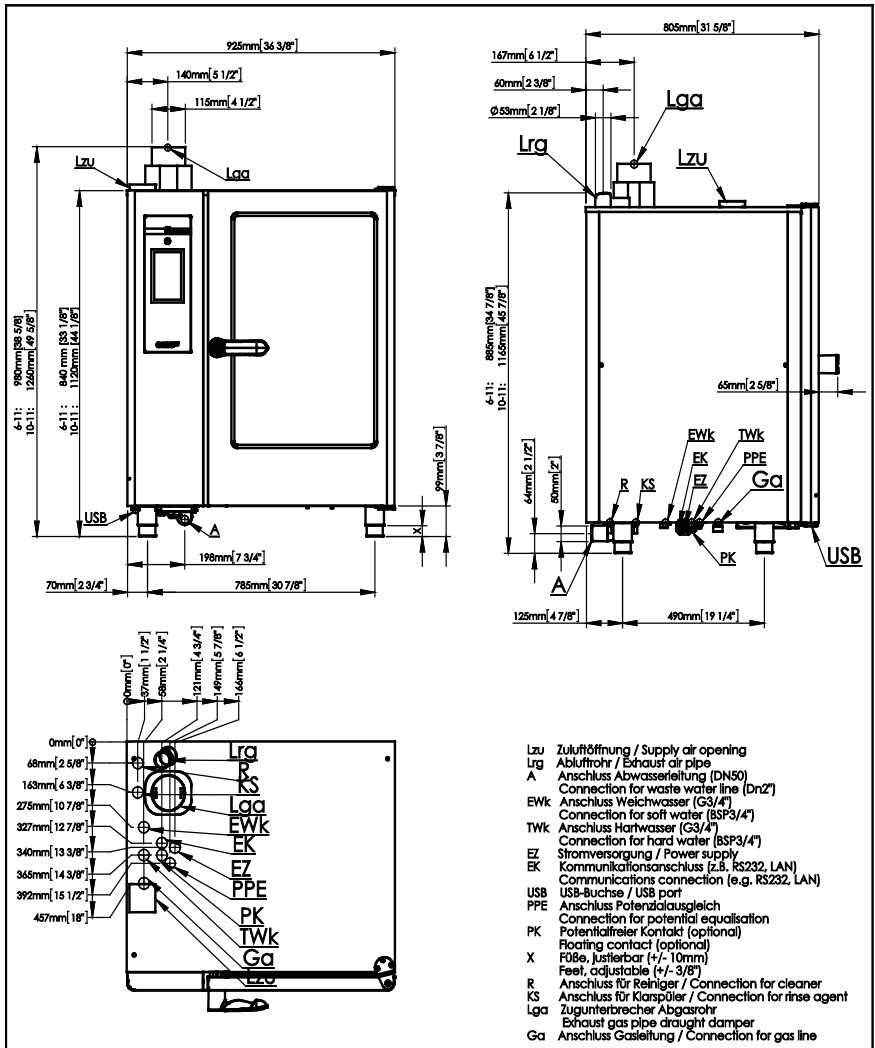

Fig. 8: Size 6-11 and 10-11, gas, right hinged

8.3 Dimension drawing: Size 12-21 and 20-21, electric

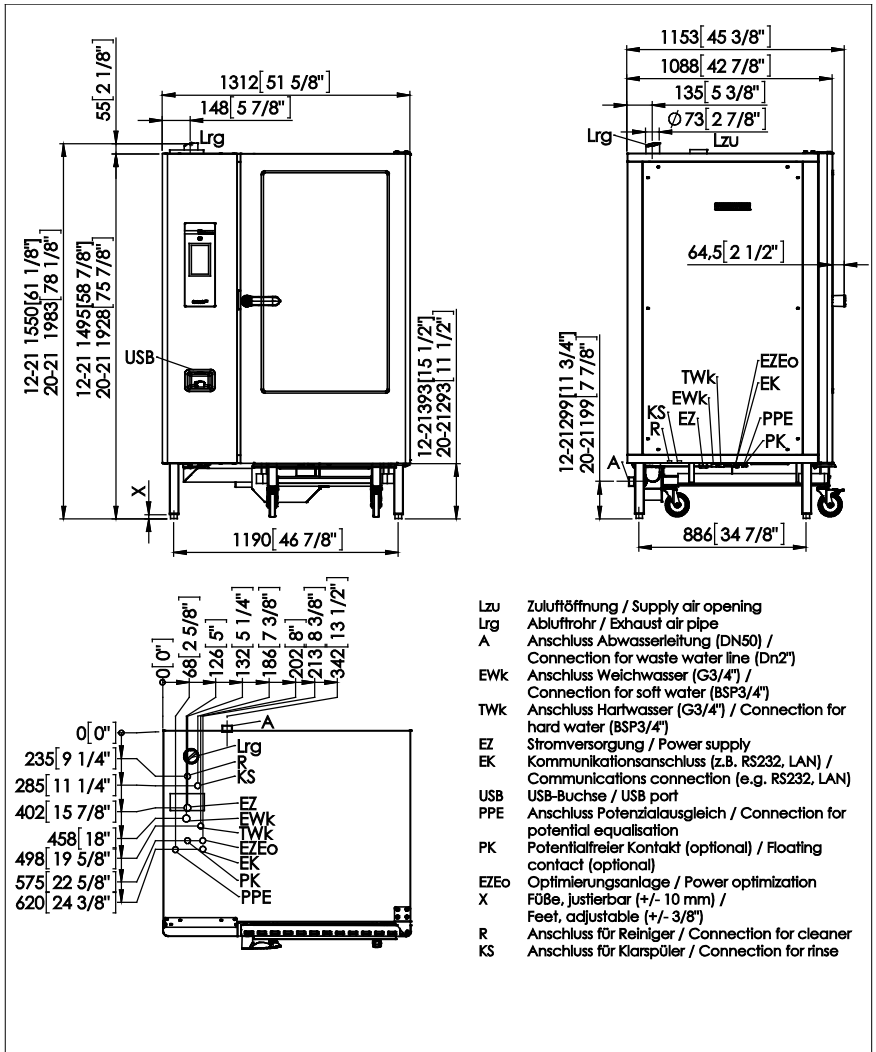

Fig. 9: Size 12-21 and 20-21, electric, right hinged

8.4 Dimension drawing: Size 12-21 and 20-21, gas

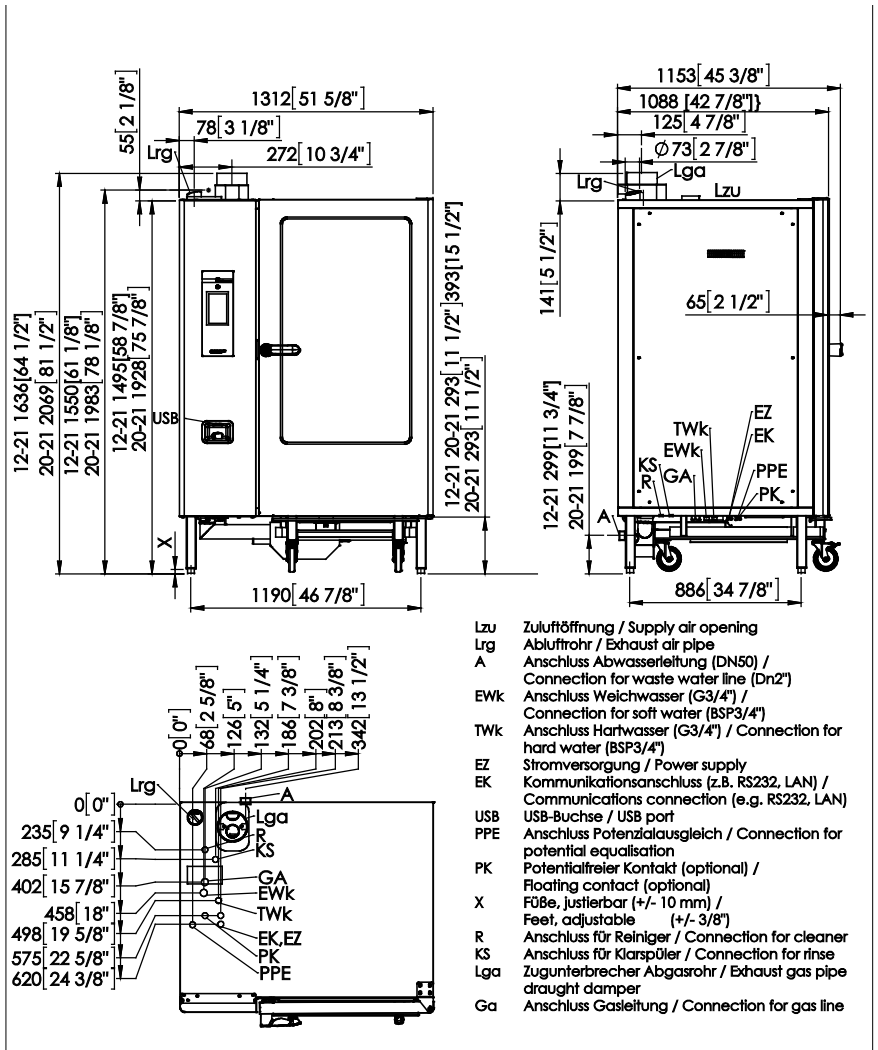

Fig. 10: Size 12-21 and 20-21, gas, right hinged

8.5 Dimension drawing: Size 20-11, electric

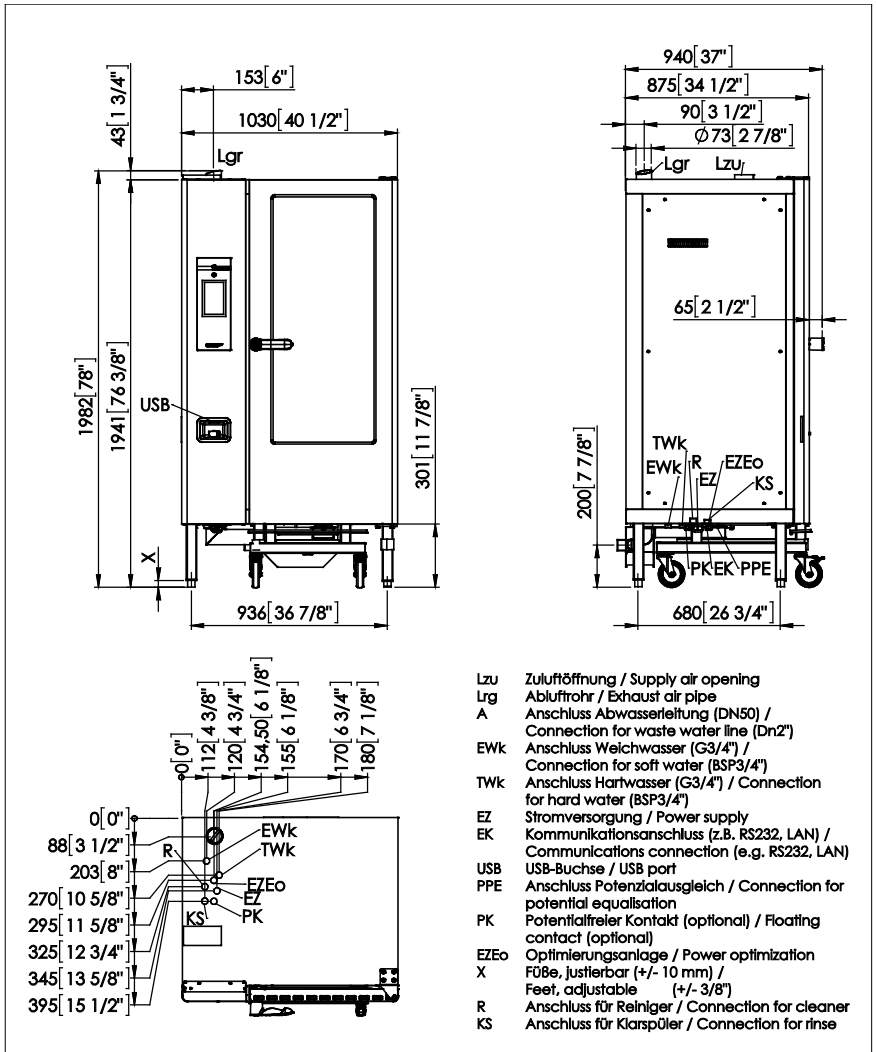

Fig. 11: Size 20-11, electric, right hinged

8.6 Dimension drawing: Size 20-11, gas

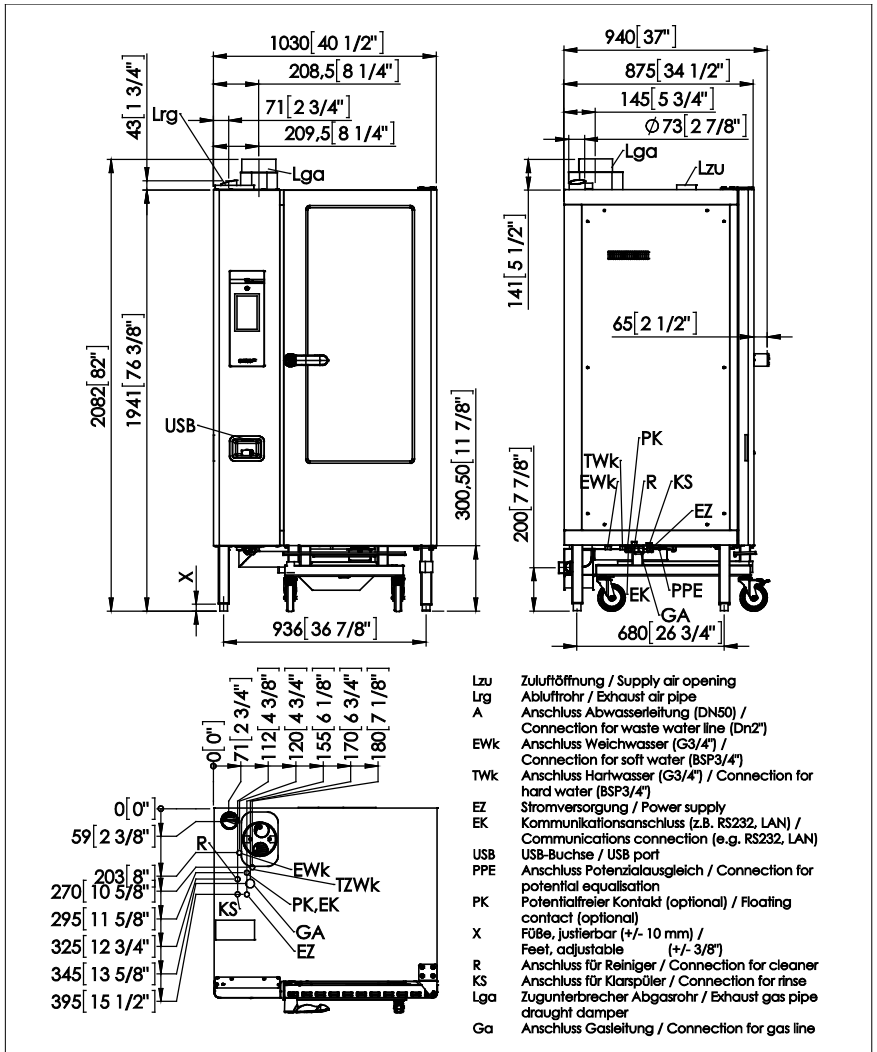

Fig. 12: Size 20-11, gas, right hinged





eloma

ins\_EL2000885\_ge\_m\_v03\_en | 06/2014