

# Installation and Maintenance Manual

**ELKAY®**

commercial products

## CARBONATION CHILLER

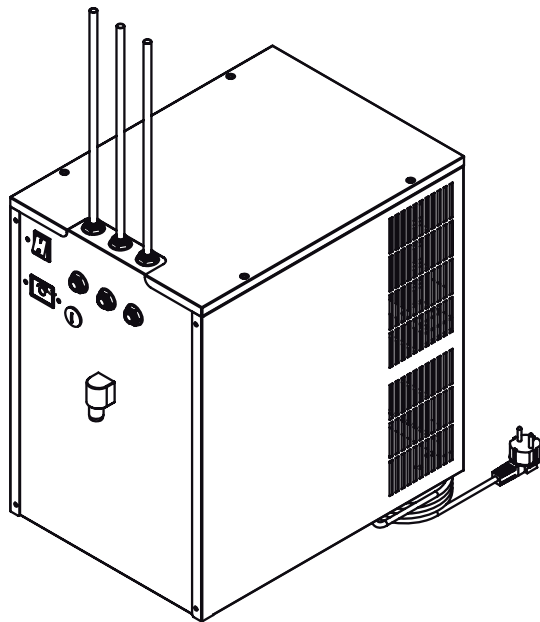

## FONTEMAGNA BRIDGE

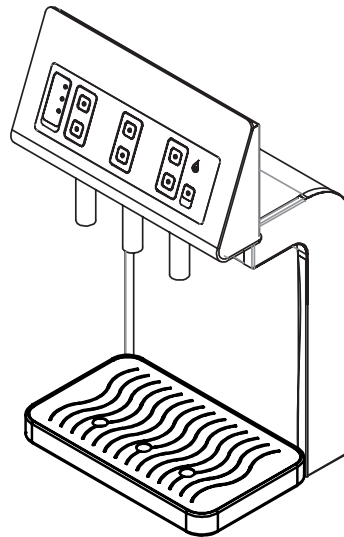

## COLUMN TAP

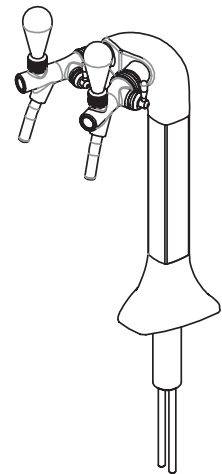

### Table of Contents

Declaration of Conformity Association	2	Before You Begin – Requirements for Installation	7	Installing the Water Cooler and the Supply head	11
Recommendations for Safeguarding the Environment	3	Mounting Dimensions	7	Operating the Touch Control Keypad <i>Fontemagna Bridge Only</i>	16
Explanation of Warning/Safety Icons	3	Operating Environment	8	Programming the Touch Control Keypad <i>Fontemagna Bridge Only</i>	18
Introduction	4	Water	8	Routine Maintenance	19
Components Guide	5	Electrical	8	Troubleshooting	22
Product Specifications	6	Tools You Will Need	9	Replacement Parts	25
		Unpacking the Kit	9		
		What's in the Kit	10		



**NOTICE:** Read the instructions in this manual and retain for future reference.

# Declaration of Conformity



## Materials compliant for contact with drinking water

This unit is intended for the dispensing of drinking water, and so the materials that enter into direct contact with water meet the criteria for food-grade components pursuant to the current legislation. In addition, the unit is manufactured in compliance with Italian Ministerial Decrees 174 of 04/06/2004 and 25 of 02/07/2012.

## Electrical safety

This water cooler is designed, manufactured and marketed in compliance with:

- the safety objectives of the Low Voltage Directive 2006/95/EC;
- the protection requirements of the Electromagnetic Compatibility Directive 2004/108/EC.

The electrical safety of the product is ensured only when it is properly connected to an efficient, legally compliant grounding circuit.

UL standard for safety of drinking water coolers, ANSI/UL 399, Issued: 2008/08/22, Ed: 7, Rev: 2013/10/18 and UL 60335-1

CSA standard for refrigeration equipment, CSA Column Tap2.2 No. 120, Issued: 2013/03/01, Ed: 4 and CAN/CSA Column Tap2.2 No. 60335-1

# Association



## International Awards

**2014 – BEST PROMOTION OF HEALTH AND HYDRATION**  
EUROPEAN AQUA AWARDS 2014, BUDAPEST

**2013 – BEST PRODUCT INNOVATION**  
EUROPEAN AQUA AWARDS 2013, BERLIN

**2012 – BEST ENVIRONMENTALLY FRIENDLY PRACTICE**  
EUROPEAN AQUA AWARDS 2012, ISTANBUL

**2011 – BEST PRODUCT DESIGN/INNOVATION**  
EUROPEAN AQUA AWARDS 2011, ODESSA

**2010 – BEST ENVIRONMENTALLY FRIENDLY PRACTICE**  
EUROPEAN AQUA AWARD 2010, PRAGUE

# Recommendations for Safeguarding the Environment

## Packaging materials



The packaging materials are 100% recyclable. Please follow the local guidelines on waste disposal. For safety reasons keep the packaging material out of the reach and sight of children.

## Scrappage



The Carbonation Chiller water cooler, Fontemagna Bridge and Column Tap supply head are made using recyclable material.

These units are marked in compliance with European Directive 2002/96/EC on Waste Electrical and Electronic Equipment (WEEE). By ensuring that the product is scrapped correctly, you will help to prevent potential negative consequences for the environment and for health. This symbol indicates that the product should not be treated as domestic waste but should be taken to a dedicated recycling center for electrical and electronic equipment. Immediately prior to scrapping, cut off the power cable.

For more information on the treatment, recovery and recycling of this product, please contact the appropriate local office, the waste disposal service or the reseller from which the product was purchased.

## Explanation of Warning/Safety Icons



**NOTICE:** Indicates an instruction which, if not followed, could result in damage to product or property or poor product performance.



**CAUTION:** Indicates an instruction which, if not followed, could result in minor or moderate injury.



**WARNING:** Indicates an instruction which, if not followed, could result in serious injury or death.

# Introduction

The Carbonation Chiller water cooler, Fontemagna Bridge and Column Tap supply head bring contemporary style and state-of-the-art technology to commercial water dispensers. Carbonation Chiller undercounter water cooler can be used with either Fontemagna Bridge or Column Tap, combining professional performances with a modern, sleek design.

- Multiple dispensing options: cold still water, cold sparkling water, and room-temperature still water
- Natural materials throughout: stainless steel, aluminum, glass
- Internal components made entirely of stainless steel

## Carbonation Chiller

- Cooling serpentine coil made with the best stainless steel for drinkable water - AISI 316
- High-insulation ice bank ensures a high output of cold water, still and sparkling

## Fontemagna Bridge

- Electronic keypad with glass cover, easy to use and hygienic, with touch control commands
- Preprogrammed quantities of water to minimize overflow and waste
- Energy Saving command: when selected, this feature enables standby functionality of the unit, with consumption reduced by 75% compared to full functionality
- Bactericidal UV lamp at exit of each tap

## Column Tap

- Self closing tap to avoid accidental water leakage
- Compensator included to regulate the flow of each spout



**NOTICE:** Due to rigorous testing, product may reasonably be expected to contain traces of sanitizing solution.

# Components Guide

## Carbonation Chiller

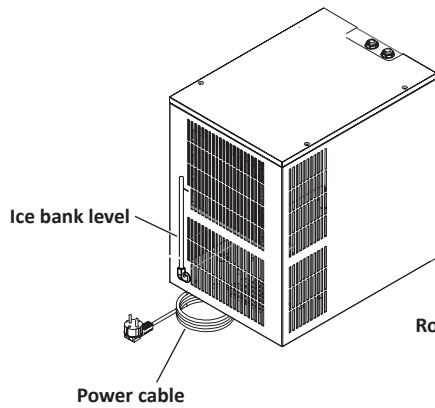
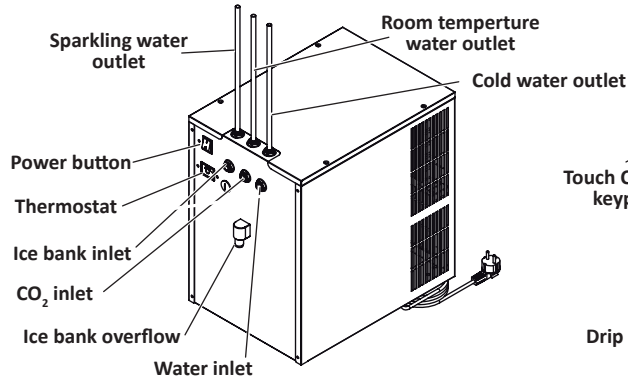

## Fontemagna Bridge

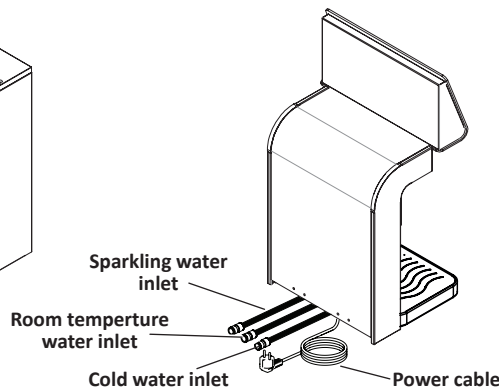
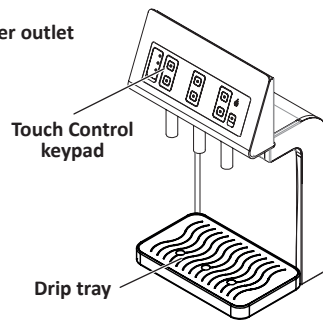

## Column Tap

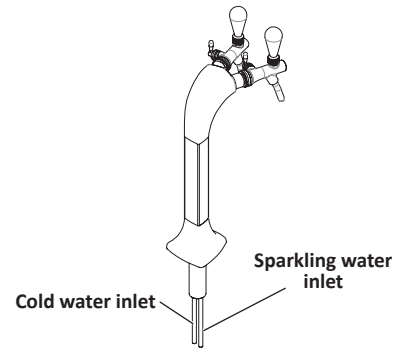
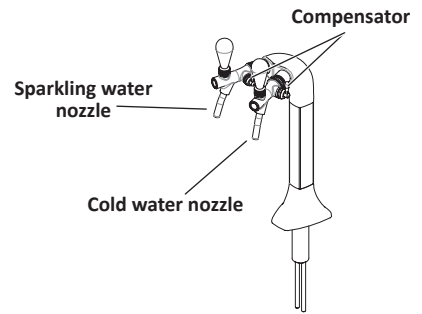

## Fontemagna Bridge Touch Control keypad

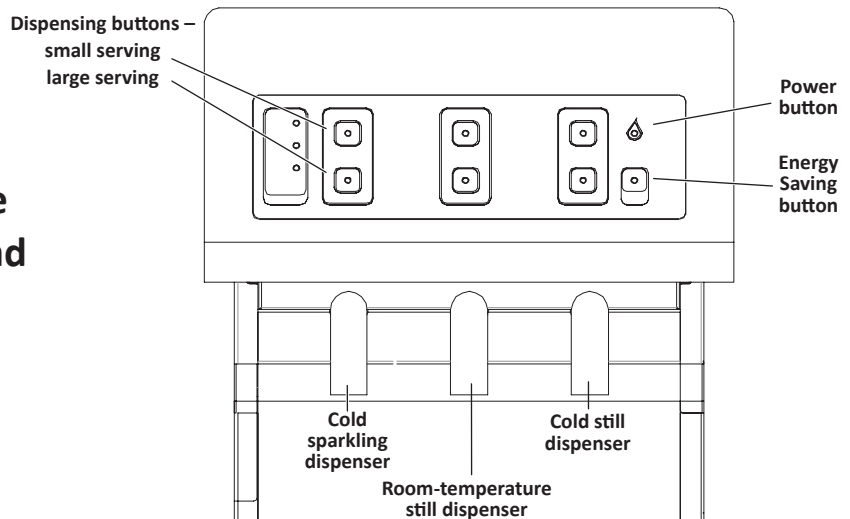

# Product Specifications

Specification	Carbonation Chiller	Fontemagna Bridge	Column Tap
Cooling capacity <i>gal/h (lt/h)</i>	20 (80)		
Continuous supply <i>gal (lt)</i>	12 (45)		
Cold water temperature	37.4°F – 50°F (3°C – 10°C)		
Ice bank capacity <i>gal (lt)</i>	3.7 (14)		
Ice bank <i>lb (kg)</i>	11 (5)		
Cooling technology	ICE BANK single stainless steel coil		
Condensation	Forced ventilation (fan)		
Adjustable thermostat	Yes		
Refrigerant gas	R134a		
Compressor	1/6 HP		
Pump	Professional carbonator pump		
Inlet water pipe	ø 3/8"	ø 3/8"	ø 3/8"
Supply	115V - 60Hz (230V - 50Hz)	115V - 60Hz (230V - 50Hz)	
Power	330W - 3.2A	50W - 0.44 A	
Working room temperature	Min 41°F – Max 107.6°F (Min 5°C – Max 42°C)	Min 41°F – Max 107.6°F (Min 5°C – Max 42°C)	
UNIT WEIGHT <i>lb (kg)</i>	59 (27)	33 (15)	9 (4)
SHIPPING WEIGHT <i>lb (kg)</i>	66 (30)	35 (16)	11 (5)
Dimensions W x D x H <i>in (mm)</i>	12.5 x 18.4 x 18.6 (317 x 467 x 472)	14.2 x 10.2 x 23.8 (361 x 290 x 605)	5.2 x 9.1 x 18.7 (132 x 231 x 475)
Dispensing area height <i>in (mm)</i>		12 (305)	12 (305)
Packaging dimensions <i>in (mm)</i>	16.5 x 23.2 x 28.3 (420 x 590 x 720)	16.1 x 30.5 x 12.0 (410 x 775 x 305)	6.7 x 6.7 x 28.3 (170 x 170 x 720)
Dispensing	3 supply option (sparkling, cold and room temperature water)	3 supply option (sparkling, cold and room temperature water) with customizable portion control system	2 supply option (sparkling and cold water)
Mechanical outlet taps			HQ stainless steel
Push buttons		Electronic touch screen board	
Energy Saving device		Included, dedicated push buttons	
Materials	All robust stainless steel parts	All robust stainless steel, aluminium and glass	Stainless steel (water supply path) and nickel brass (body)

# Before You Begin – Requirements for Installation

## Mounting Dimensions (Carbonation Chiller only)

Under counter (includes 4" clearance on sides and back)

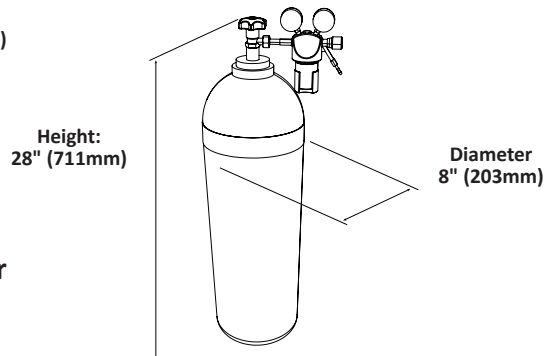
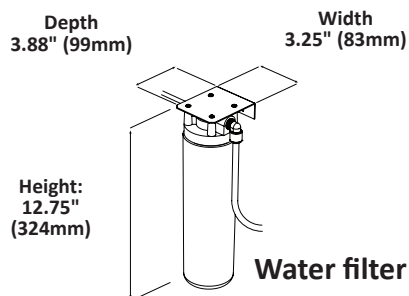
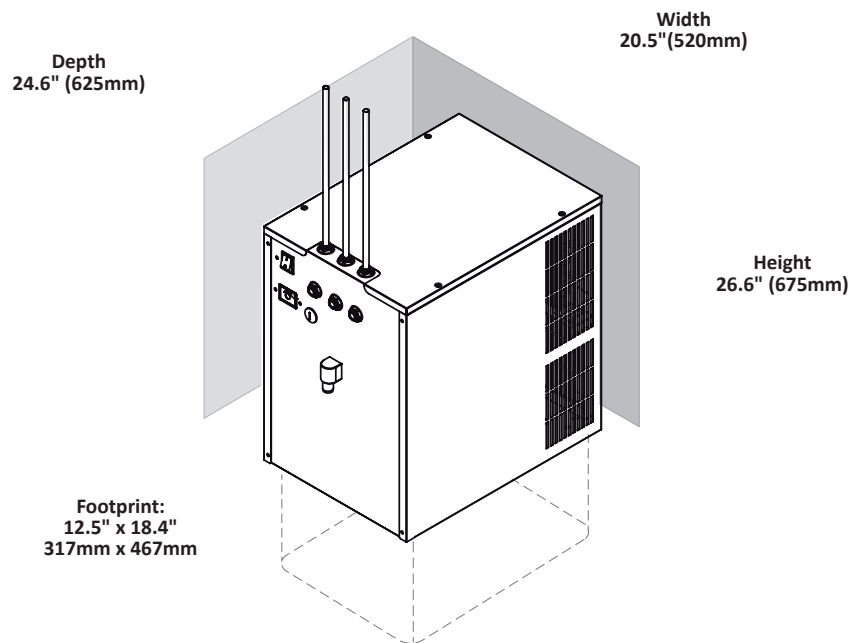

## Operating Environment

- Install the machine in a clean, dry, well-ventilated room. It is designed to function correctly in environments with a temperature of 16°C to 32°C – Climatic Class N, (between 61°F and 90°F).
- Check that the water cooler is level, that it is on a surface that can support its weight and in an environment suitable for its size and use.
- Do not place the machine near a source of heat.
- To guarantee adequate ventilation, leave at least 6" (152 mm) of space around the unit.
- Take care not to damage the cooling fluid circuit: Carbonation Chiller is filled with HFC R134a, which is a highly flammable gas. It is essential to ensure that the tubes of the refrigerant circuit are not damaged.
- The unit is not intended for use by children.
- Keep the areas surrounding the unit dry to avoid the risk of people slipping.
- The unit must not be cleaned with a water jet.

## Water

- Always connect the water cooler to a water main that supplies drinking water only.
- Use of 3/8" diameter connections is recommended.
- Turn off the main water inlet tap if the unit is not to be used for a long period.

## Electrical

- Check that the voltage shown on the serial number plate corresponds to the voltage being supplied at the installation site.
- Do not use extension cables or multiple-power sockets. The machine must be located close enough to a standard power socket that the supplied power cable reaches without stretching.
- After installation, check that the machine is not standing on its power supply cable.
- Ensure that it is possible to disconnect the power supply either by removing the plug or via a two-pole circuit breaker placed upstream of the plug.
- Before any maintenance or cleaning operation is carried out, remove the plug from the socket or disconnect the power supply.
- If the power cable is damaged, it must be replaced by the manufacturer, by its technical support service or by a qualified technician.
- Do not position other electrical equipment in the immediate vicinity of the water cooler.

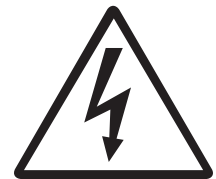

## Tools You Will Need

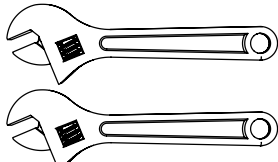

(2) 8" adjustable wrenches

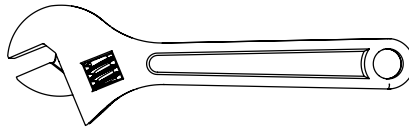

(1) 12" adjustable wrench

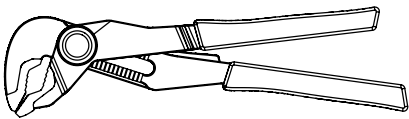

(1) 10" adjustable pliers

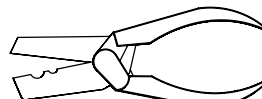

(1) 12" pipe cutter

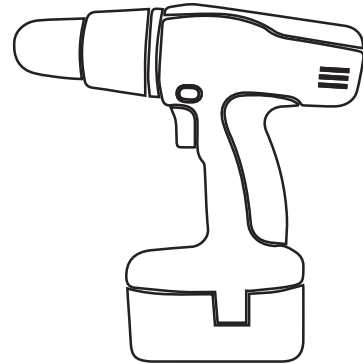

(1) electrical drill

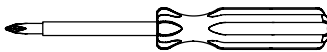

(1) universal screwdriver

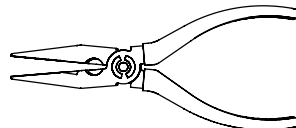

(1) wire cutting pliers



(1) 0.39" drill



(1) 1.57" drill

## Unpacking the Kit

Remove the front panel (labeled FRONT) and cover of the wooden packing case.

Remove the cardboard box and the internal protective packaging by sliding them up and over the top.

Once you have unpacked the machine, check all components to ensure that they are not damaged. Contact the carrier immediately if there has been any damage during shipping.



**NOTICE:** Ensure that your machine is installed by a qualified technician in compliance with the manufacturer's instructions and the local safety guidelines.



**NOTICE:** Only qualified technicians should access the internal components of your machine, other than to fill the ice bank.

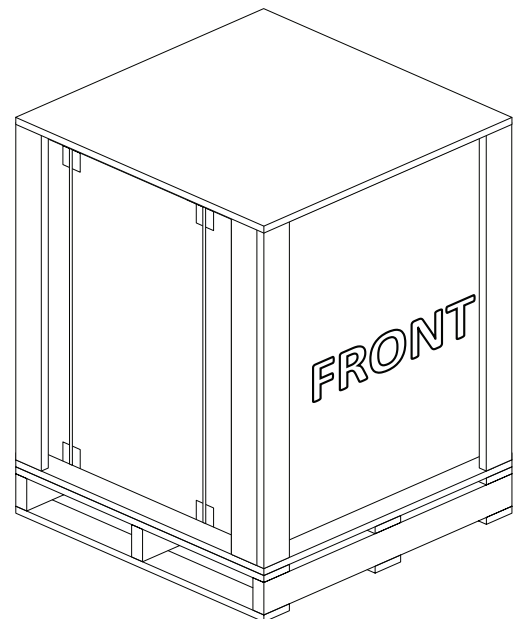

# What's in the Kit

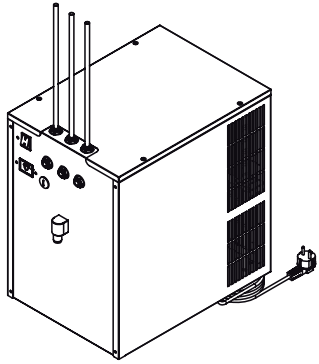

(1) Carbonation Chiller  
 or

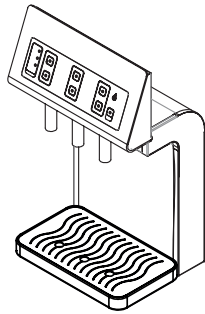

(1) Fontemagna Bridge  
 or

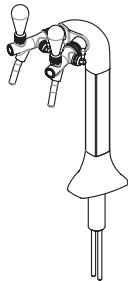

(1) Column Tap

PLUS

(1) CO<sub>2</sub> regulator

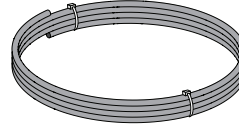

(3) 10' coil water tubing  
 3/8" O.D. (blue)  
 and (3) 10' coils of tubing  
 insulation (not shown)

(1) supply hose 1/2 ips x 3/8  
 tube x 12" long

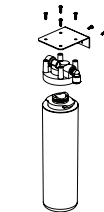

(1) external  
 water filter

(2) 3/8"-quick  
 connect connector



(1) water  
 shutoff valve



(1) water  
 pressure  
 regulator

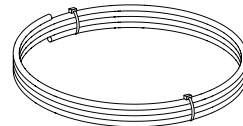

(1) 10' coil CO<sub>2</sub>  
 tubing 1/4" OD  
 (natural)

(1) 4" piece of  
 1/4" OD tubing

(1) 3/8" x 1/4"  
 quick connect  
 connector



PLUS

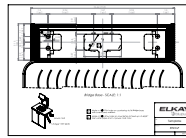

(1) 1:1 drill template

(4) M6 x 1.45" Phillips  
 machine screws



(4) M6 washers



**NOTICE:** CO<sub>2</sub> source is not included and must be supplied separately.

# Installing the Water Cooler and the Supply Head



**CAUTION:** Wear safety gloves when handling the machine. Metal edges are sharp, and touching them could result in minor or moderate injury.



**CAUTION:** Water cooler weighs more than 100 lbs (45 kg) when the ice bank is filled. Lifting without proper support could result in minor or moderate injury.

## 1. Install external water filter and CO<sub>2</sub> cylinder.

1. Use (2) Phillips head screws to mount bracket to under-counter wall.
2. User (4) Phillips head screws to mount filter head to bracket.
3. Remove cap from filter. Insert filter into filter head and turn clockwise (right) until it stops.

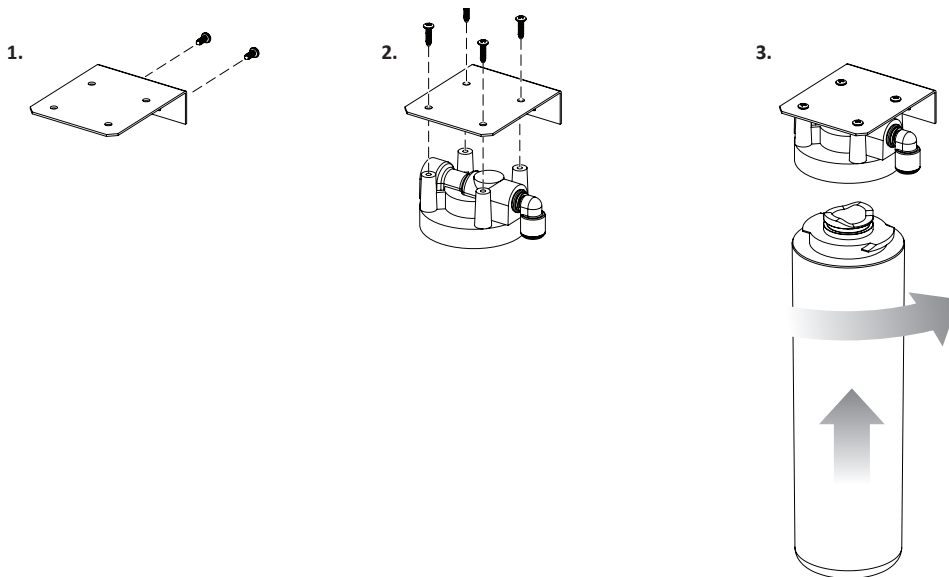

**NOTICE:** Install CO<sub>2</sub> source per manufacturer's recommendations.

## 2. Cut, size and connect water and CO<sub>2</sub> piping to fit your installation.

**NOTICE:** The water pressure entering the machine must be between 14.5 psi (0.10 MPa) minimum and 51 psi (0.35 MPa) maximum.

**NOTICE:** An incoming flow rate of >1.0 gallon/minute is recommended for optimal quality of sparkling water.

**NOTICE:** Check all input piping and connections for leaks before connecting to the machine.

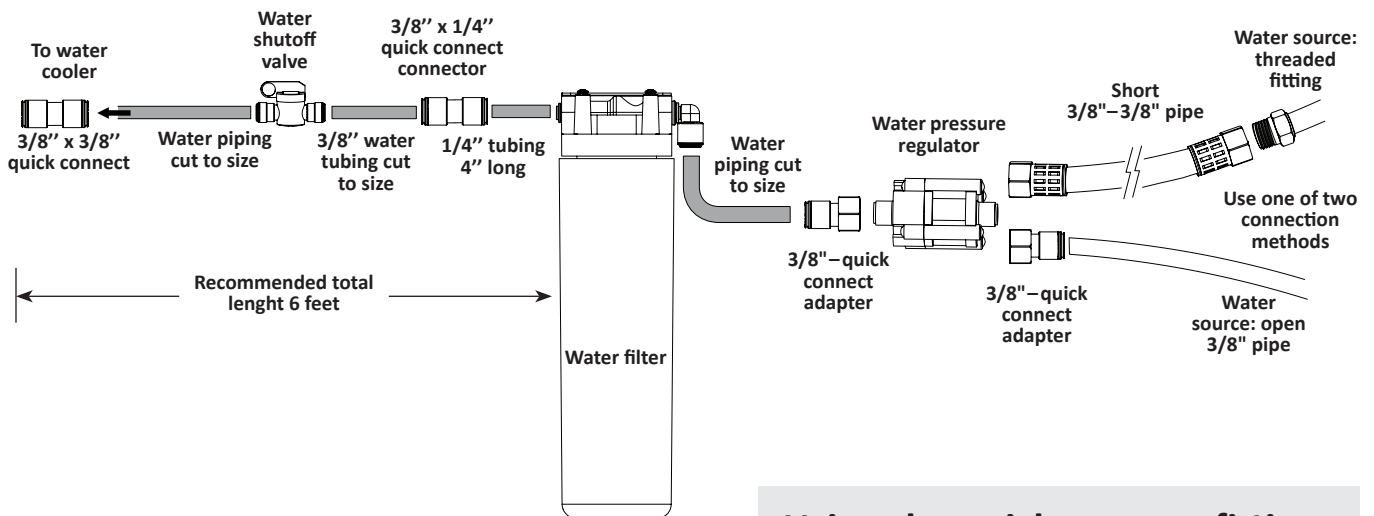

### Using the quick connect fittings

#### To connect:

1. Make clean, 90° cut to piping end.
2. Push piping straight into fitting until it stops.
3. Pull back to check that connection is secure.



#### To disconnect:

1. Press in the end tab.
2. Pull piping out.
3. Release tab.

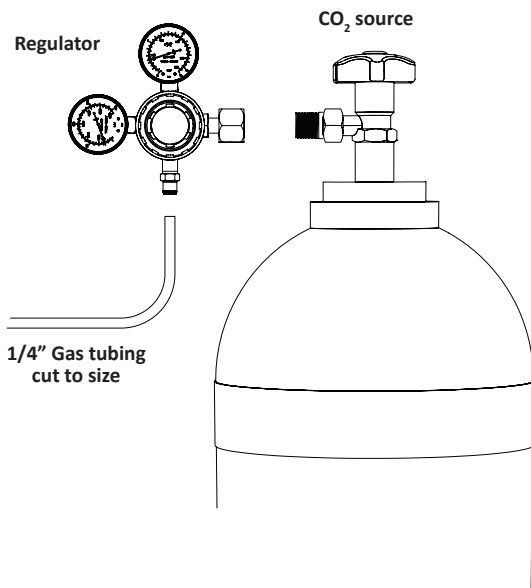
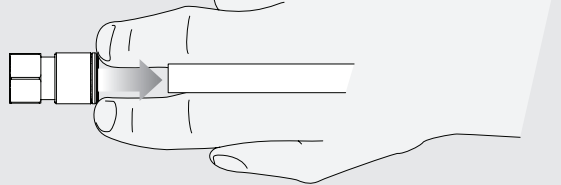

### 3. Fill the ice bank in your water cooler.

1. Insert piping from water supply **(A)** into ice bank 3/8" inlet quick connect on the front side on the machine **(B)**.
2. Fill slowly until water reaches the maximum fill line on the overflow tube on the back side of the machine **(C)**.
3. If water exceeds this level, water will flow from overflow **(D)**.

#### Carbonation Chiller

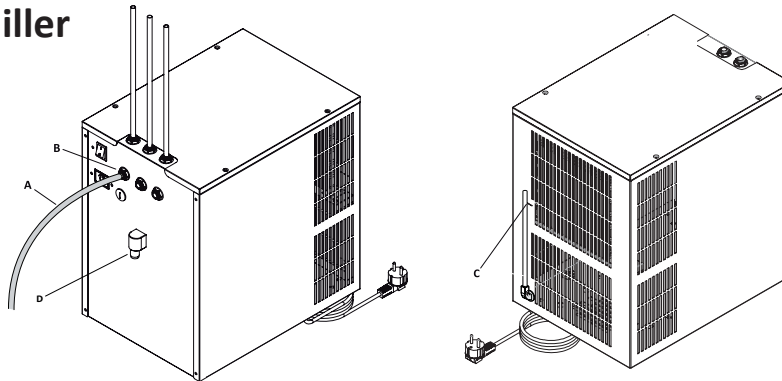

4. If you have to move the unit, remember to empty the ice bank first.
5. Turn off water supply and remove piping from ice bank inlet.

### 4. Place the water cooler in its operating location.



**NOTICE:** Ensure machine remains level while being lifted into place to prevent spillage from ice bank.

### 5. Connect external water and CO<sub>2</sub> piping.

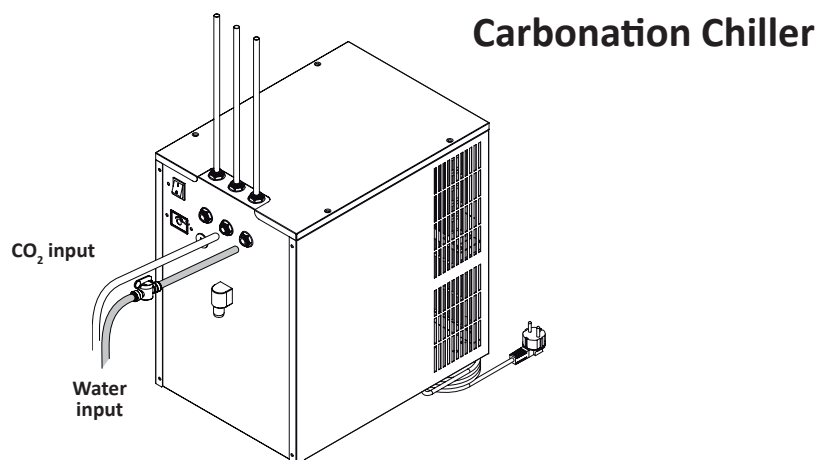

## 6. Place the supply head on the counter top.

---

### Fontemagna Bridge

1. Use the template provided in the kit to drill the mounting holes on the counter top.
2. Insert the inlet tubes of the supply head through the dedicated hole and secure the unit firmly to the surface with the (4) screws M6 - 1mm x 40mm long and (4) M6 washers provided.

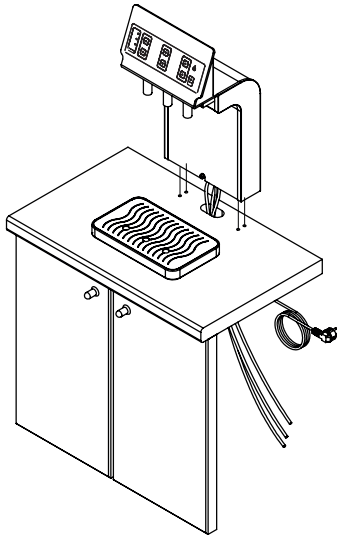

### Column Tap

1. Place the valves and fully tighten the ring nuts. Screw in the knobs on the taps.
2. Drill a 1.375" to 1.5" diameter hole on the counter top.
3. Insert the inlet tubes of the tap through the hole and secure the unit firmly to the counter top with the nut provided.

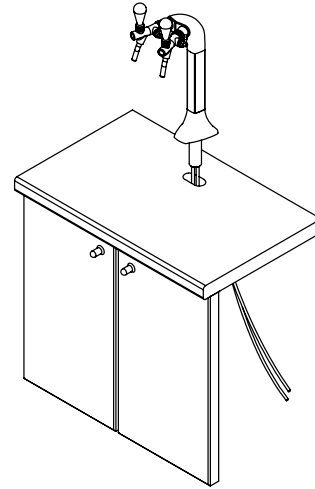

**NOTICE:** If the surface thickness is above 1.45 in (40 mm), buy appropriate replacement screws in a specialized shop (*Fontemagna Bridge only*).

## 7. Connect the supply head to the undercounter water cooler.

---

1. Using the 3/8" tubing supplied, cut the tubing to the desired length and connect the incoming water tubes to the Carbonation Chiller water cooler. Pay attention to the labels on the pipes.
2. Using the insulation supplied, wrap the chilled and sparkling water tubes to minimize condensation.

## 8. Plug the machine into the wall socket and turn it on.

---

1. Connect the power cable to the nearest socket (*Carbonation Chiller and Fontemagna Bridge only*).
2. Flip the power switch at the front of the machine to the "I" position (*Carbonation Chiller only*).



**NOTICE:** Chilling of the ice bank begins immediately when unit is turned on. Complete chilling of ice bank will require 1-3 hours. The machine should not be used as a water dispenser until chilling is complete.

## 9. Purge the water lines.

1. Place receptacle beneath tap to catch dispensed water. Discard water as necessary.

### Fontemagna Bridge

Press and hold  
dispensing button

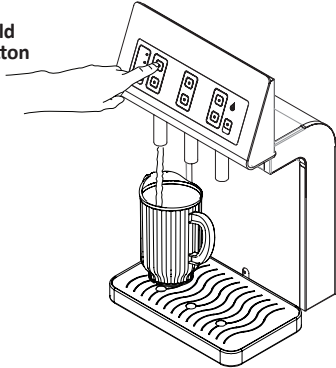

### Column Tap

Open both  
taps

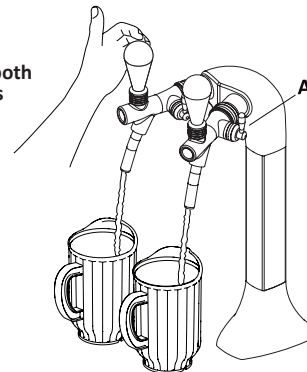

2. Allow water to run continuously until flow is clear of air.
3. Repeat for all taps.



**NOTICE:** On the Column Tap, use the lever (A) to regulate the water flow: rotate counterclockwise to increase the flow or rotate clockwise to decrease it.

## 10. Open the CO<sub>2</sub> valve.

4. Using a screwdriver slowly turn valve screw counterclockwise (left) to open valve.
5. Continue until pressure reads 55 psi to 60 psi max.

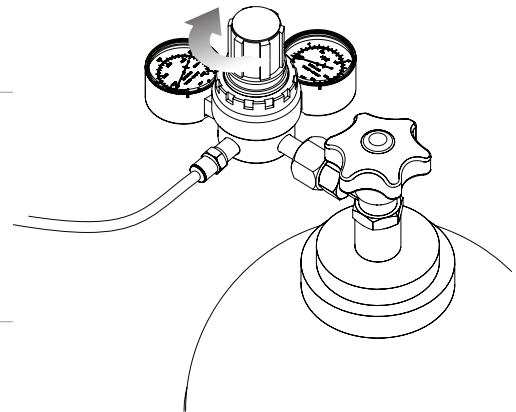

## 11. Re-purge the line for sparkling water.



**NOTICE:** The water will flow flat at first, then gradually become more sparkling as the line is purged of still water.

## 12. Allow machine to complete initial chilldown.



**NOTICE:** Complete chilling of ice bank will require 1-3 hours. The machine should not be used as a water dispenser until chilling is complete.

# Operating the Touch Control Keypad

## Fontemagna Bridge Only

### To turn on the machine

Press the power button.

**Note:** The power button and dispensing button LEDs turn on.

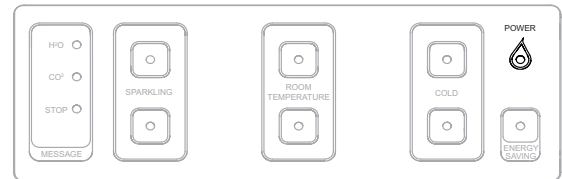

### To turn off the machine

Press the power button a second time.

**Note:** The power button and dispensing button LEDs turn off.

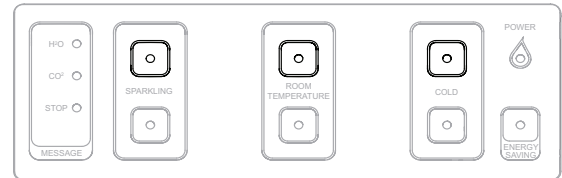

### To dispense a small, single serving size of your water selection

Press the upper button for that dispenser.

**Note:** The button LED turns off while the machine is dispensing.

### To dispense a large serving size of your water selection

Press the lower button for that dispenser.

**Note:** The button LED turns off while the machine is dispensing.

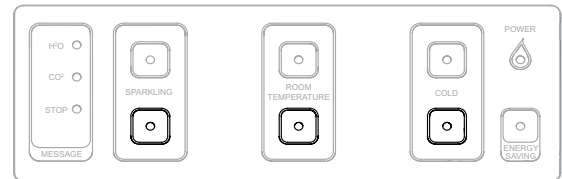

### To stop dispensing before your serving is complete

Press the button a second time.

**Note:** The water flow stops and the LED turns on.

### To turn on Energy Saving mode

Press and release the Energy Saving button.

**Note:** The LED on the Energy Saving button turns on and all other LEDs turn off.

**NOTICE:** Energy Saving mode slows down the activation time of the compression. This mode should only be used when the machine will not be operated, such as when the business has closed for the day.

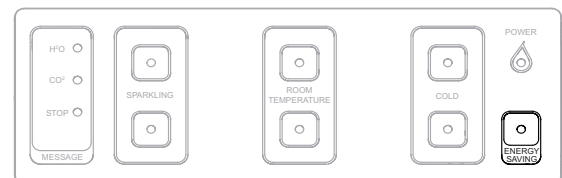

### To turn off Energy Saving mode

Press the Energy Saving button or any of the dispensing buttons.

### To turn on Key Lock

Press and hold the Energy Saving button for more than 4 seconds, until the machine beeps once.

**Note:** All of the button LEDs flash.



**NOTICE:** Key lock deactivates all the buttons on the keypad. It should be activated before the keypad is cleaned.

### To turn off Key Lock

Press and hold the Energy Saving button for more than 4 seconds, until the button LEDs stop flashing.

**Note:** All LEDs return to their default appearance.

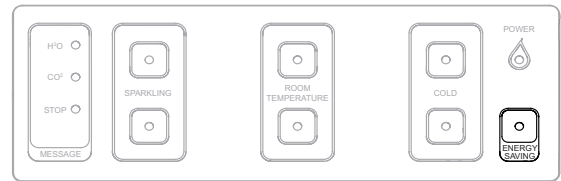

# Programming the Touch Control Keypad

## Fontemagna Bridge Only

By default, the Fontemagna Bridge dispenses a single 7 oz (0.2 liter) serving when the upper dispensing button is pressed, and a 34 oz (1 liter) serving when the lower dispensing button is pressed. You can change the default serving size by entering Programming Mode.

### To enter programming mode

Press and hold the Energy Saving button, plus the two Room Temperature dispensing buttons, until the machine beeps three times.

**Note:** The LEDs in all dispensing buttons flash to indicate they are ready to be programmed.

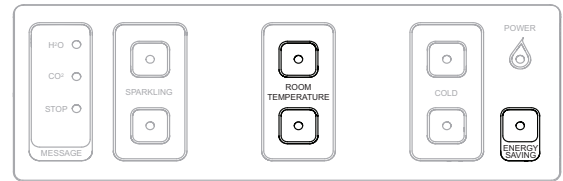

### To reset the serving size for a button

1. Place a correctly sized cup or bottle beneath the dispenser.
2. Press the button to start dispensing. Water flows and the LED for that button shuts off.

**NOTICE:** Water will continue to flow until you press the button a second time.

3. When water has reached to desired level, press the button a second time to stop dispensing. The water flow stops and the LED for that buttons turns back on.

**NOTICE:** The maximum serving size you can set is 101 oz (3 liters). This volume would require a 65-second dispensing session.

4. Repeat these steps for any other buttons you wish to reset.

### To reset all buttons to factory defaults while in programming mode

Press the Energy Saving button.

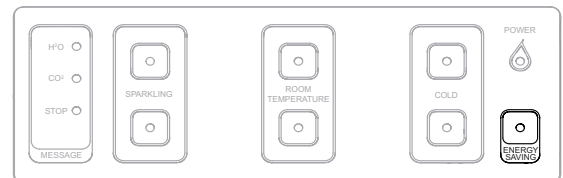

### To exit programming mode

Press and hold the Energy Saving button, plus the two Room Temperature dispensing buttons, until the machine beeps three times.

**Note:** All LEDs return to their default appearance.

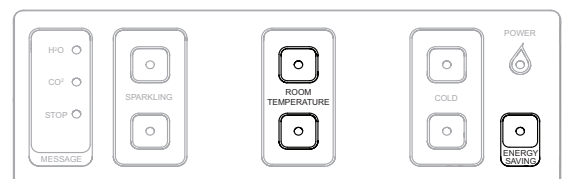

# Routine Maintenance

## Daily

- Clean all external surfaces of the machine, the drip tray and the dispensing nozzles.



**NOTICE:** It is recommended that all external components of the product be cleaned daily.

It is recommended that you use dish soap, warm water and a clean, soft cloth to clean the product.

### DO NOT USE THE FOLLOWING PRODUCTS:

**Do not use ...** chlorine bleach solutions on the product. Chlorides found in most soaps, detergents, bleaches and cleaners can attack stainless steel. These products can cause surface-pitting.

**Do not use ...** metal fibers to clean the product. Metal fibers have a tendency to disintegrate and release small metal particles that are embedded in the surface. Metal particles oxidize and give the impression that the surface of the product is rusting.

**Do not use ...** abrasive cleaners or abrasive pads, as these will scratch the surface of the product.

**Do not use ...** a water jet.

- The glass facing on the Fontemagna Bridge may be cleaned with multi-use cleaners or dedicated glass cleaners.
- To remove limescale, use a slightly acidic product (e.g. citric acid) that has been heavily diluted – excessive acidity may damage the surface of the steel.
- To clean the drip tray, use a diluted limescale cleaner such as citric acid. The drip tray may also be washed in the dishwasher.
- Before cleaning the keypad, turn on Key Lock to prevent accidentally dispensing water. Refer to *To turn on Key Lock on page 17*.

## Weekly

- Use a vacuum to clean out all vents.

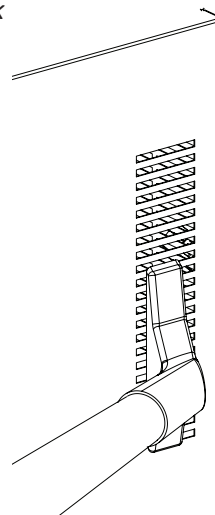

## Twice a Year

- Replace the water filter after 6000 gallons or 6 months, or earlier depending on water quality.



**NOTICE:** The filter head has an internal shutoff valve that stops the flow of water when the filter is removed. It is not necessary to shut off the water supply.

1. Turn used filter counterclockwise (to the left) 1/4 turn to remove from filter head. Pull filter away from head and remove.
2. Remove the cap from the new filter. Place the cap on the used filter to seal it.
3. Insert the new filter into the filter head and turn the filter clockwise (to the right) until it stops.
4. Place a receptacle under the still water dispenser and dispense continuously for a minimum of two gallons to purge air and fine carbon particles from filter.

- Sanitize the machine



**NOTICE:** This operation must be carried out by your ELKAY reseller or by a qualified technician

## When required

- Replace the UV lamp (*Fontemagna Bridge only*)



**CAUTION:** The light emitted by the ultra-violet lamp may cause serious burns to the eyes and skin.

Disconnect the electrical source of supply of the UV radiation before opening the machine.

1. Disconnect the unit from its electrical source.
2. Once the unit is shut down, unscrew the lower screws of the dispensing head (A). Rotate backward the aluminum cover until you have access to the superior dispensing area.
3. Loosen the screws of each dispensing valve in order to remove the UV lamps from their dedicated slot. Disconnect the electrical connector of the UV OUT lamp. Pull the lamp removing it from its fitting holder — handling it carefully.
4. Insert the new lamp and reconnect the connector — handling it carefully.
5. Repeat the procedure for all the dispensing valves.
6. The used UV lamps can be disposed at your local waste management site.

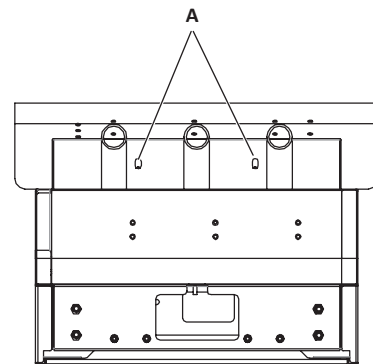

**!** **NOTICE:** This operation must be carried out by your ELKAY reseller or by a qualified technician.

**!** **NOTICE:** For the replacement of UV OUT pipe is not necessary to turn water off.

- Set the thermostat (*Carbonation Chiller only*)

1. Set the thermostat between 5 and 6 to control the temperature of the ice bank.
2. If you want to avoid the formation of ice in the bank, turn the thermostat screw located on the back side of the machine at least 1/4 anti-clockwise.

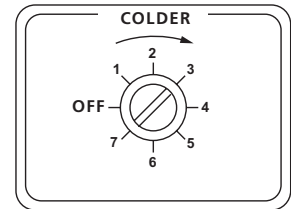

# Troubleshooting

Problem	Possible Cause	Action To Take
No water dispense	The main water valve is closed	Open the valve
	The power switch is set to OFF	Set the power switch to ON
	Malfunction in the ribbon cable connection/ spade connectors ( <i>Compact and Bridge only</i> )	Repair connection to main circuit board
	The water inlet solenoid is not working	Bypass the solenoid and replace it
	The ice bank is frozen	Defrost the ice bank Reduce the thermostat setting
	The low voltage transformer is not working	Replace the transformer

Problem	Possible Cause	Action To Take
Low flow dispense	The filter is clogged	Replace the filter
	The main water valve is not fully opened	Open the valve
	The flow control valve is not fully opened (sparkling water only)	Open the valve
	The CO <sub>2</sub> cylinder is empty (sparkling water only)	Replace the cylinder

Problem	Possible Cause	Action To Take
Sparkling water doesn't come out	The CO <sub>2</sub> cylinder is empty	Replace the cylinder
	The pump is not working	Force the pump to start Replace the pump if broken
	The solenoid is not working	Repair or replace the solenoid
	The flow control valve is too tight	Open the valve

Problem	Possible Cause	Action To Take
Water is not cold enough	The ice bank is empty	Fill the ice bank with water
	The thermostat is not adjusted properly	Adjust the thermostat
	The condenser is dirty	Clean the condenser
	The fan is not working	Replace the fan
	Cold or not warm enough air is blowing through the condenser	Check for faulty compressor or gas leak on the refrigerant circuit and repair
	Malfunction in the over temperature switch/ relay	Switch the machine off and wait 5 minute for restart Replace if broken
	The compressor is not working	Replace the compressor
	Leak in the refrigeration system	Refrigeration system requires repair or replacement

Problem	Possible Cause	Action To Take
Poor sparkling water quality	Incorrect air gap in the carbonator	Close the CO <sub>2</sub> cylinder valve, pull up the ring on safety valve (on the carbonator bowl head) until all air gap is out
	Use of rinse aid or highly polished glass	Avoid excessive use of rinse aid
	The CO <sub>2</sub> regulator is set low	Set the CO <sub>2</sub> regulator between 55-60 psi (3.5-4 bar)
	Water is not cold enough	Set the thermostat properly
	The incoming water pressure is too high	Install an inlet water pressure reducer (included)
	The carbonator bowl is filled by the inlet high water pressure and not by the pump	Install an inlet water pressure reducer (included)
	Incorrect inlet pressure	Install an inlet water pressure reducer (included)

Problem	Possible Cause	Action To Take
Volumetric is not working	The dip switch is not in proper position	Set the dip switch
	The flow meter is not working (orange led flashing)	Replace the flow meter
	The touch pad/button is not working	Check the power supply Replace if broken

Problem	Possible Cause	Action To Take
Yellow (no CO <sub>2</sub> ) alarm on	The CO <sub>2</sub> cylinder is empty	Replace the cylinder
	The CO <sub>2</sub> valve is closed	Open the valve
	The seal is leaking	Tighten regulator connection at CO <sub>2</sub> tank Replace seal
	The CO <sub>2</sub> exit pressure lower than 36 psi (2.5 bar)	Set the pressure between 55-60 psi (3.5-4 bar)
	A reset is needed	Turn the machine off and back on

Problem	Possible Cause	Action To Take
Red (no water) alarm on	The pump runs for 4 minutes continuously	Check why the water is not entering the unit and fix it
	The water valve is closed	Open the valve
	The filter is clogged	Replace the filter
	The main inlet water valve is closed	Open the valve
	The water inlet solenoid is not working ( <i>Compact only</i> )	Look for disconnected or loose wires Replace the solenoid
	The ice bank is frozen	Defrost the ice bank

Problem	Possible Cause	Action To Take
Dripping water	The solenoid is dirty	Open the solenoid and clean it, use diluted solution for removal of mineral and calcium buildup Replace the solenoid
	There's sparkling water still in the nozzle	Clean the nozzle

<b>Problem</b>	<b>Possible Cause</b>	<b>Action To Take</b>
Noise/Vibration	The ice bank is empty	Fill the ice bank
	The agitator or the pump is not covered by water	Fill the ice bank
	The copper tubing is vibrating against the cabinet	Fix the position of the the tubing
	The fan is dirty	Clean or replace it

## Contacting Customer Support

Elkay Manufacturing Company  
2222 Camden Court  
Oak Brook, IL 60523  
800-726-0553