



INSTALLATION AND OPERATING INSTRUCTIONS

Electric Griddles, Drop-In Style

Models: EGD-48 & EGD-72

IMPORTANT FOR FUTURE REFERENCE

Please complete this information and retain this manual for the life of the equipment. For Warranty Service and/or Parts, this information is required.

Model Number

Serial Number

Date Purchased

CONTENTS

General Information	2
Safety Precautions	3
Specifications & Dimensions	3
General Installation Instructions	4
Electrical Data	6
Owner's Information	6
Care & Cleaning	7
Servicing	7
Wiring Diagrams	8
Replacement Parts List	10
Warranty	11



WARNING: For your safety do not store or use gasoline or other flammable vapors or liquids in the vicinity of this or any other appliance. Keep the area free and clear of combustibles. (See ANZI Z83.14B, 1991)



WARNING: Improper installation, operation, service or maintenance can cause property damage, injury or death. Read and understand these instructions thoroughly before positioning, installing, maintaining or servicing this equipment.



P/N 88060-50 9/05

APW WYOTT Foodservice Equipment Company

P.O. Box 1829
Cheyenne, WY 82003

+1 (307) 634-5801 Phone
+1 (307) 637-8071 Fax

+1 (800) 752-0863 Toll Free
www.apwwyott.com

GENERAL INFORMATION

THIS MANUAL SHOULD BE RETAINED FOR FUTURE REFERENCE



CAUTION: These models are designed, built, and sold for commercial use. If these models are positioned so the general public can use the equipment, make sure that cautions, warnings, and operating instructions are clearly posted near each unit so that anyone using the equipment will use it correctly and not injure themselves or harm the equipment.



WARNING: Improper installation, operation, service or maintenance can cause property damage, injury or death. Read and understand these instructions thoroughly before positioning, installing, maintaining or servicing this equipment.



WARNING: Install per the spacing requirements listed in the installation section of this manual. We strongly recommend having a competent professional install the equipment. A licensed electrician should make the electrical connections and connect power to the unit. Local codes should always be used when connecting these units to electrical power. In the absence of local codes, use the latest version of the National Electrical Code.



WARNING: For your safety do not store or use gasoline or other flammable vapors or liquids in the vicinity of this or any other appliance. Keep the area free and clear of combustibles. (See ANZI Z83.14B, 1991)



NOTICE: Instructions to be followed if anyone smells gas should be posted in a prominent place. These may be obtained from the gas supplier.



WARNING: This product is intended for commercial use only. Not for household use Retain this manual for future reference Oven must be kept clear of combustibles at all times



WARNING: SHOCK HAZARD - Do not open any panels that require the use of tools.



IMMEDIATELY INSPECT FOR SHIPPING DAMAGE

All containers should be examined for damage before and during unloading. The freight carrier has assumed responsibility for its safe transit and delivery. If equipment is received damaged, either apparent or concealed, a claim must be made with the delivering carrier.

A) Apparent damage or loss must be noted on the freight bill at the time of delivery. It must then be signed by the carrier representative (Driver). If this is not done, the carrier may refuse the claim. The carrier can supply the necessary forms.

B) Concealed damage or loss if not apparent until after equipment is uncrated, a request for inspection must be made to the carrier within 15 days. The carrier should arrange an inspection. Be certain to hold all contents and packaging material.

Installation and start-up should be performed by a qualified installer who thoroughly read, understands and follows these instructions.

If you have questions concerning the installation, operation, maintenance or service of this product, write Technical Service Department APW/Wyott Foodservice Equipment Company, P.O. Box 1829, Cheyenne, WY 82003.

Congratulations on your purchase of APW Wyott commercial cooking or refrigeration equipment. **APW Wyott** takes pride in the design and quality of our products. When used as intended and with proper care and maintenance, you will experience years of reliable operation from this equipment. To ensure best results, it is important that you read and follow the instructions in this manual carefully.









LOCATION OF DATA PLATE

The data plate is located on the front panel.

SAFETY PRECAUTIONS

Before installing and operating this equipment be sure everyone involved in its operation is fully trained and is aware of all precautions. Accidents and problems can result by a failure to follow fundamental rules and precautions.

The following words and symbols, found in this manual, alert you to hazards to the operator, service personnel or the equipment. The words are defined as follows.

	DANGER: This symbol warns of imminent hazard which will result in serious injury or death.	
	WARNING: This symbol refers to a potential hazard or unsafe practice, which could result in serious injury or death.	
	CAUTION: This symbol refers to a potential hazard or unsafe practice, which may result in minor or moderate injury or product or property damage.	
	NOTICE: This symbol refers to information that needs special attention or must be fully understood even though not dangerous.	

SPECIFICATIONS AND DIMENSIONS

Model	Width in. (mm)	Depth in. (mm)	Height in. (mm)	No. of Elements	kW Per Element	Total kW
EGD-48	49.0/125	29.5/75	0.31/0.8	8	2.7	21.6
EGD-72	72.0/191	29.5/75	0.31/0.8	12	2.7	32.4
EGD-72 Double Trough	72.0/191	32.5/83	0.31/0.8	12	2.7	32.4

Griddle Surface Dimensions:	Model	Width in./cm	Depth in./cm
	EGD-48	46.5/119	23.94/61
	EGD-72	69.5/177	23.94/61

General Installation Instructions:

Caution: **DO NOT** use an open flame to check for leaks. Check all gas piping for leaks with a soap and water solution before operating unit.

NOTICE: THE UNIT, WHEN INSTALLED, MUST BE ELECTRICALLY GROUNDED IN ACCORDANCE WITH LOCAL CODES, OR IN THE ABSENCE OF LOCAL CODES, WITH THE NATIONAL ELECTRICAL CODE, ANSI/NFPA 70, LATEST EDITION.

CANADIAN INSTALLATION MUST COMPLY WITH THE CANADIAN ELECTRICAL CODE, CSA C22.2, AS APPLICABLE.

NOTICE: Local codes regarding installation vary greatly from one area to another. The National Fire Protection Association, Inc., states in its NFPA 96 latest edition that local codes are "authority having jurisdiction" when it comes to requirements for installation of equipment. Therefore, installations should comply with all local codes.

GENERAL INSTALLATION INSTRUCTIONS

With all the large holes cut out, the smaller control panels drilled, and the stiffening angle welded into place the fixture is now ready to receive the griddle.

1. The manufacturer furnishes a gasket or seal that must be placed around the perimeter of the hole in the top as shown in Fig. 4. This gasket may be temporarily held in place with tape. Do not place the staple securing the gasket ends on or near a corner.
2. A number of clamps, such as the one shown in Fig. 4, appear at intervals along the perimeter. Pull clamps outward so the griddle frame clears them when it is dropped into place.
3. Drop the griddle into position by lowering it into the fixture top hole. Make sure the thermostat capillaries are not kinked or pinched when setting the griddle in place. With the griddle in place, the gasket or seal becomes compressed.
4. Slide the clamp inward so it engages the upper part of the protruding angle from the griddle frame. See Fig. 6. Slide the clamp sideways so the notch on it locks against the reinforcement angle. This prevents the clamp from sliding out.
5. Tighten the clamp screws against the angle as shown in Figure 6. This tightening forces the clamps to press down on the griddle body frame extension. The griddle top is now drawn close to the fixture top, compressing the gasket and forming an effective grease guard. Tighten at least one screw on each side before tightening all screws. Do not exceed 60 in/lb torque when tightening bolts.
6. Slide the tray slide (grease drawer receptacle) through the cutout hole on the apron or front of the fixture, resting it on the two "U" braces.
7. Mount the thermostats to the control panel and make the pilot light connections per the accompanying wire diagram. Before making any electrical connections, check nameplate voltage (located on tray slide under grease drawer) to ensure it matches voltage being applied.
8. Set the control panel in place and screw it to the apron using the ½ inch long thread forming screws.
9. Pull the tray slide against the back of the control panel and secure it with the appropriate screws.

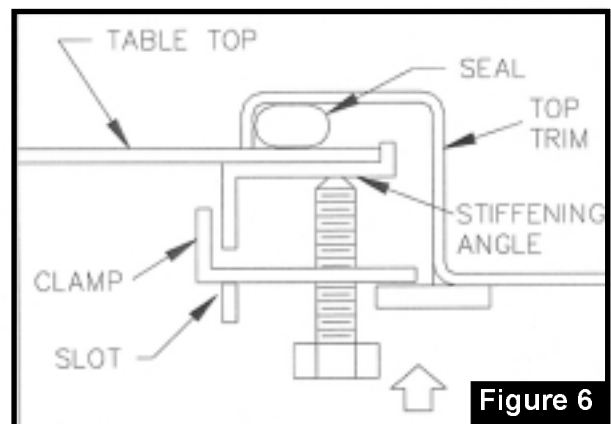
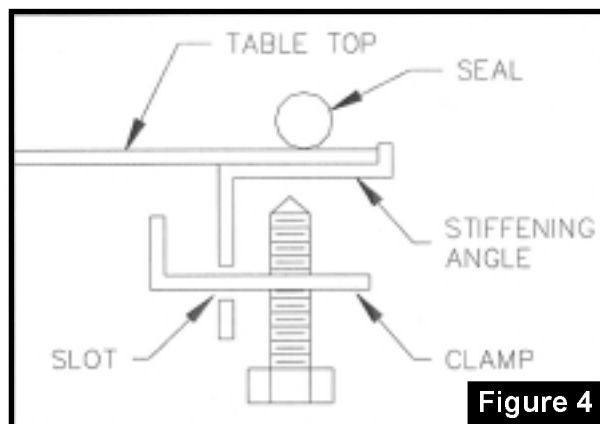
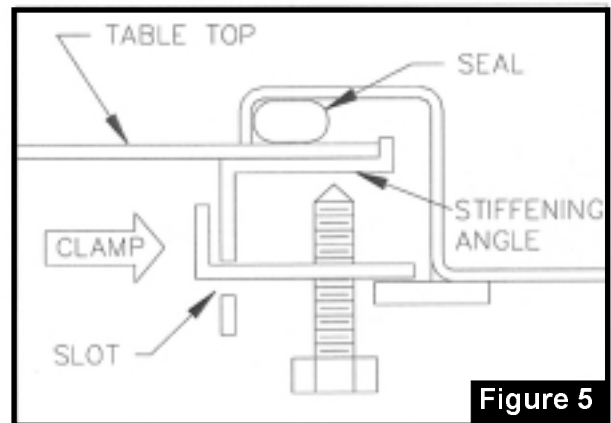
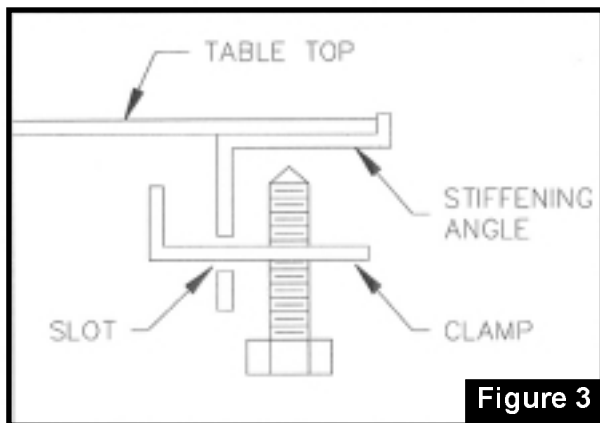

Electrical Connections

Terminal Box Location:

The terminal boxes can be located at either the left front or right rear of the griddle. When shipped from the factory the device has the terminal box attached in the left front position. The box can be relocated to the alternate position by removing two screws.

Loading:

Electrical loadings of the griddles covered by this instruction are tabulated below.

Fusing:

Griddle is not fused and must be connected to a properly fused circuit.

Grounding:

Griddle must be grounded in accordance with the National Electrical Code and applicable local codes.

U.L. CONDITIONS OF ACCEPTABILITY:

1. This equipment must be installed in an all metal fixture of steel or stainless steel construction, .078 inch thick minimum for the top and supporting frame. Side enclosure to be at least 22 MSG minimum thickness.
2. A removable bottom enclosure must be provided under each drop-in unit and be made of metal construction of at least 22 MSG minimum. If ventilating openings are provided in the bottom enclosure, they must not allow the entrance of $\frac{3}{4}$ inch diameter rod nor be located directly below uninsulated live terminals.
3. Minimum spacing between griddle top edge and adjacent items should be: fixture back wall $1\frac{3}{4}$ inch, fixture side enclosure 1 inch, front control panel $\frac{7}{8}$ inch, other drop-in devices 1 inch.
4. Controls shall be mounted on the front vertical surface of the fixture.
5. For supply connections, use wire suitable for at least 90° C (194° F).

NOTES: .

1. Griddle can be mounted with the trough in the front or rear, dimensions shown are for front trough mounting. For rear trough mounting, this dimension must be between $\frac{7}{8}$ " and 2 inches.
2. Table top reinforcement and gasket furnished with the griddle.
3. At the factory, the electrical connection box was installed in the front position. The connection box can be moved to the rear location shown.

IMPORTANT:

1. Any dimension smaller than the minimum or larger than the maximum shown in the table will require corresponding changes to the grease chute by the fabricator by adding an extension to prevent the grease from spilling into the cabinet.
2. Any dimensions smaller than minimum given will require additional panels or sides and back to facilitate servicing.
3. The minimum dimension from the back of the control panel to the front of the griddle top is $\frac{7}{8}$ inch regardless of the shape of the bullnose or table overhang.
4. Griddles are shipped from the factory with dimension "D" at $7\frac{7}{16}$ inch. Moveable braces permit

the fabricator to easily vary this dimension up to 1 0 7/16 inches in increments of 3/4 inch.

5. The minimum space between adjacent griddles must be 1 5/8 inch and between any other combination of drop in cooking equipment must be 1 inch.
6. Electrical wiring crossing the tray slide is to be placed under the tray slide and not above it.
7. The installer or servicer must put the electrical wiring near the control panel inside the wire guide before attaching the control panel to the fixture front.

IMPORTANT STEPS IN INSTALLATION:

1. Griddle position to be no closer than 7/8 inch from component frame edge and control panel.
2. Install the gasket between the griddle top and the table top before clamping. Exercise caution so that the griddle top does not pinch or damage the gasket.

ELECTRICAL DATA

PHASE -LOADING AND LINE AMPERES 50/60 HZ																
Model Number	Power Input (KW)	3-Phase Loading			NOMINAL AMPERES PER LINE											
					3-Phase AC									1-Phase AC		
		KW Per Phase			208 VOLTS			240 VOLTS			480 VOLTS			208 VOLT	240 VOLT	480 VOLT
		Y-Y	Y-Z	X-Z	X	Y	Z	X	Y	Z	X	Y	Z	AC	AC	AC
EGD48	21.6	10.8	5.4	5.4	69.0	69.0	45.0	60.0	60.0	39.0	30.0	30.0	20.0	104	90	45
EGD72	32.4	10.8	10.8	10.8	90.0	90.0	90.0	78.0	78.0	78.0	39.0	39.0	39.0	156	135	68

OWNER'S INFORMATION

Cleaning the Griddle After Uncrating:

Before using for the first time, be sure to remove the factory-applied rust preventative compound. Add a mild detergent to hot water and wash the griddle well. Rinse with a clean, damp cloth and wipe dry.

The Controls:

Turning the dial knob (recessed in the front control panel) controls the heat of the griddle surface. When at least one control is turned on, a signal light in the upper left-hand corner of the control panel will glow continuously. Thus, the operator knows at a glance whether or not the griddle is energized. Separate signal light cycles with each control. Whenever the thermostat calls for heat, the signal light associated with it will be on. Each thermostat controls twelve inches of griddle surface width. Thermostat temperature range is 200° - 450° F +/- 10° F.

Seasoning the Griddle Surface:

After thorough cleaning, the griddle is ready for seasoning. Preheat to 400° F. When the dialed temperature is reached as indicated by the signal lights going off, spread a light film of cooking oil or fat over the entire surface of the griddle. In two minutes, wipe the griddle clean of excess oil. Repeat this operation. The griddle is now ready for use.

Operating Instructions:

1. Preheat griddle (preheat time, 77° F - 350° F, approximately 8 minutes). Set the thermostat dials at the correct griddling temperature for the food to be cooked. A red light will flash on automatically for each section of the griddle when the dial is set and will flash off when the section has reached the dialed temperature. (The signal light will flash on and off during the cooking operation to show that correct temperature is being maintained.) You are now ready to load the griddle.

2. Load Griddle. After preheating, load griddle and cook according to recipe. Turn foods halfway through cooking time unless otherwise specified in recipe.

Economy Hint: Turn griddle OFF (or to lowest thermostat setting) during idle periods.

CAPACITIES	MODEL EGD -48		MODEL EGD -72		BOTH MODELS
	QTY PER LOAD	APPROX HOURLY PRODUCTION	QTY PER LOAD	APPROX HOURLY PRODUCTION	COOKING TIME & TEMP
MEATS					
Hamburgers (2 ½-oz servings, 3 ½ Diam.)	65	945+	86	1300+	3 min. at 350F
Minute Steaks (4-oz. steaks, ½ thick)	24	360+	32	400+	4 min. at 350F
Beef Tenderloin (5-oz. steaks, 1" thick)	48	280+	64	370+	8 min. at 350F-360F
Liver (3-oz. slices, 3/8 thick)	36	450+	48	600+	3-4 min. at 350F
Bacon (22 to 32 slices per lb.)	3 ½ lbs	30 lbs.	4-2/3 lbs	40 lbs	5-6 min. at 350F
Pork Link Sausages (Fresh, 1 ¼ long)	12 lbs	70 lbs	16 lbs	93 lbs	10 min. at 325F
Hot Dogs (split)	64	900+	86	1200+	3 min. at 350F
Ham Steaks (1-lb, tenderized, ½ thick)	24	325+	32	433+	4 min. at 350F
OTHER FOODS					
Eggs, Fried	64	900+	86	1200+	3 min. at 300F
Pancakes (4"Diam.)	40	450+	53	600+	3-4 min. at 360F-375F
Fried Potatoes, Blanched (Servings)	51	750+	67-80	1000+	4 min. at 375F
Fried Onions, Blanched (Servings)	75-77	1100+	100-106	1470+	3 min. at 340F
Hamburger Buns 3.5" dia.	32	600+	43	852+	2 min. at 350F

CARE & CLEANING

1. **IMPORTANT:** At the end of each day's operation, turn all temperature controls to "OFF".
2. After each cooking load, scrape the griddle surface with scraper or rigid spatula to remove excess fat and food particles. ONCE A DAY, or whenever necessary, thoroughly clean and wipe out the grease trough. As necessary during use, wipe out accumulated material to provide good drainage. Remove grease drawer, empty and wash. In general, soap and water with the aid of a sponge or soft cloth will clean the drawer thoroughly. Wipe clean with a damp cloth and dry. Clean control panel with a damp cloth and dry.
3. EACH WEEK, or whenever necessary, clean griddle thoroughly. If desired, use a pumice or griddle stone over surface. Rub with the grain of the metal while still warm. Avoid steel wool! After each thorough cleaning, the cooking surface must be reseasoned. To remove control knobs for cleaning, pull straight out. Wash in soapy water. Rinse, dry and replace on shaft.

SERVICING

Your griddle is covered by a one-year written warranty on parts and labor. If this device should require service, call your local commercial equipment dealer or authorized service station. The nameplate indicating the pertinent electrical data of the griddle is located in the front of the grease drawer receptacle and can be seen readily when the drawer is removed.

EGD-48 WIRING DIAGRAM

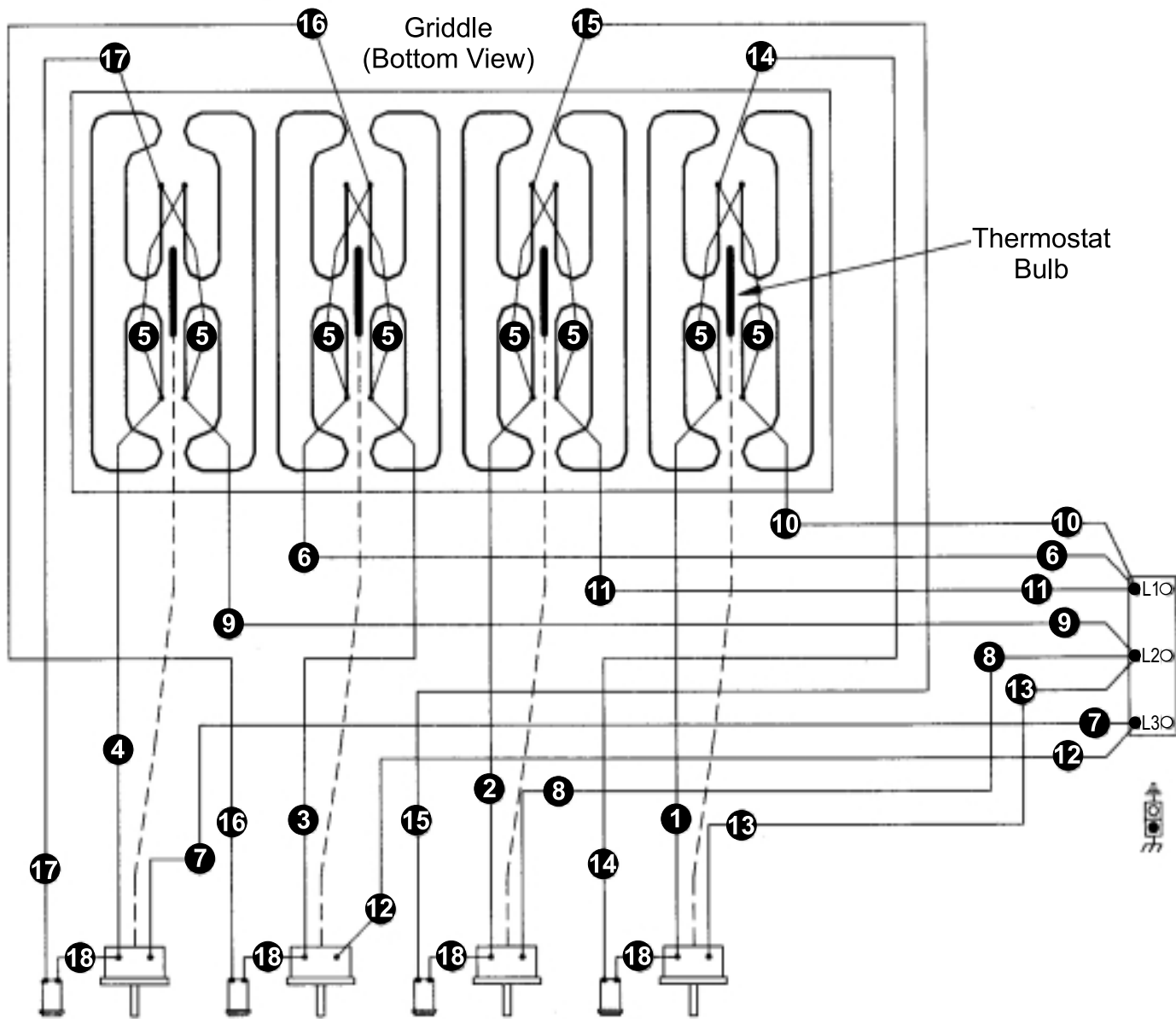

EGD-72 WIRING DIAGRAM

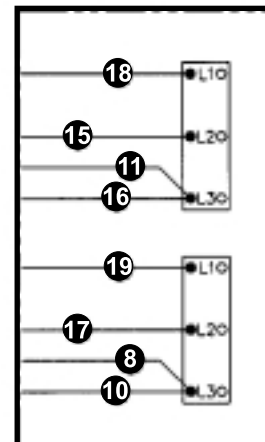
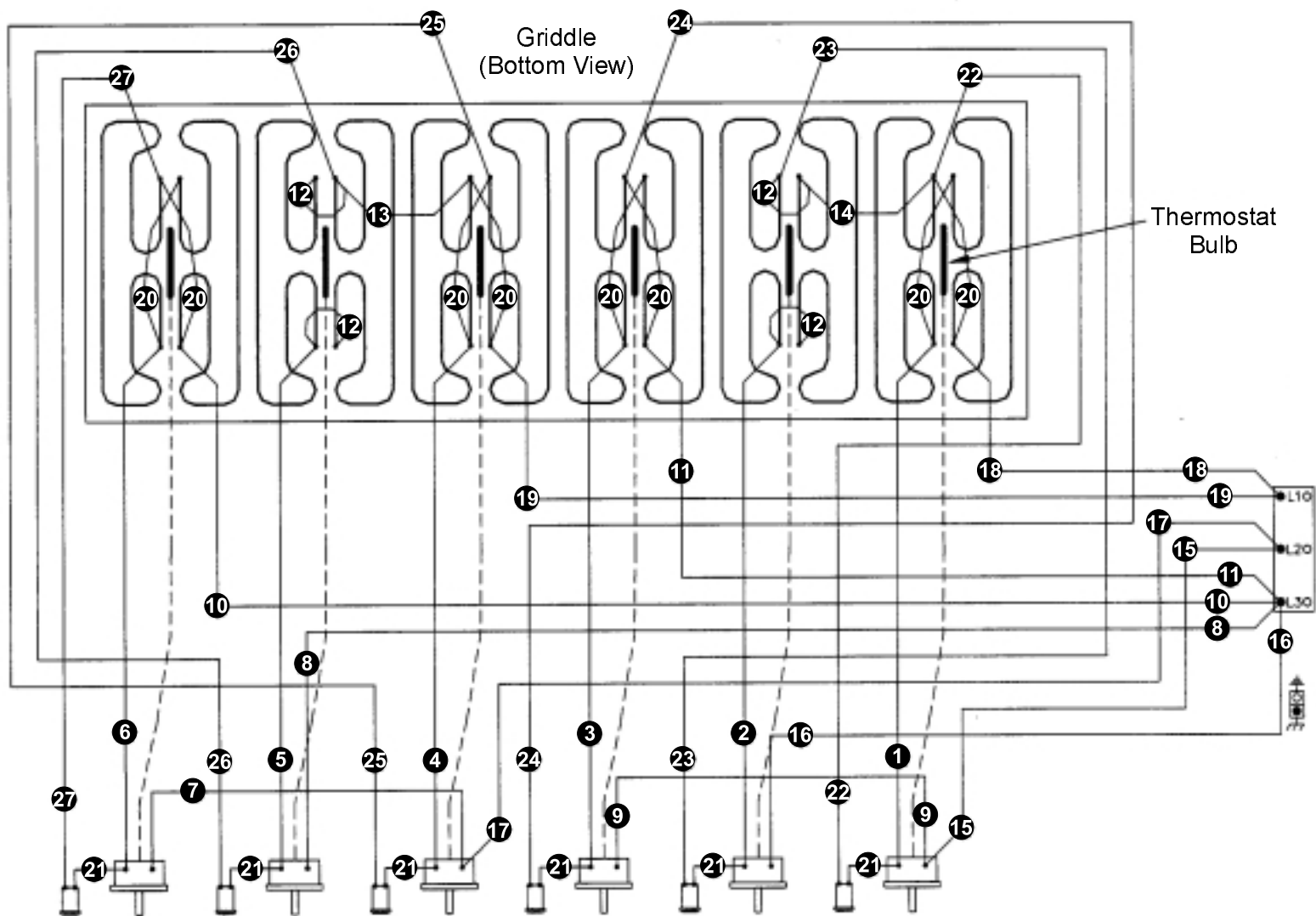

**ALTERNATE WIRING
FOR TWO
POWER SUPPLIES**

PARTS LIST DROP-IN ELECTRIC GRIDDLES, EGD-48 & EGD-72

ITEM	PART NUMBER	DESCRIPTION
1	14397-25	HEATING ELEMENT, 208 VOLT
	14397-26	HEATING ELEMENT, 240 VOLT
2	642567 -01	PRESSURE PLATE
3	646378-03	BULB CLAMP ASSEMBLY
4	646251-01	BAFFLE
5	642578-01	TERMINAL BLOCK BOX
6	642579-01	BOX COVER
7	11260-35	TERMINAL BLOCK
8	647392-01	BOTTOM PANEL, EGD-48, R.H.
	647395-01	BOTTOM PANEL, EGD-48, L.H.
	642584-02	BOTTOM PANEL, EGD-72, SINGLE TROUGH
	642584-01	BOTTOM PANEL, EGD-72, DOUBLE TROUGH
9	643066-01	BRACE ASSEMBLY, EGD -48
	643356-03	BRACE ASSEMBLY, EGD -72
10	653844-01	CONTROL PANEL ASSEMBLY
11	642625-09	KNOB ASSEMBLY
12	15139-03	INDICATOR LIGHT
13	31100-82	CONTROL PANEL SEAL
19	644635-05	THERMOSTAT ASSEMBLY
20	82111 -00	SCREW, 1/4-20 X 3/4
21	84315-00	HEX NUT, 1/4 -20
23	31101-30	SCREW, 10-32 X 1/2
24	84171-00	HEX NUT, 10-32
25	81413-00	SCREW, SELF-TAPPING, 8 -32 X 1/2
26	84364-00	WING NUT, 5/16 -18
27	85195-00	FLAT WASHER, 5/16
28	84317 -00	HEX NUT, 1/4 -20
29	84362-00	HEX NUT, 5/16 -18
30	85196-00	FLAT WASHER, 1/4
31	642626-06	GASKET, GRIDDLE TOP, EGD -48
	642626-07	GASKET, GRIDDLE TOP, EGD -72, SINGLE TROUGH
	642626-10	GASKET, GRIDDLE TOP, EGD -72, DOUBLE TROUGH

APW WYOTT EQUIPMENT LIMITED WARRANTY

APW Wyott Foodservice Equipment Company warrants its equipment against defects in materials and workmanship, subject to the following conditions:

This warranty applies to the original owner only and is not assignable.

Should any product fail to function in its intended manner under normal use within the limits defined in this warranty, at the option of APW Wyott such product will be repaired or replaced by APW Wyott or its Authorized Service Agency. APW Wyott will only be responsible for charges incurred or service performed by its Authorized Service Agencies. The use of other than APW Wyott Authorized Service Agencies will void this warranty and APW Wyott will not be responsible for such work or any charges associated with same. The closest APW Wyott Authorized Service Agent must be used.

This warranty covers products shipped into the 48 contiguous United States, Hawaii, metropolitan areas of Alaska and Canada. There will be no labor coverage for equipment located on any island not connected by roadway to the mainland.

Warranty coverage on products used outside the 48 contiguous United States, Hawaii, and metropolitan areas of Alaska and Canada may vary. Contact the international APW Wyott distributor, dealer, or service agency for details.

Time Period

One year for parts and one year for labor, effective from the date of purchase by the original owner. The Authorized Service Agency may, at their option, require proof of purchase. Parts replaced under this warranty are warranted for the un-expired portion of the original product warranty only.

Exceptions

***Gas/Electric Cookline:** Models GCB, GCRB, GF, GGM, GGT, CHP-H, EF, EG, EHP. Three (3) Year Warranty on all component parts, except switches and thermostats. (2 additional years on parts only. No labor on second or third year.)

***Broiler Briquettes, Rock Grates, Cooking Grates, Burner Shields, Fireboxes:** 90 Day Material Only. No Labor.

***Heat Strips:** Models FD, FDL, FDD, FDDL. Two (2) Year Warranty on element only. No labor second year.

***Glass Windows, Doors, Seals, Rubber Seals, Light Bulbs:** 90 Day Material Only. No Labor.

In all cases, parts covered by extended warranty will be shipped FOB the factory after the first year.

Portable Carry In Products

Equipment weighing over 70 pounds or permanently installed will be serviced on-site as per the terms of this warranty. Equipment weighing 70 pounds or under, and which is not permanently installed, i.e. with cord and plug, is considered portable and is subject to the following warranty handling limitations. If portable equipment fails to operate in its intended manner on the first day of connection, or use, at APW Wyott's option or its Authorized Service Agency, it will be serviced on site or replaced.

From day two through the conclusion of this warranty period, portable units must be taken to or sent prepaid to the APW Wyott Authorized Service Agency for in-warranty repairs. No mileage or travel charges are allowed on portable units after the first day of use. If the customer wants on-site service, they may receive same by paying the travel and mileage charges. Exceptions to this rule: (1) countertop warmers and cookers, which are covered under the Enhanced Warranty Program, and (2) toasters or rollergrills which have in store service.

Exclusions

The following conditions are not covered by warranty:

*Equipment failure relating to improper installation, improper utility connection or supply and problems due to ventilation.

*Equipment that has not been properly maintained, calibration of controls, adjustments, damage from improper cleaning and water damage to controls.

*Equipment that has not been used in an appropriate manner, or has been subject to misuse or misapplication, neglect, abuse, accident, alteration, negligence, damage during transit, delivery or installation, fire, flood, riot or act of god.

*Equipment that has the model number or serial number removed or altered.

If the equipment has been changed, altered, modified or repaired by other than an Authorized Service Agency during or after the warranty period, then the manufacturer shall not be liable for any damages to any person or to any property, which may result from the use of the equipment thereafter.

This warranty does not cover services performed at overtime or premium labor rates. Should service be required at times which normally involve overtime or premium labor rates, the owner shall be charged for the difference between normal service rates and such premium rates. APW Wyott does not assume any liability for extended delays in replacing or repairing any items beyond its control.

In all cases, the use of other than APW Wyott Authorized OEM Replacement Parts will void this warranty.

This equipment is intended for commercial use only. Warranty is void if equipment is installed in other than commercial application.

Water Quality Requirements

Water supply intended for a unit that has in excess of 3.0 grains of hardness per gallon (GPG) must be treated or softened before being used. Water containing over 3.0 GPG will decrease the efficiency and reduce the operation life of the unit.

Note: Product failure caused by liming or sediment buildup is not covered under warranty.

"THE FOREGOING WARRANTY IS IN LIEU OF ANY AND ALL OTHER WARRANTIES EXPRESSED OR IMPLIED INCLUDING ANY IMPLIED WARRANTY OF MERCHANTABILITY OR FITNESS FOR PARTICULAR PURPOSES AND CONSTITUTES THE ENTIRE LIABILITY OF APW WYOTT. IN NO EVENT DOES THE LIMITED WARRANTY EXTEND BEYOND THE TERMS STATED HEREIN."

9/05



24 Hour Toll Free



**Service Hot Line:
1-800-733-2203**

APW WYOTT Foodservice Equipment Company

P.O. Box 1829
Cheyenne, WY 82003

+1 (307) 634-5801 Phone
+1 (307) 637-8071 Fax

+1 (800) 752-0863 Toll Free
www.apwwyott.com