

E3335  
1/22/13

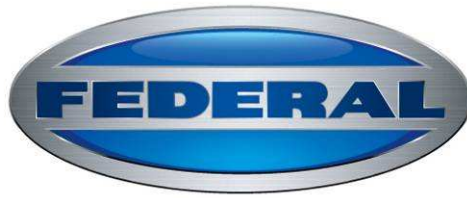

*The Signature of Quality®*

**FEDERAL INDUSTRIES  
ECSS40 & ECSS60 MODELS  
INSTALLATION & OPERATIONS MANUAL**



**KEEP THIS MANUAL FOR FUTURE REFERENCE**

Engineering and technical data are subject to change without notice.

FEDERAL INDUSTRIES  
Toll Free 1(800) 356-4206

215 Federal AVE  
WI Phone (608) 424-3331

Belleville, WI 53508  
Fax: (608) 424-3234

**ECSS E3335**

# CONTENTS

<b>INTRODUCTION.....</b>	<b>3</b>
<b>WARNING LABELS &amp; SAFETY INSTRUCTIONS .....</b>	<b>4</b>
<b>PRE-INSTALLATION PROCEDURES .....</b>	<b>5</b>
INSPECTION FOR SHIPPING DAMAGE .....	5
<b>INSTALLATION INSTRUCTIONS.....</b>	<b>5</b>
LOCATING THE DISPLAY CASE .....	5
ELECTICAL CONNECTION .....	5-6
PERMANENT CONNECTED .....	5-6
CORD CONNECTED .....	6
REMOVING CASE FROM SHIPPING SKID .....	7
REMOVING PACKAGING MATERIAL .....	7
LEVELING THE CASE.....	7
SEALING THE UNIT TO THE FLOOR .....	8
BASE PANELS REMOVAL.....	8
SIDE PANELS.....	8
END PANELS .....	8
BASE COMPONENT LAYOUT SELF CONTAINED.....	9
BASE COMPONENT LAYOUT REMOTE.....	10
CONDENSATE EVAPORATOR .....	11
CONDENSATE PUMP OPTIONAL .....	11
SHELVES.....	12-13
<b>OPERATING INSTRUCTIONS.....</b>	<b>14</b>
USER CONTROLS .....	14
POWER SWITCH .....	14
LIGHT SWITCH .....	14
ELECTRONIC CONTROL.....	14
INITIAL START UP .....	15
PLACING PRODUCT IN CASE .....	15
MAINTANCE .....	16
CLEANING CONDENSER COIL.....	16
<b>CLEANING INSTRUCTIONS.....</b>	<b>17</b>
ACRYLIC AIR DEFLECTOR .....	17
DAILY CLEANING.....	17-18
WEEKLY CLEANING .....	18-19
<b>SERVICE INFORMATION .....</b>	<b>19</b>
PRE-SERVICE CHECKLIST .....	20
SPECIAL SERVICE SITUATIONS .....	21
<b>SALE &amp; DISPOSAL.....</b>	<b>22</b>
<b>REFRIGERATION &amp; ELECTRICAL DATA .....</b>	<b>22</b>
<b>CONTROL OPERATION.....</b>	<b>23</b>
ELECTRONIC CONTROL .....	23
OPERATION.....	23
DEFROST CYCLE.....	23
CONTROL FACTORY SETTING .....	24
CONTROL DISPLAY .....	25
MINIMUM RUN TIMER.....	25
MAXIMUM RUN TIMER .....	25
<b>REFRIGERATION OPERATION .....</b>	<b>25</b>
SELF CONTAINED OPERATION .....	25
REMOTE OPERATION.....	25-26
<b>REPLACEMENT PARTS - .....</b>	<b>27</b>
<b>WIRING DRAWING .....</b>	<b>28-37</b>

---

---

# INTRODUCTION

---

---

Thank you for purchasing a Federal Industries display case. This manual contains important instructions for installing and servicing the IMSS Models. A repair parts list and wiring diagrams are also included in the manual. Read all of these documents carefully before installing or servicing your case.



## NOTICE

**Read this manual before installing your case. Keep this manual and refer to it before doing any service on the equipment. Failure to do so could result in personal injury or damage to the case.**



## NOTICE

**Installation and service of the electrical components in the case must be performed by a licensed electrician.**

**The portions of this manual covering components contain technical instructions are intended only for persons qualified to perform electrical work.**



## DANGER

**Improper or faulty hookup of electrical components in the case can result in severe injury or death.**

**All electrical wiring hookups must be done in accordance with all applicable local, regional, or national standards.**

## SERIAL NUMBER

Record the model and serial numbers of the case for easy reference. Always refer to both model and serial numbers in your correspondence regarding the case.

Case Model \_\_\_\_\_ Serial Number \_\_\_\_\_  
Condensing Unit Model \_\_\_\_\_ Serial Number \_\_\_\_\_

This manual cannot cover every installation, use, or service situation. If you need additional information, call or write us:

**TECHNICAL SERVICE DEPARTMENT  
Federal Industries  
215 Federal AVE  
Belleville, WI 53508  
Toll Free (800) 356-4206 / WI Phone (608) 424-3331**

---

# WARNING LABELS & SAFETY INSTRUCTIONS

---



This is the safety-alert symbol. When you see this symbol on your case or in the manual, be alert to the potential for personal injury or damage to your equipment.

Be sure you understand all safety messages and always follow recommended precautions and safe operating procedures.



## NOTICE TO EMPLOYERS

You must make sure that everyone who installs, uses, or services your case is thoroughly familiar with all safety information and procedures.

Important safety information is presented in this section and throughout the manual. The following signal words are used in the warning and safety messages:

- DANGER:** Severe injury or death will occur if you ignore the message.
- WARNING:** Severe injury or death can occur if you ignore the message.
- CAUTION:** Minor injury or damage to your case can occur if you ignore the message.
- NOTICE:** This is important installation, operation, or service information. If you ignore the message, you may damage your case.

---

The warning and safety labels shown throughout this manual are placed on your Federal Industries case at the factory. Follow all warning label instructions. If any warning or safety labels become lost or damaged, call our customer service department at 1(800) 356-4206 for replacements.

---

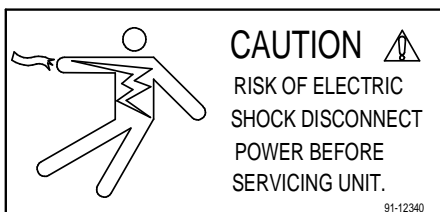

*This label is located behind the removable base and under the display deck pans.*

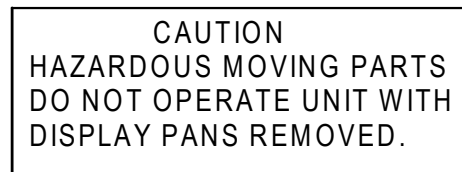

*This label is located below panels display deck pans.*

---

---

# PRE-INSTALLATION PROCEDURES

---

---

## **Inspection For Shipping Damage**

You are responsible for filing all freight claims with the delivering truck line. Inspect all cartons and crates for damage as soon as they arrive. If damage is noted to shipping crates, cartons, or if a shortage is found, note this on the bill of lading (all copies) prior to signing.

If damage is discovered when the case is uncrated, immediately call the delivering truck line and follow-up the call with a written report indicating concealed damage to your shipment. Ask for an immediate inspection of your concealed damaged item. Crating material must be retained to show the inspector from the truck line.

---

---

# INSTALLATION INSTRUCTIONS

---

---

## **Locating The Display Case**

The case should be located where it is not subjected to the direct rays of the sun, heating ducts, grills, radiator, or ceiling fans, nor should it be located near open doors or main door entrances. Also, avoid locations where there is excessive air movement or air disturbances and avoid high humidity locations such as near cases with water misting or fogging devices. Failure to locate this case as stated will reduce the performance of your Island display and will affect temperature of interior of case and product.

The case requires a minimum of 48" of clearance on the three service sides of unit. The paneled side can be placed directly against wall.

## **Electrical Connection**



**DANGER: Improper or faulty hookup of electrical components in the display case can result in severe injury or death.**

### **Permanent Connected (Standard)**

- Only a licensed electrician must perform all case electrical connections.
- All electrical wiring hookups must be done in accordance with all applicable local, regional, or national electrical standards.
- A separate circuit for each display case is required to prevent other appliances on the same circuit from overloading the circuit and causing malfunction.
- The electrical service must be grounded upon installation.
- See the electrical data plate located on the base end, for proper circuit size and wire ampacity.
- Standard Base Electrical Connection: The electrical connection box is in the base for floor electrical connection. The box is accessible by removing the Left Side Base panel. See "Panel

Removal Section” of this manual for panel removal instructions. Remove electrical box cover to access electrical connection



Optional Top Electrical Entrance: The electrical connection box is accessible on the top of the case for ceiling drop electrical connection. Remove electrical box cover to access electrical connection.

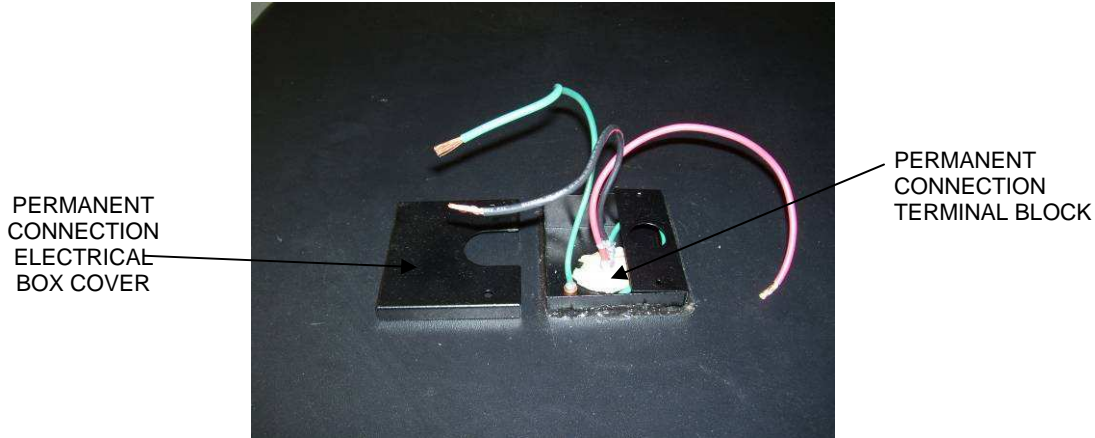

### **Cord Connected (OPTION)**

- A factory installed optional power cord is properly sized to the amperage requirements of the case. See the electrical data plate located on the rear exterior of the case for the proper circuit size for each case.
- The cord is factory installed protruding from the rear paneled side of the case.
- A separate circuit for each display case is required to prevent other appliances on the same circuit from overloading the circuit and causing malfunction.



## Removing Case From Shipping Skid

**CAUTION:** Do not push against the clear acrylic deflector around the sides and nose.  
Doing so can cause the acrylic to break.  
Do not lift or push on the top canopy located on top of the case.  
Doing so can permanently damage the tower frame.  
Care must be taken not to damage or tip the case when removing it from the skid or moving the case.

Remove the screws and brackets that secure the case to the skid. Remove the brackets from the case.

Note that the case may have optional wheels installed and once the brackets holding the case to the skid are removed the case will roll.



## Removing Packaging Material

Remove bubble wrap and packing material for all shelves and panel, brackets, etc. If it is necessary to remove tape residue from plastic materials, use cleaning compounds recommended in the cleaning section of this manual.

## Leveling The Case

The case must be level for proper drainage of defrost water to the condensate pump.

Check the level of the case where the display overhangs the base.  
Adjust levelers as needed to **level** the case side to side.  
A wrench is included to aid in adjusting leg levelers.

**NOTE:** Use a wood or plastic shim under each leg leveler to avoid scratching the tile floor.

## **SEALING THE UNIT TO FLOOR**

After the unit is positioned and the leg levelers are turned out, the unit needs to be sealed to the floor for NSF approved installation.

### **Base Panel Removal**



**DANGER: Electric shock hazard. Do not operate unit with panels removed.**

Panels must be in place when operating the case.

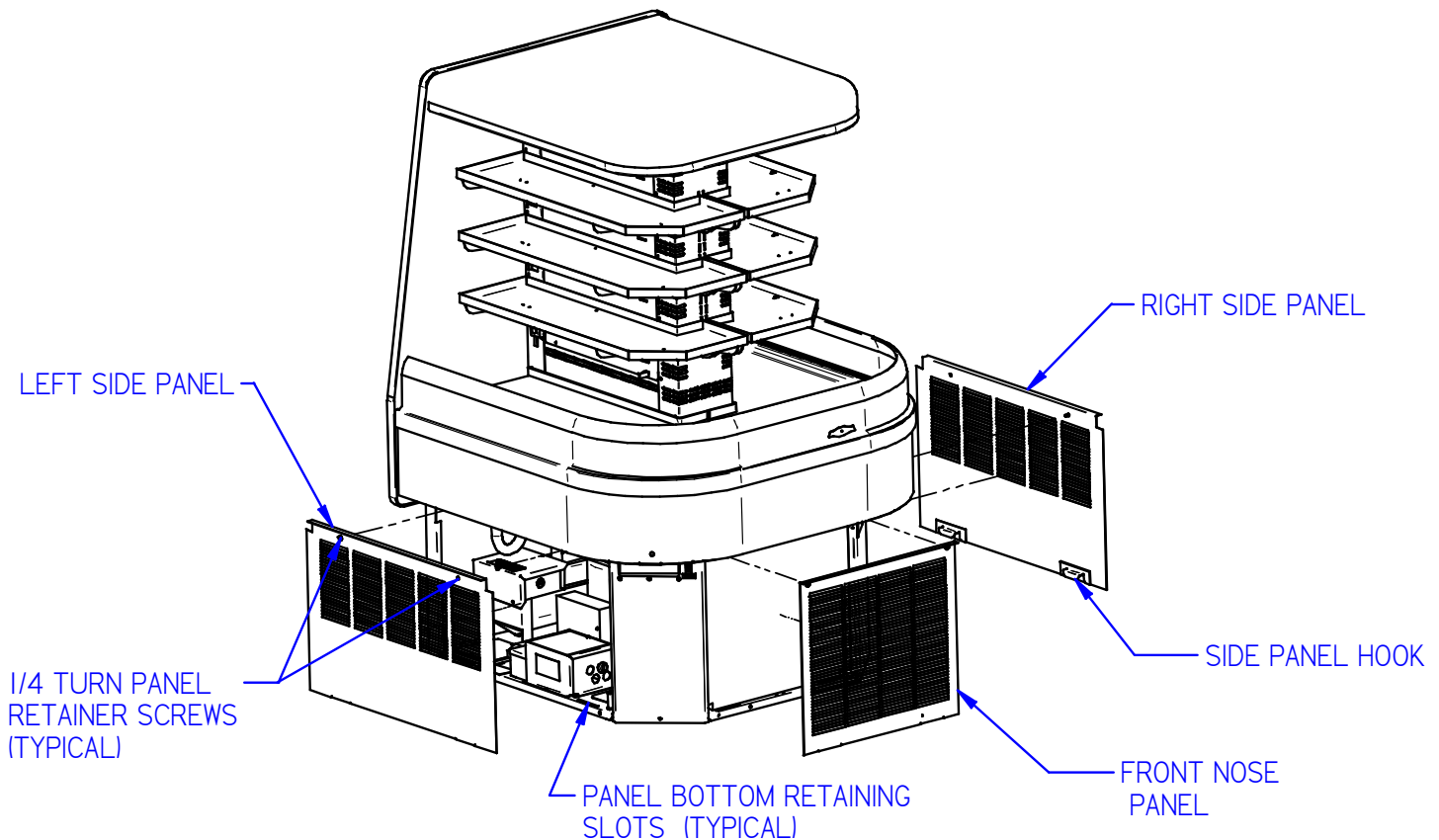

### **Typical Panels Removal**

1. Loosen the (2)  $\frac{1}{4}$  turn retainer screws from top of panel.  
(The screws will stay on the panel even after they are detached from base)
2. Tilt the top of the panel away from the base and pull up on panel to allow the side panel hooks to pull out of the side panel slots.
3. Set the panel in safe place to prevent damage.
4. Reinstall panels in the reverse order.

## Base Component Layout ECSS40SC Self Contained

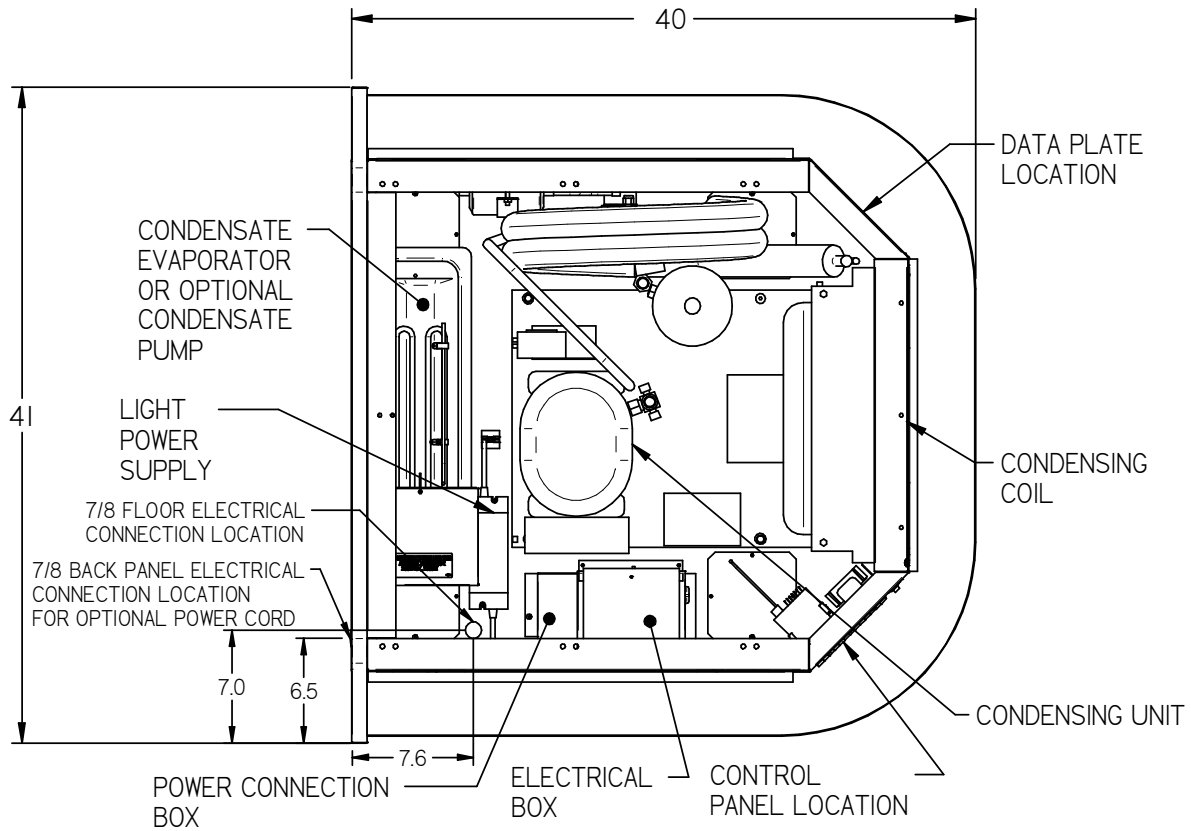

## Base Component Layout ECSS60SC Self Contained

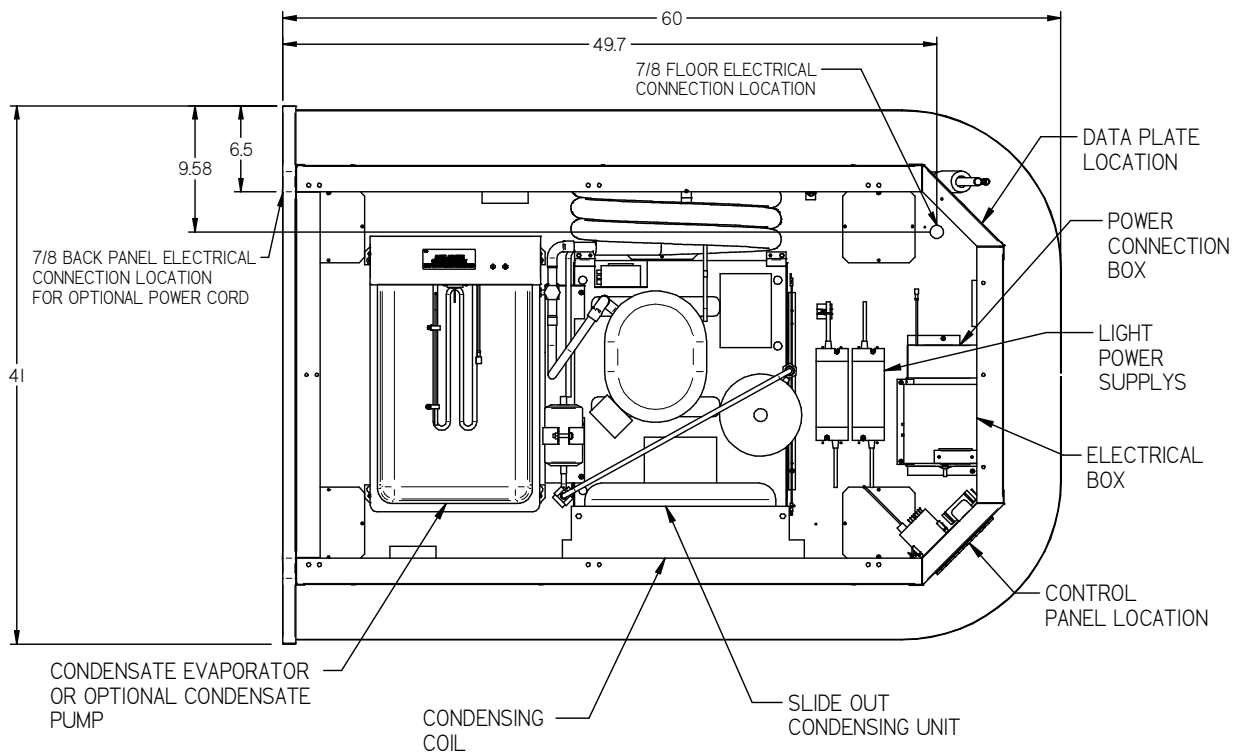

## Base Component Layout ECSS40R Remote

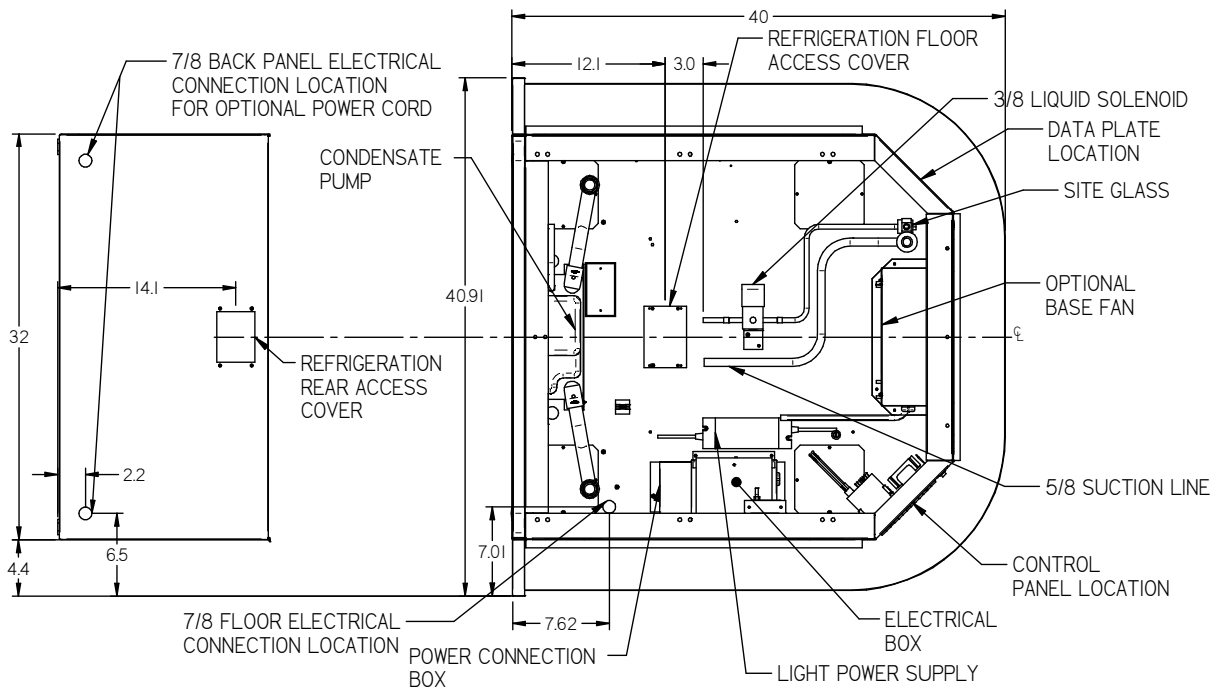

## Base Component Layout ECSS60R Remote

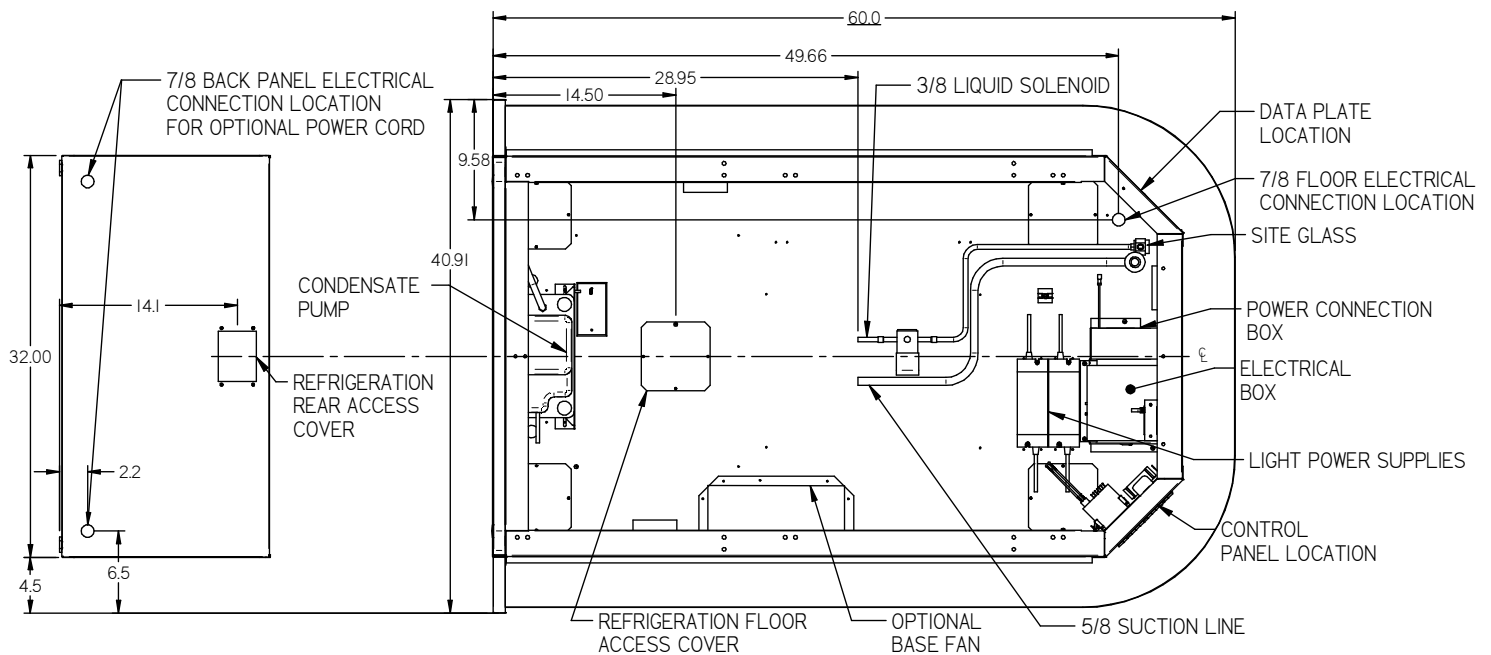

## **Condensate Evaporator**



**NOTICE:** During normal defrost cycles, steam from the condensate evaporator may be visible around the case.

The standard case is furnished with an electric condensate evaporator. Plumbing connections are not required.

The condensate evaporator can be removed from the case and the condensate drain can be plumbed to a drain to conserve energy if desired. Disconnect the condensate evaporator wires at the condensate evaporator to remove. This must be done by a qualified electrician.

This is an open merchandiser and at times can produce a large amount of condensate water. To ensure that adequate evaporator capacity is available, a high wattage heater is used. The heater turns off automatically when the water level in the pan drops.

Check that the float is positioned correctly and that the switch operates at time of installation.

Make sure that the drain line has not been dislodged during shipment and that the drain trap terminates properly over the water reservoir.

## **Optional Condensate Pump**

**NOTICE:** This unit could be shipped with an optional condensate pump. The pump has a float that turns the pump on automatically when needed. The pump is mounted in the base compartment. The pump should be cleaned and inspected every 3-4 months.

**Note:** There is a piece of cardboard that has to be removed from the side of the pump to free up the float. If this is not done, the pump will not turn on and the pan will overflow.

## Shelves

The ECSS has solid metal shelves with LED lighting as standard.

There are (3) brackets required for each shelf (2) long brackets and (1) short brackets. The long brackets are for the long side of case and the short brackets are at the short end of case. The long bracket with cord retainer clip must be used at the panel end back of case where the light cord plugs in.

The shelves are adjustable in ~ 1 1/16" increments.

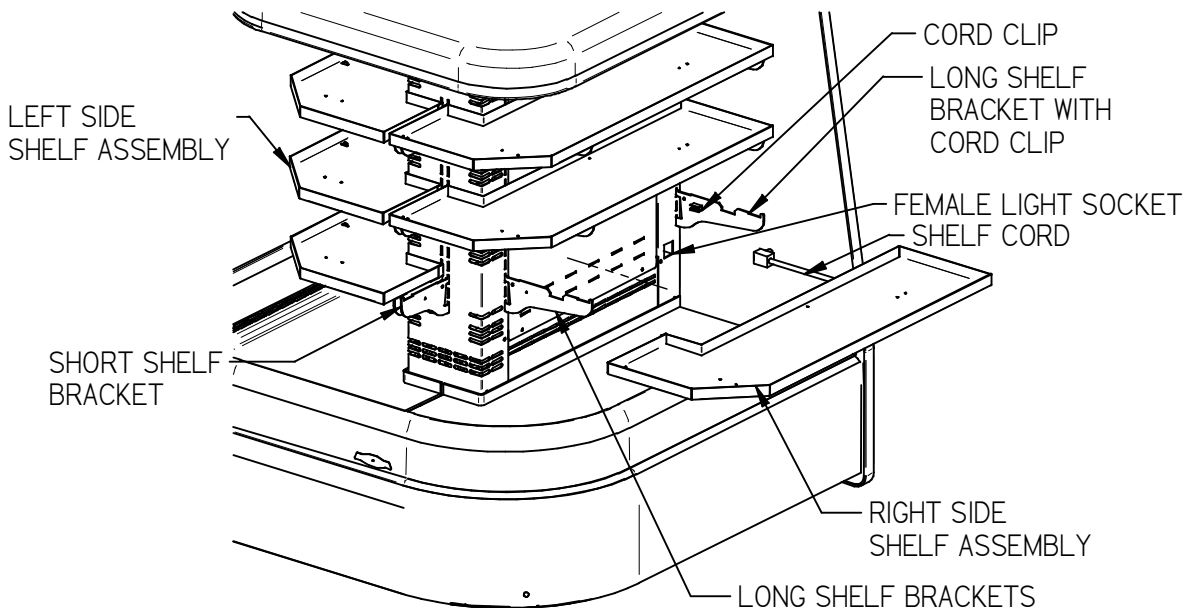

1. Turn the light switch to the off position.
2. Follow the instruction in the illustration below and insert (1) of the (3) shelf brackets in the desired tower slot on one side of the case. Place the additional shelf brackets in the same height level on the opposite end of case. The short brackets must go on the short end and (2) long brackets must go on the long end. The long bracket with a shelf light cord retainer clip must be on the back side next to the shelf light receptacle.

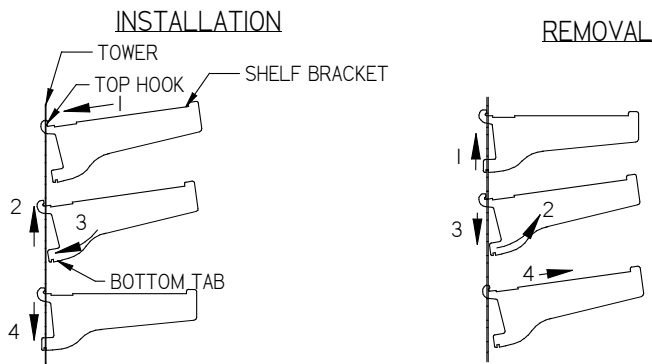

- |  |   |
|--|---|
| <ol style="list-style-type: none"> <li>1. Place shelf bracket top hook into desired slot in the tower.</li> <li>2. Lift shelf bracket top hook to allow shelf bracket bottom tab to clear slot in tower.</li> <li>3. Swing shelf bracket bottom tab into tower slot.</li> <li>4. Place the shelf bracket notch onto bottom of tower slot.</li> </ol> | <ol style="list-style-type: none"> <li>1. Lift shelf bracket up to allow shelf bracket notch to clear the bottom of slot in tower.</li> <li>2. Swing shelf bracket bottom tab out of slot in tower.</li> <li>3. Drop shelf bracket down to allow shelf bracket top hook to clear the slot in tower.</li> <li>4. Remove shelf bracket top from slot in tower.</li> </ol> |
|--|---|

3. Set the shelf on to the brackets and place the bracket retainer tip into slots on shelf.
4. Push shelf light cords into plastic shelf cord retainer clip located on inside of shelf bracket.
5. Remove the cap from the appropriate female light sockets.
6. If the socket is not being used for a shelf light, the cap must be plugged into socket to prevent contamination and moisture out of the socket.
7. Plug in each shelf light by aligning the male pins on the appropriate shelf light cord plugs with the female light sockets and push together. **IMPORTANT:** Do not roll plug during insertion.



8. Place extra cord into cord clip as shown to keep it out of the way.



9. Removal of shelving is performed by following steps in reverse order.

---

---

# OPERATING INSTRUCTIONS

---

---

## User Controls



### ***Power Switch***

The unit has a power switch that turns off power to the entire unit, including the condensate evaporator and the lights. This switch is located behind a lift up panel on the unit base.

### ***Light Switch***

The unit has a light switch that turns on and off the interior lights of unit. This switch is located below the lift up panel on the unit base.

### ***Electronic Control***

This control is located behind a lift up panel on the unit base.

#### ***Temperature Control Knob***

This controls the temperature of the display interior of case.

-OFF: Turning the control counterclockwise to the "WARM" setting is an Off position, this position turns the refrigeration off and all indicator lights will also be off at this setting.

-ON; The control will be on from the warmest setting at "1" and the coldest setting at "COLD".

#### ***Cooling light***

This light will be on when control requires refrigeration to be on. The compressor / condensing unit should be running to cool the case.

#### ***Defrost light***

This light will be on when control when refrigeration is defrosting allowing ice to melt off of evaporator coil. The number of times and length of defrost will vary depending on case environment.

#### ***Alarm light***

This light indicates that there is a problem with case or electronic control and service should be called.

## **Initial Start-Up**

After all the checks outlined in the installation section of this manual have been made, the case is ready to be put into service. Turn on the Power at the breaker box and flip the Power Switch and Light Switch on unit to the on position.

At start up from a warm unit, it is recommended that the temperature control is set at a warm setting, such as 1 on the dial. After the unit has gone through several cycles, turn the control to a mid range setting, then to a colder setting if necessary to maintain desired product temperature



**NOTICE: This refrigerated display case is designed to operate in a maximum environment of 75 DEG. F and 55% relative humidity. Exceeding these limits will cause poor case performance and excessive sweating.**

## **Placing Product into Case**

- Do not exceed 75 pounds of weight per shelf. Heavy product should be distributed evenly across the entire shelving area.
- Determine desired shelving location before placing product in case. Product must be removed to readjust shelf location.
- Allow a minimum of 2” between top of product and bottom of shelf.
- Do not overhang the front or rear of shelves with product. Improper clearance in front and rear of shelf will block the refrigerated airflow and will cause product loss.
- Do not block the slots along the front and rear air discharge slots. Covering these slots will block the refrigerated airflow and could cause product loss.
- The display deck is removable for cleaning and can become dislodged in shipment. To ensure proper airflow and performance of the case, make sure that the display deck is pushed completely down.
- Allow refrigerated models to run for at least two hours before placing pre-chilled product into unit.



**NOTICE: CASE MUST BE STOCKED WITH PRE-CHILLED PRODUCT ONLY.**



**NOTICE: This refrigerated display case is designed to operate in a maximum environment of 75 DEG. F and 55% relative humidity. Exceeding these limits will cause poor case performance and sweating of glass panels.**

## Maintenance

### Cleaning Condenser Coil



**NOTICE:**

**Condenser coil must be cleaned a minimum of twice per month to insure proper refrigeration performance and prevent compressor failure. Failure to clean condenser coil will void condenser warranty.**

It is very important that the Condenser coil is cleaned twice per month to insure proper refrigeration performance and to prevent compressor failure. Failure to clean condenser coil will void condenser warranty. This procedure is for Self Contained models. The remote condenser coil must also be cleaned at same intervals.

1. Disconnect power to the unit.
2. Remove the Front Nose Panel as described in the “Bottom Panel Removal section of this manual”
3. Carefully vacuum the front surface of condenser coil. Take care not to bend coil fins with vacuum cleaner nozzle.
4. Reinstall Front Nose Panel.

VACUUM FRONT  
SURFACE OF  
CONDENSER COIL



---

---

# CLEANING INSTRUCTIONS

---

---

## Acrylic Air Deflector Cleaning



**NOTICE:** Clear acrylic air deflector requires special washing procedures to prevent hazing and yellowing of material.

**NEVER USE** paper towels (wet or dry) for cleaning or drying and never use a dry towel.  
**NEVER USE** glass cleaner of any kind.

Lightly dust (not wipe) surface with a damp Micro Fiber towel or chamois. The surface can then be washed using a small amount of dishwashing detergent such as Dawn or Joy and lukewarm water. Use a Micro Fiber towel or chamois, applying only light pressure. The cloth or chamois must be kept free of grit by frequently rinsing. Rinse surface with clear water and dry by blotting with a damp Micro Fiber towel or chamois.

## Daily Cleaning

The case should be cleaned thoroughly, as described in the weekly cleaning section, before it is used for the first time.



**NOTICE:** Avoid splashing or soaking any electrical components with water to prevent electrical damage to the case.



**NOTICE:** Shut off lights and power switches and remove all products from case. Allow sufficient time for the unit to reach room temperature before proceeding with cleaning.



**NOTICE:** Remove all products from the case before proceeding with cleaning procedure.



**NOTICE:** Acrylic air deflector requires special washing procedures to prevent hazing and yellowing of material. Clean as described in “Acrylic Air Deflector Cleaning” section of this manual.

**Note:** For major spills or foreign material buildup use complete weekly cleaning instructions.

**Note:** Detergents are not recommended and do not use abrasive cleaners or pads to prevent scratching of surfaces.

1. Dip rag in warm soapy water and ring out thoroughly. Wipe complete interior of case and dry with soft dry towel.
2. The remaining exterior surface should be wiped down using any ammoniated cleaners or soapy warm water and dried with soft dry towel..
3. **IMPORTANT:** Cleaning the clear acrylic plastic front air deflector requires special care to prevent hazing and yellowing of material. Clean as described in “Acrylic Air Deflector Cleaning” section of this manual.

## Weekly Cleaning



### NOTICE:

Avoid splashing or soaking any electrical components with water to prevent electrical damage to the case.



### NOTICE:

Shut off lights and power switches and remove all products from case. Allow sufficient time for the unit to reach room temperature before proceeding with cleaning.



### NOTICE:

Remove all products from case before proceeding with cleaning procedure.



### NOTICE:

Acrylic front air deflector requires special washing procedures to prevent hazing and yellowing of material.

**Note:** Detergents are not recommended and do not use abrasive cleaners or pads to prevent scratching of surfaces.

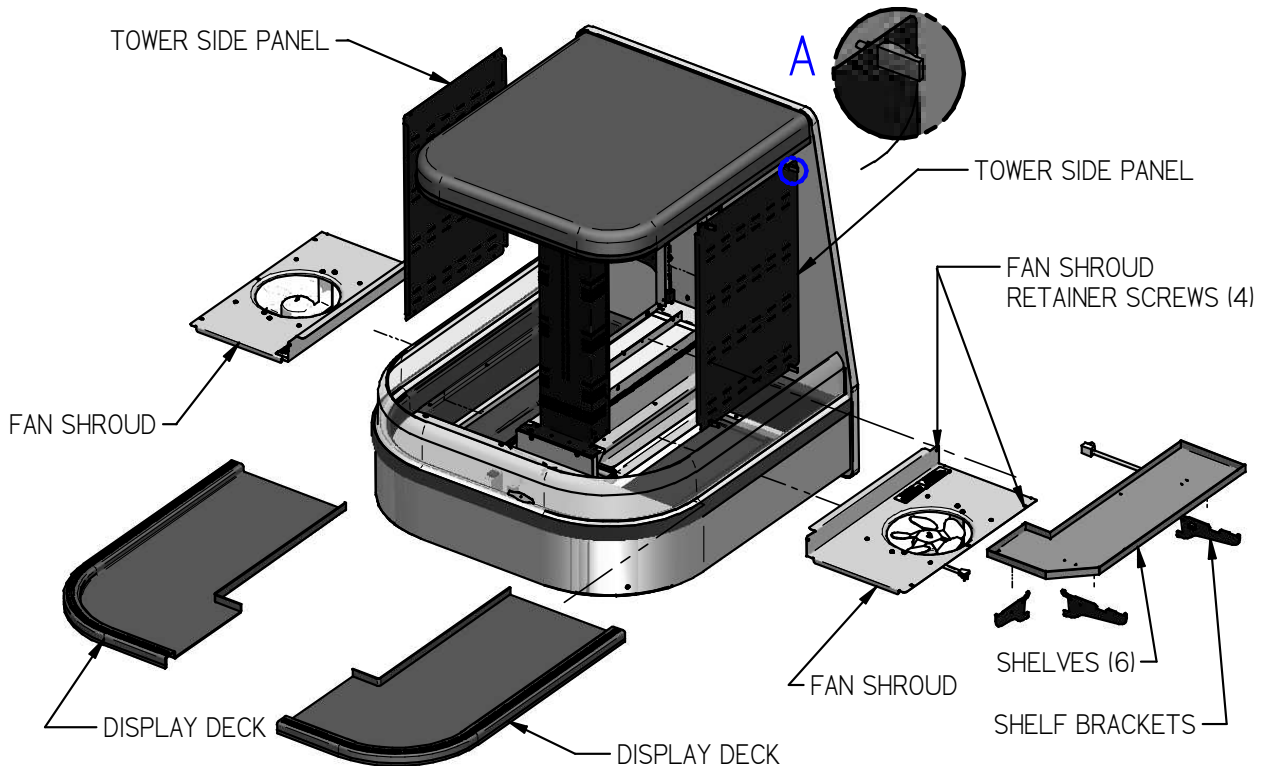

Remove interior shelving from unit as described in the “Shelving Installation and Removal” section of this manual.

1. Dip rag in warm soapy water and ring out thoroughly. Clean all shelves and shelf brackets and dry with soft dry towel.
2. Remove tower side panels by lifting (4) latch levers and pulling tower side panel out away from tower.

3. Dip rag in warm soapy water and ring out thoroughly. Clean the tower side panels and inside both tower ends. Dry with soft dry towel
4. Lift the display decks up and out of evaporator tub.
5. Remove the fan shroud assembly by removing (2) retaining screws from the outer flange and the (2) from the inner flange. Lift the fan shroud assembly and reach in and unplug the evaporator fan motor cord. Lift fan shroud assembly out of tub.
6. Clean the display deck(s) using warm soapy water and a brush. Rinse thoroughly and allow dry. Wipe off fan shroud assembly (do not rinse or submerge fan motors).
7. Clean the entire interior of the case using warm soapy water. Wipe off all soapy water with a damp cloth and allow to dry. (DO NOT use solvents such as Acetone, Benzene, Carbon Tetrachloride, and Lacquer Thinners)
- 8. IMPORTANT: Cleaning the clear acrylic plastic front air deflector requires special care to prevent hazing and yellowing of material. Clean as described in “Acrylic Air Deflector Cleaning” section of this manual.**
9. Reassemble all components in reverse order.

NOTE: Depending on the amount of usage and spillage of foreign material, some fasteners may have to be removed and parts disassembled to allow proper cleaning of the unit.

---

## SERVICE INFORMATION

---

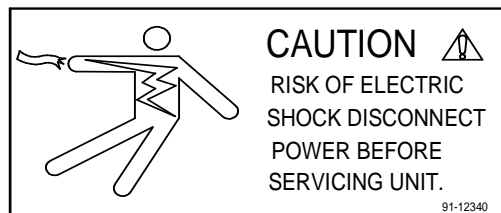

Before any service work is performed on the case, make sure all power is disconnected to the case.

Service problems or request for repair parts from authorized service agencies, trained service personnel, or owners should be referred to:

**TECHNICAL SERVICE DEPARTMENT**  
**Federal Industries**  
**P.O. Box 290**  
**Belleville, WI 53508**  
**Toll Free: (800) 356-4206 / WI Phone (608) 424-3331**  
**Fax: (608) 424-3234**

## **Pre-Service Checklist**

You may avoid the cost and inconvenience of an unnecessary service call by first reviewing this checklist of frequently encountered situations that can cause unsatisfactory case performance.



**CAUTION:** Before servicing case, turn off power at the main breaker of fuse box.

### ***Case Does Not Operate***

Check for disconnected power supply.  
Check for tripped breaker on blown fuse.  
Check that the thermostat display is on and that the green indicator light is lit.

### ***Lights Do Not Operate***

Check that power switch & light switch is on.  
Check for tripped breaker or blown fuse.  
Check that light housing cords are plugged in correctly to sockets in the tower

### ***Case Temperature Too Warm***

Check that the cold air inlet and outlet slots are not blocked.  
Check for a blocked or dirty condenser coil.  
Check for cold airflow. Lack of adequate cold airflow could indicate a defective evaporator fan or a blocked evaporator coil. Check that paper or foreign materials are not blocking evaporator. If the evaporator coil is blocked due to excessive frost, put into manual defrost. Excessive frost can buildup overtime if the case is set too cold or if there is excessive humidity in the store.  
Check all the fans in the evaporator compartment and tower are running.

### ***Case Sweating Note:*** Some interior sweating is normal on this case.

Check room ambient – Case is designed to operate in an environment not to exceed 75°F and 55% relative humidity.  
Check all the fans in the evaporator compartment and tower are running.

### ***Overflow of Condensate Pan***

Check that drain in bottom of tub floor is not plugged.  
Check that drain trap to the condensate pan is not plugged

### ***Overflow of Optional Condensate Pump:***

Check that drain in bottom of tub floor is not plugged.  
Check that drain trap to the condensate pan is not plugged  
Check that drain lines from pump is not plugged or pinched.  
Check to see that pump float is operating correctly.  
Verify that pump is plugged in and has power.  
Replace pump if still not pumping condensate.

## **Special Service Situations**

There are rare occasions when the refrigerant charge must be evacuated from a case in order to perform service work. In those situations, Federal Industries recommends that the refrigerant charge be evacuated into a recovery system to prevent the possibility of hydro-fluorocarbons (HFC's) from being released into the atmosphere.

The release of HFC's into the atmosphere is a potential source of global warming. Note the condensing unit that was supplied with this case has a receiver tank large enough to hold all the charge you maybe able to pump down the system when service is required.

If moisture or liquid is observed around or under a Federal Industries case, an immediate investigation should be made by qualified personnel to determine the source of the moisture or liquid. The investigation made should determine if the case is malfunctioning or if there is a simple housekeeping problem.

Moisture or liquid around or under a case is a potential slip /fall hazard for persons walking by or working in the general area of the case. Any case malfunction or housekeeping problem that creates a slip / fall hazard around or under a case should be corrected immediately.

---



---

# SALE & DISPOSAL

---



---

If you the owner sells or gives away this Federal Industries case it is the owner's responsibility to make sure that all safety labels and the Installation-Service Manual are included with it. If you need replacement labels or manuals, Federal Industries will provide them free of charge. Contact the customer service department at Federal Industries at (800) 356-4206.

The customer service department at Federal Industries should be contacted at the time of sale or disposal of your case so records may be kept of its new location.

If you sell or give away your Federal Industries case, you should evacuate the refrigerant charge before shipment. Federal Industries recommends that the charge be evacuated into a recovery system to prevent the possibility of HCFC's from being released into the atmosphere.

---



---

## REFRIGERATION & ELECTRICAL DATA

---



---

<b>Model</b>	<b>ECSS40SC/ECSS60SC</b>		<b>ECSS40R/ECSS60R</b>	
<b>REFRIGERATION CHARGE</b>	<b>6 Pounds (R-404A)</b>		<b>(R-404A)</b>	
<b>POWER SUPPLY, VOLTS</b>	<b>230 Volts</b>		<b>230 Volts</b>	
Frequency	60 Hertz		60 Hertz	
Phase	1 Phase		1 Phase	
Number of Wires	3		3	
	<b><u>AMPS</u></b>	<b><u>VOLTS</u></b>	<b><u>AMPS</u></b>	<b><u>VOLTS</u></b>
<b>Compressor</b>	<b>9.0 / 11.0</b>	230	-	-
<b>Condenser Fan</b>	2.6	230	-	-
<b>Base Fan</b>	-	-	.15	230
<b>Evaporator Fan Motor (EACH)</b>	0.15 ea.	230	0.15 ea.	230
<b>Lights Power Supply 12v</b>	.8	230	.8 ea	230
<b>Condensate Heater</b>	7.8	230v	7.8	230v
<b>Opt. Condensate Pump</b>	.75	240v	.75	240v

**Refer to the rating plate data attached to side of base for Maximum Fuse Size and Minimum Circuit Ampacity.**

---

---

# CONTROL OPERATION

---

---

## **Electronic Control**

This unit is equipped with an Invensys – Ranco model E72R temperature control. The control parameters are set at the factory and cannot be manually changed in the field. Control parameter changes can only be made by downloading a new set of parameters via a program chip supplied by Federal Industries. The pre set control parameters are listed on the chart in the Settings Chart below.

## **Operation**

The control uses two sensors, one located in the air stream and one located on the evaporator coil. The sensor located in the air stream is referred to as the temperature control sensor. The sensor located on the evaporator coil is referred to as the coil sensor.

The temperature control sensor is located inside the center tower at the top. The sensor location is critical for proper operation on the unit. Do not move or relocate this sensor.

The coil sensor is strapped to the evaporator coil. This sensor location is critical for proper operation of the unit. Do not move or relocate this sensor.

The temperature control is set to cut in at 41 degrees F. The Temp control cuts out at 13 degrees F at the coldest setting 'COLD' and 28 degrees F at the warmest setting, '1' on the control dial.

The temp control turns off the refrigeration system when the control is turned all the way counterclockwise.

## **Defrost Cycle**

The Ranco control is programmed to initiate defrost via two different methods. There are 3 programmed defrost cycles in the case which will initiate a defrost cycle every 8 hours. The unit does not have a time clock so the defrost cycles cannot be set for any specific time of day.

The unit also has an 'On demand' defrost feature that will initiate a defrost when the temperature differential between the evaporator temperature and the air temperature is more than 15 degrees for 5 minutes after 30 minutes into the refrigeration cycle.

## Control Factory Settings

The control parameters are set at the factory and cannot be manually changed in the field. Control parameter changes can only be made by downloading a new set of parameters via a program chip supplied by Federal Industries

**E3380**

AS OF:

11/10/11

TAB	REF	PARAMETER DESCRIPTION	FACTORY DEFAULT	ECSS40/60, IMSS60/84
CONFIGURATION	1	Controller Operation Temperature Units	Fahrenheit	°F
	4	Defrost Termination Method	Evaporator Sensor	Evaporator Sensor
SET-POINTS	8	Cut-In Warm	14°F	41°F
	9	Cut-Out Warm	-4°F	<b>28°F</b>
	10	Cut-In Cold	-2°F	41°F
	11	Cut-Out Cold		<b>13°F</b>
	13	Comp Minimum On Time	1 min	<b>5 min 0 sec</b>
DISPLAY	15	Defrost Display Lock (display indication during defrost)	Lock Display at Temp. reading prior to defrost.	SHOW CURRENT TEMPERATURE
DEFROST	38	Defrost Termination Temperature	41°F	43°F
	39	Time to First Defrost (hh:mm)	6 hr	8 hr
	40	Time to subsequent Defrost	6 hr	8 hr
	41	Defrost Max Duration	1 hr	30 min

## **Control Display**

The control display is located in the unit base. It is programmed to display the current temperature from the control sensor located inside the center tower at the top.

## **Maximum Run Timer**

The unit is equipped with a maximum run timer that is preset at the factory for 60 minutes on and 10 minutes off. If the temperature control does not reach cut out set point after running for one hour, the timer will turn the compressor off for 10 minutes.

---

---

# REFRIGERATION OPERATION

---

---

## **Self Contained Models**

Refrigeration R404 Charge	<b>6 Pounds</b>

The self-contained models are shipped from the factory with a completely operational 404A refrigeration system and require no modifications or adjustments upon installation. Case must be installed as per the installation section of this manual to provide proper condensing air cooling.

### **Self Contained Refrigeration Operation**

The unit temperature is controlled by the Electronic control and timers outlined in the control section of this manual.

Note: The condenser fan runs continuously.

**Remote Models** Use pressure gauges to set pressure control.

Refrigeration R404 Charge	<b>CHARGED IN FIELD</b>
Remote Low Press. Switch Cut In	50 psi
Remote Low Press. Switch Cut Out	15 psi
Adjustable Head Master	200 psi
Remote High Press. Switch Cut Out	400 psi

The remote models are designed to use 404A refrigerant and shipped from the factory with the evaporator coil, expansion valve, sight glass and refrigerant solenoid valve. Drier filter must be installed in field for proper operation. Electronic control runs identical to the Self Contained models except the electronic control opens and closes a refrigeration solenoid valve located on the suction line instead of turning on and off a compressor. The solenoid valve closes and shuts

off the refrigeration flow to the unit and initiates a pump down cycle. This will allow the remote low pressure switch to open and shut off remote compressor.

The condensing unit and pressure controls are optionally supplied from the factory for remote location installation. The condensing unit must be mounted and wired by the installer. The high low pressure switch must be wired in series with the compressor power supply as shown in diagram below.

1. Mount condensing unit indoors as close to the remote display case as practical. The refrigeration line should be as short as possible and must not exceed 30 feet.
2. All refrigeration and/or electrical materials between the condensing unit and display case are to be supplied by installing contractor.
3. Route properly sized and designed refrigeration lines from the condensing unit to the cabinet. Horizontal suction lines should be pitched downward towards the condensing unit at least 1/2" per 10' run to aid the oil drainage. A "P" trap must be installed in the suction line at the foot of every riser to insure oil return. Dry nitrogen must be used to flow through tubing while brazing refrigeration lines.
4. Suction line must be insulated the entire length with Armaflex (or equivalent). Do not run liquid line inside insulation with suction line.
5. The remote high/low-pressure control must be mounted, wired and set pressures by the installer.
6. Leak check condensing unit, cabinet, and all connecting tubing. Cabinet and condensing unit tubing should be checked to insure no leaks occurred during shipping or from rough handling.

Make certain all refrigeration valves are opened and evacuate system to 500 microns. Charge the system with refrigerant type specified on the data plates.

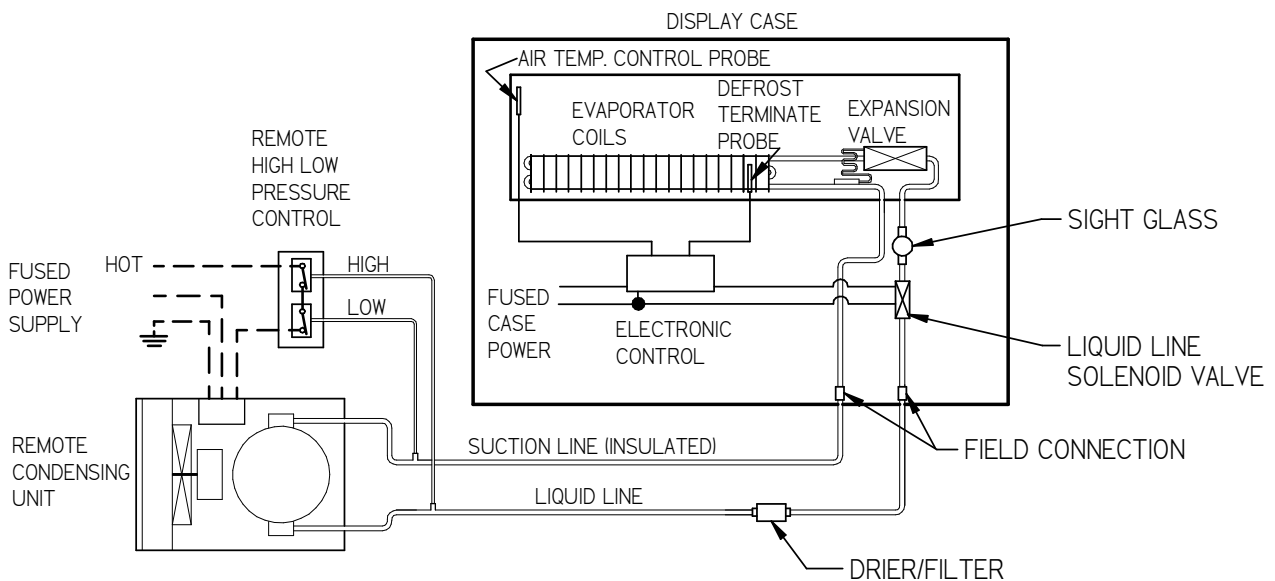

# PARTS LIST

## REPLACEMENT PARTS

<b>Refrigeration System</b>	ECSS40	ECSS60
Condensing Unit Copeland (Self Contained)	30-19128	30-19025
Condensing Unit Tecumseh (Self Contained)	30-17889	-
High/Low Pressure Control	32-51009	32-51009
Evaporator Coil Left/ Right	33-18810-L/33-18810-R	33-19285-L/33-19285-R
Expansion Valve TXV	32-19408	32-19408
Sight Glass	32-54011	32-54011
Refrigerant Filter/Drier	32-19067	32-19067
Refrigeration Solenoid Valve (Remote)	32-14325	32-14325
Refrigeration Solenoid Valve COIL (Remote)	41-14324	41-14324
Motor Evaporator Fan	41-19070	41-19070
Wire Harness Evaporator Motor	43-19083	43-19083
Blade Evaporator Fan	72-12254	72-12254
Guard Evaporator Fan	64-18015	64-18015
<b>Electrical Components</b>		
LED Shelf & Top Light Bar (8)	42-19038-1	42-19038
LED Top Light Bar, Front (1)	42-19038-2	42-19038-2
Shelf Lamp Cord	43-19061-1	43-19061-1
Shelf Lamp Socket	43-19060-1	43-19060-1
Light power Supply 12V	39-19039	39-19039
Power Switch	41-13733	41-13733
Light Switch	41-11066	41-11066
Temp Control (Before 5/23/12)	32-19027	32-19027
Temp Control Display (Before 5/23/12)	32-19092	32-19092
Temp Control (After 5/23/12)	32-19445-3	32-19445-3
Temp Control Display (After 5/23/12)	32-19446	32-19446
Ribbon Cable display	32-19093	32-19093
Probe Temp (2)	32-19094	32-19094
Timer, Max Run (Before 5/23/12)	41-17324	41-17324
Condensate Pan Ass'y	SA4889-1	SA4889-1
Heater Condensate Pan	40-17861	40-17861
Condensate evap pan	47-12963	47-12963
HighTemp Safety Ass'y	SA-1880	SA-1880
Float Switch condensate Pan	41-13022	41-13022
Float Condensate Pan	SA2928	SA2928
Optional Power Cord	43-19090	43-19090
Optional Condensate Pump	47-18980	47-18980
<b>Miscellaneous Components</b>		
Display Deck Plastic Left/Right	15-18857-L/ 15-18857-R	15-19293-L/ 15-19293-R
Fastener Pad Set Display Deck	77-17848/77-17849	77-17848/77-17849
Metal Shelf (SHELF ONLY)	SA4737-L/SA4737-R	SA5048-L/SA5048-R
Air Diffuser Air Discharge	W11533-2	W11533-4
Shelf Bracket Long	67-18727	67-18727
Shelf Bracket Short	67-18727-1	67-18727-1
Clip Shelf Cord Retainer	81-30618	81-30618
Thermometer	32-13662	32-13662
Acrylic Air Deflector Seal	64-19068	64-19068











# Self Contained ECSS40 SC Copeland AFTER 5/23/12 NO LONGER USED AFTER 1/21/13

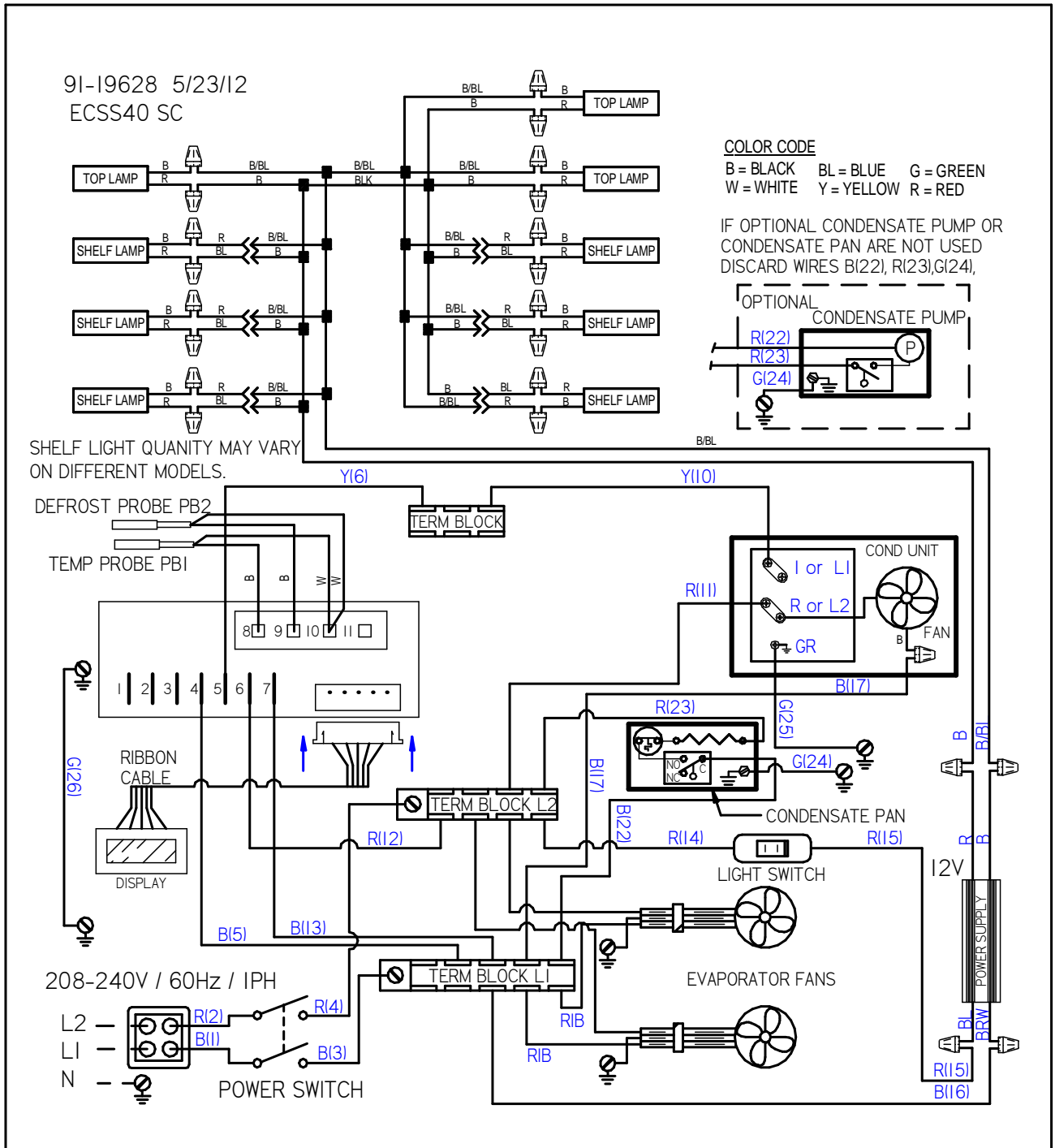

# Self Contained ECSS40 SC Tecumseh AFTER 5/23/12 STANDARD AFTER 1/21/13

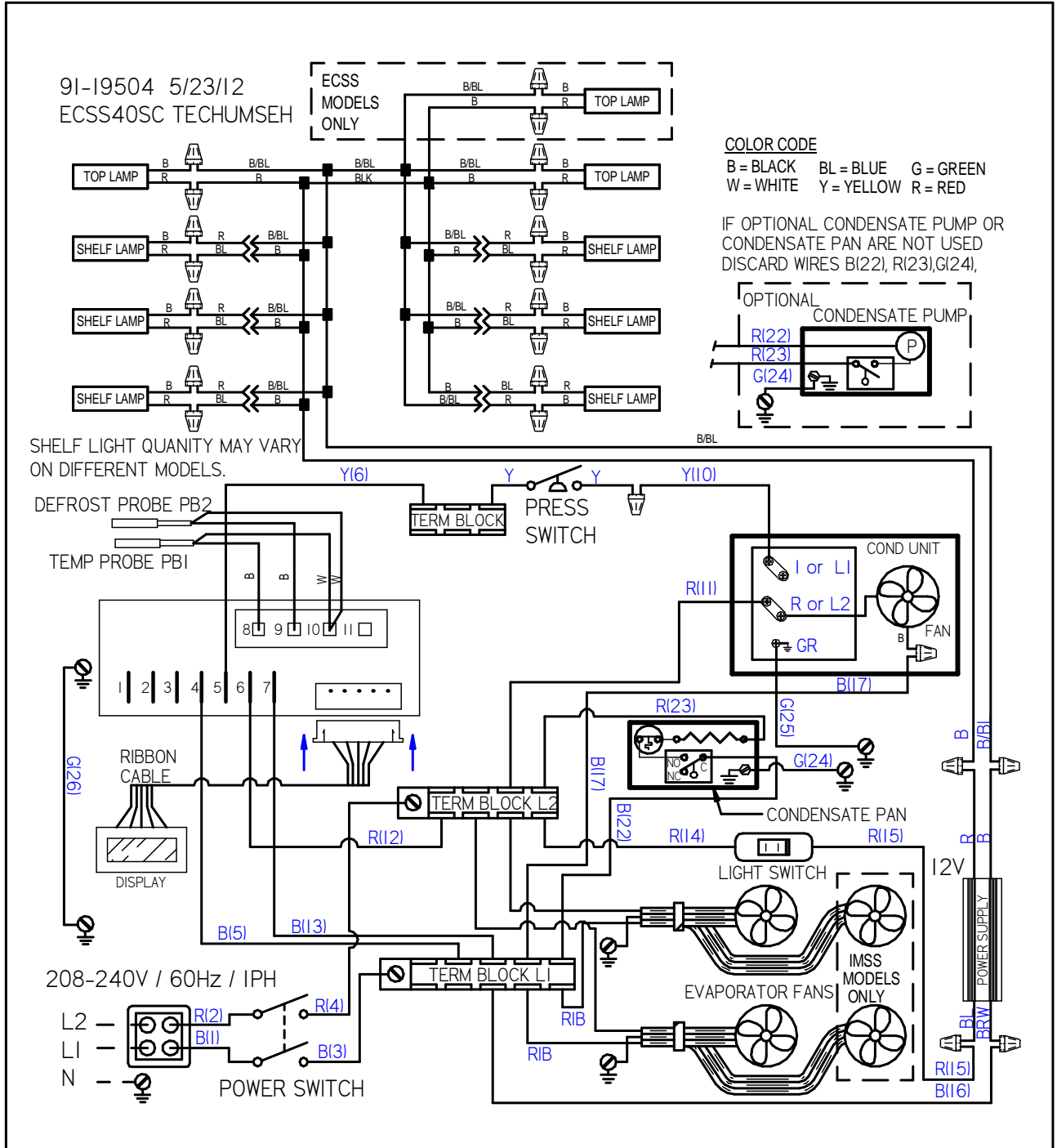



# Remote ECSS40R AFTER 5/23/12

