

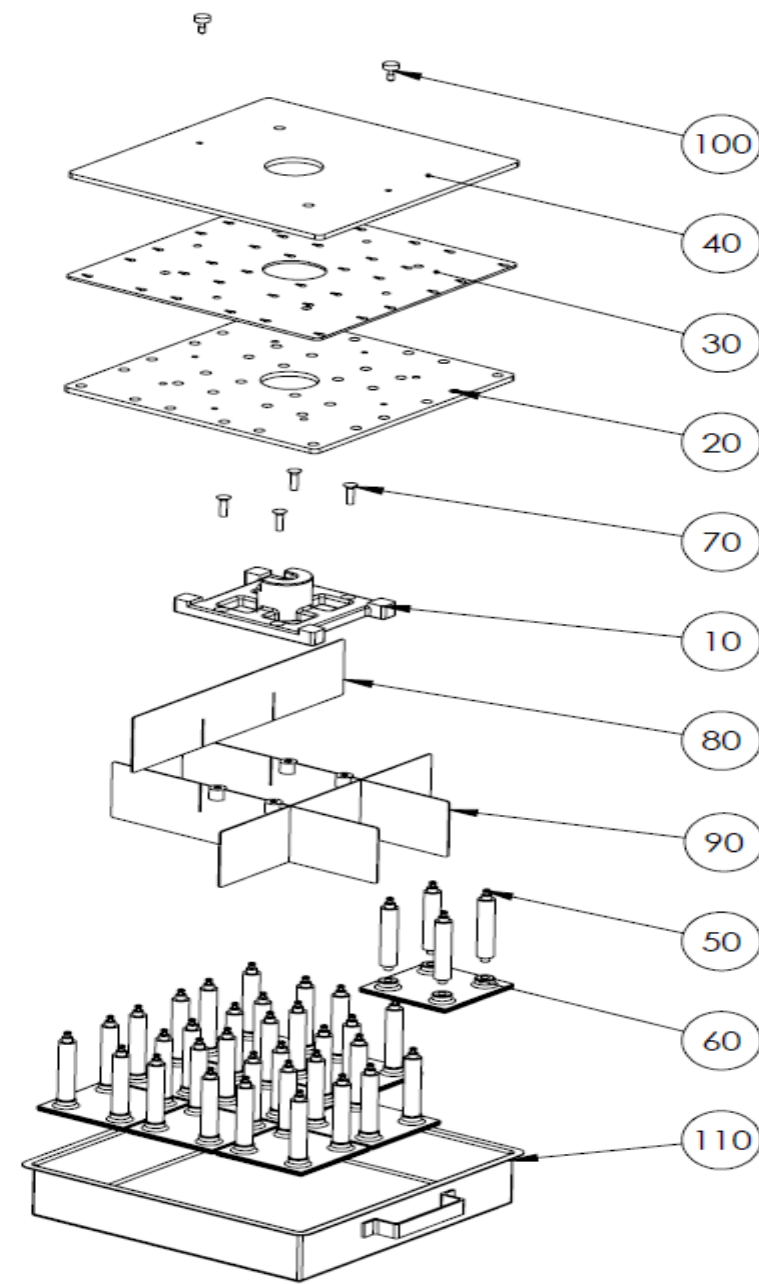

Dutchess

Bakers Machinery Company, Inc.

Made in the USA—Superior, Wisconsin



Item	Qty.	Description	Part Number
10	1	9-PART SQUARE HEAD DIVIDER PLATE	B4-147-004312
20	1	9-PART SQUARE HEAD PLUG PLATE	B4-147-004310
30	1	9-PART SQUARE HEAD LOCK PLATE	B4-147-004297
40	1	9-PART SQUARE HEAD COVER PLATE	B4-147-004299
50	36	STEM, PLUG, 36 & 9-PART	B4-054-0003
60	9	9-PART SQUARE HEAD PLUG	A4-139-004303
70	4	FLAT HD PH MACH SCR	22-E-0408
80	2	9-PART SQUARE HEAD DIVIDER KNIFE	B4-141-004306
90	2	9-PART SQUARE HEAD DIVIDER WELDMENT	B4-141-004308
100	2	CAPTURED SCREW	P4-927-0001

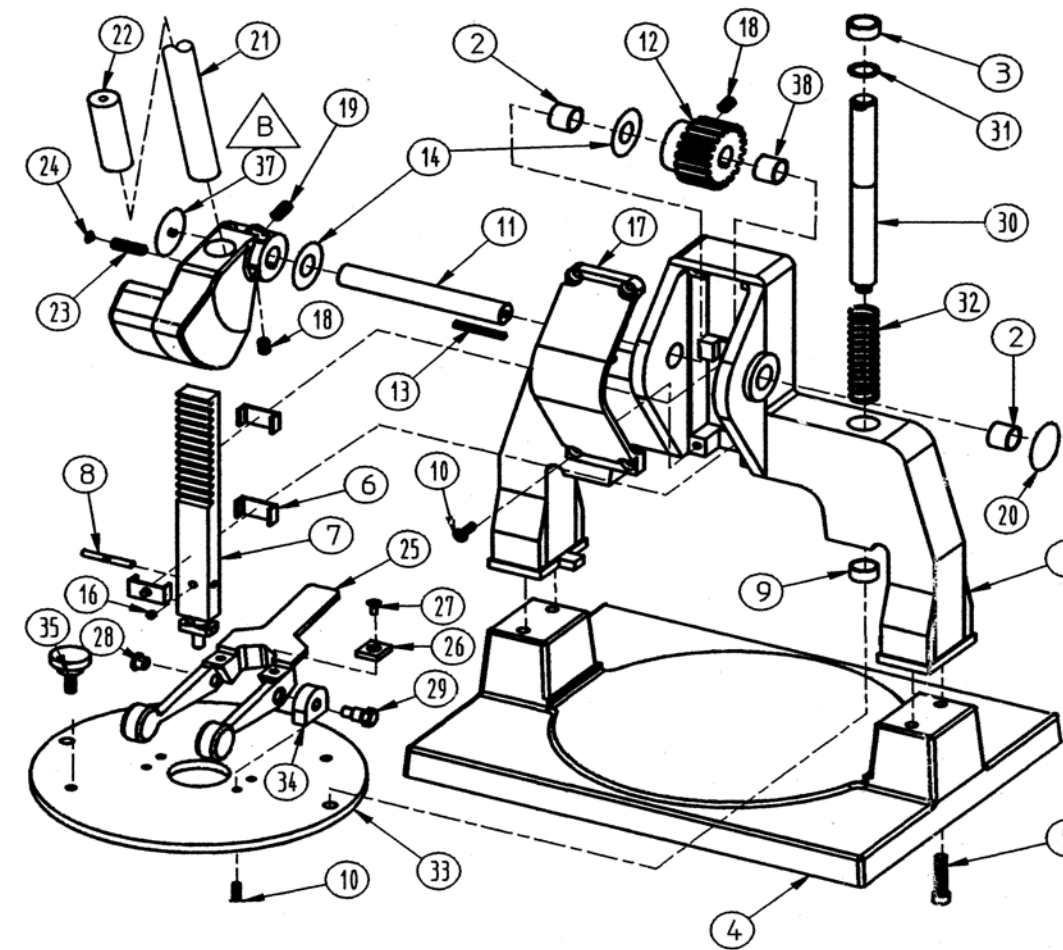

Item	Qty	Description	Part Number	Item	Qty	Description	Part Number
1	1	Yoke	C4-088-0001-P	20	1	Cover	A4-063-0002
2	2	Bushing	P4-909-0001	21	1	Handle	A4-092-0001
3	2	Bushing	P4-909-0003	22	1	Hand Grip	P4-939-0001
4	1	Base	C4-030-0001-P	23	1	Socket Set Screw	29-Y-0610
5	4	Capscrew	12-E-0608	24	3	Set Screw Plug	A4-139-0007
6	3	Bushing Half	A4-024-0001	25	1	Trip Lever	B4-045-0004-P
7	1	Ram with Rack	B4-003-0003	26	2	Wear Plate	A4-147-0006-P
8	1	Ram Pin	A4-066-0001	27	2	Screw	22-E-0304
9	2	Bushing	P4-909-0002	28	2	Bushing	P4-909-0005
10	4	Screw	22-E-0407	29	2	Pivot Bolt	A4-033-0001
11	1	Gear Shaft	A4-053-0003	30	2	Spindle	A4-145-0001
12	1	Gear	A4-003-0002	31	2	Retaining Ring	P4-957-0001
13	2	Key	S-L-03-03-16	32	2	Spindle Spring	A4-082-0002
14	2	Spacer	A4-023-0002	33	1	Trip Plate	C4-147-0005-P
15	1	Lever w/Counterweight	B4-045-0001-P2	34	2	Pivot Tab	A4-146-0001-P
16	1	Slotted Set Screw	31-E-0402	35	2	Knob	P4-939-0002
17	1	Yoke Cover	B4-063-0119	37	1	Plug	A4-139-0024
18	2	Socket Set Screw	29-Y-0605	38	1	Bushing	P4-909-0031
19	1	Socket Set Screw	29-Y-0607	39	4	Yoke Cover Screw	22-E-0406

MODEL BMIH-9SQ MANUAL DOUGH DIVIDER

The Dutchess BMIH Dough Divider is simple to operate and very accurate. The removable divider head assembly can be cleaned daily by hand in a sink or dish washer. Instructions for removal of the divider assembly are found inside this manual. Removal takes only seconds and without the need for tools.

This Dough Divider will divide a single large pre-weighed piece of dough into 9 equal size pieces, the weight of each piece being determined by the weight of the large pre-weighed piece placed into the pan initially.

DOUGH DIVIDING PROCEDURE

A simple formula for determining the size of the initial piece of dough is to decide what each finished piece should weigh. Multiply this weight by 9, then divide by 16 (ounces), and you will have the weight in pounds and ounces of the initial piece of dough needed to be placed into the pan.

Example: Each piece needs to weigh 20 ounces. 20 ounces x 9 (pieces) = 180 ounces
180 (ounces) ÷ 16 (ounces) = 11lbs., 4 ounces.

(See Dough Weight Chart on back for additional examples)

Operating Instructions

Step 1: Place the large dough piece to be divided into a lightly dusted Pan, then place the Pan into the Machine. **Note:** Before placing the Pan into the Machine, press the dough by hand so it completely covers the bottom of the pan. It works best to form the large piece of dough into a square shape prior to placing into the pan.

Step 2: After placing the Pan into the Machine, pull down on the Operating Handle and exert a firm pressure for 3-4 seconds. This will uniformly flatten the dough inside the Pan.

Step 3: Slightly relax the pressure on the Operating Handle and then push down on the Trip Lever to release the Cutting Knives from the Head Assembly. Next, push the Operating Handle all the way down and the Knives will cut the dough into evenly divided pieces.

Raise the Operating Handle to the start position, remove the Pan and dump the divided dough pieces. You are now ready to repeat the procedure.

Tip: For sticky dough products, line the bottom of the Pan with a square piece of parchment paper. The paper can be used repeatedly.



S
T
E
P
1

S
T
E
P
2

S
T
E
P
3

9-Square Divisions

Weight of dough piece
to be placed into Pan
for dividing Equals 9 pieces
each weighing

2 lbs., 13 oz. (1260 gr)	-	5 oz. (142 gr)
3 lbs., 6 oz. (1512 gr)	-	6 oz. (170 gr)
3 lbs., 15 oz. (1764 gr)	-	7 oz. (198gr)
4 lbs., 8 oz. (2016 gr)	-	8 oz. (227 gr)
5 lbs., 1 oz. (2268 gr)	-	9 oz. (255 gr)
5 lbs., 10 oz. (2520 gr)	-	10 oz. (283 gr)
6 lbs., 3 oz. (2772 gr)	-	11 oz. (312 gr)
6 lbs., 12 oz. (3024 gr)	-	12 oz. (340 gr)
7 lbs., 5 oz. (3276 gr)	-	13 oz. (368 gr)
7 lbs., 14 oz. (3528 gr)	-	14 oz. (397 gr)

9-Square Divisions

Weight of dough piece
to be placed into Pan
for dividing Equals 9 pieces
each weighing

8 lbs., 7 oz. (3780 gr)	-	15 oz. (425 gr)
9 lbs. (4032 gr)	-	16 oz. (453gr)
9 lbs. 9 oz. (4284 gr)	-	17 oz. (476 gr)
10 lbs., 2 oz. (4536 gr)	-	18 oz. (504 gr)
10 lbs., 11 oz. (4788 gr)	-	19 oz. (532 gr)
11 lbs., 4 oz. (5040 gr)	-	20 oz. (560 gr)
11 lbs., 13 oz. (5292 gr)	-	21 oz. (588 gr)
12 lbs., 6 oz. (5544 gr)	-	22 oz. (616 gr)
12 lbs., 15 oz. (5796 gr)	-	23 oz. (644 gr)

Dough weight capacity may increase or decrease according to dough formulation,
viscosity and/or bench rest time.

Interchangeable / Removable Head Assembly—No Tools Required

Model BMIH-9SQ — SPECIFICATIONS

Cuts	9 Pieces (Square)
Range	9-part (5 oz up to 23 oz (142 gr to 644 gr))
Machine Dimensions	14"D x 18-1/2" W x 21-1/4" H
Boxed Dimensions	15-3/4"D x 19-1/2" W x 25-1/2"H
Machine Weight (with one head)	83 lbs. (37.65 kg)

Unit comes equipped with one Stainless Steel Pan.

Additional Pans and Portable Stand are available.

Additional Pans . . . Part # B4-149-004316 ~ Portable Stand . . . Part # B4-436-0072

Also available are Optional Round Divider Head Assemblies in 36, 18 & 9-Part
Specify IH-36, IH-18, IH-9 (Note: Must also order a round Stainless Steel Pan, p/n [B4-149-0001](#))



Fig 1: Completely loosen both Black Knobs. Leave pan on the Base for the removal and installation. The pan will assist in the removal and installation.



Fig 2: Push downward on the Trip Lever, then pull down on the Operating Handle. This will allow the Head to separate from the Trip Plate.



Fig 3: With the Head resting in the Pan (not shown) and the Handle in the down position, pull the Head & Pan towards you until it stops. You can now raise the Handle and remove the Head for cleaning.



Fig 4: To completely disassemble the Head, begin by removing the two Captured Screws and lifting off the Cover Plate. Note the position of the Captured Screws as they relate to the center of the Head when reassembling.

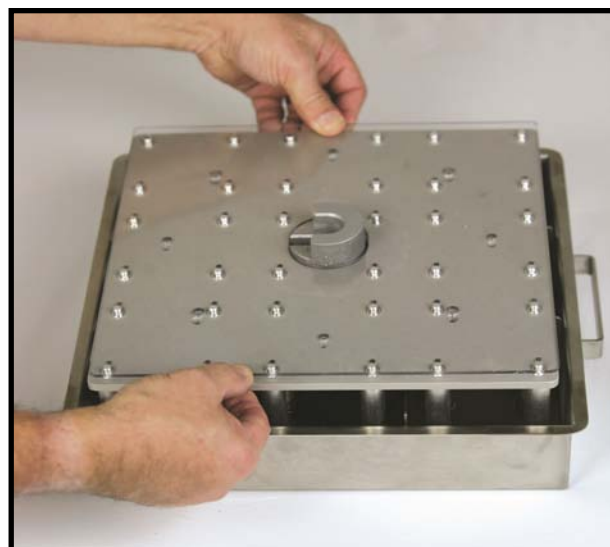

Fig 5: Slide the Lock Plate in the direction to allow the Stem tops to move to the opposite end of the key hole slots then remove the Lock Plate.

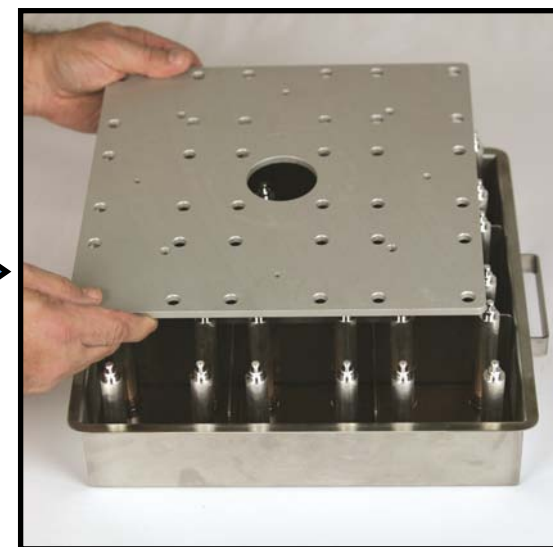

Fig 6: Now lift the Plug Plate exposing the Dividers and Divider Plate. No further disassembly is required beyond this point.

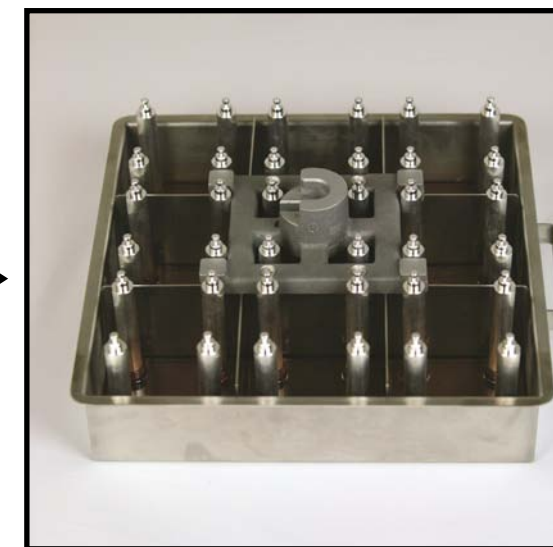

Fig 7: Shown in Pan are the Plugs w/Stems and the Divider w/Divider Plate attached. At this point parts can be removed for washing.



Fig 8

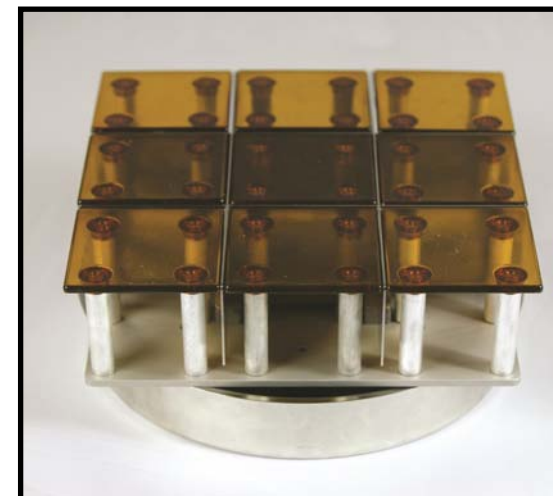

Fig 9



Fig 10

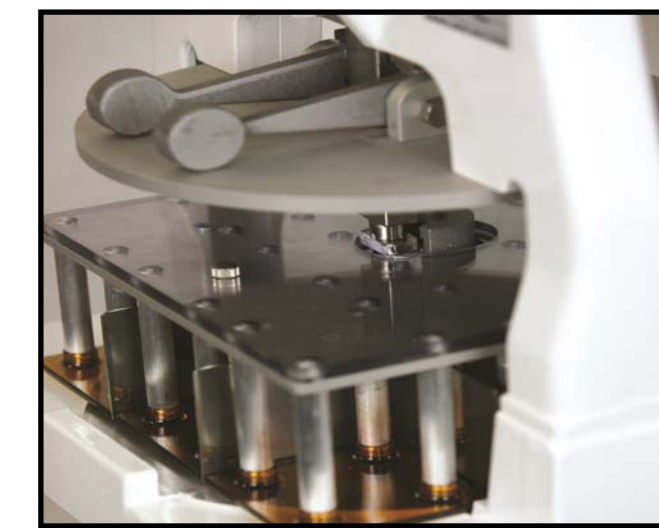

Fig 11

TO REASSEMBLE / INSTALL HEAD ASSEMBLY

Step 1: Place the Plug Plate on top of a pan such as a cake pan at least 10" in diameter. Next place the Knives with the Divider plate upside down as shown in Fig 8.

Step 2: Place all 9 Plugs with Stems in the Knives as shown in Fig 9. **Note:** You may have to tap firmly on the Plugs until the Stems snap into place in the Plug Plate and the face of the Plugs are flush with the Knives. See Fig 9.

Step 3: Place the Pan over the Knives and Plugs as shown in Fig 10. Then grasp the entire Pan and the Plug Plate, flip it over and set on the Bench. To complete the reassembly and installation of the Head follow the instructions in Figures 1 thru 5 in reverse order. See Fig 11 for final attachment.