



Your Solutions Partner

Installation and Operation Manual

Modular Production Center

RBD-60-TC4

RBD-60-CP4

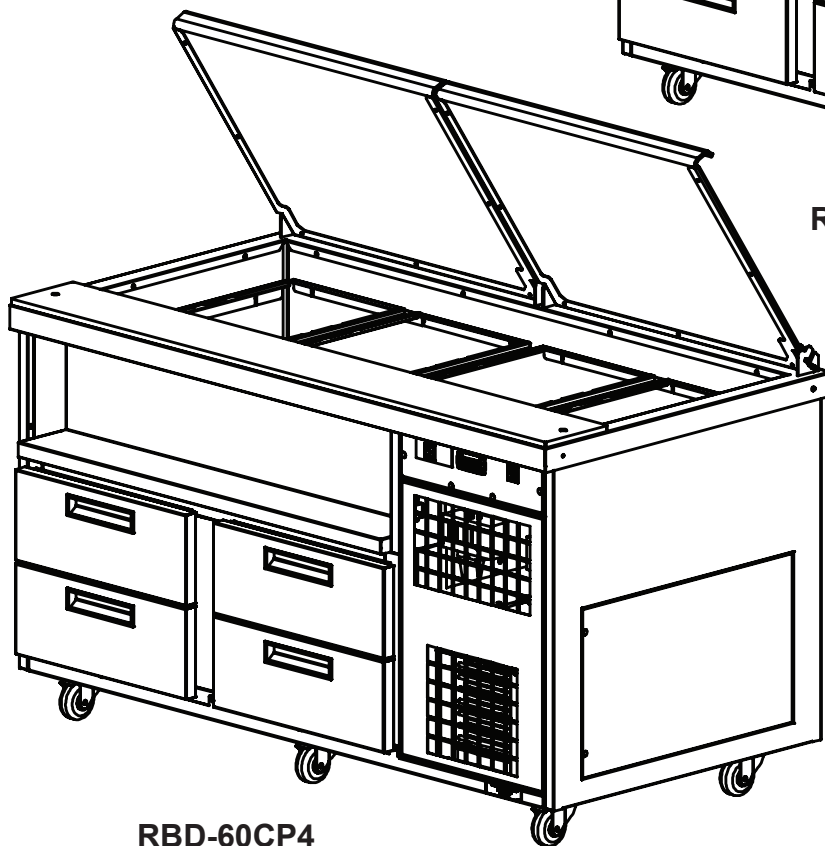
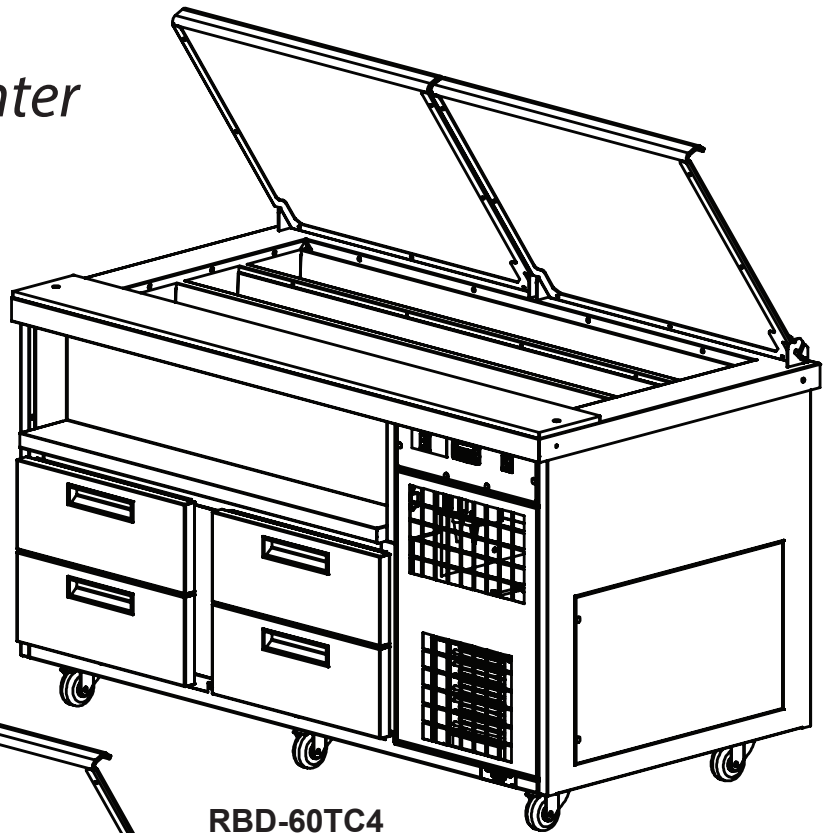

RBD-60CP4

CAUTION: Please read this manual completely before attempting to install, operate or service this equipment

*This manual is Copyright © 2018 Duke Manufacturing Co. All rights reserved.
Reproduction without written permission is prohibited. Duke is a registered
trademark of the Duke Manufacturing Co.*

P/N 529120
REV A Date 08/01/2018



TABLE OF CONTENTS

Important Safety Instructions.....	2
Critical Daily Startup Guide	4
Specifications.....	6
Installation	7
Operation.....	8
Cleaning and Maintenance.....	9
Wire Diagram	10

IMPORTANT SAFETY INSTRUCTIONS

Throughout this manual, you will find the following safety words and symbols that signify important safety issues with regards to operating or maintaining the equipment.



Indicates a hazardous situation which, if not avoided, could result in death or serious injury.



Indicates a hazardous situation which, if not avoided, could result in minor or moderate injury.



Indicates Important Information



Indicates electrical shock hazard which, if not avoided, could result in death or serious injury and/or equipment damage.



Indicates hot surface which, if not avoided, could result in minor or moderate injury.

In addition to the warnings and cautions in this manual, use the following guidelines for safe operation of the unit.

- Read all instructions before using equipment.
- For your safety, the equipment is furnished with a properly grounded cord connector. Do not attempt to remove or disconnect the grounded connector.
- Install or locate the equipment only for its intended use as described in this manual.
- Do not use corrosive chemicals on this equipment.
- Do not operate this equipment if it has a damaged cord or plug, if it is not working properly, or if it has been damaged or dropped.
- This equipment should be serviced by qualified personnel only. Contact the nearest Duke authorized service facility for adjustment or repair.
- Do not block or cover any openings on the unit.
- Do not immerse cord or plug in water.
- Keep cord away from heated surfaces.
- Do not allow cord to hang over edge of table or counter.

The following warnings and cautions appear throughout this manual and should be carefully observed.

- Turn the unit off, disconnect the power source and allow unit to cool down before performing any service or maintenance on the unit.
- The procedures in this manual may include the use of chemical products. You must read the Material Safety Data Sheets before using any of these products.
- The unit should be grounded according to local electrical codes to prevent the possibility of electrical shock. It requires a grounded receptacle with dedicated electrical lines, protected by fuses or circuit breaker of the proper rating, in accordance with all applicable regulations.
- Disposal of the unit must be in accordance with local environmental codes and/or any other applicable codes.
- This appliance is not intended for use by persons (including children) with reduced physical, sensory or mental capabilities, or lack of experience and knowledge, unless they have been given supervision or instruction concerning use of the appliance by a person responsible for their safety.

INSTALLATION

WARNING

This equipment is to be installed to comply with applicable Federal, State or Local Plumbing Code.

DRAIN CONNECTION:

The unit is designed to be used with or without a drain hook-up. The drain is supplied with a hose attached for use with a bucket, or may be hooked up to a floor or sink drain. Consult local codes as to the type of drain hook-up required in your area.

WARNING

The Refrigerated Counter Top is designed to hold pre-chilled products at suitable serving temperature. It is **not** designed to chill products or store them for long periods of time. Due to the variety of food products served from the refrigerated counter top, they should be stirred periodically to maintain consistent temperature. Foods that are not stirred periodically can become too warm on the top surface and freeze at the bottom. Prior to use, the unit should be turned on to lower the pan temperature before the chilled product is set in place. The unit should shut down daily for defrosting and cleaning.

CAUTION

ELECTRICAL CONNECTIONS:

The unit is designed to be operated on one (1) 15 amp dedicated circuit. The unit must be grounded. The receptacle, wired circuit, and protection should meet the required local codes for proper operation. If the supply cord is damaged, it must be replaced by the manufacturer, its service agent or an authorized service company in order to avoid a hazard.

OPERATION

UNIT CONTROLS AND OPERATION

Refrigerated Counter Top Operation

- The refrigerated counter top needs to be pre-chilled for 45 minutes before product is loaded. **Turn the power switch to the on position.**
- The refrigerated counter top is designed to hold pre-chilled (33 °F to 40 °F) product. Do not place warm product (above 40°F) in the refrigerated counter top as it is not designed to reduce the temperature of the product.
- All products must be removed from the refrigerated counter top at the end of the day and the refrigerated counter top must be turned off. **Wipe down all contact surfaces.** (See general cleaning instructions).
- Make sure any moving or hot air is blocked from any refrigerated counter top.

Refrigerated Drawer Operation

- The refrigerated drawers should be pre-chilled for 30 minutes before product is loaded.
- The drawers are design to hold pre-chilled (33 °F to 40 °F) product. Do not place warm product (above 40 °F) in the drawers as they are not designed to reduce the temperature of the product.
- Since the drawers are a sealed refrigerator, product can be left over night. **Never exceed the refrigerated hold times on any product, for food safety.**

NOTE: Refrigerated Counter Top units that have Cold Pans installed are all pressure control. The thermostat has been removed.

Pressure Control

The pressure control is set at the factory for optimized settings that work in all ambient temperatures. Adjusting is not recommended unless the manufacture suggests. If Cold Pan appears to require an adjustment to the control settings please contact authorized service agent.

WARNING

Field adjustment of the “differential” setting must not be made by other than qualified refrigeration service personnel.

Unauthorized tampering with the “differential” setting may void the warranty on this equipment.

Controls

Your mechanical cold pan has been preset in the factory to satisfy most applications. Due to conditions which may exist in your operation, you should not need to adjust the pressure control on your unit for colder or warmer temperature. The pressure control is located behind the louvered grill in the compressor compartment. Normally, the pressure control set point & differential are marked on control as factory settings. It is possible to adjust the temperatures for special cases but it is recommend to contact an authorized service agent prior to field adjustments to controls.

CRITICAL DAILY STARTUP GUIDE

(Keep for future use & training)

Verify drawers are closed

Turn on MASTER SWITCH. **NOTE:** Supplies power to both, drawers and counter top.

- Counter top LED light will turn on.
- Drawer refrigeration will turn on. **Do not adjust control.** *Factory Setting 34°*
-  Allow **30** minutes before opening drawers and adding food.

Verify counter top cover is closed

Turn switch to "ON" position to cool the counter top. **Do not adjust control.** *Factory Setting 38°*

-  Allow 45 minutes before opening cover and adding food.

Note: It is normal for display temperatures to read **below** freezing while keeping food between 33°F to 40°F. Adjustments are rarely needed. Refer to operation section of manual to make adjustments

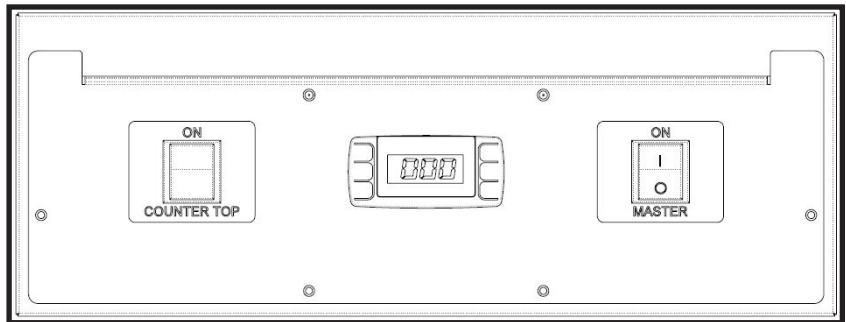

Make sure counter top is **ALWAYS** full of pans while **cover is open**.

Empty Spaces

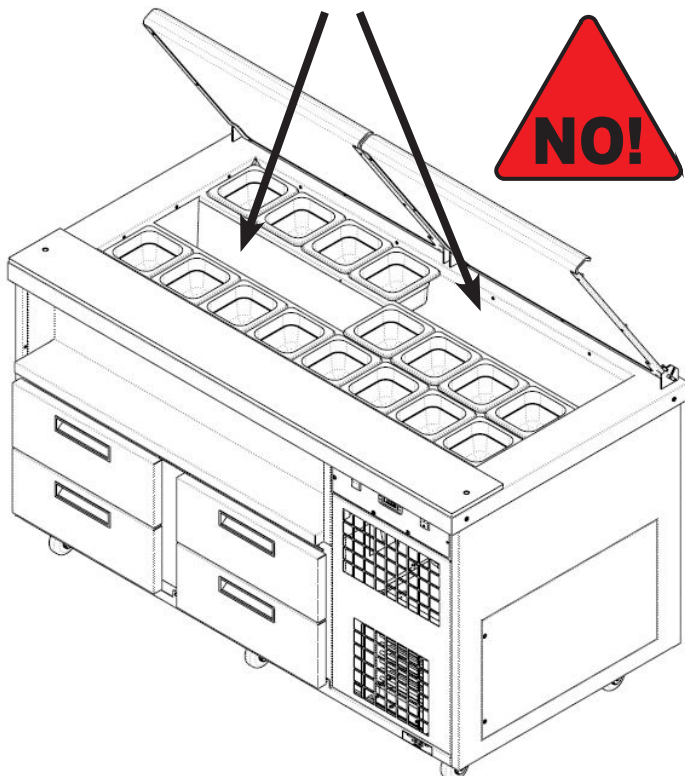

FULL

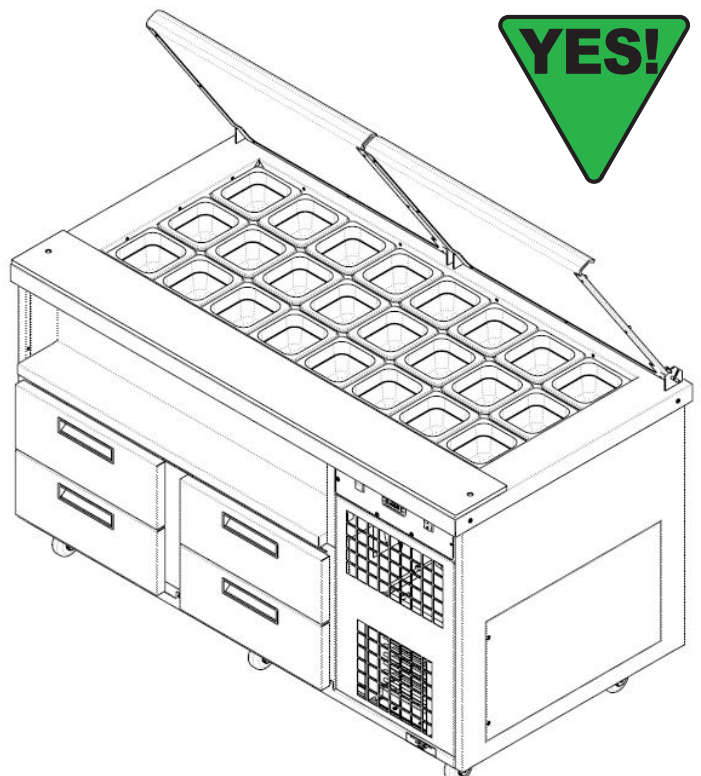

CRITICAL DAILY SHUT-DOWN GUIDE

(Keep for future use & training)

The counter top should be defrosted and cleaned every day.

Leave MASTER switch ON.

Verify counter top has been emptied of all food

Turn COUNTER TOP switch to OFF position to defrost the counter top.

- A. ⌚ Allow 30 minutes before cleaning. Make sure to remove all ice or water with paper towel.

Turn COUNTER TOP switch back ON.

- B. Close cover and ⌚ Allow at least 45 minutes before opening cover and adding food.

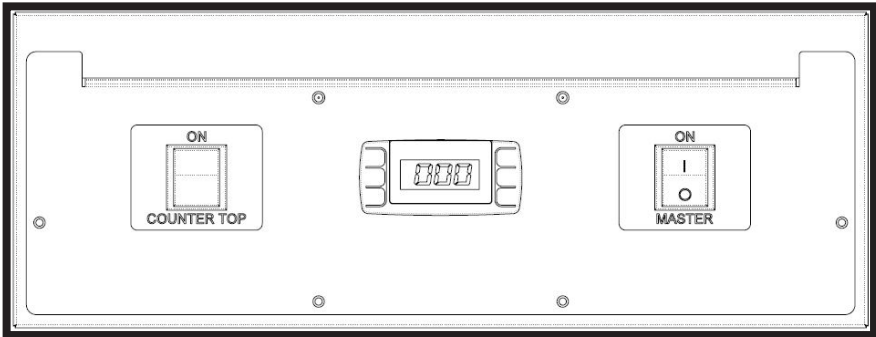

Defrosting/Cleaning

Cooling down for use

Open cover

No pans clean and dry

45 Minutes

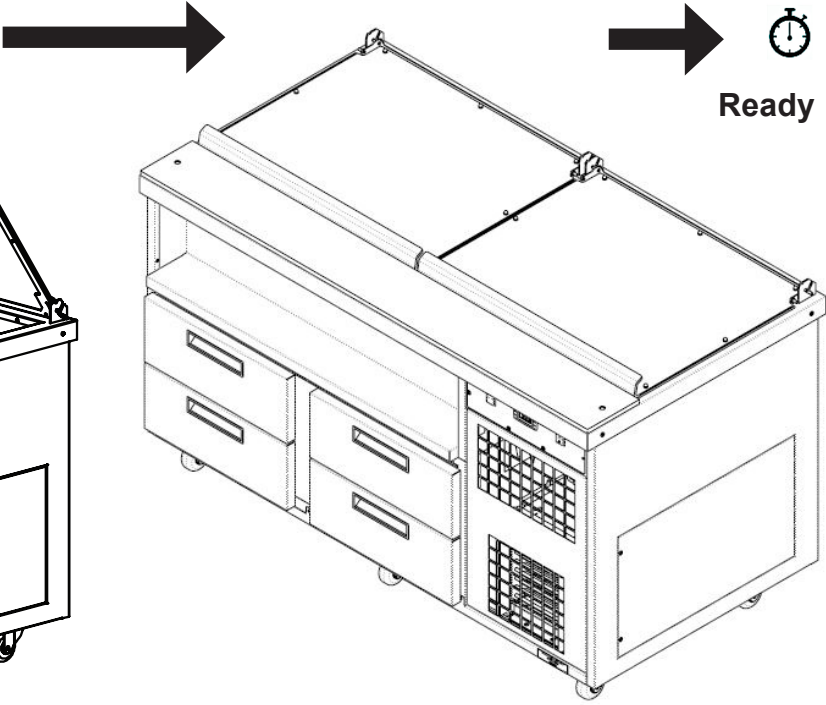
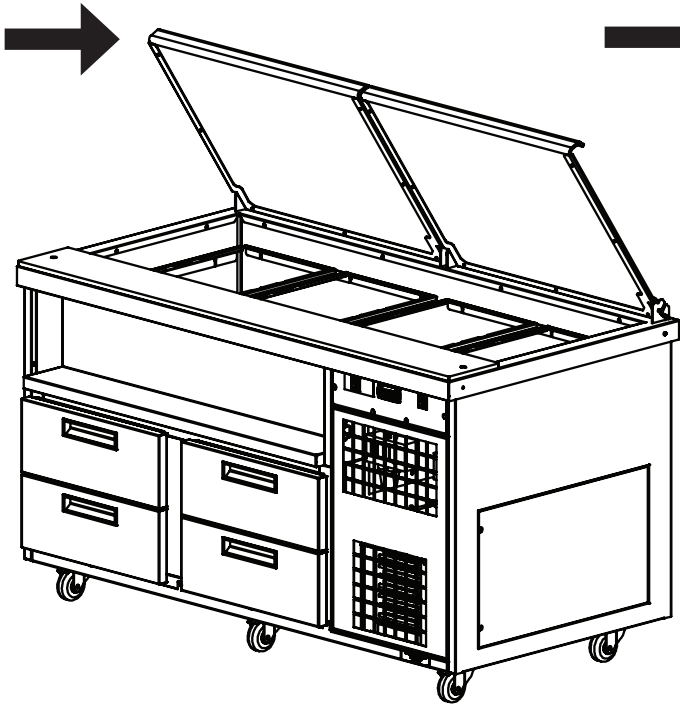

⌚
Ready

CLEANING AND MAINTENANCE

⚠ WARNING

Do not use steel wool as this will cause the unit to rust and void any warranty.

General cleaning

- Clean unit daily, using a soft cloth and warm, soapy water or mild detergent.
- A plastic scouring pad and a mild detergent may be used to remove hardened food.
- Turn off unit at breaker before doing extensive refrigeration compartment cleaning or servicing.

NOTE: Do not ever use steel wool, any highly caustic cleaners, acids or ammonia. These may cause corrosion and/or damage to the stainless steel.

DAILY CLEANING

Counter Tops

- Always turn refrigerated counter top off and allow it to defrost before cleaning.
- Cleaning should be done by wiping the refrigerated counter top and pan using a mild soap and water solution.
- Always clean with the direction of the grain in the stainless steel.

Richlite Cutting Boards

- Wash, Rinse and Sanitize when the cutting boards become visibly soiled or at least twice a day (ex. after lunch period and closing)
- If you notice the cutting board color becoming darker over time this is normal and expected.
- Allow to air dry.
- New, stain resistant, Richlite cutting boards bring an authentic look to the sandwich unit.
- DO NOT use bleach to clean the boards.
- Avoid using the abrasive side of the sponge as this may scratch the surface of the boards.

Refrigerated Drawers

- Remove the pans and clean, rinse, sanitize and let air dry.
- Remove the pan supports and clean, rinse, sanitize and let air dry.
- Remove drawers by pulling drawer out and lifting up.
- Clean drawers and inside surfaces of cabinet with a warm soapy water solution - and dry.
- Wipe down the center Mullion with a warm soapy water solution - and dry.

DAILY CLEANING - continued

Night Covers

- Night covers should be cleaned at least once per day.
- Remove covers and wipe down with a soft cloth and a mild soapy water solution.

CAUTION Do not use an abrasive cloth as this will scratch the surface of the glass.

Drawer Gaskets

- Gaskets require regular cleaning to prevent mold and mildew build-up and also to keep the elasticity of the gasket. Gasket cleaning can be done with the use of warm soapy water.

CAUTION

Avoid full strength cleaning products on gaskets as this can cause them to become brittle and prevent proper sealing.

Never use sharp tools or knives to scrape or clean the gasket which could possibly tear the gasket and rip the bellows.

Gaskets can easily be replaced and do not require the use of tools or authorized service persons. The gaskets are "Dart" style and can be pulled out of the groove in the door and new gaskets can be "pressed" back into place.

MAINTENANCE MONTHLY

Refrigerated unit condenser coils

The condenser coils should be checked monthly for grease and dirt buildup.

If any buildup is present on the coil take the following steps:

- Remove the front grill cover from the compressor compartment. (magnetically secured)
- If the buildup on the coil consists of only light dust and debris the condenser coil can be cleaned with a simple brush, heavier dust build up may require a vacuum or even compressed air to blow through the condenser coil.

CAUTION Always clean in the direction of the fins. Do not bend the fins as this will effect the performance of your unit.)

- If heavy grease is present degreasing agents are available for refrigeration use and specifically for the condenser coils. The condenser coil may require a spray with the degreasing agent and then blown through from the inside out, with compressed air.
- Failure to maintain a clean condenser coil can initially cause high temperatures and excessive run times. Continuous operation with dirty or clogged condenser coils can result in compressor or fan failures. Neglecting the condenser coil cleaning procedures will void any warranties associated with the compressor or cost to replace the compressor and/or fan.
- Maintenance of the evaporator coil and drain pan should be completed by a certified technician.

SPECIFICATIONS

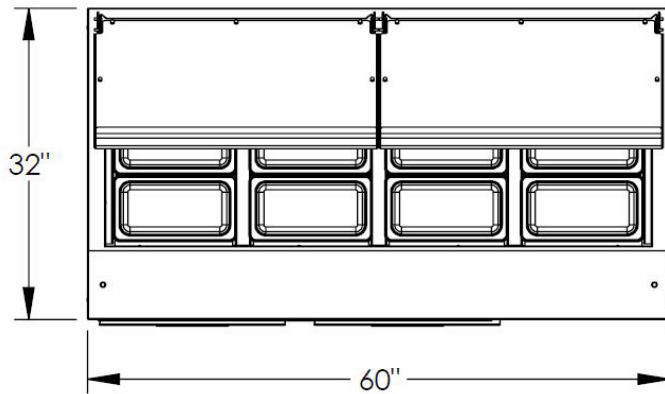

RBD - 60 CP4(D) - 120

Model Type	Cabinet Length	Model Configuration	Pan Depth	Voltage
RBD Refrigerated Base Duplexed	60 Inch	TC4: Tri-Channel 4 Section	10" Deep	120
		CP4: Cold Pan Standard 7 4 Section	8" Deep	
			D 10" Deep	

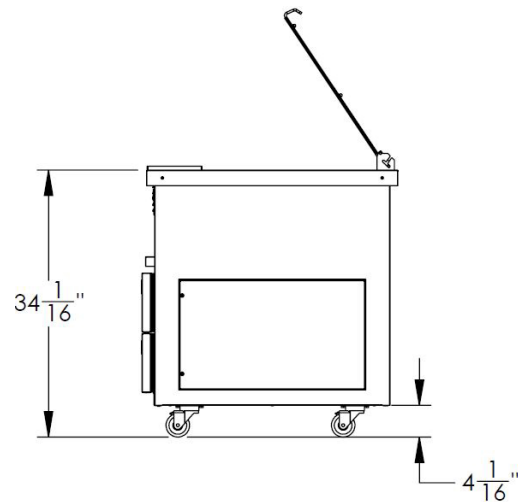
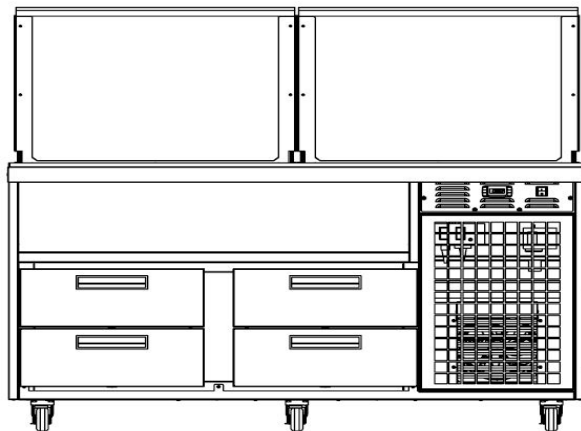

ELECTRICAL SPECIFICATIONS:

Model	120 Volt-60HZ	
	Amps	NEMA
RBD-60	9.5	5-15

DIMENSIONS:

Model	Width		Height		Depth		Cube ft. crated	Crated Ship Weight	
	in.	cm	in.	cm	in.	cm		lbs.	kg
RBD-60-TC4-120	60	152.4	34.063	86.52	32	81.28	62	620	281
RBD-60-CP4-120	60	152.4	34.063	86.52	32	81.28	62	620	281
RBD-60-CP4D-120	60	152.4	34.063	86.52	32	81.28	62	620	281

Freight Class: 100

WIRE DIAGRAM



ELC0307

Wire Diagram –
Duplex Cold Pan

6/28/18 Rev. 2

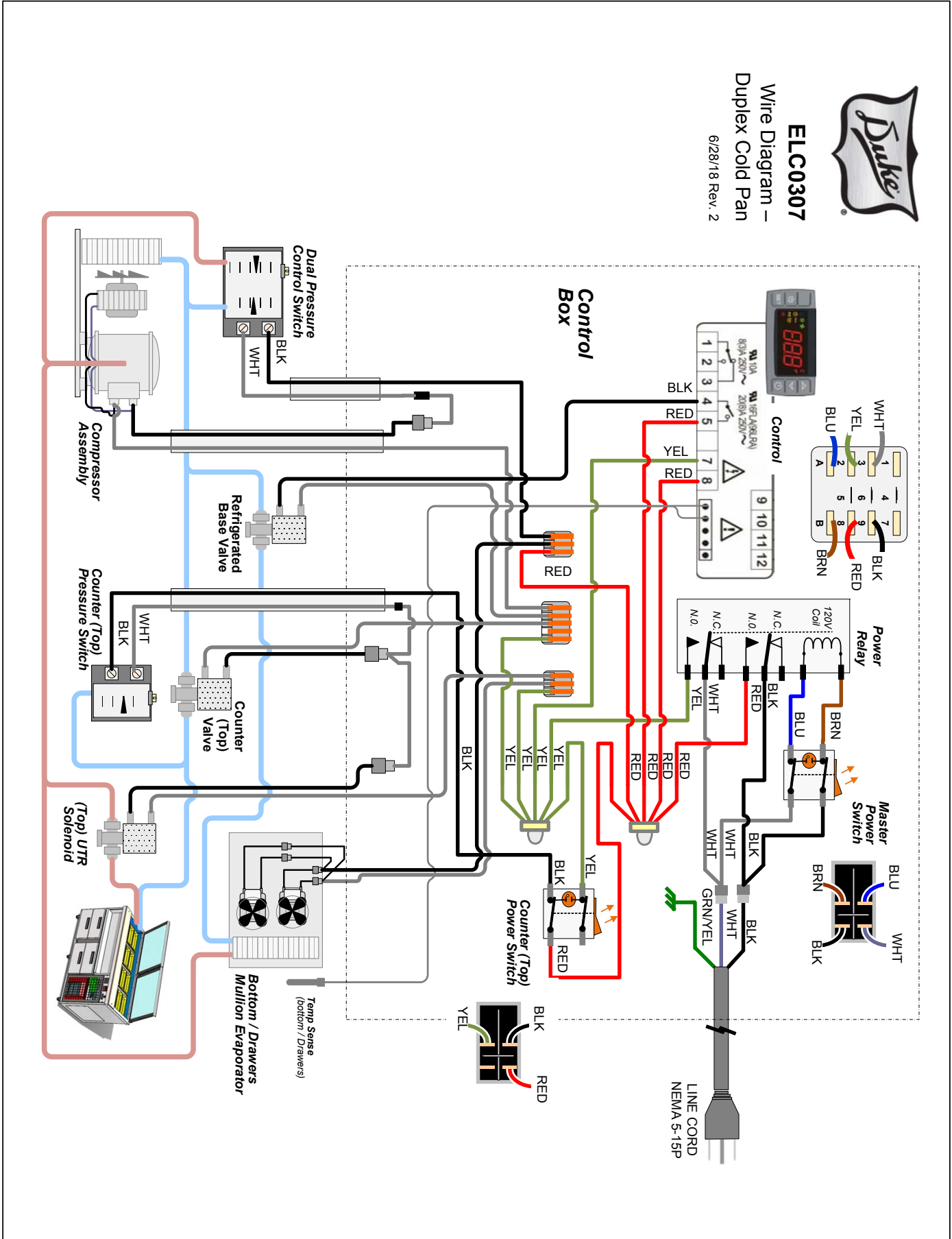

WIRE DIAGRAM

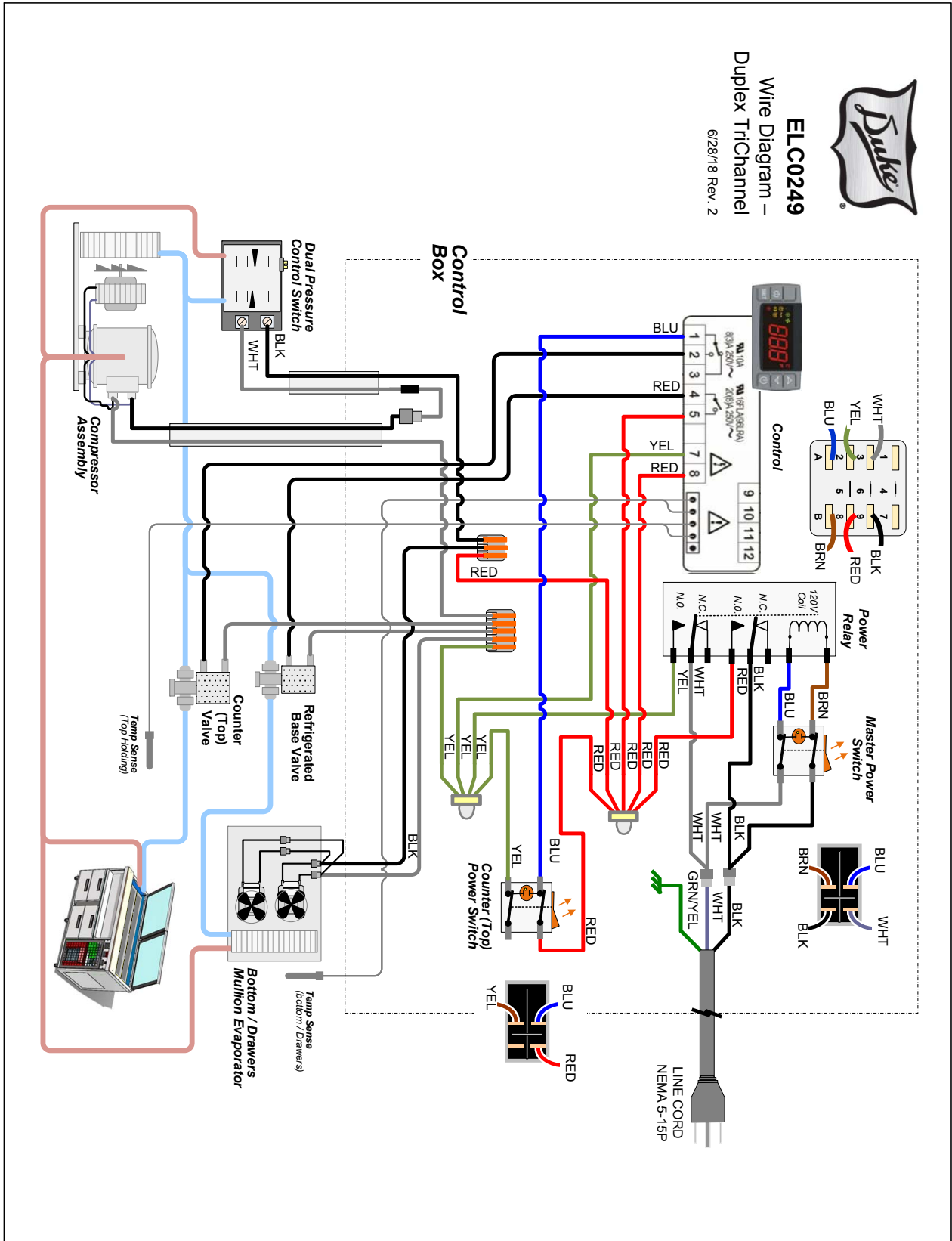

ELC0249

Wire Diagram –
Duplex TriChannel
6/28/18 Rev. 2



Duke Manufacturing Co.
2305 N. Broadway
St. Louis, MO 63102

Phone: 314-231-1130
Toll Free: 1-800-735-3853
Fax: 314-231-5074

www.dukemfg.com