



"Your Solutions Partner"

MODEL PFB PROOFER BASE



Installation, Operation, Parts & Service Manual

319558E

CONTENTS

| | Page |
|--|-------------|
| SPECIFICATIONS | 3 |
| GENERAL PROOFING INFORMATION | 3-4 |
| FROZEN DOUGH - PROBLEMS, CAUSES & REMEDIES | |
| LACK OF VOLUME | 5 |
| TOP MUCH VOLUME | 5 |
| CRUST COLOR TOO PALE | 5 |
| CRUST COLOR TOO DARK | 6 |
| CRUST TOO THICK | 6 |
| POOR CRUMB TEXTURE (CRUMBLY) | 6 |
| STREAKING OR SPOTTING ON CRUST (WHITE) | 6 |
| STREAKING OR SPOTTING ON CRUST (DARK) | 6 |
| DOUGH AGE AND CHARACTERISTICS | |
| YOUNG DOUGH (UNDERPROOFED) | 7 |
| PROPERLY PROOFED | 7 |
| GENERAL COMMENTS | 7 |
| OLD DOUGH (OVERPROOFED) | 7 |
| DIAGNOSTICS | 8 |
| REPLACEMENT PARTS | 9 |
| BAKING CENTER CONTROLS | 10 |
| WIRING DIAGRAM | 11 |

NOTICE:

Please supply the Model Number and the Serial Number when ordering replacement parts or requesting service.

We recommend service by Duke Authorized Service Agencies during and after the warranty period.

Specifications

Power to the proofer base is supplied through a nine foot (9') power cord, 3-wire, 14 gauge, equipped with a NEMA 5-15 CAP grounded plug.

The master on/off switch connects to the axial fan, thermometer transformer, (120v primary/12v secondary) and to the controller, which has a temperature range from 85° - 165°F.

The controller provides power to the air heat element (10-15 watts), and to the proofer ready light. A second (500 watt) element used to regulate humidity in the cabinet is controlled by an infinite switch. (The humidity element will come on only when the air heat element is on.) The humidity element heats a pan of water in the bottom of the oven producing steam vapor.

A sixty minute timer controls the timed proof cycle, and connects power to a buzzer indicating the end of the cycle.

There are two probes within the proofer cavity. One is connected to the controller to sense oven temperature. The second probe is connected to the digital thermometer to indicate oven temperature.

The axial fan located in the bottom of the oven circulates heated air throughout the cavity. The fan runs continuously when the main on/off switch is turned on. Opening or closing the door has no effect on the heat or fan controls.

General Proofing Information

Today many bakers use frozen dough products in their operations. Frozen doughs are ready for traying, thawing, proofing (if required), baking and finishing. The baker bypasses mixing, dividing, make-up and fermentation time.

Handling Frozen Dough

Frozen dough must be kept at a temperature of -10°F with minimal fluctuations to prevent product damage. Be sure to rotate your inventory so that the first product stocked is the first product to be used.

Frozen dough is affected by three factors: Time,

temperature and humidity. Time and temperature are easily controlled with properly maintained equipment. Correct proofer humidity control can only be maintained with a balance between temperature and humidity settings.

Retarder Principles

Retarders provide a location for the frozen dough to thaw slowly, until it reaches a state of even temperature throughout the dough piece. Retarders protect the dough from the unequal thawing caused by excessively warm locations. The best retarders are designed to promote a controlled, cool, slightly moist environment. To eliminate moisture loss and crusting it is often still appropriate to cover the entire pan of trayed product with a heavy plastic bag.

NOTE: Condensation can cause thin, close fitting plastic bags (like trash bags) to stick to the dough. This often creates damaged surfaces when the plastic is pulled free. Baking supply houses carry zippered "elephant bags" specifically for the retarding process.

By keeping the dough between 33° - 40°F the yeast activity in the dough is minimal, yet limited fermentation does occur improving product flavor and dough handling characteristics. Doughs held in the retarder for over 48 hours often will develop strong "sour" aromas and flavors, and if baked, will result in inferior crumb texture and shelf life. Follow and understand the practices outlined on the following pages when retarding your frozen product:

1. Maintain temperature between 33° - 40°F
2. Avoid formation of crust or skin on dough pieces
3. Retard 12-16 hours (overnight)
4. Do not over-retard product (sour product)
5. Longer retards will require shorter proof times.
6. Fermentation begins

Proofer Operation

For the best results in a frozen dough operation, a relative humidity of 70% - 75% is desirable, with a temperature between 90° - 110°F. The humidity and temperature settings will vary depending on the strength and kind of dough to be proofed.

Larger pieces of dough should be proofed at a lower temperature while smaller pieces are proofed at a higher temperature.

Basic yeast dough should be at room temperature when it is placed in the proofer. Placing retarded dough (directly from the walk-in or refrigerator) into the proofer cabinet will often result in excessive build up of condensation on the surface of the dough. This may lead to crust imperfections (spotting and streaking) and blistering. In severe cases this may often result in total collapse of the baked product after removal from the oven.

It is important to stage your retarded product into the proofer to avoid "overproofing". For optimal results the product must be baked immediately after the proofing process.

The majority of yeast-raised products can be proofed successfully between 90° - HOT and 70% - 75% relative humidity. The quality of your final product will depend on the initial product quality and handling from the freezer to the oven.

Proofing Bagels

The proofing process allows the bagels to warm up and to expand slightly before they are boiled. Bagels which are not proofed sufficiently, may not rise to the surface when they are boiled. However, overproofed bagels will tend to collapse after boiling and before they are placed in the oven.

Optimum temperatures and times will vary for various bagel formulations. All bagels should be proofed at a low relative humidity (65% - 75% R.H.).

Bagels which have been held overnight in a retarder or for a short time in a freezer are usually allowed to proof at lower temperatures (86° - 90°F) than bagels processed without interruption. Continuously produced bagels are generally proofed at 104°-110°F.

Frozen Dough Problems, Causes & Remedies Bread & Rolls

PROBLEM: lack of Volume (Too Small)

Possible Causes

1. Incomplete Thawing
2. Loaves Too Small for Pan
3. Underproofed
4. Oven Temperature Too High
5. Dough Too Old
6. Dough Has Been Thawed and Refrozen
7. Dough is Dry

Remedy

Thaw completely or allow to proof longer. (The colder the dough, the longer the necessary proofing time.)

Use proper sized pans or increase size of dough.

Proof at proper temperature, humidity and time.

Use oven thermometer to check oven temperature against temperature dial. Recalibrate dial if necessary

Rotate inventory. Use "First In, First Out" system. Use products with earliest date codes first.

Maintain uniform freezer temperature at minus 10°F.

Do not Refreeze Thawed dough.

Place frozen dough in freezer immediately on receipt.

Retard product in sealed plastic bags.

Increase moisture, (humidity setting) in proof box.

PROBLEM: Too Much Volume (Too Large)

Possible Causes

1. Over Proofing
2. Oven Temperature Too Low
3. Loaves Too Large for Pans
4. Dough Has Risen Too Much During Proofing

Remedy

Proof at proper temperature, humidity and time.

Use oven thermometer to check accuracy of dial indicator.

Use proper sized pan or decrease size of dough.

Remold dough into proper shape as outlined in manufacturers directions and let rise again.

PROBLEM: Crust Color is Pale (Too Light)

Possible Causes

1. Thawing Time Too Long; Dough Has Aged
2. Crust Has Developed on Dough
3. Insufficient Humidity in Proof Box.
4. Oven Temperature Too Low

Remedy

Retard dough in properly controlled retarding cabinet (38°-40°F)

Keep dough pieces in plastic bag while thawing; maintain proper humidity, steam or moisture in proof box.

Maintain proper temperature and humidity levels; check water reservoir.

Use oven thermometer to check accuracy of dial indicator.

PROBLEM: Crust Color is Too Dark

Possible Causes

1. Dough Improperly Thawed
2. Oven Temperature Too High

Remedy

Thaw completely according to instructions.
Use thermometer to check accuracy of dial indicator.

PROBLEM: Crust Blisters:

Possible Causes

1. Careless Molding
2. Overproofing

Remedy

Mold retarded product to manufacturers specifications.
Proof at proper temperature, humidity and time.

PROBLEM: Crust Too Thick

Possible Causes

1. Dough Has Aged Too Much After Thawing
2. Crust Develops During Proofing
3. Oven Temperature Too Low

Remedy

Thaw properly in plastic bags to avoid formation of crusting.
Maintain proper humidity, moisture and temperature levels in proofer cabinet.
Use oven thermometer to insure that dial indicator is accurate.

PROBLEM: Poor Crumb Texture (Crumbly)

Possible Causes

1. Dough Has Aged Too Much
2. Overproofed
3. Proof Box Temperature Too High
4. Oven Temperature Too Low

Remedy

Thaw properly in plastic bags; keep refrigerated to control aging.
Proof at proper temperature, humidity and time.
See Above.
Use oven thermometer to insure correct calibration of oven dial.

PROBLEM: Streaking or Spotting on Crust (White)

Possible Causes

1. Overproofed

Remedy

Make sure correct proofing practices are followed. Do not put "wet" dough into oven for baking. (Water will serve as insulator preventing even coloration of crust. These white spots are referred to as "fish-eyes".)

PROBLEM: Streaking or spotting on Crust (Dark)

Possible Causes

1. Formulation

Remedy

Dark spotting can often be caused by incomplete mixing in the processing stage of the dough.

Dough Age and Characteristics

Young Dough (Underproofed)

Has the tendency to develop blisters and blemishes during handling. The loaf may often be small in volume, have a "shell-top" and a fox-red color.

Always remember the relationship of heat to the formed loaf. Young dough generates its own internal heat during fermentation. A frozen loaf in the retarder and/or proofer sees heat only from the outside of the loaf. (The interior may be 35°-38°F at the beginning of the proofing cycle.) Premature processing of frozen dough will often result in "coring" or a loaf or roll with an under baked center.

NOTE: The shorter the retarding time, the longer the necessary proofing time.

Cell Structure: The cell structure of young dough is nearly circular. The cell wall is thin and has little resistance to elasticity. This inelasticity often causes the loaf to burst.

Shelf Life and Texture: Young dough has a short shelf life and stales quickly. The texture of the baked loaf will be slightly crumbly.

Properly Proofed

Cell Structure: The cell structure of correctly proofed dough has an elliptical/elongated cell structure and thin cell walls. The dough is readily extensible and holds gases easily.

Shelf Life and Texture: Correctly proofed dough will yield the best product having long shelf life, uniform crumb and enhanced flavor.

General Comments:

95% of all baking problems are caused by incorrect proofing or retarding.

95% of the fermentation in frozen dough occurs during proofing.

The longer the fermentation stage in dough development the shorter the shelf life.

The larger the item the lower the proofing temperature.

Properly proofed pan breads will exhibit "break and shred". This should be subtle in character. The break should occur directly above the lip of the pan and the shredding slightly above the break. This is the result of "oven spring". (Oven spring occurs within the first 10-12 minutes of the bake.)

Old Dough (Overproofed)

As dough ages it becomes more acidic. The finished baked loaf has a lighter crust color as a result of the sugar that is depleted through the fermentation process.

Cell Structure: The cell structure of old dough is elliptical in form and has thick cell walls. The dough is difficult to form. The presence of old cell structure is usually most noticeable in the top or "crown" of the loaf.

DIAGNOSTICS

Equipment Problem

Remedy

Proofer will not operate

Make sure cord is plugged in and wall circuit breaker is turned on. Check power to master switch at black wire #1 & white wire #2. If power is present turn switch on and read voltage across wires #3 & #4. If no voltage is present replace switch.

Proofer on, no fan

Read voltage across wires #4 & #12 going to fan motor. If voltage is present replace fan motor.

Proofer on, no heat

Check power across wires #5, & #7 at air heat element. If voltage is present replace element. If no voltage is present, read voltage from wire #7 on element to ground; if no voltage, check the controller. Amber light will illuminate if controller is working.

Humidity feature not working

(Humidity element energized only when controller is calling for heat to air element.) Turn infinite control on. Verify voltage across L1 & L2 of infinite switch. Read voltage across H1 & H2 of infinite switch; if not present replace infinite switch. If voltage is present check voltage at humidity element at wires #6 & #13. If voltage is present replace humidity element.

Thermostat out of calibration

Check proofer temperature with remote test instrument. Loosen screw to controller knob, turn knob to dial setting that agrees with test instrument reading. Tighten screw.

REPLACEMENT PARTS

| <u># on Diagram</u> | <u>Part #</u> | <u>Description</u> |
|---------------------|---------------|-----------------------------|
| | 314350 | Caster, w/brake |
| | 314351 | Caster, w/o brake |
| | 312559 | Fan, axial |
| | 312429 | Heater, humidity, 500 watts |
| | 312428 | Heater, air, 1045 watts |
| 6 | 553925 | Buzzer |
| 7 | 312074 | Infinite switch |
| 8 | 312568 | Thermostat |
| 9 | 312566 | Transformer |
| 10 | 312574 | Thermometer, w/probe |
| 11 | 312573 | Probe |
| 12 | 512289 | Power switch |
| 13 | 153203 | Heat light |
| 14 | 156255 | Timer |
| 15 | 153142 | Knob |
| | 153211 | Power Cord |
| | 00924 | Door assembly |
| | 316535 | Wire rack |
| 19 | 314861 | Control overlay |

Baking Center Controls

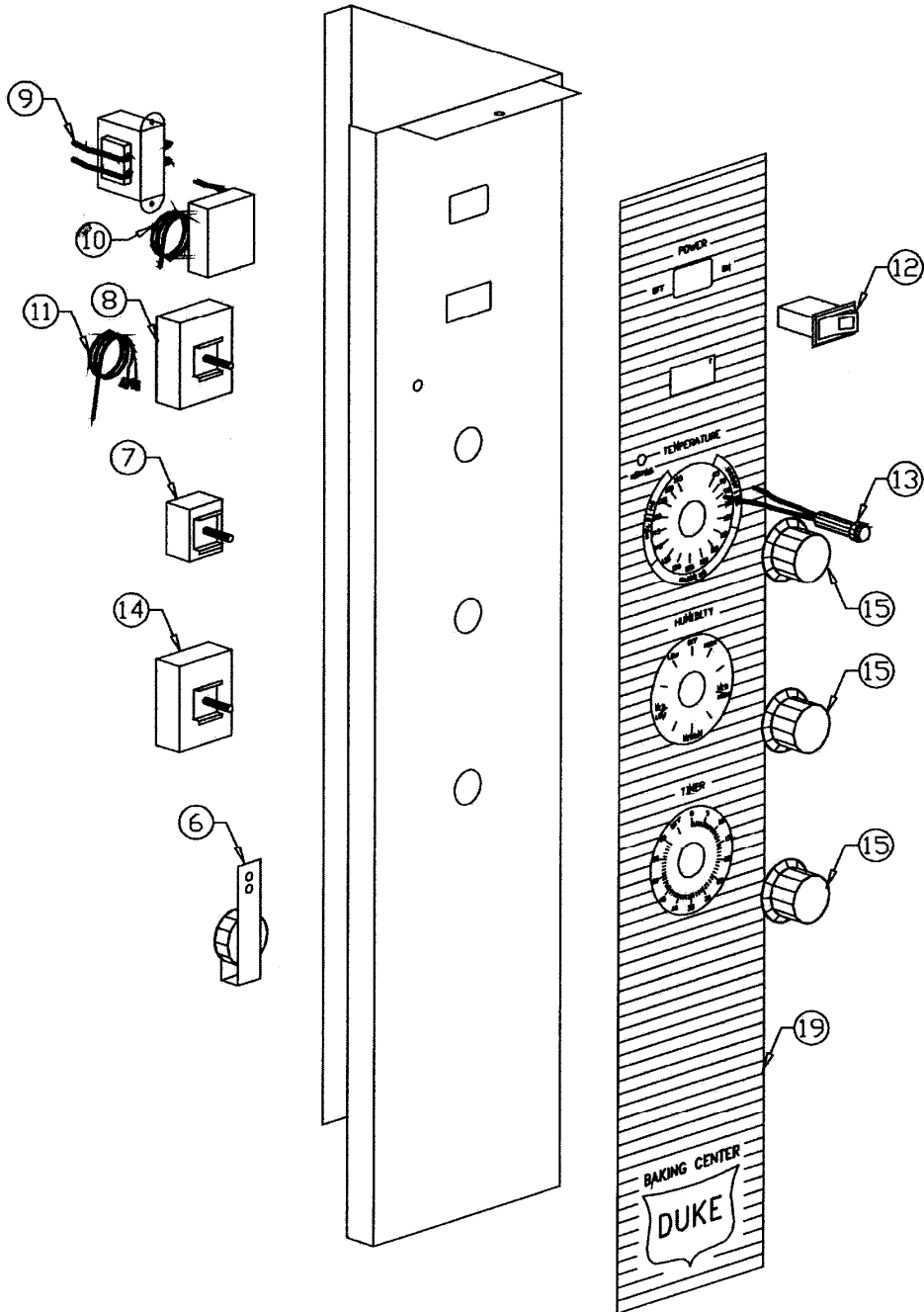

**SCHEMATIC DIAGRAM FOR MODELS PFB-1 & PFB-2 PROOFER
120 VAC 1 PH. 60 HZ.**

