



Your Solutions Partner

# Installation and Operation Manual

## HSHU (HEAT SINK HOLDING UNIT)

### MODEL

HSHU 13 SERIES  
HSHU 22 SERIES  
HSHU 23 SERIES  
HSHU2 22 SERIES

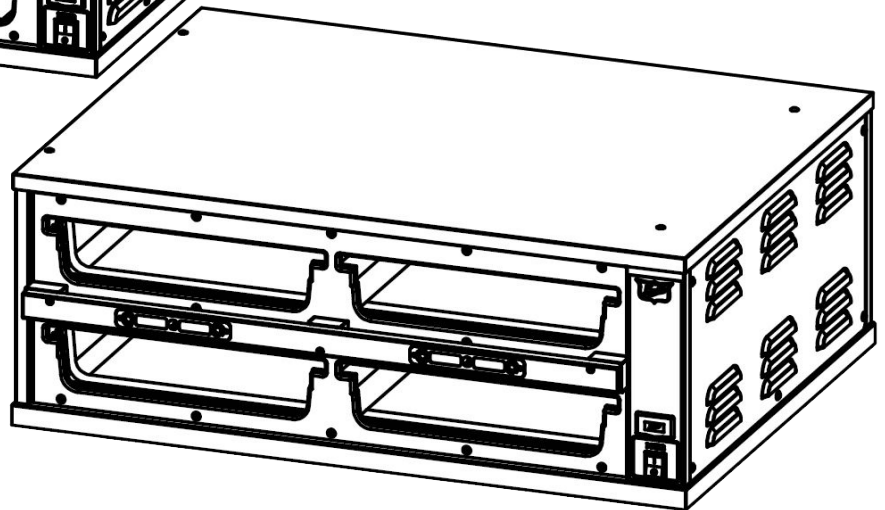
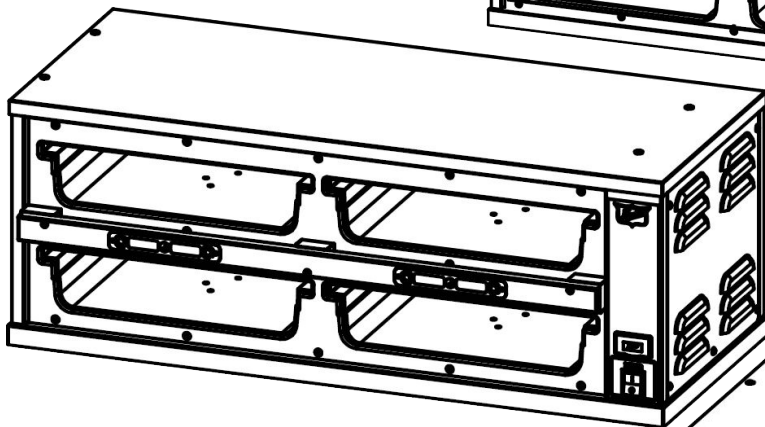
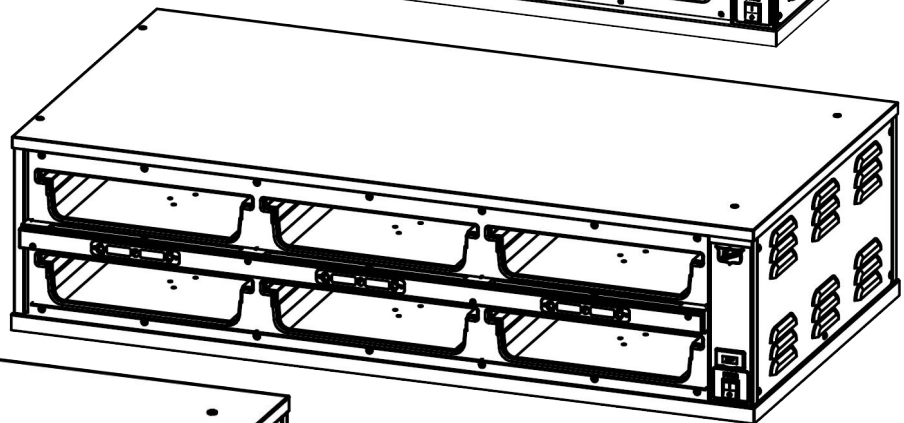
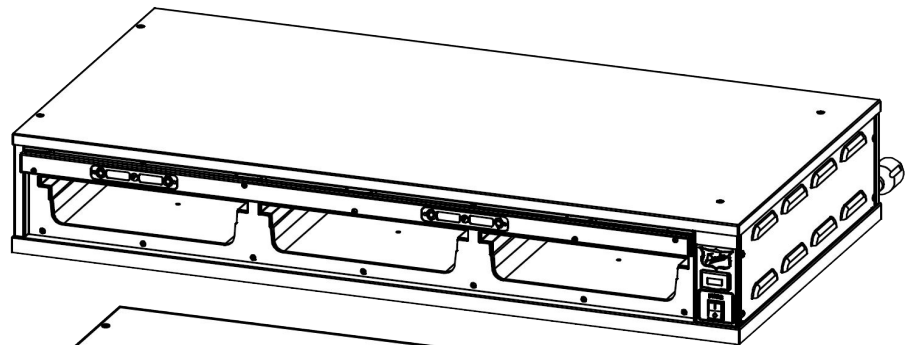

**CAUTION:** Please read this manual completely before attempting to install, operate or service this equipment

*This manual is Copyright © 2021 Duke Manufacturing Co. All rights reserved.  
Reproduction without written permission is prohibited. Duke is a registered  
trademark of the Duke Manufacturing Co.*

**P/N 158270  
REV N 04/01/2021**

## TABLE OF CONTENTS

Introduction ..... 2

Important Safety Instructions..... 3

Unit Specifications ..... 5

Electrical Connection..... 9

Installation ..... 10

Operation ..... 11

Cleaning Instruction..... 16

Troubleshooting ..... 17

Parts Lists and Exploded Views` ..... 20

Wire Schematics..... 25

## INTRODUCTION

The Duke HSHU was developed for extended food-holding capabilities to provide consistently high, “just cooked” food quality.

The HSHU utilizes Duke’s patented “heat sink” holding technology that provides even heat distribution to food pans through the bottom and sides. This allows pre-cooked foods to be held for extended periods without noticeable degradation of quality, reducing food scrap/waste.

The self contained, individually formed, sealed compartments of the HSHU eliminates food odor and taste transfer. Because the compartments are sealed and formed to the shape of the pan, no disassembly is required for cleaning or product changes.

The unique design of the HSHU allows multiple temperature operation for all existing product groups.

### SERIAL NUMBER LOCATION

The Serial Number Data Label is located on the rear of the unit, above the power cord connection. Refer to the Serial Number Data Label for proper electrical requirements. The serial number and model number are required when communicating with the Duke Service Dept.

## ELECTRICAL WARNINGS

**THIS MANUAL HAS BEEN PREPARED FOR PERSONNEL QUALIFIED TO INSTALL ELECTRICAL EQUIPMENT, WHO SHOULD PERFORM THE INITIAL FIELD STARTUP AND ADJUSTMENTS OF THE EQUIPMENT COVERED BY THIS MANUAL.**

**READ THIS MANUAL THOROUGHLY BEFORE OPERATING, INSTALLING OR PERFORMING MAINTENANCE ON THE EQUIPMENT.**

**⚠ WARNING:** Failure to follow all the instructions in this manual can cause property damage, injury or death.

**⚠ WARNING:** Improper installation, adjustment, alteration, service or maintenance can cause property damage, injury or death.

**⚠ WARNING:** (US/CAN ONLY) Electrical connections should be performed only by a certified professional.

**⚠ WARNING:** Electrical and grounding connections must comply with the applicable portions of the National Electric Code and/or all local electric codes. Failure to comply with this procedure can cause property damage, injury or death.

**⚠ WARNING:** Before connecting the unit to the electrical supply, verify that the electrical and grounding connections comply with the applicable portions of the National Electric Code and/or other local electrical codes. Failure to comply with this procedure can cause property damage, injury or death.

**⚠ WARNING:** Before connecting the unit to the electrical supply, verify that the electrical connection agrees with the specifications on the data plate. Failure to comply with this procedure can cause property damage, injury or death.

**⚠ WARNING:** UL73 grounding instructions: This appliance must be connected to a grounded, metal, permanent wiring system. Or an equipment-grounding conductor must be run with the circuit conductors and connected to the equipment-grounding terminal or lead on the appliance. Failure to comply with this procedure can cause property damage, injury or death.

**⚠ WARNING:** Appliances equipped with a flexible electric supply cord, are provided with a three-prong grounding plug (or a CEE7 Plug for International CE Units). It is imperative that this plug be connected into a properly grounded receptacle. Failure to comply with this procedure can cause property damage, injury or death.

**⚠ WARNING:** If the receptacle is not the proper grounding type, contact an electrician. Do not remove the grounding prong from the plug. Failure to comply with this procedure can cause property damage, injury or death.

**⚠ WARNING:** Before performing any service that involves electrical connection or disconnection and/or exposure to electrical components, always perform the Electrical LOCKOUT/TAGOUT Procedure. Disconnect all circuits. Failure to comply with this procedure can cause property damage, injury or death.

## ELECTRICAL WARNINGS - CONTINUED

**⚠ WARNING:** Before removing any access panels or servicing this equipment, always perform the Electrical LOCKOUT/TAGOUT Procedure. Be sure all circuits are disconnected. Failure to comply with this procedure can cause property damage, injury or death.

**⚠ WARNING:** Do not operate this equipment without properly placing and securing all covers and access panels. Failure to comply with this procedure can cause property damage, injury or death.

**⚠ WARNING:** For your safety, do not use or store gasoline or other flammable vapors or liquids in the vicinity of this or any other appliance. Failure to comply can cause property damage, injury or death.

**⚠ WARNING:** In the event of a power failure, do not attempt to operate this appliance. Failure to comply can cause property damage, injury or death.

**⚠ WARNING:** This appliance is not intended for use by persons (including children) with reduced physical, sensory or mental capabilities, or lack of experience and knowledge, unless they have been given supervision or instruction concerning use of the appliance by a person responsible for their safety. Children should be supervised to ensure they do not play with the appliance.

### CAUTION

Observe the following:

- Minimum clearances must be maintained from all walls and combustible materials.
- Keep the equipment area free and clear of combustible material.
- Maintain adequate clearance for air openings.
- Operate equipment only on the type of electricity indicated on the data sticker.
- Retain this manual for future reference.

# SPECIFICATIONS

## HSHU-22

<b>Shipping Weight:</b>	180 lbs/82 kg	
<b>Electrical:</b>	HSHU-22-208	208 V ~, 12.0 A (12,0A), 2400 W, 60 Hz
	HSHU-22-230CE	230 V ~, 10.5 A (10,5A), 2400 W, 50 Hz
	HSHU-22-240	240 V ~, 10.0 A (10,0A), 2400 W, 60 Hz

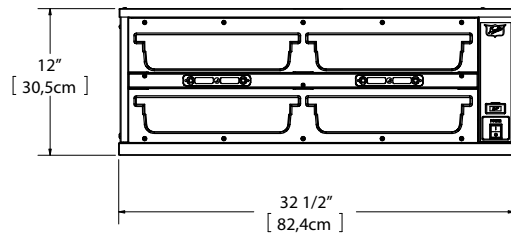
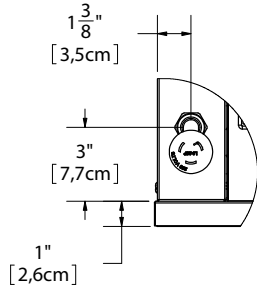



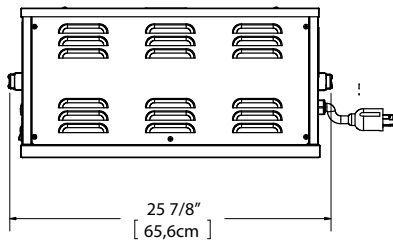

FRONT

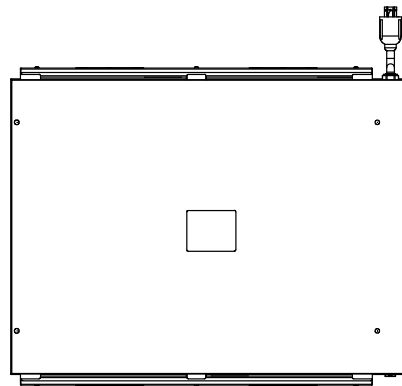

END



TOP

Compliance Declaration		
 LISTED COMMERCIAL COOKING APPLIANCE	Standard: UL197	File: KNGT.E17421
 INDEXER COMMERCIAL APPAREIL DE CUISINE	Standard: CSA-C22.2 No. 109	File: KNGT7.E17421
	Standard: ANSI / NSF 4	File: TSQT.E157479
	Directive 2006/95/EC: EN60335 -1:2002, A1, A2, A11, A12 EN 60335-2-49:2003	Directive 89/336/EEC and 2004/108/EC: EN61000-3-2                      EN 55014-1 EN61000-3-3                      EN55014-2
	WEEE RoHS Directive 2002/96/EC	

### HSHU-23

<b>Shipping Weight:</b>	275 lbs/125 kg	
<b>Electrical:</b>	HSHU-23-208	208 V ~, 18.0 A (18,0A), 3600 W, 60 Hz
	HSHU-23-230CE	230 V ~, 15.7 A (15,7A), 3600 W, 50 Hz
	HSHU-23-240	240 V ~, 15.0 A (15,0A), 3600 W, 60 Hz

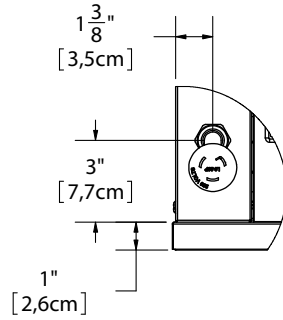

IEC 60309  
3 Pin & Sleeve Plug  
230V  
(UK CE UNITS)



L6-30P  
Twist Lock Plug  
208 & 240V  
(US/CAN)

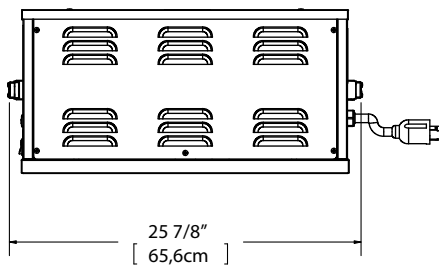
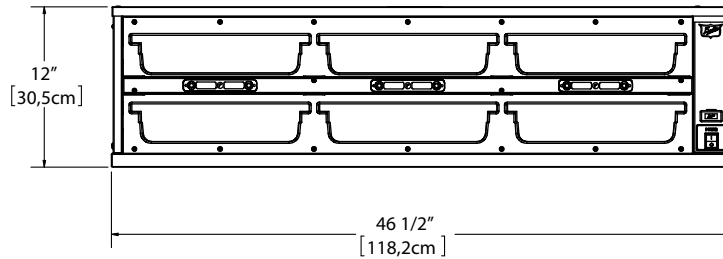



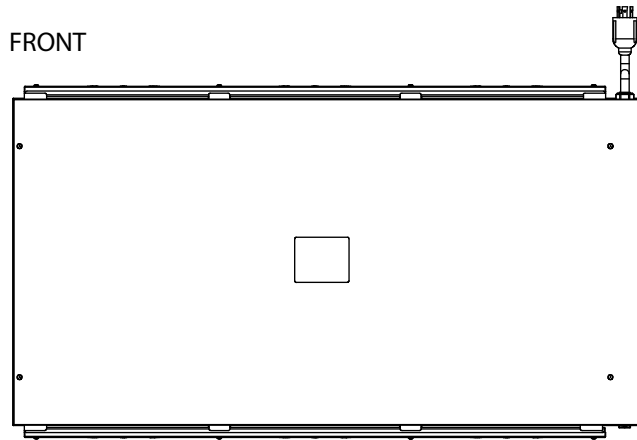

FRONT



END

TOP

Compliance Declaration		
	Standard: UL197	File: KNGT.E17421
	Standard: CSA-C22.2 No. 109	File: KNGT7.E17421
	Standard: ANSI / NSF 4	File: TSQT.E157479
	Directive 2006/95/EC: EN60335 -1:2002, A1, A2, A11, A12 EN 60335-2-49:2003	Directive 89/336/EEC and 2004/108/EC: EN61000-3-2 EN 55014-1 EN61000-3-3 EN55014-2
	WEEE RoHS Directive 2002/96/EC	

## HSHU2-22

<b>Shipping Weight:</b>	175 lbs/80 kg	
<b>Electrical:</b>	HSHU2-22-208	208 V ~, 12.0 A (12,0A), 2400 W, 60 Hz

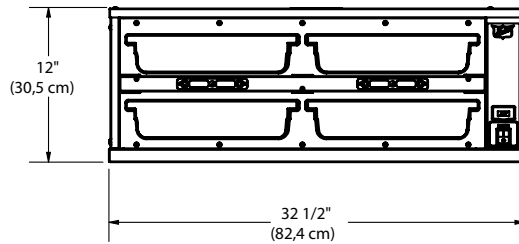
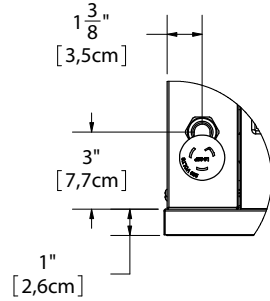

FRONT





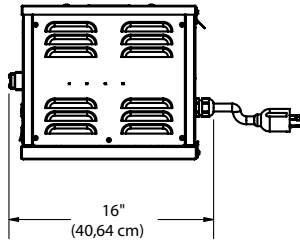

L6-20P  
Twist Lock Plug  
208 & 240V  
(US/CAN)

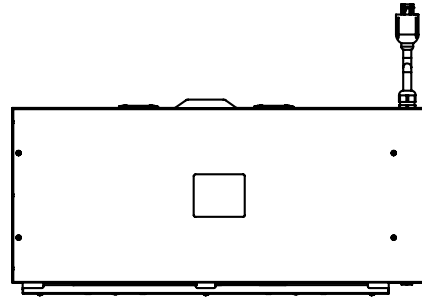

END







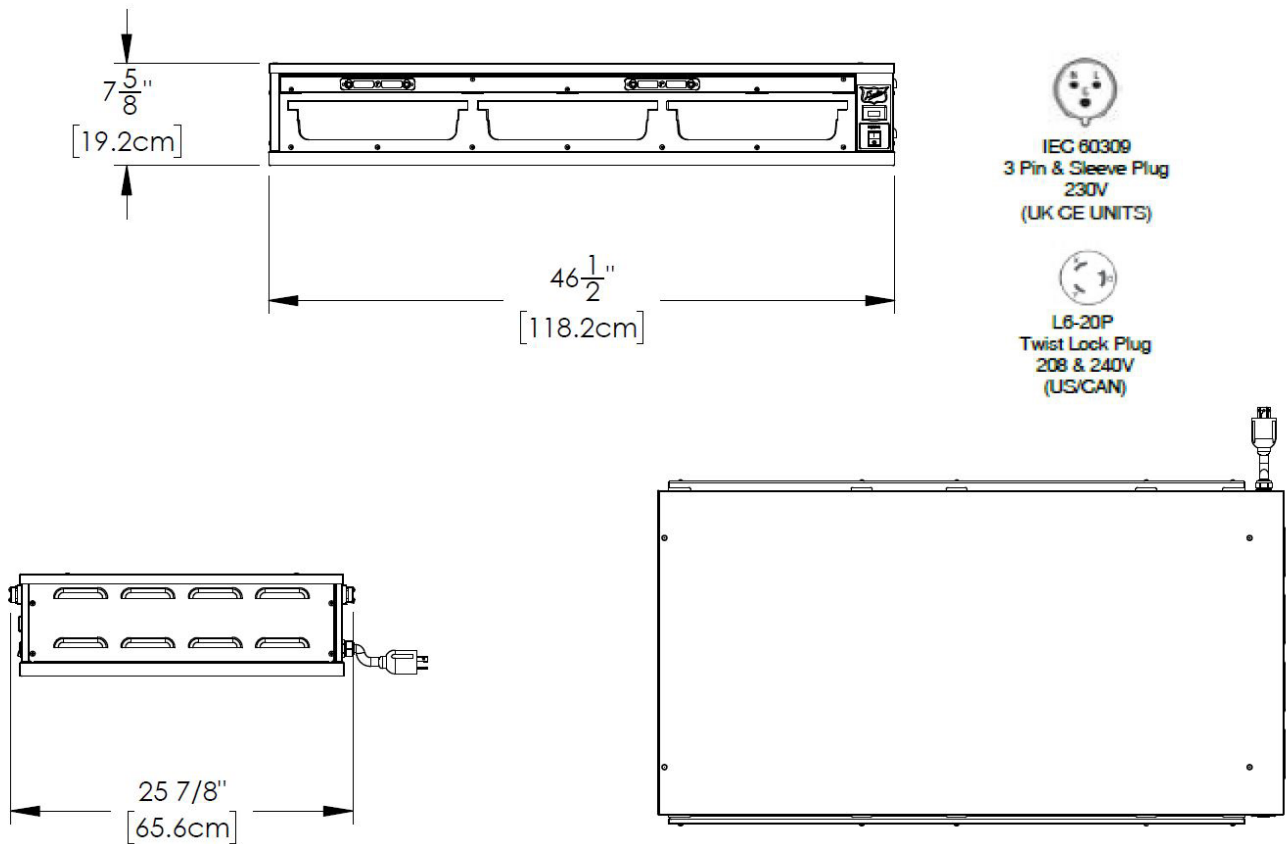

TOP

Compliance Declaration		
	Standard: UL197	File: KNGT.E17421
	Standard: CSA-C22.2 No. 109	File: KNGT7.E17421
	Standard: ANSI / NSF 4	File: TSQT.E157479
	Directive 2006/95/EC: EN60335 -1:2002, A1, A2, A11, A12 EN 60335-2-49:2003	Directive 89/336/EEC and 2004/108/EC: EN61000-3-2      EN 55014-1 EN61000-3-3      EN55014-2
	WEEE RoHS Directive 2002/96/EC	

## HSHU-13

<b>Shipping Weight:</b>	140 lbs/64 kg	
<b>Electrical:</b>	HSHU-13-208	208 V ~, 9.0 A (9.0A), 1800 W, 60 Hz
	HSHU-13-230	230 V ~, 7.9 A (7.9A), 1800 W, 50 Hz



Compliance Declaration		
	Standard: UL197	File: KNGT.E17421
	Standard: CSA-C22.2 No. 109	File: KNGT7.E17421
	Standard: ANSI / NSF 4	File: TSQT.E157479
	Directive 2006/95/EC: EN60335-1:2002, A1, A2, A11, A12 EN 60335-2-49:2003	Directive 89/336/EEC and 2004/108/EC: EN61000-3-2 EN 55014-1 EN61000-3-3 EN55014-2
	WEEE RoHS Directive 2002/96/EC	

## ELECTRICAL CONNECTION

**The US HSHU models are dual voltage, factory wired for 208 or 240 Volts AC, single phase, 60 Hz. International models are single voltage, 230V ~, Single phase, 50 Hz.**

**⚠ WARNING:** Before connecting the unit to the power source, verify that the voltage and phase of the power source are identical to the voltage and phase information on the data label.

**⚠ WARNING:** Electrical and grounding connections must comply with the applicable portions of the national electrical code and/or other local electrical codes.

**⚠ WARNING:** Do not store or use gasoline or other flammable vapors or liquids in the vicinity of this or any other appliance.

Refer to wiring diagram in this manual for proper connection. Do not store flammables near unit.

1. At the circuit breaker, turn off power to the circuit to which the unit is to be connected.
2. Check that the unit Power ON/OFF Switch is in the OFF position.
3. Connect the power cord on the back of the unit to the electrical power source.

Refer to wiring diagram in this manual for proper connection. Do not store flammables near unit.

1. At the circuit breaker, turn off power to the circuit to which the unit is to be connected.
2. Check that the unit Power ON/OFF Switch is in the OFF position.
3. Connect the power cord on the back of the unit to the electrical power source.
4. At the circuit breaker, turn on power to the circuit.

**NOTICE:** If the supply cord is damaged, it must be replaced by a special cord or a special cord assembly available from Duke Manufacturing Co. or its service agent.

### Earthing Instructions

THE UNIT MUST BE GROUNDED. Grounding reduces risk of electric shock by providing an escape wire for the electric current if an electrical short occurs. This unit is equipped with a cord having a grounding wire with a grounding plug. The plug must be plugged into a receptacle that is properly installed and grounded.

Consult a qualified electrician or service agent if grounding instructions are not completely understood, or if doubt exists as to whether the oven is properly grounded.

DO NOT USE AN EXTENSION CORD. If the product power cord is too short, have a qualified electrician install a three-slot receptacle (or the country specific receptacle for International Units). This unit should be plugged into a separate circuit with the electrical rating as provided on the product data plate.

### EXTERNAL EQUIPOTENTIAL BONDING TERMINAL (EXPORT ONLY)

This equipment has supplemental bonding terminal. The terminal provides an external bonding connection used in addition to the earthing prong on the plug. The terminal provides a connection for bonding to the equipment enclosure. The external equipotential bonding terminal is located on the rear outside surface of the oven, the terminal is marked with this symbol.



# INSTALLATION

Before installing, verify that the electrical service agrees with the specifications on the data label located on the rear of the unit, above the power cord connection. If the electrical service does not agree with the data label, do not proceed with installation. Contact your dealer or local Authorized Duke Servicer immediately.

## UNPACKING

1. Inspect the shipping carton and/or container, carefully noting any exterior damage on the delivery receipt.
2. Contact the carrier immediately and file a damage claim with them. Save all packing materials when filing a claim. Freight damage claims are the responsibility of the purchaser and are not covered by the warranty.
3. Unpack and Inspect the unit for damage.
4. Report any dents or breakage to the source of purchase immediately.

**NOTICE:** Do not attempt to use the unit if damaged.

5. Remove all materials from the unit interior.
6. If the unit has been stored in extremely cold area, wait a few hours before connecting the power.

## INSTALLATION CODES AND STANDARDS

In the United States, the HSHU must be installed in accordance with the following:

1. State and local codes.
2. National Electrical Code (ANSI/NFPA No. 70, latest edition) available from the National Fire Protection Association, Batterymarch Park, Quincy, MA 02269.
3. Vapor Removal from Cooking Equipment, (NFPA-96, latest edition) available from NFPA.

In Canada, the HSHU must be installed in accordance with the following:

1. Local codes.
2. Canadian Electrical Code (CSA C22.2 No. 3, latest edition) available from the Canadian Standards Association, 5060 Spectrum Way, Mississauga, Ontario, Canada L4W 5N6.

For CE Units, the HSHU must be installed in accordance with the following:

1. Local codes.
2. European (IEC/CENELEC) Electrical Code

## LOCATION

**⚠ WARNING:** To avoid risk of electrical shock or death, this unit must be grounded and plug must not be altered.

- The HSHU is designed for access from either side.
- Install the unit on a level counter top surface.
- The power outlet should be located so that plug is accessible when the unit is in place.
- Proper airflow around the unit cools its electrical components. With restricted airflow, the unit may not operate properly and life of the electrical parts is reduced.

**NOTICE:** Do not install the unit next to or above heat sources, such as oven or deep fat fryer.

## CLEARANCE REQUIREMENTS

CLEARANCE REQUIREMENT	CLEARANCE IN INCHES
Top	0
Right Side	0
Left Side	0
Bottom	0
Rear	OPEN

# OPERATION

## CONTROLS

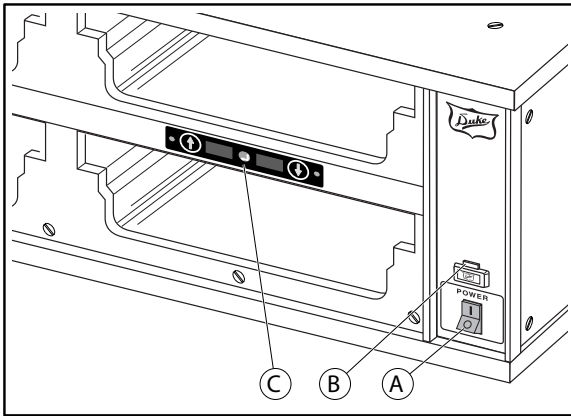

A. Power ON/OFF Switch: There is one Power ON/OFF switch located on the front of the unit.

B. USB Port: The USB port is used by authorized personnel to upload or download menu programming.

C. Menu Bar: The menu bar is located between the upper and lower pans on the front of the unit. An optional menu bar is available on the rear of the unit. The menu bars display the pre-programmed product names. If no product is programmed, the display shows NONE.

## BASIC OPERATION

Use the following procedures to operate the HSHU unit.

- Place the Power Switch, located on the front of the HSHU, in the ON position.



- Allow the unit to heat for at least 20 minutes or until the temperature disappears and the Menu Bars display the pre-programmed product or "NONE" (no product programmed).

**NOTICE:** If the menu bars display HI, LO or SENS at any time during operation of the unit, discontinue use of the affected shelf until the cabinet is serviced.

- Refer to the KEYPAD PROGRAMMING section of the manual for instructions on using and programming the keypad.

Use these procedures to shut the unit down.

- Place the Power Switch in its OFF position.
- Remove all pans.
- Allow the cabinet to cool for approximately 30 minutes.
- Refer to the CLEANING INSTRUCTIONS section of this manual for proper care and cleaning of the cabinet.

## KEYPAD PROGRAMMING

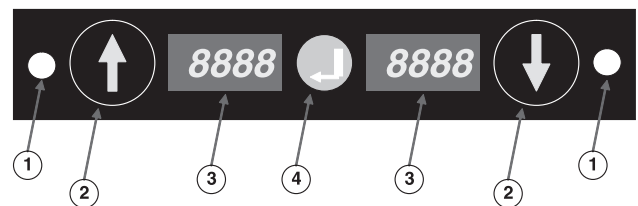

- Status LEDs: Used for indicating status of pan.
  - Non-Illuminated
    - Timer is Inactive - no product in pan OR
    - Timer is Active - product in pan (use pan with GREEN STATUS LED first)
  - Green = Timer is Active - product in pan (use first)
  - Flashing Green = Cook Warning Time reached (cook more product) or keyboard in EDIT MODE (programming).
- Arrow Buttons
  - Used for Starting/Stopping/Resetting Timer.
  - Used for Programming.
  - Indicate which pan the adjacent Status LED and Pan Display are linked to (i.e. Status LED and Pan Display on left side of keyboard are linked to the pan above the keyboard and the Status LED and Pan Display on right side of keyboard are linked to the pan below).
- Pan Display
  - Displays Product Name and Hold Time Remaining (alternates between the two when Timer is active).
- Enter Button
  - Used for Time Decrement and Programming.

## OPERATION - continued

### Power Up

1. Place the Power Switch in the ON position. Software initializes at startup.



2. Until warmer reaches preprogrammed operating temperature, all displays will show the actual temperature.



3. When the set point is reached, Product Name appears on all Pan Displays.



**Note:** For these instructions only the pertinent keypads will be shown, for simplicity, and not the warmer or pans. It is implied that a product pan is located above and below each keypad. Except for units with odd number of shelves where the keypad will be located either above or below the shelf.

### Timer Operation

1. Press Arrow Button that corresponds to pan the product is in. (In this example, there is product in pan above keypad).

Press



2. Status LED turns GREEN (unless same product present in another pan, then Status LED will remain non-illuminated) and Pan Display alternately shows Time Remaining and Product Name.



3. At t=cook time the Status LED begins FLASHING, alarm sounds and Display alternately flashes Time Remaining and Product Name.



4. Push Arrow Button to silence alarm – Status LED remains GREEN and stops flashing.



5. At t=0, alarm sounds, Status LED is FLASHING and "00:00" is FLASHING in the Display. Discard product in pan. Press corresponding Arrow Button to silence alarm and reset timer.



6. Status LED becomes non-illuminated and Display shows Product Name only. The pan is ready for more product.



**Note:** To reset the time when product is depleted, press and release the corresponding arrow key. The status LED will become non-illuminated any status LED on the same product will turn green, indicating use first.

## OPERATION - continued

### Time Decrement

This program is used to alter Hold Time when introducing a product from another warming unit. Example: Transfer CORN from another warmer with 19 minutes left on Hold Time.

1. Press and hold the Arrow Button corresponding to the pan that's being edited for three seconds. The display will appear as shown below with a FLASHING Status LED and a down arrow in the Display indicating the timer is in decrement mode.



"V" denotes timer is in decrement mode

2. Repeatedly pressing the Arrow Button decrements time by one minute per depression.
3. Holding down the button continuously will count the time down.
4. To increment time, press the Enter Button. The arrow on display will point up to denote incrementing time as shown below.
5. Repeatedly pressing the Arrow Button increments time by one minute per depression.
6. Holding down the button continuously will speed the time up.



"V" denotes timer is in increment mode

7. When the proper time is reached on the Display release the Arrow Button and after 5 seconds unit will accept new time and return to normal operation.

**Note: Time cannot increment beyond programmed hold time.**

### Menu Mode

This option is used to change Meal Set and view, Linking, Hold Time and Hold Temp.

### Enter Menu Mode

1. Press and hold the Enter Button for three seconds. Status LED FLASHES GREEN and "MENU" is displayed on left Display and "UP" is displayed on right, indicating upper well information will be displayed.
2. To view lower well information press the Down Arrow Button – "DOWN" will appear in the right Display. FLASHING Status LED will be present on side of keypad corresponding to well being viewed.
3. Press the Enter Button to accept.



### Change Meal Set

**Note:** The Meal Set can be changed globally from any keyboard.

1. Status LED stops flashing and "MEAL" "SET1" appears on the Display.



2. Press the Enter Button again. Status LED FLASHES indicating edit mode.



3. Use the Arrow Buttons to scroll to desired Meal Set and press the Enter Button to accept. Status LED stops flashing and desired Meal Set is displayed.

## OPERATION - continued

Display Link, Hold Time & Temperature

Press Arrow Button repeatedly to scroll through Link, Time and Temperature settings.

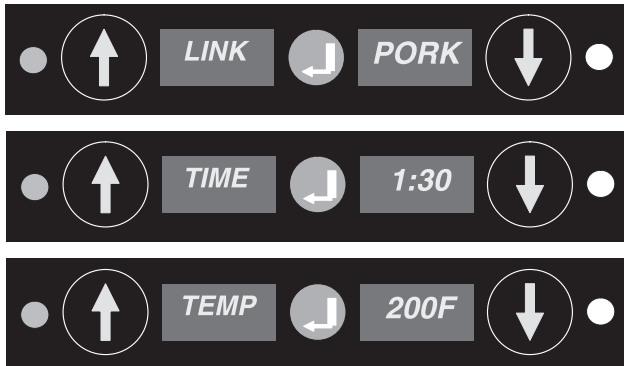

Exit Menu Mode

Scroll to EXIT and press the Enter Button to exit menu mode.



**Note:** To comply with sanitation requirements, do not set the Temperature control lower than 180°F or equivalent.

## CLEANING INSTRUCTIONS

### CLEANING CHECKLIST

**⚠ WARNING:** Do not wash with water jet or hose.

**⚠ WARNING:** Bottom and sides of warmer wells are very hot and cool slowly.

**NOTICE:** Do not use caustic cleaners, acids, ammonia products or abrasive cleaners or abrasive cloths. These can damage the stainless steel and plastic surfaces.

**NOTICE:** Do not use excessive amounts of water when cleaning the HSHU.

Follow these procedures to clean the HSHU:

1. Place the Power Switch in its OFF position.
2. Unplug the cabinet before cleaning.
3. Remove all pans.
4. Allow cabinet to cool for approximately 30 minutes.
5. Wipe down interior and exterior of the cabinet with warm water and mild detergent using a soft cloth.
6. Clean pans using mild detergent and warm water.
7. Ensure all soap is rinsed from plastic pans.

### STAINLESS STEEL CARE

#### Cleaning

Stainless steel contains 70-80% iron, which will rust if not properly maintained. It also contains 12-30% chromium, which forms an invisible passive, protective film that shields against corrosion. If the film remains intact, the stainless steel will remain intact. However, if the film is damaged, the stainless steel can break down and rust. To prevent stainless steel breakdown, follow these steps:

**NOTICE:** Never use any metal tools. Scrapers, files, wire brushes or scouring pads (except for stainless steel scouring pads) will mar the surface.

**NOTICE:** Never use steel wool, which will leave behind particles that rust.

**NOTICE:** Never use acid-based or chloride-containing cleaning solutions, which will break down the protective film.

**NOTICE:** Never rub in a circular motion.

**NOTICE:** Never leave any food products or salt on the surface. Many foods are acidic. Salt contains chloride.

## CLEANING INSTRUCTIONS - continued

For routine cleaning, use warm water, mild soap or detergent and a sponge or soft cloth.

For heavy-duty cleaning, use warm water, a degreaser and a plastic, stainless steel or Scotch-Brite pad.

Always rinse thoroughly. Always rub gently in the direction of the steel grain.

### Preserving and Restoring

Special stainless steel polishing cleaners can preserve and restore the protective film.

Preserve the life of stainless steel with a regular application of a high quality stainless steel polishing cleaner as a final step to daily cleaning.

If signs of breakdown appear, restore the stainless steel surface. First, thoroughly clean, rinse and dry the surface. Then, on a daily basis, apply a high-quality stainless steel polish according to manufacturer's instructions.

### Heat Tint

Darkened areas, called heat tint, may appear on stainless steel exposed to excessive heat, which causes the protective film to thicken. It is unsightly but is not a sign of permanent damage.

To remove heat tint, follow the routine cleaning procedure. Stubborn heat tint will require heavy-duty cleaning.

To reduce heat tint, limit the exposure of equipment to excessive heat.

## TROUBLESHOOTING

**NOTICE:** There are no user serviceable parts on the HSHU. If a malfunction occurs, ensure unit is plugged in then check all switches and circuit breakers. If the malfunction still exists, contact A Duke Manufacturing Company authorized service agent or call 1-800-735-3853.

### ELECTRONIC CONTROL FAULT INDICATIONS

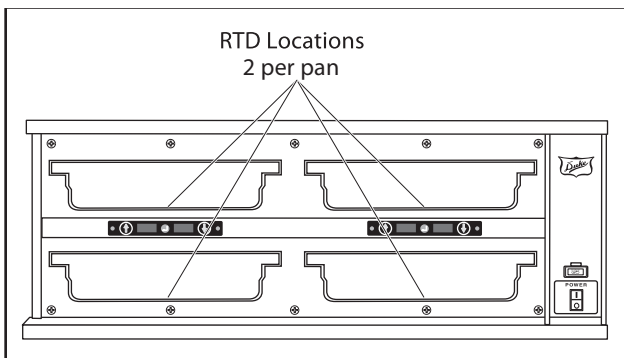

The keypad display provides an indication to alert the operator to failures in the heater circuit. The possible fault conditions are as follows:

1. **Over-Temperature Fault** – An over-temperature fault occurs when the control senses that the shelf temperature is higher than the specified factory preset temperature for thirty minutes. This occurs when the power is not removed from the heating element after the shelf has achieved the preset temperature. The auxiliary thermostat prevents the temperature from exceeding safe levels by regulating the temperature to a maximum of 300°F. If this occurs, "HIGH" will appear on the keypad; the affected unit should not be used until the cause of the fault is corrected by a qualified service technician.

## TROUBLESHOOTING - continued

2. **Under-Temperature Fault**—An under-temperature fault occurs when the control senses that the shelf temperature is lower than the specified factory preset temperature for more than thirty minutes continuously. This occurs when heating element circuit opens or the RTD Feedback signal is faulty. If this occurs, "LOW" will appear on the keypad and the affected unit should not be used until the cause of the fault is corrected by a qualified service technician.

**Note:** During normal operation the temperature may drop below the preset, due to environmental conditions. When this occurs the actual temperature will be displayed. This condition will be momentary and normal operation will resume shortly. If this should occur frequently or for long periods of time, the affected unit should not be used and you should contact the service hotline.

3. **Sensor Fault** – If at any time during normal operation, "SENS" is displayed on the keypad; discontinue operation and contact a qualified service technician.

### TEMPERATURE CHECK PROCEDURE

1. A digital temperature meter that has been calibrated must be used to get an accurate temperature reading. Use a thermocouple surface temperature probe to measure temperatures.

2. **No pans should be in wells during the pre-heat and temperature check.** Pre-heat the warmer for 30 minutes before taking any temperature readings. Do not take readings unless the cavity has been empty for 30 minutes. This will allow the temperature to stabilize and will prevent false readings.
3. The warmer cavity should be cleaned and empty before the temperature is checked. Avoid any air drafts that might flow through the cavity.

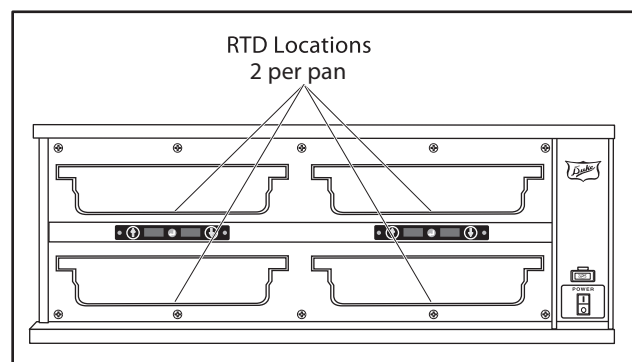

4. Locate the surface temperature probe on the bottom of the cavity, approximately six inches from either end of the cavity. Take temperature readings from both ends of the cavity. Make sure the probe is making good contact with the surface while taking readings.
5. All temperature controls exhibit a swing in temperature as the control cycles on and off while regulating to the set point. The correct calibration temperature is the average of several readings taken over a period of 20 minutes after the warmer has been pre-heated. The average temperature should be  $\pm 5^{\circ}\text{F}$  from the set point.

### SERVICE HOT-LINE

Check the display for fault messages. Perform the Temperature Check Procedure in this manual. Make note of the findings. Please have this data handy before calling the Duke troubleshooting Hot Line listed above. For optimum support, please be near the suspect unit with a cordless phone, if available, when calling our Technicians.

**THIS PAGE LEFT BLANK**

## PARTS LISTS & EXPLODED VIEWS

### HSHU-22 MAIN CABINET - PARTS LIST (FOR REFERENCE ONLY - UNIT TO BE SERVICED BY AUTHORIZED PERSONNEL ONLY)

HSHU ASSY [HSHU-22 SHOWN]						
ITEM	PART NO.	DESCRIPTION	QTY			
			HSHU-22	HSHU-23	HSHU2-22	HSHU-13
1	158512	Asy, SS Faceplate W/Gasket Hshu-22	2		2	
	158513	Asy, SS Faceplate W/Gasket Hshu-23		2		
	158464	Asy, SS Faceplate W/Gasket Hshu-13				2
2	523710	Keypad	2 or 4	3 or 6	2	
	523712	Keypad				2 or 4
3	158359	Wiring Diagram Hshu-22	1		1	
	158360	Wiring Diagram Hshu-23		1		
	158559	Wiring Diagram Hshu-13				1
4	157886	Switch	1	1		1
	156527	Switch			1	
5	156195	Usb Host Adapter	1	1	1	1
6	155749	Transformer [208/240V]	1	1	1	1
	156838	Transformer [230V]	1	1		1
*7	157965	Filter, 16A [CE]	1	1		1
*8	160526	Harness, Filter [CE]	1	1		1
*9	158287	Harness, Main Hshu	1		1	1
	158257	Harness, Main Hshu		1		
*10	156218	Usb Flash Drive	1	1	1	1
*11	158255	Harness, Rtd Hshu	1	1	1	
	158469	Harness, Rtd Hshu				1
*12	512781	Relay [CE]	1	1		1
*13	160506	Thermostat [CE]	1	1		1
*14	158357	Harness, Power Jumper (Non-CE)	1	1		1
	158435	Harness, Power Jumper (Non-CE)			1	
*15	158356	Harness, HSHU Main Power	1	1		1
	158488	Harness, HSHU2 Main Power			1	
*16	160580	Harness, Daypart	1	1	1	
*17	157916	Switch, Daypart	1	1	1	

\* NOT SHOWN

## PARTS LISTS & EXPLODED VIEWS - continued

HSHU-22 MAIN CABINET - EXPLODED VIEW - (FOR REFERENCE ONLY - UNIT TO BE SERVICED BY AUTHORIZED PERSONNEL ONLY)

### HSHU-22 MAIN CABINET - EXPLODED VIEW

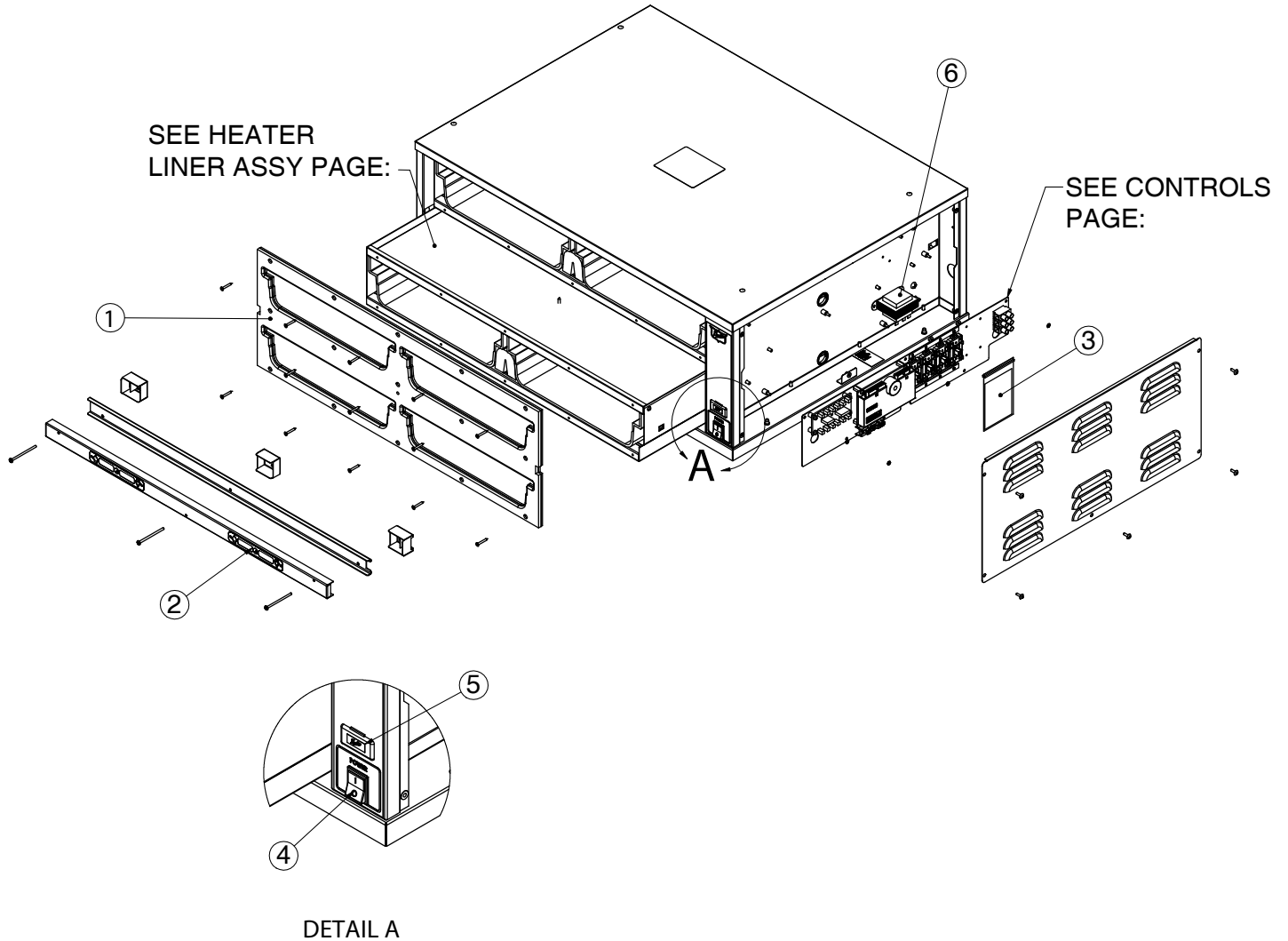

## PARTS LISTS & EXPLODED VIEWS - continued

**HSHU-22 LINER ASSEMBLY - PARTS LIST (FOR REFERENCE ONLY - UNIT TO BE SERVICED BY AUTHORIZED PERSONNEL ONLY)**

<b>HEATER LINER ASSY [HSHU-22 SHOWN]</b>														
Item	Part No.	Desc.	QTY				Components				QTY			
			HSHU 22		HSHU 23		Item	Part No.	Description	208V		230/240V		
			22	13	23	22				13	22	13	22	
1	158275	Assy, Heat Sink HSHU 18" Lead	2	1	2		A	158211	Element, 208V, 300W 22" Lead	1	2			
							A	158329	Element, 230V, 300W 22" Lead			1	2	
							B	158279	RTD, Medium Lead	1	2	1	2	
							C	158312	Thermostat	1	1	1	1	
2	158282	Assy, Heat Sink HSHU 33" Lead	2	1	2		A	158276	Element, 208V, 300W 33" Lead	1	2			
							A	158330	Element, 230V, 300W 33" Lead			1	2	
							B	158279	RTD, Medium Lead	1	2	1	2	
							C	158312	Thermostat	1	1	1	1	
3	158283	Assy, Heat Sink HSHU 48" Lead (not shown)		1	2		A	158277	Element, 208V, 300W 48" Lead	1	2			
							A	158332	Element, 230V, 300W 48" Lead			1	2	
							B	158280	RTD, Long Lead	1	2	1	2	
							C	158312	Thermostat	1	1	1	1	
4	158409	Assy, Heat Sink HSHU 18" Lead				2	A	158211	Element, 208V, 300W 22" Lead		2			
							B	158436	RTD, 1000 OHM		2			
							C	155753	Thermostat		1			
5	158420	Assy, Heat Sink HSHU 32" Lead				2	A	158276	Element, 208V, 300W 33" Lead		2			
							B	158278	RTD, Short Lead		2			
							C	155753	Thermostat		1			

### HSHU-22 LINER ASSEMBLY - EXPLODED VIEW

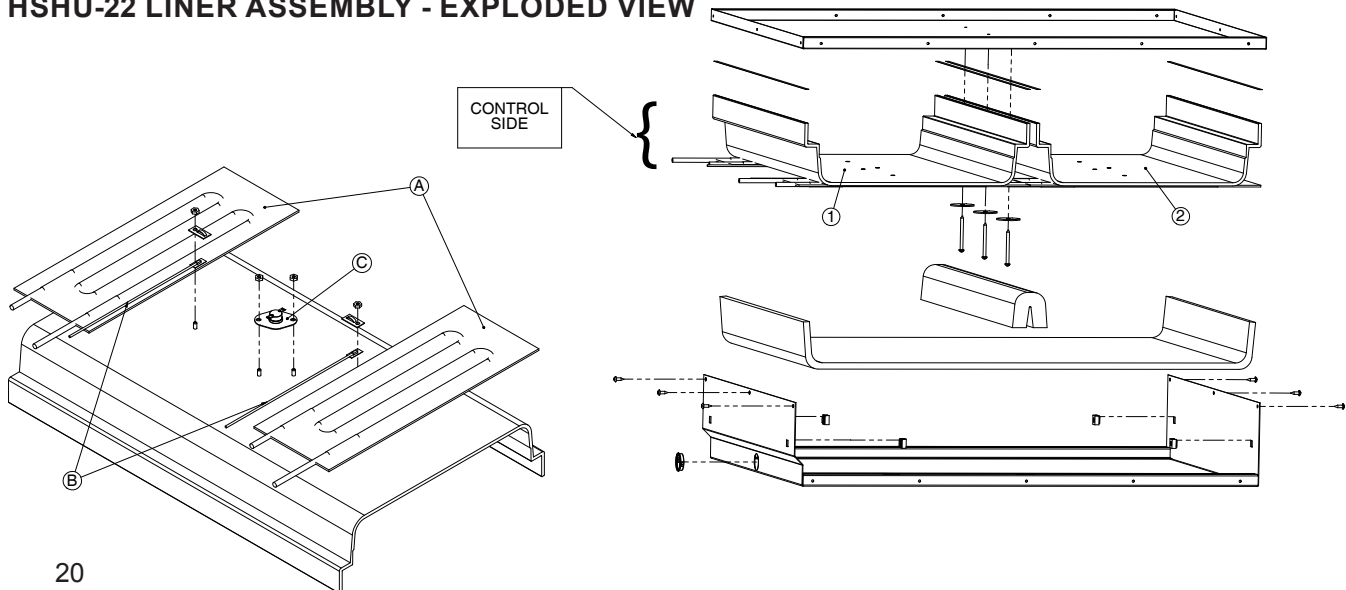

## PARTS LISTS & EXPLODED VIEWS - continued

HSHU-22 CONTROLS - PARTS LIST (FOR REFERENCE ONLY - UNIT TO BE SERVICED BY AUTHORIZED PERSONNEL ONLY)

CONTROLS [HSHU-22 SHOWN]						
ITEM	PART NO.	DESCRIPTION	QTY			
			HSHU-22	HSHU-23	HSHU2-22	HSHU-13
1	158284	RTD Board	1	1	1	1
	158337	RTD Board [CE]	1	1	1	1
2	157743	Terminal Block 8-TAB	1	1	1	1
3	600193	Standard Control Kit	1	1	1	1
4	157830	Relay	4	6	4	3
5	512840	Terminal Block 3-Pos	1	1		1

### HSHU-22 CONTROLS - EXPLODED VIEW

