



OPERATOR'S MANUAL

Your Solutions Partner

DUAL HEATSINK™ HOLDING UNITS

U.S. and Foreign Patents Pending

MODELS

HS2-22-T

HS2-23-T

HS2-24-T

HS2-42-T

HS2-34-T

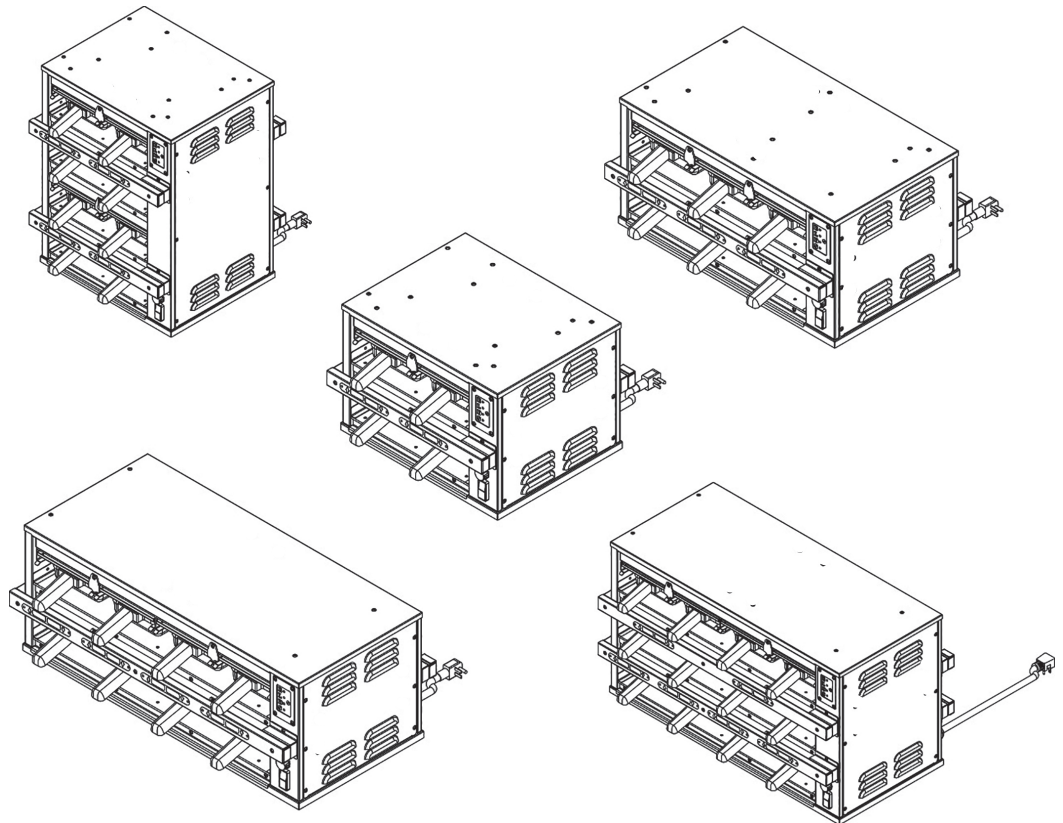

**IMPORTANT INFORMATION, READ BEFORE USE.
PLEASE SAVE THESE INSTRUCTIONS.**

*This manual is Copyright © 2018 Duke Manufacturing Company. All rights reserved.
Reproduction without written permission is prohibited. Duke is a registered
trademark of the Duke Manufacturing Company.*

Duke Manufacturing Company

2305 N. Broadway
St. Louis, MO 63102
Phone: 314-231-1130
Toll Free: 1-800-735-3853
Fax: 314-231-5074
www.dukemfg.com

P/N 229201
REV J 04/16/2018

TABLE OF CONTENTS

Manufacturer's Introduction	3
Important Safety Instructions	4
Installation	5
Temperature Verification	6
Stacking Units	7
Proper Use Of Pan HeatSink™ Cover & Pan Trivets	7
Cleaning Guide	8
HS2-T Operating Instructions	10
HS2 Recipe Configuration Guide	12
HS2 Recipe Download onto a USB Drive	16
Downloading the Recipe to the HS2 Unit	17
Renaming Recipe Files	19
HS2-T Fault Displays on Timer Bars	20
Parts Lists And Illustrations	21
HS2-2X2 Specifications	22
HS2-2X2 Wiring Schematics	23
HS2-2X3 Specifications	24
HS2-2X3 Wiring Schematics	25
HS2-2X4 Specifications	26
HS2-2X4 Wiring Schematics	27
HS2-4X2 Specifications	28
HS2-4X2 Wiring Schematics	29
HS2-3X4 Specifications	30
HS2-3X4 Wiring Schematics	31

MANUFACTURER'S INTRODUCTION

The HS2 Holding Unit was developed specifically to address the needs of restaurant operations and profitability. Extended hold times with improved food quality and consistency were achieved through the innovative, **top and bottom patented Duke technology HeatSink's™**. This gives you the ability to maintain gold standard sensory attributes at significantly extended hold times while delivering hotter food to your customers.

In addition to providing the most robust and reliable solution technically possible, we also made the following improvements from the previous FWM PHU model:

- Changed to a more robust Duke timer bar and control system on HS2-T models
- Eliminated plastic lids and replaced with a robust Stainless Steel Pan HeatSink™ Cover for broiled foods
- Incorporated advanced grease migration controls
- Eliminated plastic faceplate and plastic lid capture system

Throughout this manual, you will uncover more details about the benefits and advantages that the Duke HS2 will bring to your restaurant. Thank you for your purchase and as always, your feedback is appreciated.

IMPORTANT SAFETY INSTRUCTIONS

Throughout this manual, you will find the following safety words and symbols that signify important safety issues with regards to operating or maintaining the equipment.



Indicates a hazardous situation which, if not avoided, could result in death or serious injury.



Indicates a hazardous situation which, if not avoided, could result in minor or moderate injury.



Indicates Important Information



Indicates electrical shock hazard which, if not avoided, could result in death or serious injury and/or equipment damage.



Indicates hot surface which, if not avoided, could result in minor or moderate injury.

In addition to the warnings and cautions in this manual, use the following guidelines for safe operation of the unit.

- Read all instructions before using equipment.
- For your safety, the equipment is furnished with a properly grounded cord connector. Do not attempt to defeat the grounded connector.
- Install or locate the equipment only for its intended use as described in this manual.
- Do not use corrosive chemicals in this equipment.
- Do not operate this equipment if it has a damaged cord or plug, if it is not working properly, or if it has been damaged or dropped.
- This equipment should be serviced by qualified personnel only. Contact the nearest Duke authorized service facility for adjustment or repair.
- Do not block or cover any openings on the unit.
- Do not immerse cord or plug in water.
- Keep cord away from heated surfaces.
- Do not allow cord to hang over edge of table or counter.

The following warnings and cautions appear throughout this manual and should be carefully observed.

- Turn the unit off, disconnect the power source and allow unit to cool down before performing any service or maintenance on the unit.
- The procedures in this manual may include the use of chemical products. You must read the Material Safety Data Sheets before using any of these products.
- The unit should be grounded according to local electrical codes to prevent the possibility of electrical shock. It requires a grounded receptacle with dedicated electrical lines, protected by fuses or circuit breaker of the proper rating, in accordance with all applicable regulations.
- Disposal of the unit must be in accordance with local environmental codes and/or any other applicable codes.
- This appliance is not intended for use by persons (including children) with reduced physical, sensory or mental capabilities, or lack of experience and knowledge, unless they have been given supervision or instruction concerning use of the appliance by a person responsible for their safety.

INSTALLATION

UNPACKING UNIT

Inspect the shipping carton and/or container, carefully noting any exterior damage on the delivery receipt; also note any damage not evident on the outside of the shipping container (concealed damage). Contact the carrier immediately and file a damage claim with them. Save all packing materials when filing a claim. Freight damage claims are the responsibility of the purchaser and are not covered by the warranty.

- Follow the instructions on the Carton Box for unpacking the unit.
- Inspect unit for damage.
- Report any dents or breakage to source of purchase immediately.
- **Do not attempt to use unit if damaged.**
- Remove all materials from unit interior.
- If unit has been stored in extremely cold area, wait a few hours before connecting power.

INSTALLATION CODES AND STANDARDS

In the United States, the HS2 must be installed in accordance with the following:

1. State and local codes.
2. National Electrical Code (ANSI/NFPA No. 70, latest edition) available from the National Fire Protection Association, Batterymarch Park, Quincy, MA 02269.
3. Vapor Removal from Cooking Equipment, (NFPA-96, latest edition) available from NFPA.
4. Sealed to the counter upon which the equipment is placed per NSF/ANSI 4 standard.

In Canada, the HS2 must be installed in accordance with the following:

1. Local codes.
2. Canadian Electrical Code (CSA C22.2 No. 3, latest edition) available from the Canadian Standards Association, 5060 Spectrum Way, Mississauga, Ontario, Canada L4W 5N6.

UNIT PLACEMENT

- Do not install unit next to, below or above source of heat such as oven or deep fat fryer.
- Install unit on level counter top surface.
- Outlet should be located so that plug is accessible when the unit is in place.
- Do not install unit in the direct path of air-conditioned airflow.

The following minimum clearances must be maintained between the warmer and any combustible or non-combustible substance:

Unit	Clearance
Right Side	2"
Left Side	2"
Rear	OPEN
Floor	0"

Proper airflow around unit will cool the electrical components. With restricted airflow, the unit may not operate properly and the life of the electrical components may be reduced. A 2" clearance is recommended at the control side for longer control life expectancy.



ELECTRICAL SHOCK HAZARD UNIT MUST BE SAFETY GROUNDED, EARTHED. DO NOT MODIFY, DEFEAT ELECTRICAL CONNECTIONS OR ALTER PLUG.

ELECTRICAL CONNECTIONS

⚠ WARNING BEFORE CONNECTING THE UNIT TO THE POWER SOURCE, VERIFY THAT THE VOLTAGE AND PHASE OF THE POWER SOURCE ARE IDENTICAL TO THE VOLTAGE AND PHASE INFORMATION ON THE DATA LABEL.

EARTHING INSTRUCTIONS

THE UNIT MUST BE GROUNDED. Grounding reduces risk of electric shock by providing an escape wire for the electric current if an electrical short occurs. This unit is equipped with a cord having a grounding wire with a grounding plug. The plug must be plugged into a receptacle that is properly installed and grounded.

Consult a qualified electrician or service agent if grounding instructions are not completely understood, or if doubt exists as to whether the unit is properly grounded.

DO NOT USE AN EXTENSION CORD. If the product power cord is too short, have a qualified electrician install a three-slot receptacle (or the country specific receptacle for International Units). This unit should be plugged into a dedicated circuit with the electrical rating as provided on the product data plate.

TEMPERATURE CHECK PROCEDURE

1. A digital temperature meter that has been calibrated must be used to get an accurate temperature reading. Use a thermocouple surface temperature probe to measure temperatures.
2. **No pans should be in wells during the pre-heat and temperature check.** Pre-heat the warmer for 30 minutes before taking any temperature readings. Do not take readings unless the cavity has been empty for 30 minutes. This will allow the temperature to stabilize and will prevent false readings.
3. The warmer cavity should be cleaned and empty before the temperature is checked. Avoid any air drafts that might flow through the cavity.
4. Temperature readings should be taken when standing on the front side of the unit with on/off switch. Locate the surface temperature probe on the bottom or top of the first cavity. Position the probe half way back on the heat sink beneath the rail as shown. The top readings should be taken on either side of the rail half way back on the heat sink. Four wide units require 2 readings, left and right side.

NOTE: For 2x3 four (4) zone units refer to Fig 3.

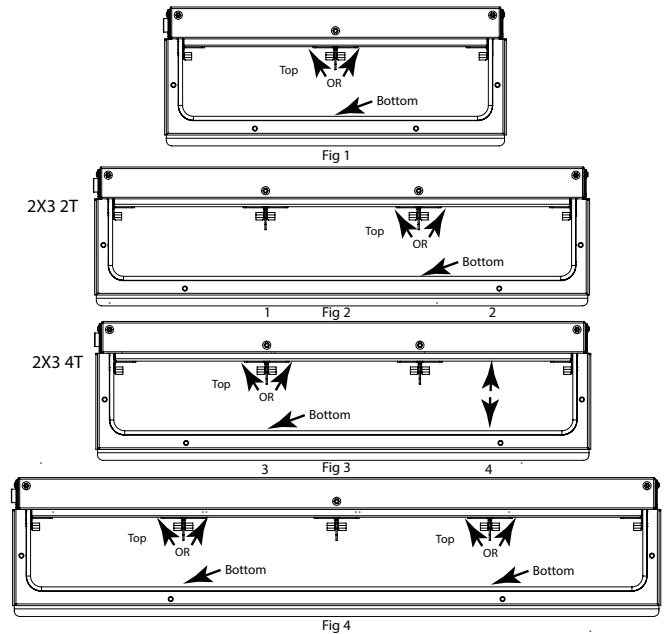

5. All temperature controls exhibit a swing in temperature as the control cycles on and off while regulating to the set point. The correct calibration temperature is the average of several readings taken over a period of 20 minutes after the warmer has been pre-heated. The average temperature should be no greater than $\pm 10^{\circ}\text{F}$ ($\pm 6^{\circ}\text{C}$) from the set point.
6. The allowable range of well temperatures which can be programmed on the HS2 is 140°F - 280°F (60°C - 137.8°C).

STACKING UNITS

The HS2 Holding Unit is designed to allow limited stacking capabilities. This section outlines how to safely stack the holding unit.

- Step 1** Remove the base pan from the unit that will be on top. The pan is held in place by four screws on the bottom of the unit.

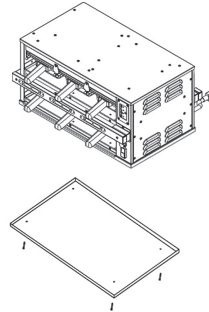

- Step 2** Place bottom unit into position then stack the next unit on top. The top of the lower holding unit rests inside of the base of the upper unit.

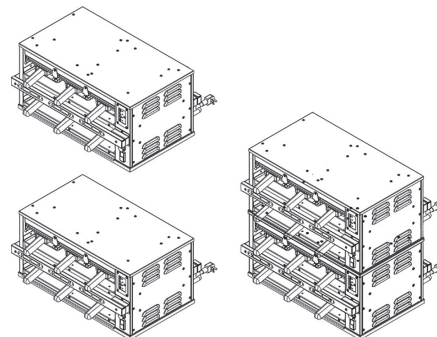

⚠ WARNING TIP HAZARD! DO NOT STACK HS2-42 OR HS2-34 UNITS. DO NOT EXCEED 2 HOLDING UNITS PER STACK. DO NOT PLACE HOLDING UNIT STACKS ON SURFACES THAT MAY EASILY TIP OVER.

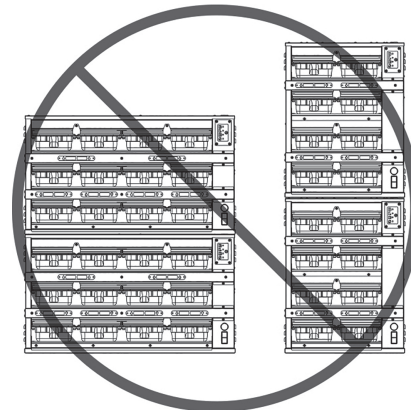

PROPER USE OF HEATSINK™ COVERS & PAN TRIVETS

Proper usage of each is important and is outlined below:

Product Type	Duke Pan Heat Sink Cover
Broiled	yes
Fried	no

Consult your Kitchen Operations Manual for any modifications to the above based on your specific food requirements.

CLEANING GUIDE



Electrical shock hazard. Do not wash with water jet or hose. DO NOT USE CAUSTIC CLEANERS, ACIDS, AMMONIA PRODUCTS OR ABRASIVE CLEANERS OR ABRASIVE CLOTHS. THESE CAN DAMAGE THE STAINLESS STEEL AND PLASTIC SURFACES.



Bottom and sides of warmer wells are very hot and cool slowly.

DAILY CLEANING

- Stainless Steel Surfaces

To prevent discoloration or rust on stainless steel several important steps need to be taken. Stainless steel contains 70-80% iron which will rust. It also contains 12-30% chromium which forms an invisible passive film over the steel surface which acts as a shield against corrosion. As long as the protective layer is intact, the metal will not corrode. If the film is broken or contaminated, outside elements can begin to breakdown the steel and begin to form rust or discoloration.

Proper cleaning of stainless steel requires soft cloths or plastic scouring pads.



Never use steel pads, wire brushes or scrapers.

Cleaning solutions need to be alkaline based or non-chloride cleaners. Any cleaner containing chlorides will damage the protective film of the stainless steel. Chlorides are also commonly found in hard water, salts and household and industrial cleaners. If cleaners containing chlorides are used, be sure to rinse repeatedly and dry thoroughly upon completion.

Routine cleaning of stainless steel can be done with soap and water. Extreme stains or grease should be cleaned with a non-abrasive cleaner and plastic scrub pad. It is always good to rub with the grain of the steel. There are also stainless steel cleaners available which can restore and preserve the finish of the steels protective layer.

Early signs of stainless steel breakdown can consist of small pits and cracks. If this has begun, clean thoroughly and start to apply stainless steel cleaners in an attempt to restore the passivity of steel.



NEVER USE AN ACID BASED CLEANING SOLUTION! MANY FOOD PRODUCTS HAVE AN ACIDIC CONTENT WHICH CAN DETERIORATE THE FINISH. BE SURE TO CLEAN ALL FOOD PRODUCTS FROM ANY STAINLESS STEEL SURFACE. COMMON ITEMS INCLUDE, TOMATOES, PEPPERS AND OTHER VEGETABLES.



THE POWER MUST BE TURNED OFF AND DISCONNECTED AT ALL TIMES WHEN PERFORMING MAINTENANCE OR REPAIR FUNCTIONS.



NEVER USE A HIGH-PRESSURE WATER WASH FOR THIS CLEANING PROCEDURE AS WATER CAN DAMAGE ELECTRICAL COMPONENTS



ELECTRICAL SHOCK HAZARD. DO NOT WASH WITH WATER JET OR HOSE.

RECOMMENDED SUPPLIES

Cleaning Towels

Non-Scratch Scrub Pad

KAY™ Degreaser

KAY® SINK SANITIZER, KAYQUAT™ Sanitizer, or compatible sanitizer

PROCEDURE

1. Turn unit off, unplug, and allow to cool for 30 minutes.
2. Remove all holding pans and heat sink covers. Wash, rinse, and sanitize at the 3 compartment sink.
3. Allow to air dry.
4. Spray a cleaning towel, or non-scratch scrub pad when necessary, with soapy solution or KAY™ Degreaser. Fully clean upper heat sink surfaces by hand, as well as lower heat sink surfaces.

 **CAUTION** Take care when reaching in the cabinet. Pan and lid guides present sheet metal edges which could be sharp.

NOTE: Never spray cleaning solution directly onto the cabinet.

5. If daily cleaning is performed routinely, deeper, more aggressive, cleaning methods can be avoided. Over longer periods of time, fried food product can accumulate and bake on to the upper heat sink surfaces of the compartments.
6. Use a sanitizer-soaked towel and wipe out all compartments on the holding unit. Wipe top compartments first, and then lower compartments.

IMPORTANT: Use clean, sanitizer-soaked towels (Important: towels must be wrung out so that they are damp and not dripping, dripping towels may harm the unit.)

DAILY INSPECTION CHECKLIST:

Make sure that:

- Unit is free of any visible food soils.
- Unit is free of grease or soils in holding compartment.
- Exterior of unit is free of smudges or soil.
- Holding pans are free of any food soil residue.
- Pans are free of damage such as cracks.

HS2-T OPERATING INSTRUCTIONS

TO ENSURE OPTIMAL HOLD QUALITY, THE USER WOULD PRESS THE BUTTON ON THE TIMER BAR CORRESPONDING WITH THE PAN LOCATION TO ACTIVATE A HOLD CYCLE. THIS STARTS THE TIMER COUNTDOWN.

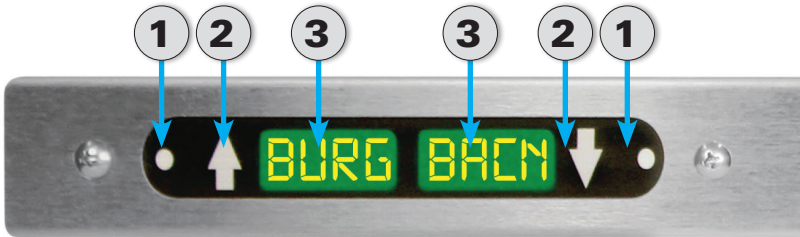

1. Status LED's: Indicates status of the pan

- Non-Illuminated – timer is inactive – *no product in pan.*
- Green – timer is active – *product in pan (use 1ST)*
- Amber – timer is active – *product in pan (use next)*
- Non-Illuminated – timer active – *product in pan (use later)*
- Flashing Green – *cook warning time reached (cook more product)*
- Flashing Red – *product is expired (discard)*

2. Arrow buttons

- Used for starting and stopping the timer
- Used to access menu mode
- Indicates which pan the adjacent status LED and pan display are linked to

3. Pan Display

- In startup mode it will display spinning bars then transition to PRE HEAT, and then cycle through the bottom actual temp and top actual temp
- Once unit reaches the recipe set points it will display product name. (If associated recipe requires a lid display will toggle prod name, lid.)
- Unit will display product name and hold time remaining (display will alternate between the two when a timer is active)

- ENSURE PROPER HEAT SINK COVERS ARE INSERTED INTO THE CORRECT LOCATION (BROILED AND MOISTURE SENSITIVE PRODUCTS ONLY).
- ENSURE METAL TRIVETS ARE INSERTED INTO THE PANS FOR FRIED PRODUCTS.
- UPON TURNING ON, ALLOW THE HOLDING UNIT TO HEAT FOR AT LEAST 30 MINUTES OR UNTIL THE TEMPERATURE **DISAPPEARS** AND THE TIMER BARS **DISPLAY** THE PREPROGRAMMED PRODUCT NAMES.
- IF THE TIMER BARS **DISPLAY** "HIGH" OR "LOW" AT ANY TIME AFTER THE PRE-HEAT PERIOD, **DISCONTINUE** USE OF THE AFFECTED PAN LOCATION(S) UNTIL THE HOLDING UNIT CAN BE SERVICED.

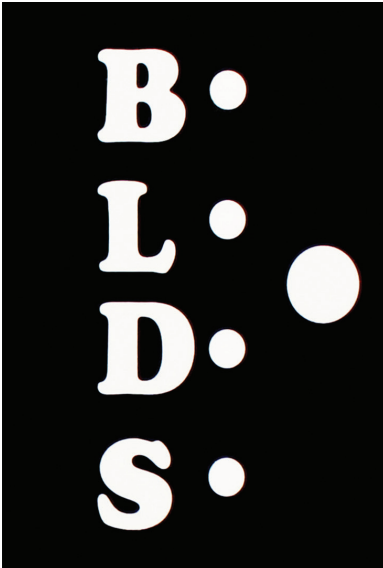

PUSHING THIS BUTTON WILL CYCLE THE UNIT THROUGH THE DIFFERENT DAYPARTS AND SHOW PRODUCTS ASSOCIATED WITH EACH MENU.

- **B** – Breakfast
- **L** – Lunch
- **D** – Dinner
- **S** – Snack

Menu Mode

1. Press and hold the paired arrows for a display segment for 3 seconds to enter Menu Mode. Display will toggle (NAME, product name)
2. 1ST button press will display (ACT TEMP, actual temp bottom, actual temp top)
3. 2ND button press will display (SET TEMP, temp set point bottom, temp set point top)
4. 3RD button press will display (TIME, receptive in minutes)
5. 4TH button press will display (LID, ON or OFF)
6. 5TH button press will display (COOK MORE TIME, cook more time in minutes)
7. 6TH button press will display (FIRM, actual firmware version)
8. 7TH button press will display (LED display will light all LEDs in a testing sequence)

HS2 Recipe Configuration Guide

To log onto the Duke HS2 configurator use the following address: phuconfig.dukemfg.com/login

- Type in the supplied user name in the first text box.
- Type the password in the second text box
- Click on “Login”

Note: When typing in the password it will show a series of “dots” the password will be hidden. The user name and password are case sensitive, use only lower case letters.

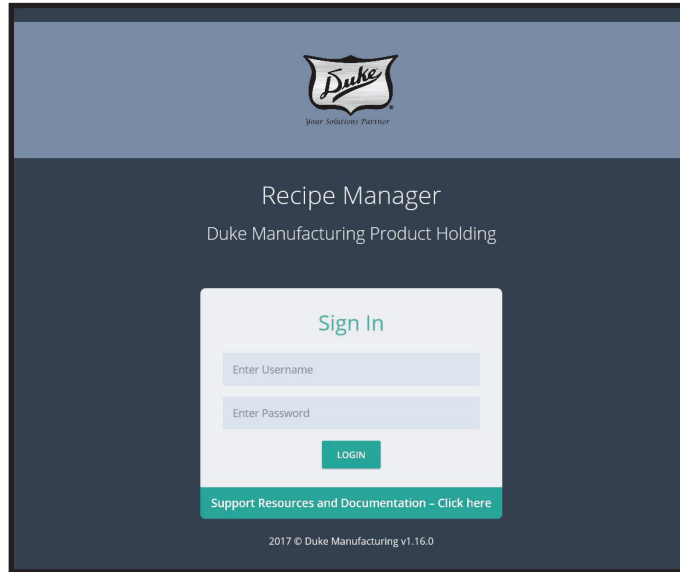

After login, the screen will show the “Configure HS2” icon as shown to the right. Click the ICON to open up the HS2 configurator.

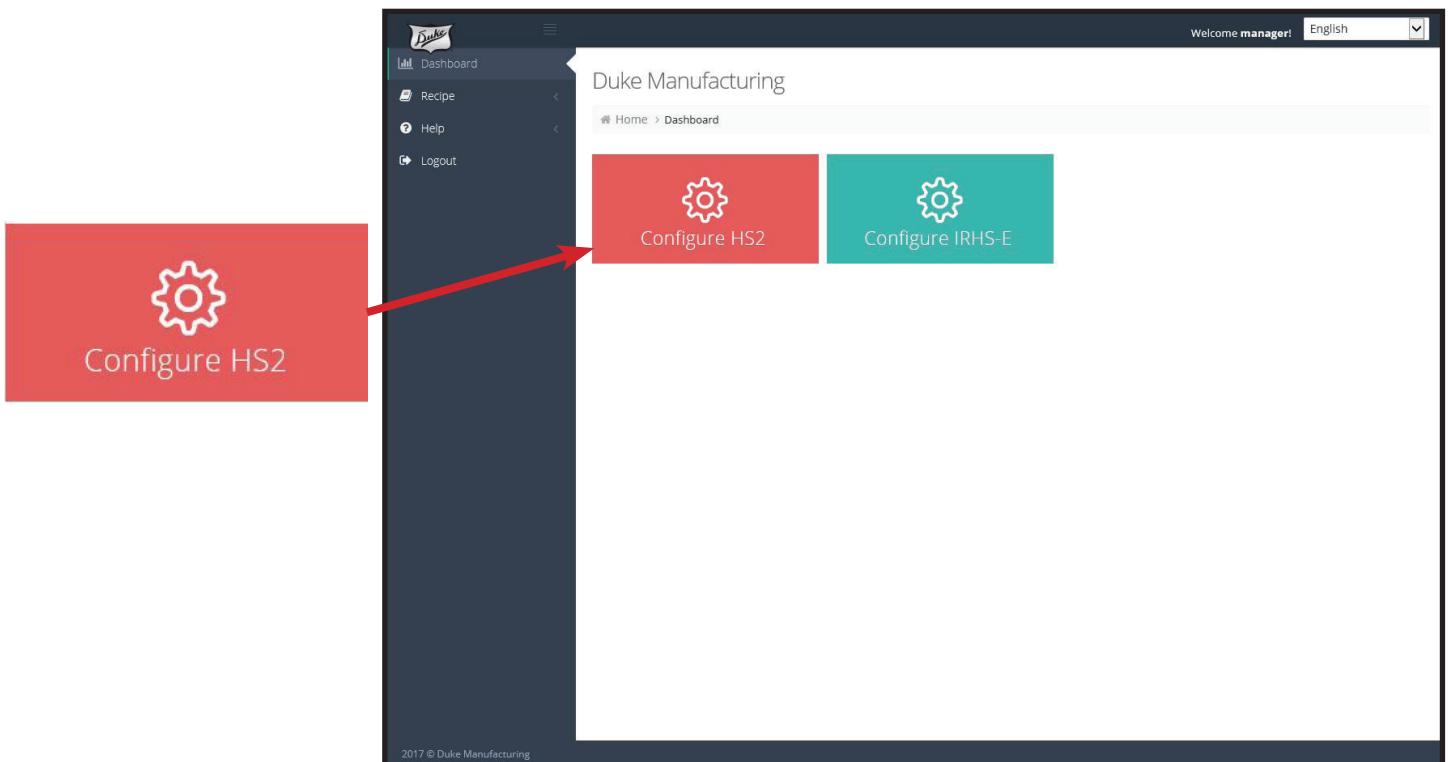

HS2 Recipe Configuration Guide Continued

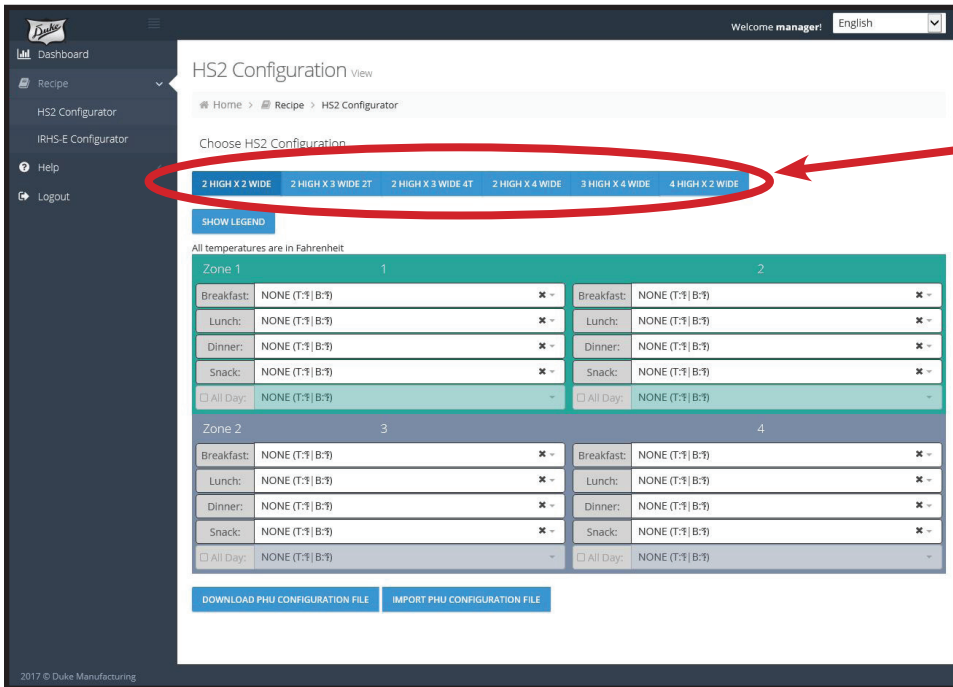

The configurator page will open on the screen.

Choose the size of unit you wish to program.

Note: If programming an HS2 2X3 unit you must choose between version 2T or 4T . See below for instructions on how to find which unit you have.



When programming an HS2 2X3 there are two versions. To determine which version that you have, locate the data tag located on the side of the unit. Look for the 2T or 4T designation under the model number as shown in the two samples below. Then click on correct 2X3 on the configuration to open the recipe setup.



HS2X3 2T

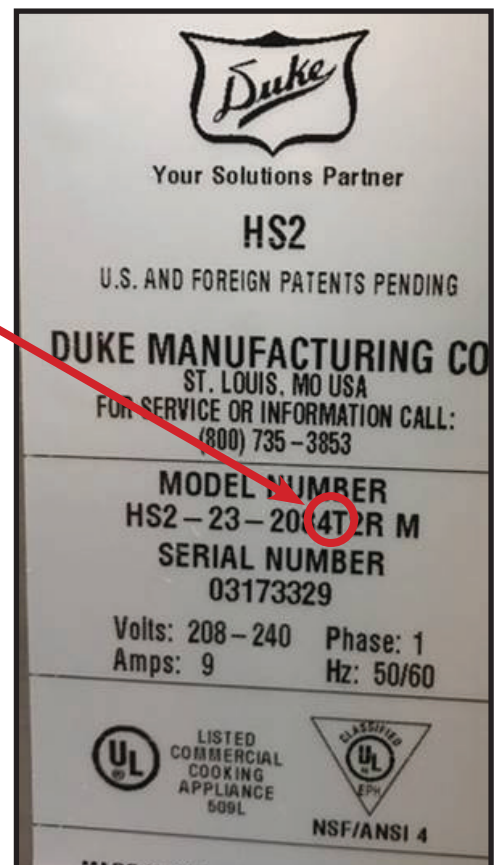

HS2X3 4T

HS2 Recipe Configuration Guide Continued

Product Code Legend

When populating the configurator a drop down legend is available to show the four digit timer bar code with a product description.

Click on the “SHOW LEGEND” box to display the legend.

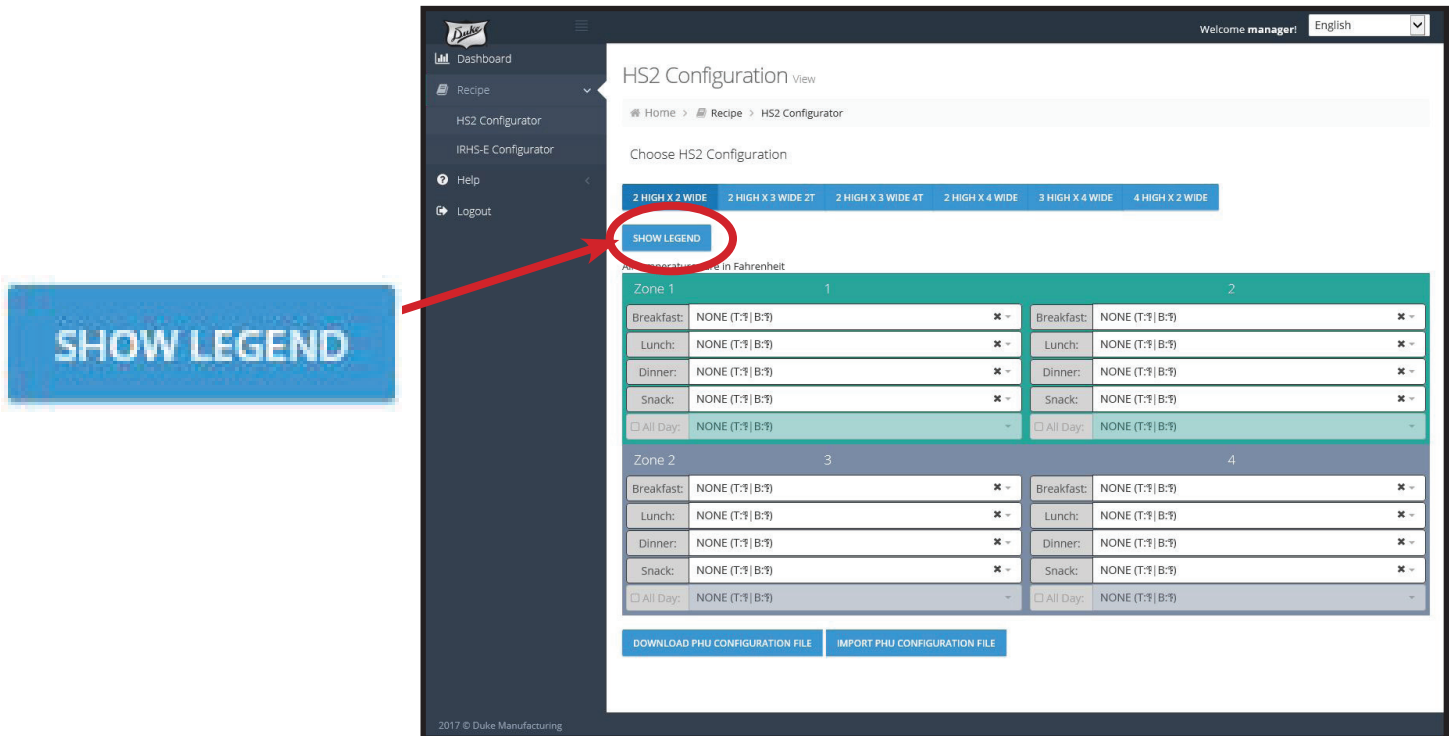

The screenshot shows the HS2 Configuration view in a web browser. The left sidebar contains navigation options: Dashboard, Recipe, HS2 Configurator, IRHS-E Configurator, Help, and Logout. The main content area is titled "HS2 Configuration view" and includes a breadcrumb trail: Home > Recipe > HS2 Configurator. Below the breadcrumb, there is a section "Choose HS2 Configuration" with several tabs: 2 HIGH X 2 WIDE, 2 HIGH X 3 WIDE 2T, 2 HIGH X 3 WIDE 4T, 2 HIGH X 4 WIDE, 3 HIGH X 4 WIDE, and 4 HIGH X 2 WIDE. The "SHOW LEGEND" button is circled in red. Below this, there are four zones (Zone 1, Zone 2, Zone 3, Zone 4) each with a table of meal options (Breakfast, Lunch, Dinner, Snack, All Day) and their corresponding product codes. At the bottom, there are buttons for "DOWNLOAD PHU CONFIGURATION FILE" and "IMPORT PHU CONFIGURATION FILE".

To hide the legend just click on “HIDE LEGEND”

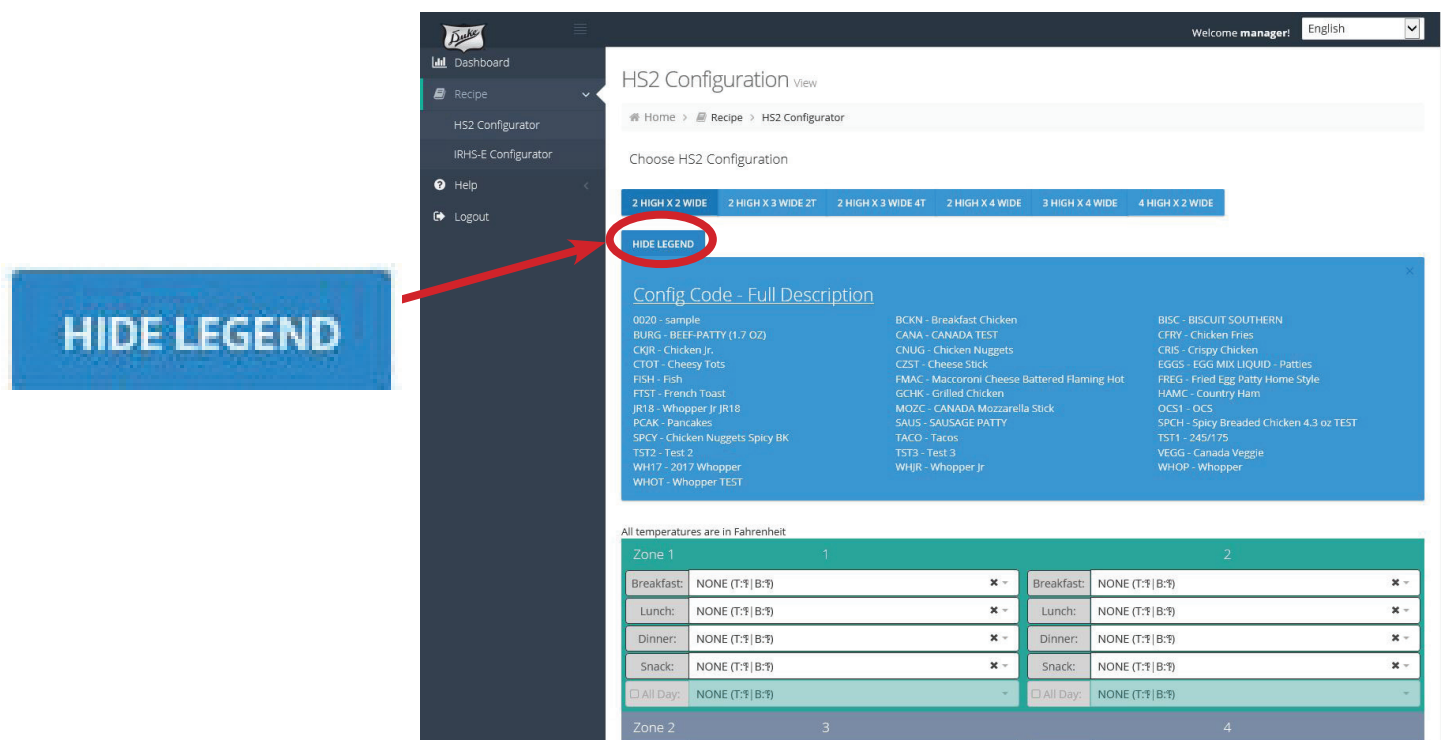

The screenshot shows the HS2 Configuration view with the "HIDE LEGEND" button circled in red. A callout box on the left contains the text "HIDE LEGEND". The main content area now displays a "Config Code - Full Description" table with three columns of product codes and descriptions. Below the table, there is a note "All temperatures are in Fahrenheit" and the same four-zone configuration table as in the previous screenshot.

HS2 Recipe Configuration Guide Continued

Click the correct box for the HS2 model to be programmed and the wells will show up on the screen ready to program.

The wells will be divided into zones.



Using the drop down for each day part the recipes choices will appear.

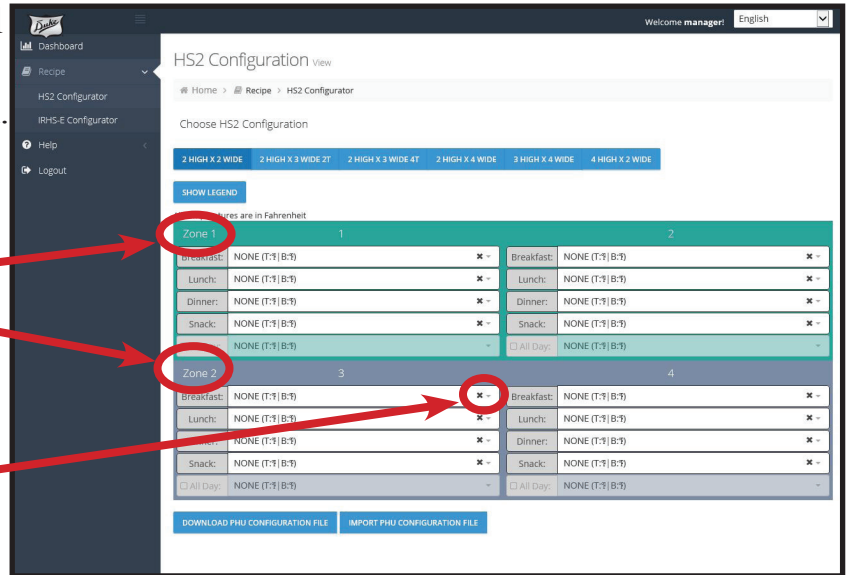

Select the recipe you wish to place for each well and for each day part.

You can start with either well (left or right in each zone). Once a well has been populated the adjacent well within the same zone can be left empty or a product with a similar temperature setting will appear on the drop down. There are four day parts that can be populated which are Breakfast, Lunch, Dinner and Snack.

An additional choice for each zone is “All Day Parts” when choosing this option the same product will be assigned for all four day parts. You will need to assign each well in the zone.

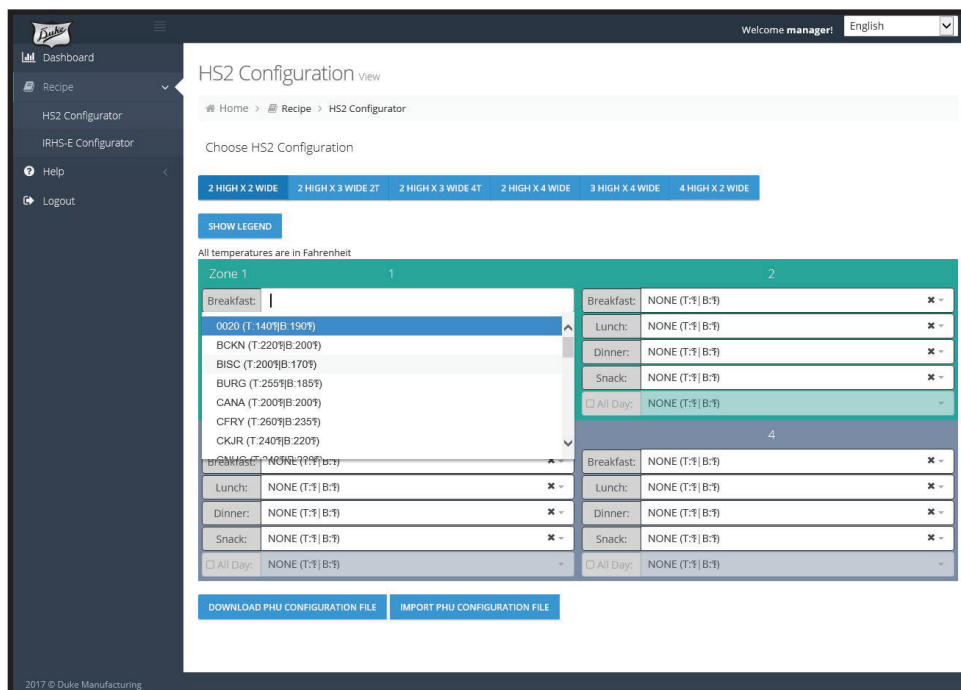

Recipe Download onto a USB Drive

Using a clean USB drive insert into your computer. Make sure there aren't any other files on the drive. The files are small so any size USB drive will work.

Create the following folder: RCP_LOAD

The recipe file to be downloaded from the configurator will need to be inserted into the RCP_LOAD folder.

When inserted into the HS2 unit, the unit will be searching for this specific RCP_LOAD folder and download the file that is saved in that folder.

Note: It is important that only one file be saved in the folder.

Once the configurator has been populated with all the products to be held in the HS2 (sample shows zone 1 populates using "All Day Parts" and zone 2 populated using different products for all four day parts.

Click on the:

DOWNLOAD PHU CONFIGURATION FILE

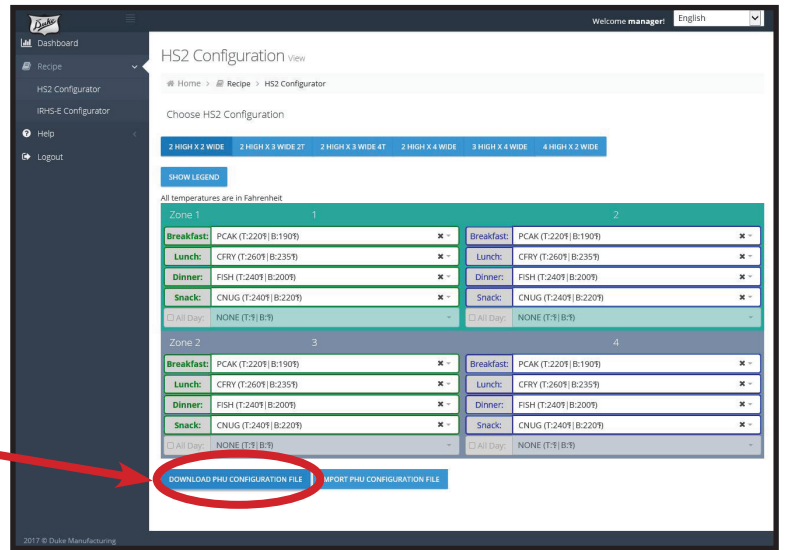

The text box below will open at the bottom of your screen. Click on the arrow down next to save.

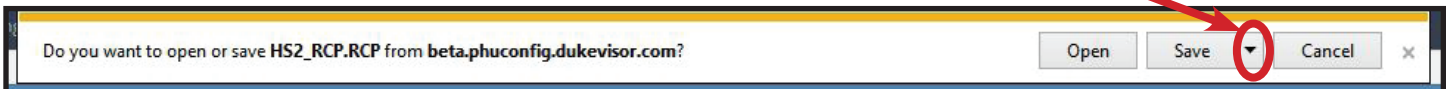

Click on the "Save As" box.

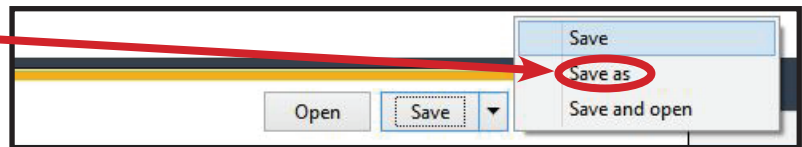

The window on the right will open.

Locate and open "Removable Disc"

The folder "RCP_LOAD" should appear.

Note: If you have not created the folder RCP_LOAD, create it now.

Open the RCP_LOAD folder.

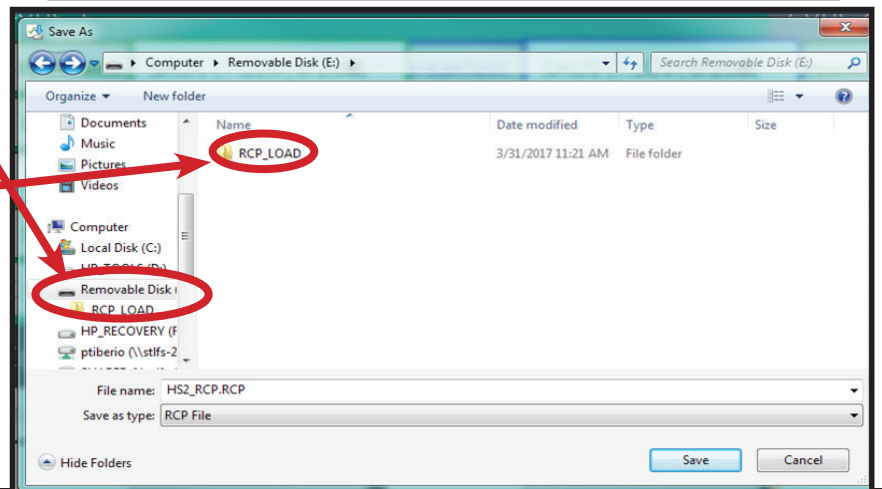

Recipe Download onto a USB Drive

With the RCP_LOAD folder open click on the “SAVE” button.

The window will close and the file has been saved in the folder ready to be downloaded into the HS2 unit.

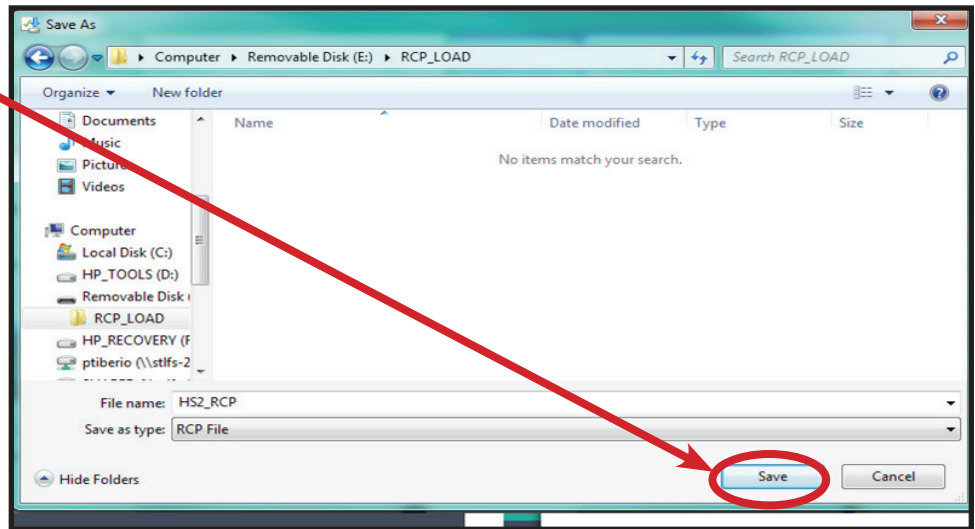

With the recipe file saved in the RCP_LOAD folder of your USB drive, remove the USB Drive from the computer and take it to the HS2 unit that you wish to download the recipe file onto.

Downloading the Recipe to the HS2 Unit

Before inserting the USB drive into the HS2 unit it is important to make sure the unit is already powered up. If not, power up the unit.



After the HS2 has been powered up the timer bars will show lines (see to the Right) and the lines will rotate until the unit is ready for preheat.



Downloading the Recipe to the HS2 Unit

When the unit is ready to download the recipe file the timer bar will show letters and/or numbers on the display.

Make sure that all timer bars no longer show any rotating lines as illustrated earlier. It may take several minutes for the rotating lines to disappear. Once all the lines have disappeared the unit is ready to accept the recipe file.



When the unit is ready to download the recipe locate the USB port.

Insert the USB Drive. Once inserted properly there will be a series of two loud beeps.

Wait 15 seconds after the second beep and remove the USB drive.

You will notice that the timer bars will flash after the second beep, which is an indication that the recipe file has been properly accepted.

The HS2 will either show "PRE" on the display if the unit is not up to temperature, or will indicate the product for each well of the new recipe.



The HS2 may be equipped with an optional "Daypart Switch" which allows the operator to store four different recipe settings. The recipes would have been downloaded onto the recipe file while the configurator was being set up.

B = Breakfast

L = Lunch

D = Dinner

S = Snack

To switch Daypart depress the button (Circled in Red) and toggle to the Daypart you wish. The HS2 will then load the recipe items for each well as setup in the configurator.

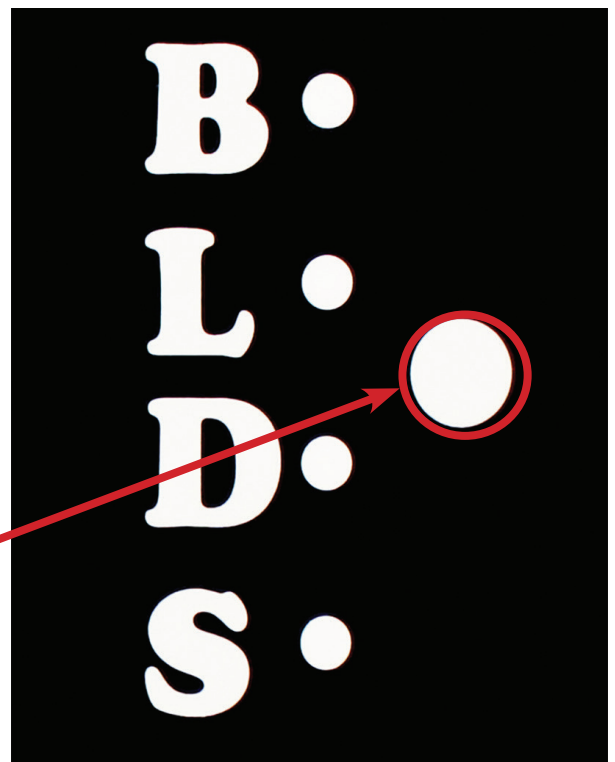

Renaming Recipe Files

Recipe files may be renamed. This is useful if there are multiple HS2 units at your location that will house different products for different HS2 sizes. These files may also be saved on the same USB drive.

Caution: If saving multiple files on the same drive do not locate the files inside the folder named “RCP_LOAD” save them outside the folder.

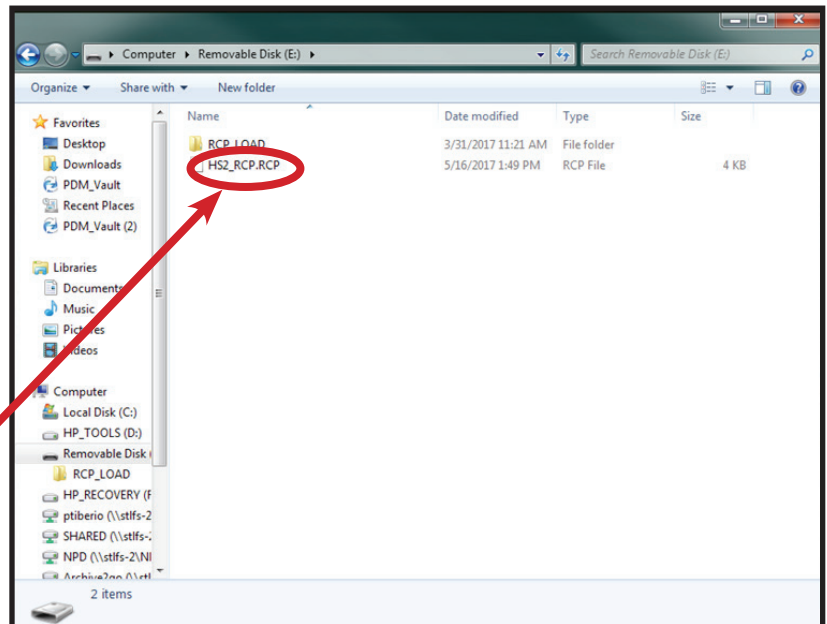

Highlight the file to be renamed, Right click on the file then click on “Rename”. You may choose letters or numbers up to a total of 8 characters. This does not include .RCP which must at the end of the file name.

Example: HS2_RCP.RCP can be re-named ABCD1234.RCP.

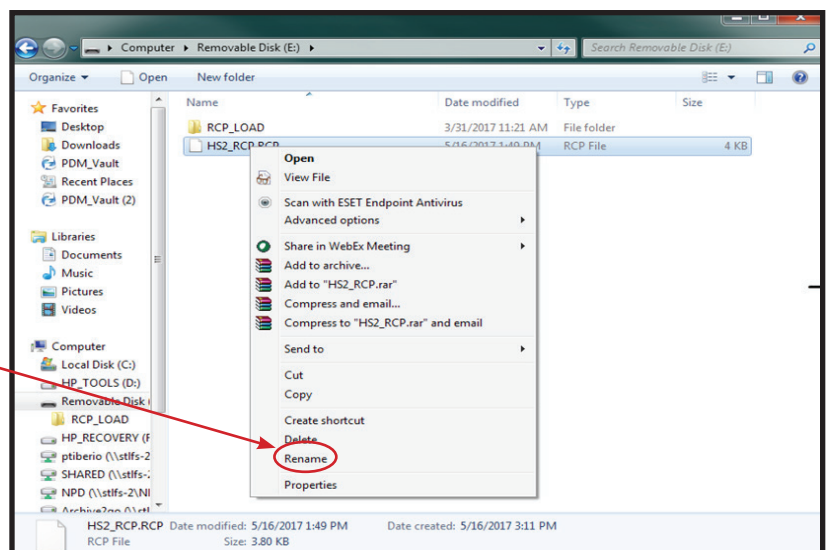

The HS2 will only download onto the HS2 the recipe that resides **inside** the RCP_LOAD folder.

Drag and drop the required recipe into the RCP_LOAD folder prior to inserting into the USB port of the HS2.

Note: It is important that only one recipe file (of any type) reside in the RCP_LOAD folder or the download will be rejected and an error condition will be displayed on the HS2 timer bar.

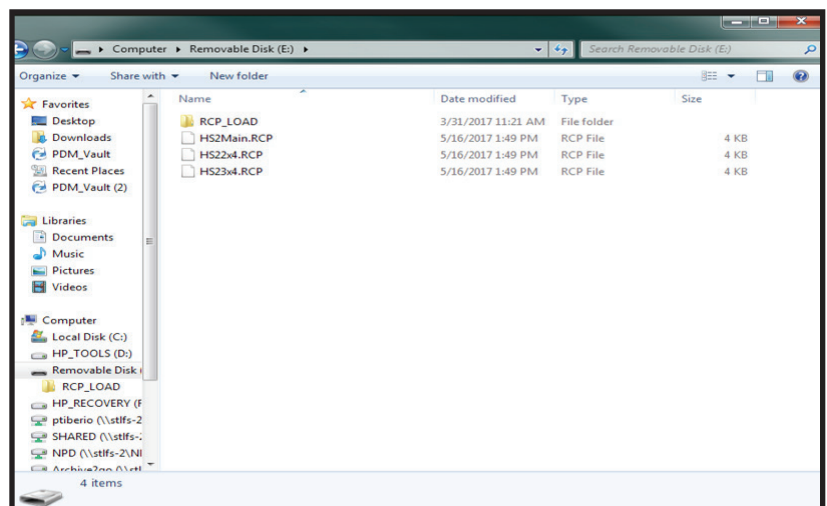

HS2-T FAULT DISPLAYS

Fault:	Display Toggle:	Cause:
Bottom Heater Fault Low	"HTR/FALT/LOW/BOT"	Temperature is 20 below set point for over 10 minutes
Top Heater Fault Low	"HTR/FALT/LOW/TOP"	Temperature is 20 below set point for over 10 minutes
Bottom Heater Fault High	"HTR/FALT/HIGH/BOT"	Temperature is 40 above set point for over 10 minutes
Top Heater Fault High	"HTR/FALT/HIGH/TOP"	Temperature is 40 above set point for over 10 minutes
CAN Error	"CAN/ERR"	IO3 board missing from CAN bus
IO3 Board Configuration Fault	"IO3/CNFG/FALT"	IO3 board DIP switch setting error
TOP Temperature Sensor Fault	"TOP/TEMP/SENS/FALT"	Top heat RTD temperature sensor is shorted or open/missing
Bottom Temperature Sensor Fault	"BOT/TEMP/SENS/FALT"	Bottom heat RTD temperature sensor is shorted or open/missing

PARTS LIST AND ILLUSTRATIONS

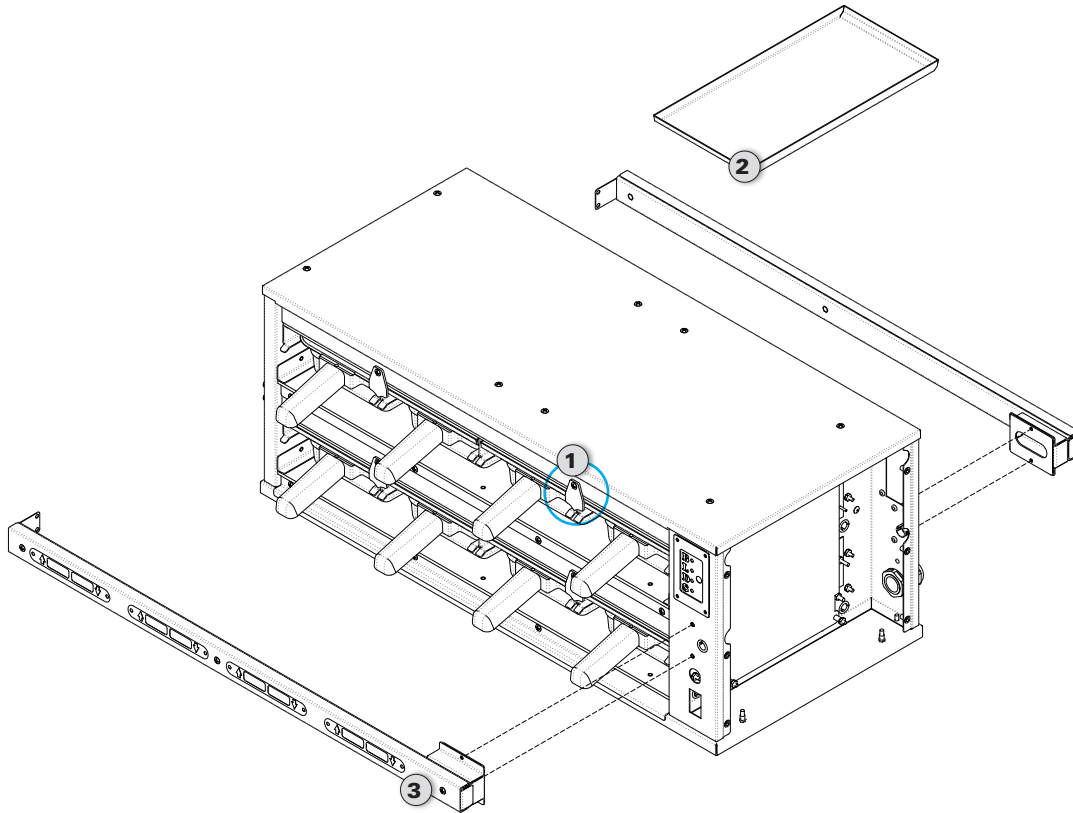

	P/N	Part	Qty Per Unit				
			2X2	2X3	2X4	4X2	3X4
1	1059-0499	COVER STOP	4	8	8	6	12
2	1059-0498	LID	AR***	AR***	AR***	AR***	AR***
3	1059-0474	2X2 TIMER BAR FRONT <i>ASY MENU BAR 2W</i>	1	NA	NA	NA	NA
	1059-0474	2X2 TIMER BAR REAR <i>ASY MENU BAR 2W</i>	1	NA	NA	NA	NA
	1059-0443	2X3 TIMER BAR FRONT <i>ASY MENU BAR 3W</i>	NA	1	NA	NA	NA
	1059-0443	2X3 TIMER BAR REAR <i>ASY MENU BAR 3W</i>	NA	1	NA	NA	NA
	1059-0210	2X4 TIMER BAR FRONT <i>ASY MENU BAR 4W</i>	NA	NA	1	NA	NA
	1059-0210	2X4 TIMER BAR REAR <i>ASY MENU BAR 4W</i>	NA	NA	1	NA	NA
	1059-0474	4X2 TIMER BAR FRONT <i>ASY MENU BAR 2W</i>	NA	NA	NA	2	NA
	1059-0474	4X2 TIMER BAR REAR <i>ASY MENU BAR 2W</i>	NA	NA	NA	2	NA
	1059-0209	3X4 TIMER BAR FRONT <i>ASY TOP MENU BAR 4W</i>	NA	NA	NA	NA	1
	1059-0210	3X4 TIMER BAR BOTH <i>ASY BOTTOM MENU BAR 4W</i>	NA	NA	NA	NA	2
	1059-0475	3X4 TIMER BAR REAR <i>ASY TOP REAR MENU BAR 4W</i>	NA	NA	NA	NA	1

*** As Required

HS2-T SPECIFICATIONS

HS2-22-T Specification Sheet

Domestic Base Model	Volts (V)	Amps(A)	Watts(W)	Hz	Cord Type	Shipping Weight
HS2-22-xxxxx	208-240 V	8.7 / 7.5	1800W	60hz	Nema 6-15P	84 lbs / 38 kg

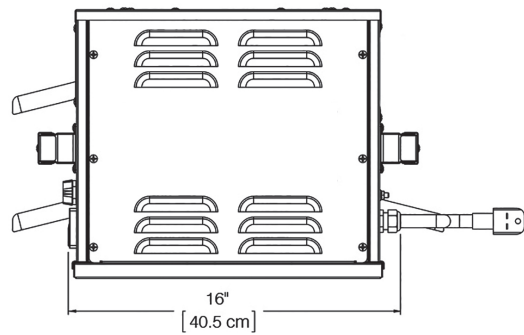
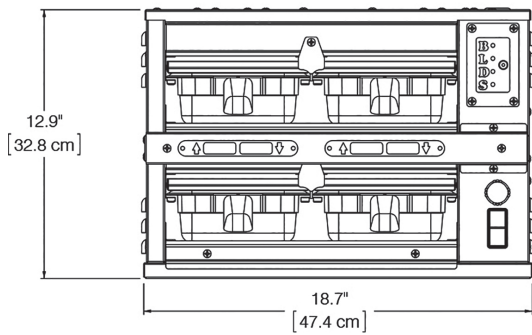
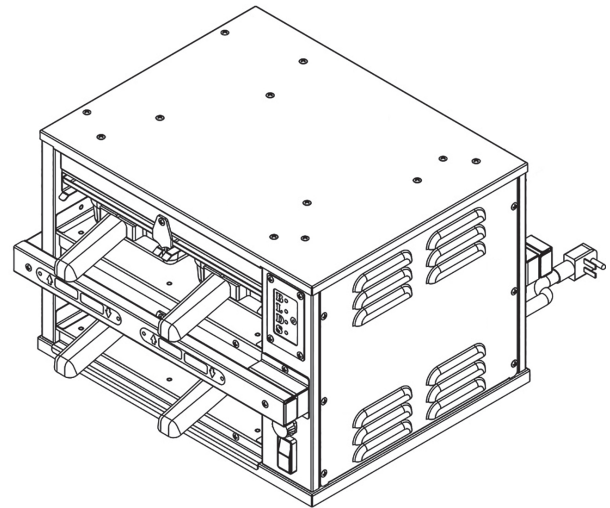
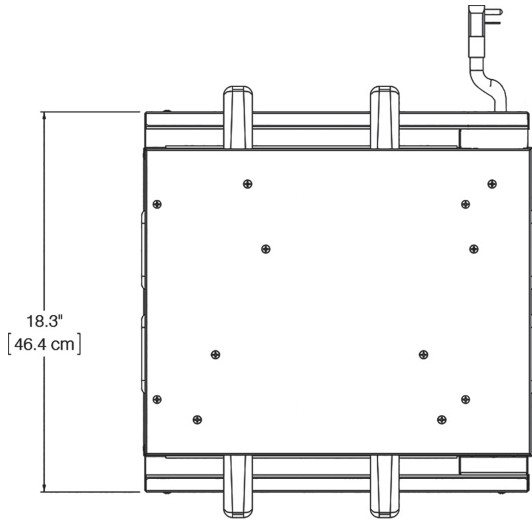

HS2 WIRING SCHEMATICS FOR PANELS AND TIMER BARS

The top portion of the diagram shows the base HS2. The lower part of the diagram represents the timer bar section of the unit.

WIRING DIAGRAM 2x2 HS2

225247 Rev. C 6/1/17

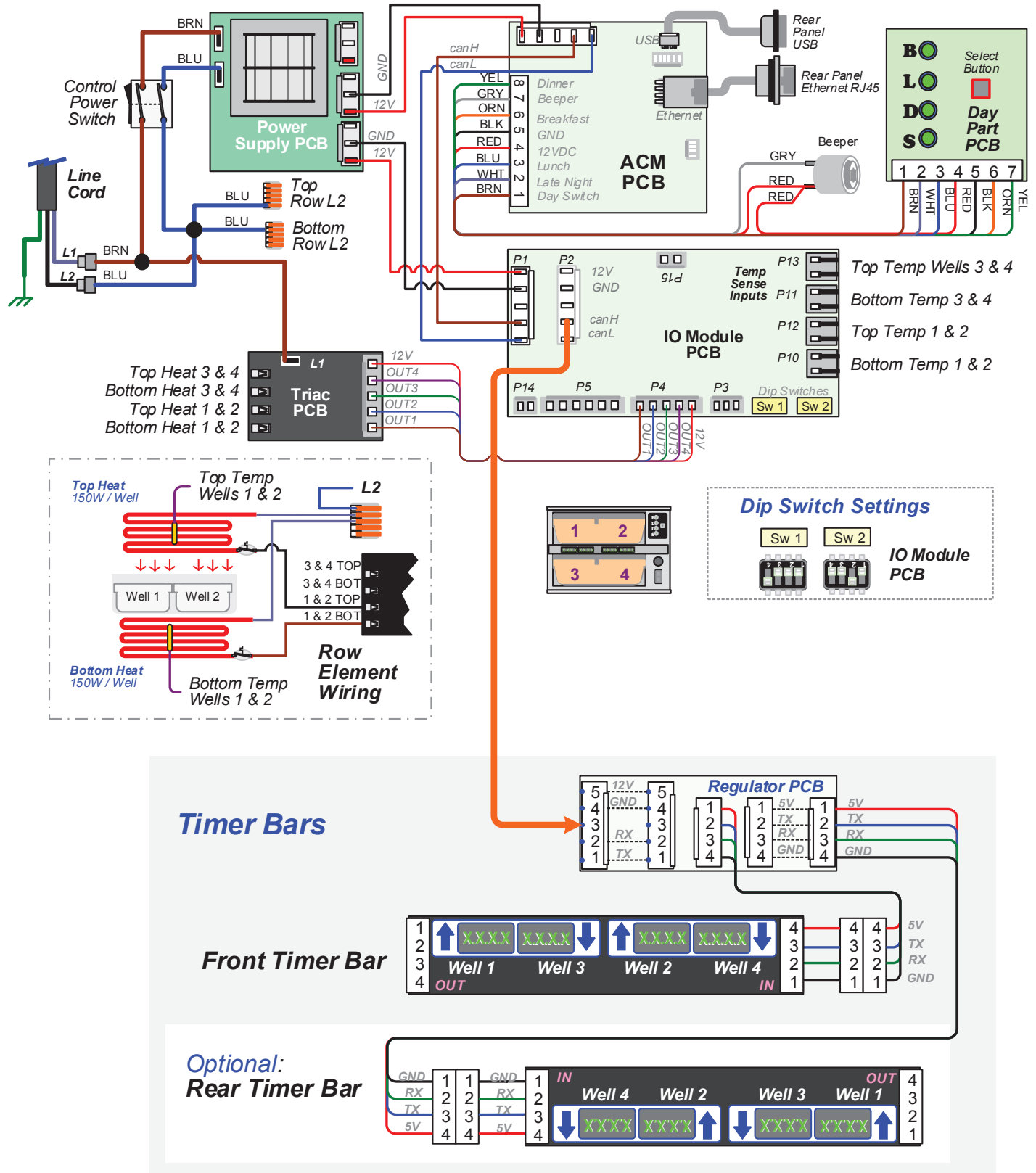

HS2-23-T Specification Sheet

Domestic Base Model	Volts (V)	Amps(A)	Watts(W)	Hz	Cord Type	Shipping Weight
HS2-23-xxxxx	208-240 V	8.7 / 7.5	1800W	60hz	Nema 6-15P	101 lbs / 46 kg

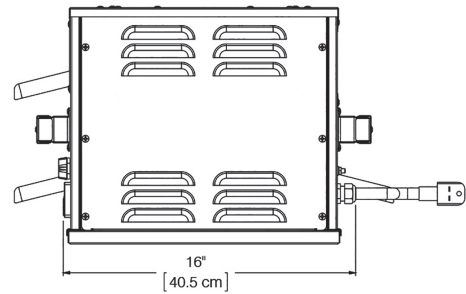
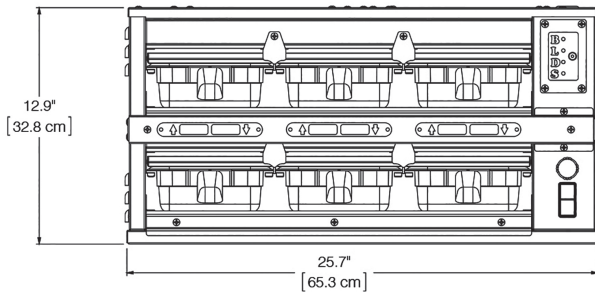
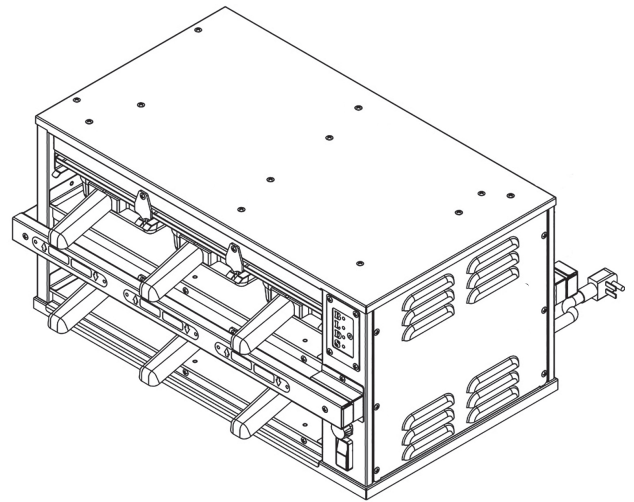
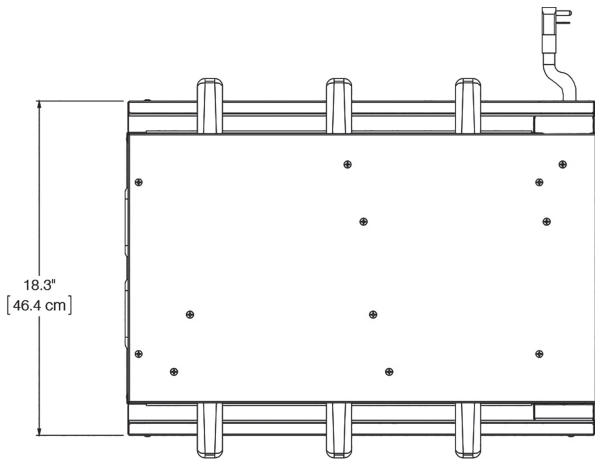

The top portion of the diagram shows the base HS2. The lower part of the diagram represents the timer bar section of the unit.

Wire Diagram - HS2 Zoned 2 x 3

ELC0131 Rev. B (2x3_4z) 6/1/17

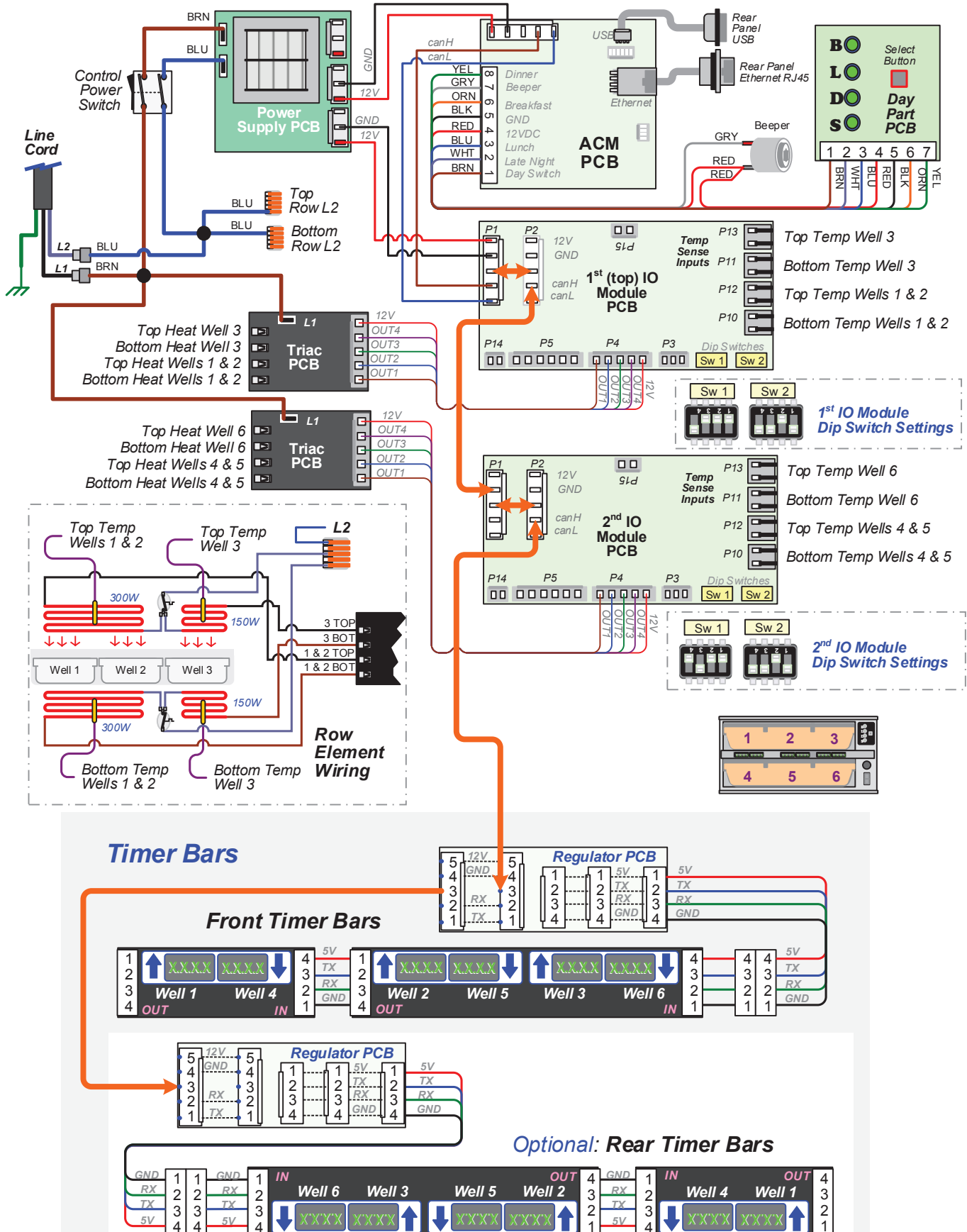

HS2-24-T Specification Sheet

Domestic Base Model	Volts (V)	Amps(A)	Watts(W)	Hz	Cord Type	Shipping Weight
HS2-24-xxxxx	208-240 V	12.0 / 10.0	2400W	60hz	Nema 6-15P	117 lbs / 53 kg

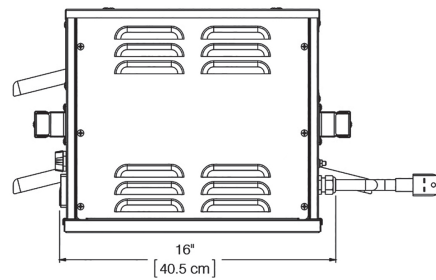
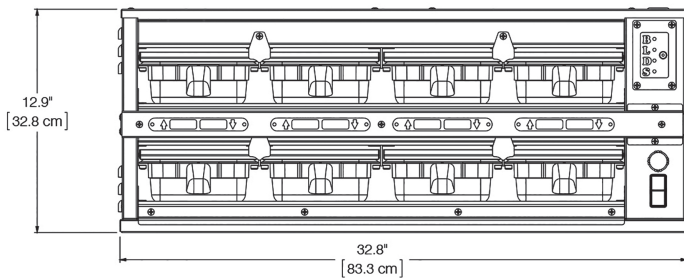
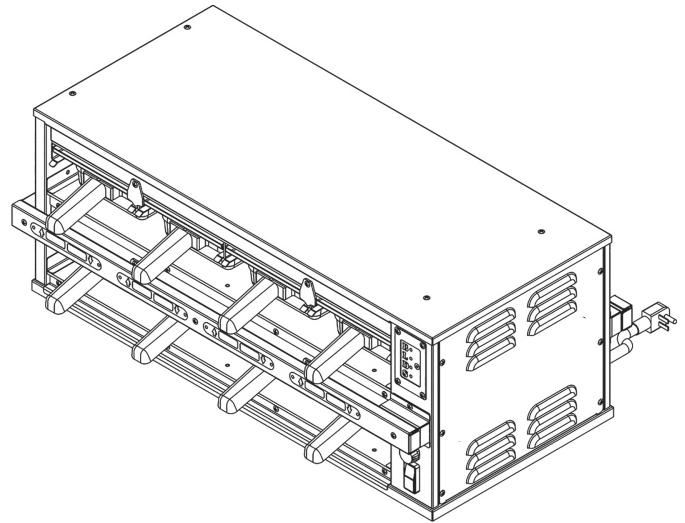
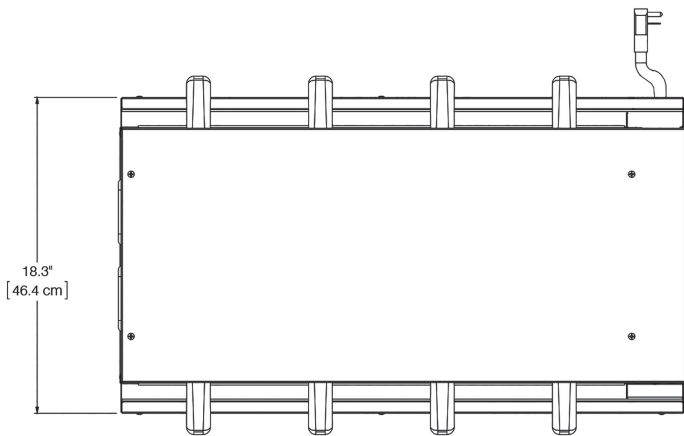

The top portion of the diagram shows the base HS2. The lower part of the diagram represents the timer bar section of the unit.

WIRING DIAGRAM 2x4 HS2
225245 Rev. B 6/1/17

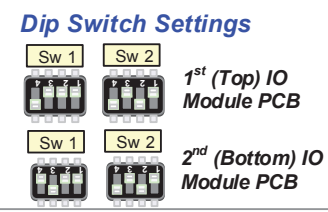
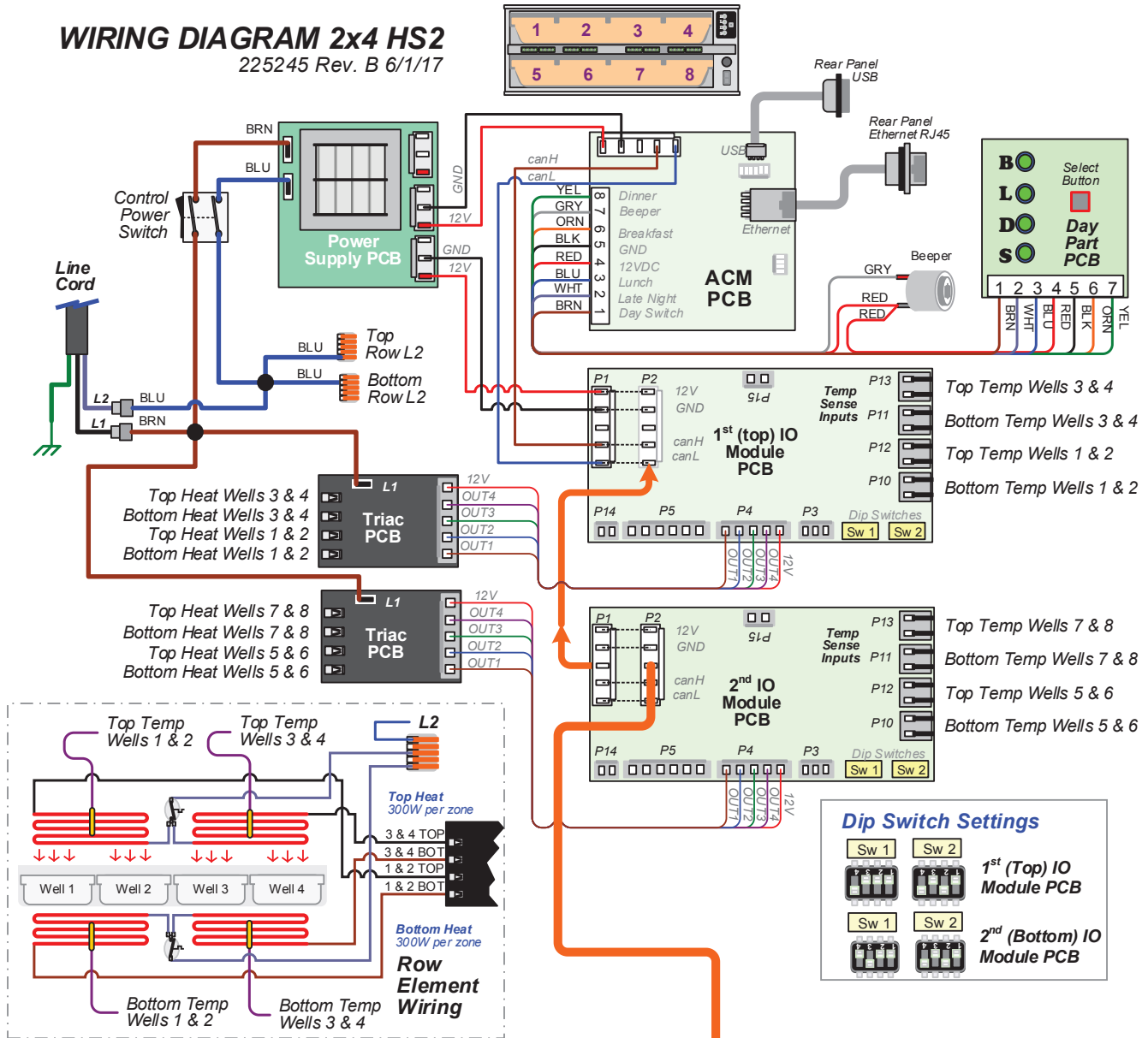

Timer Bars

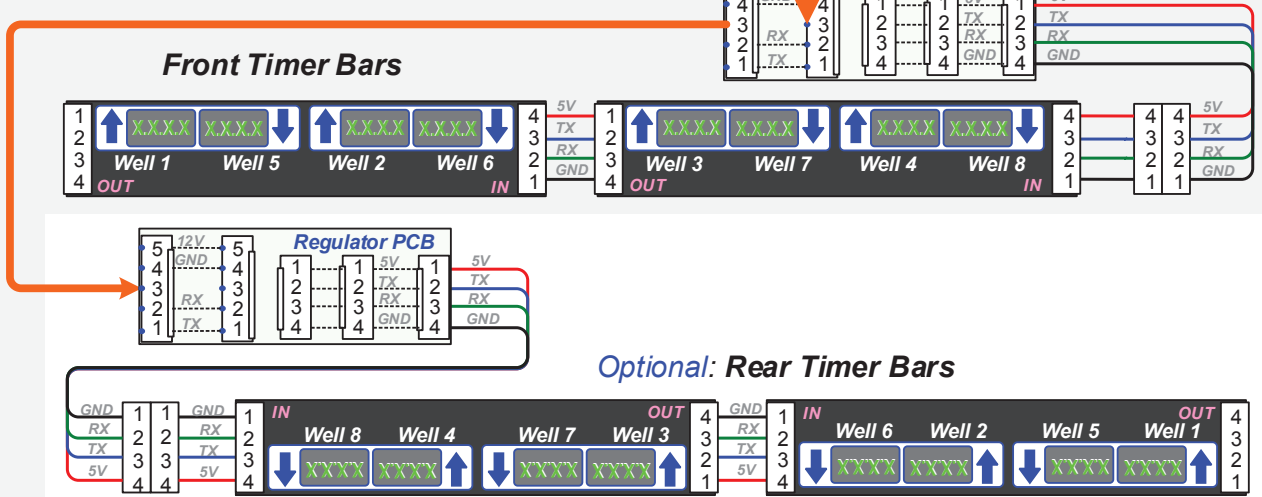

HS2-42-T Specification Sheet

Domestic Base Model	Volts (V)	Amps(A)	Watts(W)	Hz	Cord Type	Shipping Weight
HS2-42-xxxxx	208-240 V	12.0 / 10.0	2400W	60hz	Nema 6-15P	126 lbs / 57 kg

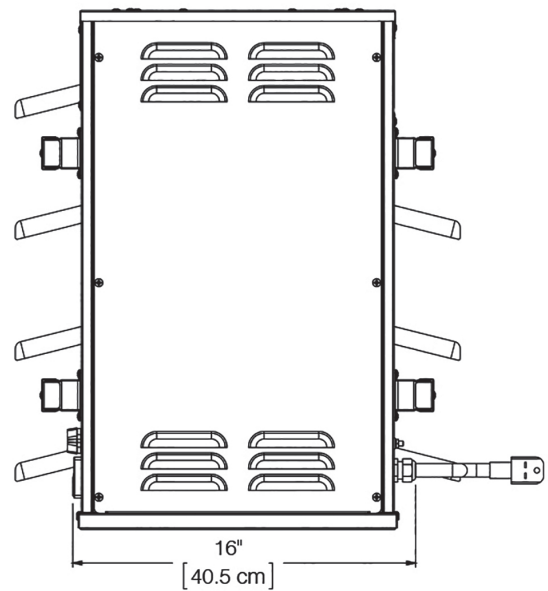
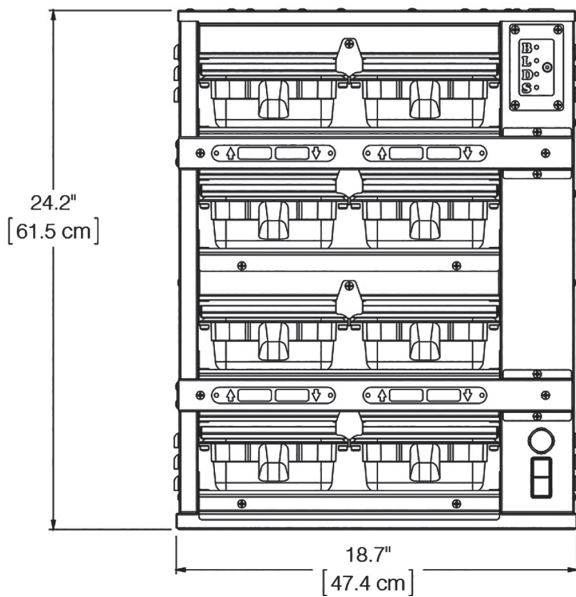
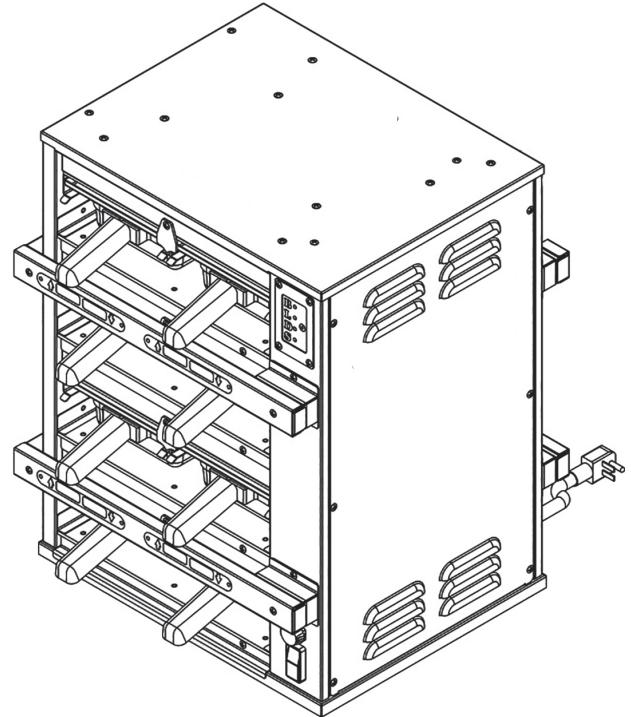
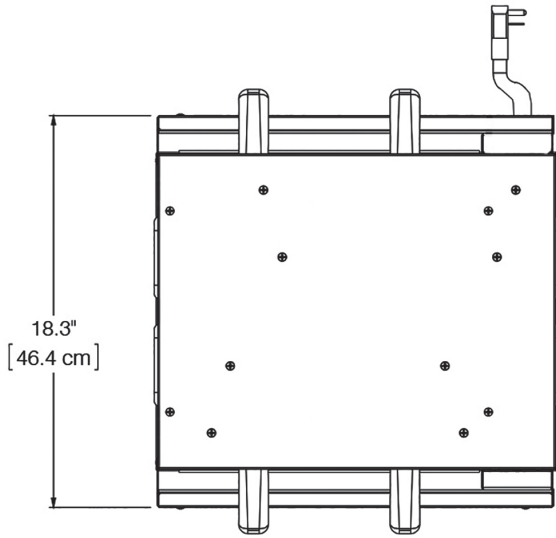

The top portion of the diagram shows the base HS2. The lower part of the diagram represents the timer bar section of the unit.

WIRING DIAGRAM 4x2 HS2 225253 Rev. C 6/1/17

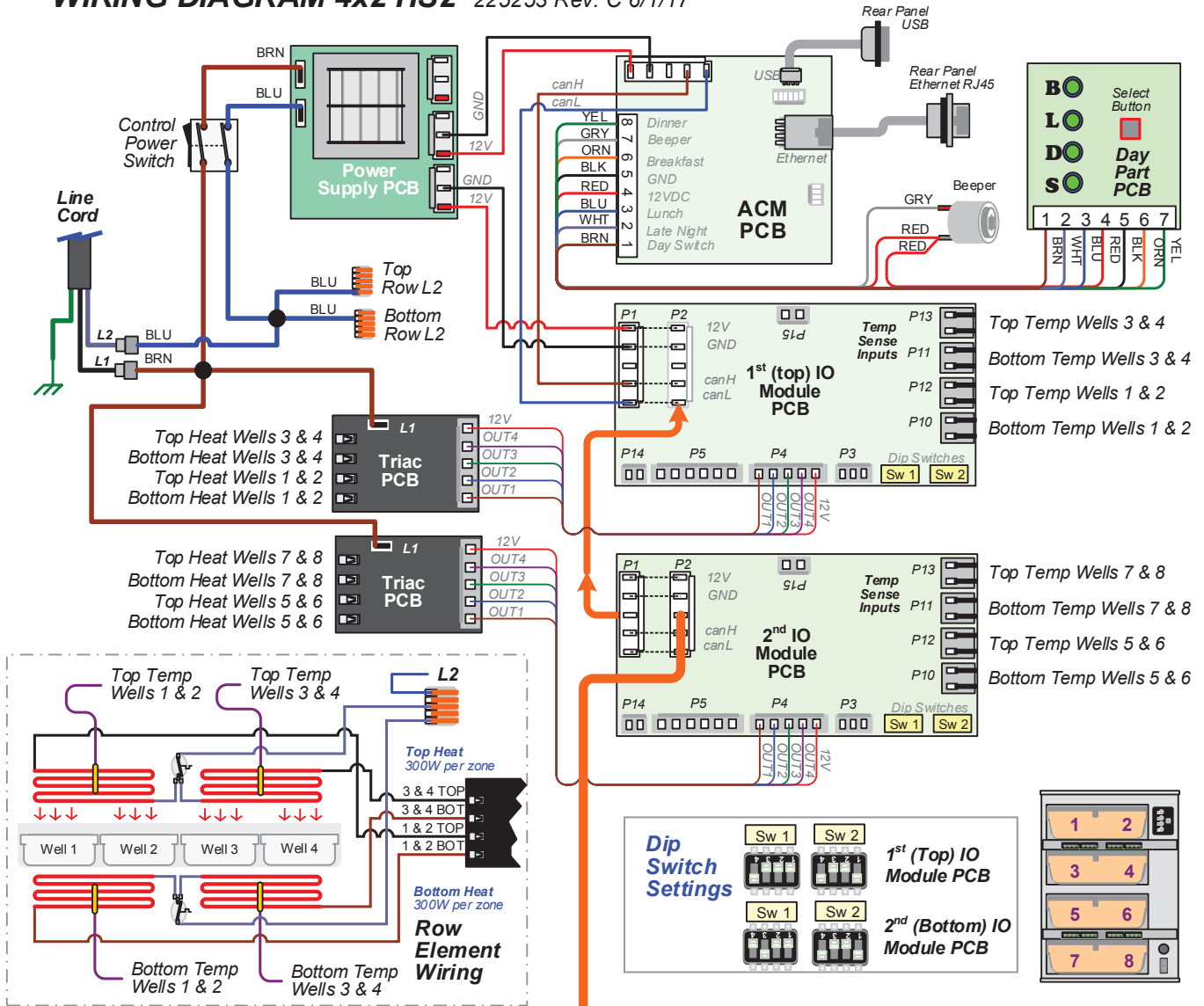

Timer Bars

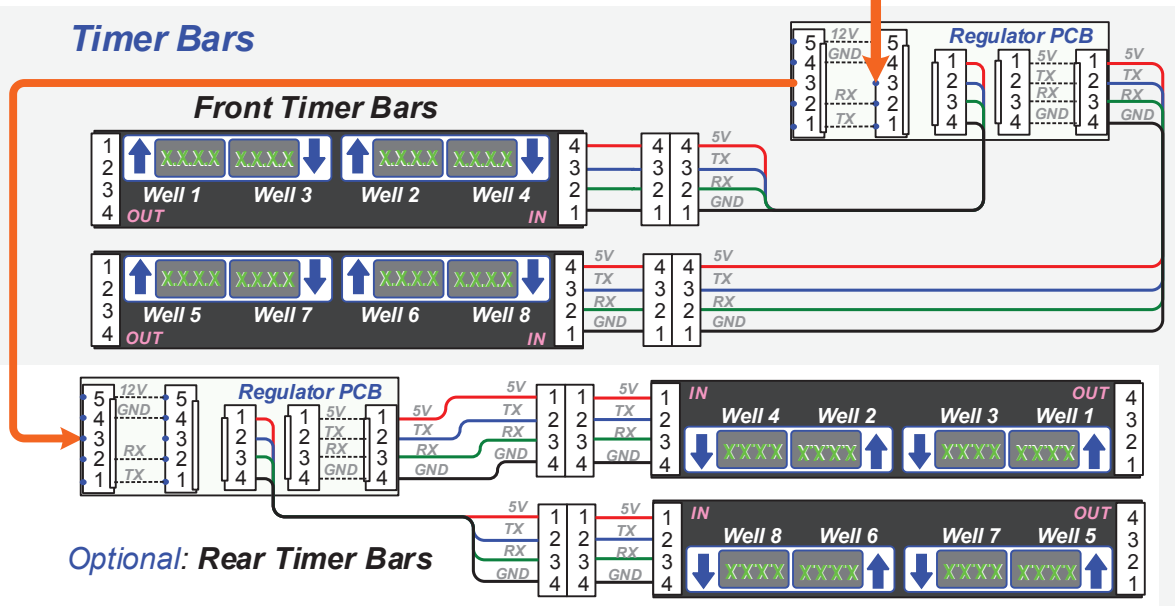

HS2-34-T Specification Sheet

Domestic Base Model	Volts (V)	Amps(A)	Watts(W)	Hz	Cord Type	Shipping Weight
HS2-34-xxxxx	208-240 V	17.3 / 15.0	3600W	60hz	Nema 6-20P	162 lbs / 74 kg

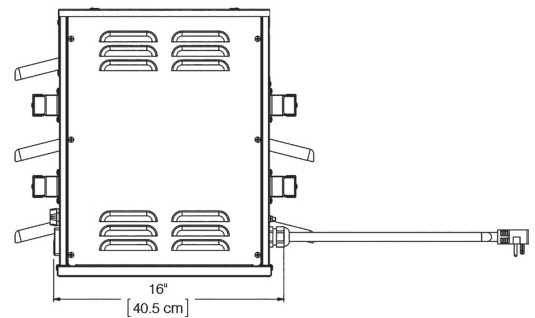
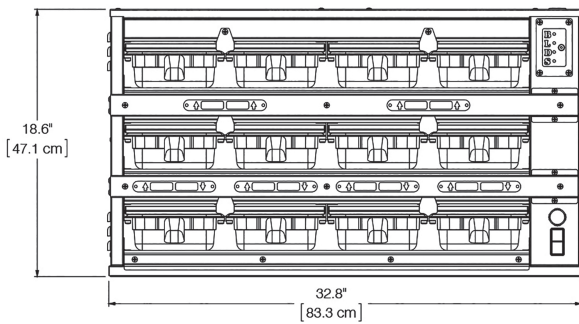
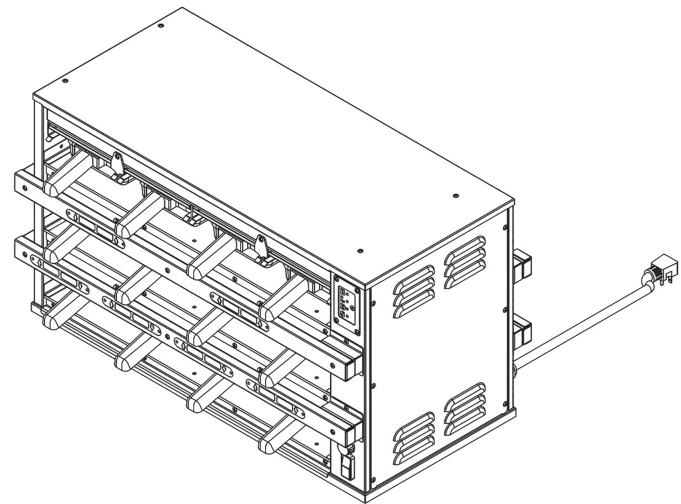
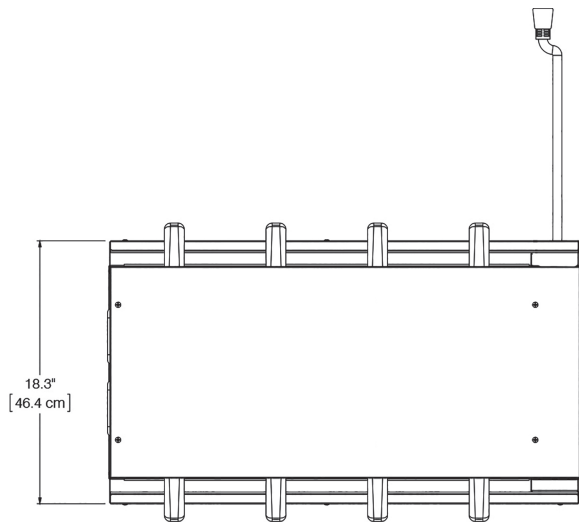

The top portion of the diagram shows the base HS2. The lower part of the diagram represents the timer bar section of the unit.

WIRING DIAGRAM 3x4 HS2

225244 Rev. C 6/1/17

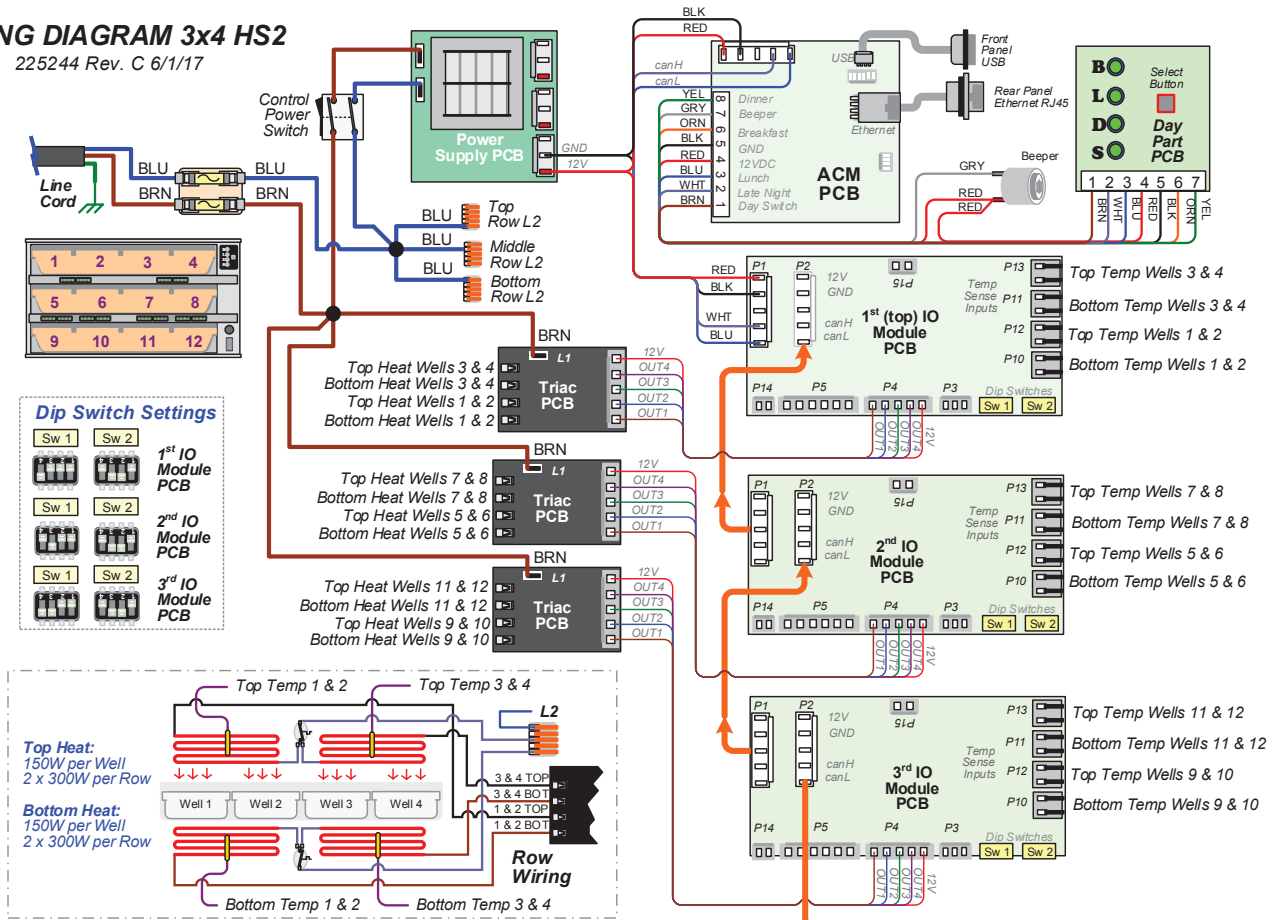

Timer Bars

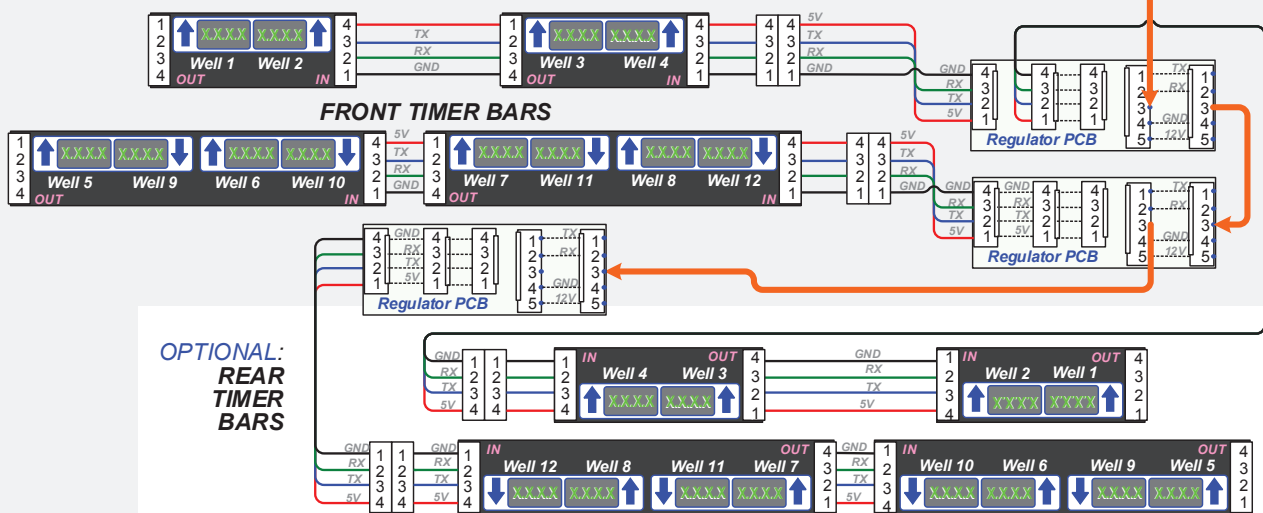



Your Solutions Partner

Duke Manufacturing Co.

2305 N. Broadway

St. Louis, MO 63102

Phone: 314-231-1130

Toll Free: 1-800-735-3853

Fax: 314-231-5074

www.dukemfg.com