

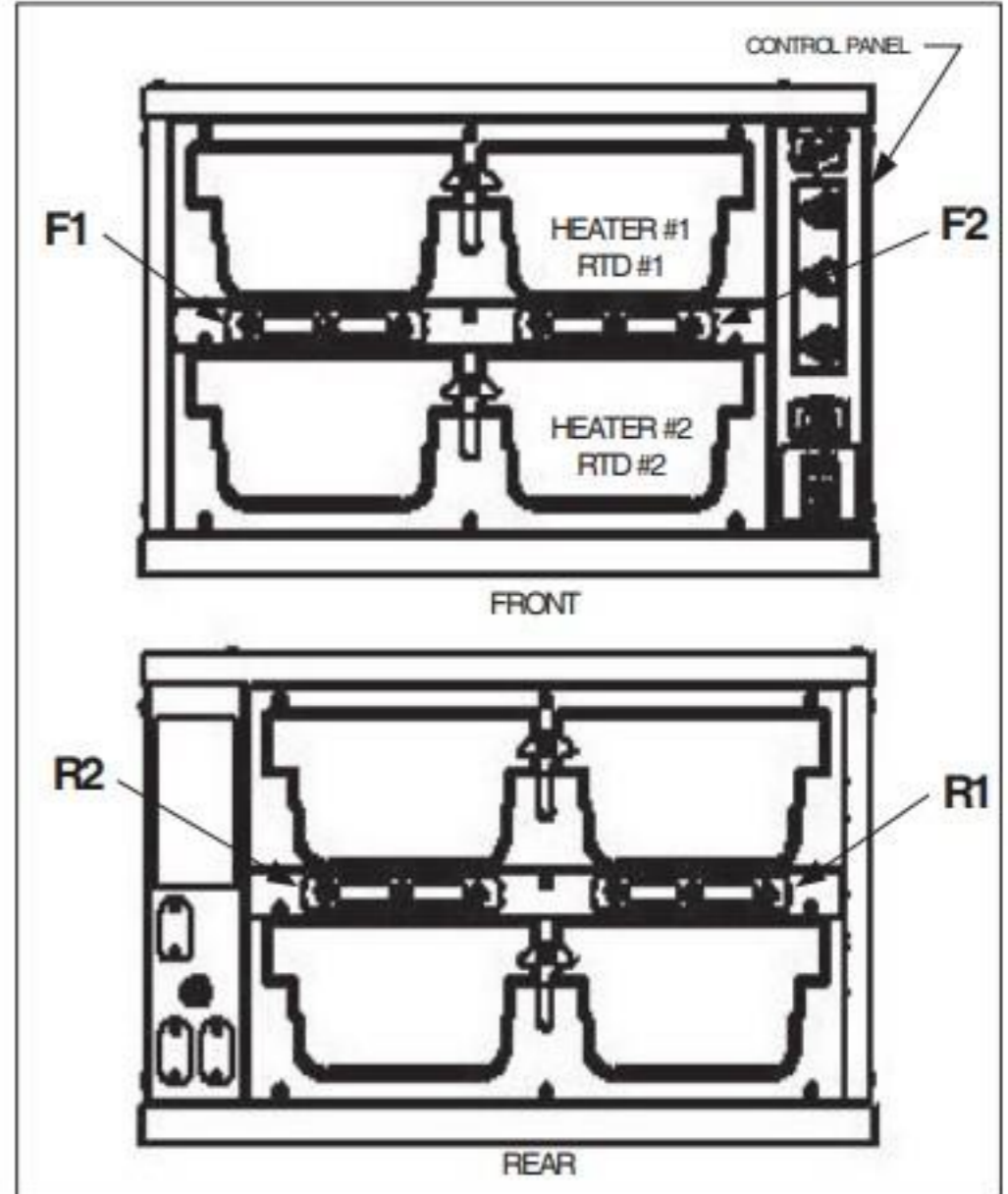

FWM 2-HIGH Internal Wiring Schematic

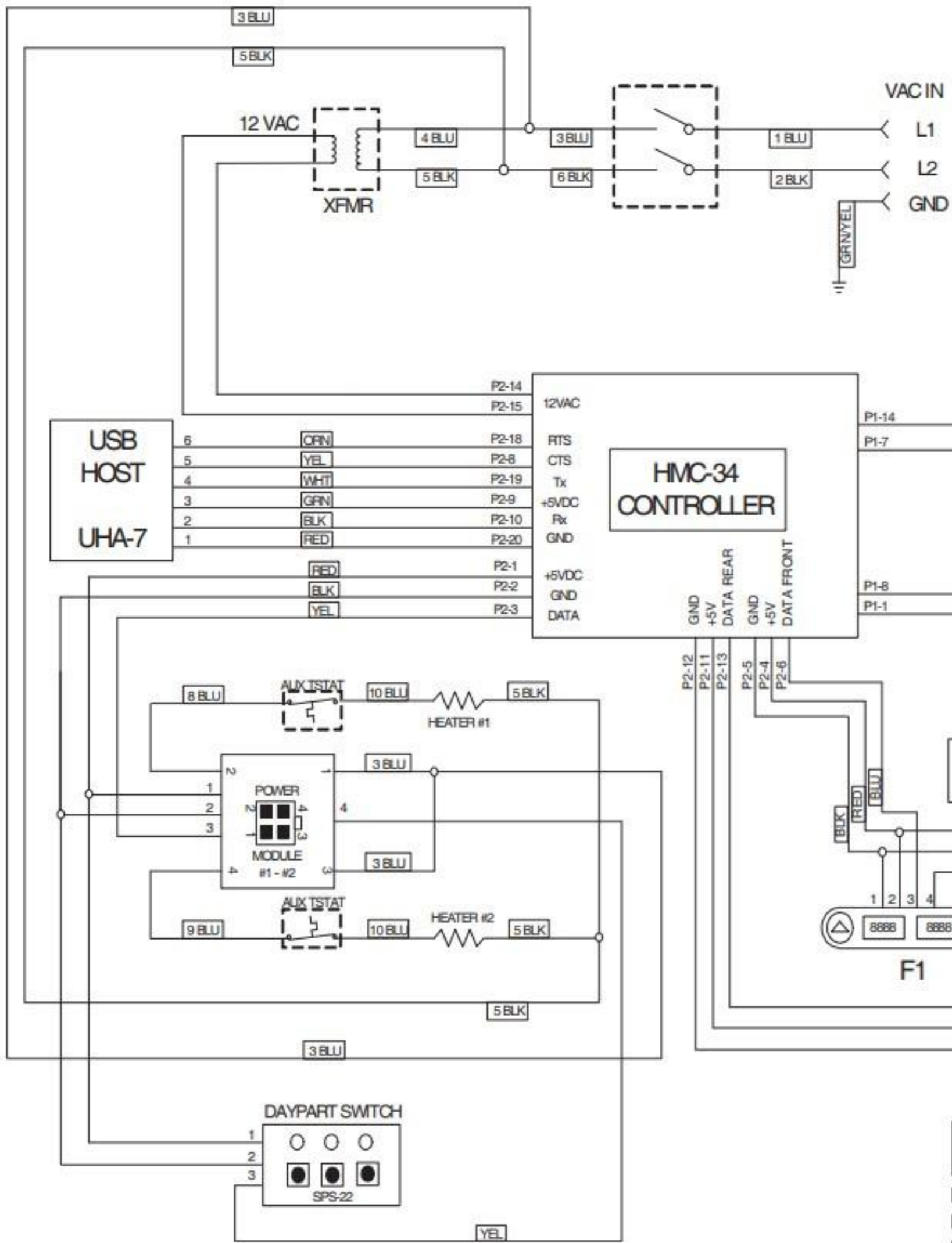

NOTE: F1 IS ALWAYS LEFTMOST KEYPAD WHEN VIEWING FROM FRONT OF UNIT, R1 IS ALWAYS RIGHT MOST WHEN VIEWING FROM REAR

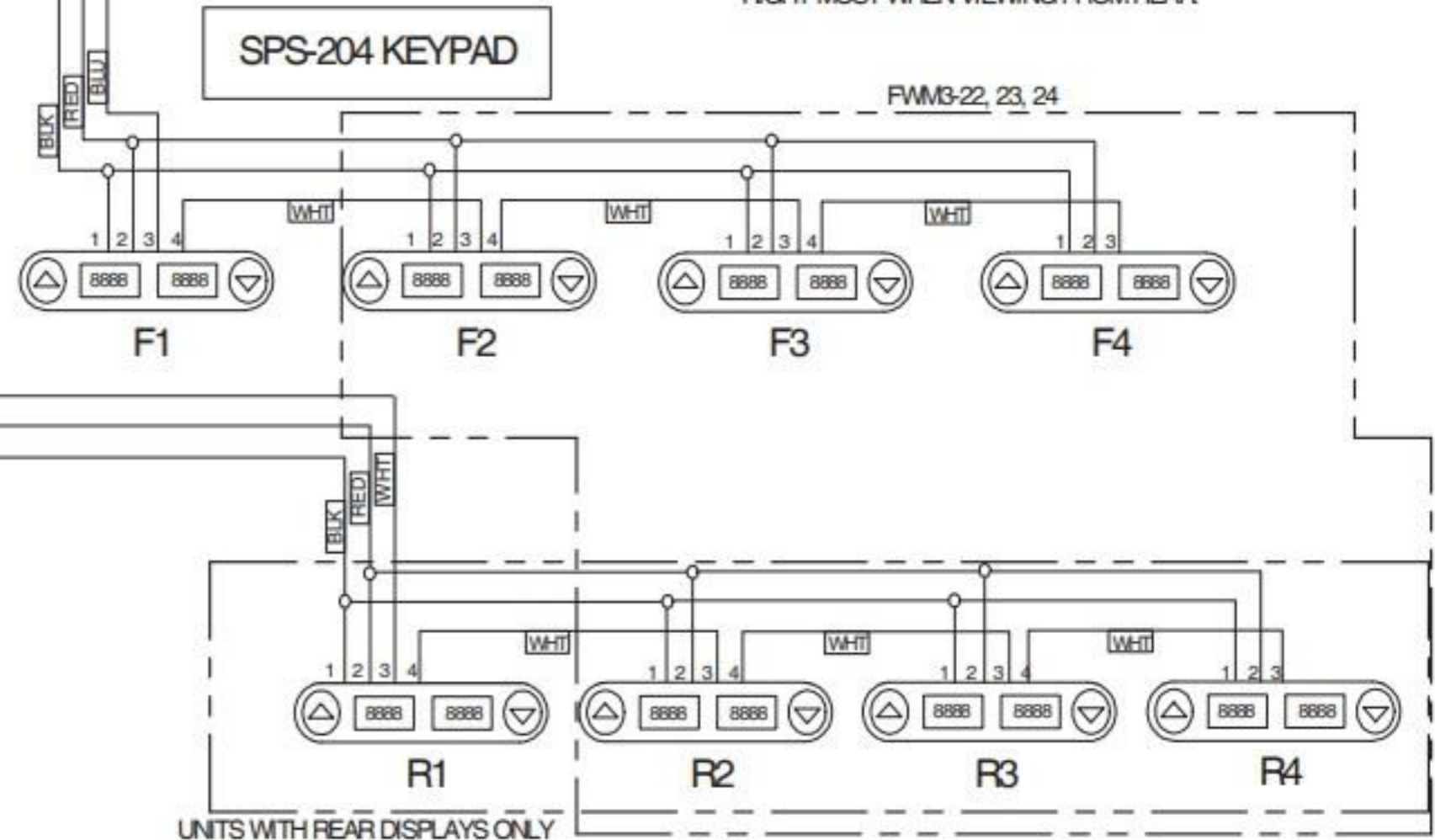

UNITS WITH REAR DISPLAYS ONLY