



Your Solutions Partner

Illustrated Parts List

FRYHOLDING UNIT AIR SCROLL (FHUAS-2)

32/34/36" Wide
Stand Alone Units

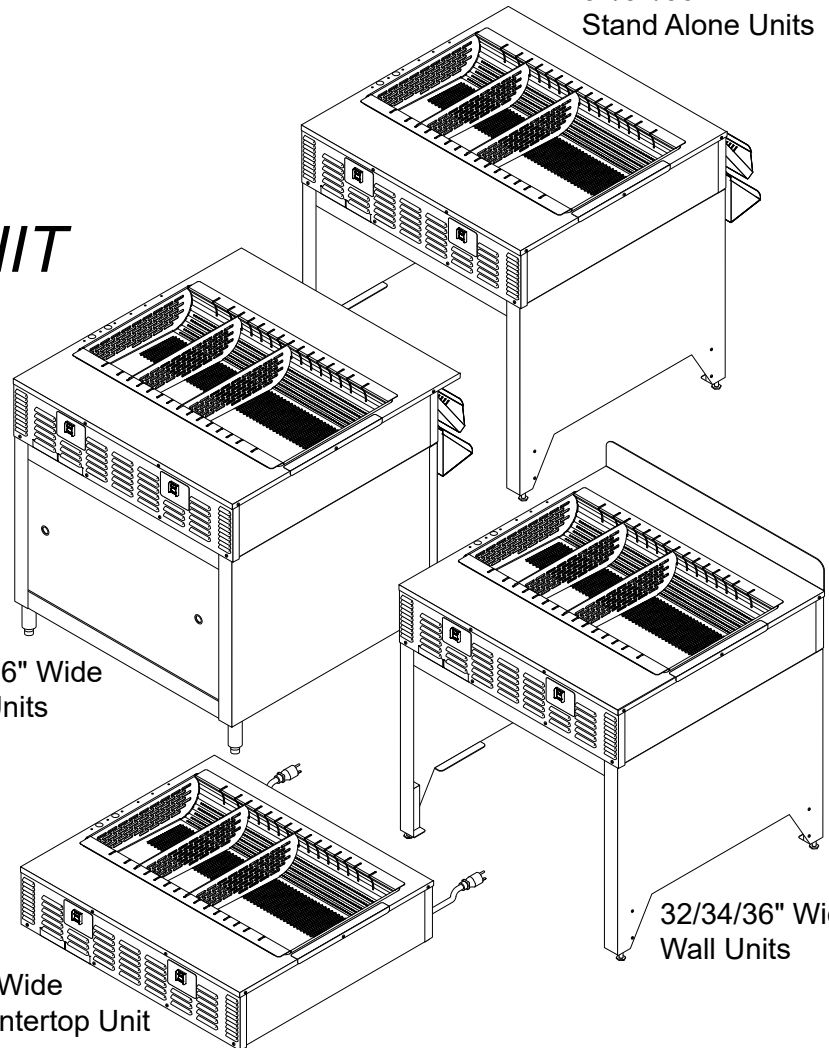

32/34/36" Wide
Inline Units

32/34/36" Wide
Wall Units

36" Wide
Countertop Unit

MODEL

FHUAS-2

Revision "D" Motors Factory Installed In All
Units, Beginning With Serial #02177835

*This manual is Copyright © 2021 Duke Manufacturing Co. All rights reserved.
Reproduction without written permission is prohibited. Duke is a registered
trademark of the Duke Manufacturing Co.*

Duke Manufacturing Co.

2305 N. Broadway • St. Louis, MO 63102

800.735.3853 • 314.231.1130

Fax: 314-231-5074

www.dukemfg.com

TABLE OF CONTENTS

32", 34", & 36" WIDE, FRY HOLDING UNIT AIR SCROLL (FHUAS-2)	3
Figure: PL-1 Fry Holding Unit Air Scroll (FHUAS-2).....	3
Table: PL-1 Fry Holding Unit Air Scroll (FHUAS-2)	4
36" WIDE, MOTOR COOLING RETURN BOX, FHUAS-2	6
Figure: PL-2 36" Motor Cooling Return Box (FHUAS-2).....	6
Table: PL-2 36" Motor Cooling Return Box (FHUAS-2).....	7
32" & 34" WIDE, MOTOR COOLING RETURN BOX, FHUAS-2	8
Figure: PL-3 32" & 34" Motor Cooling Return Box (FHUAS-2)	8
Table: PL-3 32" & 34" Motor Cooling Return Box (FHUAS-2).....	9
WIRE CHASE: 36" WIDE, IN-LINE UNITS, FHUAS-2	10
Figure: PL-4 Wire Chase: 36" Wide, In-Line Units, FHUAS-2.....	10
Table: PL-4 Wire Chase: 36" Wide, In-Line Units, FHUAS-2	10
WIRE CHASE: 36" WIDE, STAND-ALONE & WALL UNITS, FHUAS-2	11
Figure: PL-5 Wire Chase: 36" Wide, Stand-Alone & Wall Units, FHUAS-2.....	11
Table: PL-5 Wire Chase: 36" Wide, Stand-Alone & Wall Units, FHUAS-2	11
TELESCOPING SHELF ASSEMBLY FOR 32", 34" & 36" WIDE, FHUAS-2	12
Figure: PL-6 Telescoping Shelf Assembly for 32", 34" & 36" Wide, FHUAS-2.....	12
Table: PL-6 Telescoping Shelf Assembly for 32", 34" & 36" Wide, FHUAS-2.....	13
FREE STANDING SHELF ASSEMBLY FOR 32", 34" & 36" WIDE, FHUAS-2.....	14
Figure: PL-7 Free Standing Shelf Assembly for 32", 34" & 36" Wide, FHUAS-2	14
Table: PL-7 Free Standing Shelf Assembly for 32", 34" & 36" Wide, FHUAS-2.....	15
ENCLOSED BACK, SHELF ASSEMBLY FOR 32", 34" & 36" WIDE, FHUAS-2	16
Figure: PL-8 Enclosed Back, Shelf Assembly for 32", 34" & 36" Wide, FHUAS-2	16
Table: PL-8 Enclosed Back, Shelf Assembly for 32", 34" & 36" Wide, FHUAS-2.....	17
WIRE DIAGRAM, FHUAS-2.....	18
HOW TO DETERMINE MANUFACTURE DATE FROM DUKE EQUIPMENT SERIAL NUMBERS	19

32", 34", & 36" WIDE, FRY HOLDING UNIT AIR SCROLL (FHUAS-2)

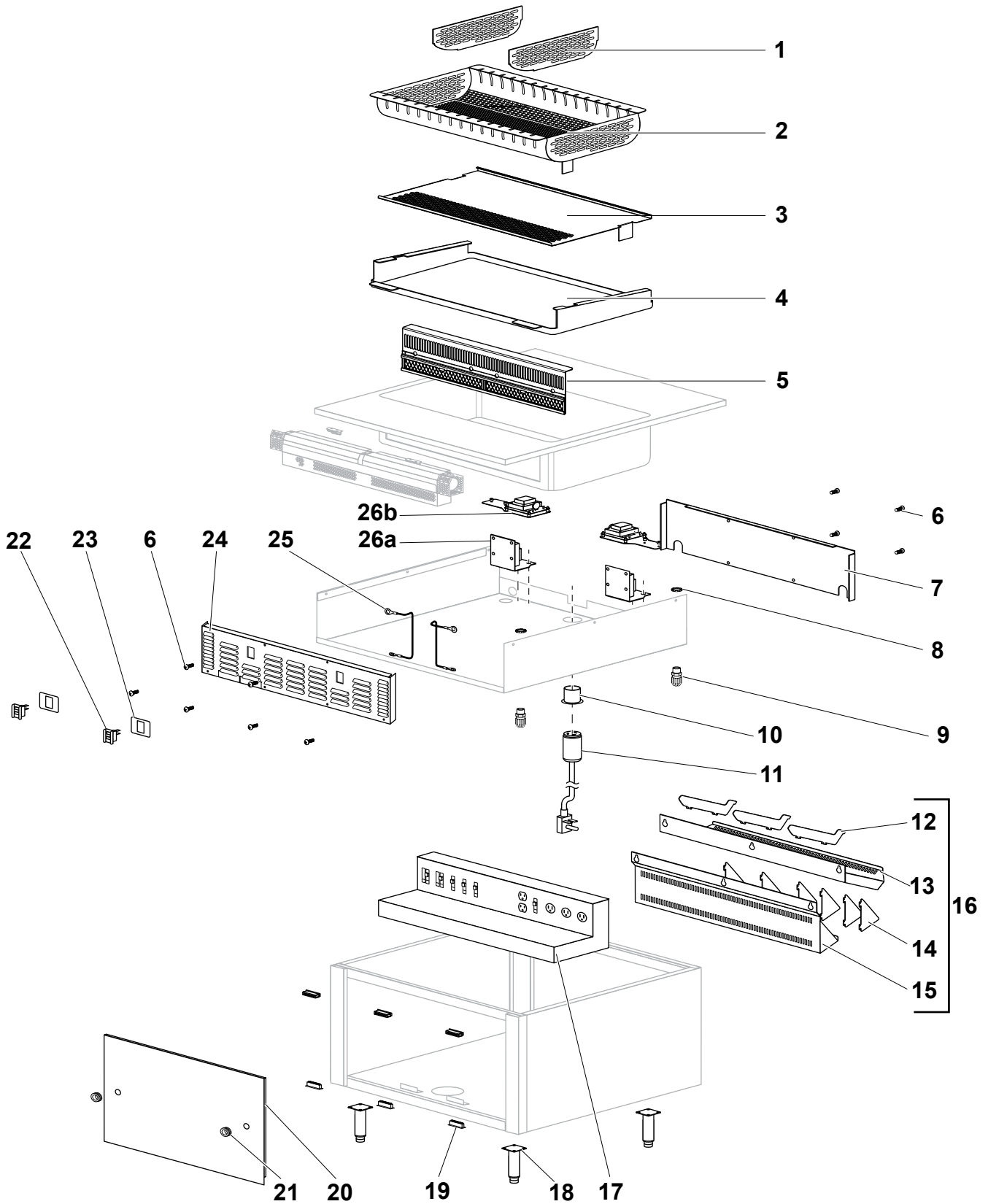

Figure: PL-1 Fry Holding Unit Air Scroll (FHUAS-2)

32", 34", & 36" WIDE, FRY HOLDING UNIT AIR SCROLL (FHUAS-2)

ITEM	PN	DESCRIPTION	QTY
1	413714	DIVIDER, SLOTTED, FHUAS-2	2
2	1033-781	FRY BASKET, 32/34" WIDE FHUAS-2	1
	E050591	FRY BASKET, 36" WIDE FHUAS-2	
3	414071	PLATE, RETURN, 32/34" WIDE FHUAS-2	1
	413721	PLATE, RETURN, 36" WIDE FHUAS-2	
4	414070	COLLECTION PAN, 32/34" WIDE FHUAS-2	1
	413720	COLLECTION PAN, 36" WIDE FHUAS-2	
5	1033-784	FILTER ASSY, 32/34" WIDE FHUAS-2	1
	413715	FILTER ASSY REPLACEMENT, 36" WIDE FHUAS-2	
6	213064	SCREW, 10-24x1/2" TCS RD HD, FHUAS-2	16
7	1033-892	HOUSING BACK, 32" WIDE, INLINE FHUAS-2	1
	1033-893	HOUSING BACK, 34" WIDE, INLINE FHUAS-2	
	E050534	HOUSING BACK, 36" WIDE, INLINE FHUAS-2	
	1033-777	HOUSING BACK, 32" WIDE, STAND ALONE FHUAS-2	
	1033-802	HOUSING BACK, 34" WIDE, STAND ALONE FHUAS-2	
	E050770	HOUSING BACK, 36" WIDE, STAND ALONE FHUAS-2	
	1033-888	HOUSING BACK, 32" WIDE, WALL FHUAS-2	
	1033-889	HOUSING BACK, 34" WIDE, WALL FHUAS-2	
	E050537	HOUSING BACK, 36" WIDE, WALL FHUAS-2	
	E050769	HOUSING BACK, 36" WIDE, COUNTERTOP FHUAS-2	
8	195600	LOCKNUT, CONDUIT, 1/2", FHUAS-2	2
9	115096	CONNECTOR, 1/2" LIQUID TIGHT, FHUAS-2	2
Not Shown	222304	CORD, POWER ASSEMBLY, 20A, 125V, FHUAS-2	2
Not Shown	222170	CORD, POWER ASSEMBLY, 15A 208/240V (36" Wide FHUAS-2 Units, before 1/16/2016)	1
10	222046	RECEPTACLE, FLANGED MALE (Ref-222059), FHUAS-2	1
11	222059	POWER CORD, 15A 250V W/TERMINALS (Ref-222046), FHUAS-2	1
12	412993	DIVIDER FRY STATION SHELF, FHUAS-2	3
13	1033-850	SHELF FRY CARTON, 32" WIDE, INLINE & STAND ALONE FHUAS-2	1
	1033-853	SHELF FRY CARTON, 34" WIDE, INLINE & STAND ALONE FHUAS-2	
	413011	SHELF FRY CARTON, 36" WIDE, INLINE & STAND ALONE FHUAS-2	
14	E050217	DIVIDER, CONDIMENT STORAGE, FHUAS-2	6
15	1033-851	SHELF CONDIMENT STORAGE, 32" WIDE, INLINE & STAND ALONE FHUAS-2	1
	1033-854	SHELF CONDIMENT STORAGE, 34" WIDE, INLINE & STAND ALONE FHUAS-2	
	E050216	SHELF, CONDIMENT STORAGE, 36" WIDE, INLINE & STAND ALONE FHUAS-2	
16	1033-849	ASY COND. & BAG SHELVES, 32" WIDE, INLINE & STAND ALONE FHUAS-2	1
	1033-852	ASY COND. & BAG SHELVES, 34" WIDE, INLINE & STAND ALONE FHUAS-2	
	E050495	ASY, COND. & BAG SHELVES, 36" WIDE, INLINE & STAND ALONE FHUAS-2	
17	E050527	ASSY, WIRE CHASE, IN-LINE, SCROLL FHU, S.S.	1
	E050490	ASSY, WIRE CHASE, STAND ALONE & STAND ALONE WALL	
18	214508	LEG, SS 1-5/8" x 6" ADJUSTABLE, INLINE FHUAS-2	4
19	57100	CATCH, MAGNETIC, INLINE FHUAS-2	6

Table: PL-1 Fry Holding Unit Air Scroll (FHUAS-2)

32", 34", & 36" WIDE, FRY HOLDING UNIT AIR SCROLL (FHUAS-2)

20	1033-876	REMOVABLE PANEL, 32" WIDE INLINE FHUAS-2	1
	1033-883	REMOVABLE PANEL, 34" WIDE INLINE FHUAS-2	
	E050492	REMOVABLE PANEL, 36" WIDE INLINE FHUAS-2	
21	228504	RING, FINISHING NP 1", INLINE FHUAS-2	2
22	222010	SWITCH, 125V DPST MAINTAINED, FHUAS-2	2
23	225436	MYLAR, FHUAS-2	2
24	1033-820	HOUSING, FRONT, 32" WIDE FHUAS-2	1
	1033-824	HOUSING, FRONT, 34" WIDE FHUAS-2	
	E050799	HOUSING, FRONT, 36" WIDE FHUAS-2	
	1033-969	Housing, Front Lift Off Panel	1
	1033-971	Housing, Front Lift Off Panel	
	1033-960	Housing, Front Lift Off Panel	
25	115350	LANYARD, 8 INCH LONG, FHUAS-2	2
26a	1033-928	ASSEMBLY BOARD, VOLTAGE REDUCER, FHUAS-2	2
26b	1033-929	ASSEMBLY BOARD, VOLTAGE REDUCER, FLAT (36" Wide Counter Top Version Only)	
Not Shown	222724	RELAY, TE T92, 120V COIL, DPST N.O. CONTACTS	1
Not Shown	223529	TERMINAL BLOCK, 4 CIRCUIT, FHUAS-2	2
Not Shown	E050817	COVER PLATE, SHELF HOLES, FHUAS-2	1
Not Shown	229401	INSTRUCTIONS, FRY HOLDING UNIT, DAILY CLEANING	1
Not Shown	600555	Kit, 32" FHUAS, Front Panel and Duct Seal	1
Not Shown	600556	Kit, 34" FHUAS, Front Panel and Duct Seal	1
Not Shown	600552	Kit, 36" FHUAS, Front Panel and Duct Seal	1

36" WIDE, MOTOR COOLING RETURN BOX, FHUAS-2

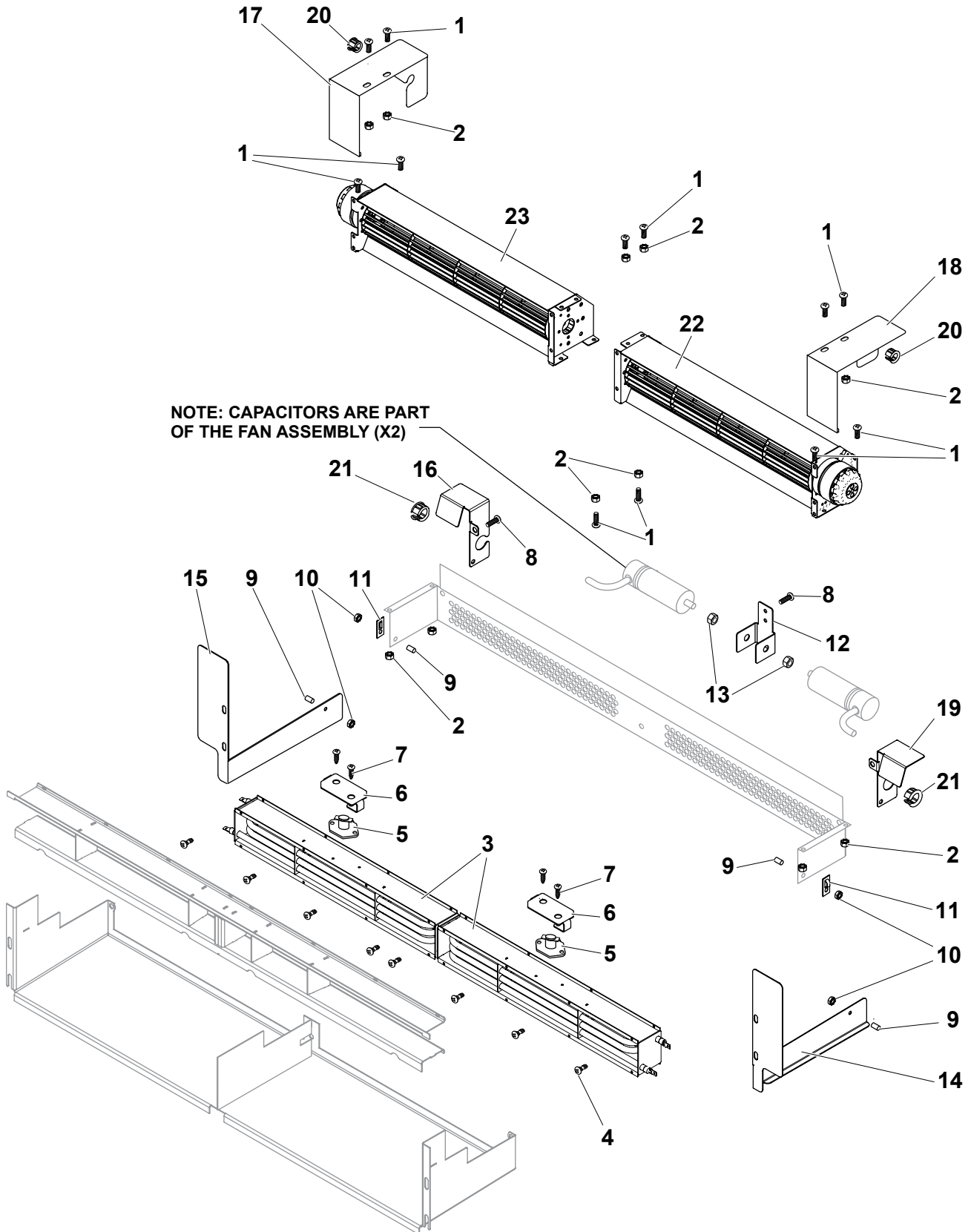
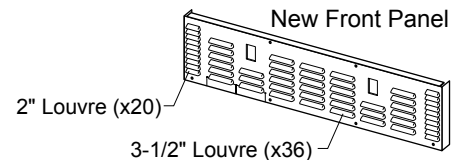
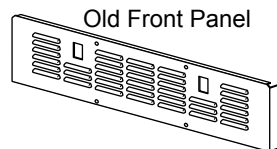

Figure: PL-2 36" Motor Cooling Return Box (FHUAS-2)

36" WIDE, MOTOR COOLING RETURN BOX, FHUAS-2

ITEM	PN	DESCRIPTION	QTY
1	213359	SCREW, 8-32x1/2 THRUSS PHILLI S/S	12
2	223309	NUT, KEEPS #8-32 SS	12
3	225445	HEATER,CALROD 120V 1850W	2
4	223353	SCREW, 8-32X 3/8 PPHTCS F W/THREAD LOCK	8
5	155753	THERMOSTAT, HI LIMIT	2
6	1033-520	GUARD, HIGH LIMIT, FHU	2
7	213032	SCREW,8-18x1/2" TEK PHIL	4
8	213064	SCREW,10-24x1/2" TCS RD H	3
9	167209	STUD,PEM 10-24 X 1/2 S/S FHS-024-8	4
10	213322	NUT KEPS 10-24	4
11	156912	BASE,CABLE MTG TIE	2
12	1033-629	BRACKET, CAPACITOR	1
13	223106	NUT, M8 18-8 SS HEX 1.25 PITCH 13MM W-6.5MM H	2
14	E050794	PANEL, LEFT, BACK, FHUAS, MOTOR COOL	1
15	E050793	PANEL, RIGHT, BACK, FHUAS, MOTOR COOL	1
16	E050795	PANEL, FRONT, RIGHT, FHUAS, MOTOR COOL	1
17	E050796	PANEL, TOP, RIGHT, FHUAS, MOTOR COOL	1
18	E050798	PANEL, TOP, LEFT, FHUAS, MOTOR COOL	1
19	E050797	PANEL, FRONT, LEFT, FHAUS, MOTOR COOL	1
20	175512	BUSHING,HEYCO # 2871 OPEN/CLOSE	2
21	514795	BUSHING, .875 O/C HEYCO 2874	2
22	225443D	FAN MOTOR, LH (Rev-D), 36" Wide FHUAS-2	1
23	225442D	FAN MOTOR, RH (Rev-D), 36" Wide FHUAS-2	1
Not Shown	414268	RETRO-KIT, LH & RH FAN MOTORS (Rev-D), 36" WIDE FHUAS-2	1
Not Shown	414271	RETRO-KIT, LH & RH FAN MOTORS (Rev-D), RELAYS, FRONT PANEL WITH SWITCHES & DUCT WORK, 36" WIDE FHUAS-2	1

The above KIT ([414271](#)) may be required for an older version of the FHUAS-2. The **Front Panel** ([E050799](#)) has been updated and now has additional 2" louvres along both sides of the front panel. If the front panel on unit does not have these additional 2" louvres, kit number [414271](#) should be installed.



All fan motor replacements for 36" wide FHUAS-2 units, should Use the current "Rev-D" Fan Motors. Rev-D Fan Motors are labeled with the Manufacture's part number listed below.

1073269 - Left Hand Fan Motor

1073270 - Right Hand Fan Motor

Table: PL-2 36" Motor Cooling Return Box (FHUAS-2)

32" & 34" WIDE, MOTOR COOLING RETURN BOX, FHUAS-2

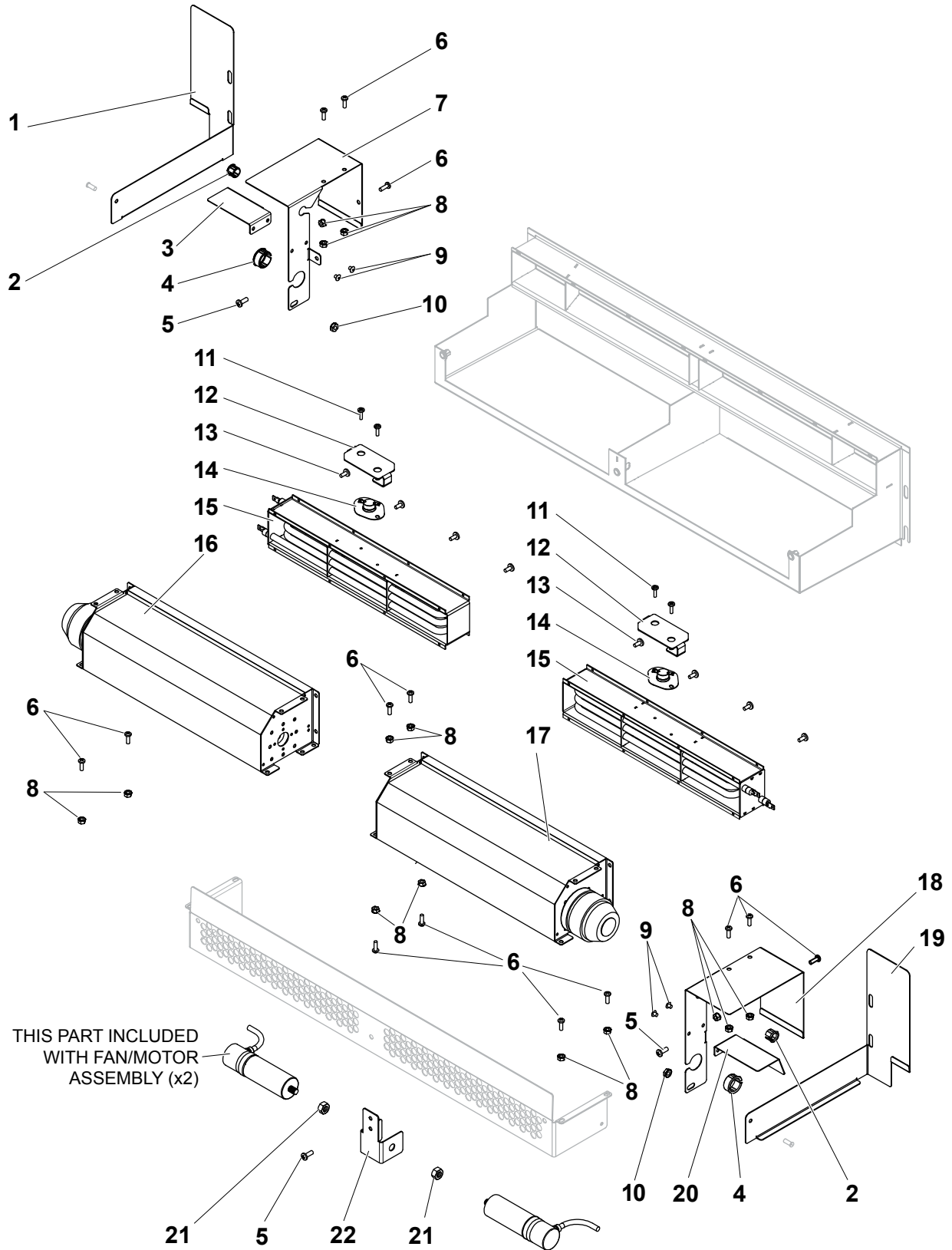

Figure: PL-3 32" & 34" Motor Cooling Return Box (FHUAS-2)

32" & 34" WIDE, MOTOR COOLING RETURN BOX, FHUAS-2

ITEM	PN	DESCRIPTION	QTY
1	1033-812	REAR COOLING PANEL, LEFT, 32" WIDE FHUAS-2	1
	1033-827	REAR COOLING PANEL, LEFT, 34" WIDE FHUAS-2	
2	175512	BUSHING, HEYCO # 2871 OPEN/CLOSE	2
3	1033-816	COOLING DUCT, LEFT, 32" WIDE FHUAS-2	1
	1033-831	COOLING DUCT, LEFT, 34" WIDE, FHUAS-2	
4	514795	BUSHING, .875 O/C HEYCO 2874	2
5	213064	SCREW, 10-24X1/2" TCS RD H	3
6	213359	SCREW, 8-32 X 1/2" THRUSS PHILLIPS S/S	14
7	1033-814	COOLING HOOD, LEFT, 32" WIDE FHUAS-2	1
	1033-829	COOLING HOOD, LEFT, 34" WIDE FHUAS-2	
8	223309	NUT, KEEPS #8-32 SS	1
9	213166	RIVET, SS DOME HD SS-52	4
10	213322	NUT KEPS 10-24	2
11	213032	SCREW, 8-18X1/2" TEK PHIL	4
12	1033-520	GUARD, HIGH LIMIT	2
13	223353	SCREW, 8-32X 3/8 PPHTCS F W/THREAD LOCK	8
14	155753	THERMOSTAT, HI LIMIT	2
15	225449	32" & 34" HEATER, 120V, 1850W	2
16	225445D	FAN MOTOR, LH (Rev-D), 32" and 34" WIDE FHUAS-2	1
17	225444D	FAN MOTOR, RH (Rev-D), 32" and 34" WIDE FHUAS-2	1
Not Shown	414269	RETRO-KIT, LH & RH FAN MOTORS (Rev-D), 34" WIDE FHUAS-2	1
Not Shown	414270	RETRO-KIT, LH & RH FAN MOTORS (Rev-D), 32" WIDE FHUAS-2	1
18	1033-813	COOLING HOOD, RIGHT, 32" WIDE FHUAS-2	1
	1033-828	COOLING HOOD, RIGHT, 34" WIDE FHUAS-2	
19	1033-811	REAR COOLING PANEL, RIGHT, 32" WIDE FHUAS-2	1
	1033-826	REAR COOLING PANEL, RIGHT, 34" WIDE FHUAS-2	
20	1033-815	COOLING DUCT, RIGHT, 32" WIDE FHUAS-2	1
	1033-830	COOLING DUCT, RIGHT, 34" WIDE FHUAS-2	
21	223106	NUT, M8 18-8 SS HEX 1.25 PITCH 13MM W-6.5MM H	2
22	1033-629	BRACKET, CAPACITOR	1

All Fan Motor replacements for 32" & 34" wide FHUAS-2 units, should use the current "Rev-D" Fan Motors. Rev-D Fan Motors are labeled with the Manufacture's part number listed below.

1073267 - Left Hand Fan Motor

1073268 - Right Hand Fan Motor

Table: PL-3 32" & 34" Motor Cooling Return Box (FHUAS-2)

WIRE CHASE: 36" WIDE, IN-LINE UNITS, FHUAS-2

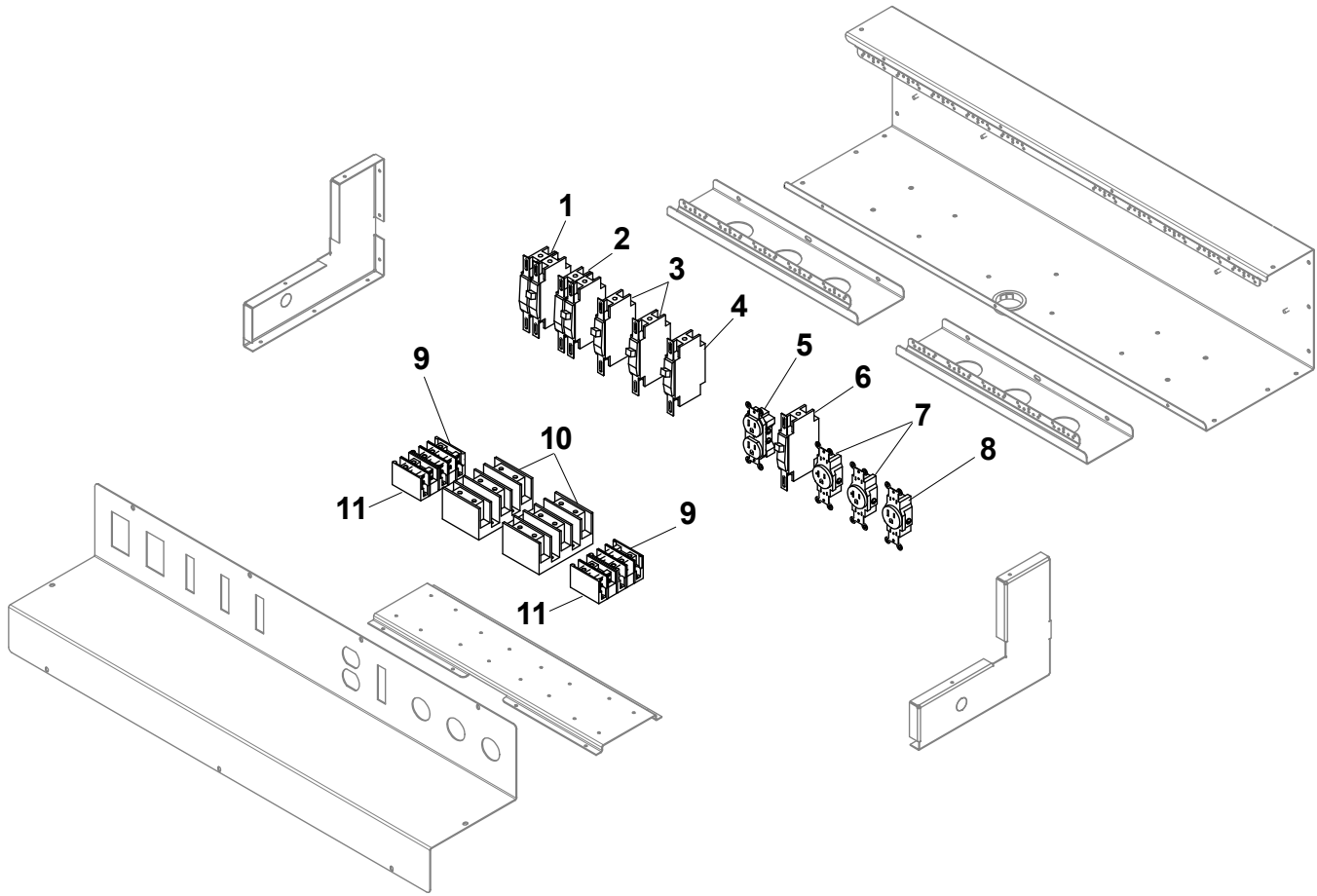

Figure: PL-4 Wire Chase: 36" Wide, In-Line Units, FHUAS-2

ITEM	PN	DESCRIPTION	QTY
1	222602	BREAKER, 15A DBL POLE #QOU215	1
2	212998	BREAKER, SQD 2P 20A QOU220	1
3	212997	BREAKER,SINGLE 1P 20A QOU120	2
4	212996	BREAKER, SINGLE 1P 15A QOU115	1
5	222177	RECEPTACLE, NEMA 5-15R BROWN 5252AB	1
6	212995	BREAKER, SINGLE 1P 10A QOU110	1
7	212337	RECEPTACLE, 5-20 SINGLE GRAY, 20A, 125V	2
8	212177	RECPT, ELEC 5-15 SINGLE HBL5261	1
9	212994	BLOCK, TERMINAL 3 POLE 9080LBA361104	2
10	222018	BLOCK, TERMINAL 3 CONN.	2
11	212993	BLOCK, TERMINAL 2 POLE 9080LBA261104	2

Table: PL-4 Wire Chase: 36" Wide, In-Line Units, FHUAS-2

WIRE CHASE: 36" WIDE, STAND-ALONE & WALL UNITS, FHUAS-2

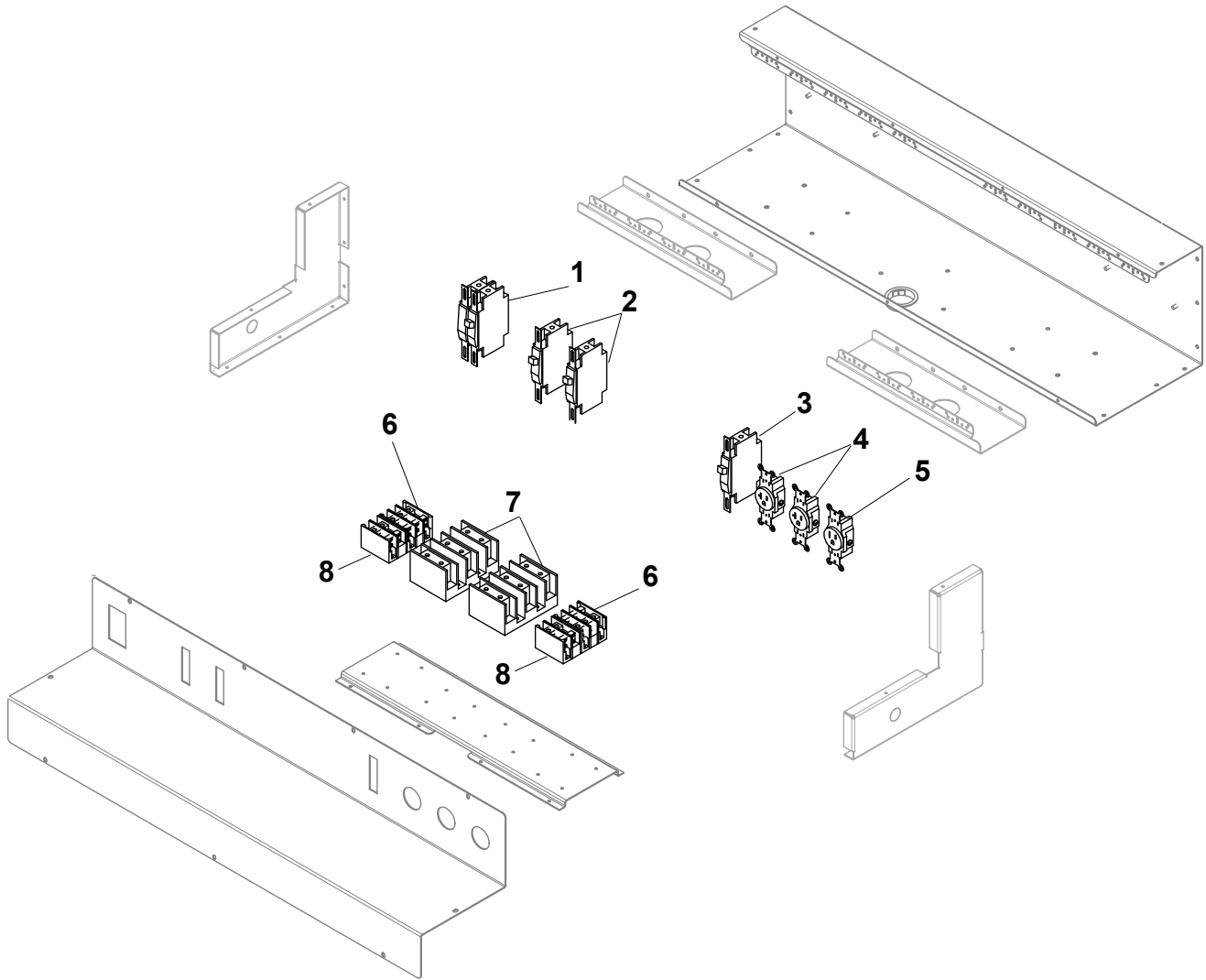

Figure: PL-5 Wire Chase: 36" Wide, Stand-Alone & Wall Units, FHUAS-2

ITEM	PN	DESCRIPTION	QTY
1	222602	BREAKER, 15A DBL POLE #QOU215	1
2	212997	BREAKER, SINGLE 1P 20A QOU120	2
3	212995	BREAKER, SINGLE 1P 10A QOU110	1
4	212337	RESEPTACLE, 5-20 SINGLE GRAY, 20A, 125V	2
5	212177	RECPT, ELEC 5-15 SINGLE HBL5261	1
6	212994	BLOCK, TERMINAL 3 POLE 9080LBA361104	2
7	222018	BLOCK, TERMINAL 3 CONN.	2
8	212993	BLOCK, TERMINAL 2 POLE 9080LBA261104	2

Table: PL-5 Wire Chase: 36" Wide, Stand-Alone & Wall Units, FHUAS-2

TELESCOPING SHELF ASSEMBLY FOR 32", 34" & 36" WIDE, FHUAS-2

RH PYLON TUNING PLATE SHOWN.

MOUNT WITH TEXT "RIGHT PYLON"
ON THE SAME SIDE AS SHELF PYLON.

LH PYLON TUNING PLATE SHOWN.

MOUNT WITH TEXT "LEFT PYLON"
ON THE SAME SIDE AS SHELF PYLON.

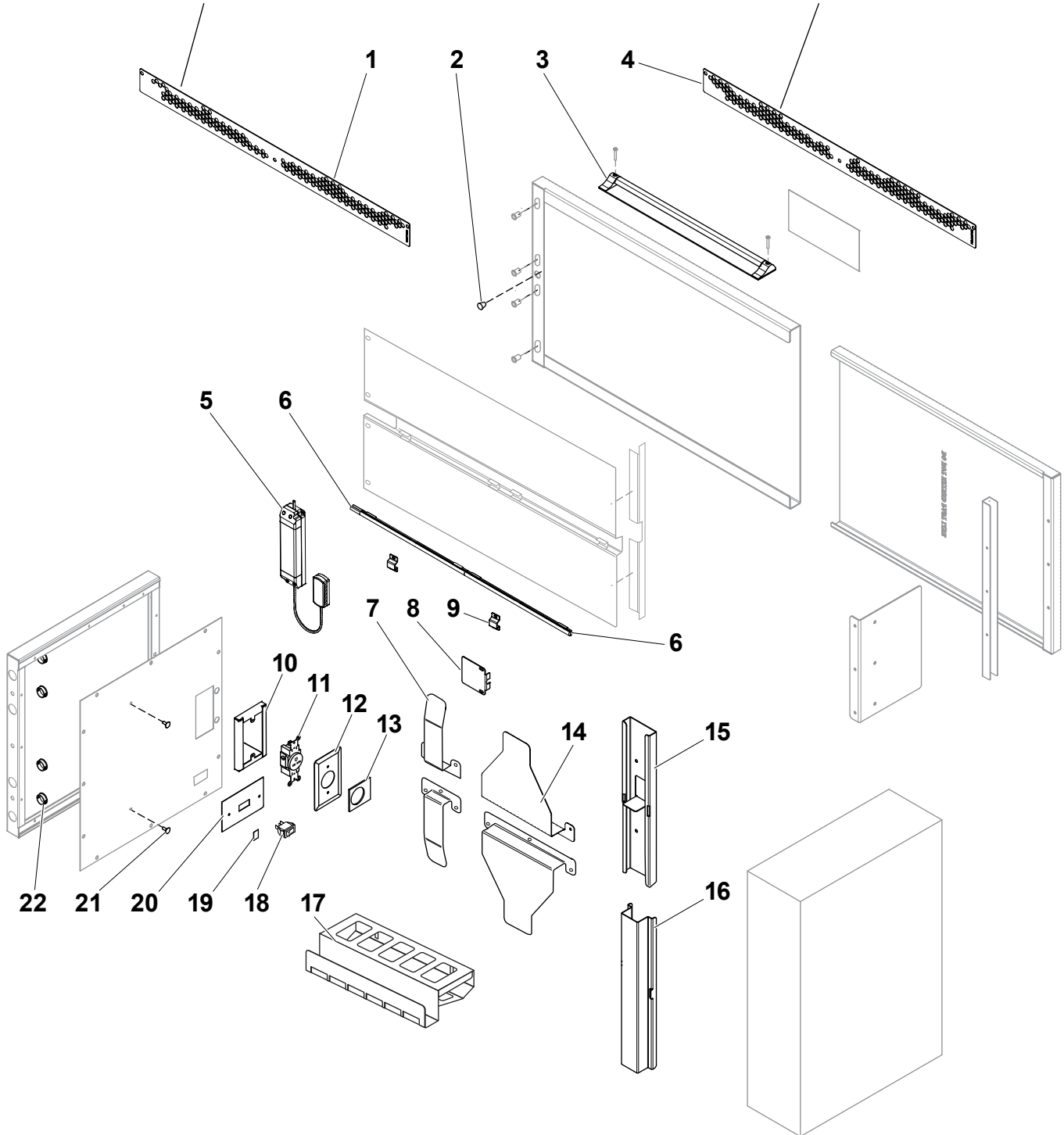

Figure: PL-6 Telescoping Shelf Assembly for 32" 34" & 36" Wide, FHUAS-2

TELESCOPING SHELF, ASSEMBLY FOR 32", 34" & 36" WIDE, FHUAS-2

ITEM	PN	DESCRIPTION	QTY
1	E050708	BALANCE PLATE (<i>Telescoping, RH, for 36" Wide, FHUAS-2</i>)	1
	1033-934	BALANCE PLATE (<i>Telescoping, RH & LH, for 32" & 34" Wide, FHUAS-2</i>)	
2	212047	BUSHING, HEYCO SB-500-6 3	1
3	225717	TICKET RAIL 18" #CK6518A	1
4	E050709	BALANCE PLATE (<i>Telescoping, LH, for 36" Wide, FHUAS-2</i>)	1
	1033-934	BALANCE PLATE (<i>Telescoping, RH & LH, for 32" & 34" Wide, FHUAS-2</i>)	
5	225855	DRIVER, LED, 24VDC 30W POWER SULLPY 120V 60HZ	1
6	225851	LIGHT, LED 12" CW 2.4W, 24VDC	1 or 2
	225852	LIGHT, LED 8" CW 1.6W, 24VDC	1
7	E050571	ONION SCOOP HOLDER, RETAINED, EXPEDITE	1
8	E030923	PANEL LIGHT COVER PHU SHELF	1
9	E020583	RETAINER LED RECESSED	2
10	E050782	2 × 4 OVERSIZED JBOX, FHUAS SHELF	1
11	212464	RECPT, 6-15R SINGLE BROWN 15A 250V	1
12	E050774	COVER, IRHS RECPT, NEMA 6-15	1
13	229383	LABEL, 6-15 IRHS FRY STATION CHASE	1
14	E050050	FRY SCOOP HOLDER, LARGE SIDE	1
15	E020892	BRACKET REMOVABLE TONG HOLDER	1
16	E020893	CHANNEL REMOVABLE TONG HOLDER	1
17	E050788	FRY RIBBON, 1-PIECE	1
18	212288	SWITCH, LIGHTED	1
19	214440	LABEL, OFF-SWITCH	1
20	222180	PLATE, ROCKER SWITCH UTILITY	1
21	213390	BOLT, CARRIAGE 10-24 × 1/2 SS MACHINE	2
22	212911	BUSHING, 7/8" HEYCO 2850	4
Not Shown	225861	CORD, LED SINGLE 98"	1
Not Shown	225465	HARNESS, IRHS RECEPTACLE	1

Table: PL-6 Telescoping Shelf Assembly for 32", 34" & 36" Wide, FHUAS-2

FREE STANDING SHELF ASSEMBLY FOR 32", 34" & 36" WIDE, FHUAS-2

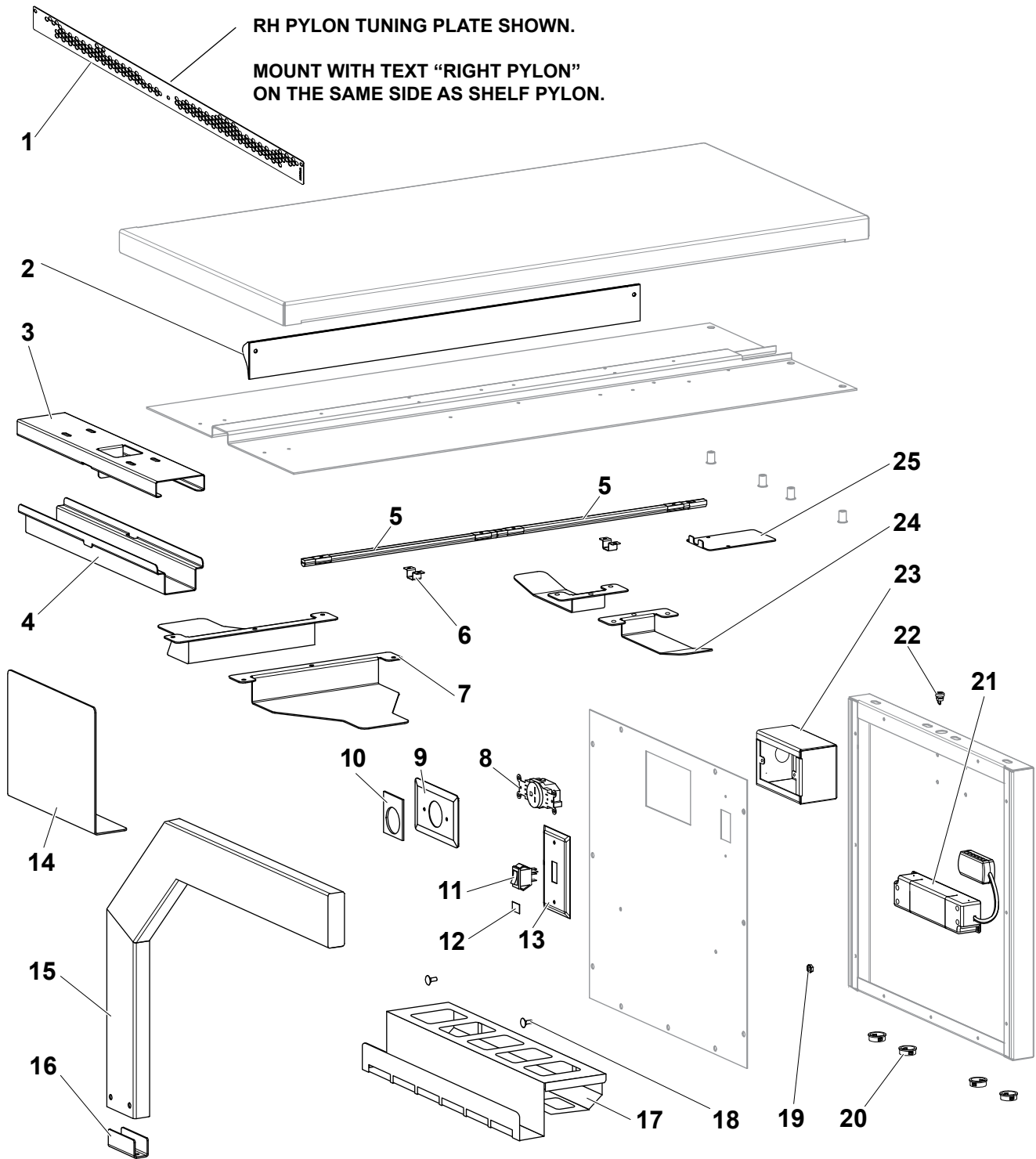

Figure: PL-7 Free Standing Shelf Assembly for 32" 34" & 36" Wide, FHUAS-2

FREE STANDING SHELF ASSEMBLY FOR 32", 34" & 36" WIDE, FHUAS-2

ITEM	PN	DESCRIPTION	QTY
1	E050708	BALANCE PLATE (<i>Free Standing, RH, for 36" Wide, FHUAS-2</i>)	1
	E050709	BALANCE PLATE (<i>Free Standing, LH, for 36" Wide, FHUAS-2</i>)	
	1033-934	BALANCE PLATE (<i>Free Standing, RH & LH, for 32" & 34" Wide, FHUAS-2</i>)	
2	225716	24" TICKET RAIL (<i>Free Standing, for 32" 34" & 36" Wide, FHUAS-2</i>)	1
	225717	18" TICKET RAIL (<i>Specail, Free Standing, 30" Wide Shelf, for 36" Wide FHUAS-2</i>)	
3	E020892	BRACKET REMOVABLE TONG HOLDER	1
4	E020893	CHANNEL REMOVABLE TONG HOLDER	1
5	225851	LIGHT, LED 12" CW, 2.4W, 24VDC	1
	225852	LIGHT, LED 8" CW, 1.6W, 24VDC	
6	E020583	RETAINER LED RECESSED	2
7	E050050	FRY SCOOP HOLDER, LARGE SIDE	2
8	212464	RECPT, 6-15R SINGLE BROWN 15A 250V	1
9	E050774	COVER, IRHS RECPT, NEMA 6-15	1
10	229383	LABEL, 6-15 IRHS FRY STATION CHASE	1
11	212288	SWITCH, LIGHTED	1
12	214440	LABEL, OFF-SWITCH	1
13	222180	PLATE, ROCKER SWITCH UTILITY	1
14	E020591	BRACKET SHELF SUPPORT EXPEDITE	1
15	E050745	SHELF LEG ASSEMBLY, WELDED	1
16	E020589	BRACKET SHELF LEG FOOT EXPEDITE	1
17	E050788	FRY RIBBON, 1-PIECE	1
18	213390	BOLT, CARRIAGE 10-24 × 1/2 SS MACHINE	2
19	213322	NUT KEPS 10-24	2
20	212911	BUSHING, 7/8" HEYCO 2850	4
21	225855	DRIVER, LED, 24VDC 30W POWER SULLPY 120V 60HZ	1
22	212047	BUSHING, HEYCO sb-500-6 3	1
23	E050782	2 × 4 OVERSIZED JBOX, FHUAS SHELF	1
24	E050571	ONION SCOOP HOLDER, RETAINED, EXPEDITE	2
25	E020776	PHU SHELF PANEL LIGHT COVER	1
Not Shown	225861	CORD, LED SINGLE 98"	1
Not Shown	225465	HARNES, IRHS RECEPTACLE	1

Table: PL-7 Free Standing Shelf Assembly for 32" 34" & 36" Wide, FHUAS-2

ENCLOSED BACK, SHELF ASSEMBLY FOR 32" 34" & 36" WIDE, FHUAS-2

LH PYLON TUNING PLATE SHOWN.

MOUNT WITH TEXT "LEFT PYLON"
ON THE SAME SIDE AS SHELF PYLON.

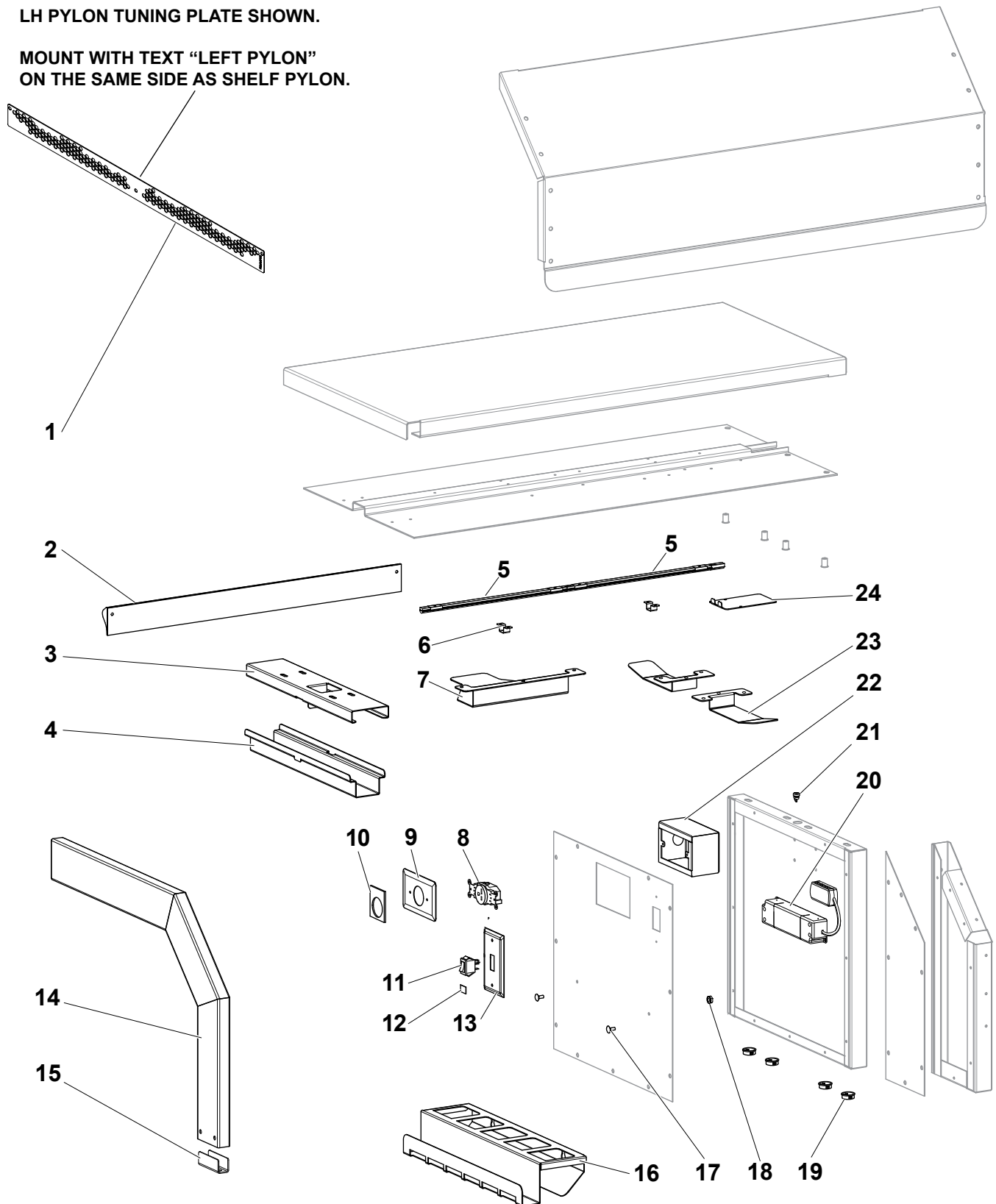

Figure: PL-8 Enclosed Back, Shelf Assembly for 32" 34" & 36" Wide, FHUAS-2

ENCLOSED BACK SHELF ASSEMBLY FOR 32" 34" & 36" WIDE, FHUAS-2

ITEM	PN	DESCRIPTION	QTY
1	E050708	BALANCE PLATE (<i>Enclosed, RH, for 36" Wide, FHUAS-2</i>), Not Shown	1
	E050709	BALANCE PLATE (<i>Enclosed, LH, for 36" Wide, FHUAS-2</i>), Shown	
	1033-934	BALANCE PLATE (<i>Enclosed, RH & LH, for 32" & 34" Wide, FHUAS-2</i>)	
2	225716	TICKET RAIL 24" #CK6524A	1
	225717	TICKET RAIL 18" #CK6518A	
3	E020892	BRACKET REMOVABLE TONG HOLDER	1
4	E020893	CHANNEL REMOVABLE TONG HOLDER	1
5	225851	LIGHT, LED 12" CW 2.4W, 24VDC	1 or 2
	225852	LIGHT, LED 8" CW 1.6 W, 24VDC	1
6	E020583	RETAINER LED RECESSED	2
7	E050050	FRY SCOOP HOLDER, LARGE SIDE	2
8	212464	RECPT, 6-15R SINGLE BROWN 15A 250V	1
9	E050774	COVER, IRHS RECPT, NEMA 6-15	1
10	229383	LABEL, 6-15 IRHS FRY STATION CHASE	1
11	212288	SWITCH, LIGHTED	1
12	214440	LABEL, OFF-SWITCH	1
13	222180	PLATE, ROCKER SWITCH UTILITY	1
14	E050745	SHELF LEG ASSEMBLY, WELDED	1
15	E020589	BRACKET SHELF LEG FOOT EXPEDITE	1
16	E050788	FRY RIBBON, 1-PIECE	1
17	213390	BOLT, CARRIAGE 10-24 × 1/2 SS MACHINE	2
18	213322	NUT KEPS 10-24	2
19	212911	BUSHING, 7/8" HEYCO 2850	5
20	225855	DRIVER, LED, 24VDC 30W POWER SULLPY 120V 60HZ	1
21	212047	BUSHING, HEYCO SB-500-6 3	1
22	E050782	2 × 4 OVERSIZED JBOX, FHUAS SHELF	1
23	E050571	ONION SCOOP HOLDER, RETAINED, EXPEDITE	2
24	E020776	SHELF PANEL LIGHT COVER	1
Not Shown	E020591	BRACKET SHELF SUPPORT EXPEDITE	1
Not Shown	225861	CORD, LED SINGLE 98"	1
Not Shown	225465	HARNESS, IRHS RECEPTACLE	1

Table: PL-8 Enclosed Back, Shelf Assembly for 32" 34" & 36" Wide, FHUAS-2

HOW TO DETERMINE MANUFACTURE DATE FROM DUKE EQUIPMENT SERIAL NUMBERS

How to Determine Manufacture Date from Duke Equipment Serial Numbers

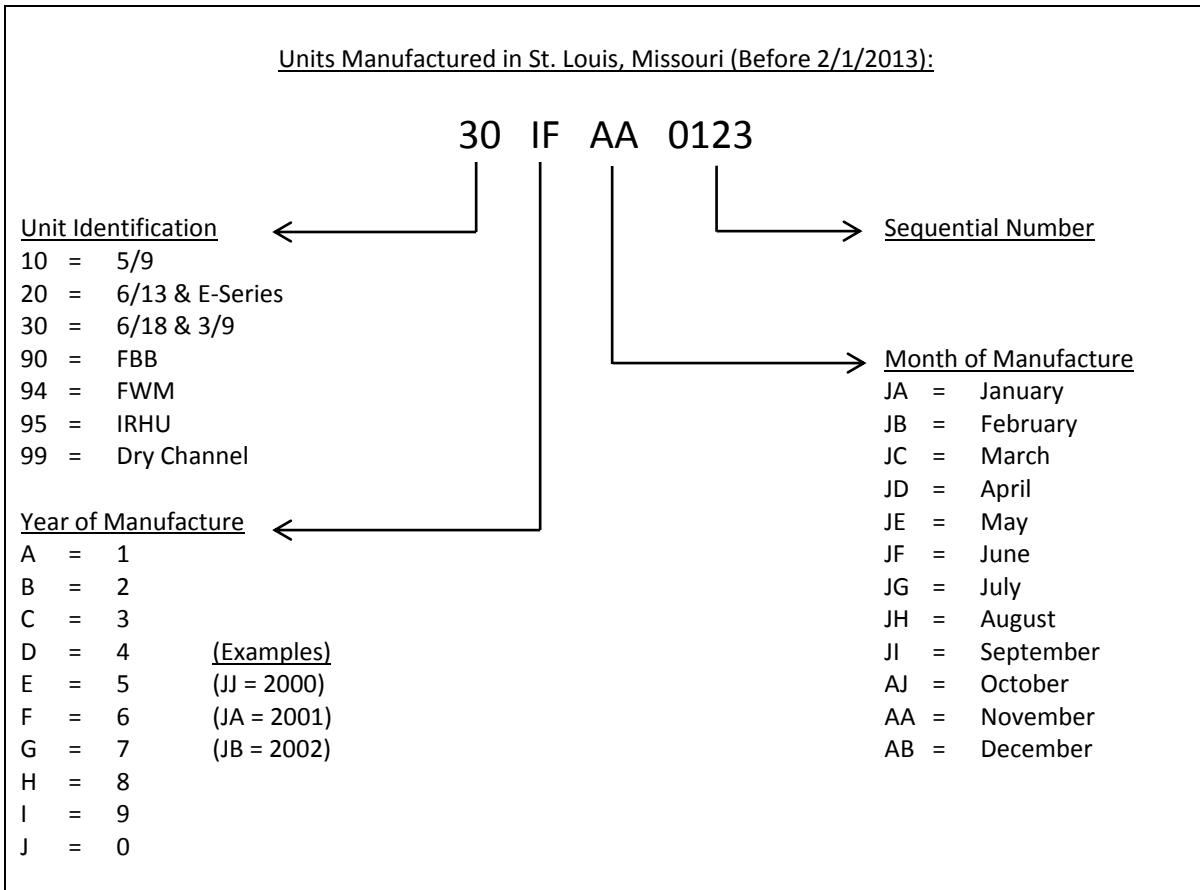
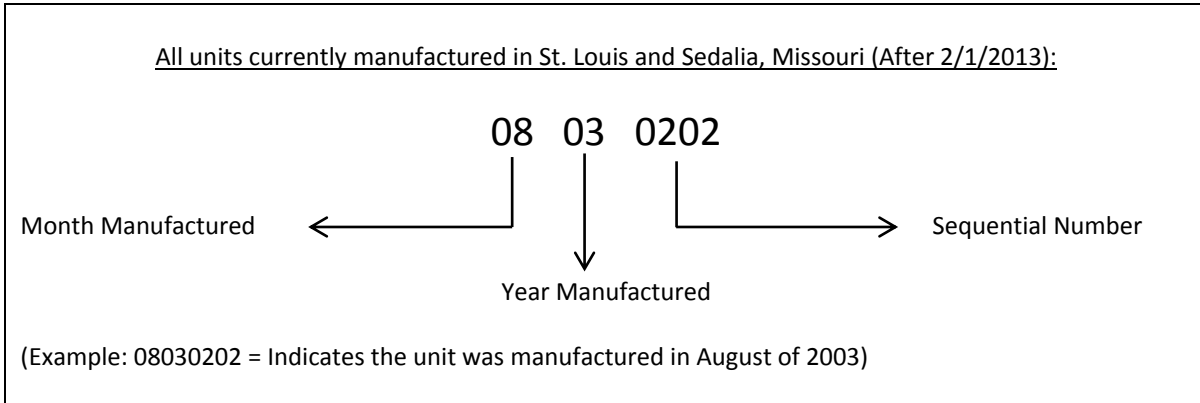



Your Solutions Partner

Duke Manufacturing Company

**2305 N. Broadway
St. Louis, MO 63102
Phone: 314-231-1130
Toll Free: 1-800-735-3853
Fax: 314-231-5074
www.dukemfg.com**