

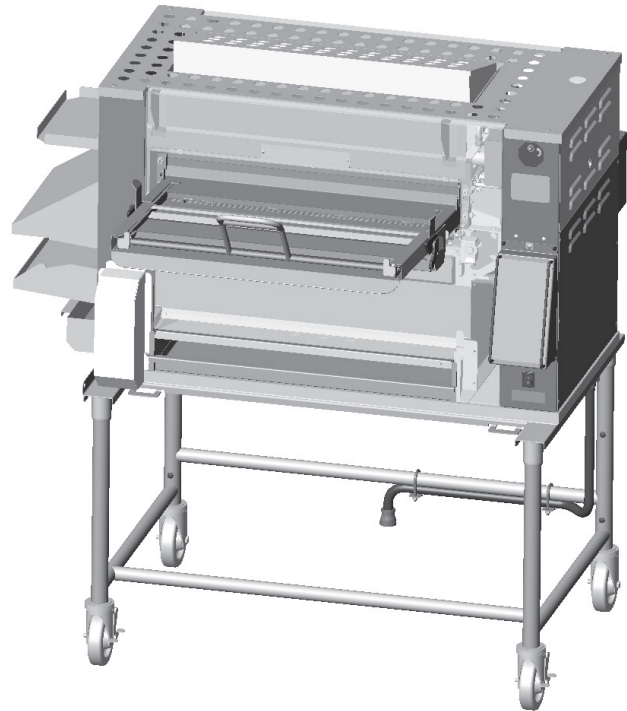

*Your Solutions Partner*

# **Installation and Operation Manual**

## **BURGER KING FLEXIBLE BATCH BROILER WITH TOUCH SCREEN CONTROL**



**Please read this manual completely before attempting  
to install, operate or service this equipment**

---

*This manual is Copyright © 2017 Duke Manufacturing Co. All rights reserved.  
Reproduction without written permission is prohibited. Duke is a registered  
trademark of the Duke Manufacturing Co.*

### **Duke Manufacturing Co.**

**2305 N. Broadway  
St. Louis, MO 63102  
Phone: 314-231-1130  
Toll Free: 1-800-735-3853  
Fax: 314-231-5074  
[www.dukemfg.com](http://www.dukemfg.com)**

---

**P/N 176747B  
03/06/2017**



## TABLE OF CONTENTS

IMPORTANT WARNING AND SAFETY INFORMATION .....	4
I. GENERAL INFORMATION .....	5
A. BATCH BROILER SPECIFICATIONS .....	5
II. INSTALLATION INSTRUCTIONS .....	7
A. VENTILATION .....	7
B. INSTALLATION SPECIFICATIONS .....	8
C. DELIVERY AND INSPECTION .....	8
D. BROILER ASSEMBLY .....	10
E. ADJUSTMENTS AT INSTALLATION .....	11
F. LOCATION OF THE BROILER .....	12
G. GAS PIPING.....	12
H. ELECTRICAL CONNECTIONS .....	12
III. OPERATION INSTRUCTIONS.....	14
A. DAILY BROILER START-UP .....	15
B. COOKING PRODUCT.....	16
C. SPECIAL FUNCTION SCREENS .....	18
D. CLEANING .....	23
IV. SERVICE AND REPAIR.....	31
V. REPLACEMENT PARTS LIST.....	33
VI. ELECTRICAL SCHEMATIC .....	35

## IMPORTANT WARNING AND SAFETY INFORMATION

 **WARNING** HAZARD WHICH COULD RESULT IN DEATH OR SERIOUS INJURY

 **CAUTION** HAZARD WHICH COULD RESULT IN MINOR OR MODERATE INJURY



**ELECTRICAL SHOCK HAZARD WHICH COULD RESULT IN DEATH OR SERIOUS INJURY AND/OR EQUIPMENT DAMAGE**



**HOT SURFACE WHICH COULD RESULT IN MINOR OR MODERATE INJURY.**



**TASKS MUST BE PERFORMED ONLY FOLLOWING PROPER TRAINING**

- Read all instructions before using equipment
- Do not attempt to defeat the grounded connector
- Install or locate the equipment, only for its intended use, as described in this manual.
- Do not use corrosive chemicals, water jet equipment, or other pressurized liquid spraying equipment to clean this unit.
- Do not block any openings on the unit.
- Unit may start operating with inadvertent contact with the touch screen display or from other extraneous sources. Turn off external mains supply disconnect and/or unplug the unit from the mains supply, should abnormal or unwanted operations occur.
- This appliance is not intended for use by children or persons with reduced physical, sensory or mental capabilities, or lack of experience and knowledge unless they have been given supervision or instruction concerning use of the appliance by a person responsible for their safety. Children shall not play with the appliance.
- Turnoff the external mains supply disconnect or disconnect the appliance line supply cord and allow the unit to cool down before servicing or performing maintenance.
- The procedures in this manual may include the use of chemical products. You must read the Material Safety Data Sheets (MSDS) before using any of these products.
- Properly rated all poles mains protection and earthing compliance with local codes are required for safe operation of this unit.
- Disposal of this unit must be in accordance with local environmental codes and/or other applicable codes.
- Consult the local gas supplier for instructions to be followed in the event user smells gas.
- Do not store or use gasoline or other flammable vapors or liquids in the vicinity of this or any other appliance.
- **SAVE THESE INSTRUCTIONS**

## I. GENERAL INFORMATION

### A. Batch Broiler Specifications

FLEXIBLE BATCH BROILER SPECIFICATIONS				
	NATURAL GAS		PROPANE	
ALTITUDE (MAXIMUM)	2000 FT	607 m	2000 FT	607 m
GAS PIPE CONNECTION	3/4" F-NPT		3/4" F-NPT	
INLET PRESSURE RANGE	7" – 12" W.C.		10" – 12" W.C.	
NOTE: High Pressure Kit is required if supply pressures are greater than 12.0" W.C. (3.0 kPa) Reference Duke P.N. <a href="#">175689</a>				
	MANIFOLD PRESSURE		MANIFOLD PRESSURE	
INFRARED BURNERS (TOP)	3.75" W.C.	0.93 kPa	8.0" W.C.	2.0kPa
LOWER BURNER	3.75" W.C.	0.93 kPa	8.0" W.C.	2.0kPa
TOTAL ENERGY RATE	87000 – 111,000 BTU/HR	25.5 – 32.5 kW	79,000 – 105,000 BTU/HR	23.2 – 30.7 kW
	BURNER ORIFICE SIZE		BURNER ORIFICE SIZE	
FRONT INFRARED BURNER	#40	2.49mm	#52	1.61mm
BACK INFRARED BURNER	#36	2.70mm	#51	1.70mm
LOWER BURNER	#31	3.05mm	#49	1.85mm

**SHIPPING WEIGHT:** 482 lbs (219 Kg)

**SHIPPING DIMENSIONS:** 47" x 34" x 68" (119.4 x 86.4 x 172.7 cm)

MODEL NUMBER	ELECTRIC	NATURAL & LP GAS
FBBT-NO-120	120VAC, 2A, 60Hz	87,000 – 111,000 BTU/HR
FBBT-NC-120	120VAC, 2A, 60Hz	87,000 – 111,000 BTU/HR
FBBT-PO-120	120VAC, 2A, 60Hz	79,000 – 105,000 BTU/HR
FBBT-PC-120	120VAC, 2A, 60Hz	79,000 – 105,000 BTU/HR

#### A-1.0 Model Number Key

FBBT-XY-120

X = N (NATURAL GAS) OR P (PROPANE / LP GAS)

Y = O (NO CATALYST) OR C (CATALYST)

120 = 120 VOLTS

# Installation and Operation of Flexible Batch Broiler With Touch Screen Control

## A-2.0 Broiler Dimensions

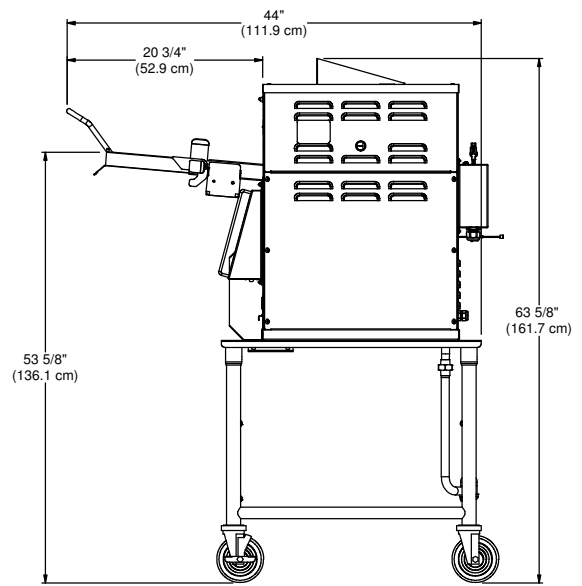
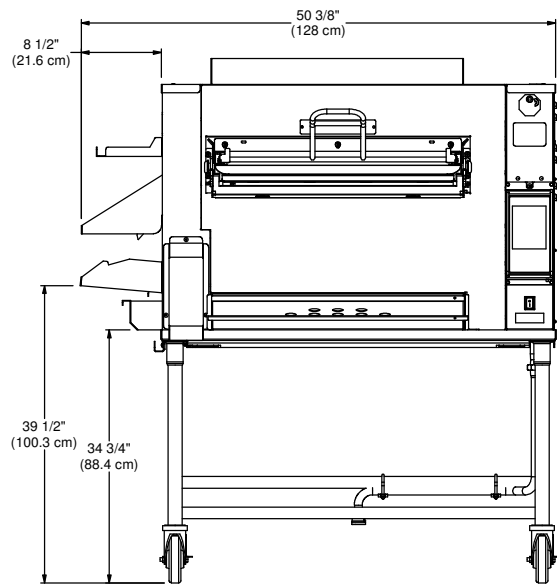
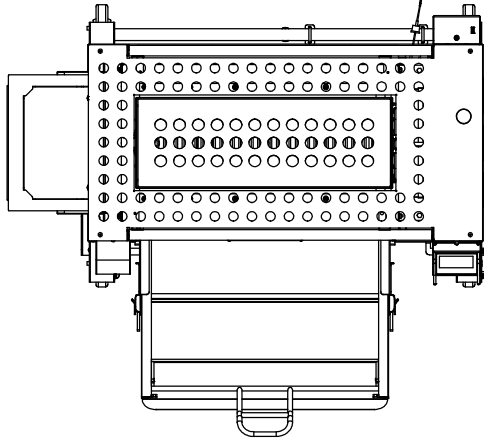

## II. INSTALLATION INSTRUCTIONS

The installation must conform with local codes, or in the absence of local codes, with the National Fuel Gas Code,

### **WARNING**

**IMPROPER INSTALLATION, ADJUSTMENT, ALTERATION, SERVICE, OR MAINTENANCE CAN CAUSE PROPERTY DAMAGE, INJURY, OR DEATH. READ THE INSTALLATION, OPERATING, AND MAINTENANCE INSTRUCTIONS BEFORE INSTALLING OR SERVICING THIS EQUIPMENT.**

Installation and/or service repair of gas appliances requires Skilled or Qualified Personnel. Skilled or Qualified Personnel are individuals, firms, companies or corporations which are directly authorized by Duke Manufacturing (Assignee) or meet the requirements of governmental authority having jurisdiction for the task.

Electrical wiring tasks must be in conformance with National Electrical Code ANSI/NFPA70

Gas supply interconnection must be in conformance with National Fuel Gas Code ANSI Z223.1/NFPA54 and Natural Gas and Propane Installation Code CSAB149 including the following:

- The appliance must have an individual manual shutoff valve at the connection to the gas supply piping system during any pressure testing of that system at test pressures in excess of ½ psi (3.5kPa).
- The appliance must be isolated from the gas supply piping system by closing its individual manual shut off valve during any pressure testing of the gas supply systems at test pressures equal to or less than ½ psi (3.5kPa).

For a broiler mounted on casters, the installation must be made with a connector

that complies with ANSI Z21.69 / CSA 6.16 Connectors for Moveable Gas Appliances and a quick-disconnect device that complies with ANSI Z21.4 / CSA 6.9 Quick –Disconnect Devices for Use with Gas Fuel.

When installing a broiler mounted on casters with quick-disconnect hose, adequate means must be provided to limit the movement of the broiler without depending on the connector, hose, or system piping to limit movement. A restraining device may be attached to the rear vertical portion of the broiler's base frame.

### **A. VENTILATION:**

This appliance requires a ventilation system to prevent unacceptable concentrations of substances harmful to health in the room where the appliance is installed.

Ventilation System Specifications:

Must be a Mechanically Driven Exhaust Hood System

Minimum Capacity: 1,700 m<sup>3</sup>/hr (1,000 cfm)  
Minimum Opening: 39.4" x 51.2" (100cm x 130cm)

The Ventilation System must be inspected, maintained, and annually serviced by Qualified Personnel as part of or in addition to governmental requirements

**NOTE: Ventilation Systems for multiple or additional appliances must have capacity in addition to the specifications for this appliance.**

### Maintenance of Ventilation System

The ventilation system must be maintained and annually inspected by Qualified Personnel concurrent as part of or in addition to governmental requirements.

This inspection/maintenance should consist of, but not be limited to:

- Inspection for blockages or build up which might interfere with the venting of the broiler.
- Repair of such blockages.
- Inspection of the venting canopy, its drive motors and bells, etc.

**NOTICE:** Do not place any objects such as sheet pans, food containers or aluminum foil on the top of the broiler. This will obstruct the venting of cooking vapors and airflow through the unit—resulting in poor cooking performance.

### B. INSTALLATION SPECIFICATIONS:

The broiler has been fully tested before shipping with adjustments to optimize operation of the gas system IR (top) burners and bottom burner. The Skilled or Qualified Personnel installing the broiler must verify gas systems adjustments to verify adjustments were not impacted during transit shipping. Please contact Duke Manufacturing Co. for adjustment procedures.

This broiler must not be installed on a curb base or sealed to a wall. The area around the broiler must be clear of combustible materials.

Minimum clearances to combustible or noncombustible surfaces are:

Discharge end: 12.0" (305mm)  
Rear of unit: 4.0" (102mm)

Side Access Panel (Control): 3.0" (76mm)  
Floor / Table: 0" (0mm)

### ELECTRICAL SPECIFICATIONS:

Electrical Rating: 120V~ 2A 60Hz  
Line Connection: NEMA 15



**ELECTRICAL SHOCK HAZARD  
UNIT MUST BE SAFETY  
GROUNDED, EARTHED.**

**DO NOT MODIFY OR DEFEAT  
ELECTRICAL CONNECTIONS**

### C. DELIVERY AND INSPECTION

- The shipping carrier assumes liability and responsibility for delivering the appliance without damage. Duke Manufacturing Co. can assist with resolution of any shipping related issues if a problem arises.
- Look over the outer shipping container carefully when delivered with the person making the delivery.
- Note any exterior damage on the delivery receipt before signing.
- The person making the delivery for the shipping carrier must agree and sign the receipt to document damage to the outer shipping container.
- Unpack the broiler and inspect for any damage not evident on the outer shipping container and other concealed damage. The shipping carrier must be notified any damages within fifteen (15) days of receipt.

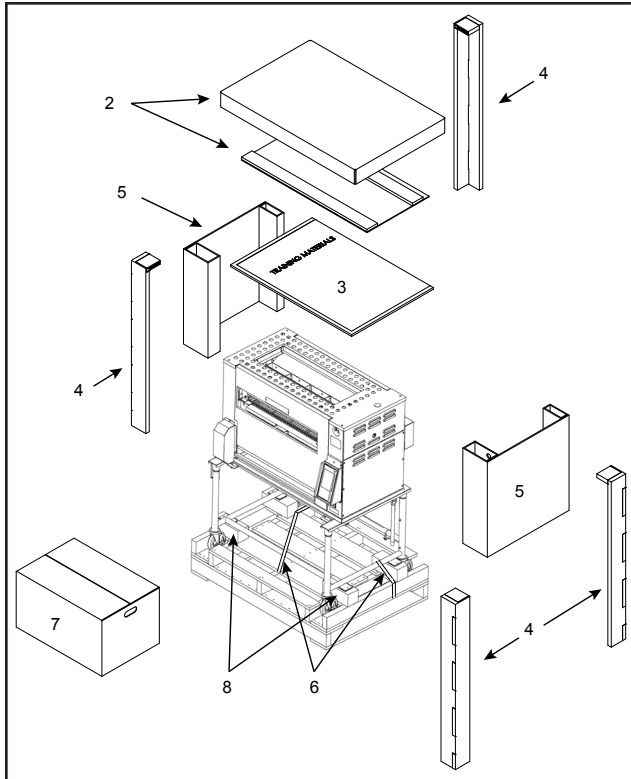

**CAUTION**

The broiler is very heavy!  
Use adequate help when lifting.

1. Cut away the plastic outer wrap.
2. Remove the top cardboard and inner cap (Item 2)
3. Remove training material box (Item 7)
4. Remove cardboard corner covers (Item 4)
5. Remove cardboard ends (Item 5)
6. Cut banding straps with a utility knife or scissors (Items 6)
7. Remove accessories box (Item 8) checking that no tape remains.
8. Lift one end of the broiler and tap the wood block toward the center and then sideways to remove. Repeat for the remaining blocks allowing the casters to rest on the pallet.
9. A minimum of three (3) people are required to support and balance the broiler while removing from the pallet.
  - a. Roll the broiler forward until the front caster are clear of the pallet
  - b. Lift the broiler rear caster above the pallet and slide out the pallet from under the broiler.
  - c. Gently lower the broiler to the floor to avoid damage to casters
10. Remove the protective blue tape protecting the broiler stainless steel panels. Verify all blue tape is removed before installing and operating the unit.

### D. BROILER ASSEMBLY

Before assembling and installing the broiler, please check to make sure that all necessary parts are present.

ITEM	PART NAME	PT.NO.
1	PRODUCT PAN SHELF	175353
2	DISCHARGE CHUTE	175340
3	DISCHARGE HOOD	175778
4	DISCHARGE PAN HOLDER	175358
5	DISCHARGE GREASE PAN	175357
6	"V" GREASE PAN	175325
7	MAIN GREASE PAN	175329
8	LOADER	175444
9	LOADER TRAY	175430
10	LOADER BRACKET	175438
11	DOOR	175429
12	LOADER RAMP	175741
13	IMPEDANCE PAN	175226
14	CATALYST (OPTIONAL)	175480
15	CATALYST GUARD (OPTIONAL)	175482
16	SANITATION PAIL	175842
17	KIT, CLEANING TOOLS/INSTALLATION TOOL CLEANING – LOWER BURNER FLAME ROD TUBE CLEANER BRUSH, TUBE CLEANER TOOL– LOADER INSTALL WRENCH, ALLEN, 3/16"	175700
18	KIT – BROILER SVC. PARTS, NAT. GAS W/ CONTROLLER W/COOK CHAIN (OPTIONAL)	
19	KIT – BROILER SVC. PARTS, PROPANE, W/ CONTROLLER W/COOK CHAIN (OPTIONAL)	
20	KIT – USER REPLACEABLE, BOTTOM BURNER, FLAME ARRESTOR, LOADER & BURNER SHIELD (OPTIONAL)	175726
21	KIT – USER REPLACEABLE, BOTTOM BURNER & FLAME ARRESTOR (OPTIONAL)	175750
22	KIT – GAS HOSE CONNECTOR ASSEMBLY (OPTIONAL)	175690
23	KIT – HIGH SUPPLY GAS PRESSURE REGULATOR (OPTIONAL)	175689

### Setup

Install all items as shown below.

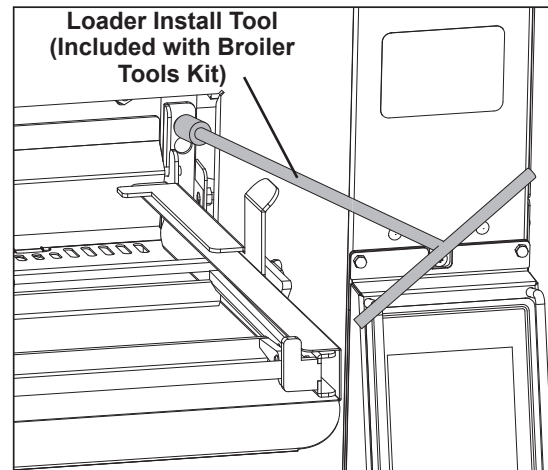
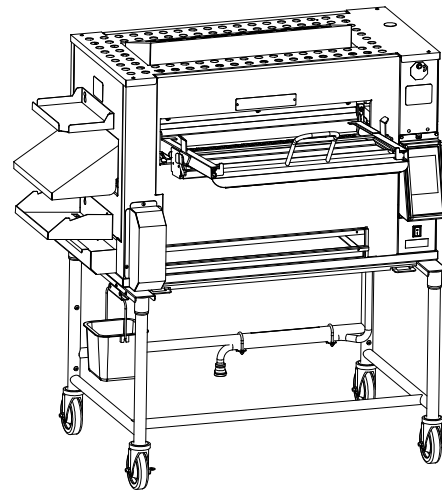

Install loader bracket with (4) 1/4-20 nuts.

Use supplied extension tool to remove and reinstall nuts. (Nuts are shipped installed on loader mounting studs.)

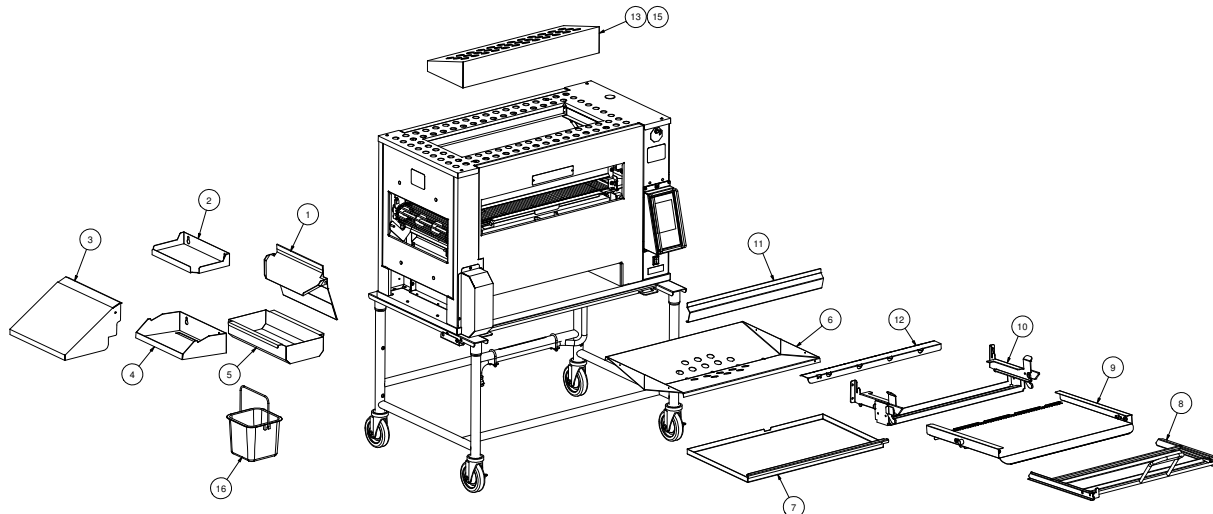

## E. ADJUSTMENTS AT INSTALLATION

Each broiler section and all its component parts have been tested thoroughly and inspected before your broiler was shipped from the factory. However, it is sometimes necessary to further test or adjust the broiler once it has been installed. Such adjustments are the responsibility of the Dealer or Installer. These types of adjustments are not considered defects, rather a normal and routine part of the proper installation of the equipment.

These adjustments include but are not limited to:

- Adjustments to the gas pressure regulator
- Broiler height adjustment (if required)

No installation should be considered complete without proper inspection and, if necessary, any adjustments by qualified service or installation personnel.

It is also important not to obstruct the natural flow of combustion and ventilation air if the broiler is to operate properly. This broiler should not be installed on a curb base or sealed to the wall. Either condition can restrict the flow of air to the combustion compartment or prevent proper ventilation of the unit. Before making any connections to the broiler, check the ratings plate to be sure the broiler specifications concur with the type of gas and voltage to be supplied to the broiler.

The rating plate is located on the back of the control compartment cover panel on the right end of the unit.

The plate bearing the broiler's model number and serial number is attached to the back side of the unit.

### Raise or Lower Broiler

The broiler height can be adjusted via two screws on each leg.

**CAUTION**

**The Broiler is very heavy! Use adequate help for lifting.**

1. Lift one end of the broiler onto a wide, sturdy stand (not supplied).
2. Remove (2) screws per leg and raise/lower to threaded holes. Reinstall screws.
3. Remove stand and safely raise/lower broiler.
4. Place plastic hole plugs (supplied attach to stand) in any unused holes.

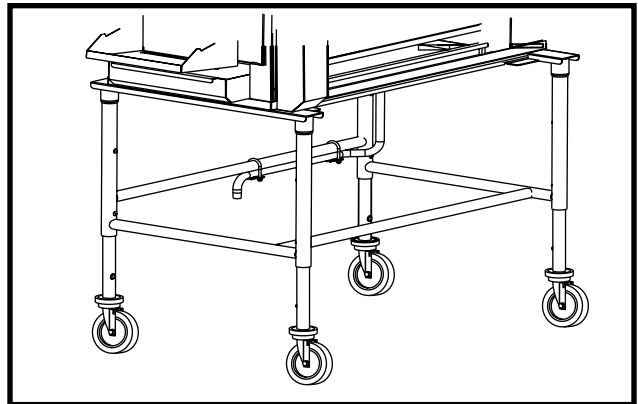

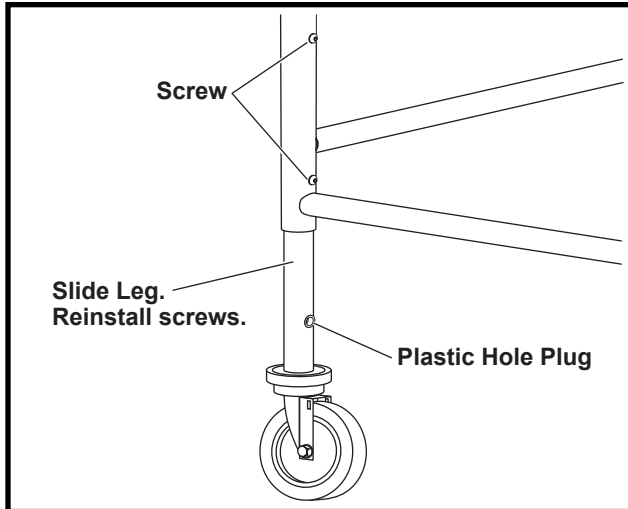

Your local gas supplier should consult the National Fuel Gas Code for proper sizing and installation of gas piping. Generally, piping should be sized to provide a gas supply sufficient to meet the maximum demand of all gas appliances on a line without undue loss of pressure at the outlet to the equipment. The total BTU requirements of the equipment being served and the length of the piping from the meter to the appliances are major considerations in the proper design of the gas supply system.

**NOTICE:** Using the Loader Tray to support heavy items or an individual's body weight can damage components of the broiler.

## F. LOCATION OF THE BROILER

Proper planning and placement of the broiler will give you the best results in terms of long-term user convenience and satisfactory performance. We urge you to give adequate thought in the placement of your broiler prior to its arrival.

- The broiler should be placed in an area that is free from drafts and accessible for proper operation and servicing.
- The area around the broiler must be kept clear of combustible materials. A minimum clearance of:

	Combustible	Non-Combustible
Discharge End	12" (305)	12" (305)
Access Panel End	3" (76)	3" (76)
Rear	4" (102)	4" (102)
Floor/Table	0" (0)	0" (0)

## G. GAS PIPING

The standard broiler consumes gas at a total of 100,000 BTU/hr. In order to achieve the degree of performance for which the unit has been designed, the overall piping plan of the kitchen, properly sized, is essential. The installation of this broiler must conform with all local codes, or in the absence of any local codes, to the National Fuel Gas Code, NFPA 54 and ANSI Z 223.1.

## NOTICE TO INSTALLER:

THIS APPLIANCE SHALL BE CONNECTED TO A GAS SUPPLY IN THE RANGE OF:

NATURAL GAS 7" TO 12" W.C.

PROPANE GAS 10" TO 12" W.C.

Gas supply pressure must be checked prior to installation. If supply pressure is in excess of 12" W.C., The *HIGH SUPPLY PRESSURE KIT*, Duke P/N [175689](#) shall be installed and adjusted, per kit instructions, for an outlet pressure of:

Natural Gas - 7" W.C.

Propane Gas – 11" W.C.

**NOTE:** A fixed restraint of the proper length must be incorporated to secure the broiler to a non-movable surface to eliminate strain on the gas connector. If the broiler is removed from its normal position, the restraint must then be reattached when returned.

## H. ELECTRICAL CONNECTIONS

Your broiler is supplied for connection to a dedicated 120 volt, grounded circuit. The electric motors, indicator lights and control circuits are connected through a seven-foot electric supply cord found at the rear of the broiler.

Before making any connections to these units, check the rating plate to assure that the voltage and phase of the broiler is compatible with the electrical supply. When installing, all broilers must be electrically grounded in accordance with local codes, or in the absence of local codes, with the National Electrical Code, ANSI/NFPA 70 (in Canada - CSA Std. C22.2). Wiring diagrams are located in the control compartment area of the broiler. Standard wiring schematics are also provided with this manual.

** WARNING:** This appliance is equipped with a three-prong (grounding) plug for your protection against shock hazard and should be plugged directly into a properly grounded three-prong receptacle. DO NOT cut or otherwise remove the grounding prong from this plug.

### III. OPERATION INSTRUCTIONS

#### TOUCH SCREEN CONTROL DEFINITIONS

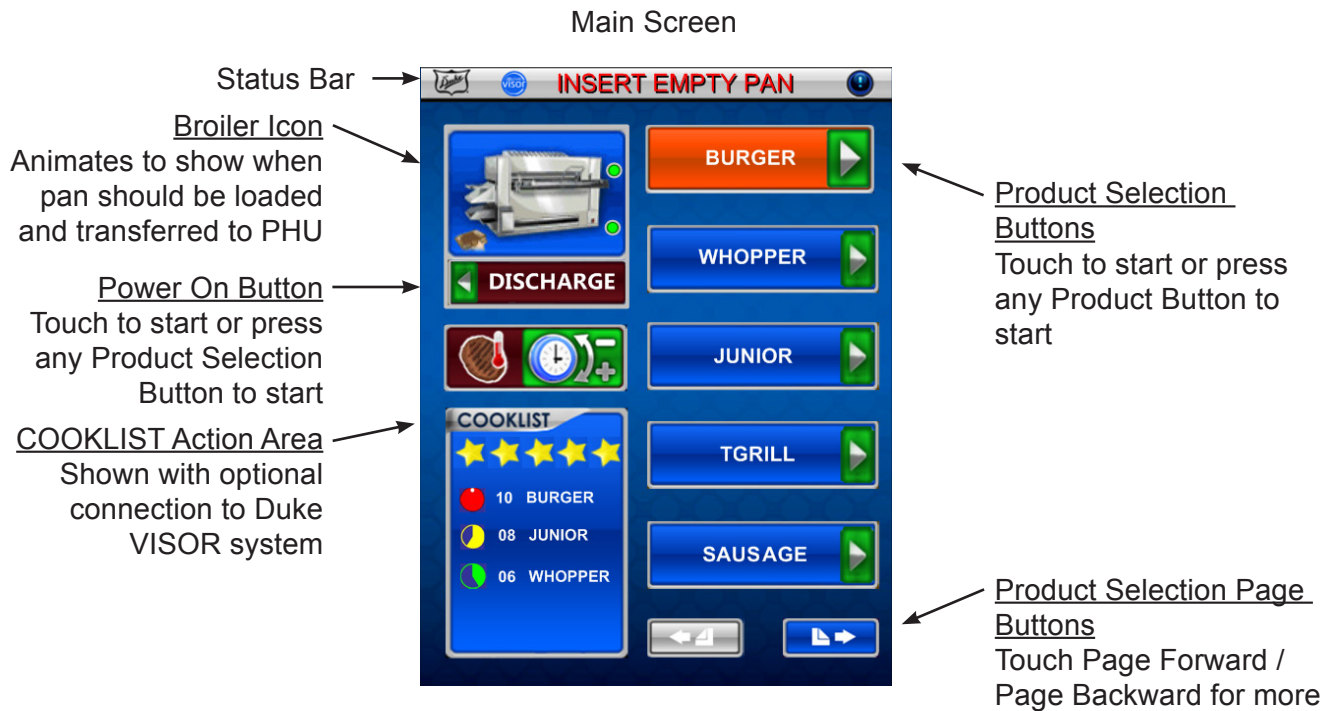
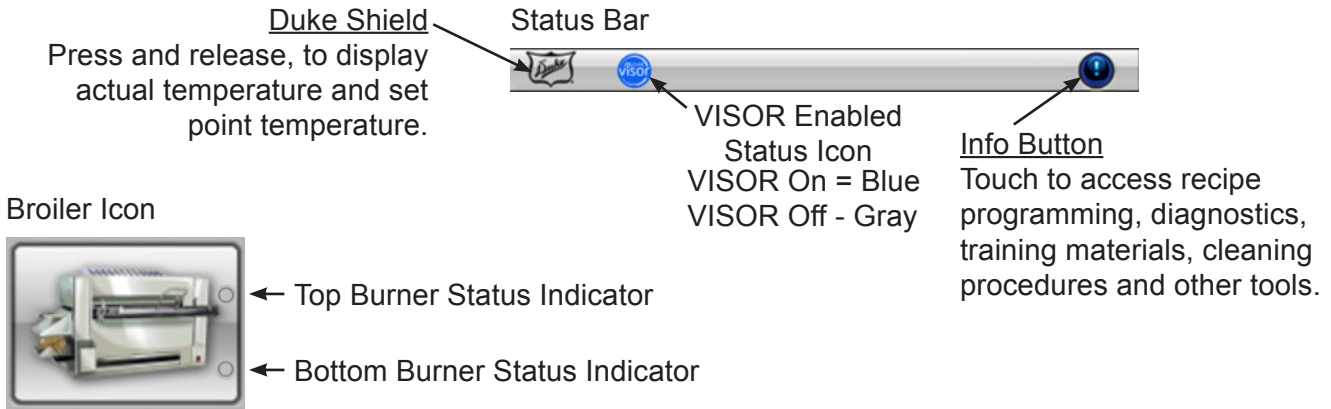

#### AUDIBLE ALARMS

The Broiler has various audible alarms as shown below.

1 chirp	Keystroke acknowledgement
3 short chirps	Broiler preheat complete notification
6 beeps	Broiler discharge (Default setting)
6 beeps (Continuous unit cleared)	Fault (Default setting)

### A. DAILY BROILER START-UP

1. Start the ventilation system. Turn the ON/OFF power switch to the ON (I) position. The boot screen will display and then automatically transition to the main off screen.



Figure: Boot Screen



Figure: Main Off Screen



2. Turn the Broiler on by touching the power on button  or a recipe button (i.e. ). The top burner and bottom burner lights will turn green and switch to the preheating screen.
3. Allow to the Broiler to preheat to 680°F. The Broiler will then enter the starting up screen for 10 minutes to stabilize temperature.



Figure: Preheating Screen

Display of Starting Up Time  
(10 Minutes Total)

Display of Actual  
Temperature

- Top Burner Status (Green = ON, Gray = OFF)
- Top Flame Sensor (Green = ON, Gray = OFF)
- Bottom Flame Sensor (Green = ON, Gray = OFF)
- Bottom Burner Status (Green = ON, Gray = OFF)

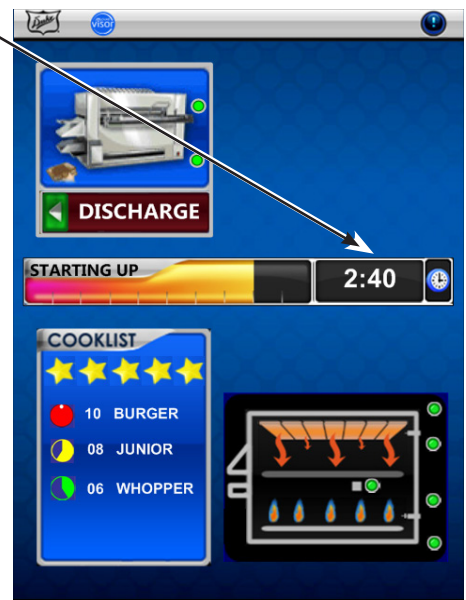

Figure: Starting Up Screen

## B. COOK PRODUCT

1. After startup is complete the Ready Screen appears. The ability to begin a cook cycle is now available through the press of product buttons, per the programmed recipes. The “Do Not Load” light will be lit after a cook cycle has started. See the details below for loading product and beginning a cook cycle.

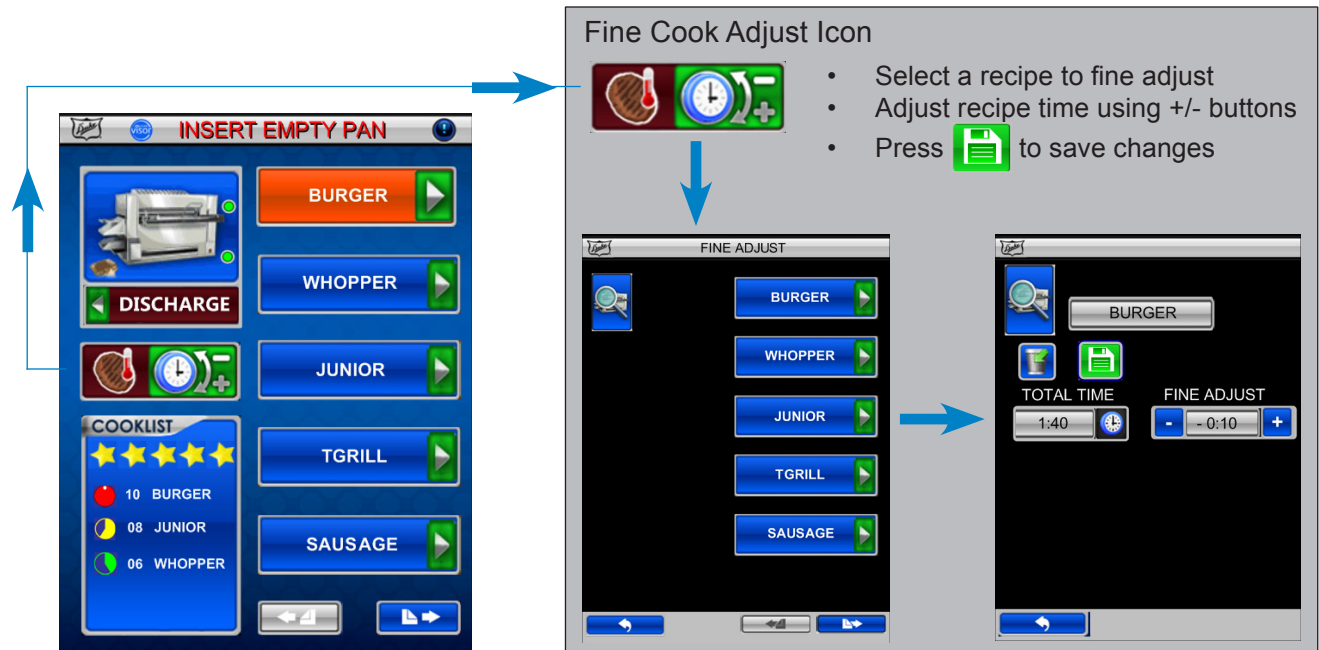
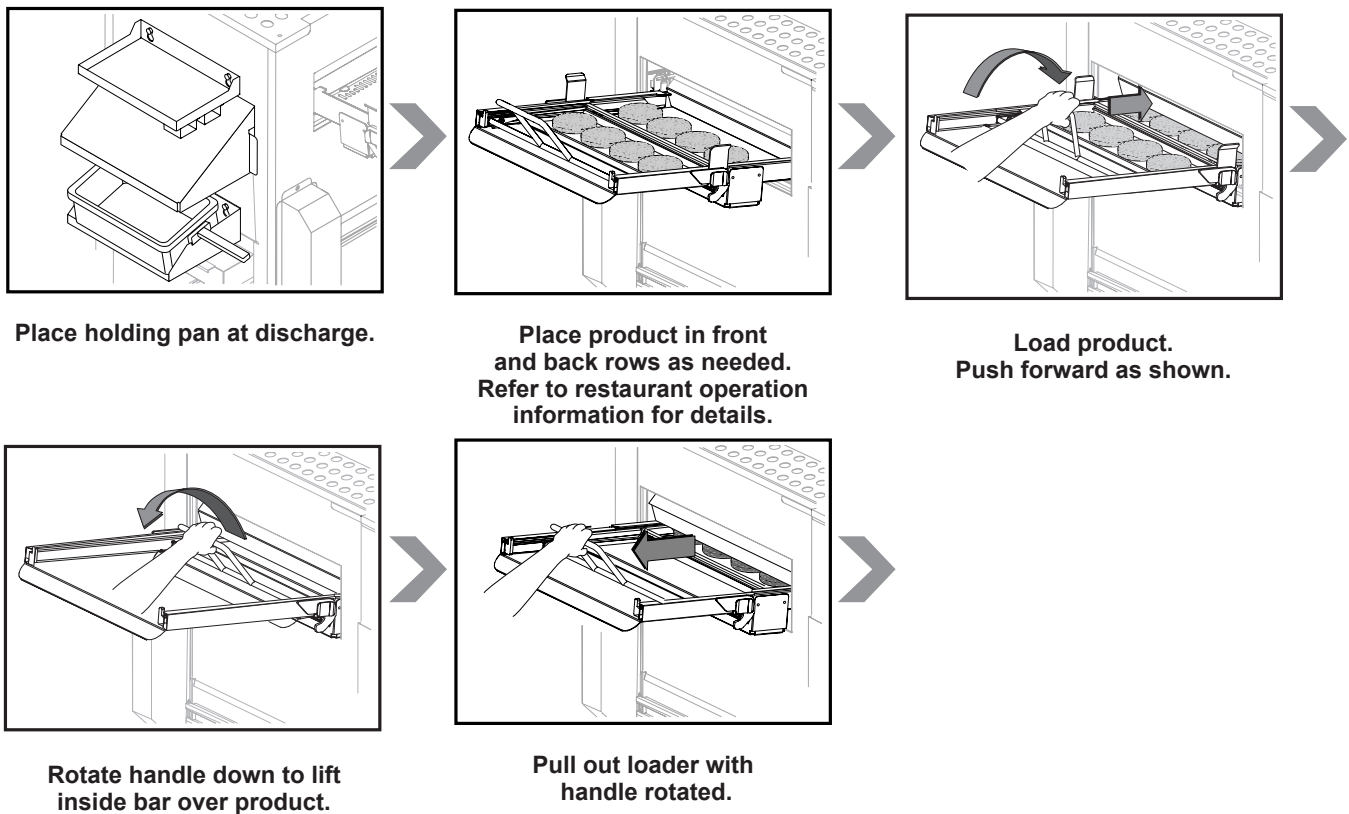

Figure: Ready Screen

Figure: Fine Cooking Adjustment



- When the product has been loaded into the Broiler then touch the corresponding Product Button to begin the cook cycle per each programmed recipe

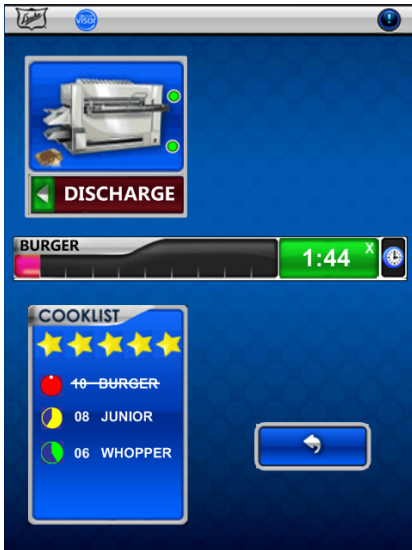





Figure: Active Product Screen

**NOTE: Active cook cycle options:**



**RESELECT**

- Within 15 seconds of beginning the cook cycle, press  to go to the product reselect screen. Then select the correct product button before the timer runs out 

**CANCELLATION**

- Within 15 seconds of beginning the cook cycle, hold  for 3 seconds to cancel the cook and discharge the product.
- After 15 seconds of beginning the cook cycle, hold the recipe timer area  for 3 seconds to cancel the cook and discharge the product.

**FAULT DETAILS**

- The Broiler will discharge the product once the cook cycle is complete and then transition to the Ready Screen if there are no faults.
- If a fault occurs during the cook cycle, the control will request the user to test the product.
- Select  for a good product test or  for a bad product test. The control will transition to the Ready Screen after product condition is selected.
- If , cook a new batch of the product to fulfill the cooklist requirement.

Fault Display Location

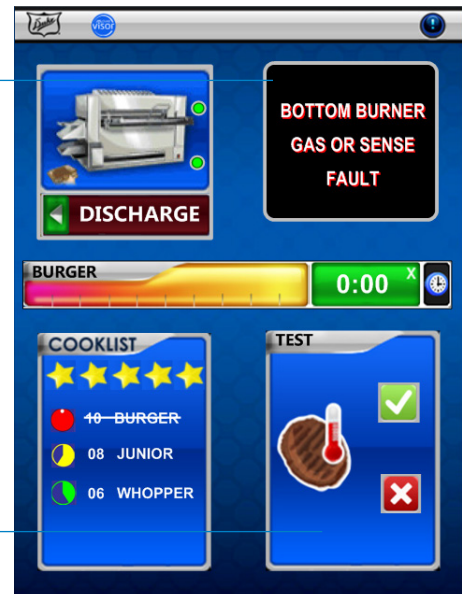

Figure: Fault and Test Overview



**POTENTIAL FAULTS (SEE TROUBLESHOOTING SECTION FOR MORE DETAILS)**

<b>FAULT TYPE</b>	Test Product Top Gas Module Fault	Test Product Top Gas Fault	Test Product Bottom Gas Module Fault	Test Product Bottom Gas Fault	Test Product Temp Sense Fault
	Do Not Use Top Gas Module Fault	Do Not Use Top Gas Fault	Do Not Use Bottom Gas Module Fault	Do Not Use Bottom Gas Fault	Do Not Use Temp Sense Fault

**C. SPECIAL FUNCTION SCREENS (NAVIGATION OVERVIEW)**

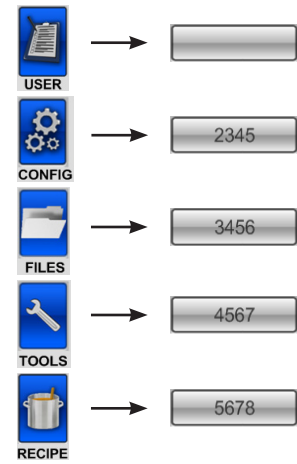

**Figure: Status Bar**

- Access the Special Functions - PIN Code Entry Screen by selecting the info button  on the status bar.
- Enter the PIN Code which corresponds to the desired special function screen.
- Press  once the desired PIN code is entered.



**Figure: Special Functions Screen**



**Figure: PIN Code Entry Options**

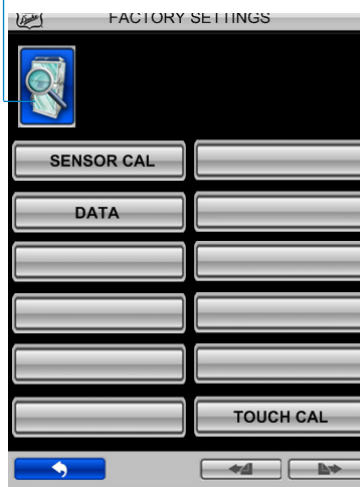
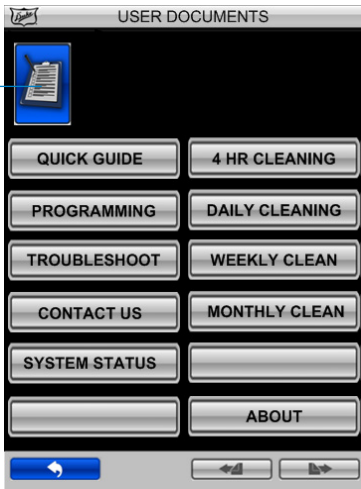





## PROGRAMMING CONTROLS

To access the Special Functions, touch  button on the Main Tool Bar.



**Figure: Special Functions Screen**

1. Touch the  button and then enter pin code 5 6 7 8 and touch the  button when prompted.
2. Touch the button for the recipe you to edit (i.e. ). A recipe can be deleted by selecting the  button and then saved with the  button.

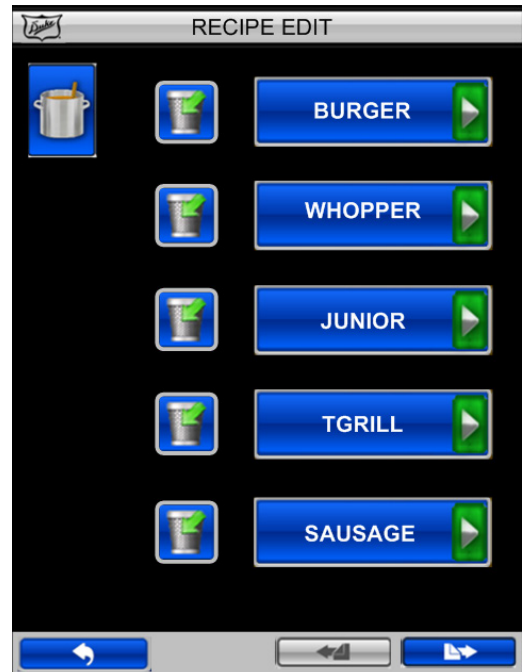

**Figure: Recipe Edit Screen**









3. The recipe edit screen displays the option for 6 stages. Stages that are highlighted blue are used in the total recipe.

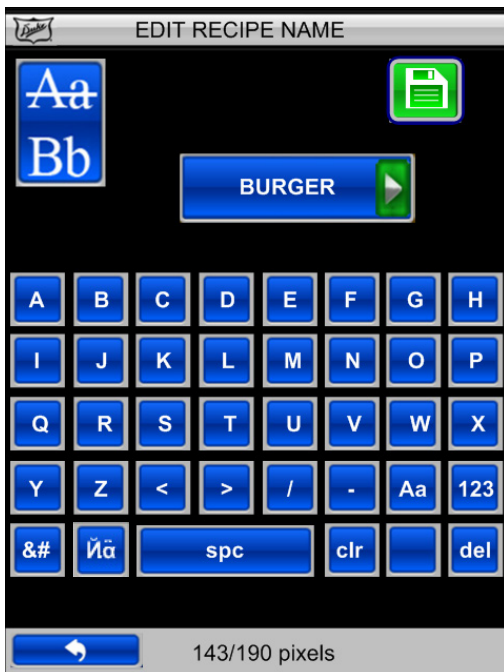

**Figure: Individual Recipe Edit Screen**

4. To edit the recipe name, touch the  button for the Edit Recipe Name screen.





**PRESS:**

-  to toggle the keyboard between the upper/lower case character set.
- ,  and  for the number and symbol keyboards.
-  to space,  to clear all text.
-  to delete/backspace,  to save.



**Figure: Edit Recipe Name Screen**



**CONFIG (CONFIGURATIONS)**

1. Touch the  button and then enter pin code 2 3 4 5 and touch the  button.
2. Touch the button for the setting you want to edit.
  - DATE/TIME – Touching will display DATE/TIME edit screen. Touch the  or  button adjacent to the field you want to change.
  - LANGUAGE – Touching will display a list of included languages. Touch the preferred language button to select.
  - C/F SELECT – Touching will toggle between CENTIGRADE MODE ENABLED and FAHRENHEIT MODE ENABLED.
  - DEFAULT RECIPE – Touching will reload factory defaults.



**Figure: Configuration Screen**

## FILES (FILE MANAGEMENT)

1. Touch the  button and then enter pin code 3 4 5 6 and touch the  button.



2. Select file operation from the list and follow instructions on the display screen.

## PERFORMANCE MAINTENANCE

To access the Special Functions, touch  button on the Main Tool Bar.



Figure: Status Bar







1. Touch the  button, enter pin code 4 5 6 7 and touch the  button.
2. Touch the PM Service button to edit Mini PM and Full PM settings.
3. Touch the  or  button adjacent to the fields to change cook limits.
4. Press the  button and then the  button to reset PM cook limits



Figure: PM Service Screen

## SYSTEM STATUS



To access the Special Functions, touch  button on the Main Tool Bar.



Figure: Status Bar

1. Touch the  button.
2. Touch the System Status button to view Broiler temperature PM status and sensor information.

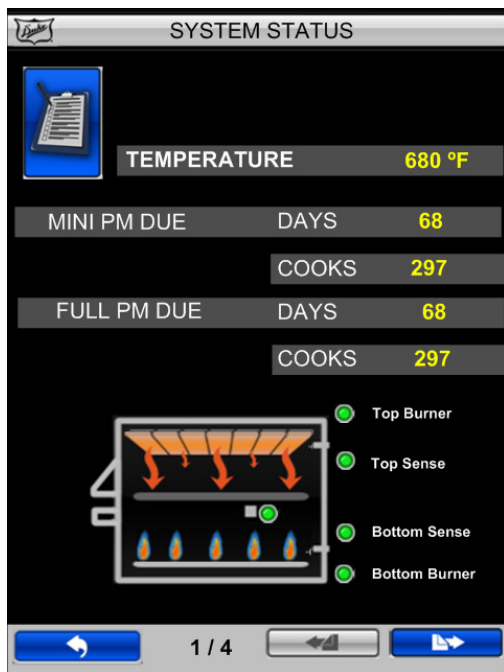

Figure: System Status Screen

## PARAMETER EDIT









To access the Special Functions, touch  button on the Main Tool Bar.



Figure: Status Bar

1. Touch the  button, enter pin code 4 5 6 7 and touch the  button.
2. Touch the Parameters button.
3. Touch the  or  button adjacent to the fields to change.
4. Press  and  cycle each ON/OFF.
5. Press  to save changes.

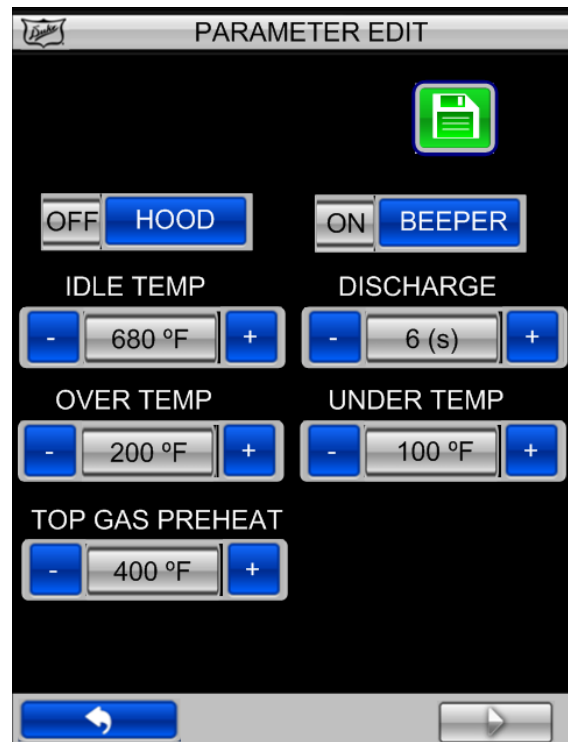

Figure: Parameter Edit Screen

## D. CLEANING

The exterior stainless steel on your broiler can be kept clean with a good non-abrasive stainless steel cleaner, many of which are on the market. Moisten a cloth and wipe down the broiler while it is COLD. Wiping down a broiler while it is hot will cause streaking and otherwise unsatisfactory results. Once the broiler is clean it can be wiped down with light oil. To help make your use of this broiler trouble-free and to maintain the warranty, the following recommendations must be followed:

- A. Do not expose the broiler to prolonged contact with detergents, cleansers, bleaches, etc. Shield the IR burners and flame sensing rods from all cleaning fluids. Do not spray IR burners with any foreign materials. Chemical cleaners, degreasers, bleaches and soap solutions must never be allowed to come into contact with the IR burner metal housings or ceramic burner tiles as they may damage these surfaces and/or cause broiler malfunction and will void the warranty. To prevent damage to the ceramic burner tiles, never allow physical contact with cleaning tools or other objects that may scratch ports in the tile faces. Do not spray flame sensing

rods with any foreign materials. Chemical cleaners, degreasers and soap solutions must never be allowed to come into contact with the flame sensing rods as they may damage these surfaces or cause broiler malfunction and will void the warranty. If required, clean the flame sensing rods only after allowing to cool off to room temperature, and using a light wiping action with a pre-saturated alcohol pad to remove any carbon buildup.

- B. Never leave the chemical compounds, particularly those containing chlorine, on broiler parts overnight. Chlorine will cause pitting and corrosion.
- C. Never use chemicals in a stronger concentration than recommended by the manufacturer.
- D. Use clean water and a soft cloth to wipe cleaning residue from surfaces.
- E. Never use ordinary steel wool or scouring pads on the surfaces: use non-abrasive broiler de-greasers and soft cloths

**Carefully following these recommendations will help this broiler to give satisfactory services to extend its life.**

WHAT'S TO BE CLEANED	BROILER COOL	DISCONNECT POWER
<b>4 HOUR CLEANING</b> (Sanitize in place)		
SANITIZE LOADER & TRAY (CAUTION: HOT SURFACES, WEAR INSULATED GLOVES WHILE CLEANING)		
SANITIZE DISCHARGE CHUTE		
<b>DAILY CLEANING</b> (Remove and Wash/Rinse/Sanitize)		
DISCHARGE PAN (CAUTION: HOT SURFACES, WEAR INSULATED GLOVES WHILE CLEANING)		
DISCHARGE HOOD	X	
DISCHARGE GREASE PANS	X	
MAIN GREASE PANS	X	
DISCHARGE END PANEL	X	
DISCHARGE SCRAPER	X	
LOADER & TRAY (CAUTION: HOT SURFACES, WEAR INSULATED GLOVES WHILE CLEANING)		
DISCHARGE CHUTE	X	
LOADER RAMP	X	
<b>WEEKLY CLEANING</b>		
LOWER TUBE BURNER	X	X
BROILER FLIPPER DOOR	X	X
FLAME ARRESTOR	X	X
CATALYST	X	X
<b>MONTHLY CLEANING</b>		
FLAME SENSOR (UPPER BURNERS)	X	X
FLAME SENSOR (LOWER BURNERS)	X	X
FLAME SENSOR TUBE (UPPER BURNERS)	X	X

### D-1. Four (4) Hour Cleaning

All components that are in contact with food product must be cleaned and sanitized every 4 hours.

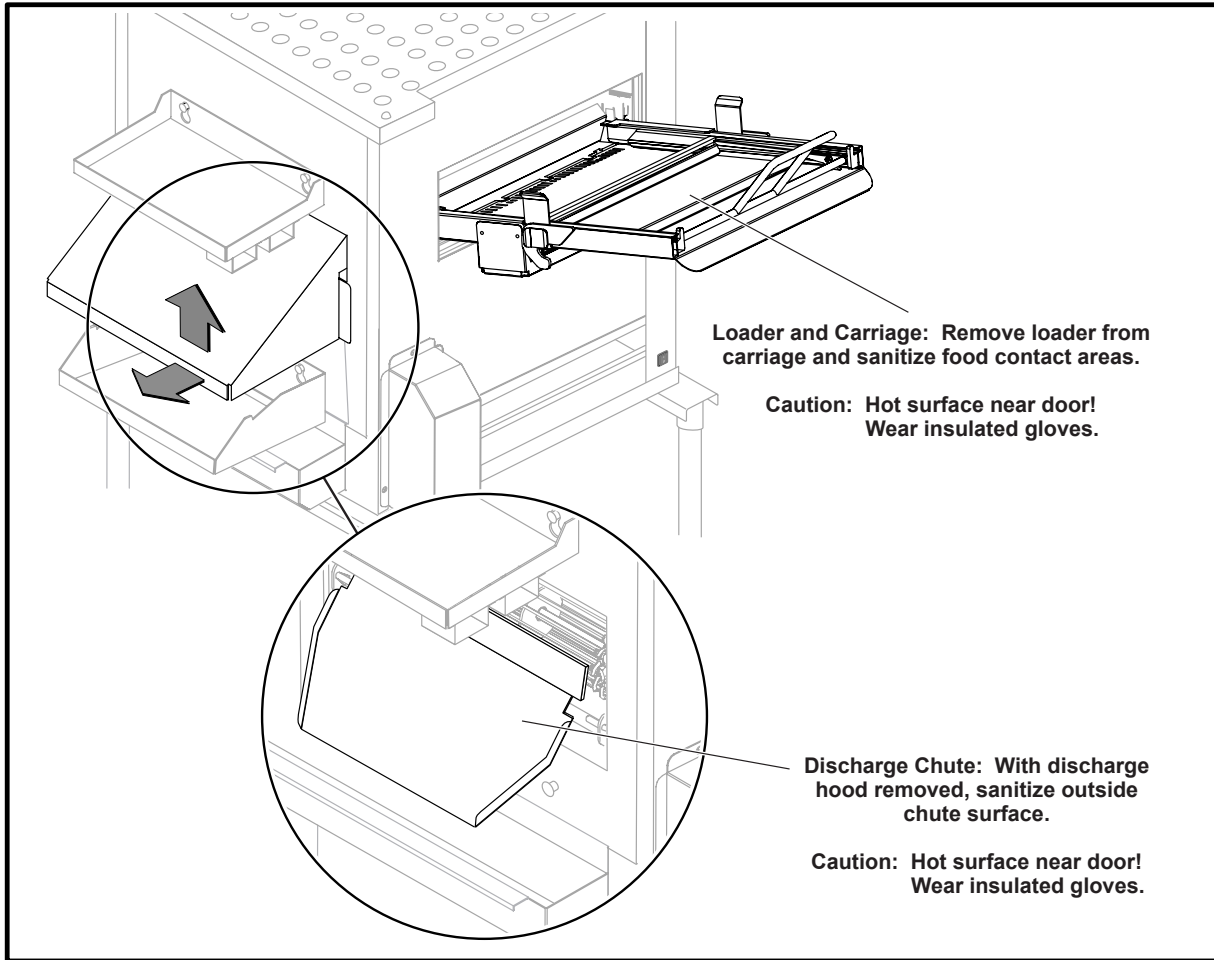

## D-2. Daily Cleaning

Daily cleaning should also include all items listed in the 4 hour cleaning schedule.

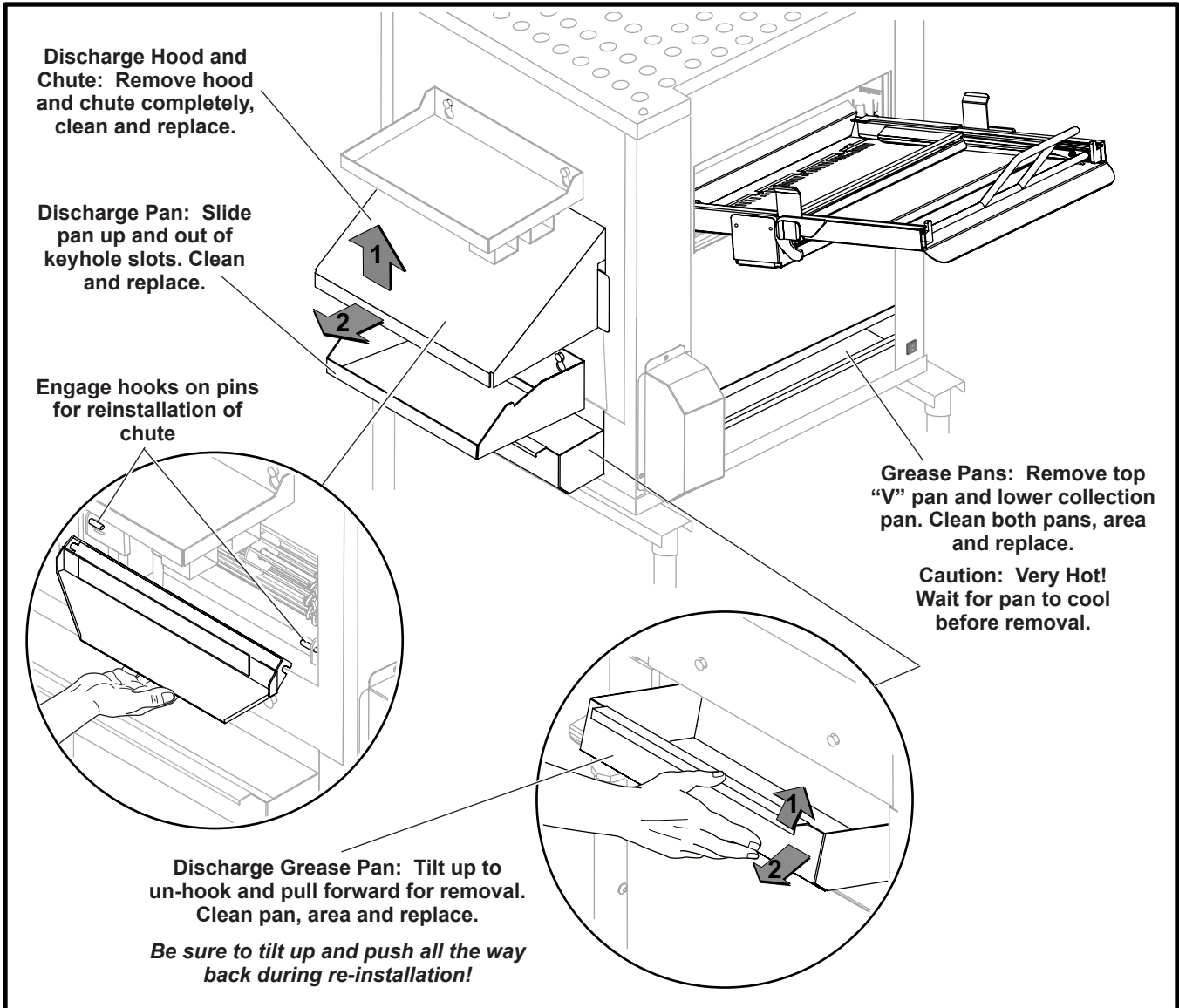

**D-2. Daily Cleaning (cont'd.)**

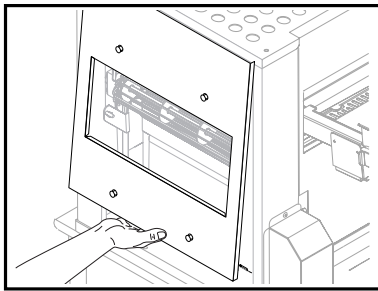

**Discharge End Panel:**  
Remove discharge accessories  
and lift panel up while swinging  
out and down.

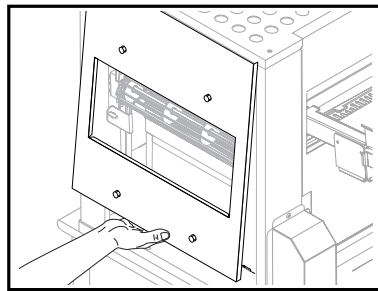

**Discharge Scraper:**  
Lift up and pull forward.

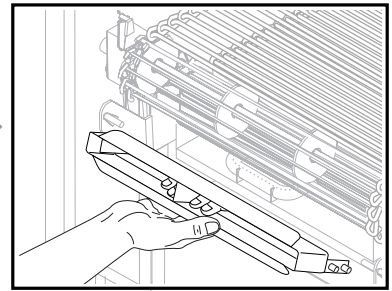

**Discharge Scraper:**  
Pull out removing locating pins  
from slots. Clean scraper and  
area. Replace.

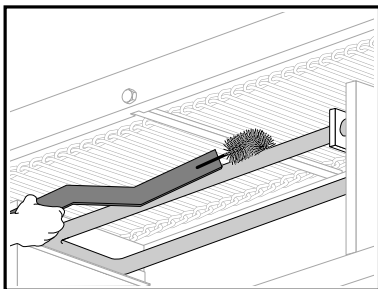

Clean the top of the burner  
with the brush end of the "Tube  
Burner Cleaning Tool".

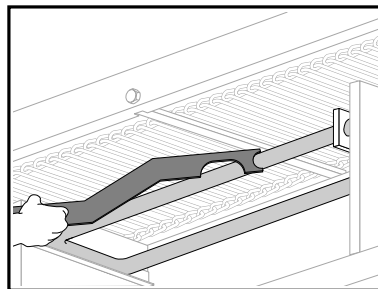

For heavy build-up, use the  
scraper end of the "Tube Burner  
Cleaning Tool".

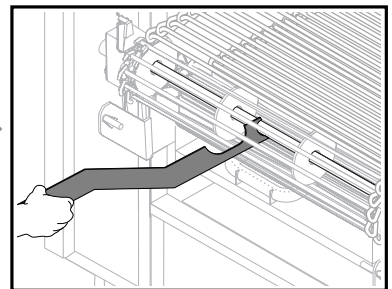

Use the end of the tool to  
clean the discharge shaft of  
the conveyor.

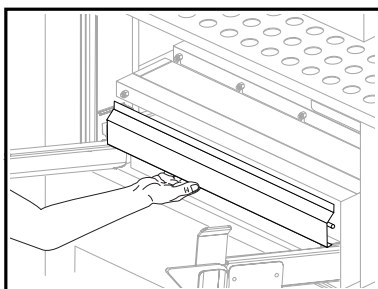

With the broiler cool, lift and  
remove the flipper door.  
Clean and set aside.

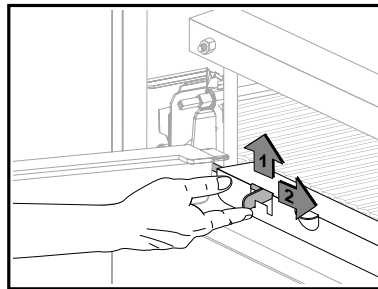

Lift and slide retaining bolt right.

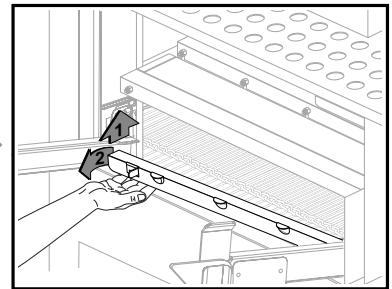

Lift slightly and remove loader  
ramp as shown.

**C-3. Weekly Cleaning**

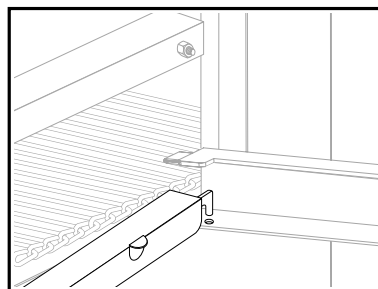

Disengage pin from pivot hole.  
Clean and set aside.

### D-4. Monthly Cleaning

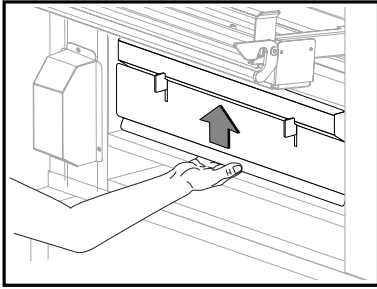

With outer front panel removed, lift up the combustion chamber panel.

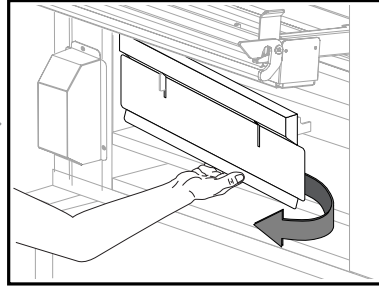

Swing the right side of the panel out as shown. Clean and set aside.

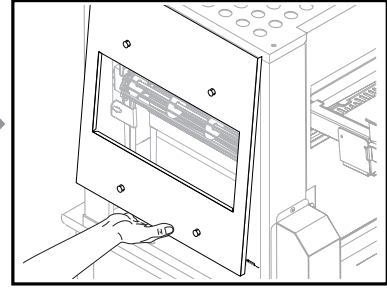

Remove burner shield.

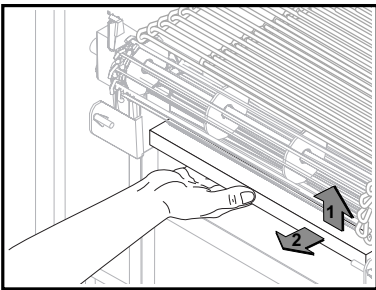

Remove discharge panel and scraper as was performed for daily cleaning.

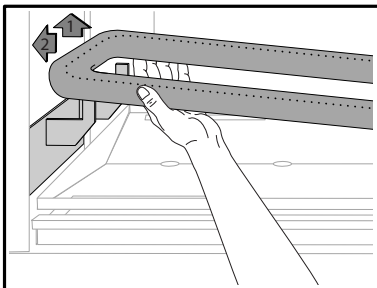
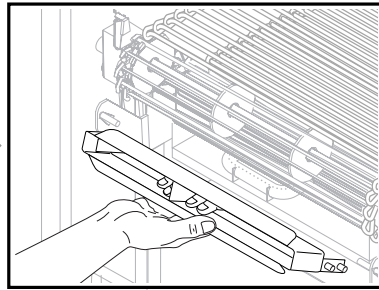

Lift rear of burner out of saddle and continue to hold it.

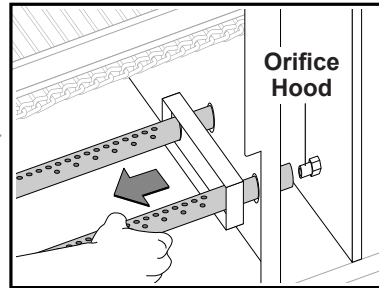

Pull burner off of orifice and through broiler wall. Remove from chamber. Clean, empty any remaining water from the burner and replace. Thoroughly dry out all burner ports!

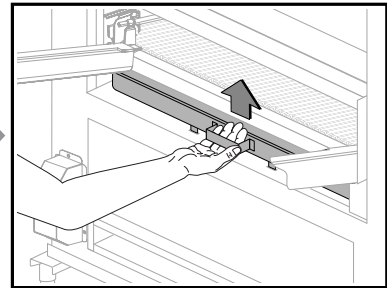

Lift flame arrester up to disengage tabs from slots. Tabs are located under the front of the arrester.

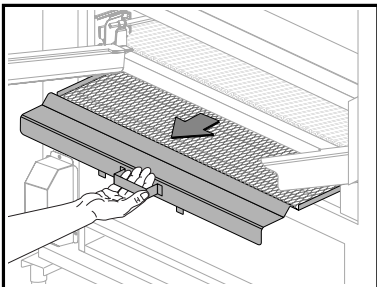

Pull flame arrester out. Clean and reinstall.

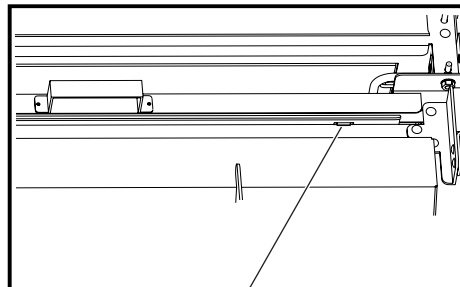

TAB ON THE BOTTOM OF THE FLAME ARRESTOR DROPS INTO SLOT

### D-3. Weekly Cleaning (cont'd)

#### CLEANING CONSIDERATIONS

**⚠ WARNING:** Do not use soap, detergents, degreasers, silicone, sodium salts, bleaches, anti-oxidants or any other commercial cleaning agents to clean the catalyst. Use of these chemicals will damage the catalyst and render it inoperable

**NOTE:** Do not clean catalyst in a dishwasher or ultrasonic cleaner. In no case should any abrasive material or abrasive scrubber be used for cleaning.

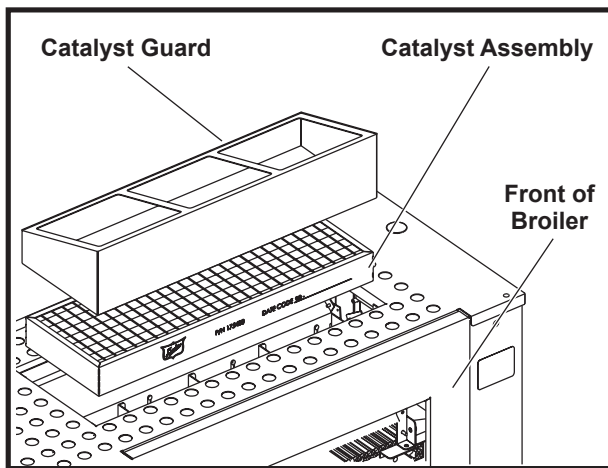

#### SAFETY CONSIDERATIONS

The catalytic converter (catalyst) is normally part of a combustion system, and the general safety practices observed with such systems should be practiced. The following considerations are specific to the catalyst portion.

- A: Remove power: Before removing the catalyst, disconnect power to the broiler and allow to cool to room temperature. Remove the catalyst guard and set aside for re-installation after the catalyst has been cleaned.
- B: Handling catalyst: Care should be taken so that the catalyst is not dropped or damaged in handling. If the unit is going to be handled soon after a cooking cycle, care should be taken to protect one's hands from any hot surfaces by wearing gloves designated for this purpose. There are no moving parts or electrical hookups associated with the catalyst, therefore there should be no danger of a shock hazard when washing the unit. Allow the catalyst to cool to room temperature before starting the cleaning process.
- C: Operation: Understand and follow the system instructions provided with the broiler included in the installation and operations manual. It is very important that you make sure that the ducts above the cooking appliance are clean of any grease, prior to the initial operation of the appliance with the catalytic converter in place.

IF NATURAL GAS IS PART OF THE EXHAUST STREAM, BE SURE THAT THE NATURAL GAS DOES NOT BUILD UP TO AN EXPLOSIVE MIXTURE IN THE EXHAUST SYSTEM.

**D-3. Weekly Cleaning (cont'd)**

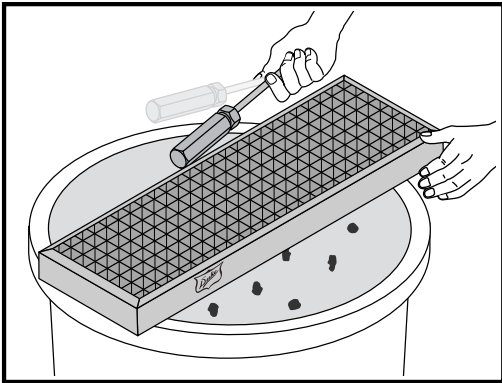

Gently tap frame of the catalyst while holding over a waste bin to dislodge any loose ash/carbon particles.

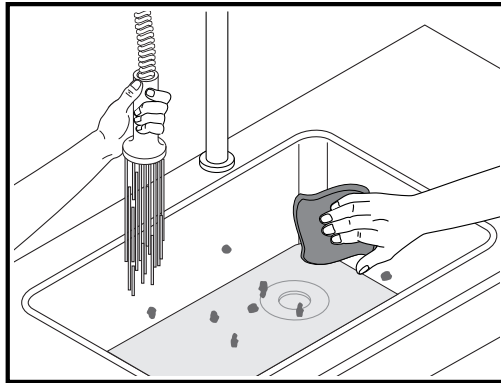

Begin with a clean sink and remove all foreign matter from any wash basin used, before starting the catalyst washing process.

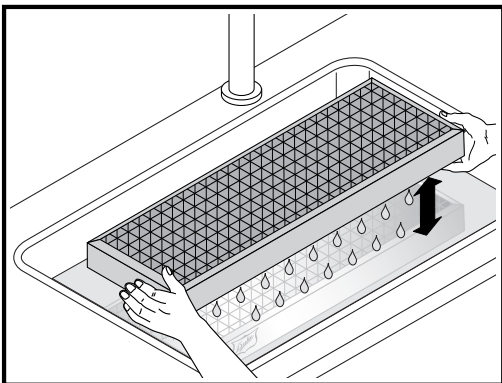

Partially fill wash basin, that is large enough to accommodate the catalyst, with enough clean hot water (100-130°F) to completely cover the catalyst when placed into the basin. Agitate the catalyst up and down in the water a few times and then let it soak for 20 minutes.

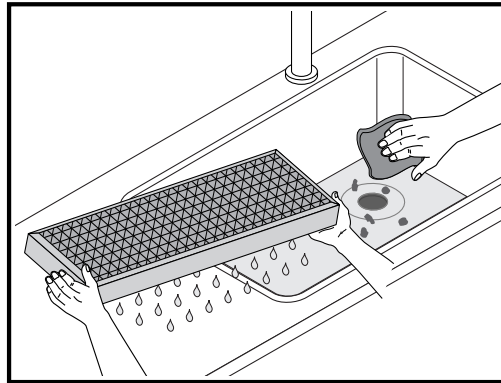

Remove the catalyst and shake out the excess water. Drain and clean the basin thoroughly and then repeat previous step .

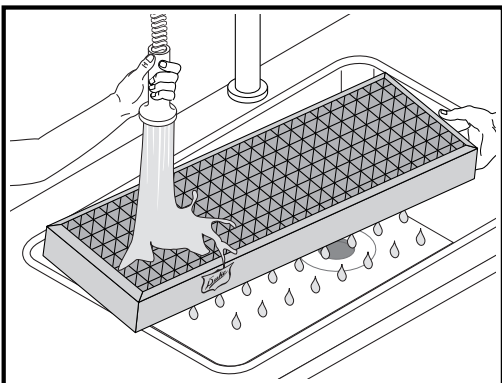

Remove the catalyst and rinse thoroughly with a large volume of hot water. The typical restaurant dishwashing spray nozzle (low pressure, high volume) is perfect for this operation. Work the spray slowly over the entire surface both front and back to assure the removal of any particles caught in the catalyst face or behind the frame. Shake the remaining water from the catalyst and then let it air dry overnight. The catalyst can then be reinstalled in the broiler. Ensure that the catalyst guard is re-installed over the catalyst prior to turning on the broiler.

### D-4. Monthly Cleaning

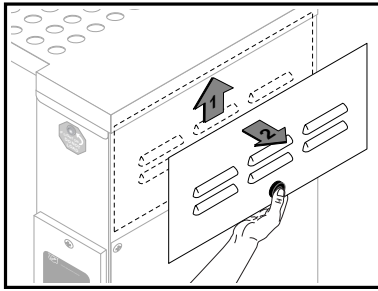

Remove top panel by lifting up and out.

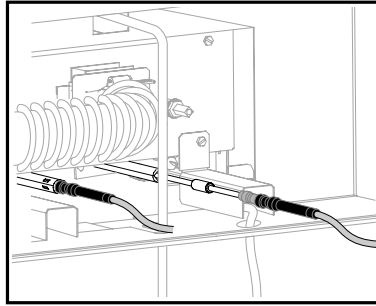

Locate the flame sensors for the upper burners.

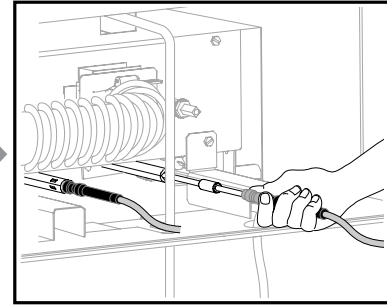

Use caution and safely remove the sensor by holding onto the black boot at the base of the sensor.

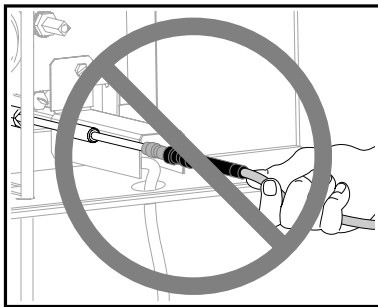

**DO NOT REMOVE BY PULLING ON THE BRAIDED WIRE.**

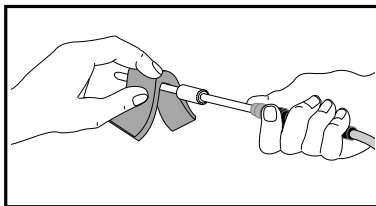

Using an alcohol swab, clean the entire metal portion of the sensor rod to remove any buildup. Clean the white ceramic insulator using the alcohol swab until all residue has been removed.

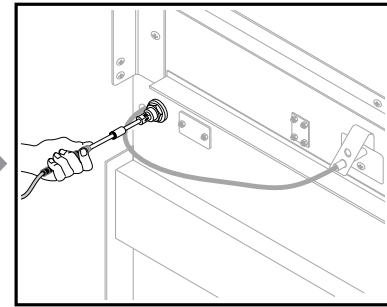

Remove the back panel of the broiler and carefully remove the sensor for the lower burner. Follow the same procedures as those for the upper burners.

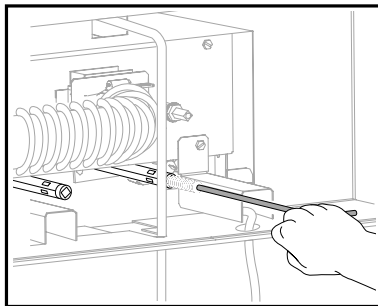

After the sensor is removed, use the T-handled cleaning tool by inserting it completely into the sensor tubes and remove. Repeat the process at least five (5) times to remove any residue inside the tube.

Once the cleaning procedures are complete, replace the sensors and panels. Wait at least 30 minutes before starting the broiler.

## IV. SERVICE AND REPAIR

SYMPTOM	CAUSE	REMEDY
Control display does not light up	No power	Ensure broiler is plugged into a proper voltage/Hz receptacle (per name plate rating) and receptacle as power. Check dedicated circuit breaker.
Raw or undercooked product with no controller error messages displayed.	Product not loaded properly.  Product button was depressed prior to loading product.  Wrong product button was depressed.  Lower burner not lighting properly. (Observe bottom burner through slits in lower grease tray)  Infrared burners not lighting properly. (Observe Infrared through discharge end of broiler. Note: Burners should remain lit in idle mode)	Review loading technique.  Ensure product button is depressed immediately after product is loaded into broiler.  Ensure proper product button is being depressed.  If broiler is hot, attempt to clean burner in place with broiler cleaning tool. If broiler is cold or allowed to cool down, remove lower burner by removing access panels, clean, and reinstall. Remove lower flame sensor and clean with a soft cloth and isopropyl alcohol.  Remove upper control compartment panel and clean two upper flame sensors with a soft cloth and isopropyl alcohol. Clean flame sensor tube with flame sensing tube cleaning brush.
Conveyor belt will not move to discharge product.	Conveyor belt is being obstructed	Observe for obstructions by manually rotating conveyor belt from discharge end of broiler using broiler cleaning tool. Ensure discharge scraper is properly in place. Ensure docking plate is properly in place. Ensure flame arrestor is properly in place.
Loader is not able to be pushed completely into cooking chamber.	Docking plate is not properly in place.	Ensure docking plate and locking tab are correctly in place.
Product is getting stuck or mangled upon loading	Docking plate is not properly in place  Flame arrestor is not properly in place	Ensure docking plate and locking tab are correctly in place.  Ensure flame arrestor is correctly in place and tabs are slotted correctly.
Test Product-Top Gas Module Fault  Do Not Use-Top Gas Module Fault	Loss of connection to module, module failure, IR blower failure	Pull out flame sensors and clean any debris, then push in flame sensors. If burner faults continue perform Monthly Cleaning Procedure, and recheck Top Burner. Check Top Burner for an even orange glow over both IR burner tiles. If burner is not operating evenly call for Service.
Test Product-Top Gas Fault  Do Not Use-Top Gas Fault	Flame sensor or Bottom Burner error	Pull out flame sensors and clean any debris, then push in flame sensors. If burner faults continue perform Monthly Cleaning Procedure, and recheck Top Burner. Check Top Burner for an even blue flame around the U-burner. If burner is not operating evenly call for Service.
Test Product-Bottom Gas Module Fault  Do Not Use-Bottom Gas Module Fault	Loss of connection to module, module failure	Pull out flame sensors and clean any debris, then push in flame sensors. If burner faults continue perform Monthly Cleaning Procedure, and recheck Top Burner. Check Top Burner for an even orange glow over both IR burner tiles. If burner is not operating evenly call for Service.
Test Product-Bottom Gas Fault  Do Not Use Bottom Gas Fault	Flame sensor or Bottom Burner error	Pull out flame sensors and clean any debris, then push in flame sensors. If burner faults continue perform Monthly Cleaning Procedure, and recheck Top Burner. Check Top Burner for an even blue flame around the U-burner. If burner is not operating evenly call for Service.
Test Product-Temp Sense Fault  Do Not Use-Temp Sense Fault	Temp Sensor error	Pull out Temp Sense Probe. Clean any debris and puch in probe. If fault continues, call for service.

**⚠ WARNING:** Disconnect the power supply to the appliance before servicing.

**⚠ WARNING:** Units provided with casters have a restraint to limit the movement of the broiler. If this restraint is disconnected during servicing it must be reconnected after the appliance has been returned to its original installed position.

**NOTE:** Proper clearances must be maintained during servicing.

Maintenance is to be performed by qualified service personnel only. Service by other than qualified personnel may result in damage to the broiler and/or injury to the operator.

Qualified service personnel are those individuals,

firms, companies or corporations which either in person or through an agent are engaged in and responsible for repair or servicing of commercial food preparation equipment, who are experienced in such work, familiar with all precautions required, and have complied with all requirements of state and local authorities having jurisdiction.

If you should require assistance in the selection of a qualified service agency, please contact Duke Manufacturing Co.'s Service Department at 800-735-3853.

## V. REPLACEMENT PARTS LIST

ITEM	DESCRIPTION	P/N
1	SWITCH, LIGHTED, DPST	175503
2	BURNER, INFRARED	175780
3	BURNER, TUBE, J STYLE (FOR USE IN US & CANADA)	175505
	KIT, BURNER, ADJUSTABLE (FOR USE OUTSIDE US & CANADA)	175950
4	MOTOR-CONVEYOR	175867
5	SPROCKET, B21X3/8 BORE (MOTOR)	175517
6	SHAFT, DISCHARGE SIDE	175037
7	SHAFT, RIGHT SIDE	175038
8	CAPACITOR, MOTOR-CONVEYOR	175507
9	MODULE, IGNITION (LOWER BURNER - NATURAL GAS)	175877
	MODULE, IGNITION (LOWER BURNER - PROPANE)	175872
10	MODULE, IGNITION (UPPER BURNERS)	175869
11	TRANSFORMER, VPS24-3300 TSC	176706
12	PROBE, TEMP., C-CHAMBER	175977
13	LED, INDICATOR LIGHT, RED, 12V TSC	176693
14	CHAIN DRIVE	175551
15	TOUCH SCREEN, CONTROL, W-SOFTWARE	ELC0017-4
16	GASKET, BLOWER INLET	175511
17	BLOWER, 120V 60HZ W/CENTRIFUGAL SWITCH	176185
18	HOSE, BLOWER	175189
19	ORIFICE HOLDER, IR	175542
20	VALVE, LP - GAS, COMBO 24VAC (PROPANE ONLY)	175766
	VALVE, NAT -GAS COMBO 24VAC (NATURAL GAS ONLY)	175531
21	ORIFICE, LOWER BURNER #31/3.05MM, (NAT. GAS ONLY)	175823
	ORIFICE, LOWER BURNER #49 (PROPANE ONLY)	175737
22	ORIFICE, IR FRONT #40 (NATURAL GAS ONLY)	175735
	ORIFICE, IR FRONT #52 (PROPANE GAS ONLY)	175767
23	ORIFICE, IR REAR #36 (NATURAL GAS ONLY)	175736
	ORIFICE, IR REAR #51 (PROPANE GAS ONLY)	175768
24	ORIFICE HOLDER 3/8 COMP. STRGHT X BULKHEAD	176368
25	TUBING-TEE TO VALVE, KIT	175477
26	TUBING-TEE TO IR, KIT	175476
27	TUBING-LOWER BURNER TO VALVE, KIT	175478
28	SENSOR-LOWER BURNER	175534
29	SENSOR-IR BURNER	175535
30	IGNITER	175536
31	IGNITION SUPPRESSION CABLE-IR	175537
32	IGNITION SUPPRESSION CABLE-LOWER	175538

## V. REPLACEMENT PARTS LIST (CONT'D)

ITEM	DESCRIPTION	P/N
33	CHAIN, COOK	175674
34	BUSHING BLOCK, CONVEYOR	175525
35	LOADER TRAY	175430
36	LOADER MOUNTING BRACKET	175438
37	LOADER	175444
38	LOADER RAMP	175741
39	DOOR	175429
40	FLAME ARRESTOR	175293
41	BURNER SHIELD	175200
42	DISCHARGE CHUTE	175340
43	DISCHARGE HOOD	175778
44	PRODUCT PAN SHELF	175363
45	DISCHARGE PAN	175358
46	MAIN GREASE PAN	175329
47	"V" GREASE PAN	175325
48	SIDE, GREASE PAN	175357
49	PIVOT ASH SCRAPER	175150
50	REAR PANEL	175305
51	FRONT PANEL	175300
52	PANEL, UPPER, LIFT OFF	175392
53	PANEL, ACCESS ELECTRICAL	175383
54	PANEL, ACCESS DISCHARGE	175250
55	IMPEDANCE PAN (IF NO OPTIONAL CATALYST)	175226
56	CATALYST (OPTIONAL)	175480
57	CATALYST, GUARD	175482
58	TUBE BURNER CLEANING TOOL	175485
59	FLAME ROD TUBE CLEANER	175701
60	BRUSH, FLAME ROD TUBE CLEANER	175705
61	SANITATION PAIL	175842
62	IO4 BOARD, BROILER TSC	176669
63	RPB BOARD, BROILER TSC	176670
64	ACM, PCB - MAIN TSC	166112
65	BUZZER, ULTRA LOUD TSC	512766
66	CONNECTOR, USB PANEL MOUNT TSC	120007
67	JUMPER, USB TO USB TSC	166141
68	GASKET, INNER COVER, BROILER TSC	176718
69	GASKET, OUTER COVER, BROILER TSC	176719
70	GASKET, ACM MOUNTING, BROILER TSC	176720

## VI. WIRING SCHEMATIC

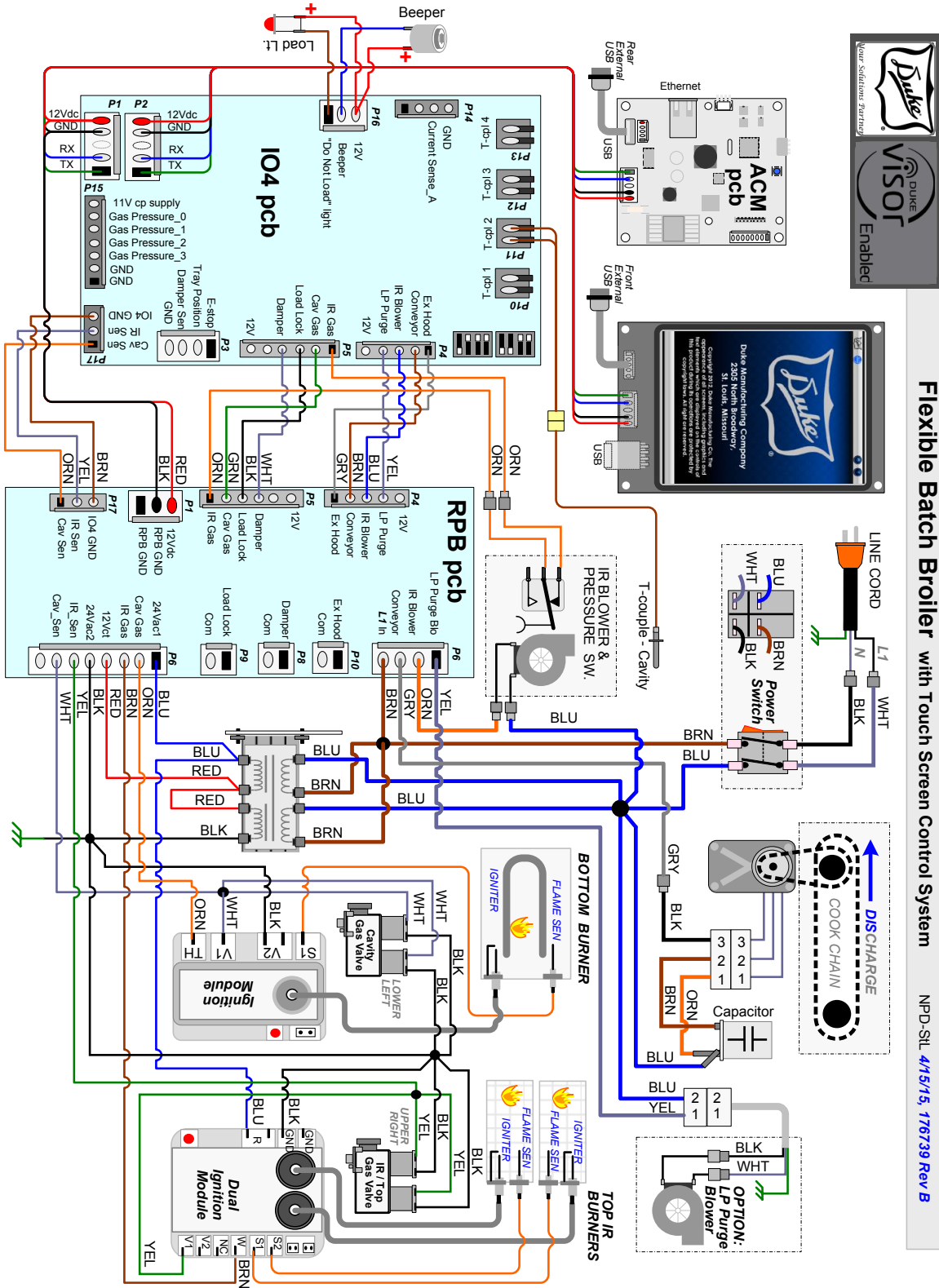

Flexible Batch Broiler with Touch Screen Control System

NPD-SIL 4/15/15, 176739 Rev B

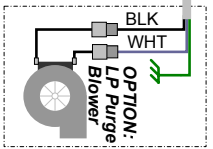
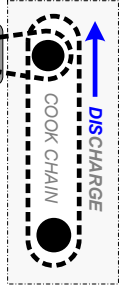
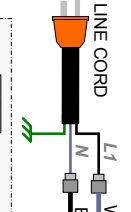
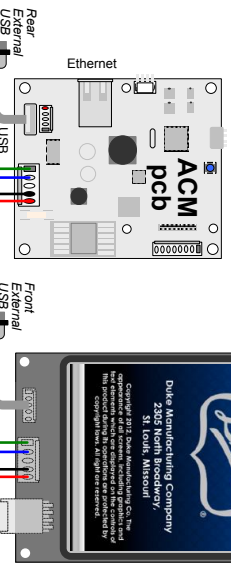



*Your Solutions Partner*

## **Duke Manufacturing Co.**

2305 N. Broadway  
St. Louis, MO 63102  
Phone: 314-231-1130  
Toll Free: 1-800-735-3853  
Fax: 314-231-5074

[www.dukemfg.com](http://www.dukemfg.com)