

# Operations Manual

Edge Plus - 25"x40" Tortilla Warmer Grill

Model #: TWD2540



**PROLUXE**

[WWW.PROLUXE.COM](http://WWW.PROLUXE.COM)

Version: 51719

## Safety Summary



### WARNING

In case of power cord damage, do not attempt to repair or replace the power card. Contact the manufacturer or the local distributor.



### WARNING

Avoid touching hot surfaces while operating the machine.



### CAUTION

During normal operation, the base of the machine must be installed or placed above the wall socket.



### CAUTION

When servicing or cleaning the machine, make sure that the power cord is removed from the wall socket.

## Controller Operation

### *Temperature Control*

1. Press the MODE button until temperature is displayed.
2. Push and Hold SET button and simultaneously push UP (▲) or DOWN (▼) arrow buttons to the desired temperature setting

## Control Board Operations

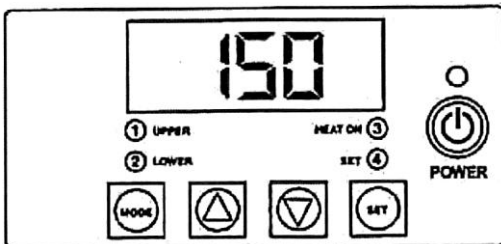

## Solid Stage Controller

1. Temperature-Temperature may be set from 100°F to 430°F. If you would like to change this setting, simply follow the *Controller Operation* directions.

## **CLEANING**

Use only cleaners which are safe for **ALUMINUM**. **DO NOT** use caustic cleaners, ice or cold water to clean the grill. Turn grill down or OFF during idle periods to prevent carbon buildup.

1. Turn power off and unplug, allow grill to cool.
2. Remove particles by using a spatula with rounded corners.
3. Wipe down all surfaces using a warm damp cloth and mild detergent.

## **CARBON CLEANING**

When carbon buildup occurs, use a carbon removal agent which is safe for aluminum, follow the instructions provided with the product. When this process is complete, you must re-season your grill.

## **INITIAL START UP**

Before using the unit for the first time, wipe down the exterior and platen area with a damp cloth.

Heat for approximately 30 minutes. The warmer may emit a small amount of smoke as the cooking surface reaches its operating temperature. This is normal, as the smoke is caused by oils associated with the manufacturing process and will stop when the burn off is complete. Brush off any debris from the warming surface.

## **SEASONING THE TORTILLA GRILL HEATING SURFACE**

### **FIRST TIME SEASONING**

Follow your company/corporate guidelines for seasoning cooking surfaces or perform the following:

1. Bring the grill to 300°F (148°C) and leave it on while performing the next three steps.
2. Brush the cooking surfaces with a release agent. If using an aerosol agent, first apply into a cup and then brush onto cooking surface.
3. Let sit for 20 minutes.
4. Wipe the cooking surface clean, using a warm damp cloth.

### **\*Warning\***

**DO NOT SUBMERGE IN WATER OR ALLOW WATER TO SPILL INTO THE ELECTRICAL HOUSING. AS THIS WILL VOID WARRANTY AND DAMAGE THE UNIT.**

**\*Caution** - To reduce the risk of fire, the appliance is to be installed in non-combustible surroundings only, with no combustible material within 18 inches of the sides, front, or rear of the appliance or within 40 inches above the appliance. The appliance is to be mounted on floors of noncombustible construction with noncombustible flooring and surface finish and with no combustible material against the underside, or on noncombustible slabs or arches have no combustible material against the underside. Such construction shall in all cases extend not less than 12 inches beyond the equipment on all sides.

## TW2023&TW2540 Recommended Cleaning Procedures

**DO NOT use ice or cold water to cool unit down.**

**This causes the platens to warp.**

TOOLS REQUIRED: 1. Spatula w/ rounded corners 2. Damp Washcloth 3. Griddle cleaner



1. Turn off grill and allow to cool down.

2. Apply small amount of cleaner to grill surface

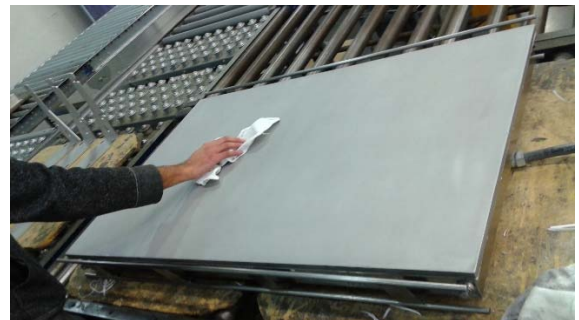

3. Use spatula w/ round edges to remove particles

4. Use warm damp cloth to wipe grill surface.

# PROLUXE

## TWD2540E

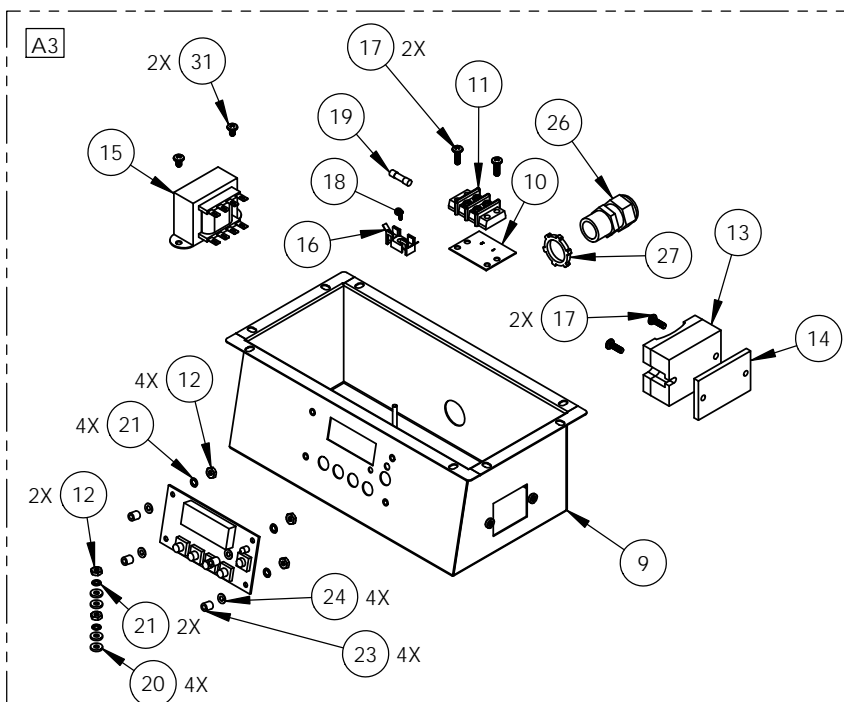
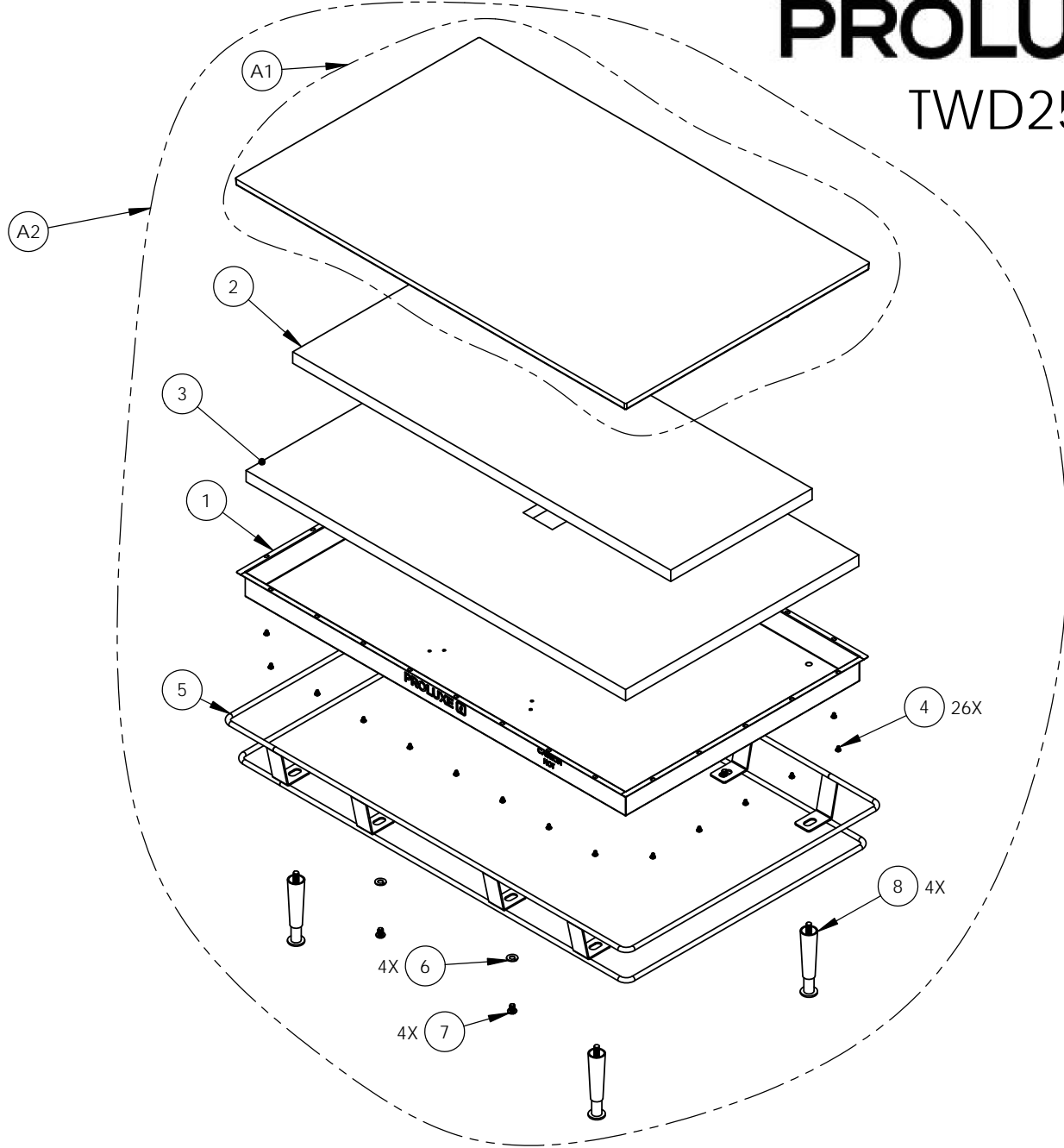

## PARTS LIST FOR MODEL TWD2540E

| ITEM NO. | DESCRIPTION  | PART NUMBER | QTY. |
|----------|--|-------------|------|
| 1        | SHROUD, TWD2540E                                     | TP23481     | 1    |
| 2        | INSULATION, FIBERGLASS 15 X 40                       | 110108815   | 1    |
| 3        | INSULATION, FIBERGLASS 10 X 40                       | 110108810   | 1    |
| 4        | SCREW, PHILLIPS PAN HEAD 10-24 X 1/4 STAINLESS STEEL | SP102414S   | 26   |
| 5        | BURN GUARD ASSEMBLY                                  | TP23490     | 1    |
| 6        | WASHER SPLIT LOCK 3/8                                | WL38        | 4    |
| 7        | SCREW, BUTTON HEAD 3/8-16 X 1/2 STAINLESS STEEL      | SB381612S   | 4    |
| 8        | LEG, APPLIANCE, 4"                                   | AE601653    | 4    |
| 9        | ELECTRICAL HOUSING                                   | TP234052    | 1    |
| 10       | MARKER STRIP #4, DOUBLE                              | MS6012      | 1    |
| 11       | TERMINAL BLOCK #2, DOUBLE                            | 6012        | 1    |
| 12       | NUT, HEX 6-32  | NH632       | 6    |
| 13       | RELAY  | MPR90217    | 1    |
| 14       | HEAT SINK, ALUMINUM                                  | 11057322    | 1    |
| 15       | TRANSFORMER  | 11096975    | 1    |
| 16       | FUSE HOLDER  | MPPF708     | 1    |
| 17       | SCREW, PAN HEAD PHILLIPS 8-32 X 1/2                  | SP83212     | 4    |
| 18       | SCREW, PAN HEAD PHILLIPS 2-56 X 1/4                  | SP25614     | 1    |
| 19       | FUSE BUSS 1 AMP                                      | MPPF701R    | 1    |
| 20       | WASHER SAE 6   | WSAE6       | 4    |
| 21       | WASHER, INTERNAL TOOTH LOCK #6                       | WLIT6       | 6    |
| 22       | CONTROLLER   | MPC90214    | 1    |
| 23       | NYLON SPACER   | 11090109    | 4    |
| 24       | WASHER, .311 OD X .150 ID X .20 THK                  | 311150019   | 4    |
| 25       | SCREW, PAN HEAD PHILLIPS 8-32 X 3/8 SS               | SP83238S    | 8    |
| 26       | STRAIN RELIEF  | 3231        | 1    |
| 27       | NUT, CONDUIT 1/2"                                    | NC12        | 1    |
| 28       | POWER CORD   | 1101009176  | 1    |
| 29       | GASKET   | TP234140    | 1    |
| 30       | OVERLAY  | ODP1300B    | 1    |
| 31       | SCREW, PAN HEAD PHILLIPS 8-32 X 1/4 SS               | SP83214S    | 2    |
| A1       | HEATED PLATEN ASSEMBLY                               | TP23432K    | 1    |
| A2       | HEATED PLATEN AND SHROUD ASSEMBLY                    | TP23432AK   | 1    |
| A3       | ELECTRICAL HOUSING ASSEMBLY                          | TP234052K   | 1    |



**PLEASE READ CAREFULLY BEFORE ATTEMPTING TO USE THIS APPLIANCE.**

## **LIMITED MACHINE WARRANTY**

### **WHAT IS COVERED**

Proluxe warrants the TW Series, from manufacturing defects in workmanship and material sold within the domestic United States.

### **HOW LONG DOES THE COVERAGE LAST**

One year warranty for parts and labor.

### **WHAT WE WILL DO**

We will repair or replace the defective TW Series on normal warranty one year parts and labor. The heating elements on the upper and lower platen only; will be replaced by next day air service; under the normal one year warranty. Such repair or replacement will be at the expense of Proluxe on under the normal one year warranty.

### **HOW TO GET SERVICE**

Contact our Factory to obtain warranty service. Proluxe must issue a return authorization number, and call tag, or find the name and location of a Factory Authorized Service Center nearest you. When calling for service, please furnish the model number, serial number, and a description of the problem.

### **WHAT THIS WARRANTY DOES NOT COVER**

THE WARRANTIES PROVIDED BY PROLUXE DO NOT APPLY IN THE FOLLOWING INSTANCES:

- Damage due to misuse, abuse, alteration, or accident.
- Improper or unauthorized repairs.
- Submerged in water.
- Dropped.
- Damage in shipment.
- Equipment exported to foreign countries.

# PROLUXE

## Warranty & Return Policy

**Proluxe** warrants all products manufactured by it against defects in workmanship or materials from the date of purchase for a period of (1) year on parts and labor. **This warranty applies to only equipment purchased and used in the United States.** Warranty period shall begin when equipment ships. Warranty travel shall only be covered for 60 miles. Limited lifetime warranty on heating elements.

**ALL WARRANTY SERVICE CALLS MUST BE APPROVED BY PROLUXE. IF THIS PROCEDURE IS NOT FOLLOWED, WARRANTY SERVICE WILL NOT BE COVERED. WARRANTY SERVICE WILL BE PAID ON STRAIGHT TIME, OVERTIME WILL NOT BE COVERED.**

### **Exclusions:**

- WOOD / GAS FIRED OVENS:** PROLUXE warranty applies to the main body of the oven being steel / refractory and insulation shall be free from defects in materials and workmanship for a period of four years from the date of purchase. The gas equipment shall be free from defects in materials and workmanship for a period of one (1) year from the date of purchase. Lifetime warranty against cracks on oven floor.
- Air compressors are excluded from this warranty,** but PROLUXE may act as a warranty expeditor in certain instances regarding these compressors. The air compressor manufacturer provides a limited warranty and a copy of this warranty is furnished with all compressors sold by PROLUXE. For prompt handling of compressor warranty claims the instructions of the compressor manufacturer must be adhered to.
- Equipment built to special order as well as accessories** cannot be canceled and are not returnable unless defective within the terms of this warranty.
- In no event shall PROLUXE be liable for consequential damages arising out of the failure of any of its products if operated improperly, altered or caused by normal wear or damage by operator abuse.**
- BC2325 pedestal warranty disclaimer:** Pedestals shall only be covered under warranty if they have been cleaned using the factory approved cleaning method. Cracked or damaged pedestals must be inspected by the factory before warranty is authorized.
- Limited lifetime warranty on heating elements:** If replacement is needed, Proluxe will send the new part at no charge but labor will not be covered unless the unit is still under the 1 year manufacture warranty.

### **Returned Merchandise Policy:**

Should it become necessary to return any of the company's products, the following instructions must be adhered to: First, contact our customer service department for approval and a return authorization number. *Please have the serial number of your item available at that time.* All merchandise must be shipped *freight prepaid* by customer or service agency. Subject to the inspection of the product by the company, a restocking charge of 20% of the Net purchased price paid to PROLUXE will be assessed. Merchandise may not be returned for credit without *prior written approval* of PROLUXE. Collect shipments *will not* be accepted. No returns after 60 days of original shipment date on machines. Purchased parts may not be returned after 30 days.

If upon inspection by PROLUXE or its authorized agent it is determined the equipment has not been used in an appropriate manner, has been modified, or has not been properly maintained, or has been subject to misuse, misapplication, neglect, abuse, accident, unauthorized modification, damage during transit, delivery, fire, flood, act or war, riot or act of God, then this warranty shall be deemed null and void.

### **Terms & Conditions:**

- Prices indicated in the PRICE LIST are suggested retail prices and are shown in U.S. DOLLARS.
- Terms of Payment: NET 30 days.
- NEW ACCOUNTS:** Satisfactory credit information must be provided before open account status can be extended. Unless agreed otherwise, all shipments will be made C.O.D., CASH IN ADVANCE.
- PRICING:** Prices, specifications, model numbers, capacities and accessories are subject to change without notice.
- FREIGHT / ROUTING:** Method of shipment will be determined by PROLUXE unless otherwise advised by PURCHASER.
- DAMAGED CLAIMS:** All merchandise shipped at purchaser's risk. Inspection must be made by purchaser at time goods are received. If goods are damaged, the PURCHASER shall request that the agent of the transportation company make a written notation on the proper shipping documents immediately and then file a claim for damage. **GOODS DAMAGED IN SHIPMENT ARE NOT RETURNABLE.**
- RETURNS:** Machines may not be returned after 60 days. Purchased parts may not be returned after 30 days. A restocking fee of 20% will be assessed on non-warranty returns.
- TAXES:** Prices indicated herein DO NOT include State, Federal, Local or foreign taxes or duties, nor do they include fees, permits, insurance or other levies, all of which are the responsibility of the purchaser.
- All orders are subject to acceptance by PROLUXE.
- Possession of this price list shall not be considered an offer to sell.